

TY - 250 P

Description:

This transformer operates in the 20 Hz to 20,000 Hz range, making it suitable for a broad application spectrum in the audio industry. This device is used in line matching, telephone coupling, pulse trigger, driver, interstage, and isolation input and output applications.

Operating Temperature Range: -40° C to 105° C

Electrical Specifications at 25° C:

- | | |
|-----------------------------|-----------------------------------|
| 1. Primary Impedance: | 1000Ω CT * |
| 2. Secondary Impedance: | 1000Ω CT / 250Ω * |
| 3. Output: | 20mW * |
| 4. Primary DC Unbalance: | 4 mA |
| 5. Frequency Response: | ± 1db from 20 to 20,000 Hz |
| 8. Insertion Loss @ 1K Hz: | < 2.8db |
| 11. DCR: Primary (2-4) | 172Ω Nominal |
| Secondary (5-8, w/6-7 tied) | 172Ω Nominal |
| 12. Turns Ratio: | 1:1 (tie 6&7) |
| | 2:1 (5 tied to 6 and 7 tied to 8) |
| 13. Dielectric Strength | 1500V Primary to Secondary |

Outline Dimensions:

- | | |
|----------------|----------|
| A. Dimensions: | As shown |
| B. Weight: | 0.4 oz. |

Frequency Response:

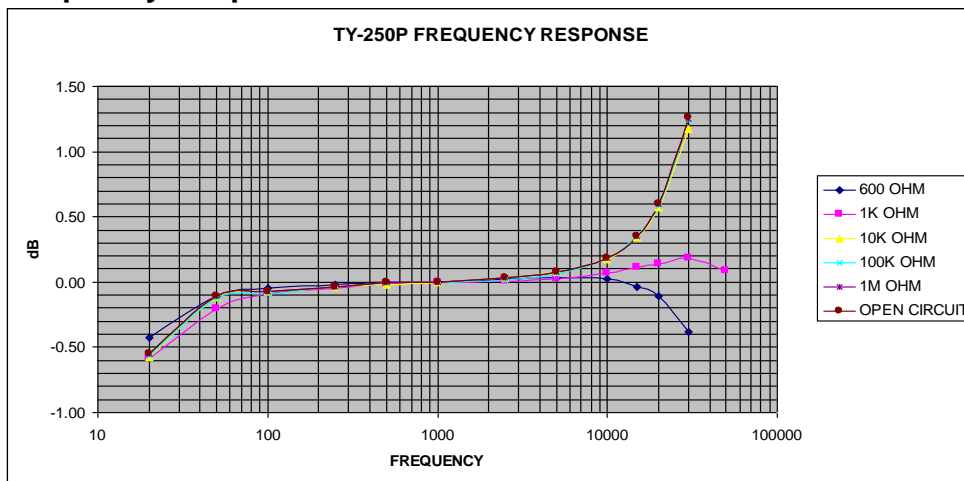

* 600:600Ω, 10K:10KΩ, 100K:100KΩ, 1M:1MΩ, and other impedances (secondaries can all be used at ¼ value when placed in parallel) are optional as long as input voltage is ≤4.2Vrms and current is ≤7mA.

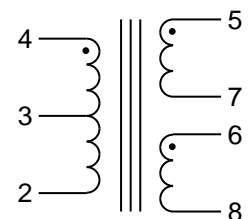
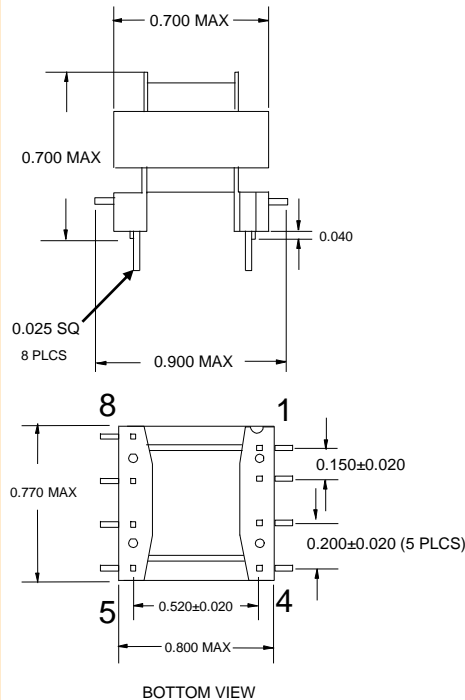
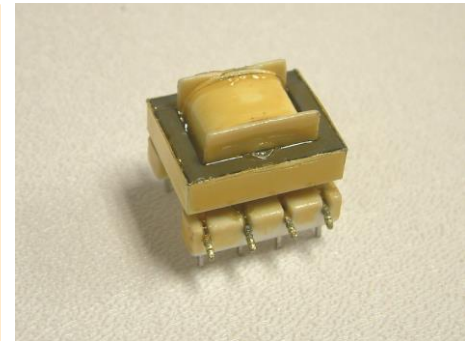

RoHS Compliance: As of manufacturing date February 2016, all standard products meet the requirements of 2015/863/EU, known as the RoHS 3 initiative.

*Upon printing, this document is considered "uncontrolled". Please contact Triad Magnetics website for the most current version. For soldering and washing information please see <http://www.triadmagnetics.com/faq.html>



Looking for pricing, stock, or lifecycle information?

Click below to explore more details on WIN SOURCE:

-  [View TY-250P](#) on WIN SOURCE
-  [Triad Magnetics](#) Information

Optimize Your Supply Chain with WIN SOURCE Solutions

-  Global Sourcing Solution
-  Obsolete Management
-  Cost Control Management
-  Shortage Management
-  Alternative Solution
-  Excess Inventory Management