



THE DATASHEET OF INA114AP



INA114 Precision Instrumentation Amplifier

1 Features

- Low offset voltage: 50μV maximum for high gains
- Low drift: 0.3μV/°C maximum for high gains
- Low input bias current: 2nA maximum
- High common-mode rejection: 115dB minimum
- Input over-voltage protection: ±40V
- Wide supply range: ±2.25V to ±18V
- Packages: PDIP-8 and SOIC-16

2 Applications

- [Surgical equipment](#)
- [Actuator](#)
- [Multifunction relay](#)
- [Train control and management](#)
- [Trackside signaling and control](#)

3 Description

The INA114 is a low-cost, general-purpose instrumentation amplifier offering excellent accuracy. The versatile three-op-amp design and small size make this device an excellent choice for a wide range of applications.

A single external resistor sets any gain from 1 to 10,000. Internal input protection withstands up to ±40V without damage.

The INA114 is laser trimmed for very low offset voltage (50μV), low drift (0.3μV/°C), and high common-mode rejection (115dB at G = 1000). The device operates with power supplies as low as ±2.25V, allowing use in battery-operated and single 5V supply systems.

The INA114 is available in 8-pin PDIP and 16-pin SOIC surface-mount packages. Both are specified for a temperature range of -40°C to +85°C.

Package Information

PART NUMBER	PACKAGE ⁽¹⁾	PACKAGE SIZE ⁽²⁾
INA114	P (PDIP, 8)	9.81mm × 9.43mm
	DW (SOIC, 16)	10.3mm × 10.3mm

(1) For more information, see [Section 10](#).

(2) The package size (length × width) is a nominal value and includes pins, where applicable.

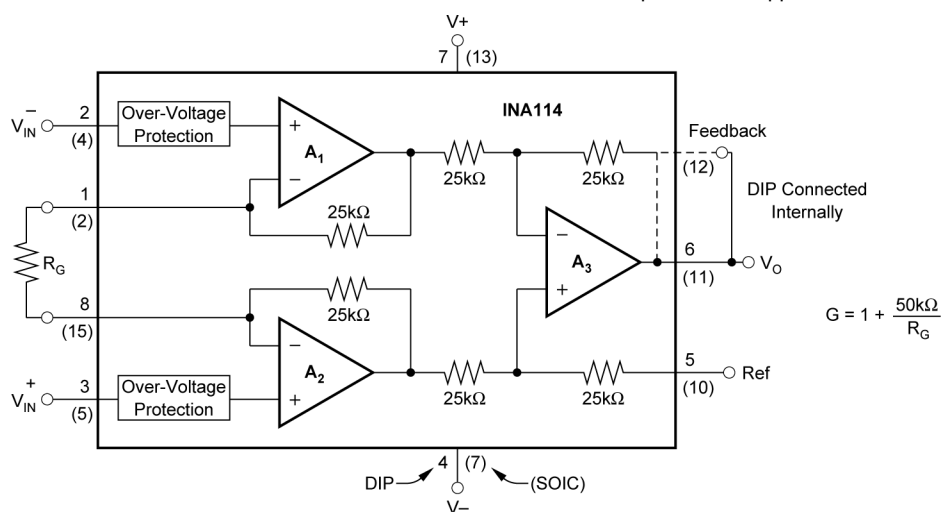

Schematic



Table of Contents

1 Features	1	6.1 Application Information.....	10
2 Applications	1	7 Typical Applications	15
3 Description	1	8 Device and Documentation Support	18
4 Pin Configuration and Functions	2	8.1 Receiving Notification of Documentation Updates....	18
5 Specifications	3	8.2 Support Resources.....	18
5.1 Absolute Maximum Ratings.....	3	8.3 Trademarks.....	18
5.2 ESD Ratings	3	8.4 Electrostatic Discharge Caution.....	18
5.3 Recommended Operating Conditions.....	3	8.5 Glossary.....	18
5.4 Thermal Information.....	3	9 Revision History	18
5.5 Electrical Characteristics.....	4	10 Mechanical, Packaging, and Orderable Information	19
5.6 Typical Characteristics.....	6		
6 Application and Implementation	10		

4 Pin Configuration and Functions

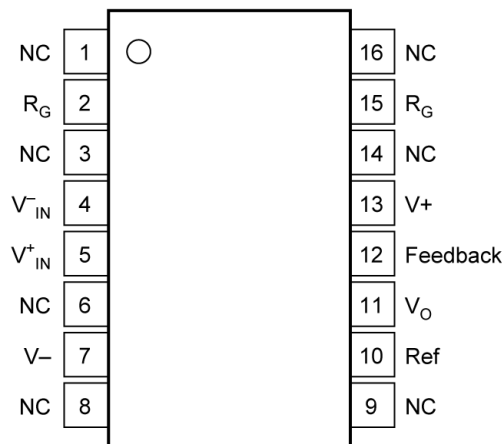

Figure 4-1. DW Package, 16-Pin SOIC (Top View)

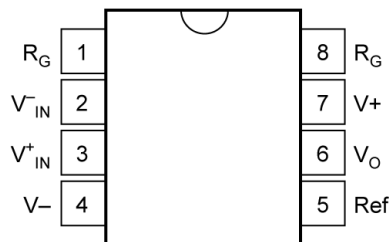

Figure 4-2. P Package, 8-Pin PDIP (Top View)

5 Specifications

5.1 Absolute Maximum Ratings

over operating free-air temperature range (unless otherwise noted)⁽¹⁾

			MIN	MAX	UNIT
V _S	Supply voltage	Single supply, V _S = (+V _S)		36	V
		Dual supply, V _S = (+V _S) – (–V _S)	–18	18	V
	Signal input pins		–40	40	V
V _O	Signal output voltage		(–V _S) – 0.5	(+V _S) + 0.5	V
I _S	Output short-circuit (to V _S /2)		Continuous		
T _A	Operating temperature		–40	125	°C
T _J	Junction temperature			150	°C
T _{stg}	Storage temperature		–40	125	°C

- (1) Operation outside the *Absolute Maximum Ratings* may cause permanent device damage. *Absolute Maximum Ratings* do not imply functional operation of the device at these or any other conditions beyond those listed under *Recommended Operating Conditions*. If used outside the *Recommended Operating Conditions* but within the *Absolute Maximum Ratings*, the device may not be fully functional, and this may affect device reliability, functionality, performance, and shorten the device lifetime.

5.2 ESD Ratings

			VALUE	UNIT
V _(ESD)	Electrostatic discharge	Human-body model (HBM), per ANSI/ESDA/JEDEC JS-001 ⁽¹⁾	±1500	V
		Charged-device model (CDM), per ANSI/ESDA/JEDEC JS-002 ⁽²⁾	±1500	

- (1) JEDEC document JEP155 states that 500V HBM allows safe manufacturing with a standard ESD control process.
(2) JEDEC document JEP157 states that 250V CDM allows safe manufacturing with a standard ESD control process.

5.3 Recommended Operating Conditions

over operating free-air temperature range (unless otherwise noted)

			MIN	MAX	UNIT
V _S	Supply voltage	Single supply, V _S = (+V _S)	4.5	36	V
		Dual supply, V _S = (+V _S) – (–V _S)	±2.25	±18	
T _A	Specified temperature		–40	85	°C

5.4 Thermal Information

THERMAL METRIC ⁽¹⁾		INA114		UNIT
		DW (SOIC)	P (PDIP)	
		16 PINS	8 PINS	
R _{θJA}	Junction-to-ambient thermal resistance	74.2	110.2	°C/W

- (1) For more information about traditional and new thermal metrics, see the [Semiconductor and IC Package Thermal Metrics](#) application report.

5.5 Electrical Characteristics

at $T_A = 25^\circ\text{C}$, $V_S = \pm 15\text{V}$, $R_L = 2\text{k}\Omega$, $V_{\text{REF}} = 0\text{V}$, and $G = 1$ (unless otherwise noted)

PARAMETER		TEST CONDITIONS		MIN	TYP	MAX	UNIT	
INPUT								
V_{OS}	Offset voltage	RTI	INA114BP, BU	$\pm 10 + 20/G$	$\pm 50 + 150/G$		μV	
			INA114AP, AU	$\pm 25 + 30/G$	$\pm 125 + 500/G$			
	Offset voltage drift	$T_A = -40^\circ\text{C}$ to $+85^\circ\text{C}$, RTI	INA114BP, BU	$\pm 0.1 + 0.5/G$	$\pm 0.3 + 5/G$		$\mu\text{V}/^\circ\text{C}$	
			INA114AP, AU	$\pm 0.25 + 5/G$	$\pm 1 + 10/G$			
	Long-term stability			$\pm 0.2 + 0.5/G$			$\mu\text{V}/\text{mo}$	
	Differential impedance			100 6			$\text{G}\Omega$ pF	
	Common-mode impedance			100 6			$\text{G}\Omega$ pF	
	Operating input voltage			$(V-) + 4$		$(V+) - 4$	V	
PSRR	Power-supply rejection ratio	RTI, $\pm 2.25\text{V}$ to $\pm 18\text{V}$			$0.5 + 2/G$	$3 + 10/G$	$\mu\text{V}/\text{V}$	
CMRR	Common-mode rejection ratio	At dc to 60Hz, RTI, $V_{\text{CM}} = \pm 10\text{V}$, $\Delta R_S = 1\text{k}\Omega$	G = 1	INA114BP, BU	80	96		dB
				INA114AP, AU	75	90		
			G = 10	INA114BP, BU	96	115		dB
				INA114AP, AU	90	106		
			G = 100	INA114BP, BU	110	120		dB
				INA114AP, AU	106	110		
			G = 1000	INA114BP, BU	115	120		dB
				INA114AP, AU	106	110		
BIAS CURRENT								
I_B	Input bias current	$V_{\text{CM}} = V_S / 2$	INA114BP, BU		± 0.5	± 2	nA	
			INA114AP, AU		± 0.5	± 5		
	Input bias current drift	$T_A = -40^\circ\text{C}$ to $+85^\circ\text{C}$	INA114BP, BU		± 8		$\text{pA}/^\circ\text{C}$	
			INA114AP, AU		± 8			
I_{OS}	Input offset current	$V_{\text{CM}} = V_S / 2$	INA114BP, BU		± 0.5	± 2	nA	
			INA114AP, AU		± 0.5	± 5		
	Input offset current drift	$T_A = -40^\circ\text{C}$ to $+85^\circ\text{C}$	INA114BP, BU		± 8		$\text{pA}/^\circ\text{C}$	
			INA114AP, AU		± 8			
NOISE VOLTAGE								
	Voltage noise	G = 1000, $R_S = 0\Omega$	f = 10Hz		15		nV/ $\sqrt{\text{Hz}}$	
			f = 100Hz		11			
			f = 1kHz		11			
			$f_B = 0.1\text{Hz}$ to 10Hz			0.4	μV_{PP}	
	Noise current	f = 10Hz			0.4		$\text{pA}/\sqrt{\text{Hz}}$	
		f = 1kHz			0.2		$\text{pA}/\sqrt{\text{Hz}}$	
		$f_B = 0.1\text{Hz}$ to 10Hz				18	pA_{PP}	

5.5 Electrical Characteristics (continued)

at $T_A = 25^\circ\text{C}$, $V_S = \pm 15\text{V}$, $R_L = 2\text{k}\Omega$, $V_{REF} = 0\text{V}$, and $G = 1$ (unless otherwise noted)

PARAMETER		TEST CONDITIONS		MIN	TYP	MAX	UNIT
GAIN							
G	Gain equation			1 + (50k Ω / R _G)			V/V
	Range of gain			1		10000	V/V
GE	Gain error	$V_O = \pm 10\text{V}$, $G = 1$			± 0.01	± 0.05	%
		$V_O = \pm 10\text{V}$	G = 10	INA114BP, BU	± 0.02	± 0.4	
				INA114AP, AU	± 0.02	± 0.5	
		$V_O = \pm 10\text{V}$	G = 100	INA114BP, BU	± 0.05	± 0.5	
				INA114AP, AU	± 0.05	± 0.7	
		$V_O = \pm 10\text{V}$	G = 1000	INA114BP, BU	± 0.5	± 1	
INA114AP, AU	± 0.5			± 2			
	Gain drift	$R_S = 50\text{k}\Omega^{(1)}$			± 2	± 10	ppm/ $^\circ\text{C}$
					± 25	± 100	
	Gain nonlinearity	$V_O = -10\text{V}$ to $+10\text{V}$	G = 1	INA114BP, BU	± 0.0001	± 0.001	% of FSR
				INA114AP, AU	± 0.0001	± 0.002	
			G = 10, 100	INA114BP, BU	± 0.0005	± 0.002	
				INA114AP, AU	± 0.0005	± 0.004	
			G = 1000	INA114BP, BU	± 0.002	± 0.01	
				INA114AP, AU	± 0.002	± 0.02	
OUTPUT							
	Output voltage	$I_O = 5\text{mA}$, $T_A = -40^\circ\text{C}$ to 85°C			(V-) +1.5	(V+) -1.5	V
			$V_S = \pm 11.4\text{V}$		(V-) + 1.4	(V+) - 1.4	
			$V_S = \pm 2.25\text{V}$		(V-) +1	(V+) - 1	
	Load capacitance stability			1000		pF	
I _{SC}	Short-circuit current	Continuous to $V_S / 2$		$+20 / -15$		mA	
FREQUENCY RESPONSE							
BW	Bandwidth, -3dB	G = 1		1		MHz	
		G = 10		100		kHz	
		G = 100		10			
		G = 1000		1			
SR	Slew rate	G = 10, $V_O = \pm 10\text{V}$		0.3	0.6	V/ μs	
t _S	Settling time	0.01%, $V_{STEP} = 10\text{V}$	G = 1	18		μs	
			G = 10	20			
			G = 100	120			
			G = 1000	1100			
	Overload recovery	50% overdrive		20		μs	
POWER SUPPLY							
I _Q	Quiescent current	$V_S = \pm 2.25\text{V}$ to $\pm 18\text{V}$, $V_{IN} = 0\text{V}$		± 2.2		± 3	mA

(1) Temperature coefficient of the "50k Ω " term in the gain equation.

5.6 Typical Characteristics

at $T_A = +25^\circ\text{C}$, $V_S = \pm 15\text{V}$, $G = 1\text{V/V}$ (unless otherwise noted)

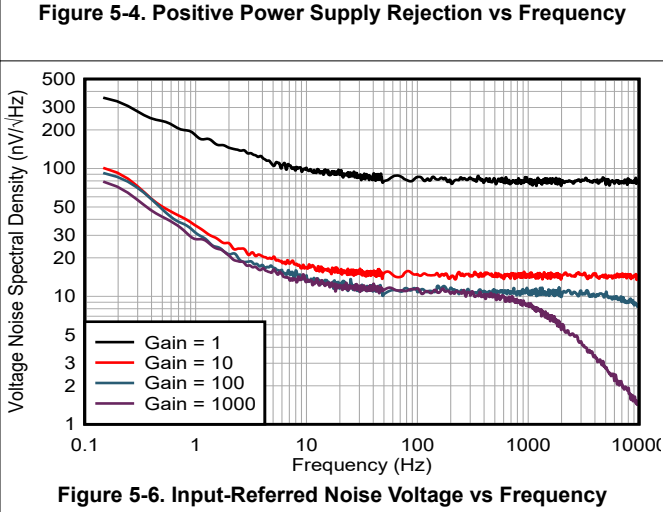
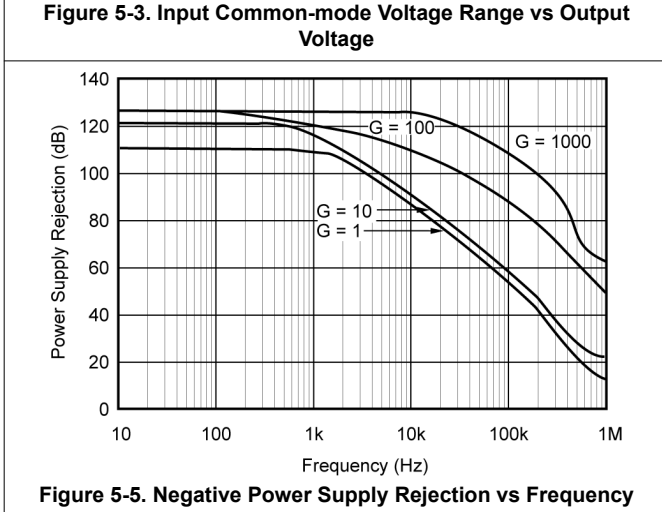
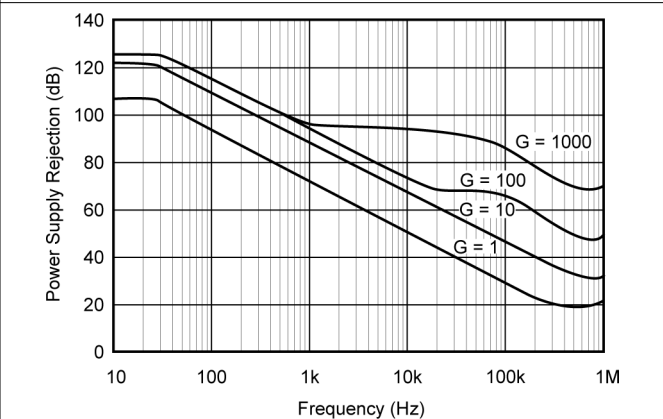
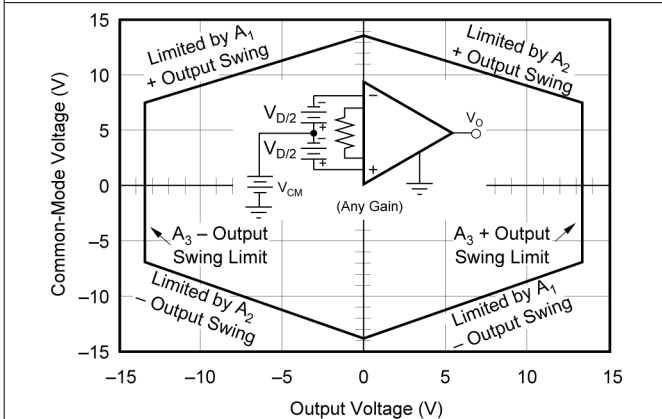
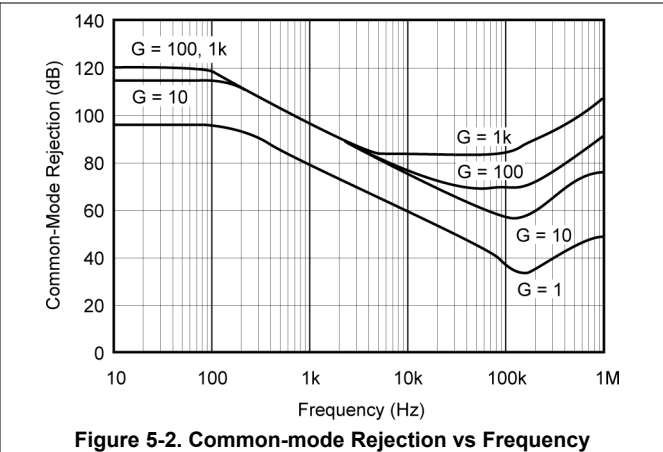
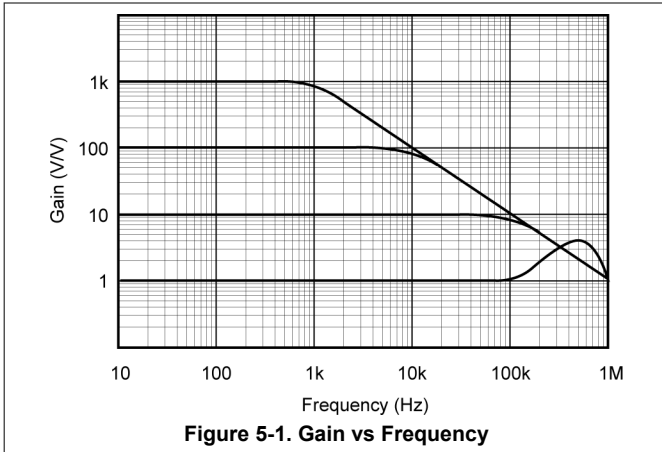

5.6 Typical Characteristics (continued)

at $T_A = +25^\circ\text{C}$, $V_S = \pm 15\text{V}$, $G = 1\text{V/V}$ (unless otherwise noted)

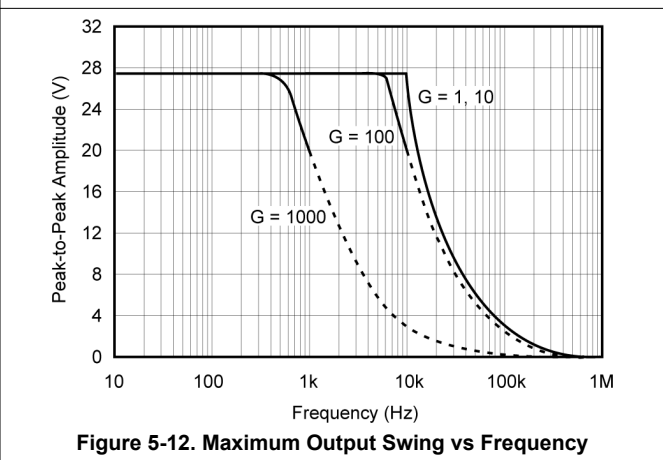
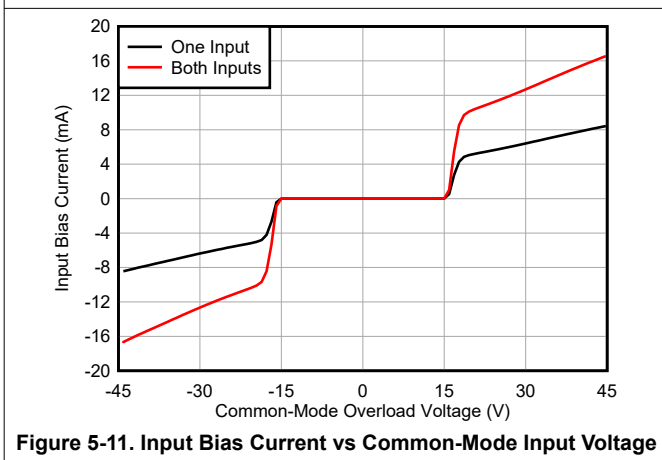
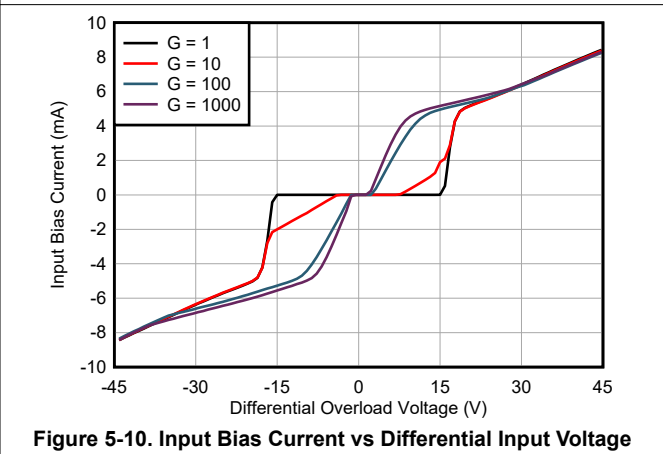
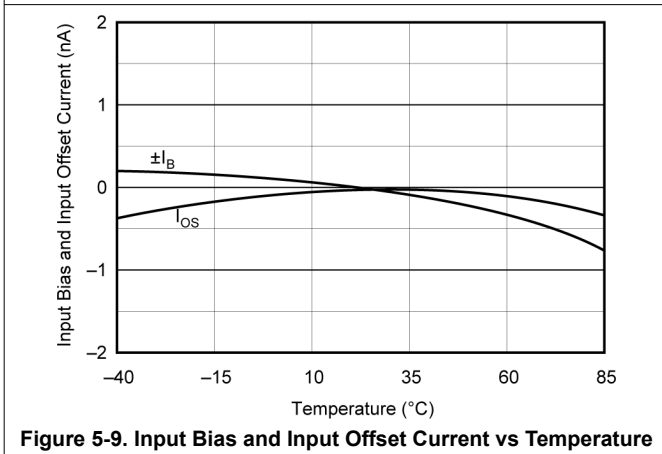
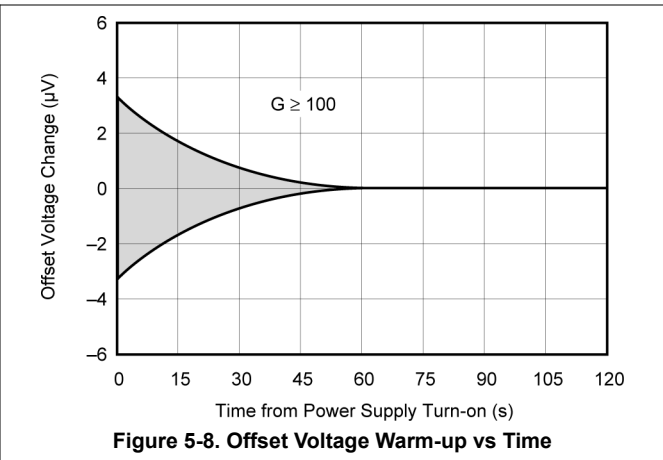
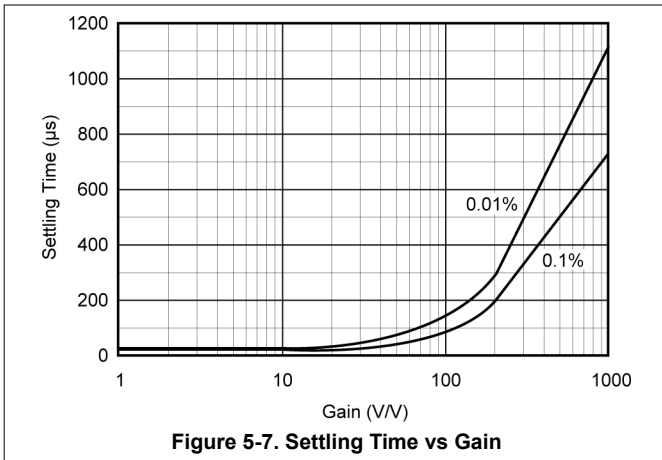

5.6 Typical Characteristics (continued)

at $T_A = +25^\circ\text{C}$, $V_S = \pm 15\text{V}$, $G = 1\text{V/V}$ (unless otherwise noted)

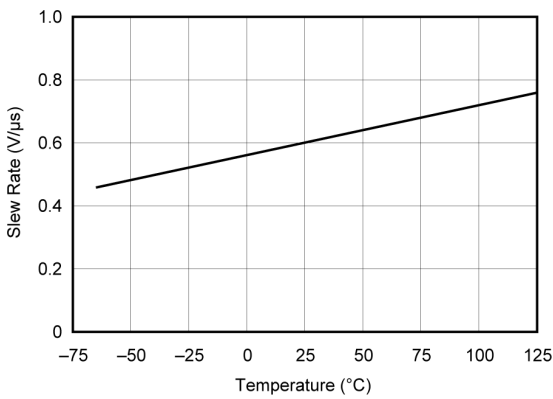

Figure 5-13. Slew Rate vs Temperature

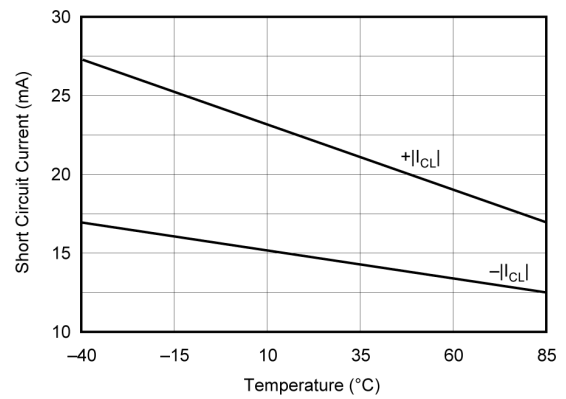

Figure 5-14. Output Current Limit vs Temperature

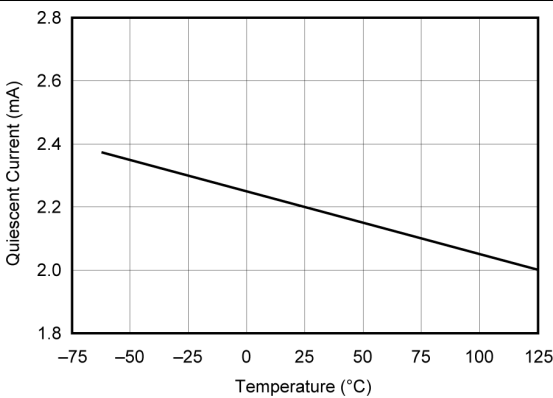

Figure 5-15. Quiescent Current vs Temperature

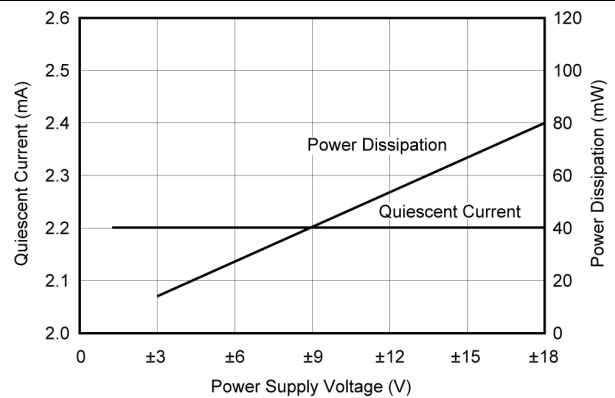

Figure 5-16. Quiescent Current and Power Dissipation vs Power Supply Voltage

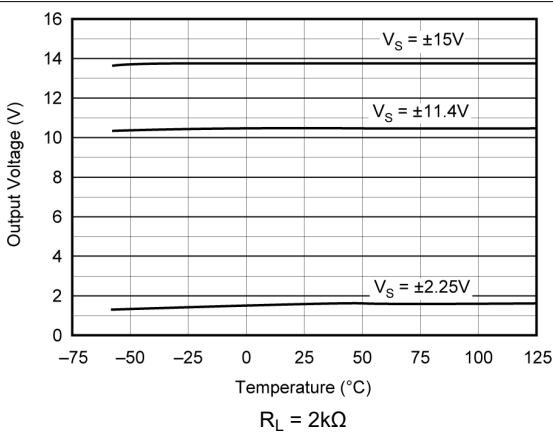

Figure 5-17. Positive Signal Swing vs Temperature

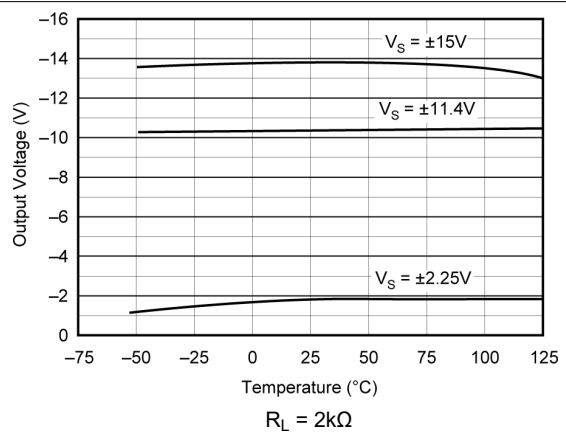

Figure 5-18. Negative Signal Swing vs Temperature

5.6 Typical Characteristics (continued)

at $T_A = +25^\circ\text{C}$, $V_S = \pm 15\text{V}$, $G = 1\text{V/V}$ (unless otherwise noted)

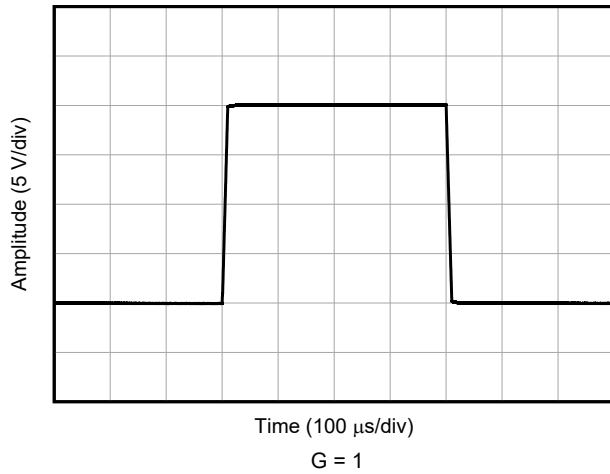

Figure 5-19. Large-Signal Response

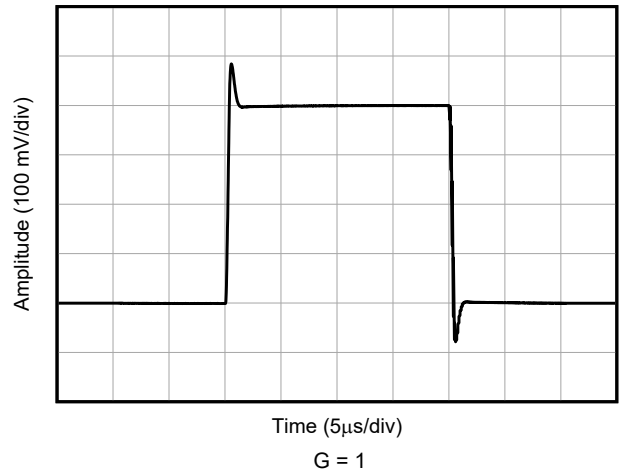

Figure 5-20. Small-Signal Response

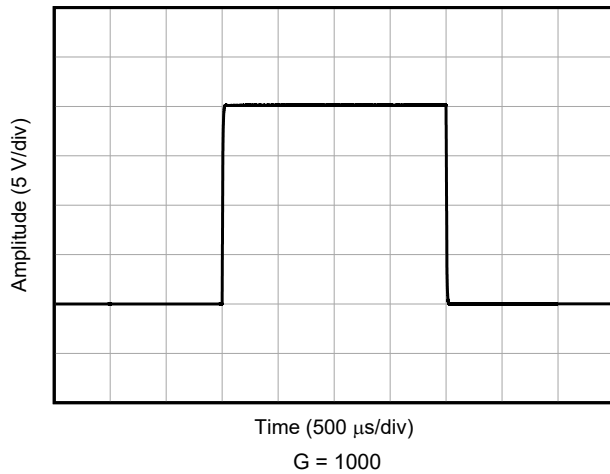

Figure 5-21. Large-Signal Response

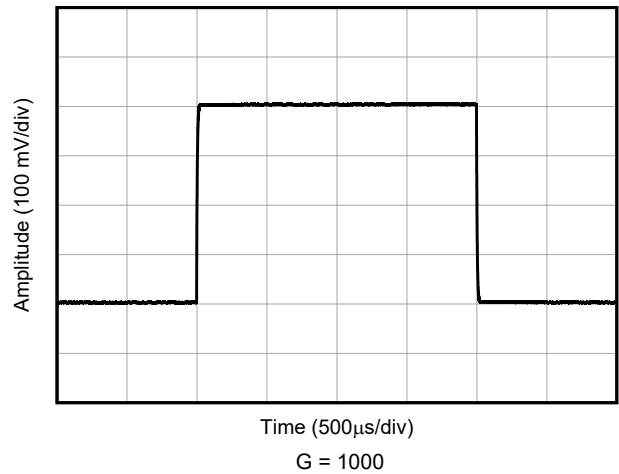

Figure 5-22. Small-Signal Response

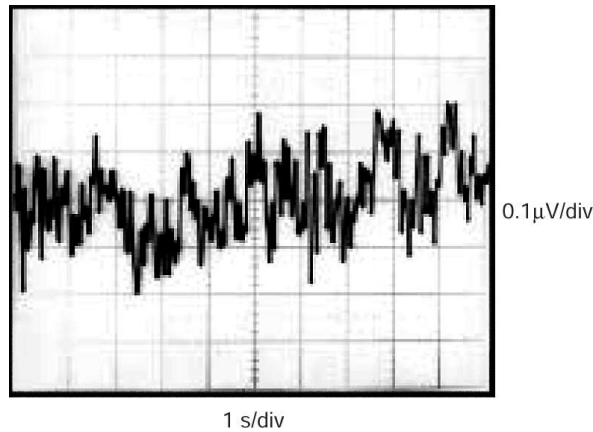

Figure 5-23. Input-Referred Noise, 0.1Hz to 10Hz

6 Application and Implementation

Note

Information in the following applications sections is not part of the TI component specification, and TI does not warrant its accuracy or completeness. TI's customers are responsible for determining suitability of components for their purposes, as well as validating and testing their design implementation to confirm system functionality.

6.1 Application Information

Figure 6-1 shows the basic connections required for operation of the INA114. Applications with noisy or high-impedance power supplies can require decoupling capacitors close to the device pins as shown.

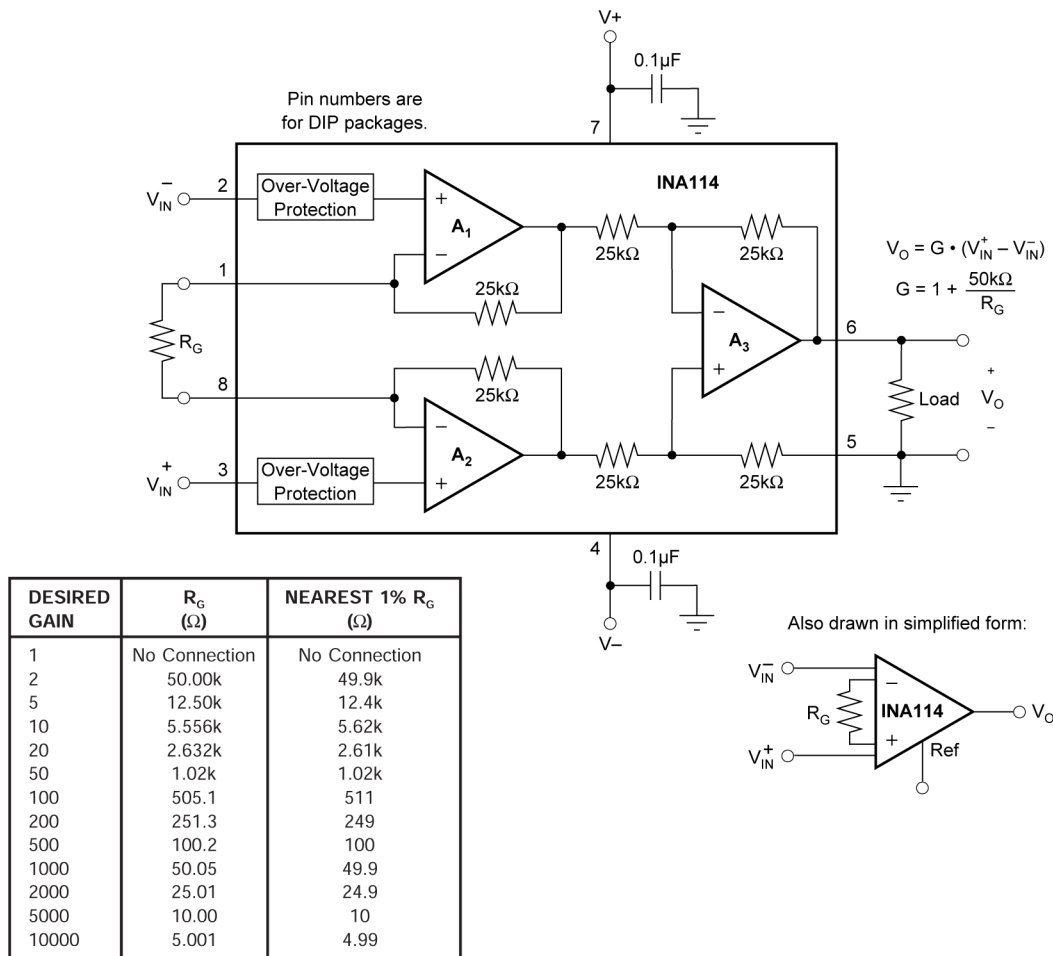

Figure 6-1. Basic Connections.

The output is referred to the output reference (Ref) pin, which is normally grounded. This connection must be low-impedance to provide good common-mode rejection. A resistance of 5 Ω in series with the Ref pin causes a typical device to degrade to approximately 80dB CMR ($G = 1$).

6.1.1 Setting the Gain

Gain of the INA114 is set by connecting a single external resistor, R_G :

$$G = 1 + \frac{50 \text{ k}\Omega}{R_G} \quad (1)$$

Figure 6-1 shows commonly used gains and resistor values.

The 50-k Ω term in Equation 1 comes from the sum of the two internal feedback resistors. These resistors are on-chip metal film resistors which are laser trimmed to accurate absolute values. The accuracy and temperature coefficient of these resistors are included in the gain accuracy and drift specifications of the INA114.

The stability and temperature drift of the external gain setting resistor, R_G , also affects gain. The contribution of R_G to gain accuracy and drift is directly inferred from the gain Equation 1. Low resistor values required for high gain can make wiring resistance important. Sockets add to the wiring resistance, which contributes additional gain error (possibly an unstable gain error) in gains of approximately 100 or greater.

6.1.2 Noise Performance

The INA114 provides very low noise in most applications. For differential source impedances less than 1k Ω , the INA103 can provide lower noise. For source impedances greater than 50k Ω , the INA111 FET-input instrumentation amplifier can provide lower noise.

Low frequency noise of the INA114 is approximately 0.4 μ V_{PP} measured from 0.1Hz to 10Hz. This noise is approximately one-tenth the noise of *low noise* chopper-stabilized amplifiers.

6.1.3 Offset Trimming

The INA114 is laser trimmed for very low offset voltage and drift. Most applications require no external offset adjustment. Figure 6-2 shows an optional circuit for trimming the output offset voltage. The voltage applied to the Ref pin is summed at the output. Maintain low impedance at this node to maintain good common-mode rejection by buffering trim voltage with an op amp as shown.

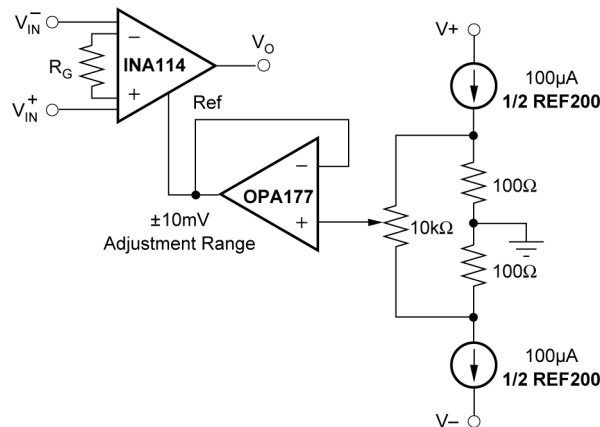

Figure 6-2. Optional Trimming of Output Offset Voltage.

6.1.4 Input Bias Current Return Path

The input impedance of the INA114 is extremely high—approximately $10^{10}\Omega$. However, a path must be provided for the input bias current of both inputs. This input bias current is typically less than $\pm 1\text{nA}$, and can be either polarity as a result of cancellation circuitry. High input impedance means that this input bias current changes very little with varying input voltage.

Input circuitry must provide a path for this input bias current if the INA114 is to operate properly. [Figure 6-3](#) shows various provisions for an input bias current path. Without a bias current return path, the inputs float to a potential that exceeds the common-mode range of the INA114 and the input amplifiers saturate. If the differential source resistance is low, the bias current return path can be connected to one input (see thermocouple example in [Figure 6-3](#)). With higher source impedance, use two resistors to provide a balanced input, with the possible advantages of lower input offset voltage due to bias current and better common-mode rejection.

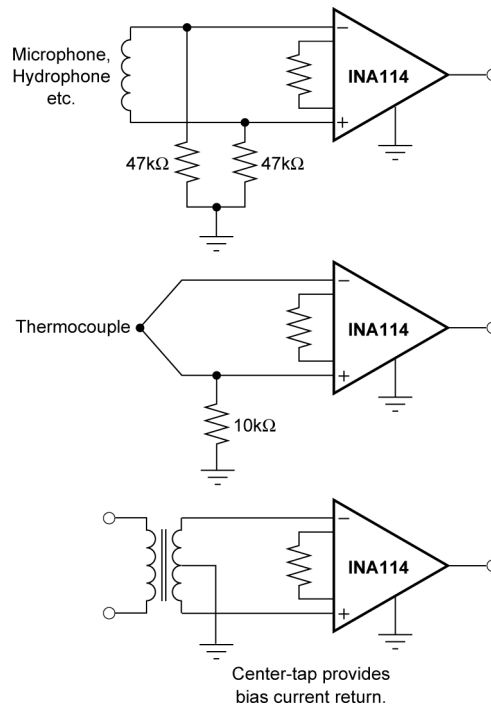

Figure 6-3. Providing an Input Common-Mode Current Path.

6.1.5 Input Common-Mode Range

The linear common-mode range of the input op amps of the INA114 is approximately $\pm 13.75\text{V}$ (or 1.25V from the power supplies). As the output voltage increases, however, the linear input range is limited by the output voltage swing of the input amplifiers, A_1 and A_2 . The common-mode range is related to the output voltage of the complete amplifier—see typical characteristic curve *Input Common-Mode Range vs Output Voltage*.

A combination of common-mode and differential input signals can cause the output of A_1 or A_2 to saturate. Figure 6-4 shows the output voltage swing of A_1 and A_2 expressed in terms of a common-mode and differential input voltages. Output swing capability of these internal amplifiers is the same as the output amplifier, A_3 . For applications where input common-mode range must be maximized, limit the output voltage swing by connecting the INA114 in a lower gain (see performance curve *Input Common-Mode Voltage Range vs Output Voltage*). If necessary, add gain after the INA114 to increase the voltage swing.

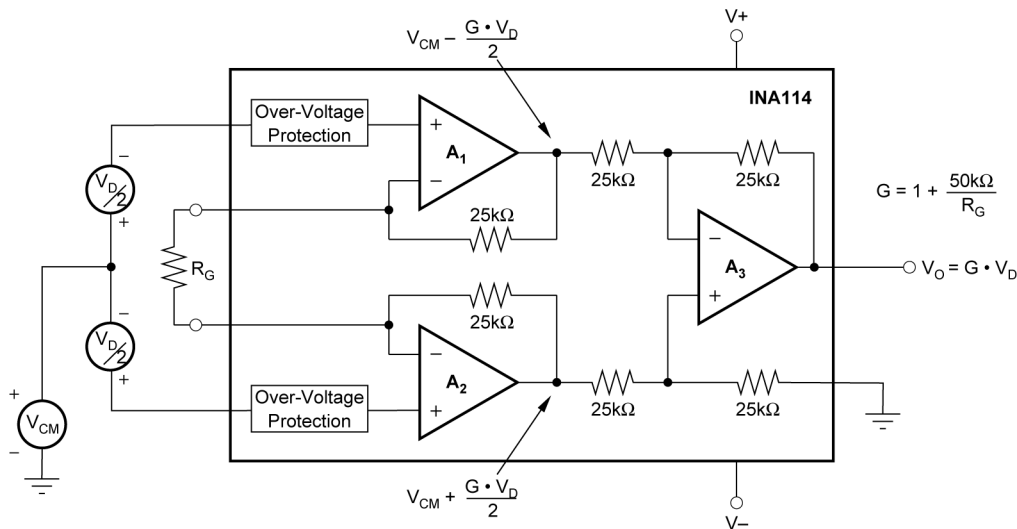

Figure 6-4. Voltage Swing of A_1 and A_2

Input overload often produces an output voltage that appears normal. For example, an input voltage of 20V on one input and 40V on the other input obviously exceeds the linear common-mode range of both input amplifiers. Both input amplifiers are saturated to nearly the same output voltage limit; therefore, the difference voltage measured by the output amplifier is near zero. The output of the INA114 is near 0V even though both inputs are overloaded.

6.1.6 Input Protection

The inputs of the INA114 are individually protected for voltages up to $\pm 40\text{V}$. For example, a condition of -40V on one input and $+40\text{V}$ on the other input does not cause damage. Internal circuitry on each input provides low series impedance under normal signal conditions. To provide equivalent protection, series input resistors contribute excessive noise. If the input is overloaded, the protection circuitry limits the input current to a safe value (approximately 1.5mA). Typical performance curve *Input Bias Current vs Common-Mode Input Voltage* shows this input current limit behavior. The inputs are protected even if no power supply voltage is present.

6.1.7 Output Voltage Sense (SOIC-16 Package Only)

The surface-mount version of the INA114 has a separate output sense feedback connection (pin 12). Pin 12 must be connected to the output terminal (pin 11) for proper operation. (This connection is made internally on the DIP version of the INA114.)

The output sense connection can be used to sense the output voltage directly at the load for best accuracy. Figure 6-5 shows how to drive a load through series interconnection resistance. Remotely located feedback paths can cause instability. This instability can be generally be eliminated with a high-frequency feedback path through C_1 . Drive heavy loads or long lines by connecting a buffer inside the feedback path (see Figure 6-6).

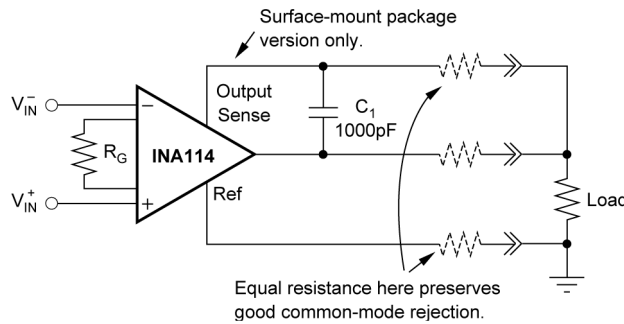

Figure 6-5. Remote Load and Ground Sensing

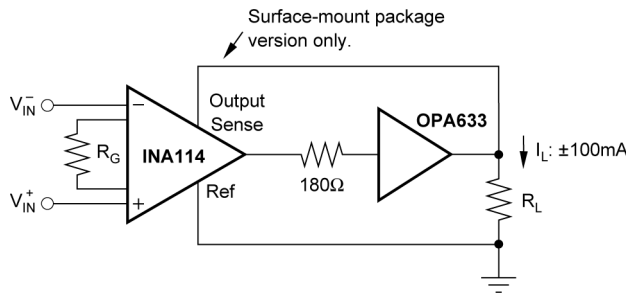

Figure 6-6. Buffered Output for Heavy Loads

7 Typical Applications

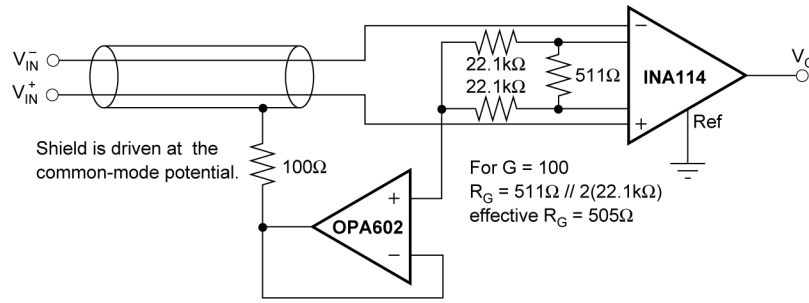

Figure 7-1. Shield Driver Circuit

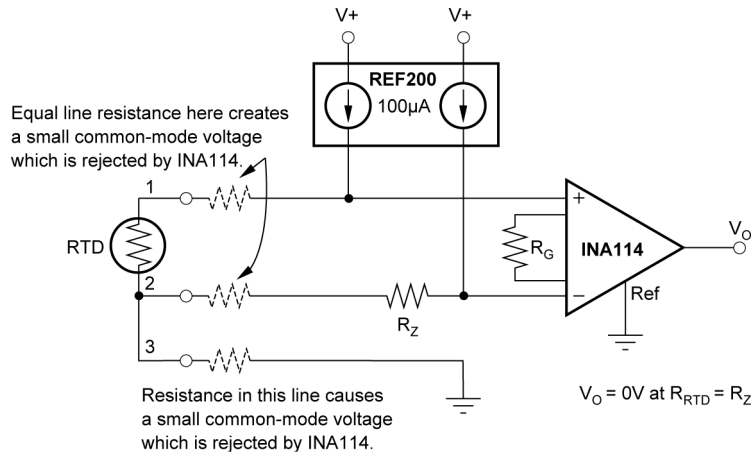
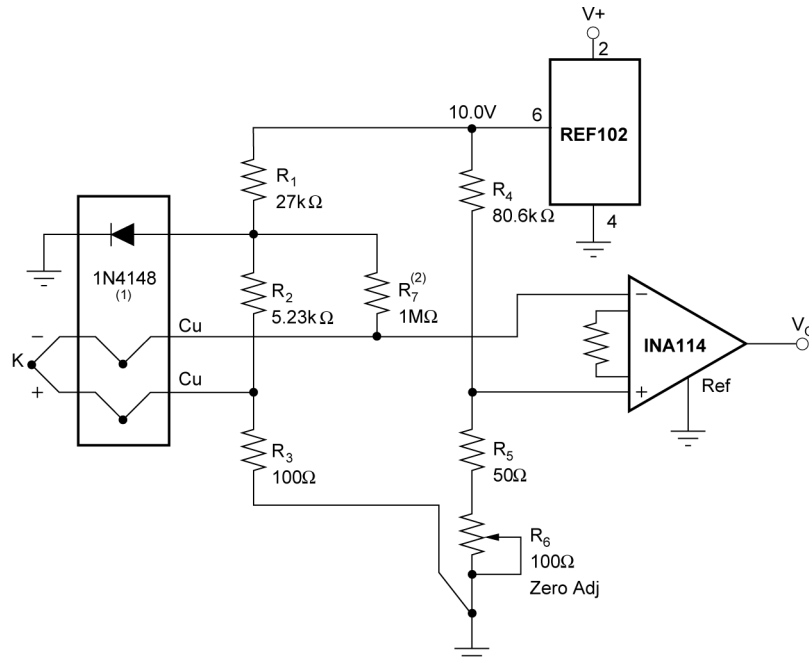

Figure 7-2. RTD Temperature Measurement Circuit



ISA TYPE	MATERIAL	SEEBECK COEFFICIENT (μV/°C)	R ₂ (R ₃ = 100Ω)	R ₄ (R ₅ + R ₆ = 100Ω)
E	Chromel Constantan	58.5	3.48kΩ	56.2kΩ
J	Iron Constantan	50.2	4.12kΩ	64.9kΩ
K	Chromel Alumel	39.4	5.23kΩ	80.6kΩ
T	Copper Constantan	38.0	5.49kΩ	84.5kΩ

NOTES: (1) -2.1mV/°C at 200μA. (2) R₇ provides down-scale burn-out indication.

Figure 7-3. Thermocouple Amplifier with Cold Junction Compensation

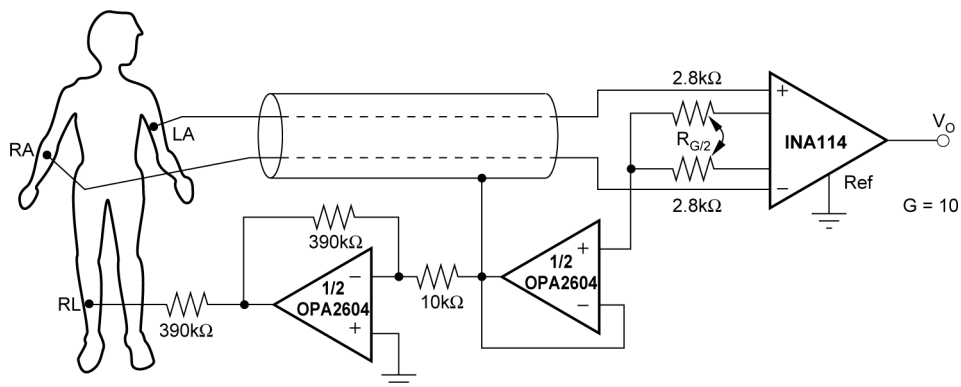

Figure 7-4. ECG Amplifier with Right-Leg Drive

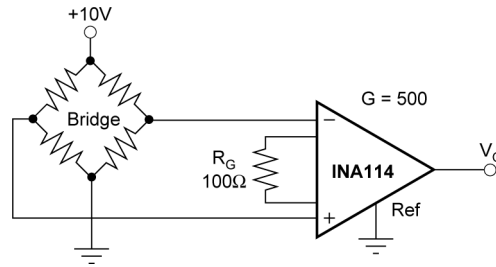

Figure 7-5. Bridge Transducer Amplifier

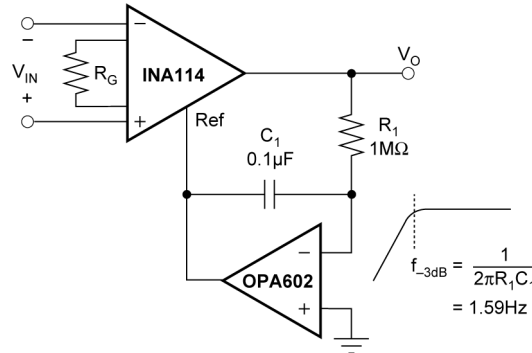
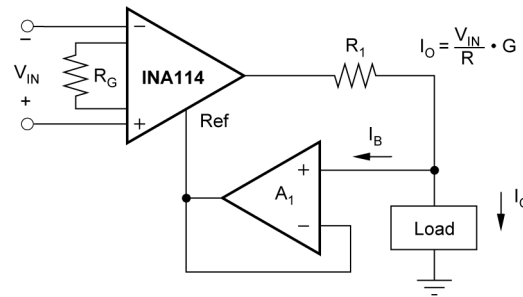

Figure 7-6. AC-Coupled Instrumentation Amplifier



A ₁	I _B Error
OPA177	±1.5nA
OPA602	1pA
OPA128	75fA

Figure 7-7. Differential Voltage-to-Current Converter

8 Device and Documentation Support

TI offers an extensive line of development tools. Tools and software to evaluate the performance of the device, generate code, and develop solutions are listed below.

8.1 Receiving Notification of Documentation Updates

To receive notification of documentation updates, navigate to the device product folder on ti.com. Click on *Notifications* to register and receive a weekly digest of any product information that has changed. For change details, review the revision history included in any revised document.

8.2 Support Resources

TI E2E™ support forums are an engineer's go-to source for fast, verified answers and design help — straight from the experts. Search existing answers or ask your own question to get the quick design help you need.

Linked content is provided "AS IS" by the respective contributors. They do not constitute TI specifications and do not necessarily reflect TI's views; see TI's [Terms of Use](#).

8.3 Trademarks

TI E2E™ is a trademark of Texas Instruments.

All trademarks are the property of their respective owners.

8.4 Electrostatic Discharge Caution



This integrated circuit can be damaged by ESD. Texas Instruments recommends that all integrated circuits be handled with appropriate precautions. Failure to observe proper handling and installation procedures can cause damage.

ESD damage can range from subtle performance degradation to complete device failure. Precision integrated circuits may be more susceptible to damage because very small parametric changes could cause the device not to meet its published specifications.

8.5 Glossary

[TI Glossary](#) This glossary lists and explains terms, acronyms, and definitions.

9 Revision History

NOTE: Page numbers for previous revisions may differ from page numbers in the current version.

Changes from Revision * (March 1998) to Revision A (January 2024)	Page
• Updated the numbering format for tables, figures, and cross-references throughout the document.....	1
• Added the <i>ESD Ratings, Recommended Operating Conditions, Thermal Information, Application and Implementation, Typical Applications, Device and Documentation Support, and Mechanical, Packaging, and Orderable Information</i> sections.....	1
• Changed SOL package name to SOIC throughout data sheet.....	1
• Added "for high gains" to low offset voltage and low drift bullets in <i>Features</i>	1
• Changed low drift bullet value from 0.25µV/°C to 0.3µV/°C in <i>Features</i>	1
• Updated bullets in <i>Applications</i>	1
• Added symbols in <i>Absolute Maximum Ratings</i>	3
• Changed supply voltage to show dual supply and single supply in <i>Absolute Maximum Ratings</i>	3
• Changed "Input Voltage Range" to "Signal input pins" in <i>Absolute Maximum Ratings</i>	3
• Added signal output voltage to <i>Absolute Maximum Ratings</i>	3
• Changed output short-circuit from "ground" to "V _S / 2" in <i>Absolute Maximum Ratings</i>	3
• Added DW (SOIC) package ambient thermal resistance value.....	3
• Changed ambient thermal resistance value for P (PDIP) package from 80°C/W to 110.2°C/W.....	3
• Added symbols in <i>Electrical Characteristics</i>	4
• Changed offset voltage maximum value from ±50 + 100/G to ±50 + 150/G.....	4
• Changed "Offset Voltage vs Temperature" to "Offset voltage drift".....	4
• Changed offset voltage drift test condition from T _A = T _{MIN} to T _{MAX} to T _A = –40°C to +85°C.....	4

• Changed offset voltage drift maximum value from $\pm 0.25 + 5/G$ to $\pm 0.3 + 5/G$	4
• Deleted safe input voltage from <i>Electrical Characteristics</i>	4
• Changed "Input Common-Mode Range" to "Operating input voltage".....	4
• Changed "Offset Voltage vs Power Supply" to "Power-supply rejection ratio".....	4
• Changed "Bias current vs Temperature" to "Input bias current drift".....	4
• Added " $T_A = -40^\circ\text{C}$ to $+85^\circ\text{C}$ " test condition to input bias current drift.....	4
• Changed "Offset Current vs Temperature" to "Input offset current drift".....	4
• Added " $T_A = -40^\circ\text{C}$ to $+85^\circ\text{C}$ " test condition to input offset current drift.....	4
• Added " $V_O = \pm 10\text{V}$ " test condition to gain error.....	4
• Changed "Gain vs Temperature" to "Gain drift".....	4
• Added " $V_O = -10\text{V}$ to $+10\text{V}$ " test condition to gain nonlinearity.....	4
• Changed output voltage values from ± 13.5 (min) and ± 13.7 (typ) to $(V-) + 1.5$ (min) and $(V+) - 1.5$ (max).....	4
• Changed output voltage test condition from T_{MIN} to T_{MAX} to $T_A = -40^\circ\text{C}$ to $+85^\circ\text{C}$	4
• Added output voltage test conditions for $V_S = \pm 11.4\text{V}$ and $V_S = \pm 2.25\text{V}$	4
• Added $V_{\text{STEP}} = 10\text{V}$ test condition to settling time.....	4
• Deleted power supply voltage range typical value of $\pm 15\text{V}$	4
• Moved voltage range, operating temperature range, and thermal resistance from <i>Electrical Characteristics</i> to <i>Recommended Operating Conditions</i> and <i>Thermal Information</i>	4
• Updated Figure 5-6, <i>Input-referred Noise Voltage vs Frequency</i>	6
• Updated Figure 5-10, <i>Input Bias Current vs Differential Input Voltage</i>	6
• Updated Figure 5-11, <i>Input Bias Current vs Common-Mode Input Voltage</i>	6
• Updated Figure 5-19 to Figure 22, Small- and Large-Signal Response plots.....	6

10 Mechanical, Packaging, and Orderable Information

The following pages include mechanical, packaging, and orderable information. This information is the most current data available for the designated devices. This data is subject to change without notice and revision of this document. For browser-based versions of this data sheet, refer to the left-hand navigation.

PACKAGING INFORMATION

Orderable Device	Status (1)	Package Type	Package Drawing	Pins	Package Qty	Eco Plan (2)	Lead finish/ Ball material (6)	MSL Peak Temp (3)	Op Temp (°C)	Device Marking (4/5)	Samples
INA114AP	ACTIVE	PDIP	P	8	50	RoHS & Green	NIPDAU	N / A for Pkg Type		INA114AP	Samples
INA114AU	ACTIVE	SOIC	DW	16	40	RoHS & Green	NIPDAU	Level-3-260C-168 HR	-40 to 85	INA114AU	Samples
INA114AU/1K	ACTIVE	SOIC	DW	16	1000	RoHS & Green	Call TI	Level-3-260C-168 HR	-40 to 85	INA114AU	Samples
INA114AUE4	LIFEBUY	SOIC	DW	16	40	RoHS & Green	NIPDAU	Level-3-260C-168 HR	-40 to 85	INA114AU	
INA114BP	ACTIVE	PDIP	P	8	50	RoHS & Green	NIPDAU	N / A for Pkg Type		INA114BP	Samples
INA114BU	ACTIVE	SOIC	DW	16	40	RoHS & Green	NIPDAU	Level-3-260C-168 HR		INA114BU	Samples
INA114BU/1K	ACTIVE	SOIC	DW	16	1000	RoHS & Green	Call TI	Level-3-260C-168 HR		INA114BU	Samples

(1) The marketing status values are defined as follows:

ACTIVE: Product device recommended for new designs.

LIFEBUY: TI has announced that the device will be discontinued, and a lifetime-buy period is in effect.

NRND: Not recommended for new designs. Device is in production to support existing customers, but TI does not recommend using this part in a new design.

PREVIEW: Device has been announced but is not in production. Samples may or may not be available.

OBSOLETE: TI has discontinued the production of the device.

(2) **RoHS:** TI defines "RoHS" to mean semiconductor products that are compliant with the current EU RoHS requirements for all 10 RoHS substances, including the requirement that RoHS substance do not exceed 0.1% by weight in homogeneous materials. Where designed to be soldered at high temperatures, "RoHS" products are suitable for use in specified lead-free processes. TI may reference these types of products as "Pb-Free".

RoHS Exempt: TI defines "RoHS Exempt" to mean products that contain lead but are compliant with EU RoHS pursuant to a specific EU RoHS exemption.

Green: TI defines "Green" to mean the content of Chlorine (Cl) and Bromine (Br) based flame retardants meet JS709B low halogen requirements of <=1000ppm threshold. Antimony trioxide based flame retardants must also meet the <=1000ppm threshold requirement.

(3) MSL, Peak Temp. - The Moisture Sensitivity Level rating according to the JEDEC industry standard classifications, and peak solder temperature.

(4) There may be additional marking, which relates to the logo, the lot trace code information, or the environmental category on the device.

(5) Multiple Device Markings will be inside parentheses. Only one Device Marking contained in parentheses and separated by a "~" will appear on a device. If a line is indented then it is a continuation of the previous line and the two combined represent the entire Device Marking for that device.

⁽⁶⁾ Lead finish/Ball material - Orderable Devices may have multiple material finish options. Finish options are separated by a vertical ruled line. Lead finish/Ball material values may wrap to two lines if the finish value exceeds the maximum column width.

Important Information and Disclaimer:The information provided on this page represents TI's knowledge and belief as of the date that it is provided. TI bases its knowledge and belief on information provided by third parties, and makes no representation or warranty as to the accuracy of such information. Efforts are underway to better integrate information from third parties. TI has taken and continues to take reasonable steps to provide representative and accurate information but may not have conducted destructive testing or chemical analysis on incoming materials and chemicals. TI and TI suppliers consider certain information to be proprietary, and thus CAS numbers and other limited information may not be available for release.

In no event shall TI's liability arising out of such information exceed the total purchase price of the TI part(s) at issue in this document sold by TI to Customer on an annual basis.

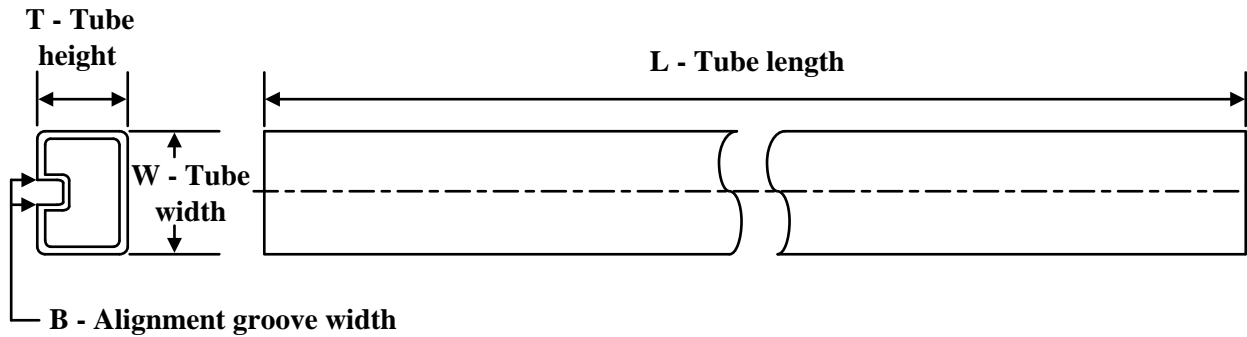
TUBE

*All dimensions are nominal

Device	Package Name	Package Type	Pins	SPQ	L (mm)	W (mm)	T (μm)	B (mm)
INA114AP	P	PDIP	8	50	506	13.97	11230	4.32
INA114AU	DW	SOIC	16	40	507	12.83	5080	6.6
INA114AU	DW	SOIC	16	40	507	12.83	5080	6.6
INA114AUE4	DW	SOIC	16	40	507	12.83	5080	6.6
INA114AUE4	DW	SOIC	16	40	507	12.83	5080	6.6
INA114BP	P	PDIP	8	50	506	13.97	11230	4.32
INA114BU	DW	SOIC	16	40	507	12.83	5080	6.6
INA114BU	DW	SOIC	16	40	507	12.83	5080	6.6

GENERIC PACKAGE VIEW

DW 16

SOIC - 2.65 mm max height

7.5 x 10.3, 1.27 mm pitch

SMALL OUTLINE INTEGRATED CIRCUIT

This image is a representation of the package family, actual package may vary.
Refer to the product data sheet for package details.



4224780/A



DW0016A

PACKAGE OUTLINE SOIC - 2.65 mm max height

SOIC

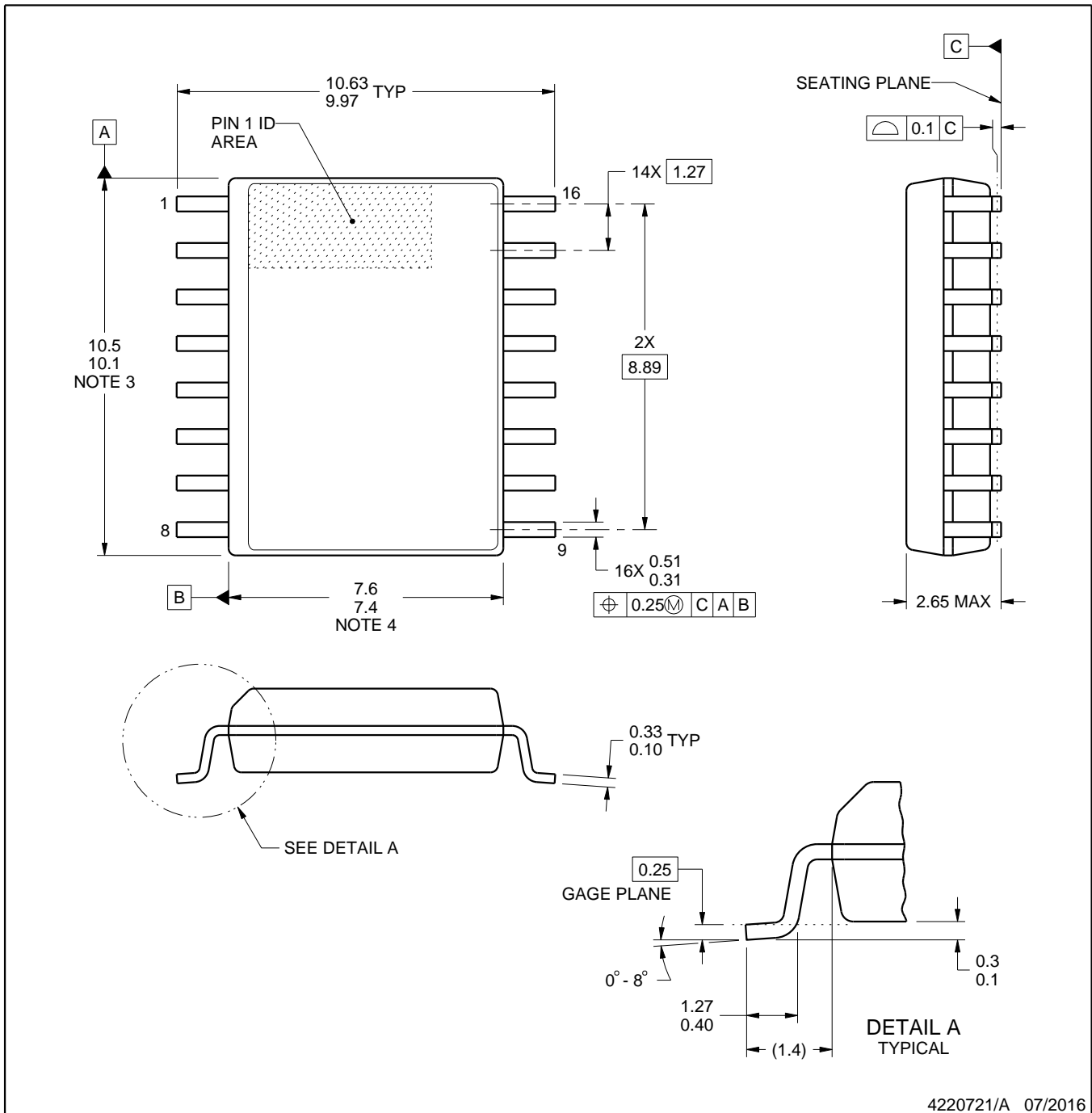

4220721/A 07/2016

NOTES:

1. All linear dimensions are in millimeters. Dimensions in parenthesis are for reference only. Dimensioning and tolerancing per ASME Y14.5M.
2. This drawing is subject to change without notice.
3. This dimension does not include mold flash, protrusions, or gate burrs. Mold flash, protrusions, or gate burrs shall not exceed 0.15 mm, per side.
4. This dimension does not include interlead flash. Interlead flash shall not exceed 0.25 mm, per side.
5. Reference JEDEC registration MS-013.

EXAMPLE BOARD LAYOUT

DW0016A

SOIC - 2.65 mm max height

SOIC



LAND PATTERN EXAMPLE
SCALE:7X



SOLDER MASK DETAILS

4220721/A 07/2016

NOTES: (continued)

6. Publication IPC-7351 may have alternate designs.

7. Solder mask tolerances between and around signal pads can vary based on board fabrication site.

EXAMPLE STENCIL DESIGN

DW0016A

SOIC - 2.65 mm max height

SOIC



SOLDER PASTE EXAMPLE
BASED ON 0.125 mm THICK STENCIL
SCALE:7X

4220721/A 07/2016

NOTES: (continued)

8. Laser cutting apertures with trapezoidal walls and rounded corners may offer better paste release. IPC-7525 may have alternate design recommendations.
9. Board assembly site may have different recommendations for stencil design.

P (R-PDIP-T8)

PLASTIC DUAL-IN-LINE PACKAGE



- NOTES:
- A. All linear dimensions are in inches (millimeters).
 - B. This drawing is subject to change without notice.
 - C. Falls within JEDEC MS-001 variation BA.

IMPORTANT NOTICE AND DISCLAIMER

TI PROVIDES TECHNICAL AND RELIABILITY DATA (INCLUDING DATA SHEETS), DESIGN RESOURCES (INCLUDING REFERENCE DESIGNS), APPLICATION OR OTHER DESIGN ADVICE, WEB TOOLS, SAFETY INFORMATION, AND OTHER RESOURCES "AS IS" AND WITH ALL FAULTS, AND DISCLAIMS ALL WARRANTIES, EXPRESS AND IMPLIED, INCLUDING WITHOUT LIMITATION ANY IMPLIED WARRANTIES OF MERCHANTABILITY, FITNESS FOR A PARTICULAR PURPOSE OR NON-INFRINGEMENT OF THIRD PARTY INTELLECTUAL PROPERTY RIGHTS.

These resources are intended for skilled developers designing with TI products. You are solely responsible for (1) selecting the appropriate TI products for your application, (2) designing, validating and testing your application, and (3) ensuring your application meets applicable standards, and any other safety, security, regulatory or other requirements.

These resources are subject to change without notice. TI grants you permission to use these resources only for development of an application that uses the TI products described in the resource. Other reproduction and display of these resources is prohibited. No license is granted to any other TI intellectual property right or to any third party intellectual property right. TI disclaims responsibility for, and you will fully indemnify TI and its representatives against, any claims, damages, costs, losses, and liabilities arising out of your use of these resources.

TI's products are provided subject to [TI's Terms of Sale](#) or other applicable terms available either on [ti.com](https://www.ti.com) or provided in conjunction with such TI products. TI's provision of these resources does not expand or otherwise alter TI's applicable warranties or warranty disclaimers for TI products.

TI objects to and rejects any additional or different terms you may have proposed.

Mailing Address: Texas Instruments, Post Office Box 655303, Dallas, Texas 75265
Copyright © 2024, Texas Instruments Incorporated

Looking for pricing, stock, or lifecycle information?

Click below to explore more details on WIN SOURCE:

 [View INA114AP](#) on WIN SOURCE

 [Texas Instruments](#) Information

Optimize Your Supply Chain with WIN SOURCE Solutions

-  Global Sourcing Solution
-  Obsolete Management
-  Cost Control Management
-  Shortage Management
-  Alternative Solution
-  Excess Inventory Management