

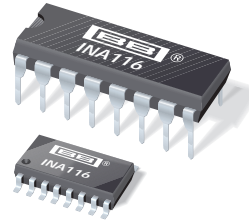

THE DATASHEET OF INA116UA





INA116

Ultra Low Input Bias Current INSTRUMENTATION AMPLIFIER

FEATURES

- **LOW INPUT BIAS CURRENT:** 3fA typ
- **BUFFERED GUARD DRIVE PINS**
- **LOW OFFSET VOLTAGE:** 2mV max
- **HIGH COMMON-MODE REJECTION:** 84dB (G = 10)
- **LOW QUIESCENT CURRENT:** 1mA
- **INPUT OVER-VOLTAGE PROTECTION:** ±40V

APPLICATIONS

- **LABORATORY INSTRUMENTATION**
- **pH MEASUREMENT**
- **ION-SPECIFIC PROBES**
- **LEAKAGE CURRENT MEASUREMENT**

DESCRIPTION

The INA116 is a complete monolithic FET-input instrumentation amplifier with extremely low input bias current. *Difet*[®] inputs and special guarding techniques yield input bias currents of 3fA at 25°C, and only 25fA at 85°C. Its 3-op amp topology allows gains to be set from 1 to 1000 by connecting a single external resistor.

Guard pins adjacent to both input connections can be used to drive circuit board and input cable guards to maintain extremely low input bias current.

The INA116 is available in 16-pin plastic DIP and SOL-16 surface-mount packages, specified for the -40°C to +85°C temperature range.

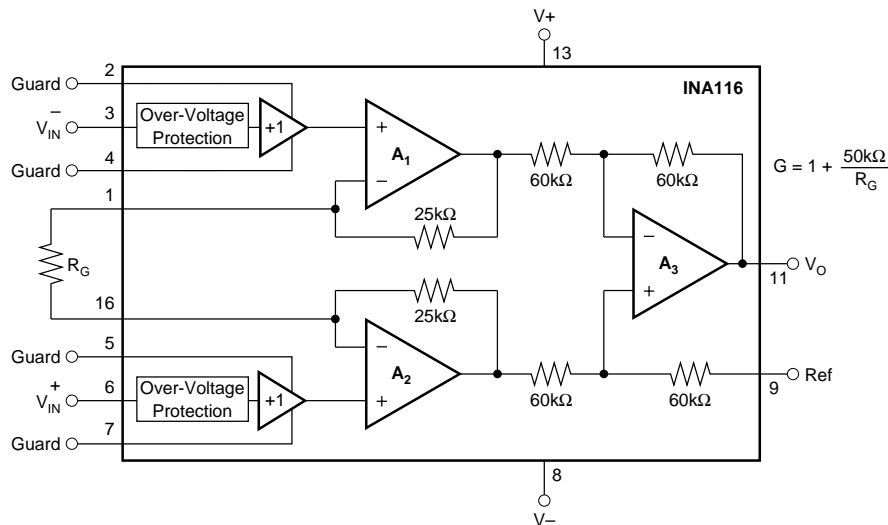

Difet[®]; Burr-Brown Corporation

International Airport Industrial Park • Mailing Address: PO Box 11400, Tucson, AZ 85734 • Street Address: 6730 S. Tucson Blvd., Tucson, AZ 85706 • Tel: (520) 746-1111 • Twx: 910-952-1111
Internet: <http://www.burr-brown.com/> • FAXLine: (800) 548-6133 (US/Canada Only) • Cable: BBRCORP • Telex: 066-6491 • FAX: (520) 889-1510 • Immediate Product Info: (800) 548-6132

SPECIFICATIONS

AT $T_A = +25^\circ\text{C}$, $V_S = \pm 15\text{V}$, $R_L = 10\text{k}\Omega$, unless otherwise noted.

PARAMETER	CONDITIONS	INA116P, U			INA116PA, UA			UNITS	
		MIN	TYP	MAX	MIN	TYP	MAX		
INPUT									
Offset Voltage, RTI	$T_A = +25^\circ\text{C}$ $T_A = T_{\text{MIN}}$ to T_{MAX} $V_S = \pm 4.5\text{V}$ to $\pm 18\text{V}$		$\pm 0.5 \pm 0.5/\text{G}$	$\pm 2 \pm 2/\text{G}$		*	$\pm 5 \pm 5/\text{G}$	mV	
Initial			See Typical Curve			*			
vs Temperature				$\pm 10 \pm 15/\text{G}$	$\pm 50 \pm 100/\text{G}$		*	$\pm 100 \pm 200/\text{G}$	$\mu\text{V}/\text{V}$
vs Power Supply				$\pm 1 \pm 5/\text{G}$			*		$\mu\text{V}/\text{mV}$
Long-Term Stability				± 3	± 25		*	± 100	fA
Bias Current				See Typical Curve			*		
vs Temperature				± 1	± 25		*	± 100	fA
Offset Current				See Typical Curve			*		
vs Temperature				$>10^{15}/0.2$			*		Ω/pF
Impedance, Differential				$>10^{15}/7$			*		Ω/pF
Common-Mode			(V+)-4	(V+)-2	*	*		V	
Common-Mode Voltage Range		(V-)+4	(V-)+2.4		*	*		V	
Safe Input Voltage		± 40			*			V	
Common-Mode Rejection	$V_{\text{CM}} = \pm 11\text{V}$, $\Delta R_S = 1\text{k}\Omega$								
	G = 1	80	89		73	*		dB	
	G = 10	84	92		78	*		dB	
	G = 100	86	94		80	*		dB	
	$V_{\text{CM}} = \pm 5\text{V}$, G = 1000	86	94		80	*		dB	
NOISE									
Voltage Noise, RTI	G = 1000, $R_S = 0\Omega$								
f = 1kHz			28			*		$\text{nV}/\sqrt{\text{Hz}}$	
$f_B = 0.1\text{Hz}$ to 10Hz				2			*	$\mu\text{Vp-p}$	
Current Noise									
f = 1kHz			0.1			*		$\text{fA}/\sqrt{\text{Hz}}$	
GAIN									
Gain Equation			$1 + (50\text{k}\Omega/R_G)$			*		V/V	
Range of Gain		1		1000	*	*	*	V/V	
Gain Error	G = 1		± 0.01	± 0.05		*	0.1	%	
	G = 10		± 0.25	± 0.4		*	± 0.5	%	
	G = 100		± 0.35	± 0.5		*	± 0.7	%	
	G = 1000		± 1.25			*		%	
Gain vs Temperature ⁽¹⁾	G = 1		± 5	± 10		*	± 20	$\text{ppm}/^\circ\text{C}$	
50k Ω Resistance ⁽¹⁾⁽²⁾			± 25	± 100		*	± 100	$\text{ppm}/^\circ\text{C}$	
Nonlinearity	G = 1		± 0.0005	± 0.005		*	± 0.01	% of FSR	
	G = 10		± 0.001	± 0.005		*	± 0.01	% of FSR	
	G = 100		± 0.001	± 0.005		*	± 0.01	% of FSR	
	G = 1000		± 0.005			*		% of FSR	
GUARD OUTPUTS									
Offset Voltage			± 15	± 50		*	*	mV	
Output Impedance			650			*		Ω	
Current Drive			$+2/-0.05$			*		mA	
OUTPUT									
Voltage Positive	$R_L = 10\text{k}\Omega$	(V+) -1	(V+) -0.7		*	*		V	
Negative	$R_L = 10\text{k}\Omega$	(V-) +0.35	(V-) +0.2		*	*		V	
Load Capacitance Stability			1000			*		pF	
Short-Circuit Current			$+5/-12$			*		mA	
FREQUENCY RESPONSE									
Bandwidth, -3dB	G = 1		800			*		kHz	
	G = 10		500			*		kHz	
	G = 100		70			*		kHz	
	G = 1000		7			*		kHz	
Slew Rate	G = 10 to 200		0.8			*		V/ μs	
Settling Time, 0.01%	10V Step, G = 1		22			*		μs	
	G = 10		25			*		μs	
	G = 100		145			*		μs	
	G = 1000		400			*		μs	
Output Overload Recovery	50% Overdrive		20			*		μs	
POWER SUPPLY									
Voltage Range		± 4.5	± 15	± 18	*	*	*	V	
Current	$V_{\text{IN}} = 0\text{V}$		± 1	± 1.4		*	*	mA	
TEMPERATURE RANGE									
Specification		-40		85	*		*	$^\circ\text{C}$	
Operating		-40		125	*		*	$^\circ\text{C}$	
θ_{JA}			80			*		$^\circ\text{C}/\text{W}$	

* Specification same as INA116P

NOTE: (1) Guaranteed by wafer test. (2) Temperature coefficient of the "50k Ω " term in the gain equation.

PIN CONFIGURATION

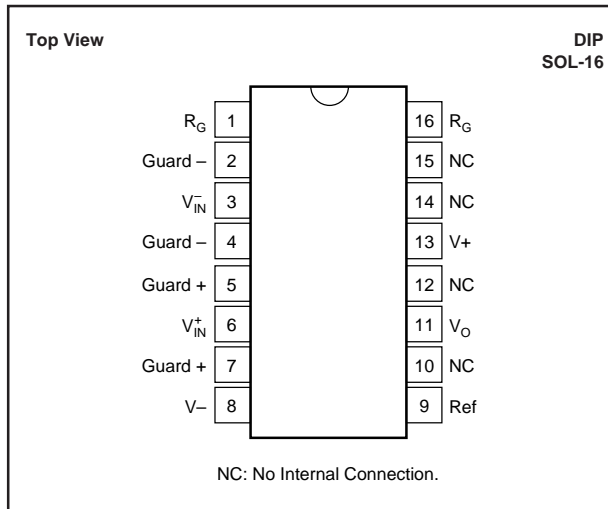

ABSOLUTE MAXIMUM RATINGS

Supply Voltage	±18V
Input Voltage Range	±40V
Output Short-Circuit (to ground)	Continuous
Operating Temperature	-40°C to +125°C
Storage Temperature	-40°C to +125°C
Junction Temperature	+150°C
Lead Temperature (soldering, 10s)	+300°C

ELECTROSTATIC DISCHARGE SENSITIVITY

This integrated circuit can be damaged by ESD. Burr-Brown recommends that all integrated circuits be handled with appropriate precautions. Failure to observe proper handling and installation procedures can cause damage.

ESD damage can range from subtle performance degradation to complete device failure. Precision integrated circuits may be more susceptible to damage because very small parametric changes could cause the device not to meet its published specifications.

PACKAGE INFORMATION

PRODUCT	PACKAGE	PACKAGE DRAWING NUMBER ⁽¹⁾
INA116PA	16-Pin Plastic DIP	180
INA116P	16-Pin Plastic DIP	180
INA116UA	SOL-16 Surface-Mount	211
INA116U	SOL-16 Surface-Mount	211

NOTE: (1) For detailed drawing and dimension table, please see end of data sheet, or Appendix C of Burr-Brown IC Data Book.

The information provided herein is believed to be reliable; however, BURR-BROWN assumes no responsibility for inaccuracies or omissions. BURR-BROWN assumes no responsibility for the use of this information, and all use of such information shall be entirely at the user's own risk. Prices and specifications are subject to change without notice. No patent rights or licenses to any of the circuits described herein are implied or granted to any third party. BURR-BROWN does not authorize or warrant any BURR-BROWN product for use in life support devices and/or systems.

TYPICAL PERFORMANCE CURVES

At $T_A = +25^\circ\text{C}$, $V_S = \pm 15\text{V}$, $R_L = 10\text{k}\Omega$, unless otherwise noted.

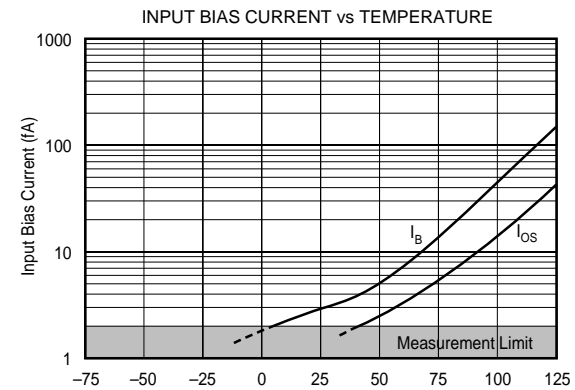
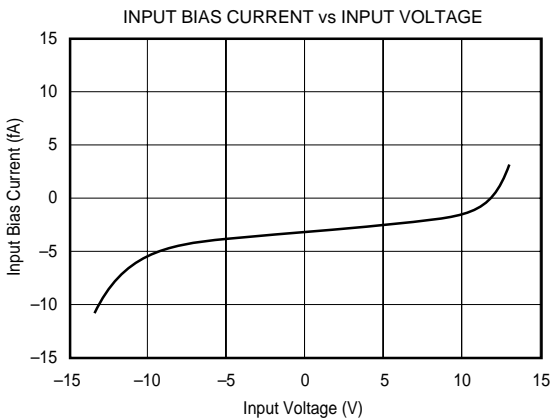
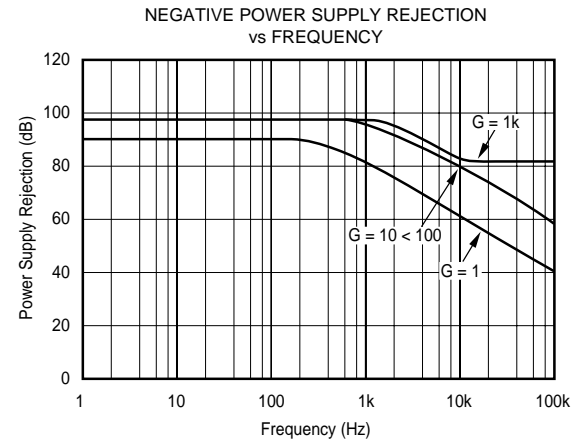
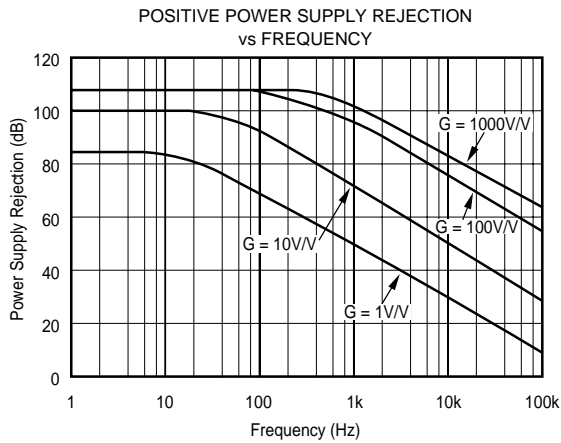
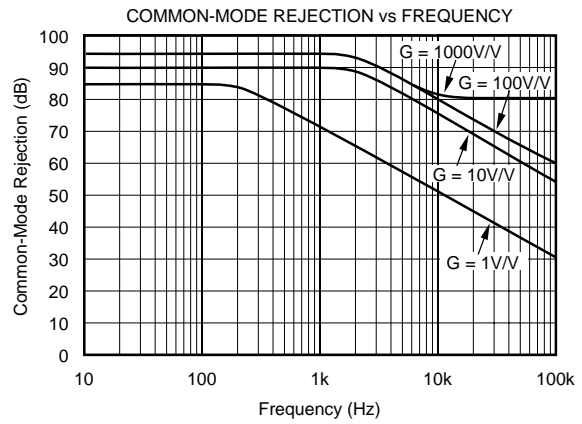
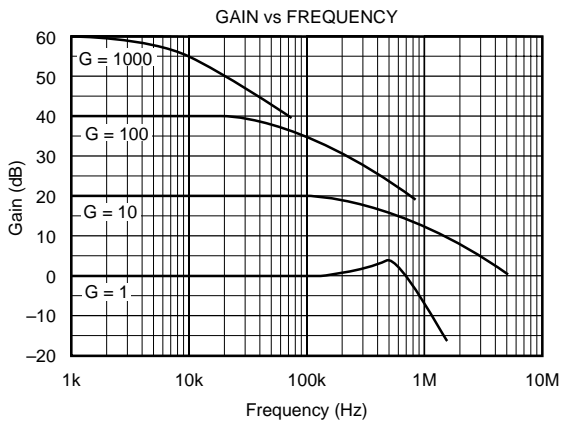

TYPICAL PERFORMANCE CURVES (CONT)

At $T_A = +25^\circ\text{C}$, $V_S = \pm 15\text{V}$, $R_L = 10\text{k}\Omega$, unless otherwise noted.

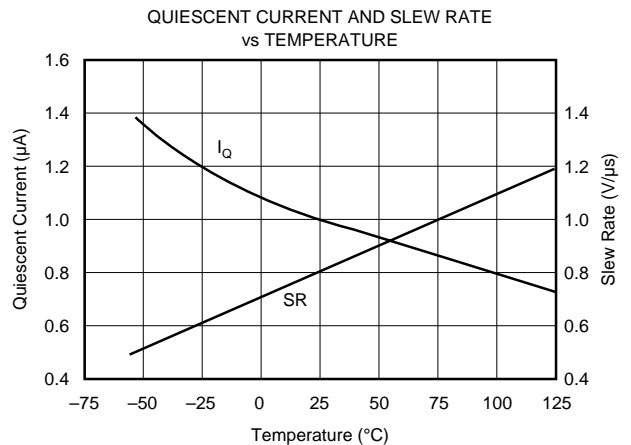
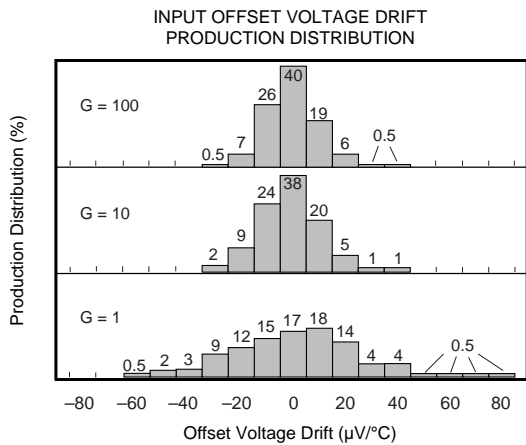
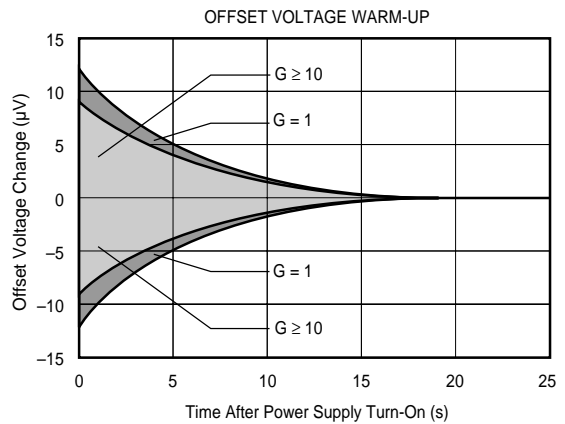
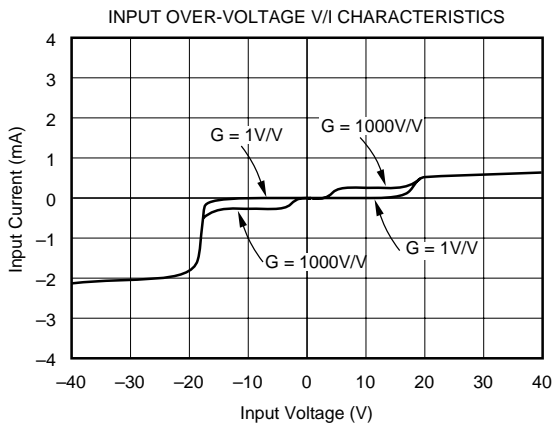
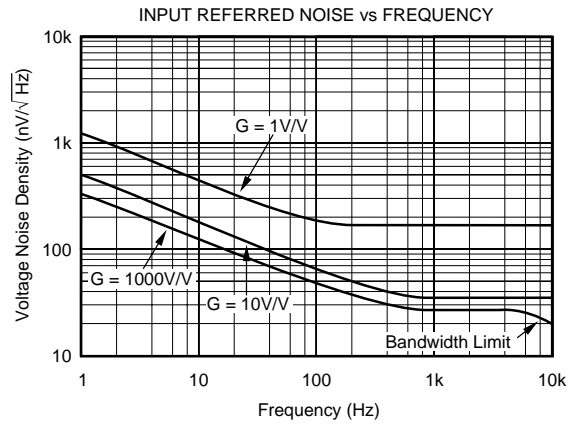
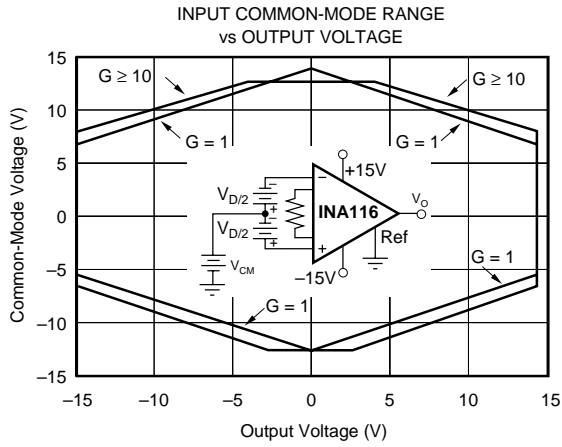

TYPICAL PERFORMANCE CURVES (CONT)

At $T_A = +25^\circ\text{C}$, $V_S = \pm 15\text{V}$, $R_L = 10\text{k}\Omega$, unless otherwise noted.

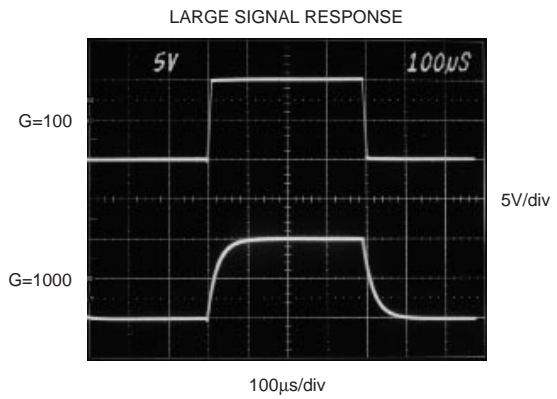
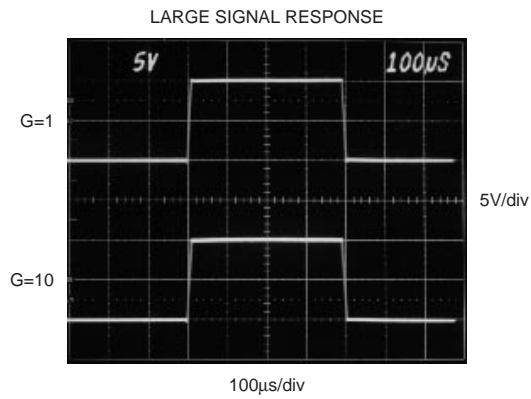
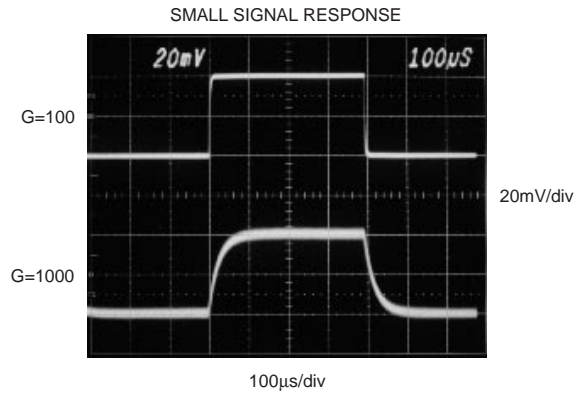
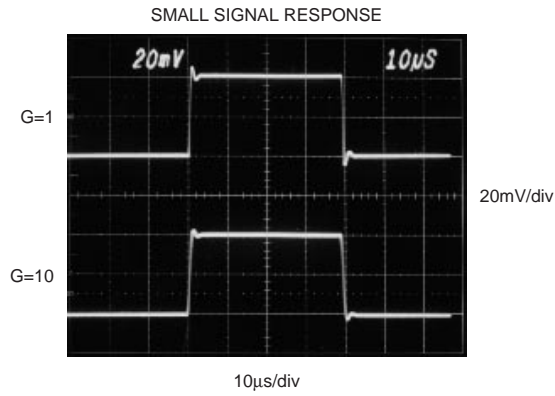
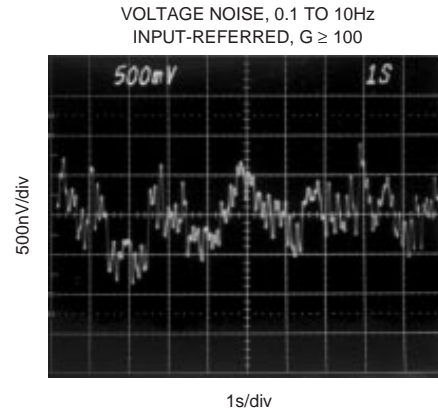
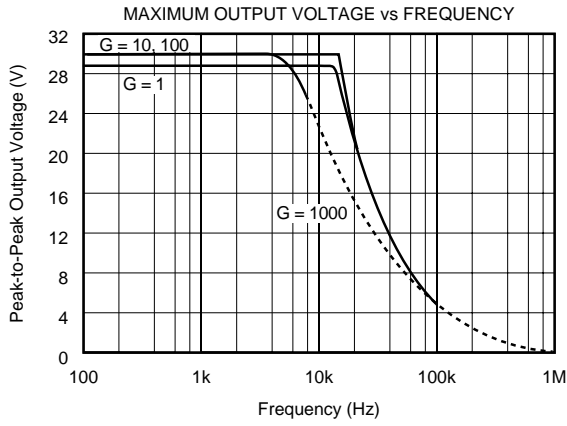

APPLICATIONS INFORMATION

Figure 1 shows the connections required for basic operation of the INA116. Applications with noisy or high impedance power supplies may require decoupling capacitors close to the supply pins as shown.

The output is referred to the output reference (Ref) terminal which is normally grounded. This must be a low impedance connection to assure good common-mode rejection. A resistance of 30Ω in series with this connection will cause a typical device to degrade to approximately 72dB CMR at G = 1.

SETTING THE GAIN

Gain of the INA116 is set by connecting a single external resistor, R_G, as shown. The gain is—

$$G = 1 + \frac{50k\Omega}{R_G} \quad (1)$$

Commonly used gains and resistor values are shown in Figure 1.

The 50kΩ term in equation 1 is the sum of the two feedback resistors of A₁ and A₂. These on-chip metal film resistors are laser trimmed to accurate absolute values. The accuracy and temperature coefficient of these resistors are included in the gain accuracy and drift specifications of the INA116.

The stability and temperature drift of R_G also affect gain. R_G's contribution to gain accuracy and drift can be directly inferred from the gain equation (1). Low resistor values required for high gain make wiring resistance important. Sockets add to the wiring resistance that will contribute additional gain error in gains of approximately 100 or greater.

OFFSET TRIMMING

The INA116 is laser trimmed for low offset voltage and offset voltage drift; most applications require no external offset adjustment. Figure 2 shows an optional circuit for trimming the output offset voltage. A voltage applied to the Ref terminal is summed at the output. Op amp A₁ provides a low source impedance for the Ref terminal, assuring good common-mode rejection.

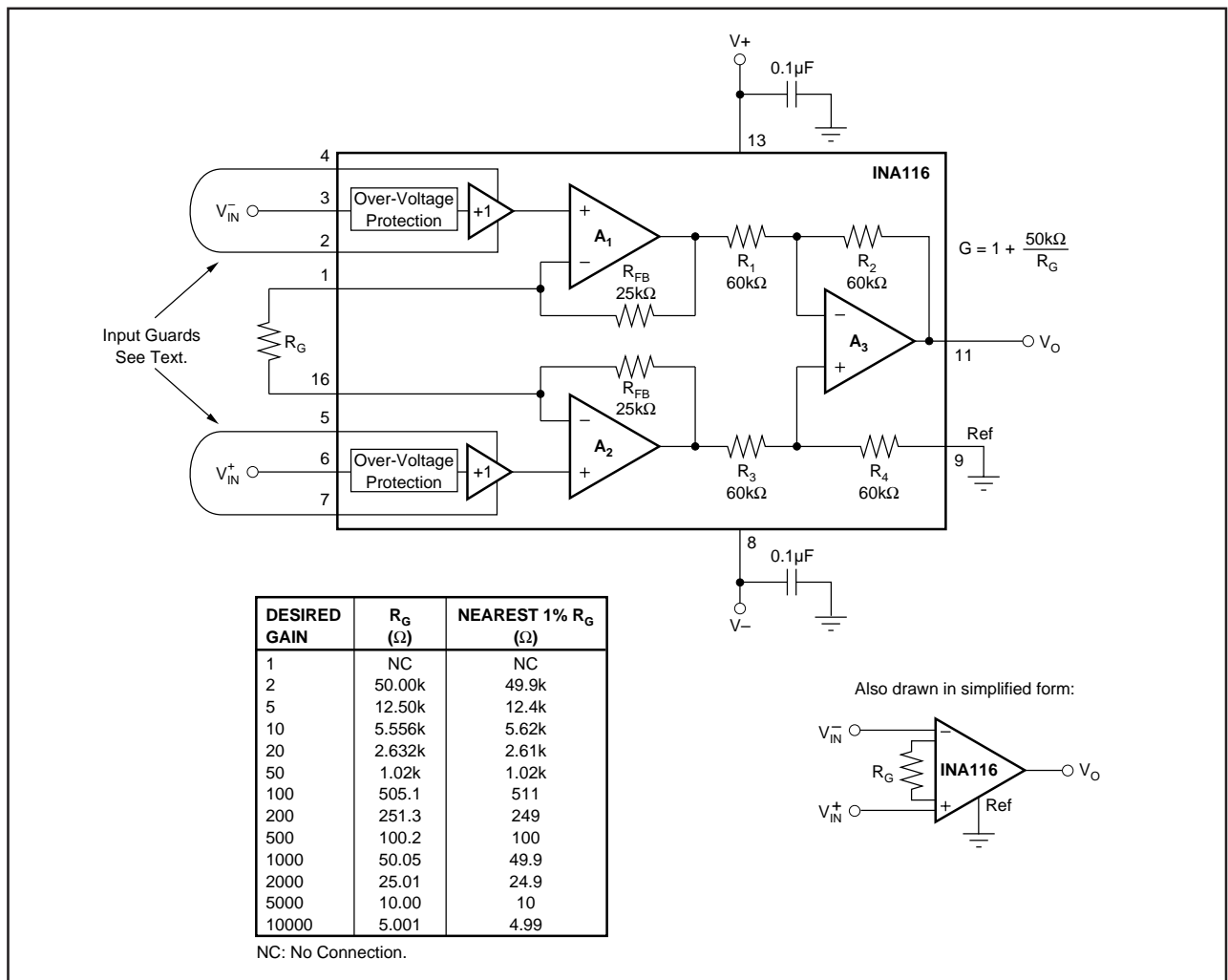

FIGURE 1. Basic Connections.

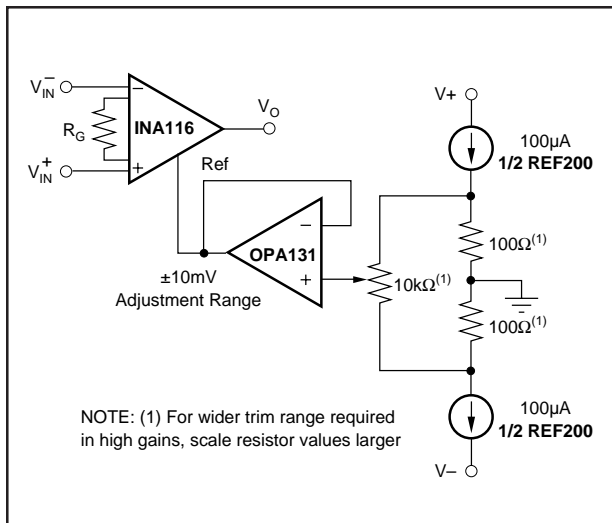

FIGURE 2. Optional Trimming of Output Offset Voltage.

INPUT BIAS CURRENT RETURN PATH

Input circuitry must provide an input bias current path for proper operation. Figure 3 shows resistors R_1 and R_2 to provide an input current path. Without these resistors, the inputs would eventually float to a potential that exceeds the common-mode range of the INA116 and the input amplifiers would saturate. Because of its exceedingly low input bias current, improperly biased inputs may operate normally for a period of time after power is first applied, or operate intermittently.

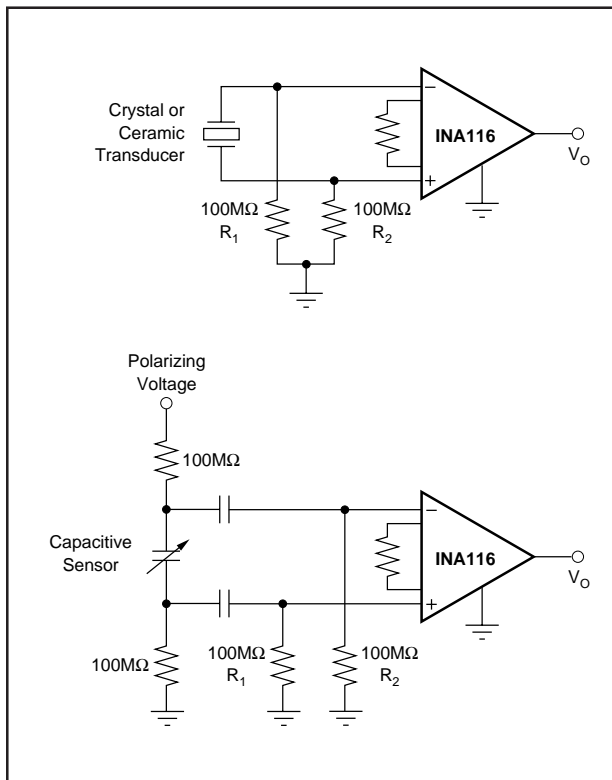

FIGURE 3. Providing An Input Bias Current Path.

CIRCUIT BOARD LAYOUT AND ASSEMBLY

Careful circuit board layout and assembly techniques are required to achieve the exceptionally low input bias current performance of the INA116. Guard terminals adjacent to both inputs make it easy to properly guard the critical input terminal layout. Since traces are not required to run between device pins, this layout is easily accomplished, even with the surface mount package. The guards should completely encircle their respective input connections—see Figure 4. Both sides of the circuit board should be guarded, even if only one side has an input terminal conductor. Route any time-varying signals away from the input terminals. Solder mask should not cover the input and guard traces since this can increase leakage.

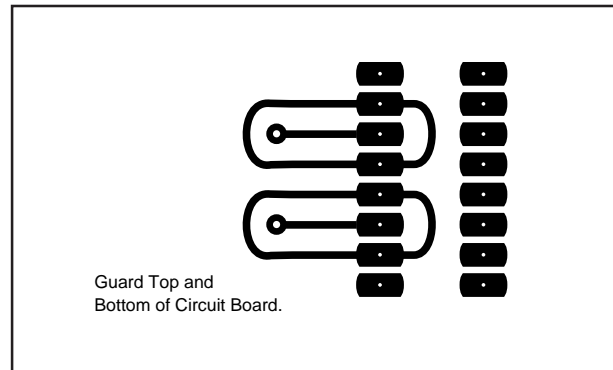

FIGURE 4. Circuit Board Guard Layout.

After assembly, the circuit board should be cleaned. Commercial solvents should be chosen according to the soldering method and flux used. Solvents should be cleaned and replaced often. Solvent cleaning should be followed by a de-ionized water rinse and 85°C bake out.

Sockets can be used, but select and evaluate them carefully for best results. Use caution when installing the INA116 in a socket. Careless handling can contaminate the plastic near the input pins, dramatically increasing leakage current.

A proven low leakage current assembly method is to bend the input pins outward so they do not contact the circuit board. Input connections are made in air and soldered directly to the input pin. This technique is often not practical or production-worthy. It is, however, a useful technique for evaluation and testing and provides a benchmark with which to compare other wiring techniques. The circuit board guarding techniques discussed normally reduce leakage to acceptable levels.

A solid mechanical assembly is required for good results. Nearby plastic parts can be especially troublesome since a static charge can develop and the slightest motion or vibration will couple charge to the inputs. Place a Faraday shield around the whole amplifier and input connection assembly to eliminate stray fields.

INPUT CONNECTIONS

Some applications must make high impedance input connections to external sensors or input connectors. To assure low leakage, the input should be guarded all the way to the signal source—see Figure 5. Coaxial cable can be used with the shield driven by the guard. A separate connection is required to provide a ground reference at the signal source. Triaxial cable may reduce noise pickup and provides the ground reference at the source. Drive the inner shield at guard

potential and ground the outer shield. Two separate guarded lines are required if both the inverting and non-inverting inputs are brought to the source.

The guard drive output current is limited to approximately $+2\text{mA}/-50\mu\text{A}$. For slow input signals the internal guard output can directly drive a cable shield. With fast input signals, however, the guard may not provide sufficient output current to rapidly charge the cable capacitance. An op amp buffer may be required as shown in Figure 6.

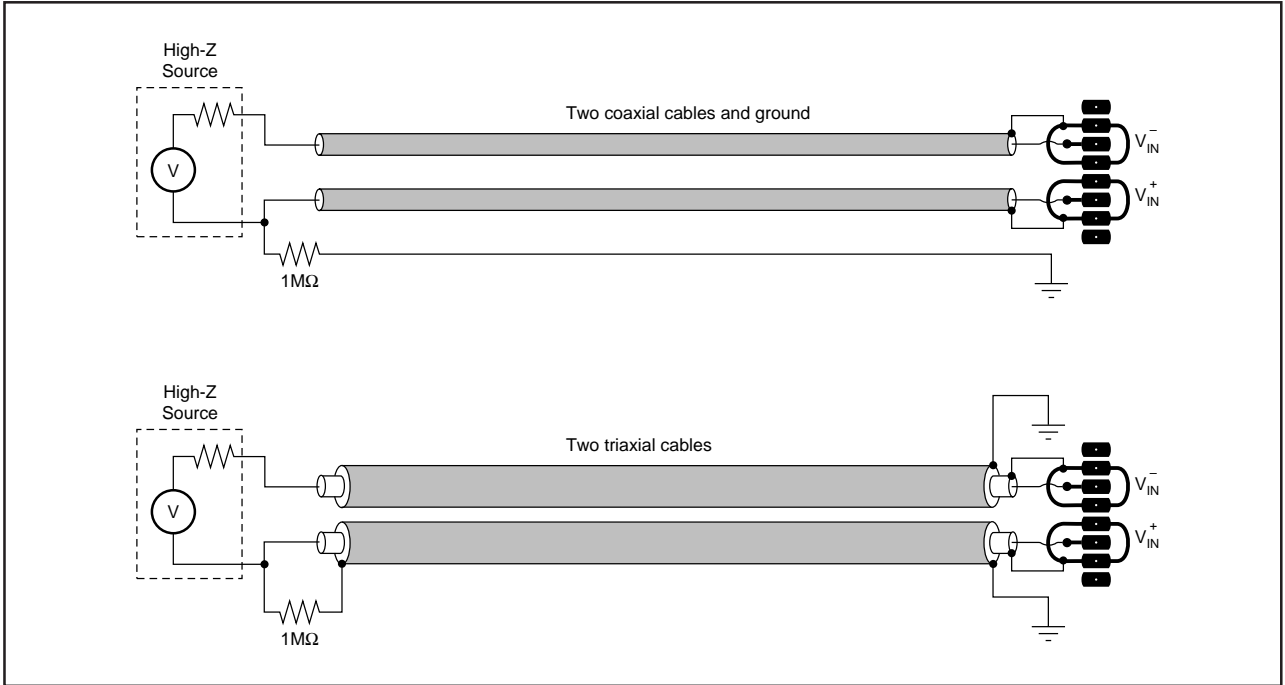

FIGURE 5. Input Cable Guarding Circuits.

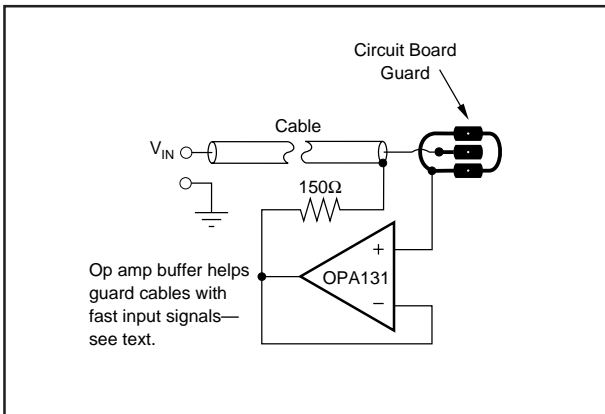

FIGURE 6. Buffered Guard Drive.

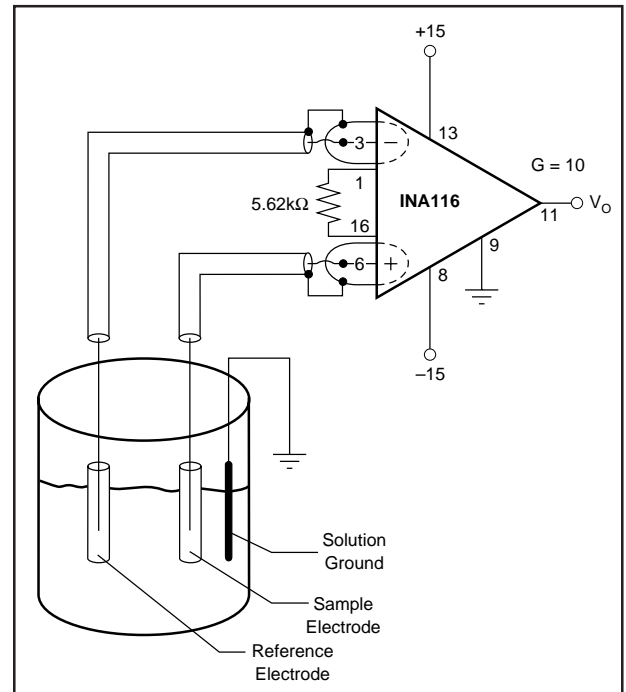

FIGURE 7. pH or Ion Measurement System.

PACKAGING INFORMATION

Orderable Device	Status (1)	Package Type	Package Drawing	Pins	Package Qty	Eco Plan (2)	Lead finish/ Ball material (6)	MSL Peak Temp (3)	Op Temp (°C)	Device Marking (4/5)	Samples
INA116PA	NRND	PDIP	N	16	25	RoHS & Green	NIPDAU	N / A for Pkg Type	-40 to 85	INA116PA	
INA116UA	NRND	SOIC	DW	16	40	RoHS & Green	NIPDAU-DCC	Level-3-260C-168 HR		INA116UA	
INA116UAG4	NRND	SOIC	DW	16	40	RoHS & Green	NIPDAU-DCC	Level-3-260C-168 HR		INA116UA	

(1) The marketing status values are defined as follows:

ACTIVE: Product device recommended for new designs.

LIFEBUY: TI has announced that the device will be discontinued, and a lifetime-buy period is in effect.

NRND: Not recommended for new designs. Device is in production to support existing customers, but TI does not recommend using this part in a new design.

PREVIEW: Device has been announced but is not in production. Samples may or may not be available.

OBsolete: TI has discontinued the production of the device.

(2) **RoHS:** TI defines "RoHS" to mean semiconductor products that are compliant with the current EU RoHS requirements for all 10 RoHS substances, including the requirement that RoHS substance do not exceed 0.1% by weight in homogeneous materials. Where designed to be soldered at high temperatures, "RoHS" products are suitable for use in specified lead-free processes. TI may reference these types of products as "Pb-Free".

RoHS Exempt: TI defines "RoHS Exempt" to mean products that contain lead but are compliant with EU RoHS pursuant to a specific EU RoHS exemption.

Green: TI defines "Green" to mean the content of Chlorine (Cl) and Bromine (Br) based flame retardants meet JS709B low halogen requirements of <=1000ppm threshold. Antimony trioxide based flame retardants must also meet the <=1000ppm threshold requirement.

(3) MSL, Peak Temp. - The Moisture Sensitivity Level rating according to the JEDEC industry standard classifications, and peak solder temperature.

(4) There may be additional marking, which relates to the logo, the lot trace code information, or the environmental category on the device.

(5) Multiple Device Markings will be inside parentheses. Only one Device Marking contained in parentheses and separated by a "~" will appear on a device. If a line is indented then it is a continuation of the previous line and the two combined represent the entire Device Marking for that device.

(6) Lead finish/Ball material - Orderable Devices may have multiple material finish options. Finish options are separated by a vertical ruled line. Lead finish/Ball material values may wrap to two lines if the finish value exceeds the maximum column width.

Important Information and Disclaimer:The information provided on this page represents TI's knowledge and belief as of the date that it is provided. TI bases its knowledge and belief on information provided by third parties, and makes no representation or warranty as to the accuracy of such information. Efforts are underway to better integrate information from third parties. TI has taken and continues to take reasonable steps to provide representative and accurate information but may not have conducted destructive testing or chemical analysis on incoming materials and chemicals. TI and TI suppliers consider certain information to be proprietary, and thus CAS numbers and other limited information may not be available for release.

In no event shall TI's liability arising out of such information exceed the total purchase price of the TI part(s) at issue in this document sold by TI to Customer on an annual basis.

TUBE

*All dimensions are nominal

Device	Package Name	Package Type	Pins	SPQ	L (mm)	W (mm)	T (μm)	B (mm)
INA116PA	N	PDIP	16	25	506	13.97	11230	4.32
INA116UA	DW	SOIC	16	40	507	12.83	5080	6.6
INA116UAG4	DW	SOIC	16	40	507	12.83	5080	6.6

IMPORTANT NOTICE AND DISCLAIMER

TI PROVIDES TECHNICAL AND RELIABILITY DATA (INCLUDING DATA SHEETS), DESIGN RESOURCES (INCLUDING REFERENCE DESIGNS), APPLICATION OR OTHER DESIGN ADVICE, WEB TOOLS, SAFETY INFORMATION, AND OTHER RESOURCES "AS IS" AND WITH ALL FAULTS, AND DISCLAIMS ALL WARRANTIES, EXPRESS AND IMPLIED, INCLUDING WITHOUT LIMITATION ANY IMPLIED WARRANTIES OF MERCHANTABILITY, FITNESS FOR A PARTICULAR PURPOSE OR NON-INFRINGEMENT OF THIRD PARTY INTELLECTUAL PROPERTY RIGHTS.

These resources are intended for skilled developers designing with TI products. You are solely responsible for (1) selecting the appropriate TI products for your application, (2) designing, validating and testing your application, and (3) ensuring your application meets applicable standards, and any other safety, security, regulatory or other requirements.

These resources are subject to change without notice. TI grants you permission to use these resources only for development of an application that uses the TI products described in the resource. Other reproduction and display of these resources is prohibited. No license is granted to any other TI intellectual property right or to any third party intellectual property right. TI disclaims responsibility for, and you will fully indemnify TI and its representatives against, any claims, damages, costs, losses, and liabilities arising out of your use of these resources.

TI's products are provided subject to [TI's Terms of Sale](#) or other applicable terms available either on ti.com or provided in conjunction with such TI products. TI's provision of these resources does not expand or otherwise alter TI's applicable warranties or warranty disclaimers for TI products.

TI objects to and rejects any additional or different terms you may have proposed.

Mailing Address: Texas Instruments, Post Office Box 655303, Dallas, Texas 75265
Copyright © 2022, Texas Instruments Incorporated

Looking for pricing, stock, or lifecycle information?

Click below to explore more details on WIN SOURCE:

 [View INA116UA](#) on WIN SOURCE

 [Texas Instruments](#) Information

Optimize Your Supply Chain with WIN SOURCE Solutions

-  Global Sourcing Solution
-  Obsolete Management
-  Cost Control Management
-  Shortage Management
-  Alternative Solution
-  Excess Inventory Management