



**THE DATASHEET OF
INA117KU/2K5**



INA117 High Common-Mode Voltage Difference Amplifier

1 Features

- Common-mode input range: $\pm 200V$ ($V_S = \pm 15V$)
- Protected inputs:
 - $\pm 500V$ Common-mode
 - $\pm 500V$ Differential
- Unity gain: 0.05% gain error maximum
- Nonlinearity: 0.001% maximum
- CMRR: 70dB minimum

2 Applications

- [Single multi axis servo drives](#)
- [Industrial machine and machine tools](#)
- [Semiconductor test and ATE](#)
- [Ultrasound scanner](#)

3 Description

The INA117 is a precision unity-gain difference amplifier with very high common-mode input voltage range. The INA117 is a single monolithic IC consisting of a precision op amp and integrated thin-film resistor network. The device can accurately measure small differential voltages in the presence of common-

mode signals up to $\pm 200V$. The INA117 inputs are protected from momentary common-mode or differential overloads up to $\pm 500V$.

In many applications, where galvanic isolation is not essential, the INA117 can replace isolation amplifiers. This design can eliminate costly isolated input-side power supplies and the associated ripple, noise, and quiescent current. The 0.001% nonlinearity and 200kHz bandwidth of the INA117 is superior to those of conventional isolation amplifiers.

The INA117 is available in 8-pin plastic mini-DIP and SO-8 surface-mount packages, specified for the $-40^{\circ}C$ to $85^{\circ}C$ temperature range.

Package Information

PART NUMBER	PACKAGE ⁽¹⁾	PACKAGE SIZE ⁽²⁾
INA117P	P (DIP, 8)	6.35mm × 9.81mm
INA117KU	D (SOIC, 8)	3.91mm × 4.9mm
INA117KU/2K5		

(1) For more information, see [Section 10](#).

(2) The package size (length × width) is a nominal value and includes pins, where applicable.

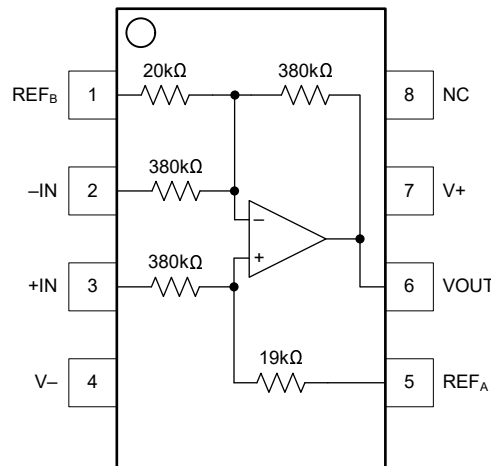

INA117 D Package Top View



Table of Contents

1 Features	1	7.1 Application Information.....	7
2 Applications	1	8 Device and Documentation Support	17
3 Description	1	8.1 Documentation Support.....	17
4 Pin Configuration and Functions	2	8.2 Receiving Notification of Documentation Updates....	17
5 Specifications	3	8.3 Support Resources.....	17
5.1 Absolute Maximum Ratings.....	3	8.4 Trademarks.....	17
5.2 ESD Ratings	3	8.5 Electrostatic Discharge Caution.....	17
5.3 Recommended Operating Conditions.....	3	8.6 Glossary.....	17
5.4 Thermal Information.....	3	9 Revision History	18
5.5 Electrical Characteristics.....	4	10 Mechanical, Packaging, and Orderable Information	18
6 Typical Characteristics	5		
7 Application and Implementation	7		

4 Pin Configuration and Functions

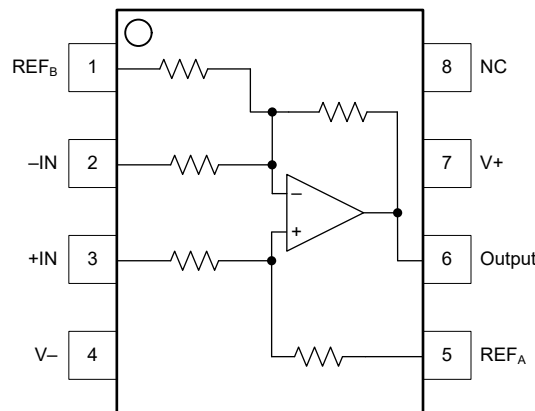

**Figure 4-1. DIP/SO
INA117P, KU
Top View**

Table 4-1. Pin Functions

PIN		TYPE ⁽¹⁾	DESCRIPTION
NAME	NO.		
-In	2	I	Inverting input.
+In	3	I	Non-inverting input.
NC	8	—	No internal connection. Can be grounded or disconnected.
Output	6	O	Output of the amplifier.
Ref _A	5	I	Reference A.
Ref _B	1	I	Reference B.
V-	4	P	Negative power supply.
V+	7	P	Positive power supply.

(1) I = Input, O = Output, I/O = Input or Output, G = Ground, P = Power.

5 Specifications

5.1 Absolute Maximum Ratings

over operating free-air temperature range (unless otherwise noted)⁽¹⁾

			MIN	MAX	UNIT
V _S		Dual supply, V _S = (V+) – (V–)		±22	V
	Signal input pins	Continuous		±200	V
		Peak (0.1s)		±500	V
	Output short-circuit ⁽²⁾		Continuous		
T _A	Operating temperature		–40	85	°C
T _{stg}	Storage temperature		–55	125	°C
	Junction temperature			150	°C
	Lead temperature (soldering, 10s)			300	°C

- (1) Operation outside the Absolute Maximum Ratings may cause permanent device damage. Absolute Maximum Ratings do not imply functional operation of the device at these or any other conditions beyond those listed under Recommended Operating Conditions. If used outside the Recommended Operating Conditions but within the Absolute Maximum Ratings, the device may not be fully functional, and this may affect device reliability, functionality, performance, and shorten the device lifetime.
- (2) Short-circuit to V_S / 2.

5.2 ESD Ratings

			VALUE	UNIT
V _(ESD)	Electrostatic discharge	Human-body model (HBM), per ANSI/ESDA/JEDEC JS-001 ⁽¹⁾	±1500	V
		Charged-device model (CDM), per JEDEC specification JESD22-C101 ⁽²⁾	±1000	

- (1) JEDEC document JEP155 states that 500V HBM allows safe manufacturing with a standard ESD control process.
- (2) JEDEC document JEP157 states that 250V CDM allows safe manufacturing with a standard ESD control process.

5.3 Recommended Operating Conditions

over operating free-air temperature range (unless otherwise noted)

			MIN	TYP	MAX	UNIT
V _S	Supply voltage	Single-supply	10	30	36	V
		Dual-supply	±5	±15	±18	
T _A	Specified temperature		–40		85	°C

5.4 Thermal Information

THERMAL METRIC ⁽¹⁾		INA117	INA117	UNIT
		D (SOIC)	P (PDIP)	
		8 PINS	8 PINS	
θ _{JA}	Junction-to-ambient thermal resistance	150	80	°C/W

- (1) For more information about traditional and new thermal metrics, see the [Semiconductor and IC Package Thermal Metrics](#) application note.

5.5 Electrical Characteristics

at $T_A = 25^\circ\text{C}$, $V_S = \pm 15\text{V}$, $R_L = 10\text{k}\Omega$, $V_{\text{REF}} = 0\text{V}$, $V_{\text{CM}} = V_S/2$, and $G = 1$ (unless otherwise noted)

PARAMETER		TEST CONDITIONS		MIN	TYP	MAX	UNIT
INPUT							
V_{OS}	Offset voltage	RTO (P package)			120	1000	μV
		RTO (KU package)			600	2000	μV
	Offset voltage drift	RTO, $T_A = -40^\circ\text{C}$ to 85°C			8.5		$\mu\text{V}/^\circ\text{C}$
	Long term drift				200		$\mu\text{V}/\text{mo}$
PSRR	Power-supply rejection ratio	RTO, $V_S = \pm 5\text{V}$ to $\pm 18\text{V}$		74	90		dB
	Common-mode voltage ⁽¹⁾			-200		200	V
	Differential voltage			-10		10	V
CMRR	Common-mode voltage rejection	DC, $V_{\text{CM}} = -200\text{V}$ to 200V	$T_A = -40^\circ\text{C}$ to 85°C	70	80		dB
			$T_A = -40^\circ\text{C}$ to 85°C		75		
		AC, 60Hz, $V_{\text{CM}} = -200\text{V}$ to 200V	66	80			
	Differential input impedance				800		k Ω
	Common-mode input impedance				200		
NOISE							
e_{N}	Voltage noise	RTO, $f_{\text{B}} = 0.1\text{Hz}$ to 10Hz			25		μV_{PP}
		RTO, $f = 1\text{kHz}$			550		$\text{nV}/\sqrt{\text{Hz}}$
GAIN							
GE	Gain error				± 0.01	± 0.05	%
	Gain error drift	$T_A = -40^\circ\text{C}$ to 85°C			± 2		$\text{ppm}/^\circ\text{C}$
	Gain nonlinearity ⁽²⁾				± 0.0005	± 0.001	% of FSR
OUTPUT							
	Output voltage	$I_{\text{O}} = 20\text{mA}$, -5mA		10	12		V
	Output impedance				0.01		Ω
C_{L}	Load capacitance	Stable operation			1		nF
	Short-circuit current	Continuous to $V_S/2$			49, -13		mA
FREQUENCY RESPONSE							
BW	Bandwidth, -3dB				200		kHz
	Full power bandwidth	$V_{\text{O}} = 20\text{V}_{\text{PP}}$		30			kHz
SR	Slew rate			1.7	2.6		$\text{V}/\mu\text{s}$
t_{s}	Settling time	To 0.1%,	$V_{\text{O}} = 10\text{V}$ step		6.5		μs
			$V_{\text{O}} = 10\text{V}$ step		10		
		To 0.01%	$V_{\text{CM}} = 10\text{V}$ step, $V_{\text{DIFF}} = 0\text{V}$		4.5		
POWER SUPPLY							
I_{Q}	Quiescent current	$V_{\text{IN}} = 0\text{V}$			1.5	± 2	mA

(1) Input common-mode voltage varies with output voltage; see *Typical Characteristics*.

(2) Specified by wafer test.

6 Typical Characteristics

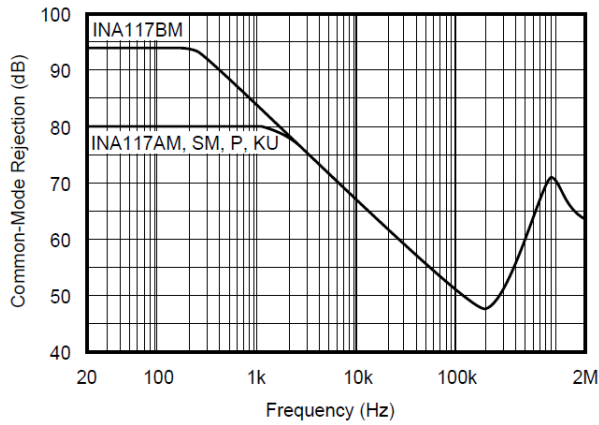

Figure 6-1. Common-mode Rejection vs Frequency

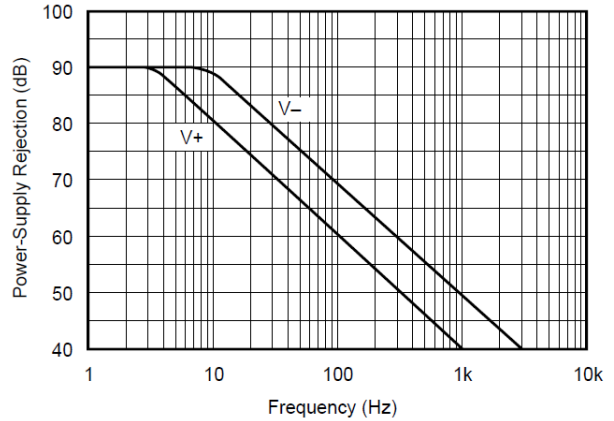

Figure 6-2. Power-supply Rejection vs Frequency

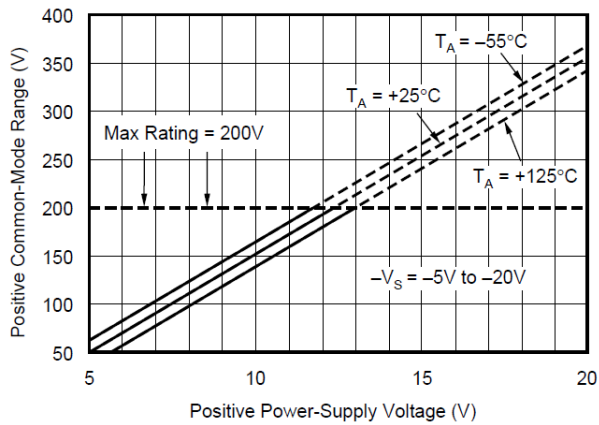

Figure 6-3. Positive Common-mode Voltage Range vs Positive Power-supply Voltage

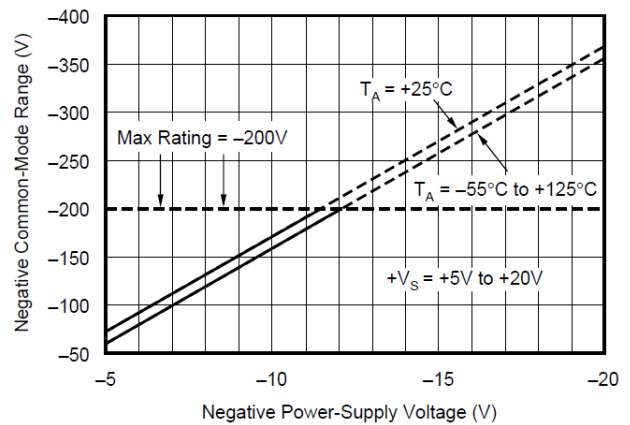

Figure 6-4. Negative Common-mode Voltage Range vs Negative Power-supply Voltage

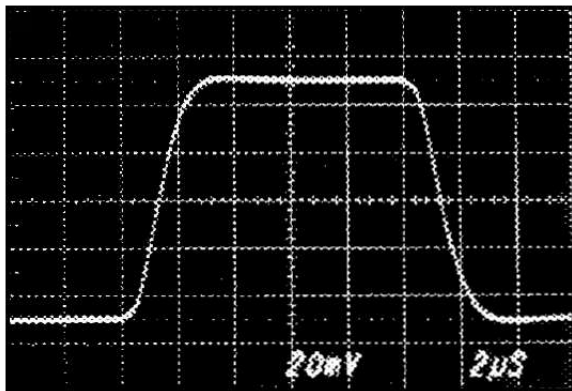

Figure 6-5. Small Signal Step Response $C_L = 0\text{pF}$

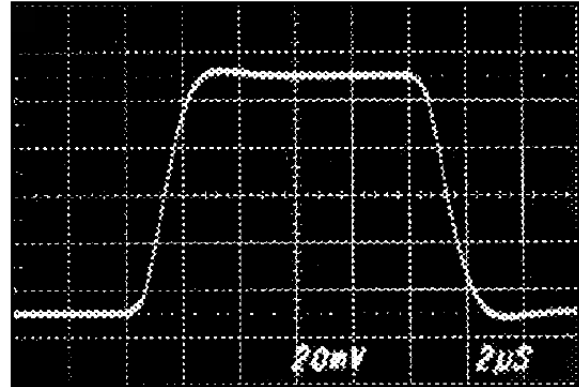

Figure 6-6. Small Signal Step Response $C_L = 1000\text{pF}$

6 Typical Characteristics (continued)

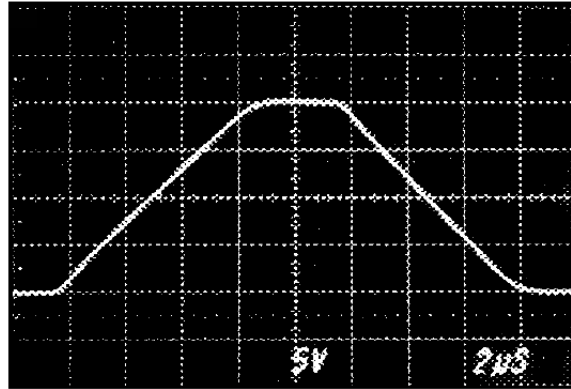

Figure 6-7. Large Signal Step Response

7 Application and Implementation

Note

Information in the following applications sections is not part of the TI component specification, and TI does not warrant its accuracy or completeness. TI's customers are responsible for determining suitability of components for their purposes, as well as validating and testing their design implementation to confirm system functionality.

7.1 Application Information

Figure 7-1 shows the basic connections required for operation.

Applications with noisy or high-impedance power-supply lines can require decoupling capacitors close to the device pins.

The output voltage is equal to the differential input voltage between pins 2 and 3. The common mode input voltage is rejected.

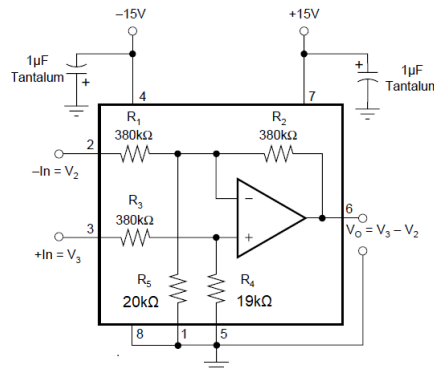

Figure 7-1. Basic Power and Signal Connections

7.1.1 Common-mode Rejection

Common-mode rejection (CMR) of the INA117 is dependent on the input resistor network, which is laser-trimmed for accurate ratio matching. To maintain high CMR, having low source impedances is important for driving the two inputs. A 75Ω resistance in series with pin 2 or 3 decreases CMR from 86dB to 72dB.

Resistance in series with the reference pins also degrades CMR. A 4Ω resistance in series with pin 1 or 5 decreases CMRR from 86dB to 72dB.

Most applications do not require trimming. Figure 7-2 and Figure 7-3 show optional circuits that can be used for trimming offset voltage and common-mode rejection.

7.1.2 Transfer Function

Most applications use the INA117 as a simple unity-gain difference amplifier. The transfer function is:

$$V_0 = V_3 - V_2$$

V_3 and V_2 are the voltages at pins 3 and 2.

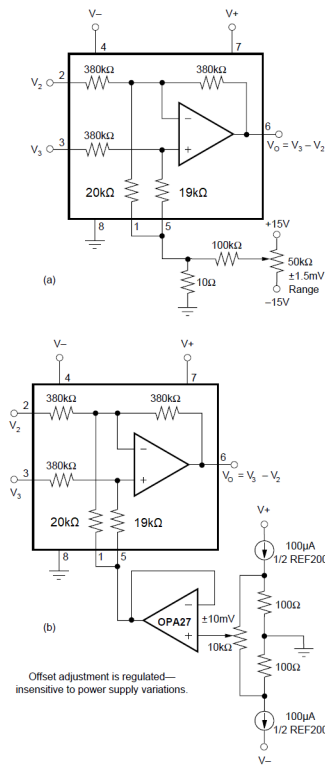

Figure 7-2. Offset Voltage Trim Circuits

Some applications, however, apply voltages to the reference terminals (pins 1 and 5). A more complete transfer function is:

$$V_0 = V_3 - V_2 + 19 \times V_5 - 18 \times V_1$$

V_5 and V_1 are the voltages at pins 5 and 1.

7.1.3 Measuring Current

The INA117 can be used to measure a current by sensing the voltage drop across a series resistor, R_S . [Figure 7-4](#) shows the INA117 used to measure the supply currents of a device under test. The circuit in [Figure 7-5](#) measures the output current of a power supply. If the power supply has a sense connection, the power supply can be connected to the output side of R_S to eliminate the voltage-drop error. Another common application is current-to-voltage conversion, as shown in [Figure 7-6](#).

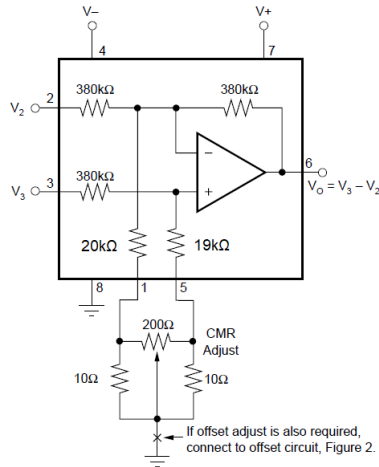

Figure 7-3. CMR Trim Circuit

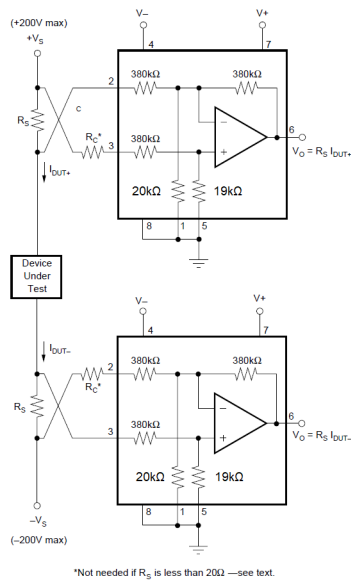

Figure 7-4. Measuring Supply Currents of Device Under Test

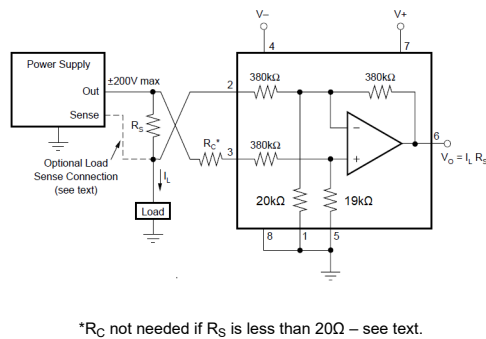

Figure 7-5. Measuring Power Supply Output Current

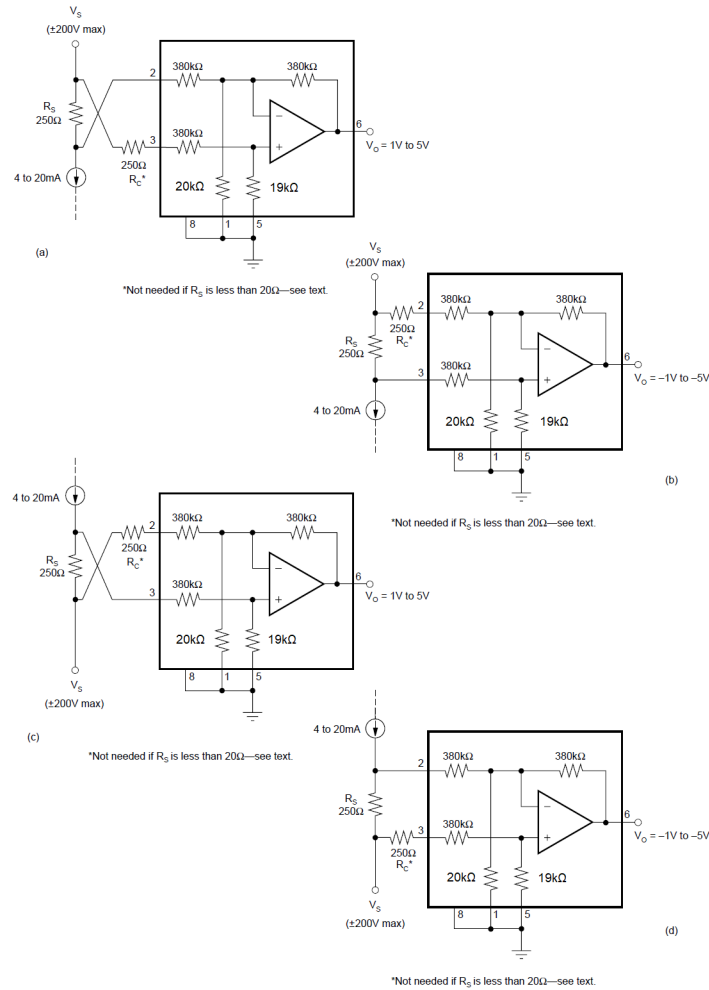

Figure 7-6. Current to Voltage Converter

In all cases, the sense resistor imbalances the input resistor matching of the INA117, degrading the CMR. Also, the input impedance of the INA117 loads R_S , causing gain error in the voltage-to-current conversion. Both of these errors can be easily corrected.

The CMR error can be corrected with the addition of a compensation resistor, R_C , equal in value to R_S as shown in [Figure 7-4](#), [Figure 7-5](#), and [Figure 7-6](#). If R_S is less than 20Ω, the degradation in CMR is negligible and R_C can be omitted. If R_S is larger than approximately 2kΩ, trimming R_C can be required to achieve greater than 86dB CMR. This trim is because the actual INA117 input impedances have 1% typical mismatch. If R_S is more than approximately 100Ω, the gain error is greater than the 0.05% specification of the INA117. This gain error can be corrected by slightly increasing the value of R_S . The corrected value, R_S' , can be calculated by:

$$R_S' = \frac{R_S \times 380\text{k}\Omega}{380\text{k}\Omega - R_S} \tag{1}$$

Example: For a 1V/mA transfer function, the nominal, uncorrected value for R_S is 1kΩ. A slightly larger value, $R_S' = 1002.6\Omega$, compensates for the gain error due to loading.

The 380kΩ term in the equation for R_S' has a tolerance of ±25%, so sense resistors above approximately 400Ω can require trimming to achieve gain accuracy better than 0.05%.

Of course, if a buffer amplifier is added as shown in [Figure 7-7](#), both inputs see a low source impedance, and the sense resistor is not loaded. As a result, there is no gain error or CMR degradation. The buffer amplifier

can operate as a unity gain buffer or as an amplifier with non-inverting gain. Gain added ahead of the INA117 improves both CMR and signal-to-noise. Added gain also allows a lower voltage drop across the sense resistor. The OPA1013 is a good choice for the buffer amplifier since both the input and output can swing close to the negative power supply.

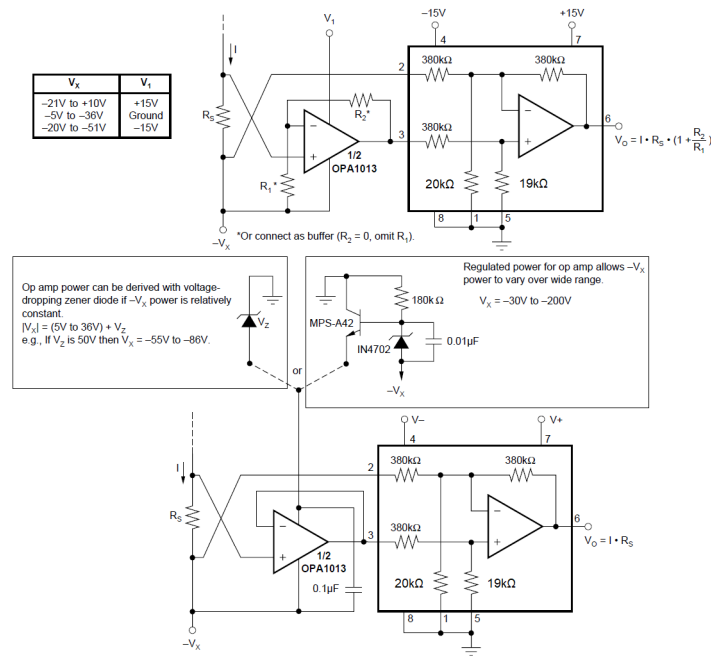

Figure 7-7. Current Sensing With Input Buffer

Figure 7-8 shows very high input impedance buffer used to measure low leakage currents. Here, the buffer operational amplifier is powered with an isolated, split-voltage power supply. Using an isolated power supply allows full $\pm 200V$ common-mode input range.

7.1.4 Noise Performance

The noise performance of the INA117 is dominated by the internal resistor network. The thermal or Johnson noise of these resistors produces approximately $550nV/\sqrt{Hz}$ noise. The internal op amp contributes virtually no excess noise at frequencies above 100Hz.

Many applications can be satisfied with less than the full 200kHz bandwidth of the INA117. In these cases, the noise can be reduced with a low-pass filter on the output. The two-pole filter shown in Figure 7-9 limits bandwidth to 1kHz and reduces noise by more than 15:1. Since the INA117 has a $1/f$ noise corner frequency of approximately 100Hz, a cutoff frequency below 100Hz does not further reduce noise.

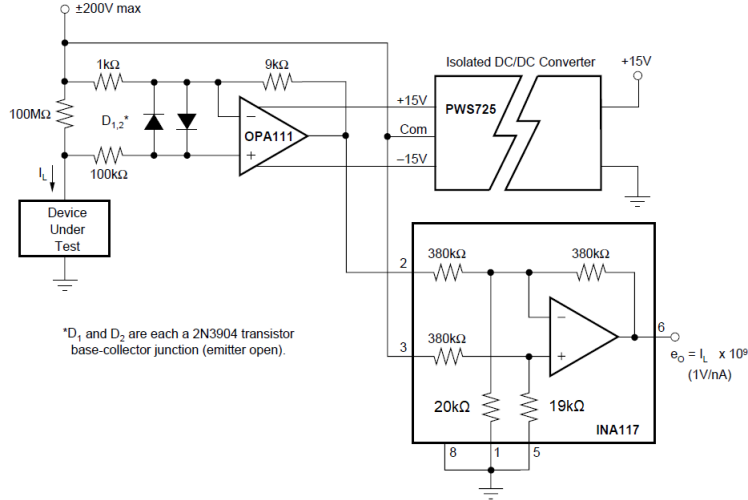
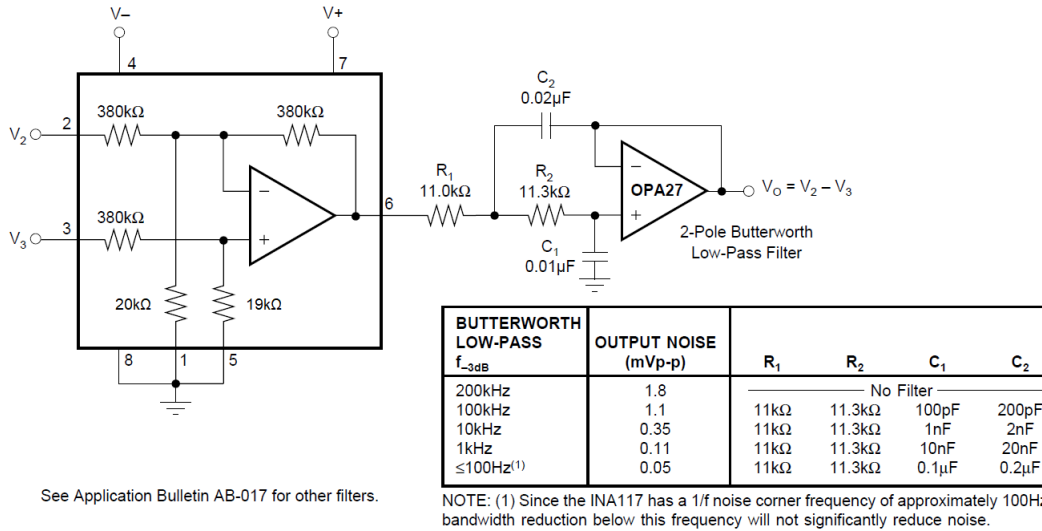

Figure 7-8. Leakage Current Measurement Circuit



See Application Bulletin AB-017 for other filters.

Figure 7-9. Output Filter for Noise Reduction

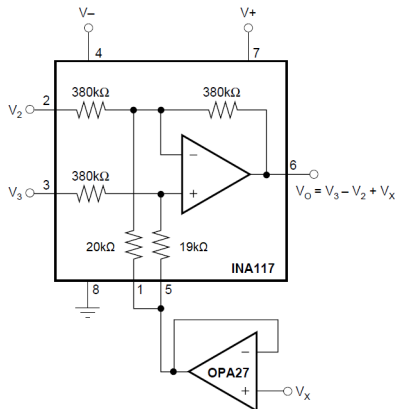

Figure 7-10. Summing V_x in Output

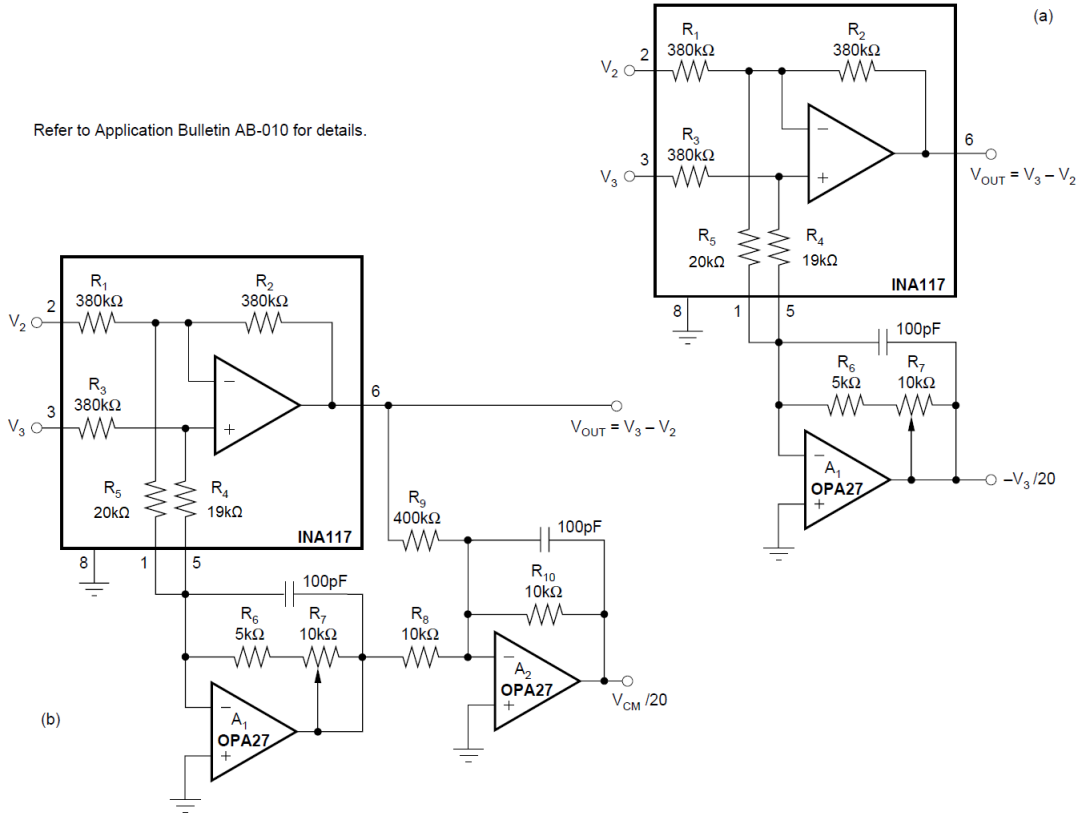

Figure 7-11. Common-mode Voltage Monitoring

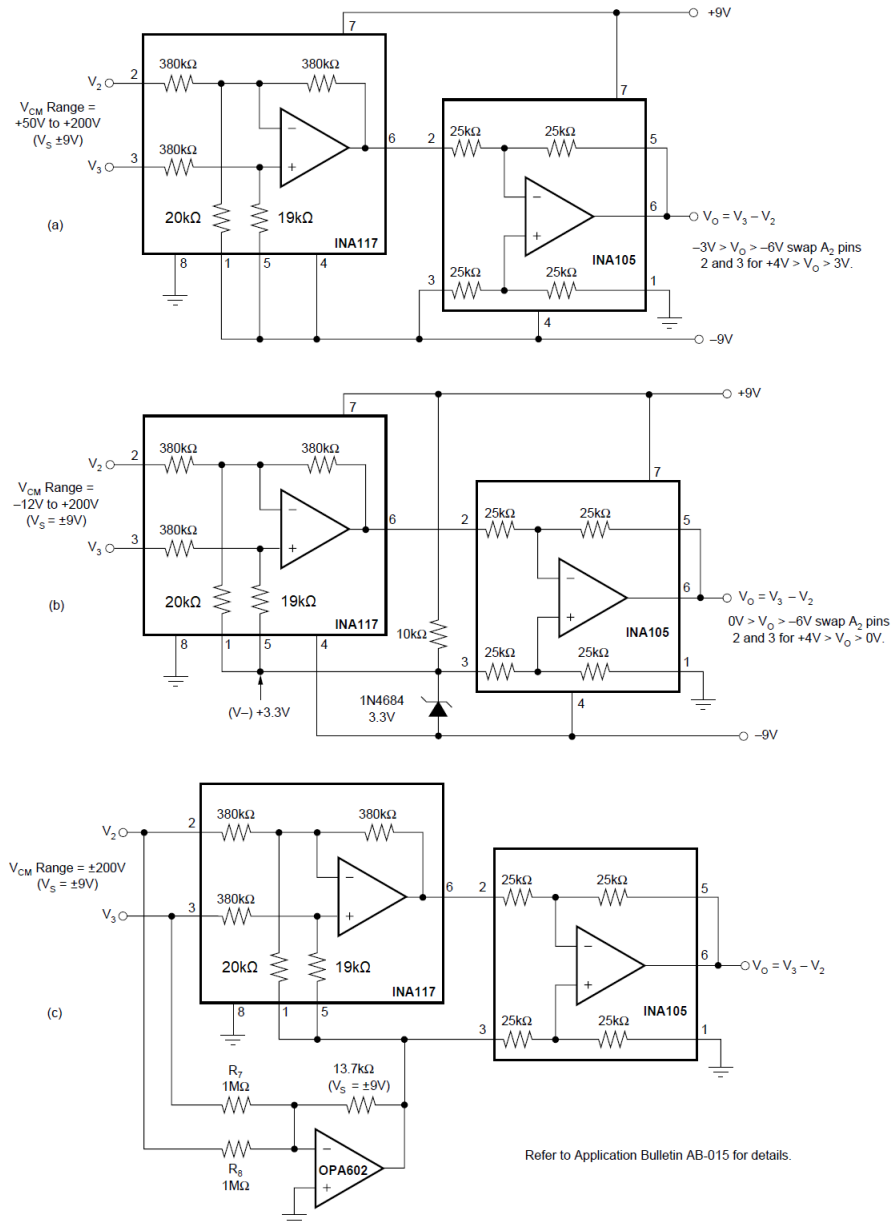

Figure 7-12. Offsetting or Boosting Common-mode Voltage Range for Reduced Power-supply Voltage Operation

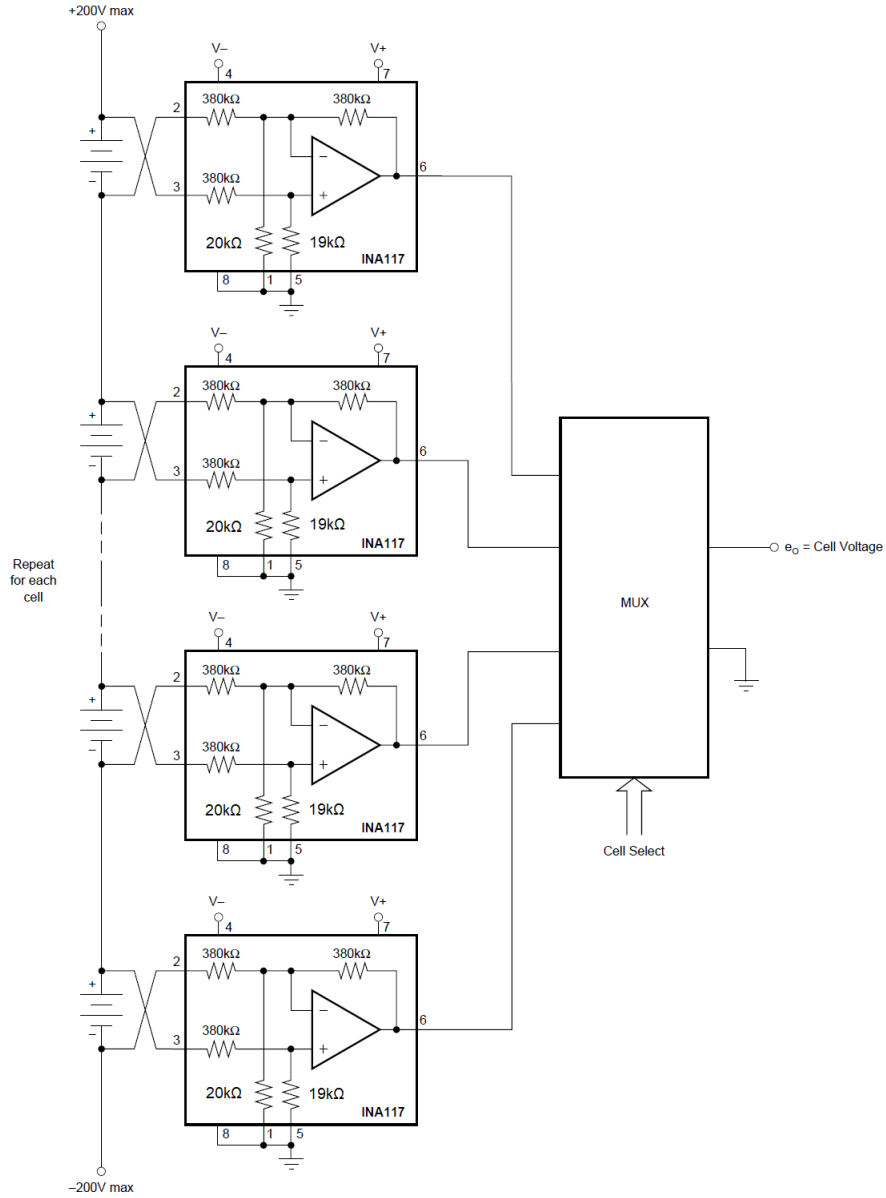

Figure 7-13. Battery Cell Voltage Monitor

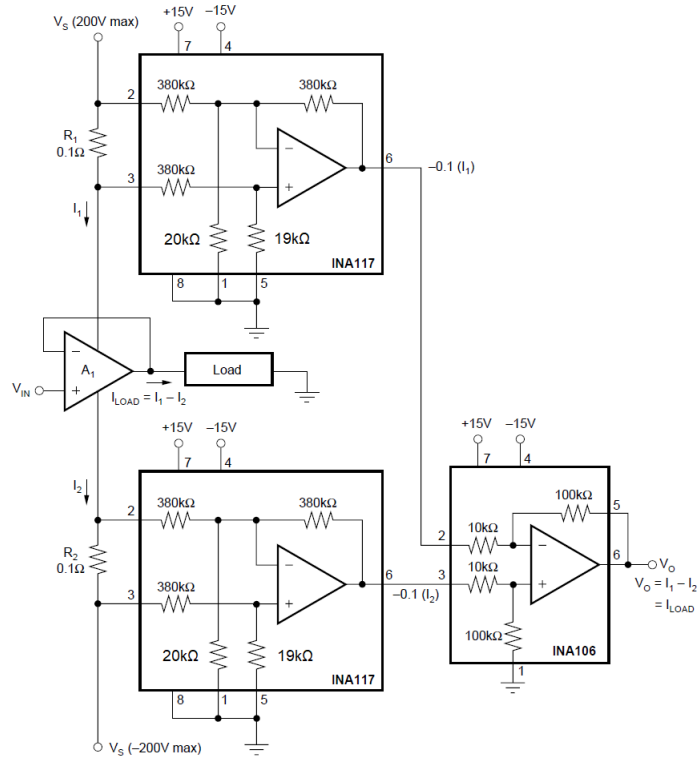

Figure 7-14. Measuring Amplifier Load Current

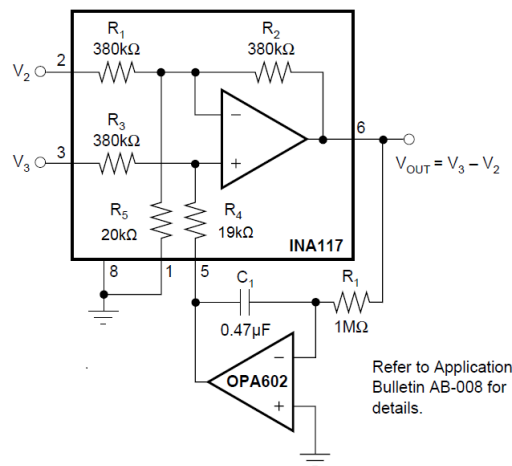

Figure 7-15. AC-coupled INA117

8 Device and Documentation Support

TI offers an extensive line of development tools. Tools and software to evaluate the performance of the device, generate code, and develop solutions are listed below.

8.1 Documentation Support

8.1.1 Related Documentation

- Texas Instruments, [Precision labs series: Instrumentation amplifier](#), videos
- Texas Instruments, [INA149 High common mode voltage difference amplifier](#), data sheet
- Texas Instruments, [Supporting High Voltage Common Mode Using Difference Amplifier](#), application brief

8.2 Receiving Notification of Documentation Updates

To receive notification of documentation updates, navigate to the device product folder on [ti.com](#). Click on *Notifications* to register and receive a weekly digest of any product information that has changed. For change details, review the revision history included in any revised document.

8.3 Support Resources

TI E2E™ [support forums](#) are an engineer's go-to source for fast, verified answers and design help — straight from the experts. Search existing answers or ask your own question to get the quick design help you need.

Linked content is provided "AS IS" by the respective contributors. They do not constitute TI specifications and do not necessarily reflect TI's views; see TI's [Terms of Use](#).

8.4 Trademarks

TI E2E™ is a trademark of Texas Instruments.
All trademarks are the property of their respective owners.

8.5 Electrostatic Discharge Caution



This integrated circuit can be damaged by ESD. Texas Instruments recommends that all integrated circuits be handled with appropriate precautions. Failure to observe proper handling and installation procedures can cause damage.

ESD damage can range from subtle performance degradation to complete device failure. Precision integrated circuits may be more susceptible to damage because very small parametric changes could cause the device not to meet its published specifications.

8.6 Glossary

[TI Glossary](#) This glossary lists and explains terms, acronyms, and definitions.

9 Revision History

NOTE: Page numbers for previous revisions may differ from page numbers in the current version.

Changes from Revision A (November 2000) to Revision B (April 2024)	Page
• Updated the formatting for tables, figures, and cross-references throughout the document.....	1
• Deleted information about the INA117AM and INA117SM variants throughout this document.....	1
• Changed pin 8 from "Comp" to "NC" in the <i>Description</i> and <i>Pin Configuration and Functions</i> sections.....	1
• Added <i>Package Information</i> table to the <i>Description</i> section.....	1
• Added <i>Pin Functions</i> table.....	2
• Added ESD Ratings table.....	3
• Added single supply specification to <i>Recommended Operating Conditions</i>	3
• Added specified temperature range to <i>Recommended Operating Conditions</i>	3
• Added VREF = 0V, VCM = VS/2, and G = 1 to "unless otherwise noted" conditions in <i>Electrical Characteristics</i> and <i>Typical Characteristics</i> for clarity.....	4
• Changed parameter from "Offset voltage vs Temperature" to "Offset voltage drift" in <i>Electrical Characteristics</i>	4
• Added test condition of "TA = –40°C to +85°C" for "Offset voltage drift" in <i>Electrical Characteristics</i>	4
• Changed parameter from "Offset Voltage vs Power Supply" to "Power-supply rejection ratio" in <i>Electrical Characteristics</i>	4
• Added test condition of "TA = –40°C to +85°C" for "CMRR" in <i>Electrical Characteristics</i>	4
• Changed "Common-mode input impedance" typical value from 400kΩ to 200kΩ in <i>Electrical Characteristics</i>	4
• Added test condition "TA = –40°C to +85°C" for "Gain error vs temperature" in <i>Electrical Characteristics</i> and renamed to "Gain error drift" for clarity.....	4
• Changed "Gain nonlinearity" typical value from 0.0002% to 0.0005% in <i>Electrical Characteristics</i>	4
• Added test condition "Continuous to VS/2" to Short-circuit current specification in <i>Electrical Characteristics</i> for clarity.....	4
• Change minimum Slew rate from 2V/μs to 1.7V/μs in <i>Electrical Characteristics</i>	4
• Deleted redundant voltage range, operating temperature range, and specification temperature range specifications from <i>Electrical Characteristics</i>	4
• Deleted <i>Reducing Differential Gain</i> application circuit figure	11
• Added <i>Documentation Support</i> and <i>Related Documentation</i> sections.....	17

10 Mechanical, Packaging, and Orderable Information

The following pages include mechanical, packaging, and orderable information. This information is the most current data available for the designated devices. This data is subject to change without notice and revision of this document. For browser-based versions of this data sheet, refer to the left-hand navigation.

PACKAGING INFORMATION

Orderable Device	Status (1)	Package Type	Package Drawing	Pins	Package Qty	Eco Plan (2)	Lead finish/ Ball material (6)	MSL Peak Temp (3)	Op Temp (°C)	Device Marking (4/5)	Samples
INA117AM	NRND	TO-99	LMC	8	20	RoHS & Green	Call TI	N / A for Pkg Type		INA117AM	
INA117BM	ACTIVE	TO-99	LMC	8	20	RoHS & Green	Call TI	N / A for Pkg Type		INA117BM	Samples
INA117KU	ACTIVE	SOIC	D	8	75	RoHS & Green	NIPDAU	Level-3-260C-168 HR	-40 to 85	INA 117KU 2	Samples
INA117KU/2K5	ACTIVE	SOIC	D	8	2500	RoHS & Green	NIPDAU	Level-3-260C-168 HR		INA 117KU 2	Samples
INA117KU/2K5G4	LIFEBUY	SOIC	D	8	2500	RoHS & Green	NIPDAU	Level-3-260C-168 HR		INA 117KU 2	
INA117P	ACTIVE	PDIP	P	8	50	RoHS & Green	NIPDAU	N / A for Pkg Type		INA117P	Samples
INA117SM	NRND	TO-99	LMC	8	20	RoHS & Green	AU	N / A for Pkg Type		INA117SM	
INA117SMQ	NRND	TO-99	LMC	8	20	RoHS & Green	AU	N / A for Pkg Type		INA117SMQ	

(1) The marketing status values are defined as follows:

ACTIVE: Product device recommended for new designs.

LIFEBUY: TI has announced that the device will be discontinued, and a lifetime-buy period is in effect.

NRND: Not recommended for new designs. Device is in production to support existing customers, but TI does not recommend using this part in a new design.

PREVIEW: Device has been announced but is not in production. Samples may or may not be available.

OBSELETE: TI has discontinued the production of the device.

(2) **RoHS:** TI defines "RoHS" to mean semiconductor products that are compliant with the current EU RoHS requirements for all 10 RoHS substances, including the requirement that RoHS substance do not exceed 0.1% by weight in homogeneous materials. Where designed to be soldered at high temperatures, "RoHS" products are suitable for use in specified lead-free processes. TI may reference these types of products as "Pb-Free".

RoHS Exempt: TI defines "RoHS Exempt" to mean products that contain lead but are compliant with EU RoHS pursuant to a specific EU RoHS exemption.

Green: TI defines "Green" to mean the content of Chlorine (Cl) and Bromine (Br) based flame retardants meet JS709B low halogen requirements of <=1000ppm threshold. Antimony trioxide based flame retardants must also meet the <=1000ppm threshold requirement.

(3) MSL, Peak Temp. - The Moisture Sensitivity Level rating according to the JEDEC industry standard classifications, and peak solder temperature.

(4) There may be additional marking, which relates to the logo, the lot trace code information, or the environmental category on the device.

⁽⁵⁾ Multiple Device Markings will be inside parentheses. Only one Device Marking contained in parentheses and separated by a "~" will appear on a device. If a line is indented then it is a continuation of the previous line and the two combined represent the entire Device Marking for that device.

⁽⁶⁾ Lead finish/Ball material - Orderable Devices may have multiple material finish options. Finish options are separated by a vertical ruled line. Lead finish/Ball material values may wrap to two lines if the finish value exceeds the maximum column width.

Important Information and Disclaimer:The information provided on this page represents TI's knowledge and belief as of the date that it is provided. TI bases its knowledge and belief on information provided by third parties, and makes no representation or warranty as to the accuracy of such information. Efforts are underway to better integrate information from third parties. TI has taken and continues to take reasonable steps to provide representative and accurate information but may not have conducted destructive testing or chemical analysis on incoming materials and chemicals. TI and TI suppliers consider certain information to be proprietary, and thus CAS numbers and other limited information may not be available for release.

In no event shall TI's liability arising out of such information exceed the total purchase price of the TI part(s) at issue in this document sold by TI to Customer on an annual basis.

TAPE AND REEL INFORMATION

QUADRANT ASSIGNMENTS FOR PIN 1 ORIENTATION IN TAPE



*All dimensions are nominal

Device	Package Type	Package Drawing	Pins	SPQ	Reel Diameter (mm)	Reel Width W1 (mm)	A0 (mm)	B0 (mm)	K0 (mm)	P1 (mm)	W (mm)	Pin1 Quadrant
INA117KU/2K5	SOIC	D	8	2500	330.0	12.4	6.4	5.2	2.1	8.0	12.0	Q1

TAPE AND REEL BOX DIMENSIONS

*All dimensions are nominal

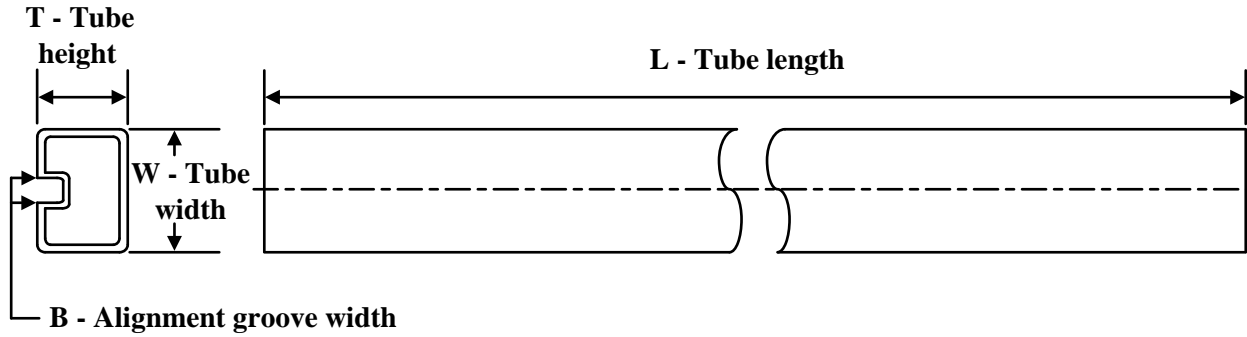
Device	Package Type	Package Drawing	Pins	SPQ	Length (mm)	Width (mm)	Height (mm)
INA117KU/2K5	SOIC	D	8	2500	356.0	356.0	35.0

TUBE

*All dimensions are nominal

Device	Package Name	Package Type	Pins	SPQ	L (mm)	W (mm)	T (μm)	B (mm)
INA117AM	LMC	TO-CAN	8	20	532.13	21.59	889	NA
INA117BM	LMC	TO-CAN	8	20	532.13	21.59	889	NA
INA117KU	D	SOIC	8	75	506.6	8	3940	4.32
INA117P	P	PDIP	8	50	506	13.97	11230	4.32
INA117SM	LMC	TO-CAN	8	20	532.13	21.59	889	NA
INA117SMQ	LMC	TO-CAN	8	20	532.13	21.59	889	NA

IMPORTANT NOTICE AND DISCLAIMER

TI PROVIDES TECHNICAL AND RELIABILITY DATA (INCLUDING DATA SHEETS), DESIGN RESOURCES (INCLUDING REFERENCE DESIGNS), APPLICATION OR OTHER DESIGN ADVICE, WEB TOOLS, SAFETY INFORMATION, AND OTHER RESOURCES "AS IS" AND WITH ALL FAULTS, AND DISCLAIMS ALL WARRANTIES, EXPRESS AND IMPLIED, INCLUDING WITHOUT LIMITATION ANY IMPLIED WARRANTIES OF MERCHANTABILITY, FITNESS FOR A PARTICULAR PURPOSE OR NON-INFRINGEMENT OF THIRD PARTY INTELLECTUAL PROPERTY RIGHTS.

These resources are intended for skilled developers designing with TI products. You are solely responsible for (1) selecting the appropriate TI products for your application, (2) designing, validating and testing your application, and (3) ensuring your application meets applicable standards, and any other safety, security, regulatory or other requirements.

These resources are subject to change without notice. TI grants you permission to use these resources only for development of an application that uses the TI products described in the resource. Other reproduction and display of these resources is prohibited. No license is granted to any other TI intellectual property right or to any third party intellectual property right. TI disclaims responsibility for, and you will fully indemnify TI and its representatives against, any claims, damages, costs, losses, and liabilities arising out of your use of these resources.

TI's products are provided subject to [TI's Terms of Sale](#) or other applicable terms available either on [ti.com](https://www.ti.com) or provided in conjunction with such TI products. TI's provision of these resources does not expand or otherwise alter TI's applicable warranties or warranty disclaimers for TI products.

TI objects to and rejects any additional or different terms you may have proposed.

Mailing Address: Texas Instruments, Post Office Box 655303, Dallas, Texas 75265
Copyright © 2024, Texas Instruments Incorporated

Looking for pricing, stock, or lifecycle information?

Click below to explore more details on WIN SOURCE:

 [View INA117KU/2K5 on WIN SOURCE](#)

 [Texas Instruments](#) Information

Optimize Your Supply Chain with WIN SOURCE Solutions

-  Global Sourcing Solution
-  Obsolete Management
-  Cost Control Management
-  Shortage Management
-  Alternative Solution
-  Excess Inventory Management