

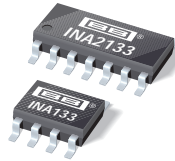

**THE DATASHEET OF  
INA133U/2K5**





# INA133 INA2133

For most current data sheet and other product information, visit [www.burr-brown.com](http://www.burr-brown.com)

## High-Speed, Precision DIFFERENCE AMPLIFIERS

### FEATURES

- DESIGNED FOR LOW COST
- SINGLE, DUAL VERSIONS
- LOW OFFSET VOLTAGE DRIFT:  $\pm 450\mu\text{V}$  max,  $\pm 5\mu\text{V}/^\circ\text{C}$  max
- LOW GAIN ERROR: 0.05% max
- WIDE BANDWIDTH: 1.5MHz
- HIGH SLEW RATE: 5V/ $\mu\text{s}$
- FAST SETTLING TIME: 5.5 $\mu\text{s}$  to 0.01%
- LOW QUIESCENT CURRENT: 950 $\mu\text{A}$
- WIDE SUPPLY RANGE:  $\pm 2.25\text{V}$  to  $\pm 18\text{V}$
- SO-8 and SO-14 PACKAGES

### DESCRIPTION

The INA133 and INA2133 are high slew rate, unity-gain difference amplifiers consisting of a precision op amp with a precision resistor network. The on-chip resistors are laser trimmed for accurate gain and high common-mode rejection. Excellent TCR tracking of the resistors maintains gain accuracy and common-mode rejection over temperature. They operate over a wide supply range,  $\pm 2.25\text{V}$  to  $\pm 18\text{V}$  ( $+4.5\text{V}$  to  $+36\text{V}$  single supply), and input common-mode voltage range extends beyond the positive and negative supply rails.

### APPLICATIONS

- DIFFERENTIAL INPUT AMPLIFIER BUILDING BLOCK
- DIFF IN/DIFF OUT AMPLIFIER
- UNITY-GAIN INVERTING AMPLIFIER
- GAIN = +1/2 OR G = +2 AMPLIFIER
- SUMMING AMPLIFIER
- SYNCHRONOUS DEMODULATOR
- CURRENT/DIFFERENTIAL LINE RECEIVER
- VOLTAGE-CONTROLLED CURRENT SOURCE
- BATTERY POWERED SYSTEMS
- LOW COST AUTOMOTIVE

The differential amplifier is the foundation of many commonly used circuits. The low cost INA133 and INA2133 provide this precision circuit function without using an expensive precision network.

The single version, INA133, package is the SO-8 surface mount. The dual version, INA2133, package is the SO-14 surface mount. Both are specified for operation over the extended industrial temperature range,  $-40^\circ\text{C}$  to  $+85^\circ\text{C}$ . Operation is from  $-55^\circ\text{C}$  to  $+125^\circ\text{C}$ .

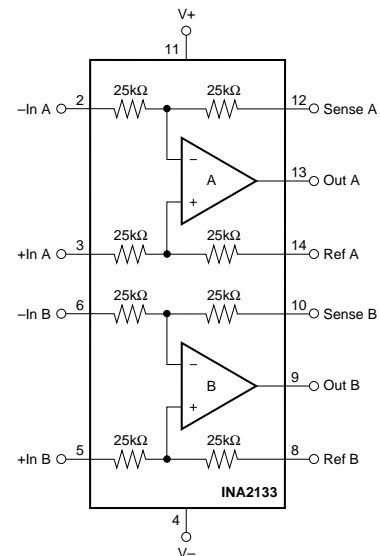
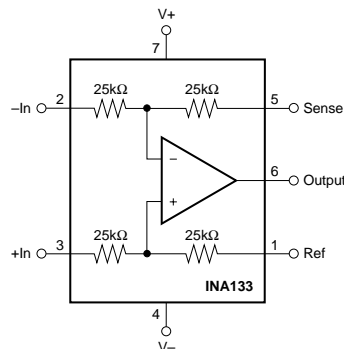

International Airport Industrial Park • Mailing Address: PO Box 11400, Tucson, AZ 85734 • Street Address: 6730 S. Tucson Blvd., Tucson, AZ 85706 • Tel: (520) 746-1111  
 Twx: 910-952-1111 • Internet: <http://www.burr-brown.com/> • Cable: BBRCORP • Telex: 066-6491 • FAX: (520) 889-1510 • Immediate Product Info: (800) 548-6132

# SPECIFICATIONS: $V_S = \pm 15V$

At  $T_A = +25^\circ C$ ,  $V_S = \pm 15V$ ,  $R_L = 10k\Omega$  connected to ground, and reference pin connected to ground, unless otherwise noted.

PARAMETER	CONDITIONS	INA133U INA2133U			INA133UA INA2133UA			UNITS
		MIN	TYP	MAX	MIN	TYP	MAX	
<b>OFFSET VOLTAGE<sup>(1)</sup></b> Initial <sup>(1)</sup> vs Temperature vs Power Supply vs Time Channel Separation (dual)	RTO $V_{CM} = 0V$ $T_A = -40^\circ C$ to $+85^\circ C$ $V_S = \pm 2.25V$ to $\pm 18V$ dc		$\pm 150$ $\pm 2$ $\pm 10$ 0.3 120	$\pm 450$ $\pm 5$ $\pm 30$		* See Typical Curve 900 *	$\pm 900$ $\pm 50$	$\mu V$ $\mu V/^\circ C$ $\mu V/V$ $\mu V/\sqrt{m\Omega}$ dB
<b>INPUT IMPEDANCE<sup>(2)</sup></b> Differential Common-Mode	$V_{CM} = 0V$		50 25			* *		k $\Omega$ k $\Omega$
<b>INPUT VOLTAGE RANGE</b> Common-Mode Voltage Range Positive Negative Common-Mode Rejection Ratio	$V_O = 0V$ $V_O = 0V$ $V_{CM} = -27V$ to $+27V$ , $R_S = 0\Omega$	2(V+) -3 2(V-) +3 80	2(V+) -2 2(V-) +2 90		* *	* *		V V dB
<b>OUTPUT VOLTAGE NOISE<sup>(3)</sup></b> f = 0.1Hz to 10Hz f = 10Hz f = 100Hz f = 1kHz	RTO		2 80 60 57			* * * *		$\mu V_{p-p}$ nV/ $\sqrt{Hz}$ nV/ $\sqrt{Hz}$ nV/ $\sqrt{Hz}$
<b>GAIN</b> Initial Error vs Temperature Nonlinearity	$V_O = -14V$ to $+13.5V$ $T_A = -40^\circ C$ to $+85^\circ C$ $V_O = -14V$ to $+13.5V$		1 $\pm 0.02$ $\pm 1$ $\pm 0.0001$	$\pm 0.05$ $\pm 10$ $\pm 0.001$		* * * *	$\pm 0.1$ * $\pm 0.002$	V/V % ppm/ $^\circ C$ % of FS
<b>OUTPUT</b> Voltage Output Positive Negative Positive Negative Current Limit, Continuous-to-Common Capacitive Load (stable operation)	Gain Error < 0.1% $R_L = 10k\Omega$ to Ground $R_L = 10k\Omega$ to Ground $R_L = 100k\Omega$ to Ground $R_L = 100k\Omega$ to Ground	(V+) -1.5 (V-) +1	(V+) -1.3 (V-) +0.8 (V+) -0.8 (V-) +0.3 -25/+32 1000		* *	* * * * *		V V V V mA pF
<b>FREQUENCY RESPONSE</b> Small-Signal Bandwidth Slew Rate Settling Time: 0.1% 0.01% Overload Recovery Time	-3dB 10V Step, $C_L = 100pF$ 10V Step, $C_L = 100pF$ 50% Overdrive		1.5 5 4 5.5 4			* * * * *		MHz V/ $\mu s$ $\mu s$ $\mu s$ $\mu s$
<b>POWER SUPPLY</b> Rated Voltage Operating Voltage Range Dual Supplies Single Supply Quiescent Current (per amplifier)	$I_O = 0$		$\pm 15$ $\pm 2.25$ +4.5 $\pm 0.95$	$\pm 18$ $\pm 36$ $\pm 1.2$		* * * *	* * *	V V V mA
<b>TEMPERATURE RANGE</b> Specification Operation Storage Thermal Resistance SO-8 Surface Mount SO-14 Surface Mount	$\theta_{JA}$	-40 -55 -55		+85 +125 +125	* * *		* * *	$^\circ C$ $^\circ C$ $^\circ C$ $^\circ C/W$ $^\circ C/W$

\* Specifications the same as INA133U, INA2133U.

NOTES: (1) Includes the effects of amplifier's input bias and offset currents. (2) 25k $\Omega$  resistors are ratio matched but have  $\pm 20\%$  absolute value. (3) Includes effects of amplifier's input current noise and thermal noise contribution of resistor network.

The information provided herein is believed to be reliable; however, BURR-BROWN assumes no responsibility for inaccuracies or omissions. BURR-BROWN assumes no responsibility for the use of this information, and all use of such information shall be entirely at the user's own risk. Prices and specifications are subject to change without notice. No patent rights or licenses to any of the circuits described herein are implied or granted to any third party. BURR-BROWN does not authorize or warrant any BURR-BROWN product for use in life support devices and/or systems.

# SPECIFICATIONS: $V_S = \pm 5V$

At  $T_A = +25^\circ C$ ,  $V_S = \pm 5V$ ,  $R_L = 10k\Omega$  connected to ground, and reference pin connected to ground, unless otherwise noted.

PARAMETER	CONDITIONS	INA133U INA2133U			INA133UA INA2133UA			UNITS
		MIN	TYP	MAX	MIN	TYP	MAX	
<b>OFFSET VOLTAGE<sup>(1)</sup></b> Initial <sup>(1)</sup> vs Temperature	RTO $V_{CM} = 0V$		$\pm 300$ $\pm 2$	$\pm 750$		*	$\pm 1500$	$\mu V$ $\mu V/^\circ C$
<b>INPUT VOLTAGE RANGE</b> Common-Mode Voltage Range Positive Negative Common-Mode Rejection Ratio	$V_O = 0V$ $V_O = 0V$ $V_{CM} = -7V$ to $+7V$ , $R_S = 0\Omega$	$2(V+) - 3$ $2(V-) + 3$ 80	$2(V+) - 2$ $2(V-) + 2$ 90		*	*		V V dB
<b>GAIN</b> Initial Gain Error Nonlinearity	$V_O = -4V$ to $3.5V$ $V_O = -4V$ to $3.5V$		1 $\pm 0.02$ $\pm 0.0001$	$\pm 0.05$ $\pm 0.001$		*	$\pm 0.1$ $\pm 0.002$	V/V % % of FS
<b>OUTPUT</b> Voltage Output Positive Negative Positive Negative	Gain Error < 0.1% $R_L = 10k\Omega$ to Ground $R_L = 10k\Omega$ to Ground $R_L = 100k\Omega$ to Ground $R_L = 100k\Omega$ to Ground	$(V+) - 1.5$ $(V-) + 1$	$(V+) - 1.3$ $(V-) + 0.8$ $(V+) - 0.8$ $(V-) + 0.3$		*	*		V V V V
<b>POWER SUPPLY</b> Rated Voltage Operating Voltage Range Dual Supplies Single Supply Quiescent Current (per amplifier)	$I_O = 0$		$\pm 15$			*		V V V mA

\* Specifications the same as INA133U, INA2133U.

NOTES: (1) Includes the effects of amplifier's input bias and offset currents.

## ABSOLUTE MAXIMUM RATINGS<sup>(1)</sup>

Supply Voltage, $V+$ to $V-$ .....	36V
Input Voltage Range .....	$2 \cdot V_S$
Output Short-Circuit (to ground) <sup>(2)</sup> .....	Continuous
Operating Temperature .....	$-55^\circ C$ to $+125^\circ C$
Storage Temperature .....	$-55^\circ C$ to $+125^\circ C$
Junction Temperature .....	$+150^\circ C$
Lead Temperature (soldering, 10s) .....	$+300^\circ C$

NOTES: (1) Stresses above these ratings may cause permanent damage. Exposure to absolute maximum conditions for extended periods may degrade device reliability. (2) One channel per package.



## ELECTROSTATIC DISCHARGE SENSITIVITY

This integrated circuit can be damaged by ESD. Burr-Brown recommends that all integrated circuits be handled with appropriate precautions. Failure to observe proper handling and installation procedures can cause damage.

ESD damage can range from subtle performance degradation to complete device failure. Precision integrated circuits may be more susceptible to damage because very small parametric changes could cause the device not to meet its published specifications.

## PACKAGE/ORDERING INFORMATION

PRODUCT	PACKAGE	PACKAGE DRAWING NUMBER <sup>(1)</sup>	SPECIFIED TEMPERATURE RANGE	PACKAGE MARKING	ORDERING NUMBER <sup>(2)</sup>	TRANSPORT MEDIA
<b>Single</b>						
INA133U	SO-8 Surface Mount	182	$-40^\circ C$ to $+85^\circ C$	INA133U	INA133U	Rails
"	"	"	"	"	INA133U/2K5	Tape and Reel
INA133UA	SO-8 Surface Mount	182	$-40^\circ C$ to $+85^\circ C$	INA133UA	INA133UA	Rails
"	"	"	"	"	INA133UA/2K5	Tape and Reel
<b>Dual</b>						
INA2133U	SO-14 Surface Mount	235	$-40^\circ C$ to $+85^\circ C$	INA2133U	INA2133U	Rails
"	"	"	"	"	INA2133U/2K5	Tape and Reel
INA2133UA	SO-14 Surface Mount	235	$-40^\circ C$ to $+85^\circ C$	INA2133UA	INA2133UA	Rails
"	"	"	"	"	INA2133UA/2K5	Tape and Reel

NOTES: (1) For detailed drawing and dimension table, please see end of data sheet, or Appendix C of Burr-Brown IC Data Book. (2) Models with a slash (/) are available only in Tape and Reel in the quantities indicated (e.g., /2K5 indicates 2500 devices per reel). Ordering 2500 pieces of "INA133UA/2K5" will get a single 2500-piece Tape and Reel. For detailed Tape and Reel mechanical information, refer to Appendix B of Burr-Brown IC Data Book.

# PIN CONFIGURATIONS

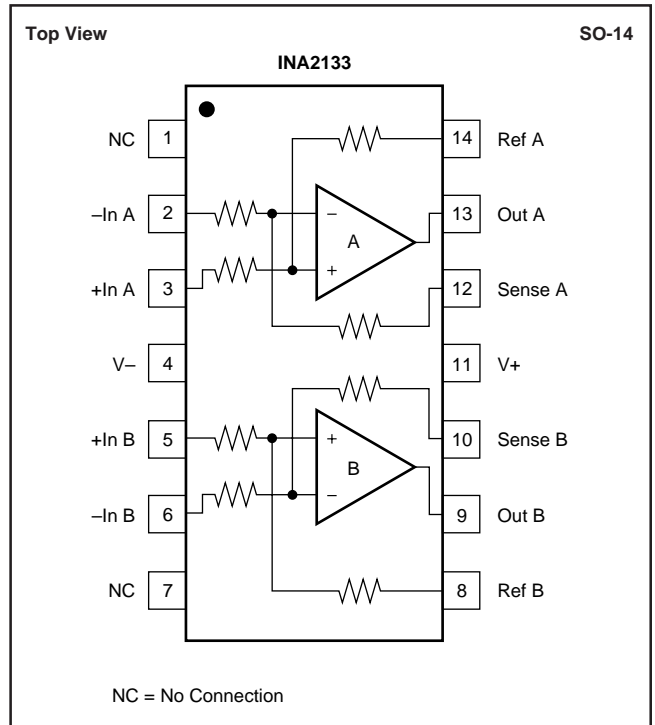
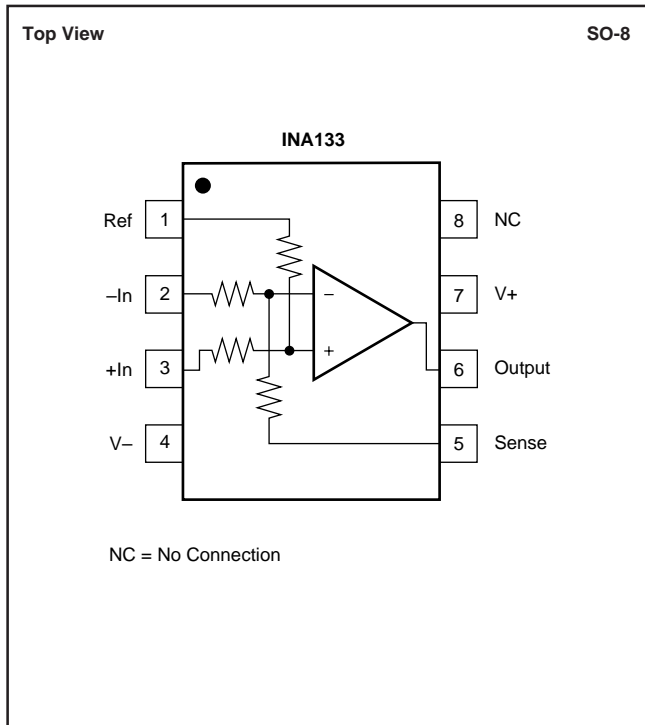

# TYPICAL PERFORMANCE CURVES

At  $T_A = +25^\circ\text{C}$ ,  $V_S = \pm 15\text{V}$ ,  $R_L = 10\text{k}\Omega$  connected to ground, and reference pin connected to ground, unless otherwise noted.

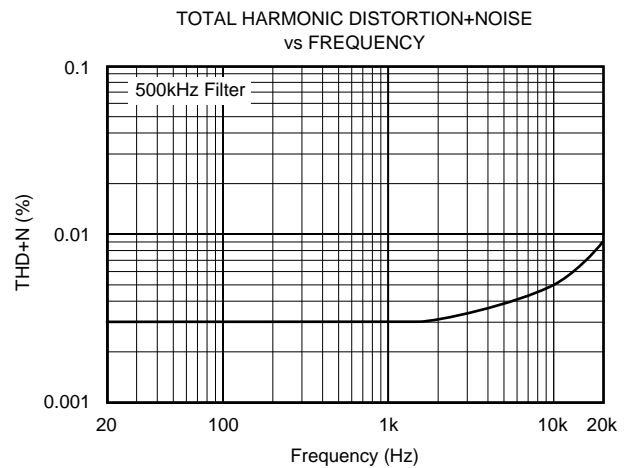
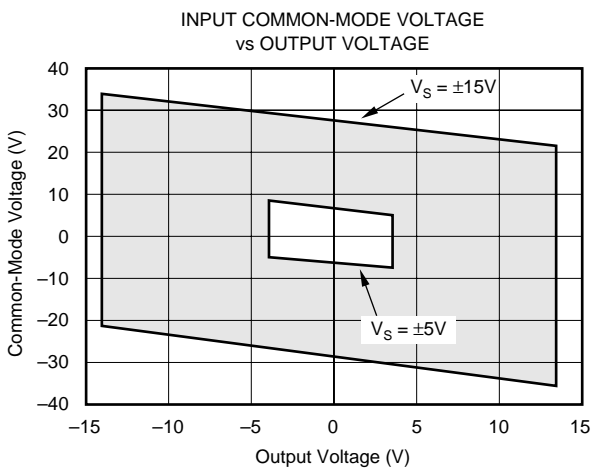
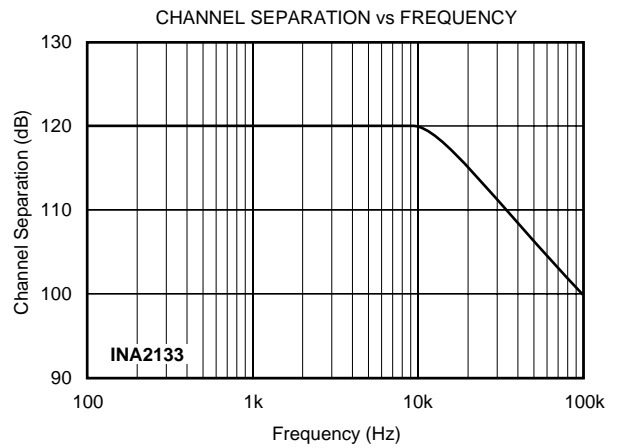
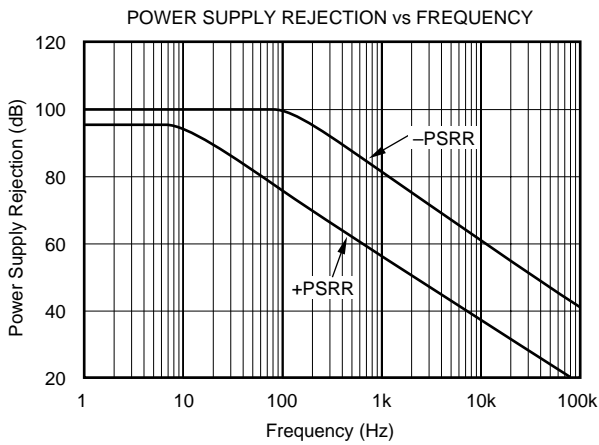
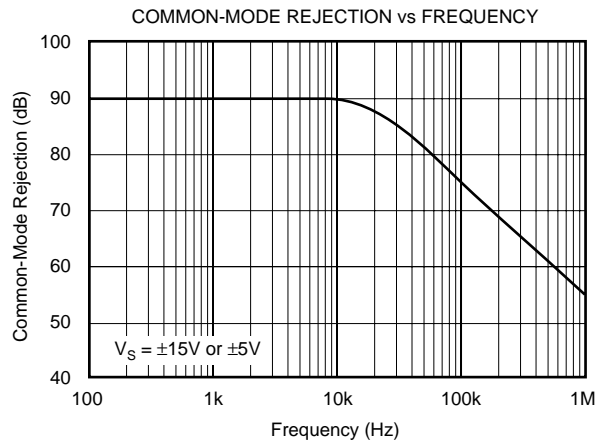
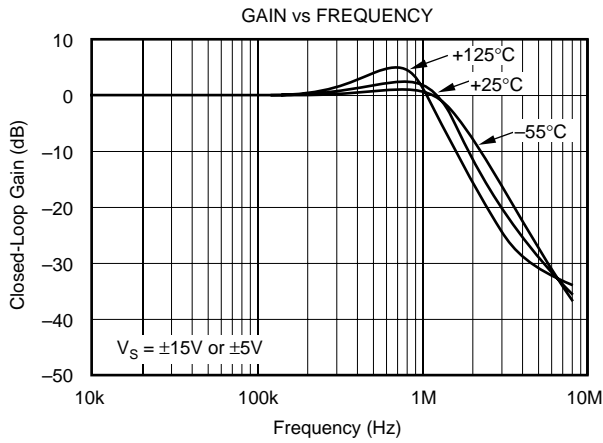

# TYPICAL PERFORMANCE CURVES (CONT)

At  $T_A = +25^\circ\text{C}$ ,  $V_S = \pm 15\text{V}$ ,  $R_L = 10\text{k}\Omega$  connected to ground, and reference pin connected to ground, unless otherwise noted.

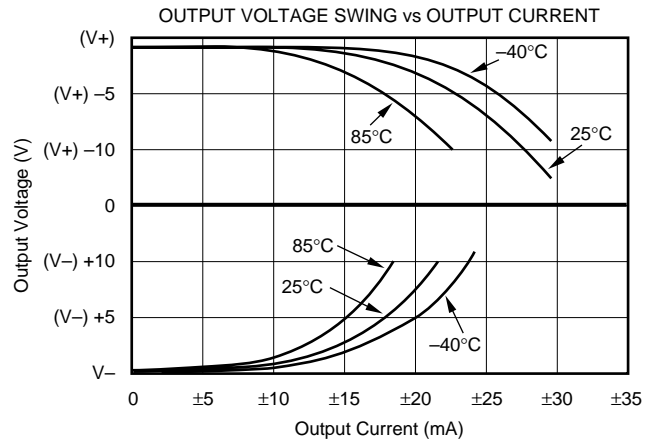
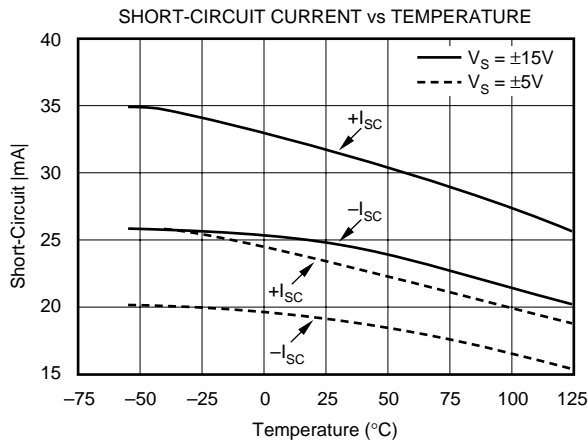
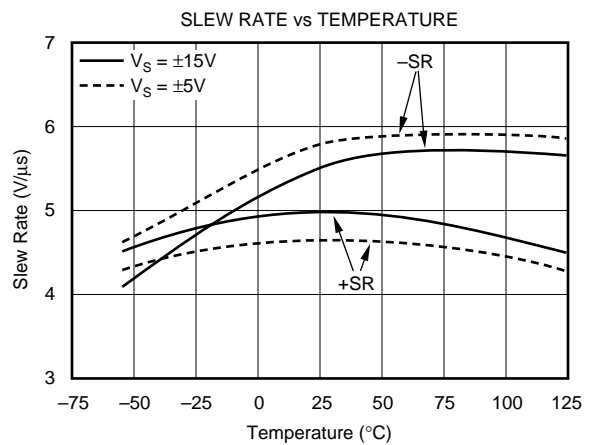
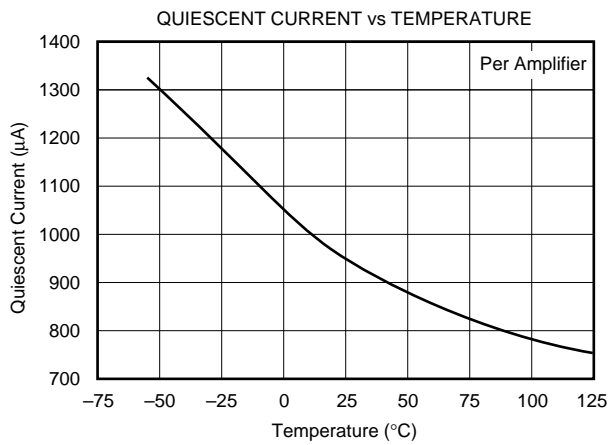
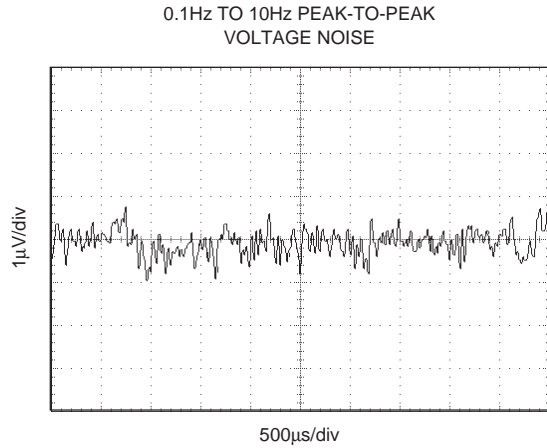
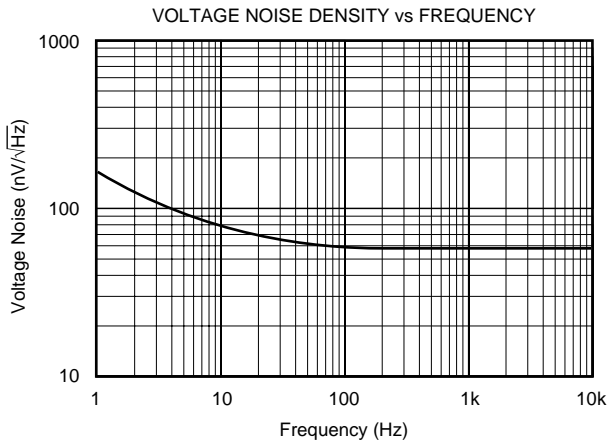

# TYPICAL PERFORMANCE CURVES (CONT)

At  $T_A = +25^\circ\text{C}$ ,  $V_S = \pm 15\text{V}$ ,  $R_L = 10\text{k}\Omega$  connected to ground, and reference pin connected to ground, unless otherwise noted.

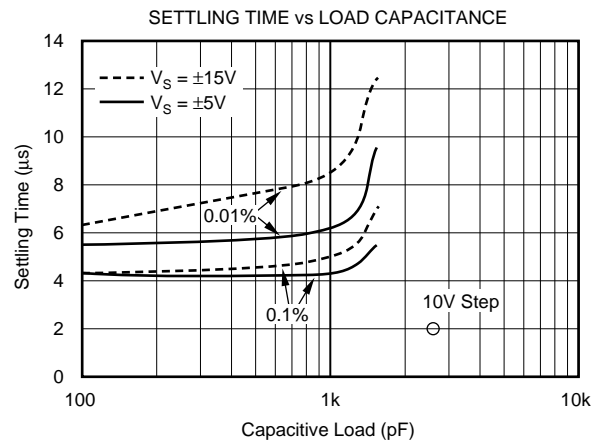
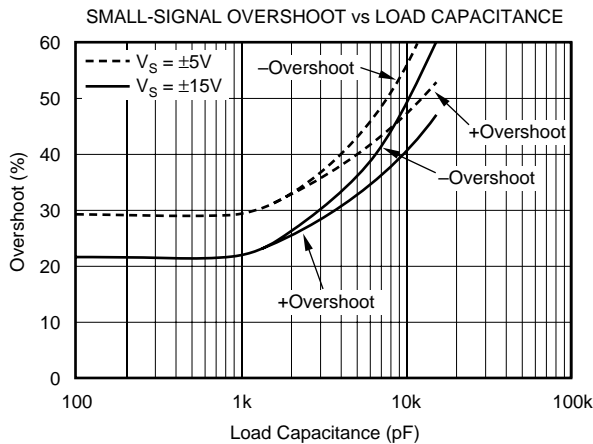
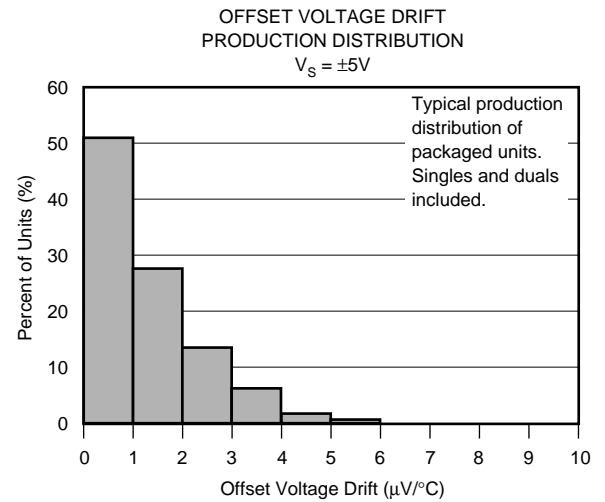
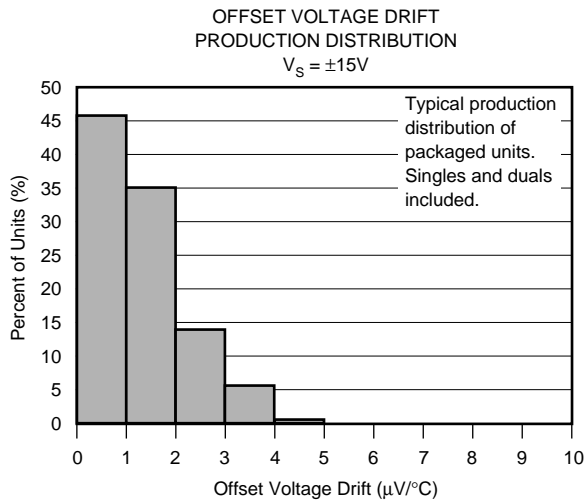
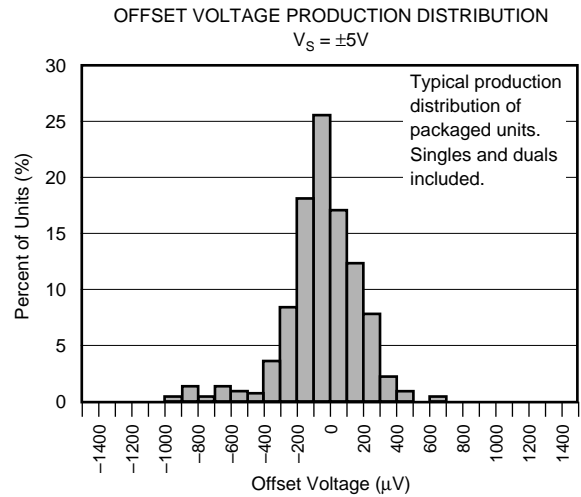
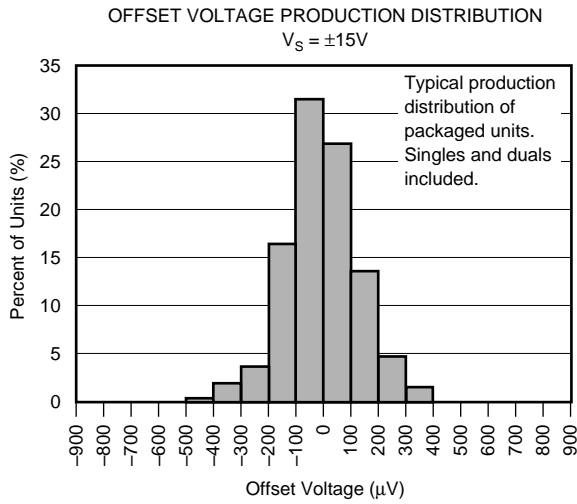

# TYPICAL PERFORMANCE CURVES (CONT)

At  $T_A = +25^\circ\text{C}$ ,  $V_S = \pm 15\text{V}$ ,  $R_L = 10\text{k}\Omega$  connected to ground, and reference pin connected to ground, unless otherwise noted.

SMALL-SIGNAL STEP RESPONSE

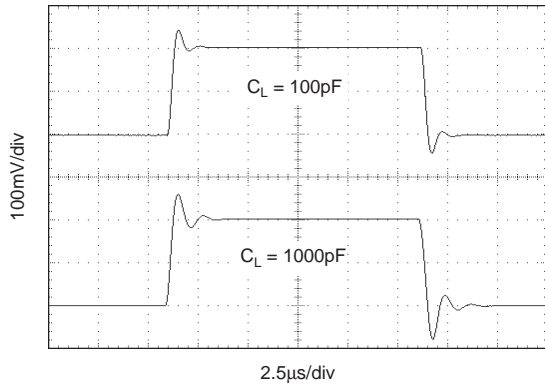

LARGE-SIGNAL STEP RESPONSE

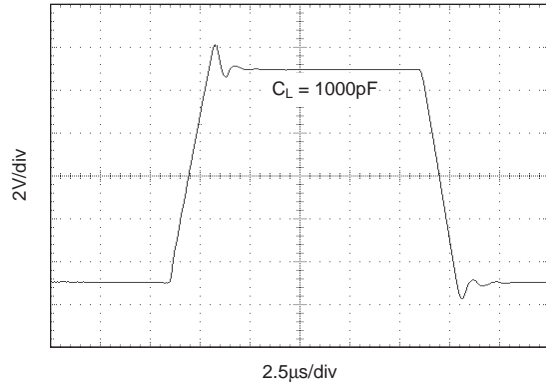

MAXIMUM OUTPUT VOLTAGE vs FREQUENCY

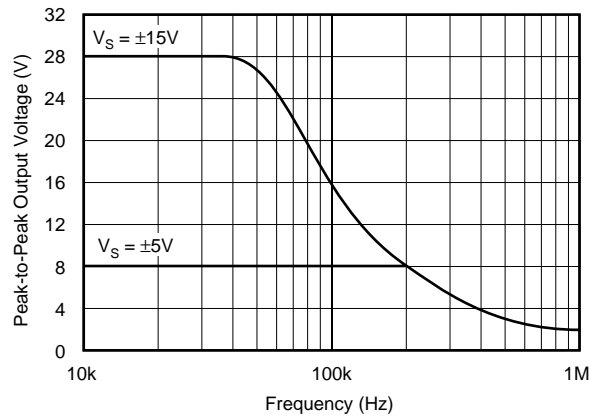

## APPLICATIONS INFORMATION

The INA133 and INA2133 are high-speed difference amplifiers suitable for a wide range of general purpose applications. Figure 1 shows the basic connections required for operation of the INA133. Decoupling capacitors are strongly recommended in applications with noisy or high impedance power supplies. The capacitors should be placed close to the device pins as shown in Figure 1. All circuitry is completely independent in the dual version assuring lowest crosstalk and normal behavior when one amplifier is overdriven or short-circuited.

As shown in Figure 1, the differential input signal is connected to pins 2 and 3. The source impedances connected to the inputs must be nearly equal to assure good common-mode rejection. A  $5\Omega$  mismatch in source impedance will degrade the common-mode rejection of a typical device to approximately 80dB (a  $10\Omega$  mismatch degrades CMR to 74dB). If the source has a known impedance mismatch, an additional resistor in series with the opposite input can be used to preserve good common-mode rejection.

The INA133's internal resistors are accurately ratio trimmed to match. That is,  $R_1$  is trimmed to match  $R_2$  and  $R_3$  is trimmed to match  $R_4$ . However, the absolute values may not be equal ( $R_1 + R_2$  may be slightly different than  $R_3 + R_4$ ). Thus, large series resistors on the input (greater than  $250\Omega$ ), even if well matched, will degrade common-mode rejection.

Circuit board layout constraints might suggest possible variations in connections of the internal resistors. For instance, it appears that pins 1 and 3 could be interchanged. However, because of the ratio trimming technique used (see paragraph above) CMRR will be degraded. If pins 1 and 3 are inter-

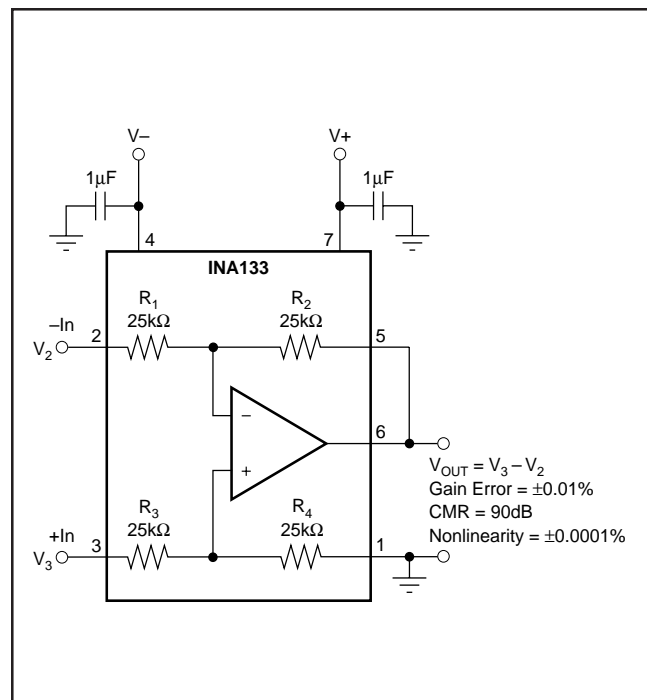

FIGURE 1. Precision Difference Amplifier (Basic Power Supply and Signal Connections).

changed, pins 2 and 5 must also be interchanged to maintain proper ratio matching.

## OPERATING VOLTAGE

The INA133 and INA2133 operate from single (+4.5V to +36V) or dual ( $\pm 2.25V$  to  $\pm 18V$ ) supplies with excellent performance. Specifications are production tested with  $\pm 5V$  and  $\pm 15V$  supplies. Most behavior remains unchanged throughout the full operating voltage range. Parameters which vary significantly with operating voltage are shown in the Typical Performance Curves.

## INPUT VOLTAGE

The INA133 and INA2133 can accurately measure differential signals that are above and below the supply rails. Linear common-mode range extends from  $2 \cdot (V+) - 3V$  to  $2 \cdot (V-) + 3V$  (nearly twice the supplies). See the typical performance curve, "Input Common-Mode Voltage vs Output Voltage."

## OFFSET VOLTAGE TRIM

The INA133 and INA2133 are laser trimmed for low offset voltage and drift. Most applications require no external offset adjustment. Figure 2 shows an optional circuit for trimming the output offset voltage. The output is referred to the output reference terminal (pin 1), which is normally grounded. A voltage applied to the Ref terminal will be summed with the output signal. This can be used to null offset voltage as shown in Figure 2. The source impedance of a signal applied to the Ref terminal should be less than  $10\Omega$  to maintain good common-mode rejection.

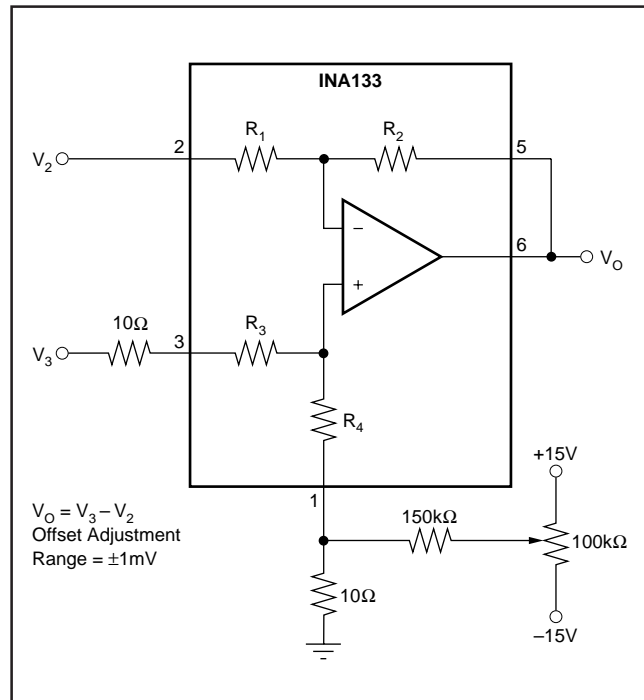
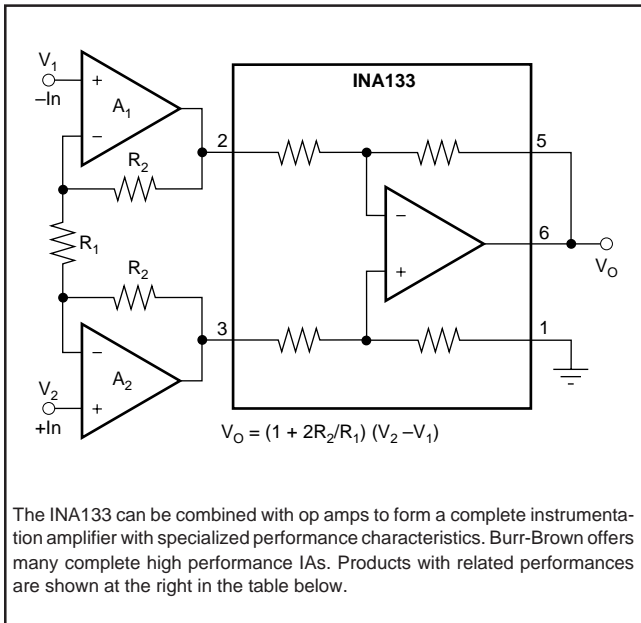

FIGURE 2. Offset Adjustment.

# TYPICAL APPLICATIONS



A <sub>1</sub> , A <sub>2</sub>	FEATURE	SIMILAR COMPLETE BURR-BROWN IA
OPA2227	Low Noise	INA103
OPA129	Ultra Low Bias Current (fA)	INA116
OPA2277	Low Offset Drift, Low Noise	INA114, INA128
OPA2130	Low Power, FET-Input (pA)	INA121
OPA2234	Single Supply, Precision, Low Power	INA122, INA118
OPA2237	Single Supply, Low Power, MSOP-8	INA122, INA126

FIGURE 3. Precision Instrumentation Amplifier.

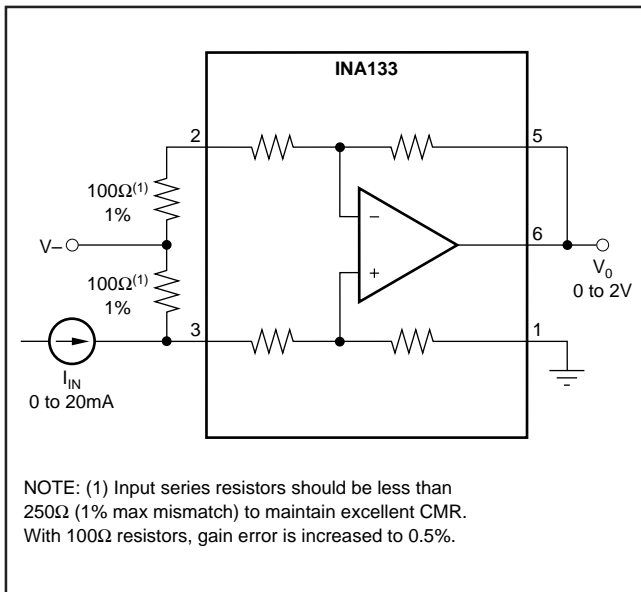

FIGURE 4. Current Receiver with Compliance to Rails.

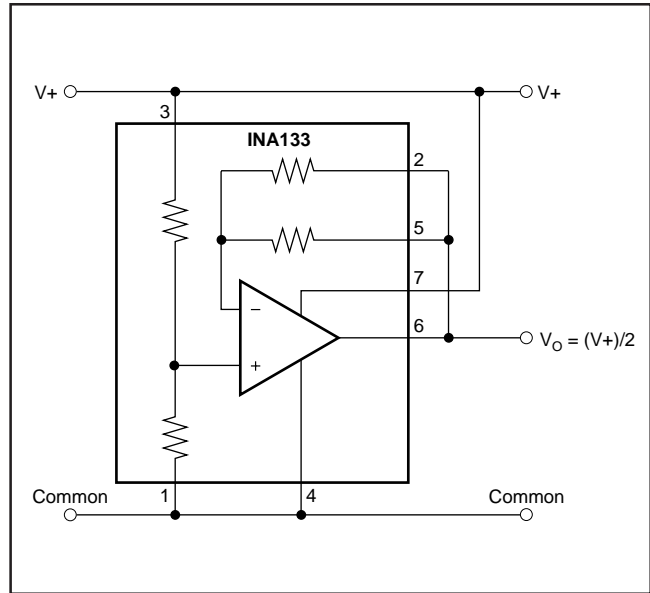

FIGURE 5. Pseudoground Generator.

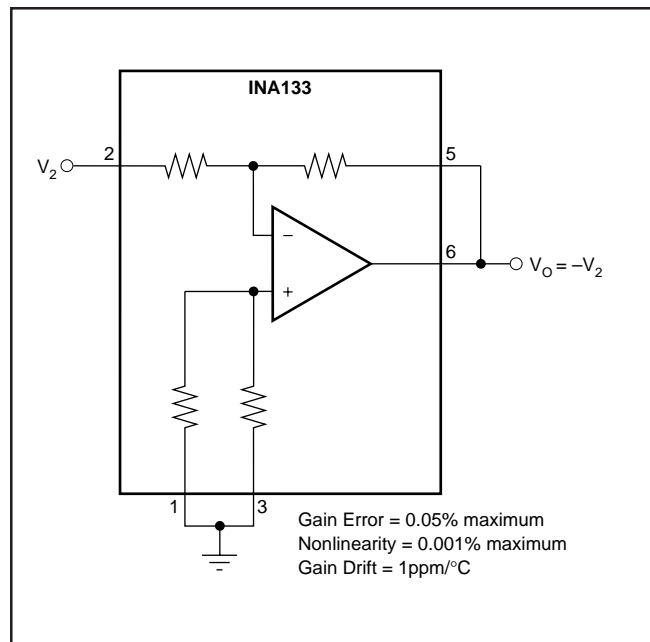

FIGURE 6. Precision Unity-Gain Inverting Amplifier.

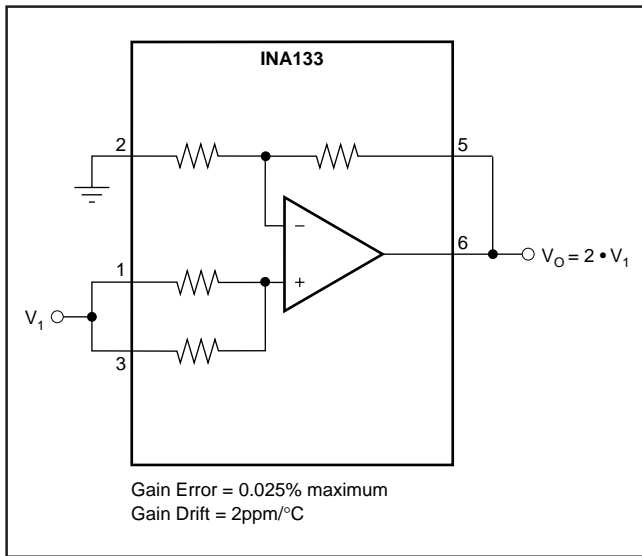

FIGURE 7. Precision Gain = 2 Amplifier.

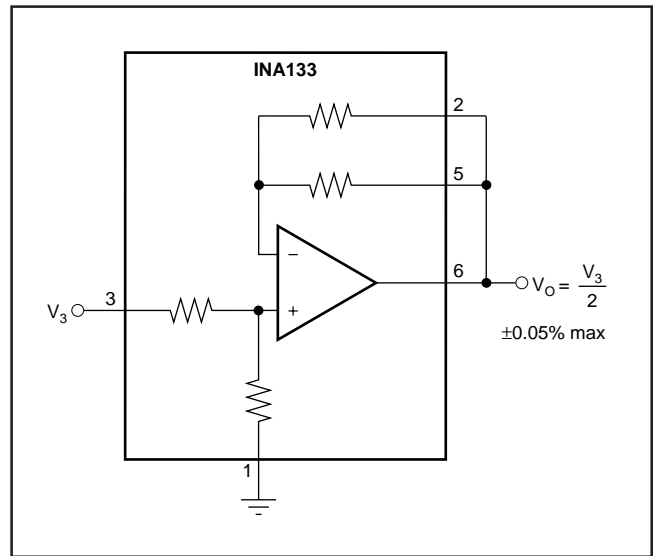

FIGURE 8. Precision Gain = 1/2 Amplifier.

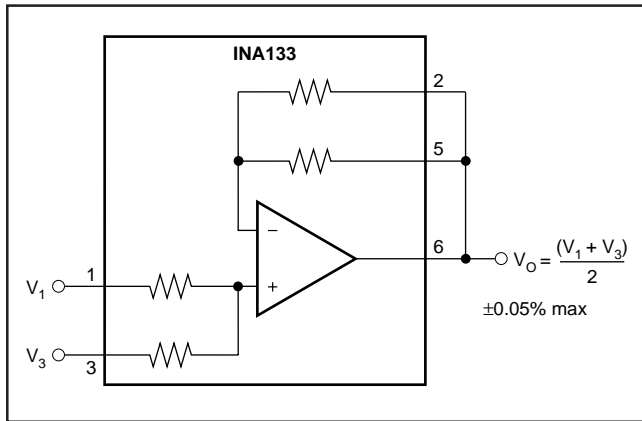

FIGURE 9. Precision Average Value Amplifier.

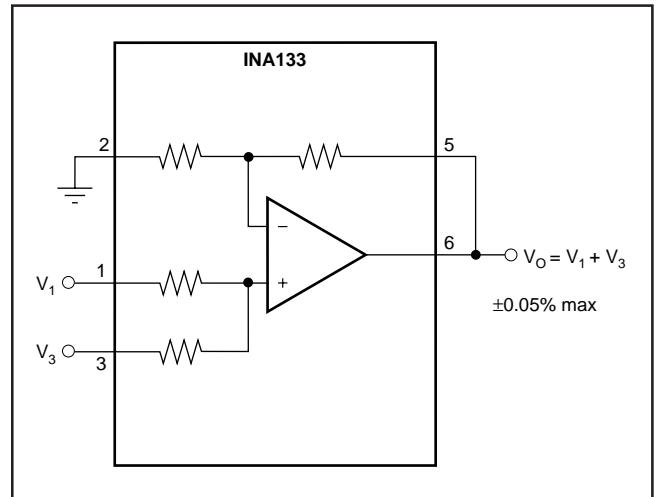

FIGURE 10. Precision Summing Amplifier.

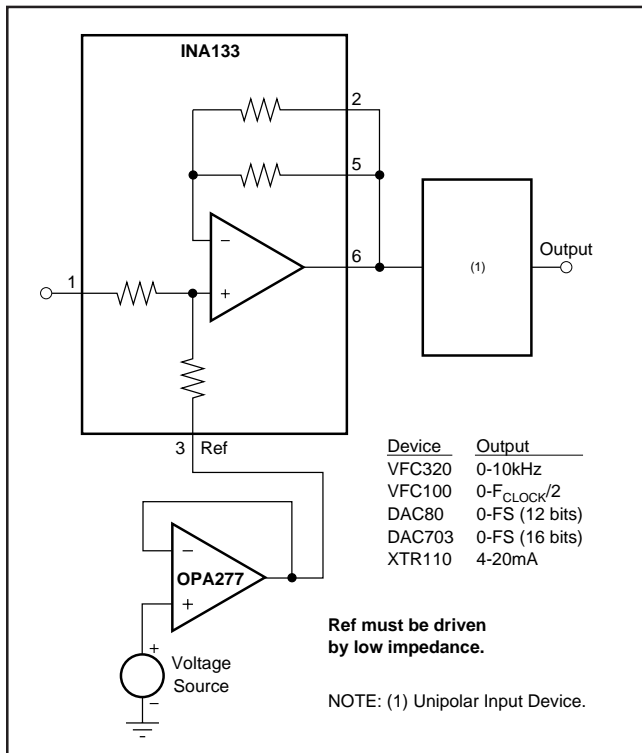

FIGURE 11. Precision Bipolar Offsetting.

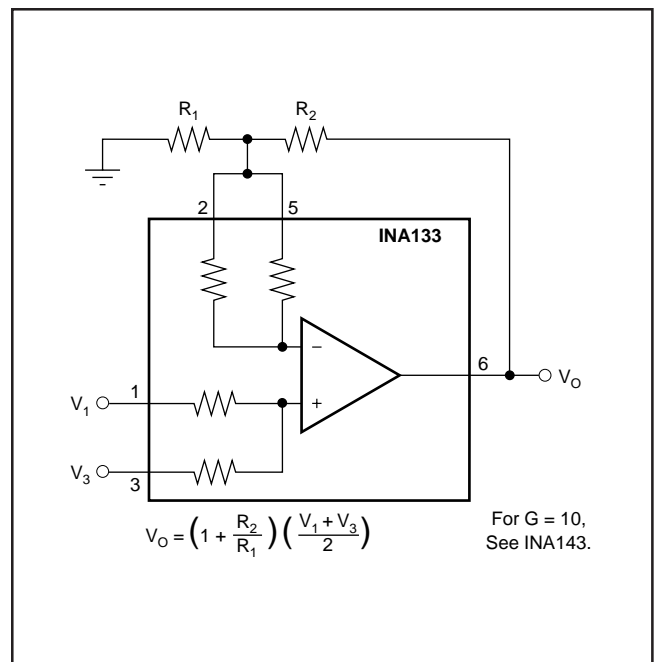

FIGURE 12. Precision Summing Amplifier with Gain.

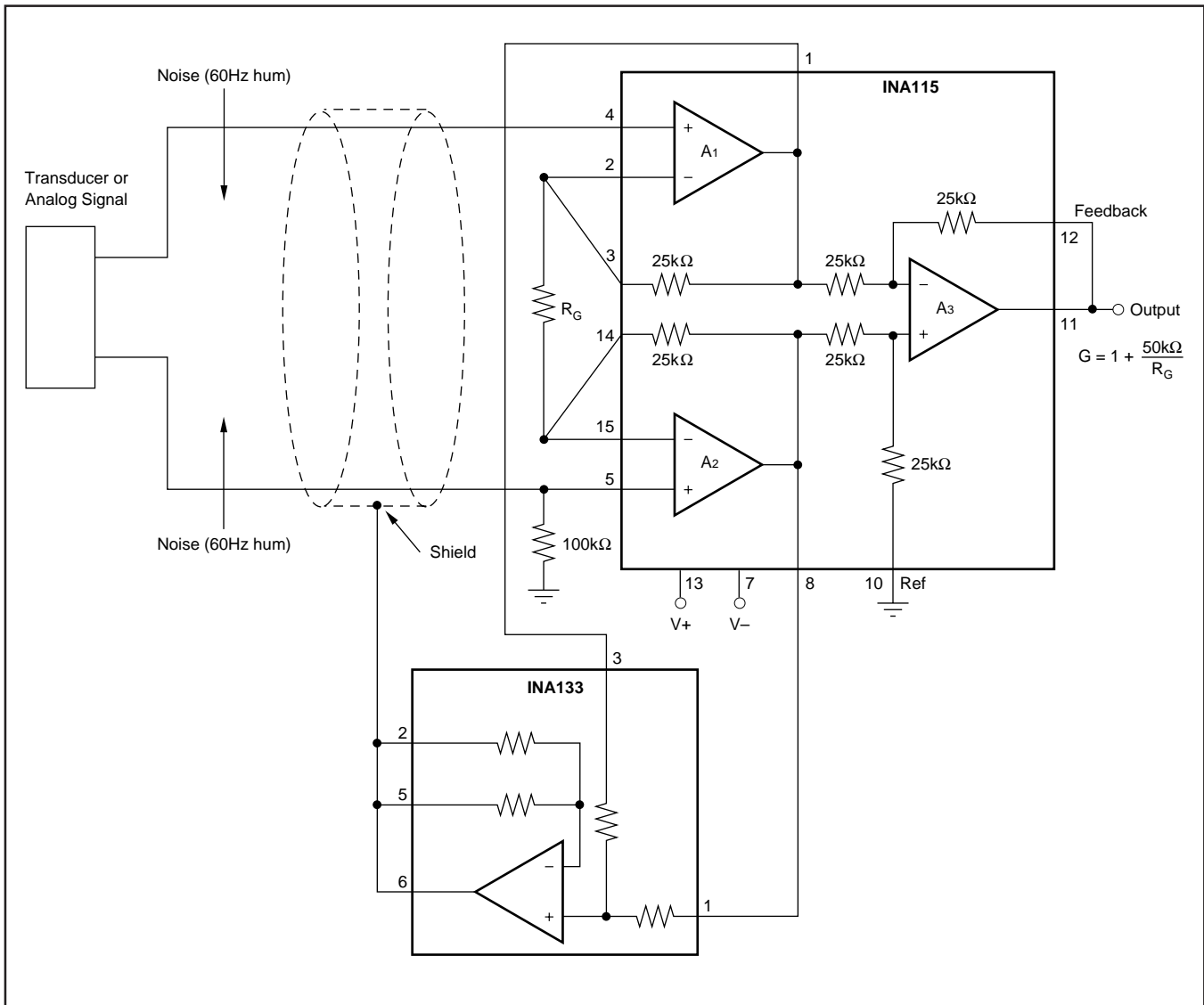

FIGURE 13. Instrumentation Amplifier Guard Drive Generator.

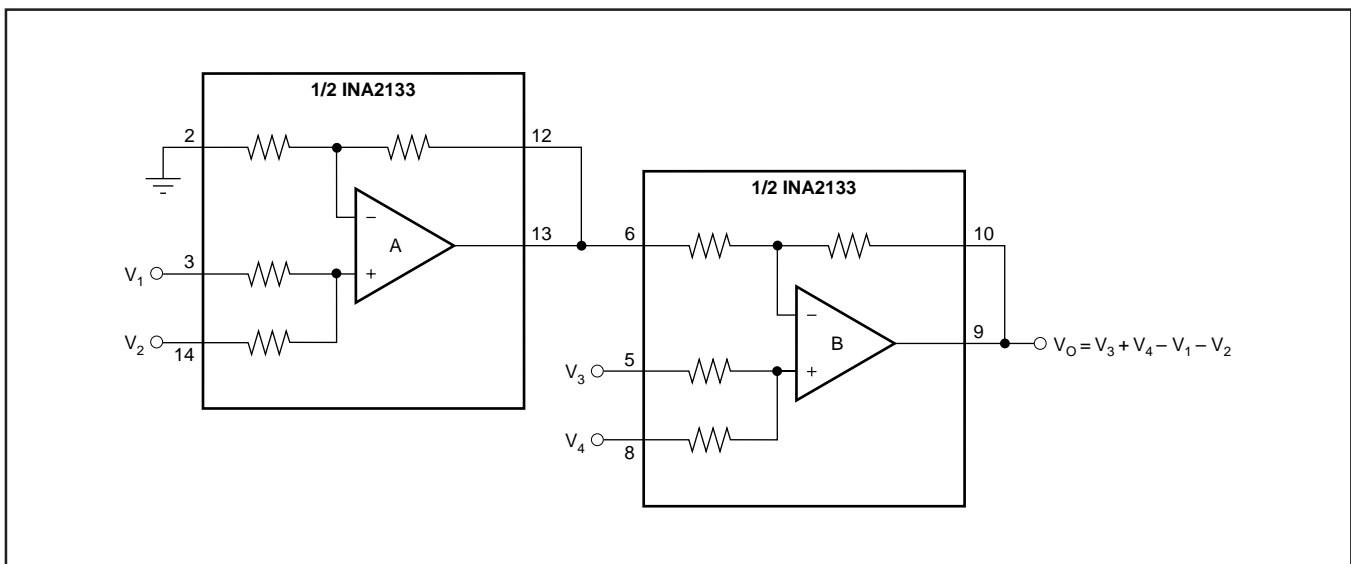

FIGURE 14. Precision Summing Instrumentation Amplifier.

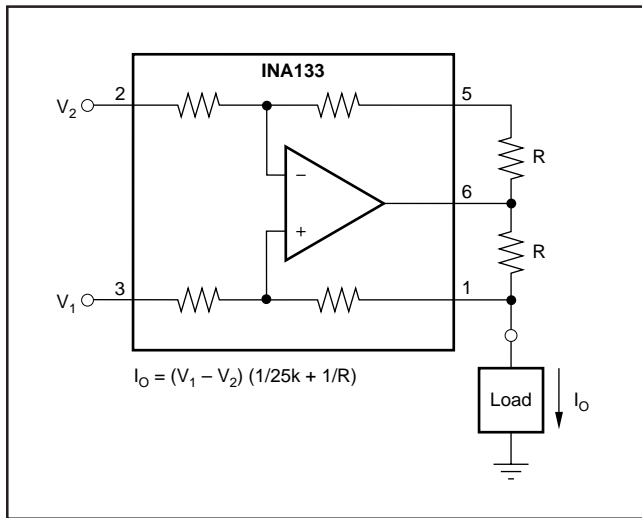

FIGURE 15. Precision Voltage-to-Current Converter with Differential Inputs.

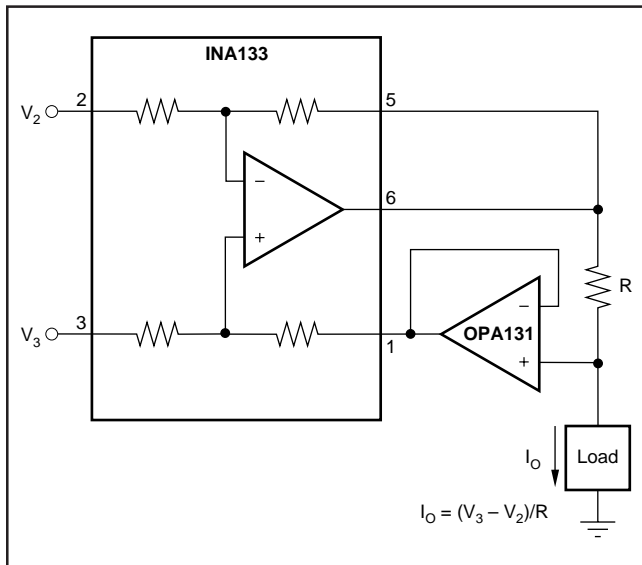

FIGURE 16. Differential Input Voltage-to-Current Converter for Low  $I_{OUT}$ .

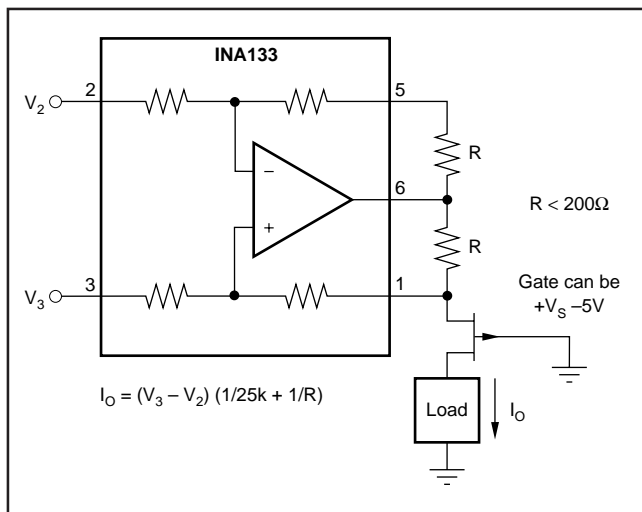

FIGURE 17. Isolating Current Source.

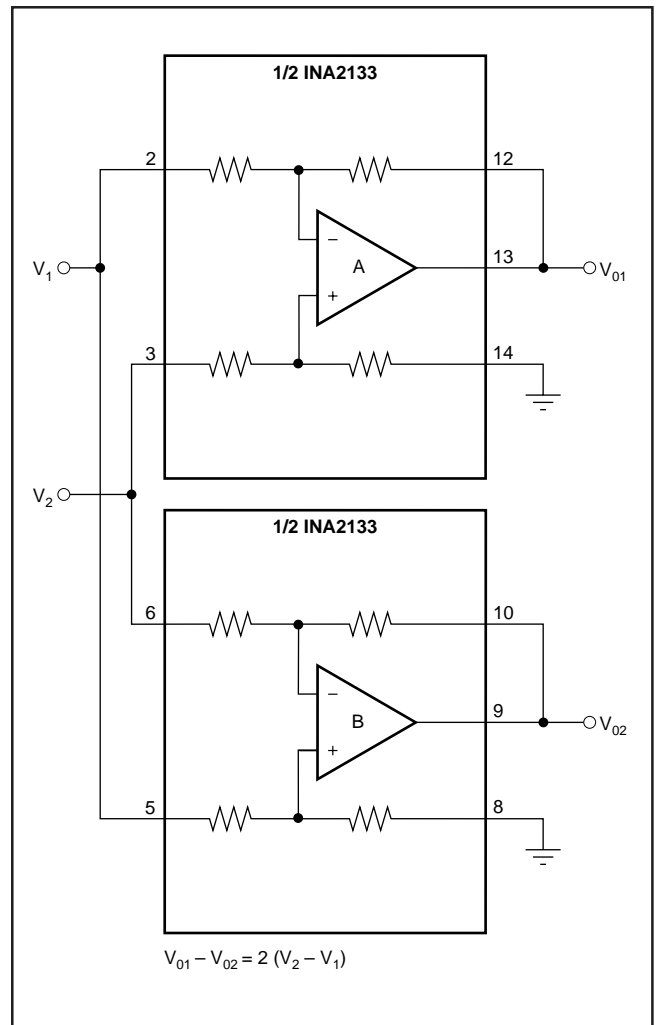

FIGURE 18. Differential Output Difference Amplifier.

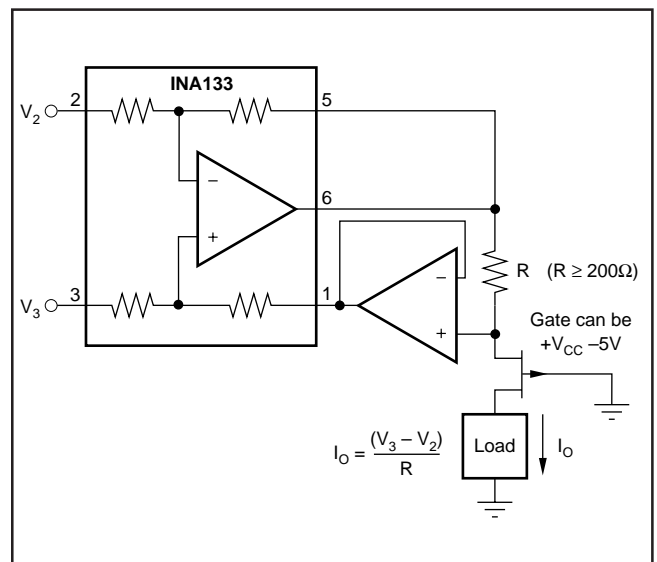

FIGURE 19. Isolating Current Source with Buffering Amplifier for Greater Accuracy.

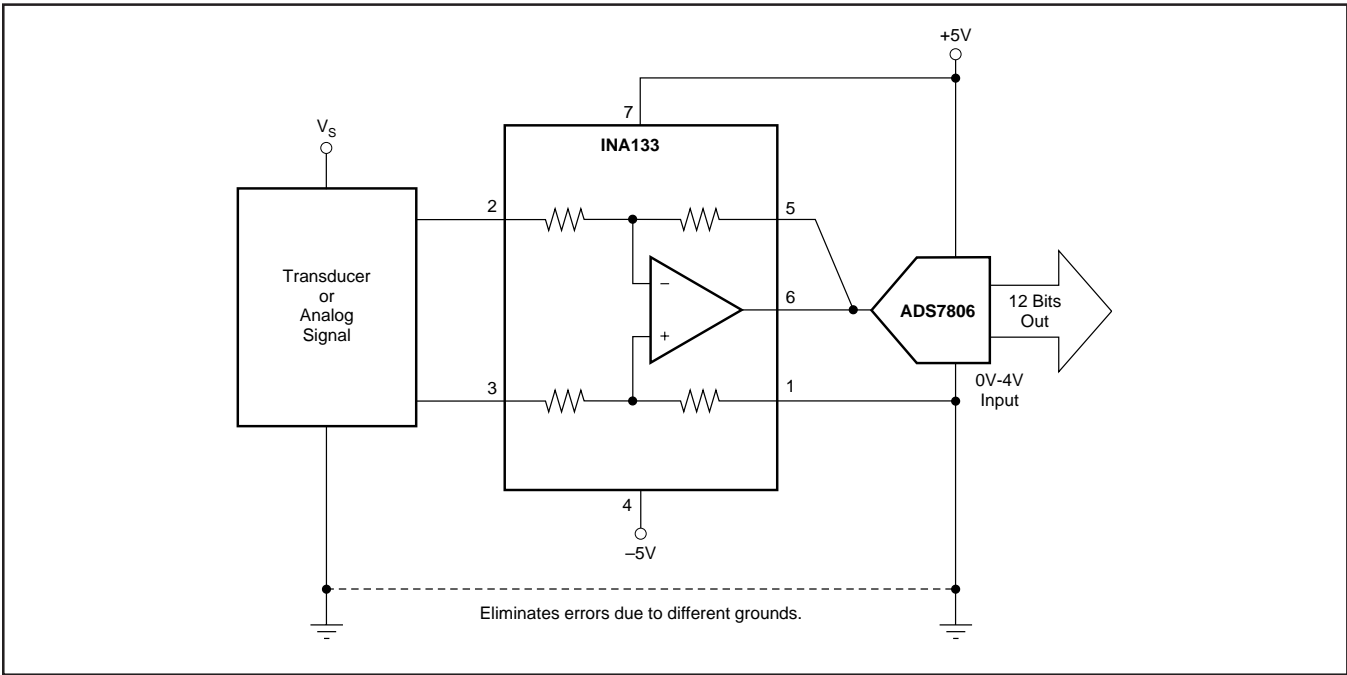

FIGURE 20. Differential Input Data Acquisition.

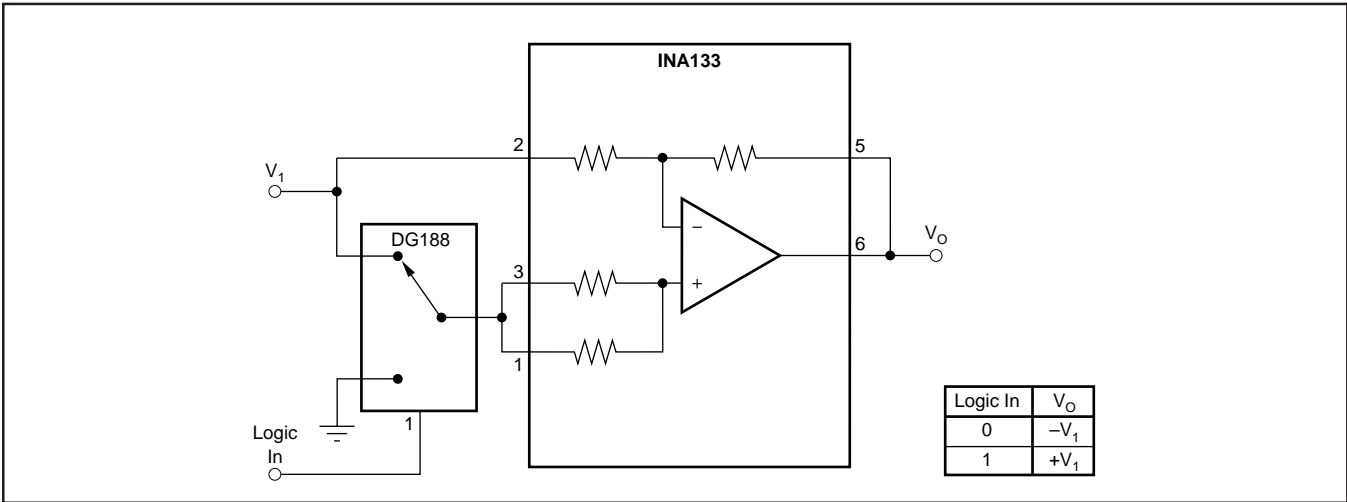

FIGURE 21. Digitally Controlled Gain of ±1 Amplifier.

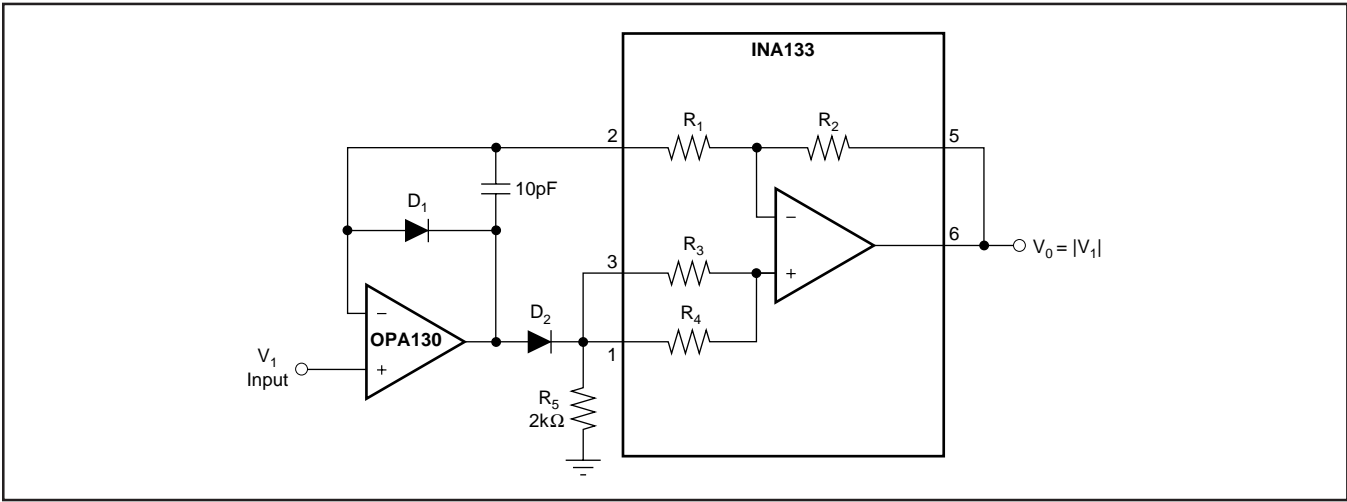

FIGURE 22. Precision Absolute Value Buffer.

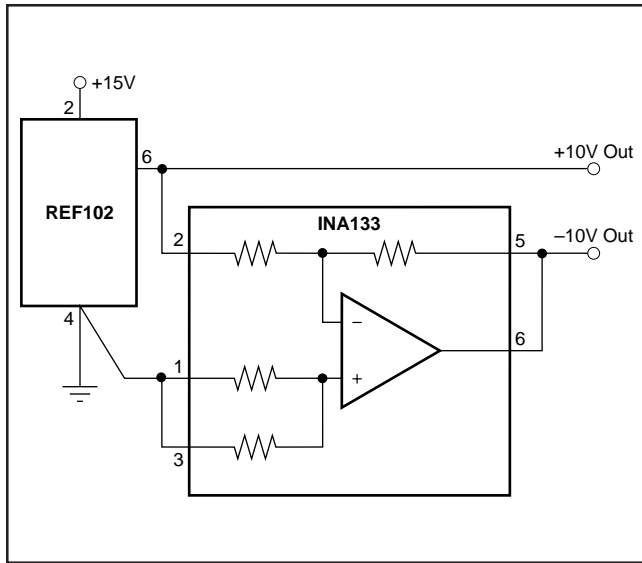

FIGURE 23. ±10V Precision Voltage Reference.

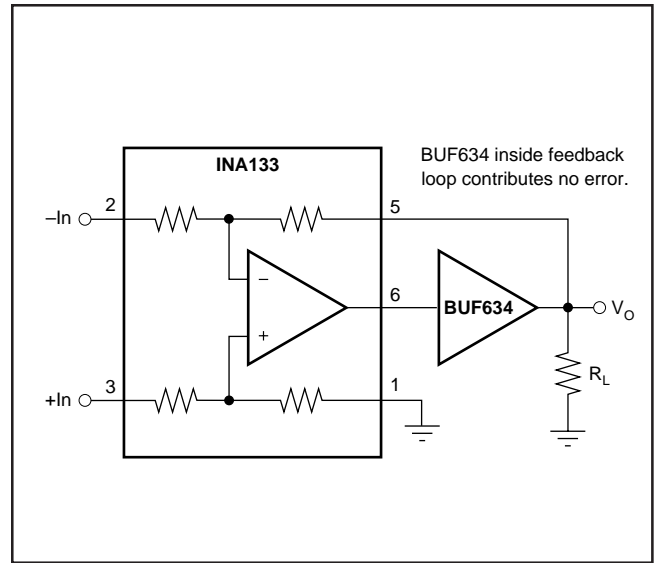

FIGURE 24. High Output Current Precision Difference Amplifier.

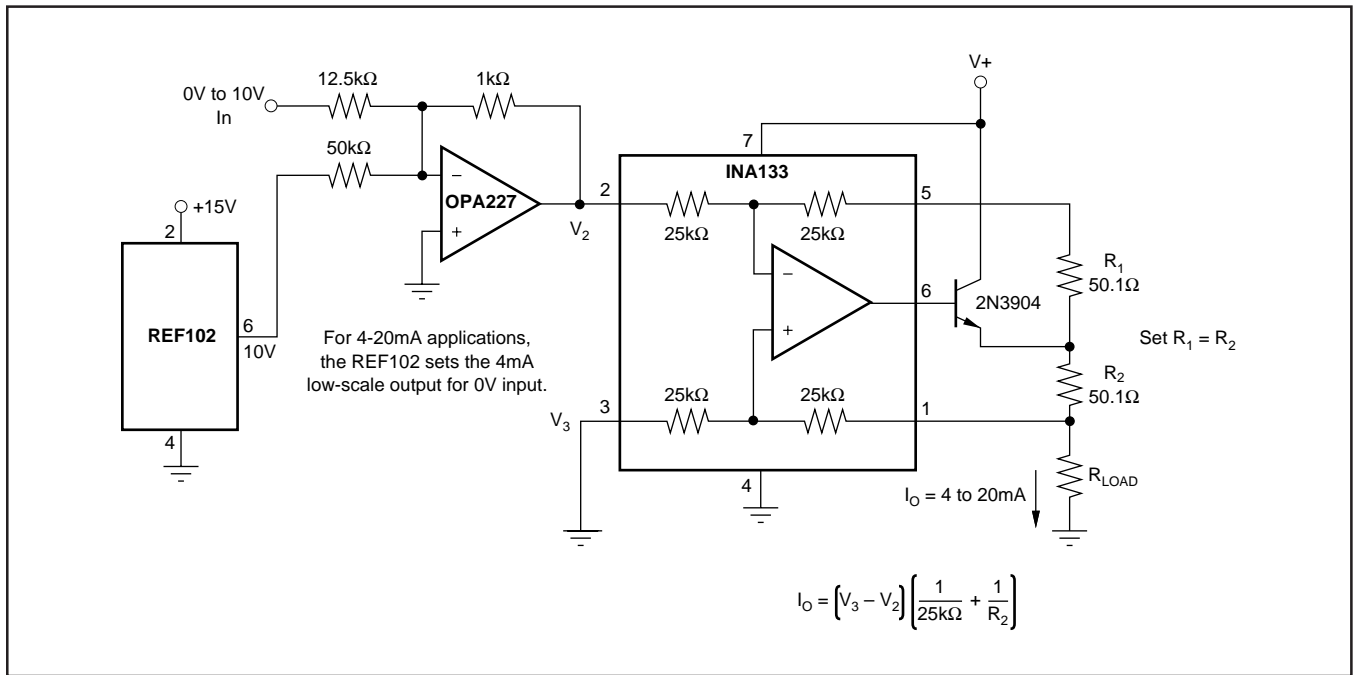

FIGURE 25. Precision Voltage-to-Current Conversion.

**PACKAGING INFORMATION**

Orderable Device	Status <sup>(1)</sup>	Package Type	Package Drawing	Pins	Package Qty	Eco Plan <sup>(2)</sup>	Lead/Ball Finish	MSL Peak Temp <sup>(3)</sup>
INA133U	ACTIVE	SOIC	D	8	75	Green (RoHS & no Sb/Br)	CU NIPDAU	Level-3-260C-168 HR
INA133U/2K5	ACTIVE	SOIC	D	8	2500	Green (RoHS & no Sb/Br)	CU NIPDAU	Level-3-260C-168 HR
INA133U/2K5E4	ACTIVE	SOIC	D	8	2500	Green (RoHS & no Sb/Br)	CU NIPDAU	Level-3-260C-168 HR
INA133UA	ACTIVE	SOIC	D	8	75	Green (RoHS & no Sb/Br)	Call TI	Level-3-260C-168 HR
INA133UA/2K5	ACTIVE	SOIC	D	8	2500	Green (RoHS & no Sb/Br)	CU NIPDAU	Level-3-260C-168 HR
INA133UA/2K5E4	ACTIVE	SOIC	D	8	2500	Green (RoHS & no Sb/Br)	CU NIPDAU	Level-3-260C-168 HR
INA133UAE4	ACTIVE	SOIC	D	8	75	Green (RoHS & no Sb/Br)	Call TI	Level-3-260C-168 HR
INA133UE4	ACTIVE	SOIC	D	8	75	Green (RoHS & no Sb/Br)	CU NIPDAU	Level-3-260C-168 HR
INA2133U	ACTIVE	SOIC	D	14	50	Green (RoHS & no Sb/Br)	CU NIPDAU	Level-3-260C-168 HR
INA2133U/2K5E4	OBSOLETE	SOIC	D	14		TBD	Call TI	Call TI
INA2133UA	ACTIVE	SOIC	D	14	50	Green (RoHS & no Sb/Br)	CU NIPDAU	Level-3-260C-168 HR
INA2133UA/2K5E4	OBSOLETE	SOIC	D	14		TBD	Call TI	Call TI
INA2133UAE4	ACTIVE	SOIC	D	14	50	Green (RoHS & no Sb/Br)	CU NIPDAU	Level-3-260C-168 HR
INA2133UAG4	ACTIVE	SOIC	D	14	50	Green (RoHS & no Sb/Br)	CU NIPDAU	Level-3-260C-168 HR
INA2133UE4	ACTIVE	SOIC	D	14	50	Green (RoHS & no Sb/Br)	CU NIPDAU	Level-3-260C-168 HR
INA2133UG4	ACTIVE	SOIC	D	14	50	Green (RoHS & no Sb/Br)	CU NIPDAU	Level-3-260C-168 HR

<sup>(1)</sup> The marketing status values are defined as follows:

**ACTIVE:** Product device recommended for new designs.

**LIFEBUY:** TI has announced that the device will be discontinued, and a lifetime-buy period is in effect.

**NRND:** Not recommended for new designs. Device is in production to support existing customers, but TI does not recommend using this part in a new design.

**PREVIEW:** Device has been announced but is not in production. Samples may or may not be available.

**OBSOLETE:** TI has discontinued the production of the device.

<sup>(2)</sup> Eco Plan - The planned eco-friendly classification: Pb-Free (RoHS), Pb-Free (RoHS Exempt), or Green (RoHS & no Sb/Br) - please check <http://www.ti.com/productcontent> for the latest availability information and additional product content details.

**TBD:** The Pb-Free/Green conversion plan has not been defined.

**Pb-Free (RoHS):** TI's terms "Lead-Free" or "Pb-Free" mean semiconductor products that are compatible with the current RoHS requirements for all 6 substances, including the requirement that lead not exceed 0.1% by weight in homogeneous materials. Where designed to be soldered at high temperatures, TI Pb-Free products are suitable for use in specified lead-free processes.

**Pb-Free (RoHS Exempt):** This component has a RoHS exemption for either 1) lead-based flip-chip solder bumps used between the die and package, or 2) lead-based die adhesive used between the die and leadframe. The component is otherwise considered Pb-Free (RoHS compatible) as defined above.

**Green (RoHS & no Sb/Br):** TI defines "Green" to mean Pb-Free (RoHS compatible), and free of Bromine (Br) and Antimony (Sb) based flame retardants (Br or Sb do not exceed 0.1% by weight in homogeneous material)

<sup>(3)</sup> MSL, Peak Temp. -- The Moisture Sensitivity Level rating according to the JEDEC industry standard classifications, and peak solder temperature.

**Important Information and Disclaimer:**The information provided on this page represents TI's knowledge and belief as of the date that it is provided. TI bases its knowledge and belief on information provided by third parties, and makes no representation or warranty as to the accuracy of such information. Efforts are underway to better integrate information from third parties. TI has taken and continues to take reasonable steps to provide representative and accurate information but may not have conducted destructive testing or chemical analysis on incoming materials and chemicals. TI and TI suppliers consider certain information to be proprietary, and thus CAS numbers and other limited information may not be available for release.

In no event shall TI's liability arising out of such information exceed the total purchase price of the TI part(s) at issue in this document sold by TI to Customer on an annual basis.

## TAPE AND REEL INFORMATION

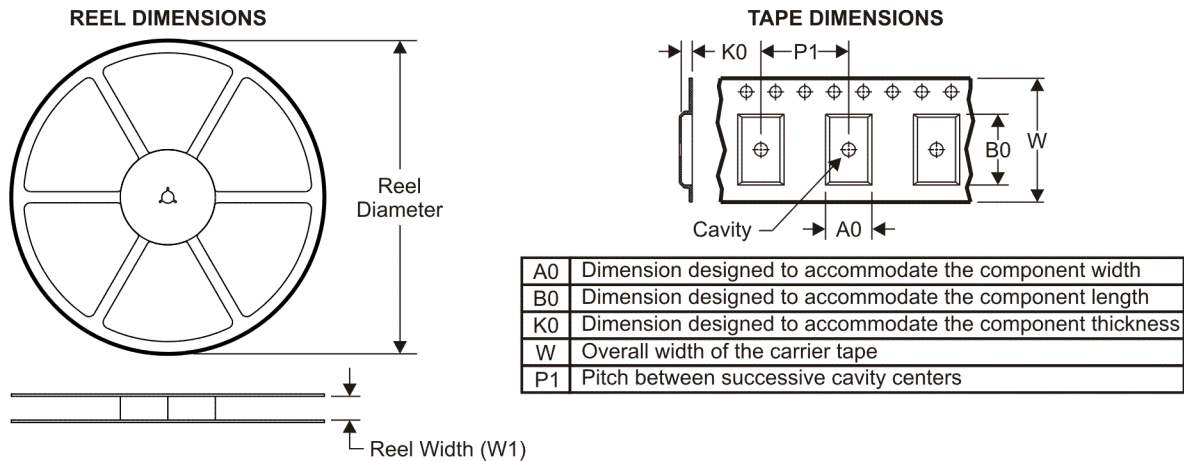

### QUADRANT ASSIGNMENTS FOR PIN 1 ORIENTATION IN TAPE



\*All dimensions are nominal

Device	Package Type	Package Drawing	Pins	SPQ	Reel Diameter (mm)	Reel Width W1 (mm)	A0 (mm)	B0 (mm)	K0 (mm)	P1 (mm)	W (mm)	Pin1 Quadrant
INA133U/2K5	SOIC	D	8	2500	330.0	12.4	6.4	5.2	2.1	8.0	12.0	Q1
INA133UA/2K5	SOIC	D	8	2500	330.0	12.4	6.4	5.2	2.1	8.0	12.0	Q1

**TAPE AND REEL BOX DIMENSIONS**

\*All dimensions are nominal

Device	Package Type	Package Drawing	Pins	SPQ	Length (mm)	Width (mm)	Height (mm)
INA133U/2K5	SOIC	D	8	2500	346.0	346.0	29.0
INA133UA/2K5	SOIC	D	8	2500	346.0	346.0	29.0

## IMPORTANT NOTICE

Texas Instruments Incorporated and its subsidiaries (TI) reserve the right to make corrections, modifications, enhancements, improvements, and other changes to its products and services at any time and to discontinue any product or service without notice. Customers should obtain the latest relevant information before placing orders and should verify that such information is current and complete. All products are sold subject to TI's terms and conditions of sale supplied at the time of order acknowledgment.

TI warrants performance of its hardware products to the specifications applicable at the time of sale in accordance with TI's standard warranty. Testing and other quality control techniques are used to the extent TI deems necessary to support this warranty. Except where mandated by government requirements, testing of all parameters of each product is not necessarily performed.

TI assumes no liability for applications assistance or customer product design. Customers are responsible for their products and applications using TI components. To minimize the risks associated with customer products and applications, customers should provide adequate design and operating safeguards.

TI does not warrant or represent that any license, either express or implied, is granted under any TI patent right, copyright, mask work right, or other TI intellectual property right relating to any combination, machine, or process in which TI products or services are used. Information published by TI regarding third-party products or services does not constitute a license from TI to use such products or services or a warranty or endorsement thereof. Use of such information may require a license from a third party under the patents or other intellectual property of the third party, or a license from TI under the patents or other intellectual property of TI.

Reproduction of TI information in TI data books or data sheets is permissible only if reproduction is without alteration and is accompanied by all associated warranties, conditions, limitations, and notices. Reproduction of this information with alteration is an unfair and deceptive business practice. TI is not responsible or liable for such altered documentation. Information of third parties may be subject to additional restrictions.

Resale of TI products or services with statements different from or beyond the parameters stated by TI for that product or service voids all express and any implied warranties for the associated TI product or service and is an unfair and deceptive business practice. TI is not responsible or liable for any such statements.

TI products are not authorized for use in safety-critical applications (such as life support) where a failure of the TI product would reasonably be expected to cause severe personal injury or death, unless officers of the parties have executed an agreement specifically governing such use. Buyers represent that they have all necessary expertise in the safety and regulatory ramifications of their applications, and acknowledge and agree that they are solely responsible for all legal, regulatory and safety-related requirements concerning their products and any use of TI products in such safety-critical applications, notwithstanding any applications-related information or support that may be provided by TI. Further, Buyers must fully indemnify TI and its representatives against any damages arising out of the use of TI products in such safety-critical applications.

TI products are neither designed nor intended for use in military/aerospace applications or environments unless the TI products are specifically designated by TI as military-grade or "enhanced plastic." Only products designated by TI as military-grade meet military specifications. Buyers acknowledge and agree that any such use of TI products which TI has not designated as military-grade is solely at the Buyer's risk, and that they are solely responsible for compliance with all legal and regulatory requirements in connection with such use.

TI products are neither designed nor intended for use in automotive applications or environments unless the specific TI products are designated by TI as compliant with ISO/TS 16949 requirements. Buyers acknowledge and agree that, if they use any non-designated products in automotive applications, TI will not be responsible for any failure to meet such requirements.

Following are URLs where you can obtain information on other Texas Instruments products and application solutions:

### Products

Amplifiers	<a href="http://amplifier.ti.com">amplifier.ti.com</a>
Data Converters	<a href="http://dataconverter.ti.com">dataconverter.ti.com</a>
DLP® Products	<a href="http://www.dlp.com">www.dlp.com</a>
DSP	<a href="http://dsp.ti.com">dsp.ti.com</a>
Clocks and Timers	<a href="http://www.ti.com/clocks">www.ti.com/clocks</a>
Interface	<a href="http://interface.ti.com">interface.ti.com</a>
Logic	<a href="http://logic.ti.com">logic.ti.com</a>
Power Mgmt	<a href="http://power.ti.com">power.ti.com</a>
Microcontrollers	<a href="http://microcontroller.ti.com">microcontroller.ti.com</a>
RFID	<a href="http://www.ti-rfid.com">www.ti-rfid.com</a>
RF/IF and ZigBee® Solutions	<a href="http://www.ti.com/lprf">www.ti.com/lprf</a>

### Applications

Audio	<a href="http://www.ti.com/audio">www.ti.com/audio</a>
Automotive	<a href="http://www.ti.com/automotive">www.ti.com/automotive</a>
Broadband	<a href="http://www.ti.com/broadband">www.ti.com/broadband</a>
Digital Control	<a href="http://www.ti.com/digitalcontrol">www.ti.com/digitalcontrol</a>
Medical	<a href="http://www.ti.com/medical">www.ti.com/medical</a>
Military	<a href="http://www.ti.com/military">www.ti.com/military</a>
Optical Networking	<a href="http://www.ti.com/opticalnetwork">www.ti.com/opticalnetwork</a>
Security	<a href="http://www.ti.com/security">www.ti.com/security</a>
Telephony	<a href="http://www.ti.com/telephony">www.ti.com/telephony</a>
Video & Imaging	<a href="http://www.ti.com/video">www.ti.com/video</a>
Wireless	<a href="http://www.ti.com/wireless">www.ti.com/wireless</a>

Mailing Address: Texas Instruments, Post Office Box 655303, Dallas, Texas 75265  
Copyright © 2009, Texas Instruments Incorporated

## Looking for pricing, stock, or lifecycle information?

Click below to explore more details on WIN SOURCE:

 [View INA133U/2K5](#) on WIN SOURCE

 [Texas Instruments](#) Information

## Optimize Your Supply Chain with WIN SOURCE Solutions

-  Global Sourcing Solution
-  Obsolete Management
-  Cost Control Management
-  Shortage Management
-  Alternative Solution
-  Excess Inventory Management