



THE DATASHEET OF INA141UA



INA141 Precision, Low-Power, $G = 10$ V/V or 100 V/V Instrumentation Amplifier

1 Features

- Low offset voltage:
 - $50 \mu\text{V}$ maximum at $G = 100$ V/V
- Low drift:
 - $0.5 \mu\text{V}/^\circ\text{C}$ maximum at $G = 100$ V/V
- Accurate gain:
 - $\pm 0.05\%$ at $G = 10$ V/V
- Low input bias current:
 - 5 nA , maximum
- High CMR:
 - 117 dB , minimum
- Inputs protected to $\pm 40 \text{ V}$
- Wide supply range: $\pm 2.25 \text{ V}$ to $\pm 18 \text{ V}$
- Low quiescent current: $750 \mu\text{A}$

2 Applications

- [Temperature transmitter](#)
- [Medical instrumentation](#)
- [Data acquisition \(DAQ\)](#)
- [Process analytics \(pH, gas, concentration, force and humidity\)](#)

3 Description

The INA141 is a low power, general-purpose instrumentation amplifier offering excellent accuracy. The versatile three-op-amp design and small size make this device an excellent choice for a wide range of applications. Current-feedback input circuitry provides wide bandwidth even at high gain (200 kHz at $G = 100$ V/V).

Simple pin connections set an accurate gain of 10 V/V or 100 V/V without external resistors. Internal input protection can withstand up to $\pm 40 \text{ V}$ without damage.

The INA141 is laser trimmed for very low offset voltage ($50 \mu\text{V}$), drift ($0.5 \mu\text{V}/^\circ\text{C}$) and high common-mode rejection (117 dB at $G = 100$ V/V). The device operates with power supplies as low as $\pm 2.25 \text{ V}$, and quiescent current is only $750 \mu\text{A}$.

The INA141 is available in an 8-pin SOIC package, and is specified for the -40°C to $+85^\circ\text{C}$ temperature range.

Package Information

PART NUMBER	PACKAGE ⁽¹⁾	PACKAGE SIZE ⁽²⁾
INA141	D (SOIC, 8)	4.9 mm × 6 mm

(1) For all available packages, see the orderable addendum at the end of the data sheet.

(2) The package size (length × width) is a nominal value and includes pins, where applicable.

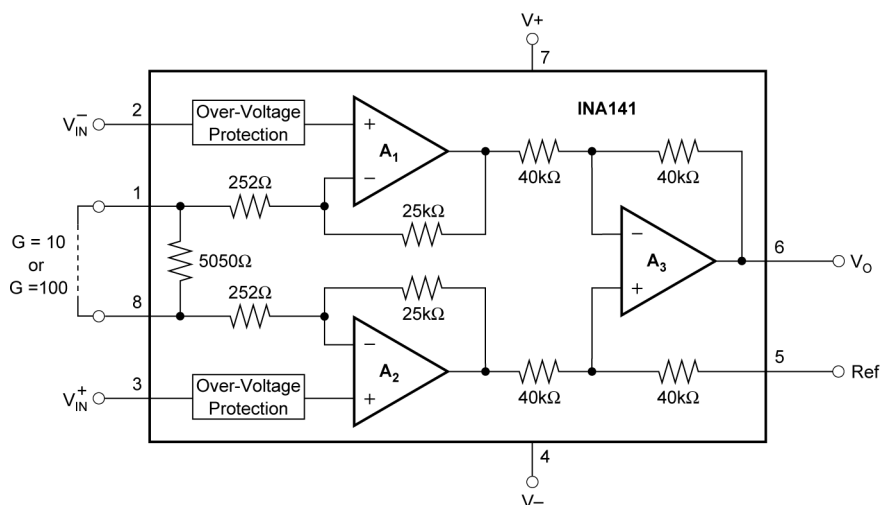

Basic Connections



Table of Contents

1 Features	1	6.6 Typical Characteristics.....	7
2 Applications	1	7 Application and Implementation	11
3 Description	1	7.1 Application Information.....	11
4 Revision History	2	8 Device and Documentation Support	16
5 Pin Configuration and Functions	3	8.1 Receiving Notification of Documentation Updates....	16
6 Specifications	4	8.2 Support Resources.....	16
6.1 Absolute Maximum Ratings.....	4	8.3 Trademarks.....	16
6.2 ESD Ratings	4	8.4 Electrostatic Discharge Caution.....	16
6.3 Recommended Operating Conditions.....	4	8.5 Glossary.....	16
6.4 Thermal Information.....	4	9 Mechanical, Packaging, and Orderable Information..	16
6.5 Electrical Characteristics.....	5		

4 Revision History

NOTE: Page numbers for previous revisions may differ from page numbers in the current version.

Changes from Revision * (September 2000) to Revision A (August 2023)

Page

• Updated the numbering format for tables, figures, and cross-references throughout the document.....	1
• Added the <i>Package Information table</i> , and the <i>Pin Configuration and Functions</i> , <i>Specifications</i> , <i>ESD Ratings</i> , <i>Recommended Operating Conditions</i> , <i>Thermal Information</i> , <i>Application and Implementation</i> , <i>Device and Documentation Support</i> , and <i>Mechanical, Packaging, and Orderable Information</i> sections.....	1
• Deleted PDIP package from data sheet.....	1
• Added single supply specification to Absolute Maximum Ratings.....	4
• Added note that output short-circuit (to ground) means short-circuit to $V_S/2$ in Absolute Maximum Ratings....	4
• Added "TA = –40°C to +85°C" test condition to Offset voltage vs temperature specification in the Electrical Characteristics and renamed to Offset voltage drift.....	5
• Added test conditions "VREF = 0 V, VCM = VS / 2 and G = 10 below the title.....	5
• Deleted common-mode voltage typical values in the Electrical Characteristics and combined to one line.....	5
• Added "TA = –40°C to +85°C" test condition to Bias current vs temperature specification in the Electrical Characteristics and renamed to Input bias current drift for clarity.....	5
• Added "TA = –40°C to +85°C" test condition to Offset current vs temperature specification in Electrical Characteristics and renamed to Input offset current drift for clarity.....	5
• Added "TA = –40°C to +85°C" test condition for Gain error vs temperature in the Electrical Characteristics and renamed to Gain drift for clarity.....	5
• Changed parameter names from "Voltage - Positive" and "Voltage - Negative" to "Output voltage" in the Electrical Characteristics.....	5
• Added "Continuous to VS / 2" test condition short-circuit current specification in the Electrical Characteristics for clarity.....	5
• Changed short-circuit current typical value from +6/-15 mA ±20 mA.....	5
• Changed bandwidth typical value from 1 MHz to 610 kHz in the Electrical Characteristics.....	5
• Changed slew rate typical value from 4 V/μs to 2 V/μs in the Electrical Characteristics.....	5
• Deleted redundant voltage range, operating temperature range, and specification temperature range specifications from Electrical Characteristics.....	5
• Changed Figure 6-2, <i>Common-Mode Rejection vs Frequency</i>	7
• Changed Figure 6-8, <i>Quiescent Current and Slew Rate vs Temperature</i>	7
• Changed <i>Output Voltage Swing vs Output Current</i> single plot to Figure 6-12, <i>Positive Output Voltage Swing vs Output Current</i> and Figure 6-12, <i>Negative Output Voltage Swing vs Output Current</i>	7
• Changed Figure 6-18, <i>Small-Signal Step Response</i>	7
• Changed Figure 6-19, <i>Large-Signal Step Response</i>	7
• Changed Figure 6-20, <i>0.1-Hz to 10-Hz Input-Referred Voltage Noise</i>	7
• Changed G from 1 to 10 V/V at the end of the <i>Application Information</i> section.....	11
• Deleted reference to <i>Input Bias Current vs Common-Mode Input Voltage</i> plot.....	13

5 Pin Configuration and Functions

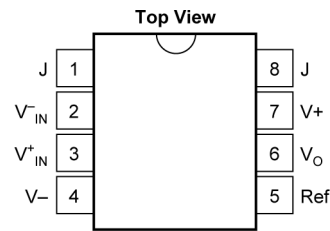

Figure 5-1. D Package, 8-Pin SOIC (Top View)

Table 5-1. Pin Functions

PIN		TYPE	DESCRIPTION
NAME	NO.		
J	1, 8	Input	Gain selection. G = 10 V/V if not shorted G = 100 V/V if shorted A resistance of 0.5 Ω decreases gain by 0.1%.
Ref	5	Input	Reference input. This pin must be driven by low impedance
V-	4	—	Negative supply
V+	7	—	Positive supply
V _{IN} ⁻	2	Input	Negative (inverting) input
V _{IN} ⁺	3	Input	Positive (noninverting) input
V _O	6	Output	Output

6 Specifications

6.1 Absolute Maximum Ratings

over operating free-air temperature range (unless otherwise noted)⁽¹⁾

			MIN	MAX	UNIT
V _S	Supply voltage	Dual supply, V _S = (V+) – (V–)		±18	V
		Single supply, V _S = (V+) – 0 V		36	
	Input voltage			±40	V
	Output short-circuit (to ground) ⁽²⁾		Continuous		
T _A	Operating temperature		–40	125	°C
T _{stg}	Storage temperature		–40	125	°C
T _J	Junction temperature			150	°C
	Lead temperature (soldering, 10 s)			300	°C

- (1) Operation outside the Absolute Maximum Ratings may cause permanent device damage. Absolute Maximum Ratings do not imply functional operation of the device at these or any other conditions beyond those listed under Recommended Operating Conditions. If used outside the Recommended Operating Conditions but within the Absolute Maximum Ratings, the device may not be fully functional, and this may affect device reliability, functionality, performance, and shorten the device lifetime.
- (2) Short-circuit to V_S / 2.

6.2 ESD Ratings

			VALUE	UNIT
V _(ESD)	Electrostatic discharge	Human-body model (HBM), per ANSI/ESDA/JEDEC JS-001 ⁽¹⁾	±2000	V
		Charged-device model (CDM), per ANSI/ESDA/JEDEC JS-002 ⁽²⁾	±250	

- (1) JEDEC document JEP155 states that 500-V HBM allows safe manufacturing with a standard ESD control process.
- (2) JEDEC document JEP157 states that 250-V CDM allows safe manufacturing with a standard ESD control process.

6.3 Recommended Operating Conditions

over operating free-air temperature range (unless otherwise noted)

			MIN	TYP	MAX	UNIT
V _S	Supply voltage	Single-supply	4.5	30	36	V
		Dual-supply	±2.25	±15	±18	
T _A	Specified temperature		–40		85	°C

6.4 Thermal Information

THERMAL METRIC ⁽¹⁾		INA141	UNIT
		D (SOIC)	
		8 PINS	
θ _{JA}	Junction-to-ambient thermal resistance	150	°C/W
R _{θJA}	Junction-to-ambient thermal resistance	110	°C/W
R _{θJC(top)}	Junction-to-case (top) thermal resistance	57	°C/W
R _{θJB}	Junction-to-board thermal resistance	54	°C/W
ψ _{JT}	Junction-to-top characterization parameter	11	°C/W
ψ _{JB}	Junction-to-board characterization parameter	53	°C/W

- (1) For more information about traditional and new thermal metrics, see the [Semiconductor and IC Package Thermal Metrics](#) application report.

6.5 Electrical Characteristics

at $T_A = 25^\circ\text{C}$, $V_S = \pm 15\text{ V}$, $R_L = 10\text{ k}\Omega$, $V_{REF} = 0\text{ V}$, $V_{CM} = V_S / 2$, and $G = 10\text{ V/V}$ (unless otherwise noted)

PARAMETER		TEST CONDITIONS		MIN	TYP	MAX	UNIT	
INPUT								
V_{OS}	Offset voltage (RTI)	INA141P, INA141U	G = 10 V/V		± 50	± 100	μV	
			G = 100 V/V		± 20	± 50		
		INA141PA, INA141UA	G = 10 V/V		± 50	± 250		
			G = 100 V/V		± 20	± 125		
	Offset voltage drift (RTI)	$T_A = -40^\circ\text{C}$ to $+85^\circ\text{C}$	INA141P, INA141U	G = 10 V/V		± 0.5	± 2	$\mu\text{V}/^\circ\text{C}$
				G = 100 V/V		± 0.2	± 0.5	
			INA141PA, INA141UA	G = 10 V/V		± 0.5	± 2.5	
				G = 100 V/V		± 0.2	± 1.5	
PSRR	Power-supply rejection ratio (RTI)	$V_S = \pm 2.25\text{ V}$ to $\pm 18\text{ V}$	INA141P, INA141U	G = 10 V/V		± 2	± 10	$\mu\text{V/V}$
				G = 100 V/V		± 0.4	± 1	
			INA141PA, INA141UA	G = 10 V/V		± 2	± 20	
				G = 100 V/V		± 0.4	± 3	
	Long-term stability	G = 10 V/V		0.5		$\mu\text{V}/\text{mo}$		
		G = 100 V/V		0.2		$\mu\text{V}/\text{mo}$		
	Input impedance	Differential		100 2		$\text{G}\Omega$ pF		
		Common-mode		100 9				
V_{CM}	Common-mode voltage ⁽¹⁾	$V_O = 0\text{ V}$		$(V-) + 2$		$(V+) - 2$	V	
CMRR	Common-mode rejection	$V_{CM} = \pm 13\text{ V}$, $\Delta R_S = 1\text{ k}\Omega$	INA141P, INA141U	G = 10 V/V		100	106	dB
				G = 100 V/V		117	125	
			INA141PA, INA141UA	G = 10 V/V		93	100	
				G = 100 V/V		110	120	
INPUT BIAS CURRENT								
I_B	Input bias current	INA141P, INA141U		± 2	± 5	nA		
		INA141PA, INA141UA		± 2	± 10			
	Input bias current drift	$T_A = -40^\circ\text{C}$ to $+85^\circ\text{C}$		± 30		$\text{pA}/^\circ\text{C}$		
I_{OS}	Input offset current	INA141P, INA141U		± 1	± 5	nA		
		INA141PA, INA141UA		± 1	± 10	nA		
	Input offset current drift	$T_A = -40^\circ\text{C}$ to $+85^\circ\text{C}$		± 30		$\text{pA}/^\circ\text{C}$		
NOISE								
e_N	Voltage noise (RTI)	$R_S = 0\ \Omega$	G = 10 V/V	f = 10 Hz		22		$\text{nV}/\sqrt{\text{Hz}}$
				f = 100 Hz		13		
				f = 1 kHz		12		
				$f_B = 0.1\text{ Hz}$ to 10 Hz		0.6		
			G = 100 V/V	f = 10 Hz		10		$\text{nV}/\sqrt{\text{Hz}}$
				f = 100 Hz		8		
				f = 1 kHz		8		
				$f_B = 0.1\text{ Hz}$ to 10 Hz		0.2		
I_n	Current noise	f = 10 Hz		0.9		$\text{pA}/\sqrt{\text{Hz}}$		
		f = 1 kHz		0.3				
		$f_B = 0.1\text{ Hz}$ to 10 Hz		30			pA_{PP}	

6.5 Electrical Characteristics (continued)

at $T_A = 25^\circ\text{C}$, $V_S = \pm 15\text{ V}$, $R_L = 10\text{ k}\Omega$, $V_{REF} = 0\text{ V}$, $V_{CM} = V_S / 2$, and $G = 10\text{ V/V}$ (unless otherwise noted)

PARAMETER		TEST CONDITIONS		MIN	TYP	MAX	UNIT
GAIN							
G	Gain			10		100	V/V
GE	Gain error	$V_O = \pm 13.6\text{ V}$	INA141P, INA141U	G = 10 V/V	± 0.01	± 0.05	%
				G = 100 V/V	± 0.03	± 0.075	
			INA141PA, INA141UA	G = 10 V/V	± 0.01	± 0.15	
				G = 100 V/V	± 0.03	± 0.15	
	Gain drift ⁽⁶⁾	G = 10 V/V or 100 V/V, $T_A = -40^\circ\text{C}$ to $+85^\circ\text{C}$			± 2	± 10	ppm/ $^\circ\text{C}$
	Gain nonlinearity	INA141P, INA141U INA141PA, INA141UA	G = 10 V/V	± 0.0003	± 0.001	% of FSR	
				G = 100 V/V	± 0.0005		± 0.002
			G = 10 V/V	± 0.0003	± 0.002		
				G = 100 V/V	± 0.0005		± 0.004
OUTPUT							
	Output voltage			$(V_-) + 1.4$	$(V_{\pm}) \mp 0.9$	$(V_+) - 1.4$	V
C_L	Load capacitance	Stable operation			1000		pF
I_{SC}	Short-circuit current	Continuous to $V_S / 2$			± 20		mA
FREQUENCY RESPONSE							
BW	Bandwidth, -3 dB	G = 10 V/V			610		kHz
		G = 100 V/V			200		
SR	Slew rate	G = 10 V/V, $V_O = \pm 10\text{ V}$			2		V/ μs
t_s	Settling time	T_o 0.01%, $V_O = \pm 5\text{ V}$	G = 10 V/V		7		μs
			G = 100 V/V		9		
	Overload recovery	50% input overload			4		μs
POWER SUPPLY							
I_Q	Quiescent current	$V_{IN} = 0\text{ V}$			± 750	± 800	μA

- (1) Input common-mode voltage varies with output voltage; see *Typical Characteristics*.
(2) Specified by wafer test.

6.6 Typical Characteristics

at $T_A = 25^\circ\text{C}$, $V_S = \pm 15\text{ V}$, $V_{\text{REF}} = 0\text{ V}$, $G = 10\text{ V/V}$, $V_{\text{CM}} = V_S / 2$, and $R_L = 10\text{ k}\Omega$ (unless otherwise noted)

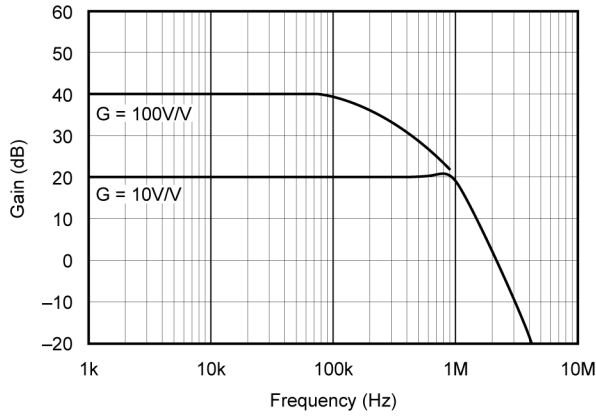

Figure 6-1. Gain vs Frequency

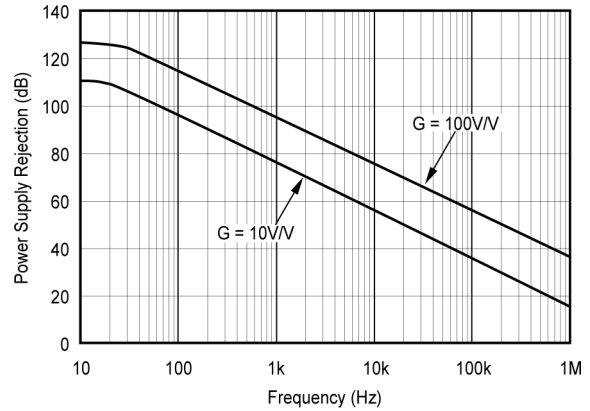

Figure 6-2. Common-Mode Rejection vs Frequency

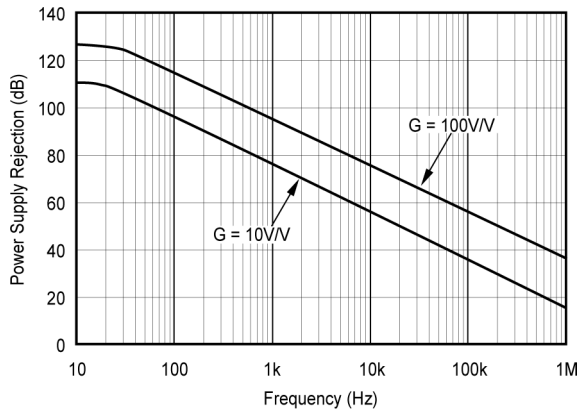

Figure 6-3. Positive Power Supply Rejection vs Frequency

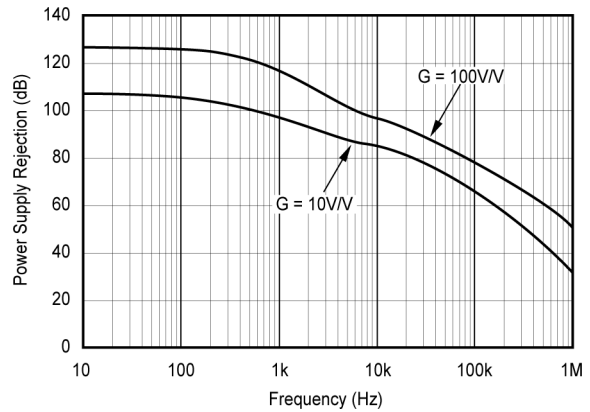

Figure 6-4. Negative Power Supply Rejection vs Frequency

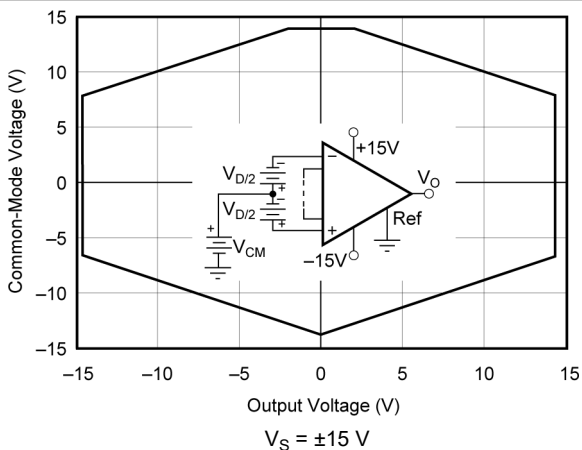

Figure 6-5. Input Common-Mode Range vs Output Voltage

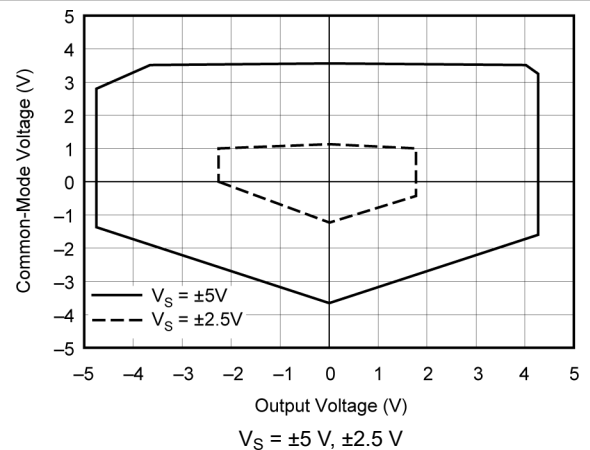

Figure 6-6. Input Common-Mode Range vs Output Voltage

6.6 Typical Characteristics (continued)

at $T_A = 25^\circ\text{C}$, $V_S = \pm 15\text{ V}$, $V_{REF} = 0\text{ V}$, $G = 10\text{ V/V}$, $V_{CM} = V_S / 2$, and $R_L = 10\text{ k}\Omega$ (unless otherwise noted)

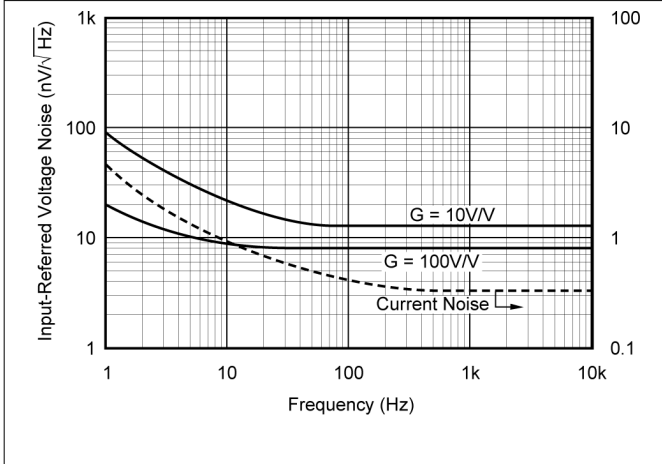

Figure 6-7. Input-Referred Noise vs Frequency

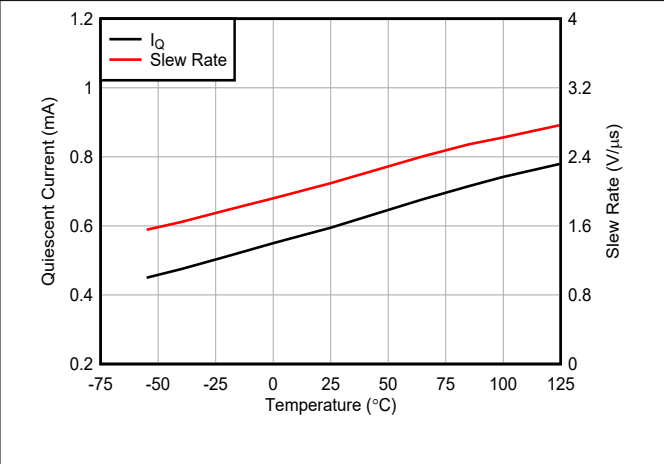

Figure 6-8. Quiescent Current and Slew Rate vs Temperature

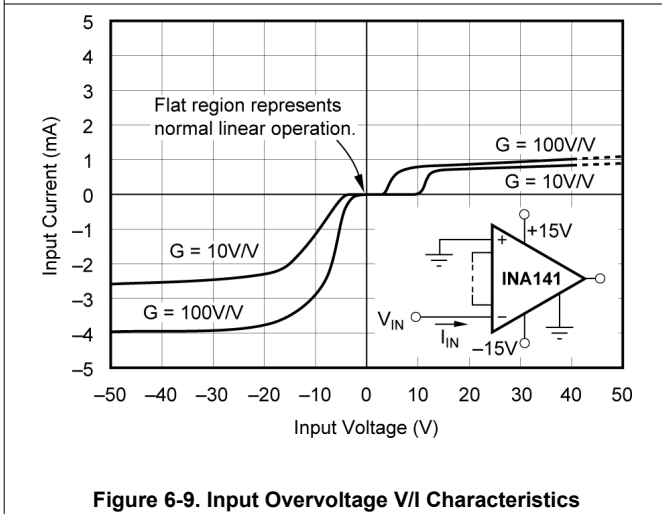

Figure 6-9. Input Overtolerance V/I Characteristics

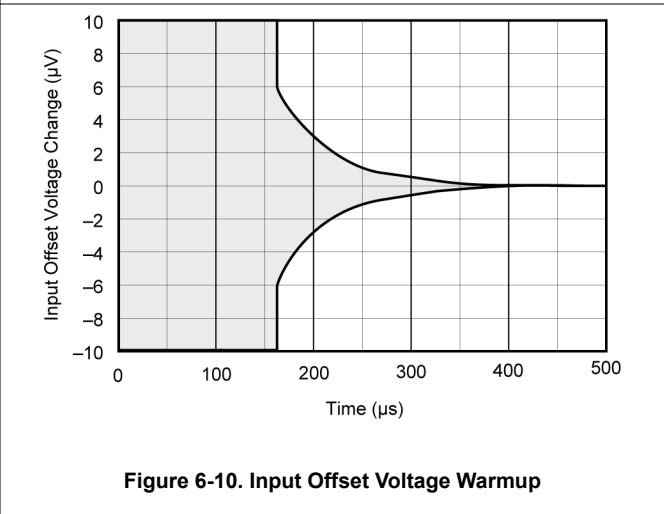

Figure 6-10. Input Offset Voltage Warmup

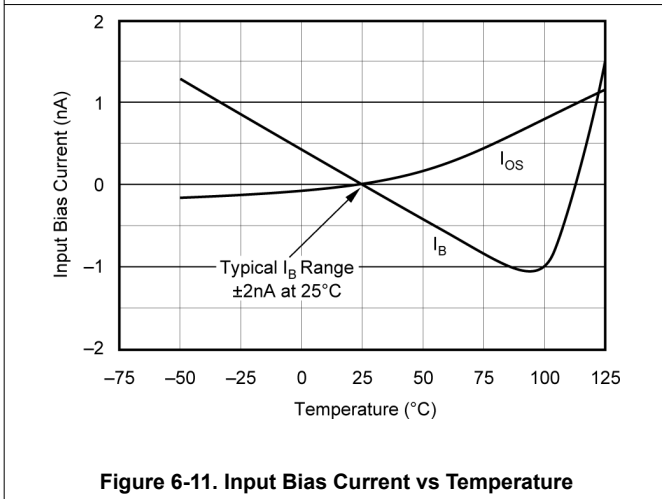

Figure 6-11. Input Bias Current vs Temperature

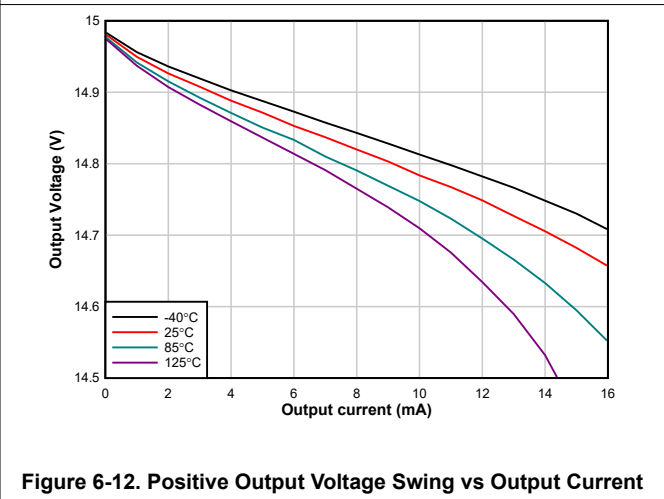

Figure 6-12. Positive Output Voltage Swing vs Output Current

6.6 Typical Characteristics (continued)

at $T_A = 25^\circ\text{C}$, $V_S = \pm 15\text{ V}$, $V_{\text{REF}} = 0\text{ V}$, $G = 10\text{ V/V}$, $V_{\text{CM}} = V_S / 2$, and $R_L = 10\text{ k}\Omega$ (unless otherwise noted)

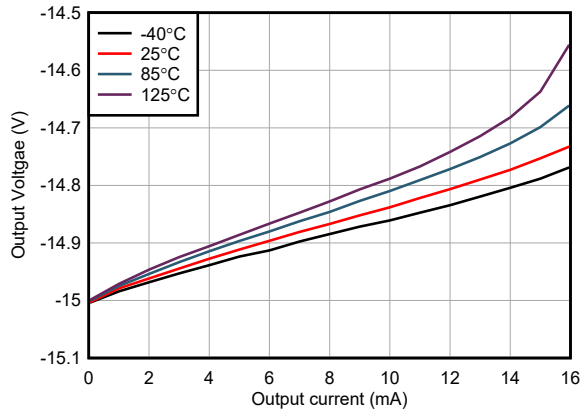

Figure 6-13. Negative Output Voltage Swing vs Output Current

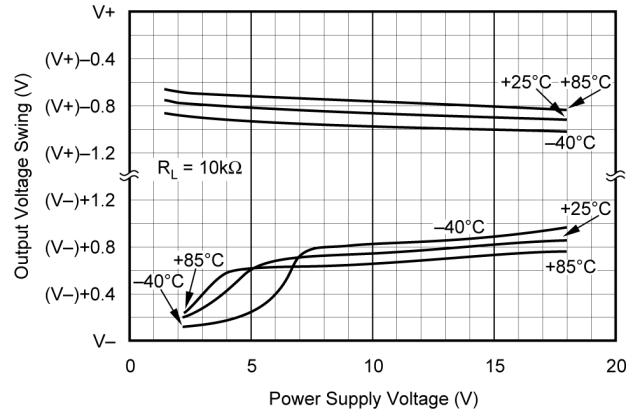

Figure 6-14. Output Voltage Swing vs Power Supply Voltage

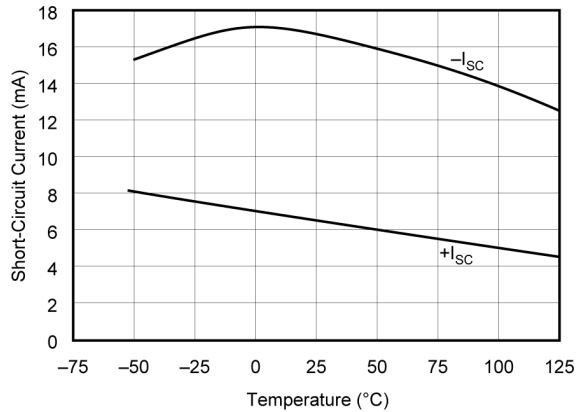

Figure 6-15. Short-circuit Output Current vs Temperature

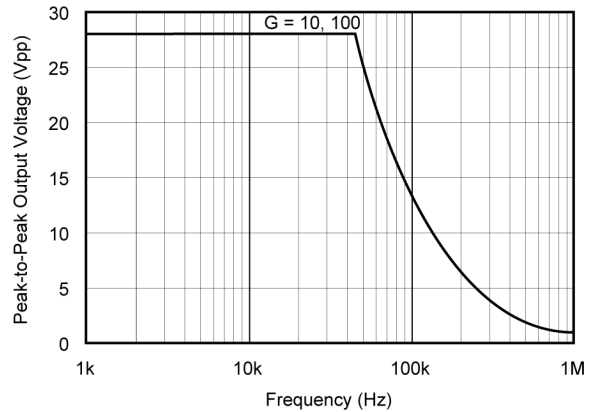

Figure 6-16. Maximum Output Voltage vs Frequency

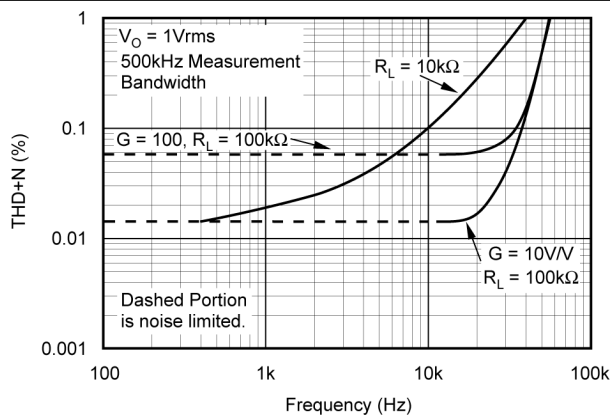

Figure 6-17. Total Harmonic Distortion + Noise vs Frequency

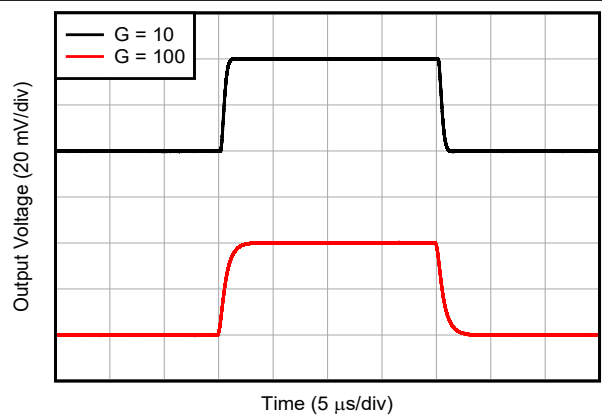

Figure 6-18. Small-Signal Step Response

6.6 Typical Characteristics (continued)

at $T_A = 25^\circ\text{C}$, $V_S = \pm 15\text{ V}$, $V_{\text{REF}} = 0\text{ V}$, $G = 10\text{ V/V}$, $V_{\text{CM}} = V_S / 2$, and $R_L = 10\text{ k}\Omega$ (unless otherwise noted)

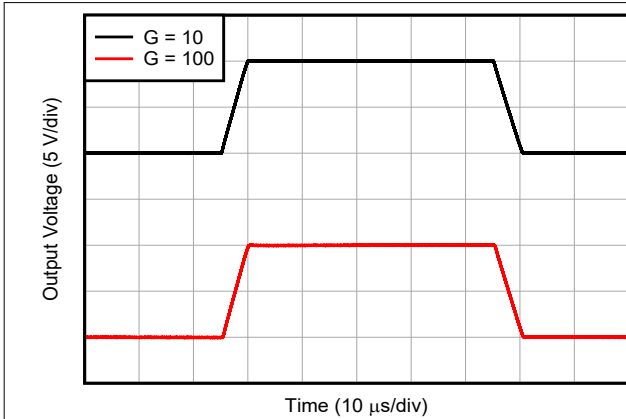

Figure 6-19. Large-Signal Step Response

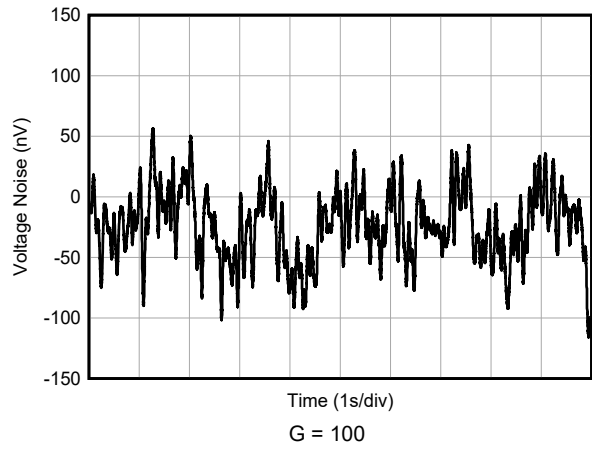

Figure 6-20. 0.1-Hz to 10-Hz Input-Referred Voltage Noise

7 Application and Implementation

Note

Information in the following applications sections is not part of the TI component specification, and TI does not warrant its accuracy or completeness. TI's customers are responsible for determining suitability of components for their purposes, as well as validating and testing their design implementation to confirm system functionality.

7.1 Application Information

Figure 7-1 shows the basic connections required for operation of the INA141. Applications with noisy or high impedance power supplies can require decoupling capacitors close to the device pins as shown.

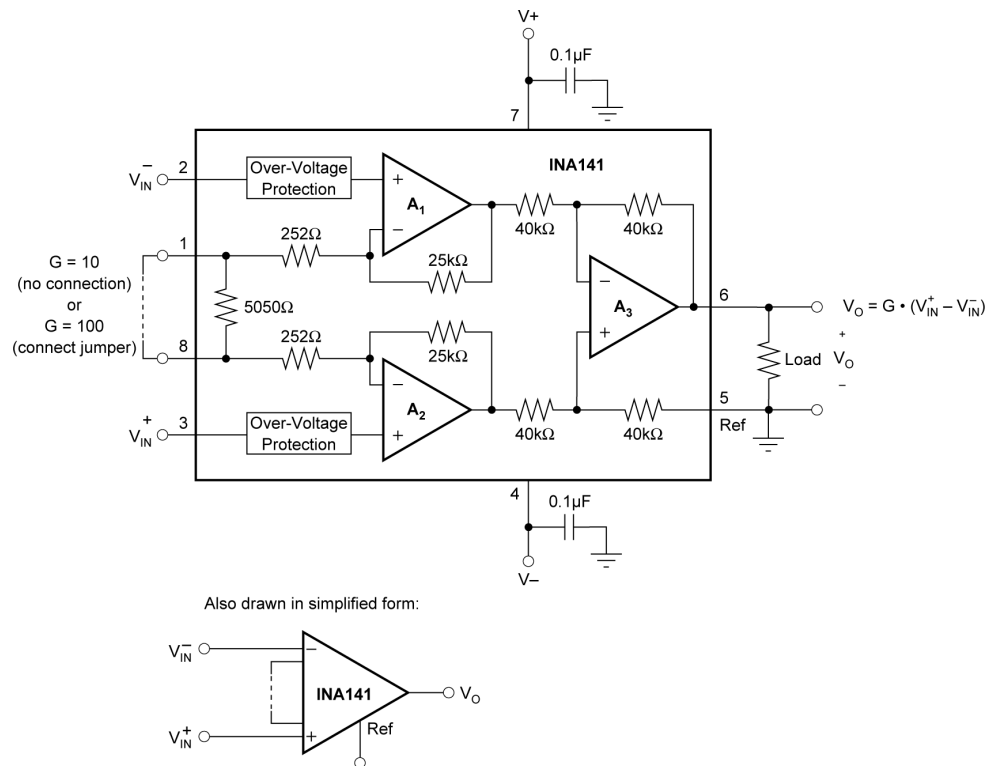

Figure 7-1. Basic Connections.

The output is referred to the output reference (Ref) pin, which is normally grounded. This connection must be low-impedance to maintain good common-mode rejection. A resistance of 8 Ω in series with the Ref pin causes a typical device to degrade to approximately 80 dB CMR ($G = 10$ V/V).

7.1.1 Setting the Gain

Gain is selected with a jumper connection (see Figure 7-1). With no jumper installed, $G = 10$ V/V. With a jumper installed, $G = 100$ V/V. To preserve good gain accuracy, this jumper must have low series resistance. A resistance of 0.5 Ω in series with the jumper decreases the gain by 0.1%.

Internal resistor ratios are laser trimmed to provide excellent gain accuracy. Actual resistor values can vary by approximately $\pm 25\%$ from the nominal values shown.

Gains between 10 V/V and 100 V/V are achieved by connecting an external resistor to the jumper pins. However, this configuration is not recommended because the $\pm 25\%$ variation of internal resistor values makes the required external resistor value uncertain. A companion model, the INA128, features accurately trimmed internal resistors so that gains from 1 V/V to 10,000 V/V can be set with an external resistor.

7.1.2 Dynamic Performance

Typical performance curve *Gain vs Frequency* (Figure 6-1) shows that, despite the low quiescent current, the INA141 achieves wide bandwidth, even at $G = 100$ V/V. This wide bandwidth is a result of the current-feedback topology of the INA141. Settling time also remains excellent at $G = 100$ V/V.

7.1.3 Noise Performance

The INA141 provides very low noise in most applications. Low-frequency noise is approximately $0.2 \mu\text{V}_{\text{PP}}$ measured from 0.1 Hz to 10 Hz ($G = 100$ V/V). The INA141 provides dramatically improved noise when compared to state-of-the-art, chopper-stabilized amplifiers.

7.1.4 Offset Trimming

The INA141 is laser trimmed for low offset voltage and offset voltage drift. Most applications require no external offset adjustment. Figure 7-2 shows an optional circuit for trimming the output offset voltage. The voltage applied to Ref pin is summed with the output. The op-amp buffer provides low impedance at the Ref pin to preserve good common-mode rejection.

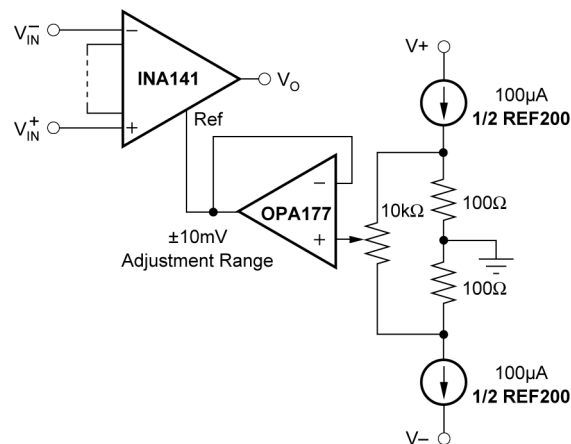

Figure 7-2. Optional Trimming of Output Offset Voltage.

7.1.5 Input Bias Current Return Path

The input impedance of the INA141 is extremely high—approximately $10^{10} \Omega$. However, a path must be provided for the input bias current of both inputs. This input bias current is approximately ± 2 nA. High input impedance means that this input bias current changes very little with varying input voltage.

Input circuitry must provide a path for this input bias current for proper operation. Figure 7-3 shows various provisions for an input bias current path. Without a bias current path, the inputs float to a potential that exceeds the common-mode range of the INA141 and the input amplifiers saturate.

If the differential source resistance is low, the bias current return path can be connected to one input (see the thermocouple example in Figure 7-3). With higher source impedance, using two equal resistors provides a balanced input with possible advantages of lower input offset voltage due to bias current and better high-frequency common-mode rejection.

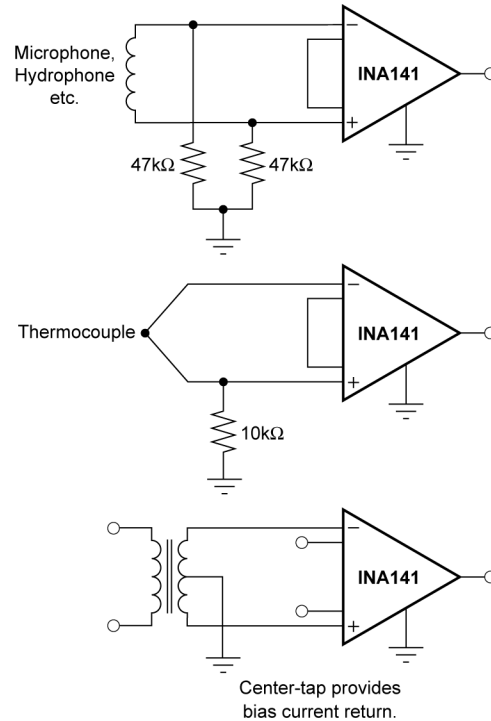

Figure 7-3. Providing an Input Common-Mode Current Path.

7.1.6 Input Common-Mode Range

The linear input voltage range of the input circuitry of the INA141 is from approximately 1.4 V less than the positive supply voltage to 1.7 V greater than the negative supply. As a differential input voltage causes the output voltage to increase, however, the linear input range is limited by the output voltage swing of amplifiers A₁ and A₂. Therefore, the linear common-mode input range is related to the output voltage of the complete amplifier. This behavior also depends on supply voltage (see the *Input Common-Mode Range vs Output Voltage* plots, [Figure 6-5](#) and [Figure 6-6](#)).

Input overload can produce an output voltage that appears normal. For example, if an input overload condition drives both input amplifiers to the positive output swing limit, the difference voltage measured by the output amplifier is near zero. The output of the INA141 is near 0 V even though both inputs are overloaded.

7.1.7 Low-Voltage Operation

The INA141 operates on power supplies as low as ±2.25V. Performance remains excellent with power supplies ranging from ±2.25 V to ±18 V. Most parameters vary only slightly through this supply voltage range—see Typical Performance Curves. Operation at a very low supply voltage requires careful attention to make sure that the input voltages remain within the linear range. Voltage swing requirements of internal nodes limit the input common-mode range with low power-supply voltage. The *Input Common-Mode Range vs Output Voltage* typical characteristics plots, [Figure 6-5](#) and [Figure 6-6](#), show the range of linear operation for ±15-V, ±5-V, and ±2.5-V supplies.

7.1.8 Input Protection

The inputs of the INA141 are individually protected for voltages up to ±40 V. For example, a condition of –40 V on one input and +40 V on the other input does not cause damage. Internal circuitry on each input provides low series impedance under normal signal conditions. To provide equivalent protection, series input resistors contributes excessive noise. If the input is overloaded, the protection circuitry limits the input current to a safe value of approximately 1.50 mA to 5 mA. The inputs are protected even if the power supplies are disconnected or turned off.

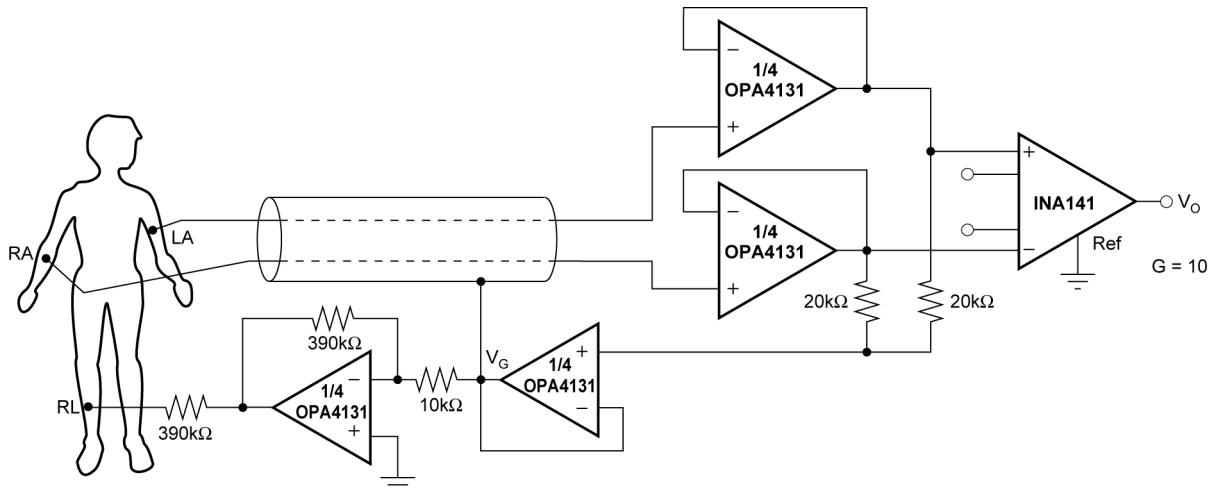

Figure 7-4. ECG Amplifier With Right-Leg Drive

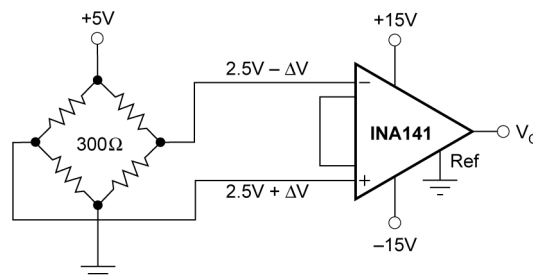

Figure 7-5. Bridge Amplifier

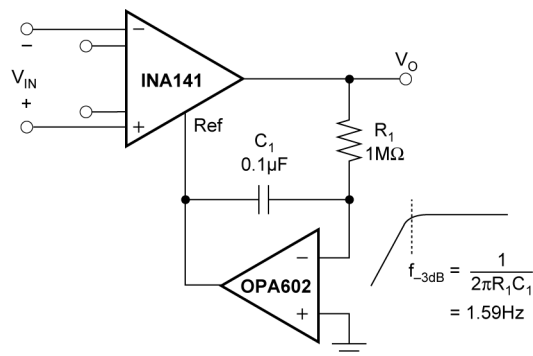
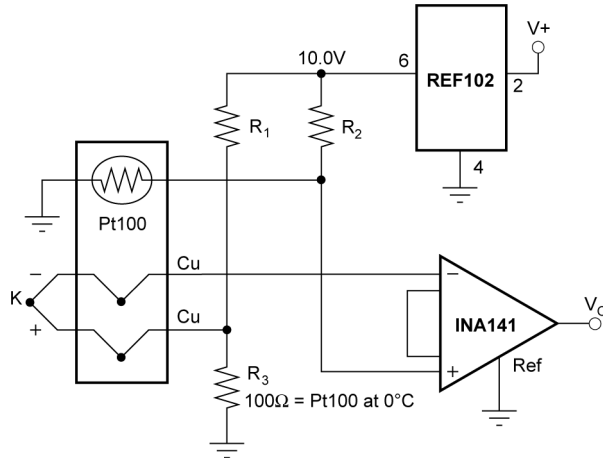

Figure 7-6. AC-Coupled Instrumentation Amplifier



ISA TYPE	MATERIAL	SEEBECK COEFFICIENT ($\mu\text{V}/^\circ\text{C}$)	R_1, R_2
E	+ Chromel - Constantan	58.5	66.5k Ω
J	+ Iron - Constantan	50.2	76.8k Ω
K	+ Chromel - Alumel	39.4	97.6k Ω
T	+ Copper - Constantan	38.0	102k Ω

Figure 7-7. Thermocouple Amplifier With RTD Cold-Junction Compensation

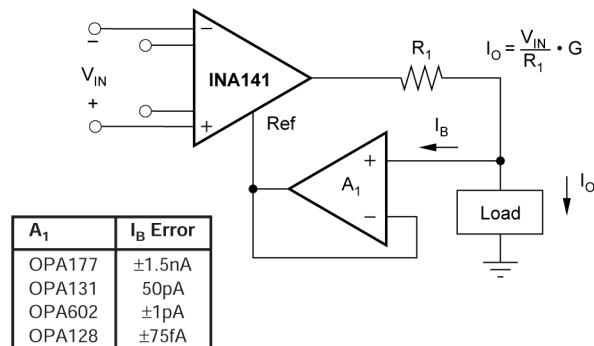

Figure 7-8. Differential Voltage-to-Current Converter

8 Device and Documentation Support

TI offers an extensive line of development tools. Tools and software to evaluate the performance of the device, generate code, and develop solutions are listed below.

8.1 Receiving Notification of Documentation Updates

To receive notification of documentation updates, navigate to the device product folder on ti.com. Click on *Subscribe to updates* to register and receive a weekly digest of any product information that has changed. For change details, review the revision history included in any revised document.

8.2 Support Resources

TI E2E™ [support forums](#) are an engineer's go-to source for fast, verified answers and design help — straight from the experts. Search existing answers or ask your own question to get the quick design help you need.

Linked content is provided "AS IS" by the respective contributors. They do not constitute TI specifications and do not necessarily reflect TI's views; see TI's [Terms of Use](#).

8.3 Trademarks

TI E2E™ is a trademark of Texas Instruments.

All trademarks are the property of their respective owners.

8.4 Electrostatic Discharge Caution



This integrated circuit can be damaged by ESD. Texas Instruments recommends that all integrated circuits be handled with appropriate precautions. Failure to observe proper handling and installation procedures can cause damage.

ESD damage can range from subtle performance degradation to complete device failure. Precision integrated circuits may be more susceptible to damage because very small parametric changes could cause the device not to meet its published specifications.

8.5 Glossary

[TI Glossary](#) This glossary lists and explains terms, acronyms, and definitions.

9 Mechanical, Packaging, and Orderable Information

The following pages include mechanical, packaging, and orderable information. This information is the most current data available for the designated devices. This data is subject to change without notice and revision of this document. For browser-based versions of this data sheet, refer to the left-hand navigation.

PACKAGING INFORMATION

Orderable Device	Status (1)	Package Type	Package Drawing	Pins	Package Qty	Eco Plan (2)	Lead finish/ Ball material (6)	MSL Peak Temp (3)	Op Temp (°C)	Device Marking (4/5)	Samples
INA141U	ACTIVE	SOIC	D	8	75	RoHS & Green	Call TI NIPDAU	Level-3-260C-168 HR		INA 141U	Samples
INA141U/2K5	ACTIVE	SOIC	D	8	2500	RoHS & Green	Call TI NIPDAU	Level-3-260C-168 HR		INA 141U	Samples
INA141UA	ACTIVE	SOIC	D	8	75	RoHS & Green	Call TI NIPDAU	Level-3-260C-168 HR	-40 to 85	INA 141U A	Samples
INA141UA/2K5	ACTIVE	SOIC	D	8	2500	RoHS & Green	Call TI NIPDAU	Level-3-260C-168 HR	-40 to 85	INA 141U A	Samples
INA141UA/2K5E4	LIFEBUY	SOIC	D	8	2500	RoHS & Green	Call TI	Level-3-260C-168 HR	-40 to 85	INA 141U A	
INA141UAE4	LIFEBUY	SOIC	D	8	75	RoHS & Green	Call TI	Level-3-260C-168 HR	-40 to 85	INA 141U A	

(1) The marketing status values are defined as follows:

ACTIVE: Product device recommended for new designs.

LIFEBUY: TI has announced that the device will be discontinued, and a lifetime-buy period is in effect.

NRND: Not recommended for new designs. Device is in production to support existing customers, but TI does not recommend using this part in a new design.

PREVIEW: Device has been announced but is not in production. Samples may or may not be available.

OBSOLETE: TI has discontinued the production of the device.

(2) **RoHS:** TI defines "RoHS" to mean semiconductor products that are compliant with the current EU RoHS requirements for all 10 RoHS substances, including the requirement that RoHS substance do not exceed 0.1% by weight in homogeneous materials. Where designed to be soldered at high temperatures, "RoHS" products are suitable for use in specified lead-free processes. TI may reference these types of products as "Pb-Free".

RoHS Exempt: TI defines "RoHS Exempt" to mean products that contain lead but are compliant with EU RoHS pursuant to a specific EU RoHS exemption.

Green: TI defines "Green" to mean the content of Chlorine (Cl) and Bromine (Br) based flame retardants meet JS709B low halogen requirements of <=1000ppm threshold. Antimony trioxide based flame retardants must also meet the <=1000ppm threshold requirement.

(3) MSL, Peak Temp. - The Moisture Sensitivity Level rating according to the JEDEC industry standard classifications, and peak solder temperature.

(4) There may be additional marking, which relates to the logo, the lot trace code information, or the environmental category on the device.

⁽⁵⁾ Multiple Device Markings will be inside parentheses. Only one Device Marking contained in parentheses and separated by a "~" will appear on a device. If a line is indented then it is a continuation of the previous line and the two combined represent the entire Device Marking for that device.

⁽⁶⁾ Lead finish/Ball material - Orderable Devices may have multiple material finish options. Finish options are separated by a vertical ruled line. Lead finish/Ball material values may wrap to two lines if the finish value exceeds the maximum column width.

Important Information and Disclaimer:The information provided on this page represents TI's knowledge and belief as of the date that it is provided. TI bases its knowledge and belief on information provided by third parties, and makes no representation or warranty as to the accuracy of such information. Efforts are underway to better integrate information from third parties. TI has taken and continues to take reasonable steps to provide representative and accurate information but may not have conducted destructive testing or chemical analysis on incoming materials and chemicals. TI and TI suppliers consider certain information to be proprietary, and thus CAS numbers and other limited information may not be available for release.

In no event shall TI's liability arising out of such information exceed the total purchase price of the TI part(s) at issue in this document sold by TI to Customer on an annual basis.

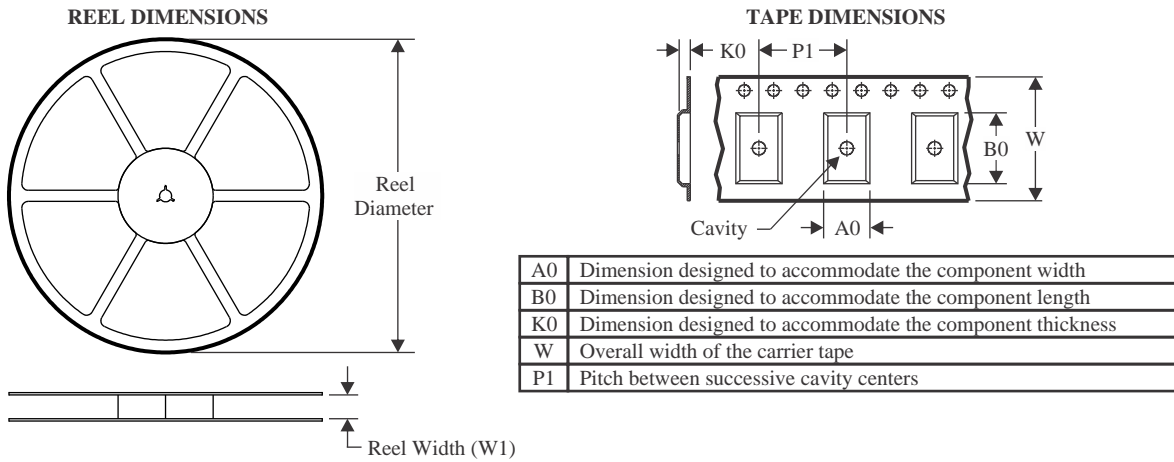
TAPE AND REEL INFORMATION

QUADRANT ASSIGNMENTS FOR PIN 1 ORIENTATION IN TAPE

*All dimensions are nominal

Device	Package Type	Package Drawing	Pins	SPQ	Reel Diameter (mm)	Reel Width W1 (mm)	A0 (mm)	B0 (mm)	K0 (mm)	P1 (mm)	W (mm)	Pin1 Quadrant
INA141U/2K5	SOIC	D	8	2500	330.0	12.4	6.4	5.2	2.1	8.0	12.0	Q1
INA141U/2K5	SOIC	D	8	2500	330.0	12.4	6.4	5.2	2.1	8.0	12.0	Q1
INA141UA/2K5	SOIC	D	8	2500	330.0	12.4	6.4	5.2	2.1	8.0	12.0	Q1

TAPE AND REEL BOX DIMENSIONS

*All dimensions are nominal

Device	Package Type	Package Drawing	Pins	SPQ	Length (mm)	Width (mm)	Height (mm)
INA141U/2K5	SOIC	D	8	2500	367.0	367.0	35.0
INA141U/2K5	SOIC	D	8	2500	353.0	353.0	32.0
INA141UA/2K5	SOIC	D	8	2500	356.0	356.0	35.0

TUBE

*All dimensions are nominal

Device	Package Name	Package Type	Pins	SPQ	L (mm)	W (mm)	T (μm)	B (mm)
INA141U	D	SOIC	8	75	506.6	8	3940	4.32
INA141UA	D	SOIC	8	75	506.6	8	3940	4.32
INA141UAE4	D	SOIC	8	75	506.6	8	3940	4.32



D0008A

PACKAGE OUTLINE

SOIC - 1.75 mm max height

SMALL OUTLINE INTEGRATED CIRCUIT



4214825/C 02/2019

NOTES:

- Linear dimensions are in inches [millimeters]. Dimensions in parenthesis are for reference only. Controlling dimensions are in inches. Dimensioning and tolerancing per ASME Y14.5M.
- This drawing is subject to change without notice.
- This dimension does not include mold flash, protrusions, or gate burrs. Mold flash, protrusions, or gate burrs shall not exceed $.006$ [0.15] per side.
- This dimension does not include interlead flash.
- Reference JEDEC registration MS-012, variation AA.

EXAMPLE BOARD LAYOUT

D0008A

SOIC - 1.75 mm max height

SMALL OUTLINE INTEGRATED CIRCUIT



LAND PATTERN EXAMPLE
EXPOSED METAL SHOWN
SCALE:8X



SOLDER MASK DETAILS

4214825/C 02/2019

NOTES: (continued)

6. Publication IPC-7351 may have alternate designs.

7. Solder mask tolerances between and around signal pads can vary based on board fabrication site.

EXAMPLE STENCIL DESIGN

D0008A

SOIC - 1.75 mm max height

SMALL OUTLINE INTEGRATED CIRCUIT



SOLDER PASTE EXAMPLE
BASED ON .005 INCH [0.125 MM] THICK STENCIL
SCALE:8X

4214825/C 02/2019

NOTES: (continued)

8. Laser cutting apertures with trapezoidal walls and rounded corners may offer better paste release. IPC-7525 may have alternate design recommendations.
9. Board assembly site may have different recommendations for stencil design.

IMPORTANT NOTICE AND DISCLAIMER

TI PROVIDES TECHNICAL AND RELIABILITY DATA (INCLUDING DATA SHEETS), DESIGN RESOURCES (INCLUDING REFERENCE DESIGNS), APPLICATION OR OTHER DESIGN ADVICE, WEB TOOLS, SAFETY INFORMATION, AND OTHER RESOURCES "AS IS" AND WITH ALL FAULTS, AND DISCLAIMS ALL WARRANTIES, EXPRESS AND IMPLIED, INCLUDING WITHOUT LIMITATION ANY IMPLIED WARRANTIES OF MERCHANTABILITY, FITNESS FOR A PARTICULAR PURPOSE OR NON-INFRINGEMENT OF THIRD PARTY INTELLECTUAL PROPERTY RIGHTS.

These resources are intended for skilled developers designing with TI products. You are solely responsible for (1) selecting the appropriate TI products for your application, (2) designing, validating and testing your application, and (3) ensuring your application meets applicable standards, and any other safety, security, regulatory or other requirements.

These resources are subject to change without notice. TI grants you permission to use these resources only for development of an application that uses the TI products described in the resource. Other reproduction and display of these resources is prohibited. No license is granted to any other TI intellectual property right or to any third party intellectual property right. TI disclaims responsibility for, and you will fully indemnify TI and its representatives against, any claims, damages, costs, losses, and liabilities arising out of your use of these resources.

TI's products are provided subject to [TI's Terms of Sale](#) or other applicable terms available either on [ti.com](https://www.ti.com) or provided in conjunction with such TI products. TI's provision of these resources does not expand or otherwise alter TI's applicable warranties or warranty disclaimers for TI products.

TI objects to and rejects any additional or different terms you may have proposed.

Mailing Address: Texas Instruments, Post Office Box 655303, Dallas, Texas 75265
Copyright © 2024, Texas Instruments Incorporated

Looking for pricing, stock, or lifecycle information?

Click below to explore more details on WIN SOURCE:

 [View INA141UA](#) on WIN SOURCE

 [Texas Instruments](#) Information

Optimize Your Supply Chain with WIN SOURCE Solutions

-  Global Sourcing Solution
-  Obsolete Management
-  Cost Control Management
-  Shortage Management
-  Alternative Solution
-  Excess Inventory Management