



**THE DATASHEET OF  
AD8417WHRMZ-RL**



### FEATURES

- Typical 0.1  $\mu\text{V}/^\circ\text{C}$  offset drift
- Maximum  $\pm 400 \mu\text{V}$  voltage offset over full temperature range
- 2.7 V to 5.5 V power supply operating range
- EMI filters included
- High common-mode input voltage range
  - 2 V to +70 V continuous
  - 3 V to +80 V survival
- Initial gain = 60 V/V
- Wide operating temperature range
  - AD8417WB (8-lead MSOP, 8-lead SOIC\_N, and 10-lead MSOP) and AD8417B (8-lead MSOP):  $-40^\circ\text{C}$  to  $+125^\circ\text{C}$
  - AD8417WH (8-lead SOIC\_N and 8-lead MSOP):  $-40^\circ\text{C}$  to  $+150^\circ\text{C}$
- Bidirectional operation
- Available in 8-lead SOIC\_N, 8-lead MSOP, and FMEA tolerant 10-lead MSOP pinout
- CMRR: 86 dB, dc to 10 kHz
- AEC-Q100 qualified for automotive applications

### APPLICATIONS

- High-side current sensing in
  - Motor controls
  - Solenoid controls
  - Power management
- Low-side current sensing
- Diagnostic protection

### GENERAL DESCRIPTION

The AD8417 is a high voltage, high resolution current sense amplifier. It features an initial gain of 60 V/V, with a maximum  $\pm 0.3\%$  gain error over the entire temperature range. The buffered output voltage directly interfaces with any typical converter. The AD8417 offers excellent input common-mode rejection from  $-2 \text{ V}$  to  $+70 \text{ V}$ . The AD8417 performs bidirectional current measurements across a shunt resistor in a variety of automotive and industrial applications, including motor control, power management, and solenoid control.

The AD8417 offers breakthrough performance throughout the  $-40^\circ\text{C}$  to  $+150^\circ\text{C}$  temperature range (AD8417WH). It features a zero drift core, which leads to a typical offset drift of  $0.1 \mu\text{V}/^\circ\text{C}$  throughout the operating temperature range and the common-mode voltage range. The AD8417 is qualified for automotive applications. The device includes electromagnetic interference (EMI) filters and patented (U.S. Patent 8,624,668 B2) circuitry to enable output accuracy with pulse-width modulation (PWM) type input common-mode voltages. The typical input offset voltage is  $\pm 200 \mu\text{V}$ . The AD8417 is offered in 8-lead MSOP and 8-lead SOIC\_N, along with a 10-lead MSOP pinout option engineered for failure mode and effects analysis (FMEA).

Table 1. Related Devices

| Part No. | Description                                      |
|----------|--|
| AD8205   | Current sense amplifier, gain = 50               |
| AD8206   | Current sense amplifier, gain = 20               |
| AD8207   | High accuracy current sense amplifier, gain = 20 |
| AD8210   | High speed current sense amplifier, gain = 20    |
| AD8418   | High accuracy current sense amplifier, gain = 20 |

### TYPICAL APPLICATION CIRCUIT

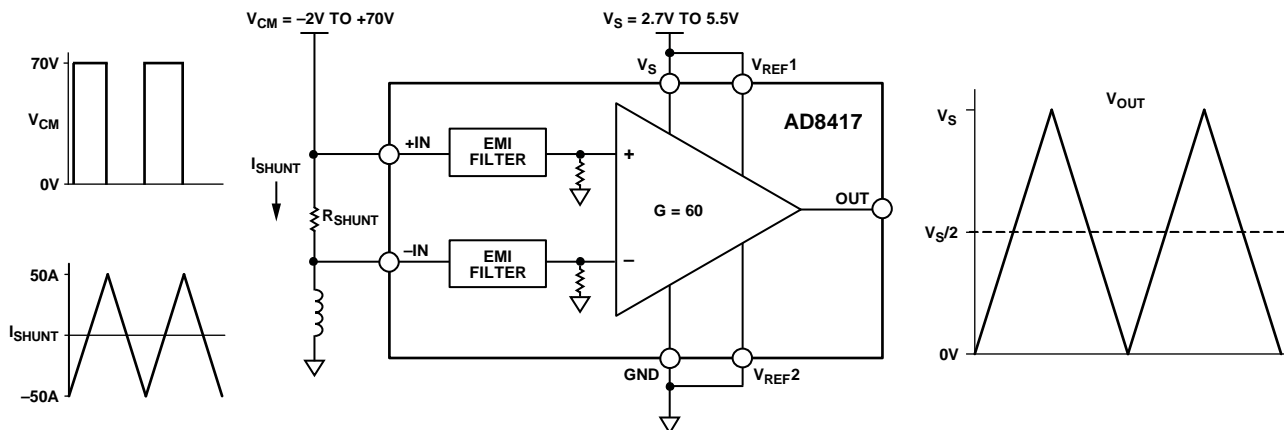

Figure 1.

Rev. E

[Document Feedback](#)

Information furnished by Analog Devices is believed to be accurate and reliable. However, no responsibility is assumed by Analog Devices for its use, nor for any infringements of patents or other rights of third parties that may result from its use. Specifications subject to change without notice. No license is granted by implication or otherwise under any patent or patent rights of Analog Devices. Trademarks and registered trademarks are the property of their respective owners.

11802-001

## TABLE OF CONTENTS

|   |    |  |    |
|---|----|--|----|
| Features.....                                     | 1  | Bidirectional Operation .....          | 11 |
| Applications .....                                | 1  | External Referenced Output .....       | 12 |
| General Description .....                         | 1  | Splitting the Supply.....              | 12 |
| Typical Application Circuit .....                 | 1  | Splitting an External Reference.....   | 12 |
| Revision History .....                            | 2  | Applications Information .....         | 13 |
| Specifications.....                               | 3  | Motor Control .....                    | 13 |
| Absolute Maximum Ratings .....                    | 4  | Solenoid Control .....                 | 14 |
| ESD Caution.....                                  | 4  | Pinout Option Engineered for FMEA..... | 15 |
| Pin Configurations and Function Descriptions..... | 5  | Outline Dimensions.....                | 16 |
| Typical Performance Characteristics.....          | 6  | Ordering Guide .....                   | 17 |
| Theory of Operation .....                         | 10 | Automotive Products .....              | 17 |
| Output Offset Adjustment .....                    | 11 |  |    |
| Unidirectional Operation.....                     | 11 |  |    |

## REVISION HISTORY

### 3/2020—Rev. D to Rev. E

|   |            |
|---|------------|
| Added 10-Lead MSOP.....   | Universal  |
| Changed AD8417WB to AD8417WB and AD8417B, and Patented to Patented (U.S. Patent 8,624,668 B2) ..... | Throughout |
| Changes to Features Section and General Description Section .....                                   | 1          |
| Changed Functional Block Diagram Section to Typical Application Circuit Section.....                | 1          |
| Changes to Figure 2 and Table 4 Caption.....  | 5          |
| Added Figure 3; Renumbered Sequentially and Table 5; Renumbered Sequentially .....                  | 5          |
| Changes to Figure 11 to Figure 15 .....   | 7          |
| Changes to Figure 16 to Figure 19 .....   | 8          |
| Change to Figure 23 .....   | 9          |
| Deleted Figure 26; Renumbered Sequentially .....  | 10         |
| Added Pinout Option Engineered for FMEA Section and Table 6.....                                    | 15         |
| Updated Outline Dimensions.....   | 17         |
| Changes to Ordering Guide.....  | 17         |

### 6/2019—Rev. C to Rev. D

|                                   |    |
|-----------------------------------|----|
| Changes to Features Section ..... | 1  |
| Changes to Table 3.....           | 4  |
| Changes to Figure 33 .....        | 13 |

### 10/2017—Rev. B to Rev. C

|   |    |
|---|----|
| Change to Splitting an External Reference Section ..... | 12 |
|---|----|

### 4/2015—Rev. A to Rev. B

|                          |    |
|--------------------------|----|
| Change to Figure 36..... | 14 |
|--------------------------|----|

### 11/2014—Rev. 0 to Rev. A

|   |           |
|---|-----------|
| Added AD8417WH .....  | Universal |
| Changes to Features Section and General Description Section ..... | 1         |
| Changes to Specifications Section and Table 2.....                | 3         |
| Changes to Table 3.....   | 4         |
| Changes to Ordering Guide.....                                    | 16        |

### 11/2013—Revision 0: Initial Version

## SPECIFICATIONS

$T_A = -40^\circ\text{C}$  to  $+125^\circ\text{C}$  (operating temperature range) for the AD8417WB and AD8417B,  $T_A = -40^\circ\text{C}$  to  $+150^\circ\text{C}$  for the AD8417WH,  $V_S = 5\text{ V}$ , unless otherwise noted.

Table 2.

| Parameter                                   | Test Conditions/Comments  | Min   | Typ       | Max           | Unit                         |
|---|---|-------|-----------|---------------|------------------------------|
| GAIN  |   |       |           |               |                              |
| Initial                                     |   |       | 60        |               | V/V                          |
| Error Over Temperature                      | Specified temperature range   |       |           | $\pm 0.3$     | %                            |
| Gain vs. Temperature                        |   | -10   |           | +10           | ppm/ $^\circ\text{C}$        |
| VOLTAGE OFFSET                              |   |       |           |               |                              |
| Offset Voltage, Referred to the Input (RTI) | 25 $^\circ\text{C}$   |       | $\pm 200$ |               | $\mu\text{V}$                |
| Over Temperature, RTI                       | Specified temperature range   |       |           | $\pm 400$     | $\mu\text{V}$                |
| Offset Drift                                |   | -0.4  | +0.1      | +0.4          | $\mu\text{V}/^\circ\text{C}$ |
| INPUT                                       |   |       |           |               |                              |
| Input Bias Current                          |   |       | 130       |               | $\mu\text{A}$                |
| Input Voltage Range                         | Common mode, continuous   | -2    |           | +70           | V                            |
| Common-Mode Rejection Ratio (CMRR)          | Specified temperature range, $f = \text{dc}$<br>$f = \text{dc}$ to 10 kHz | 90    | 100       |               | dB                           |
|   |   |       | 86        |               | dB                           |
| OUTPUT                                      |   |       |           |               |                              |
| Output Voltage Range                        | $R_L = 25\text{ k}\Omega$   | 0.045 |           | $V_S - 0.035$ | V                            |
| Output Resistance                           |   |       | 2         |               | $\Omega$                     |
| DYNAMIC RESPONSE                            |   |       |           |               |                              |
| Small Signal -3 dB Bandwidth                |   |       | 250       |               | kHz                          |
| Slew Rate                                   |   |       | 1         |               | V/ $\mu\text{s}$             |
| NOISE                                       |   |       |           |               |                              |
| 0.1 Hz to 10 Hz, RTI                        |   |       | 2.3       |               | $\mu\text{V p-p}$            |
| Spectral Density, 1 kHz, RTI                |   |       | 110       |               | nV/ $\sqrt{\text{Hz}}$       |
| OFFSET ADJUSTMENT                           |   |       |           |               |                              |
| Ratiometric Accuracy <sup>1</sup>           | Divider to supplies   | 0.499 |           | 0.501         | V/V                          |
| Accuracy, Referred to the Output (RTO)      | Voltage applied to $V_{\text{REF}1}$ and $V_{\text{REF}2}$ in parallel    |       |           | $\pm 1$       | mV/V                         |
| Output Offset Adjustment Range              | $V_S = 5\text{ V}$  | 0.045 |           | $V_S - 0.035$ | V                            |
| POWER SUPPLY                                |   |       |           |               |                              |
| Operating Range                             |   | 2.7   |           | 5.5           | V                            |
| Quiescent Current Over Temperature          | $V_{\text{OUT}} = 0.1\text{ V dc}$<br>AD8417WB and AD8417B<br>AD8417WH    |       |           | 4.1           | mA                           |
|   |   |       |           | 4.2           | mA                           |
| Power Supply Rejection Ratio                |   | 80    |           |               | dB                           |
| Temperature Range                           |   |       |           |               |                              |
| For Specified Performance                   |   |       |           |               |                              |
| Operating Temperature Range                 | AD8417WB and AD8417B<br>AD8417WH  | -40   |           | +125          | $^\circ\text{C}$             |
|   |   | -40   |           | +150          | $^\circ\text{C}$             |

<sup>1</sup> The offset adjustment is ratiometric to the power supply when  $V_{\text{REF}1}$  and  $V_{\text{REF}2}$  are used as a divider between the supplies.

## ABSOLUTE MAXIMUM RATINGS

Table 3.

| Parameter                     | Rating            |
|-------------------------------|-------------------|
| Supply Voltage                | 6 V               |
| Input Voltage Range           |                   |
| Survival Common-Mode          | –3 V to +80 V     |
| Differential                  | 5.5 V (magnitude) |
| Reverse Supply Voltage        | 0.3 V             |
| ESD Human Body Model (HBM)    | ±2000 V           |
| Operating Temperature Range   |                   |
| AD8417WB and AD8417B          | –40°C to +125°C   |
| AD8417WH                      | –40°C to +150°C   |
| Storage Temperature Range     | –65°C to +150°C   |
| Output Short-Circuit Duration | Indefinite        |

Stresses at or above those listed under Absolute Maximum Ratings may cause permanent damage to the product. This is a stress rating only; functional operation of the product at these or any other conditions above those indicated in the operational section of this specification is not implied. Operation beyond the maximum operating conditions for extended periods may affect product reliability.

### ESD CAUTION



**ESD (electrostatic discharge) sensitive device.** Charged devices and circuit boards can discharge without detection. Although this product features patented or proprietary protection circuitry, damage may occur on devices subjected to high energy ESD. Therefore, proper ESD precautions should be taken to avoid performance degradation or loss of functionality.

## PIN CONFIGURATIONS AND FUNCTION DESCRIPTIONS

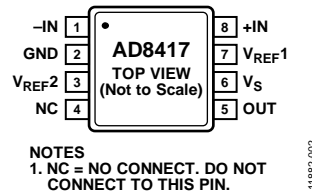

Figure 2. 8-Lead MSOP and 8-Lead SOIC\_N Pin Configuration

Table 4. 8-Lead MSOP and 8-Lead SOIC\_N Pin Function Descriptions

| Pin No. | Mnemonic          | Description                             |
|---------|-------------------|---|
| 1       | -IN               | Negative Input.                         |
| 2       | GND               | Ground.                                 |
| 3       | V <sub>REF2</sub> | Reference Input 2.                      |
| 4       | NC                | No Connect. Do not connect to this pin. |
| 5       | OUT               | Output.                                 |
| 6       | V <sub>S</sub>    | Supply.                                 |
| 7       | V <sub>REF1</sub> | Reference Input 1.                      |
| 8       | +IN               | Positive Input.                         |

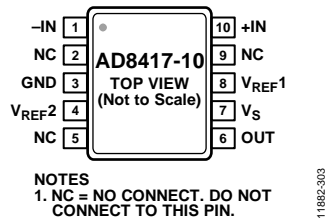

Figure 3. 10-Lead MSOP Pin Configuration

Table 5. 10-Lead MSOP Pin Function Descriptions

| Pin No. | Mnemonic          | Description                             |
|---------|-------------------|---|
| 1       | -IN               | Negative Input.                         |
| 2       | NC                | No Connect. Do not connect to this pin. |
| 3       | GND               | Ground.                                 |
| 4       | V <sub>REF2</sub> | Reference Input 2.                      |
| 5       | NC                | No Connect. Do not connect to this pin. |
| 6       | OUT               | Output.                                 |
| 7       | V <sub>S</sub>    | Supply.                                 |
| 8       | V <sub>REF1</sub> | Reference Input 1.                      |
| 9       | NC                | No Connect. Do not connect to this pin. |
| 10      | +IN               | Positive Input.                         |

### TYPICAL PERFORMANCE CHARACTERISTICS

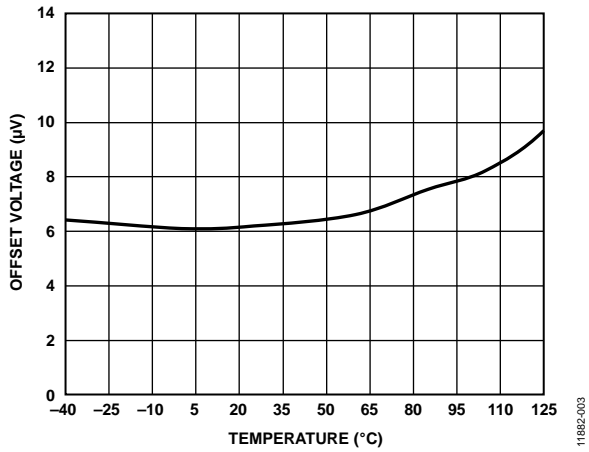

Figure 4. Typical Offset Voltage Drift vs. Temperature

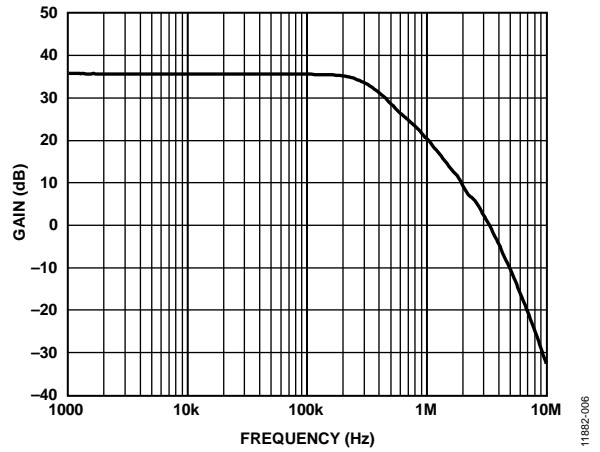

Figure 7. Typical Small Signal Bandwidth ( $V_{OUT} = 200\text{ mV p-p}$ )

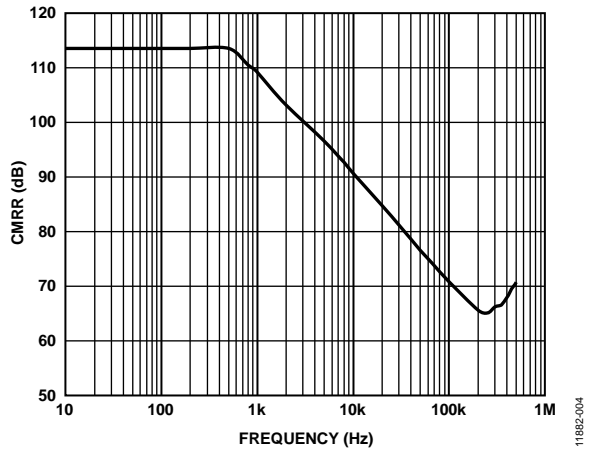

Figure 5. Typical CMRR vs. Frequency

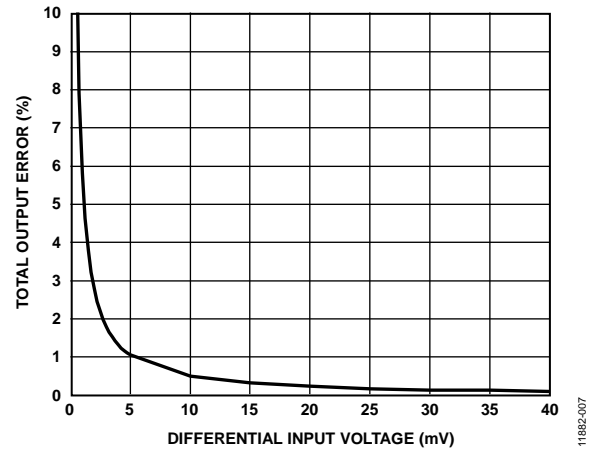

Figure 8. Total Output Error vs. Differential Input Voltage

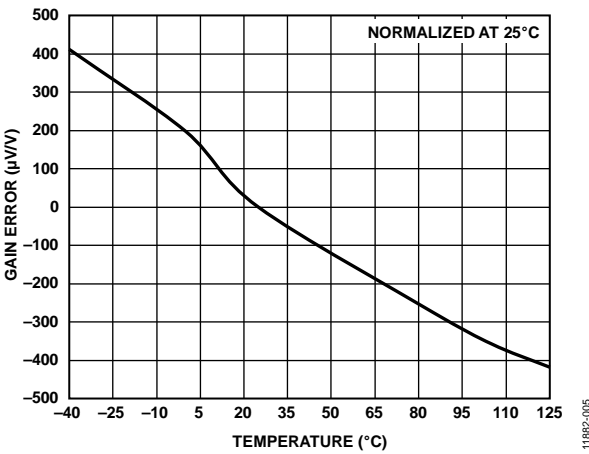

Figure 6. Typical Gain Error vs. Temperature

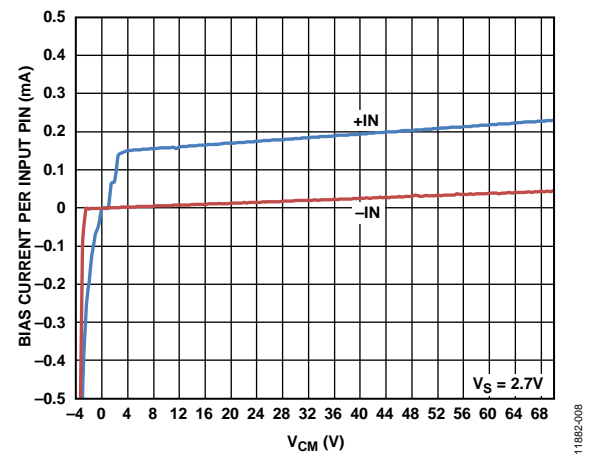

Figure 9. Bias Current per Input Pin vs.  $V_{CM}$

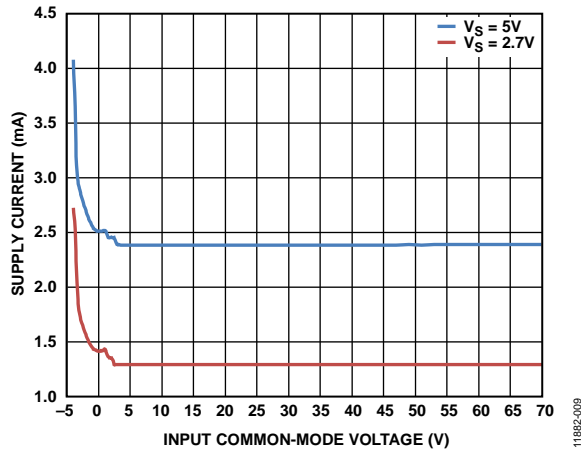

Figure 10. Supply Current vs. Input Common-Mode Voltage

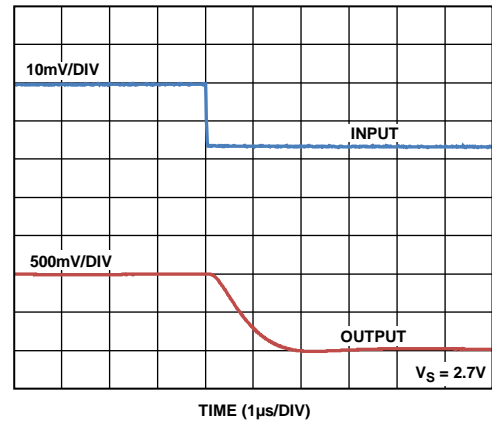

Figure 13. Fall Time ( $V_S = 2.7V$ )

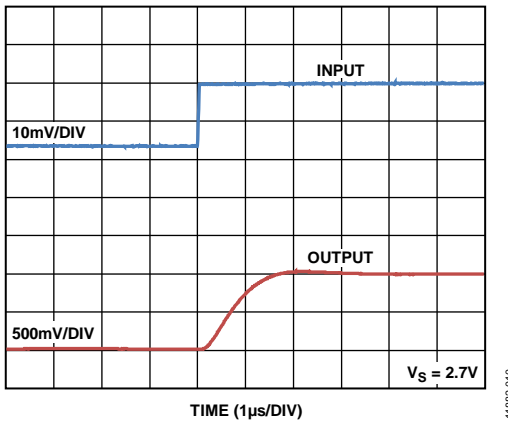

Figure 11. Rise Time ( $V_S = 2.7V$ )

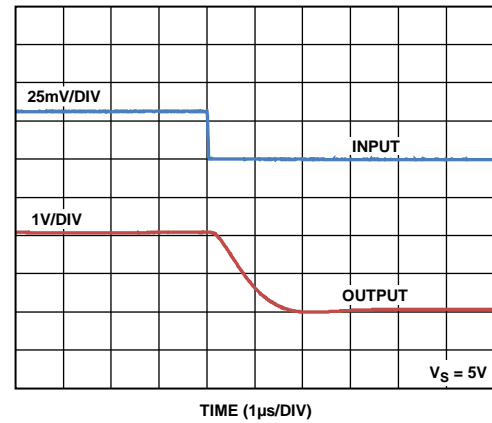

Figure 14. Fall Time ( $V_S = 5V$ )

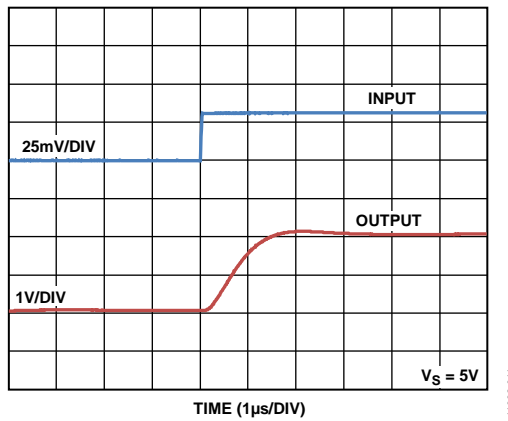

Figure 12. Rise Time ( $V_S = 5V$ )

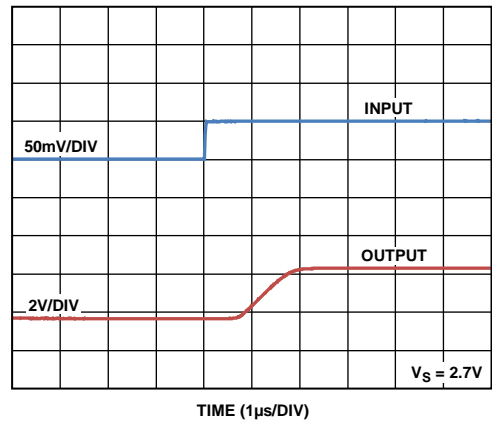

Figure 15. Differential Overload Recovery, Rising ( $V_S = 2.7V$ )

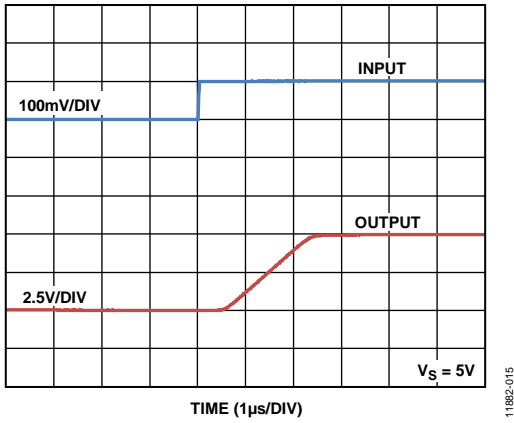

Figure 16. Differential Overload Recovery, Rising ( $V_S = 5\text{ V}$ )

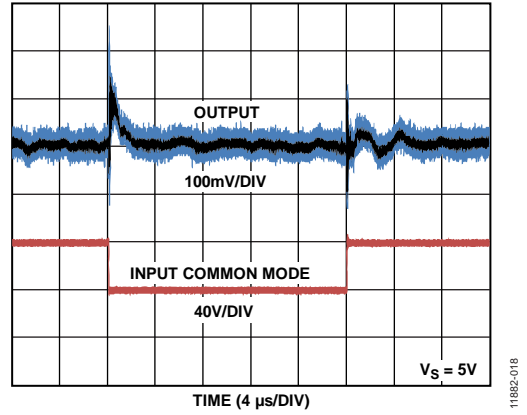

Figure 19. Input Common-Mode Step Response ( $V_S = 5\text{ V}$ , Inputs Shorted)

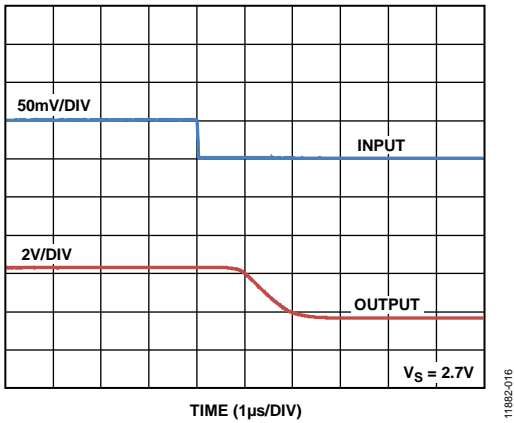

Figure 17. Differential Overload Recovery, Falling ( $V_S = 2.7\text{ V}$ )

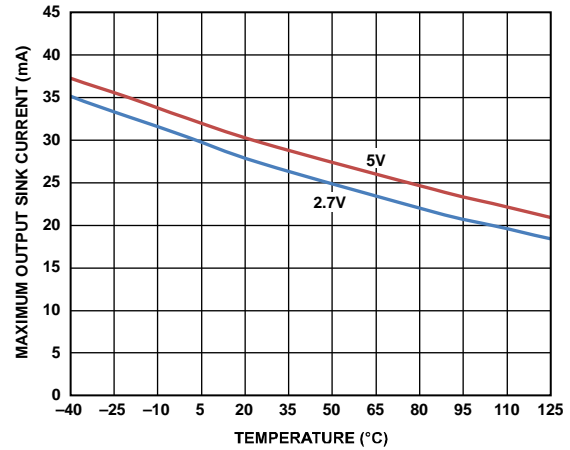

Figure 20. Maximum Output Sink Current vs. Temperature

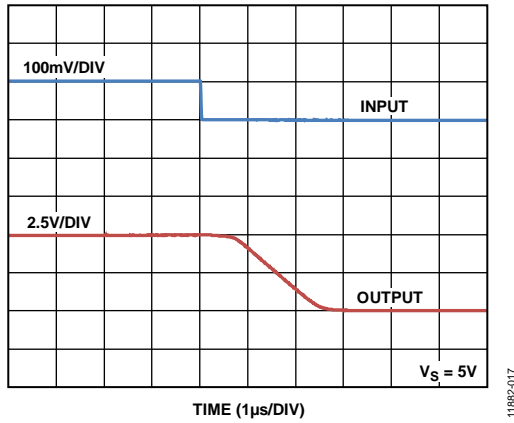

Figure 18. Differential Overload Recovery, Falling ( $V_S = 5\text{ V}$ )

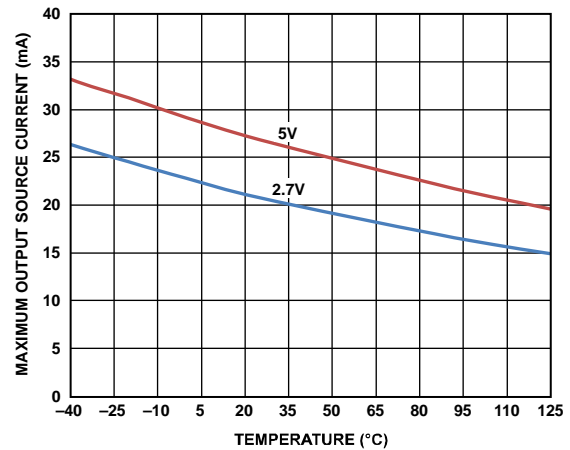

Figure 21. Maximum Output Source Current vs. Temperature

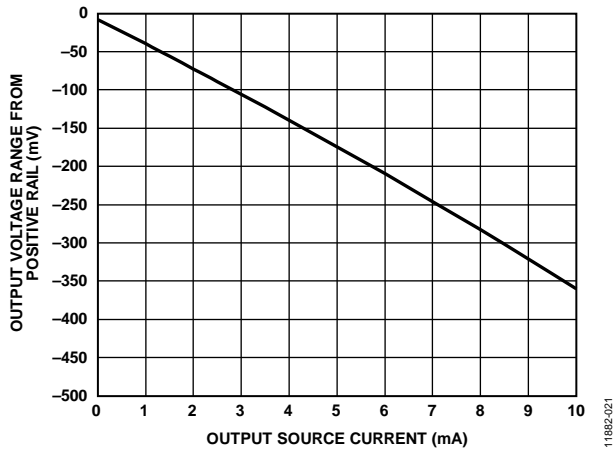

Figure 22. Output Voltage Range from Positive Rail vs. Output Source Current

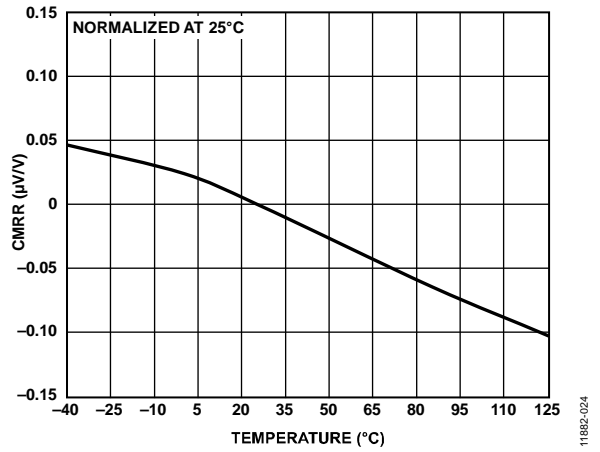

Figure 25. CMRR vs. Temperature

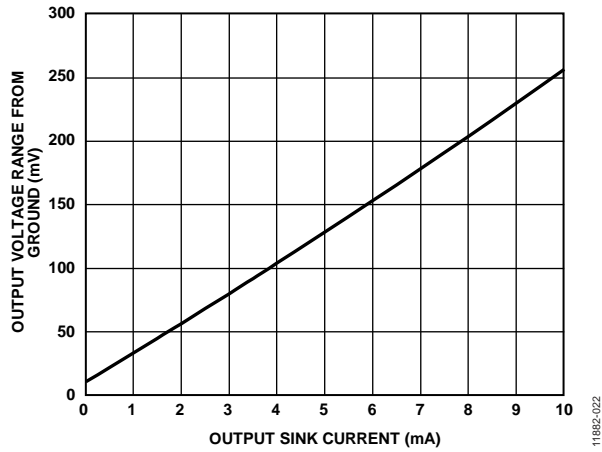

Figure 23. Output Voltage Range from Ground vs. Output Sink Current

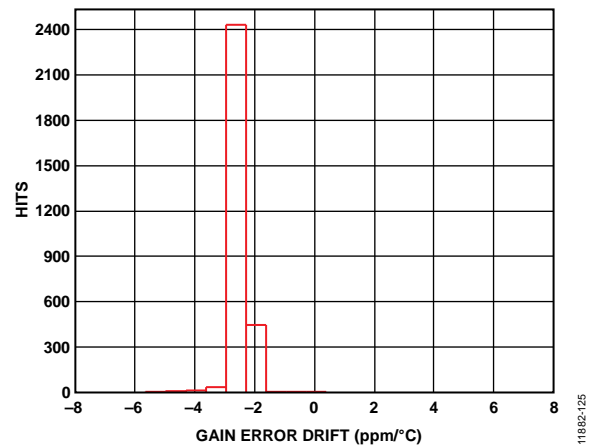

Figure 26. Gain Error Drift Distribution

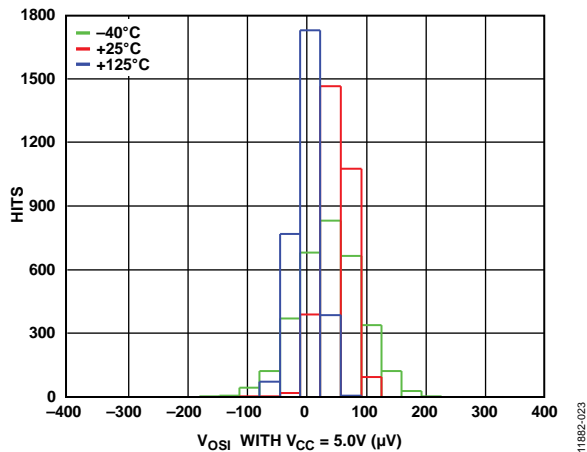

Figure 24. Offset Voltage Distribution

## THEORY OF OPERATION

The AD8417 is a single-supply, zero drift, difference amplifier that uses a unique architecture to accurately amplify small differential current shunt voltages in the presence of rapidly changing common-mode voltages.

In typical applications, the AD8417 measures current by amplifying the voltage across a shunt resistor connected to its inputs by a gain of 60 V/V (see Figure 1).

The AD8417 design provides excellent common-mode rejection, even with PWM common-mode inputs that can change at very fast rates, for example, 1 V/ns. The AD8417 contains patented (U.S. Patent 8,624,668 B2) technology to eliminate the negative effects of such fast changing external common-mode variations.

The AD8417 features an input offset drift of less than 0.4  $\mu\text{V}/^\circ\text{C}$ . This performance is achieved through a novel zero

drift architecture that does not compromise bandwidth, which is typically rated at 250 kHz.

The reference inputs,  $V_{\text{REF1}}$  and  $V_{\text{REF2}}$ , are tied through 100 k $\Omega$  resistors to the positive input of the main amplifier, which allows the output offset to be adjusted anywhere in the output operating range. The gain is 1 V/V from the reference pins to the output when the reference pins are used in parallel. When the pins are used to divide the supply, the gain is 0.5 V/V.

The AD8417 offers breakthrough performance without compromising any of the robust application needs typical of solenoid or motor control. The ability to reject PWM input common-mode voltages and the zero drift architecture providing low offset and offset drift allows the AD8417 to deliver total accuracy for these demanding applications.

## OUTPUT OFFSET ADJUSTMENT

The output of the AD8417 can be adjusted for unidirectional or bidirectional operation.

### UNIDIRECTIONAL OPERATION

Unidirectional operation allows the AD8417 to measure currents through a resistive shunt in one direction. The basic modes for unidirectional operation are ground referenced output mode and  $V_S$  referenced output mode.

For unidirectional operation, the output can be set at the negative rail (near ground) or at the positive rail (near  $V_S$ ) when the differential input is 0 V. The output moves to the opposite rail when a correct polarity differential input voltage is applied. The required polarity of the differential input depends on the output voltage setting. If the output is set at the positive rail, the input polarity must be negative to decrease the output. If the output is set at ground, the polarity must be positive to increase the output.

#### Ground Referenced Output Mode

When using the AD8417 in ground referenced output mode, both referenced inputs are tied to ground, which causes the output to sit at the negative rail when there are zero differential volts at the input (see Figure 27).

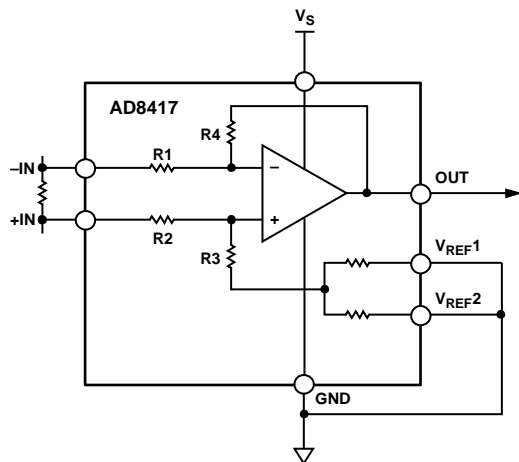

Figure 27. Ground Referenced Output

#### $V_S$ Referenced Output Mode

$V_S$  referenced output mode is set when both reference pins are tied to the positive supply. It is typically used when the diagnostic scheme requires detection of the amplifier and the wiring before power is applied to the load (see Figure 28).

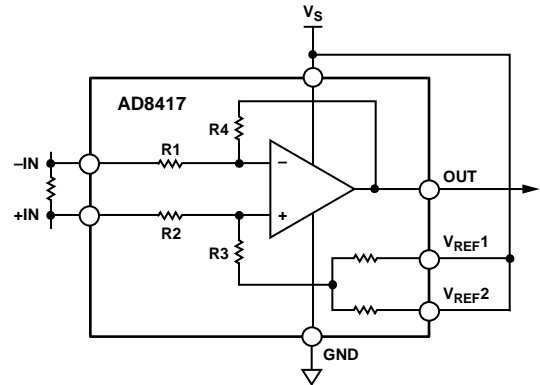

Figure 28.  $V_S$  Referenced Output

### BIDIRECTIONAL OPERATION

Bidirectional operation allows the AD8417 to measure currents through a resistive shunt in two directions.

In this case, the output is set anywhere within the output range. Typically, it is set at half scale for equal range in both directions. In some cases, however, it is set at a voltage other than half scale when the bidirectional current is nonsymmetrical.

Apply voltage(s) to the referenced inputs to adjust the output.  $V_{REF1}$  and  $V_{REF2}$  are tied to internal resistors that connect to an internal offset node. There is no operational difference between the pins.

**EXTERNAL REFERENCED OUTPUT**

Tying both pins together and to a reference produces an output equal to the reference voltage when there is no differential input (see Figure 29). The output decreases the reference voltage when the input is negative, relative to the  $-IN$  pin, and increases when the input is positive, relative to the  $-IN$  pin.

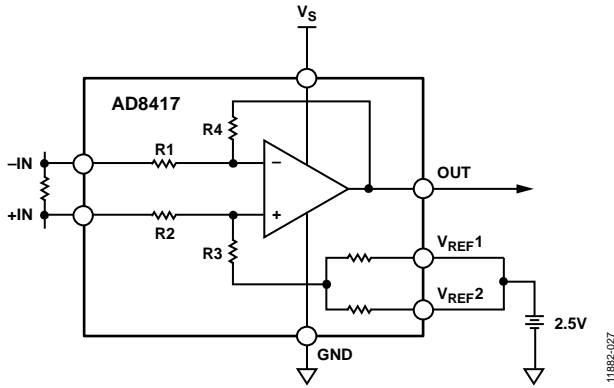

Figure 29. External Referenced Output

**SPLITTING THE SUPPLY**

By tying one reference pin to  $V_s$  and the other to GND, the output is set at half of the supply when there is no differential input (see Figure 30). The benefit of this configuration is that an external reference is not required to offset the output for bidirectional current measurement. Tying one reference pin to  $V_s$  and the other to GND creates a midscale offset that is ratiometric to the supply, which means that if the supply increases or decreases, the output remains at half the supply. For example, if the supply is 5.0 V, the output is at half scale, or 2.5 V. If the supply increases by 10% (to 5.5 V), the output increases to 2.75 V.

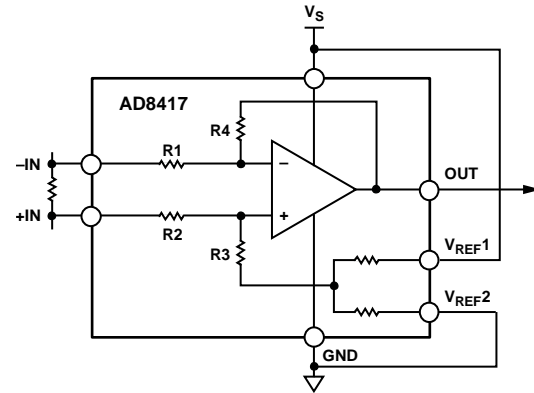

Figure 30. Split Supply

**SPLITTING AN EXTERNAL REFERENCE**

Use the internal reference resistors to divide an external reference by 2 with an accuracy of approximately 0.2%. Split an external reference by connecting one  $V_{REFX}$  pin to ground and the other  $V_{REFX}$  pin to the reference (see Figure 31).

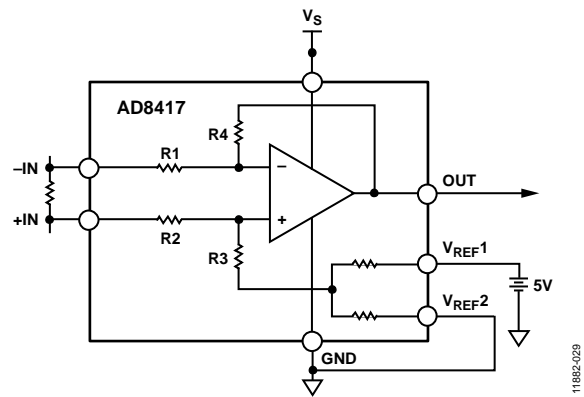

Figure 31. Split External Reference

# APPLICATIONS INFORMATION

## MOTOR CONTROL

### 3-Phase Motor Control

The AD8417 is ideally suited for monitoring current in 3-phase motor applications.

The 250 kHz typical bandwidth of the AD8417 provides instantaneous current monitoring. Additionally, the typical low offset drift of  $0.1 \mu\text{V}/^\circ\text{C}$  means that the measurement error between the two motor phases is at a minimum over temperature. The AD8417 rejects PWM input common-mode voltages in the  $-2 \text{ V}$  to  $+70 \text{ V}$  (with a 5 V supply) range. Monitoring the current on the motor phase allows sampling of the current at any point and provides diagnostic information, such as a short to GND and the battery. Refer to Figure 33 for the typical phase current measurement setup with the AD8417.

### H-Bridge Motor Control

Another typical application for the AD8417 is to form part of the control loop in H-bridge motor control. In this case, place the shunt resistor in the middle of the H-bridge to accurately measure current in both directions by using the shunt available at the motor (see Figure 32). Using an amplifier and shunt in this location is a better solution than a ground referenced op amp because ground is not typically a stable reference voltage

in this type of application. The instability of the ground reference causes inaccuracies in the measurements that can be made with a simple ground referenced op amp. The AD8417 measures current in both directions as the H-bridge switches and the motor changes direction. The output of the AD8417 is configured in an external referenced bidirectional mode (see the Bidirectional Operation section).

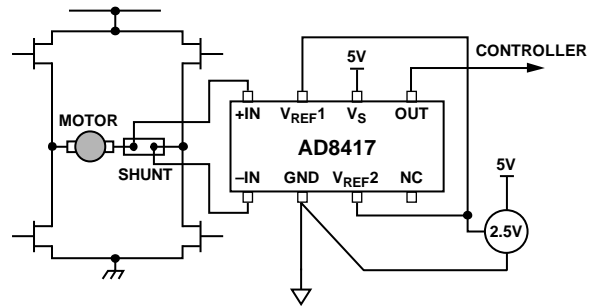

Figure 32. H-Bridge Motor Control

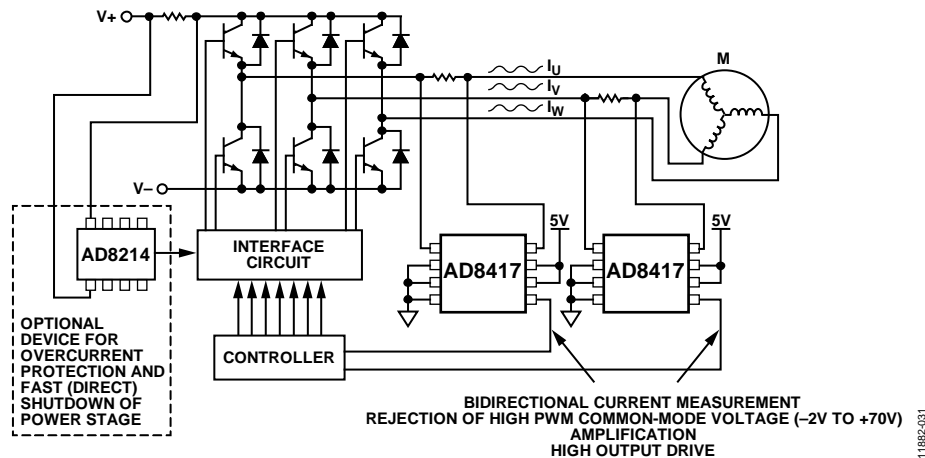

Figure 33. 3-Phase Motor Control

**SOLENOID CONTROL**

**High-Side Current Sense with a Low-Side Switch**

In the case of a high-side current sense with a low-side switch, the PWM control switch is ground referenced. Tie an inductive load (solenoid) to a power supply and place a resistive shunt between the switch and the load (see Figure 34). An advantage of placing the shunt on the high side is that the entire current, including the recirculation current, is measurable because the shunt remains in the loop when the switch is off. In addition, diagnostics are enhanced because shorts to ground are detected with the shunt on the high side.

In this circuit configuration, when the switch is closed, the common-mode voltage decreases to near the negative rail. When the switch is open, the voltage reversal across the inductive load causes the common-mode voltage to be held one diode drop above the battery by the clamp diode.

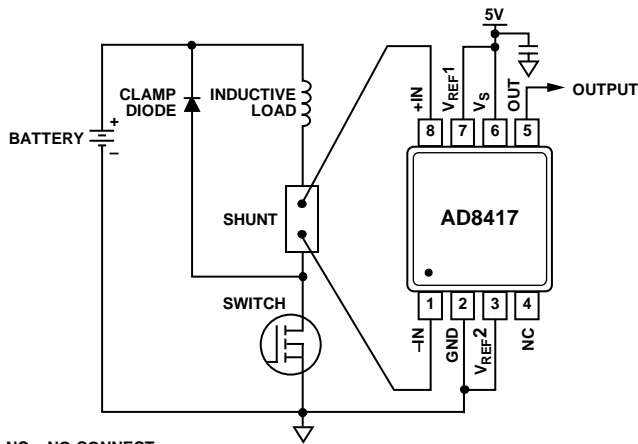

NC = NO CONNECT.

Figure 34. Low-Side Switch

**High-Side Current Sense with a High-Side Switch**

The high-side current sense with a high-side switch configuration minimizes the possibility of unexpected solenoid activation and excessive corrosion (see Figure 35). In this case, both the switch and the shunt are on the high side. When the switch is off, the battery is removed from the load, which prevents damage from potential shorts to ground while still allowing the recirculating current to be measured and to provide diagnostics. Removing the power supply from the load for the majority of the time that the switch is open minimizes the corrosive effects that can be caused by the differential voltage between the load and ground.

When using a high-side switch, the battery voltage is connected to the load when the switch is closed, causing the common-mode voltage to increase to the battery voltage. In this case, when the switch is open, the voltage reversal across the inductive load causes the common-mode voltage to be held one diode drop below ground by the clamp diode.

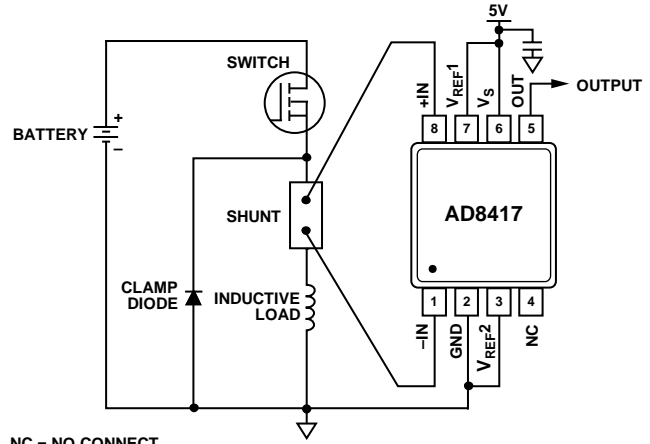

NC = NO CONNECT.

Figure 35. High-Side Switch

**High Rail Current Sensing**

In the high rail current sensing configuration, the shunt resistor is referenced to the battery. High voltage is present at the inputs of the current sense amplifier. When the shunt is battery referenced, the AD8417 produces a linear ground referenced analog output. Additionally, the AD8214 provides an overcurrent detection signal in as little as 100 ns (see Figure 36). This feature is useful in high current systems where fast shutdown in overcurrent conditions is essential.

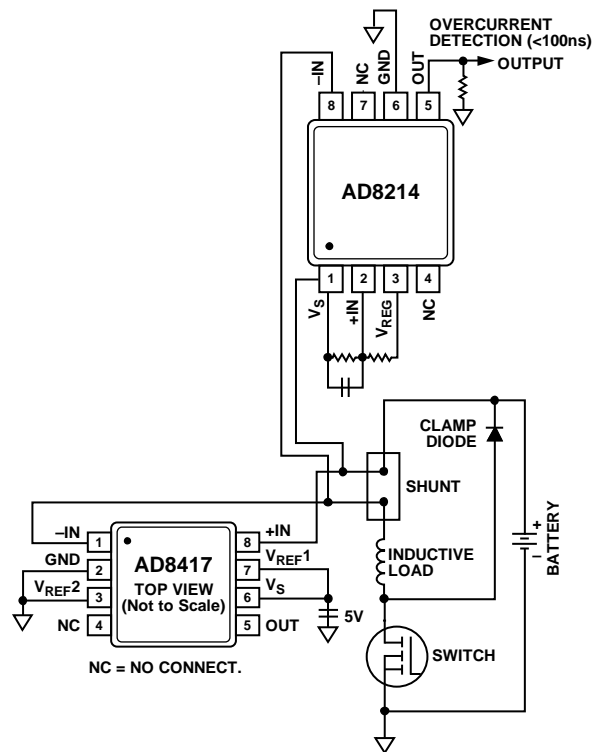

NC = NO CONNECT.

Figure 36. High Rail Current Sensing

**PINOUT OPTION ENGINEERED FOR FMEA**

The AD8417 is available in a 10-lead MSOP pinout option engineered for FMEA. This FMEA tolerant pinout is designed to meet stringent automotive requirements and to conditionally survive single faults due to common printed circuit board (PCB) defects, as described in Table 6. NC pins have been

inserted between  $-IN$  and GND, as well as between  $+IN$  and  $V_{REF1}$ . These NC pins effectively isolate the voltages at the input pins, which may range from  $-2\text{ V}$  to  $+70\text{ V}$ , from adjacent pins, preventing the occurrence of unrecoverable faults.

**Table 6. Behavior Due to the Adjacent Pin to Pin Shorts**

| Pin No. | Adjacent Pins Shorted | Behavior   |
|---------|-----------------------|--|
| 1, 2    | $-IN$ and NC          | The circuit behaves normally.  |
| 2, 3    | NC and GND            | The circuit behaves normally.  |
| 3, 4    | GND and $V_{REF2}$    | The AD8417 can handle a short between these two pins as long as $V_{REF2}$ is not lower than GND or higher than $V_S$ . For example, if the AD8417 references are configured to split the supply with $V_{REF2}$ tied to GND, the circuit behaves normally. There is a system error, however, if $V_{REF2}$ is tied to $V_S$ or to a different external reference because GND is then shorted to $V_S$ or to the external reference voltage on the PCB.  |
| 4, 5    | $V_{REF2}$ and NC     | The circuit behaves normally.  |
| 6, 7    | OUT and $V_S$         | OUT approaches $V_S$ voltage.  |
| 7, 8    | $V_S$ and $V_{REF1}$  | The AD8417 can handle a short between these two pins as long as $V_{REF1}$ is not lower than GND or higher than $V_S$ . For example, if the AD8417 references are configured to split the supply with $V_{REF1}$ tied to $V_S$ , the circuit behaves normally. There is a system error, however, if $V_{REF1}$ is tied to GND or to a different external reference because $V_S$ is then shorted to GND or to the external reference voltage on the PCB. |
| 8, 9    | $V_{REF1}$ and NC     | The circuit behaves normally.  |
| 9, 10   | NC and $+IN$          | The circuit behaves normally.  |

OUTLINE DIMENSIONS

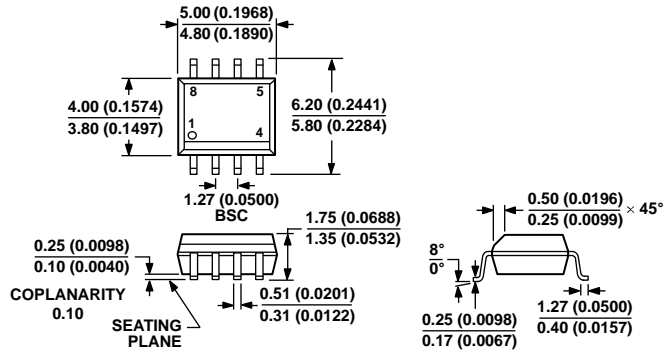

COMPLIANT TO JEDEC STANDARDS MS-012-AA  
 CONTROLLING DIMENSIONS ARE IN MILLIMETERS; INCH DIMENSIONS  
 (IN PARENTHESES) ARE ROUNDED-OFF MILLIMETER EQUIVALENTS FOR  
 REFERENCE ONLY AND ARE NOT APPROPRIATE FOR USE IN DESIGN.

Figure 37. 8-Lead Standard Small Outline Package [SOIC\_N]  
 Narrow Body  
 (R-8)  
 Dimensions shown in millimeters and (inches)

012407-A

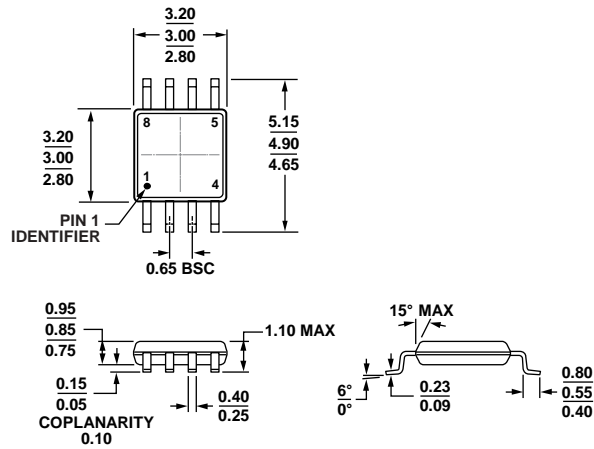

COMPLIANT TO JEDEC STANDARDS MO-187-AA  
 Figure 38. 8-Lead Mini Small Outline Package [MSOP]  
 (RM-8)  
 Dimensions shown in millimeters

10-07-2008-B

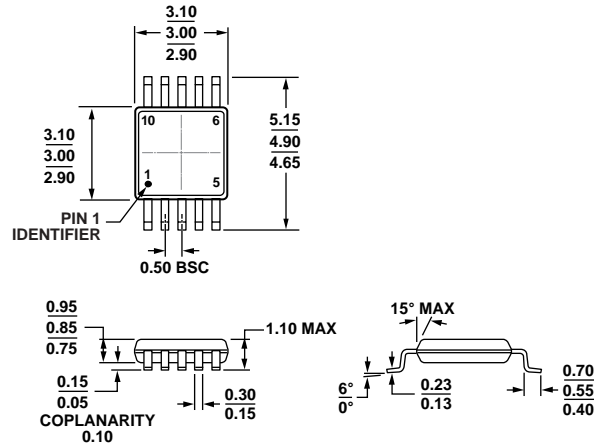

COMPLIANT TO JEDEC STANDARDS MO-187-BA  
 Figure 39. 10-Lead Mini Small Outline Package [MSOP] (RM-10)  
 Dimensions shown in millimeters

**ORDERING GUIDE**

| Model <sup>1,2</sup> | Temperature Range | Package Description              | Package Option | Marking Code |
|----------------------|-------------------|----------------------------------|----------------|--------------|
| AD8417BRMZ           | -40°C to +125°C   | 8-Lead MSOP                      | RM-8           | Y4Y          |
| AD8417BRMZ-RL        | -40°C to +125°C   | 8-Lead MSOP, 13" Tape and Reel   | RM-8           | Y4Y          |
| AD8417WBRMZ          | -40°C to +125°C   | 8-Lead MSOP                      | RM-8           | Y4X          |
| AD8417WBRMZ-RL       | -40°C to +125°C   | 8-Lead MSOP, 13" Tape and Reel   | RM-8           | Y4X          |
| AD8417WBRZ           | -40°C to +125°C   | 8-Lead SOIC_N                    | R-8            |              |
| AD8417WBRZ-RL        | -40°C to +125°C   | 8-Lead SOIC_N, 13" Tape and Reel | R-8            |              |
| AD8417WHRZ           | -40°C to +150°C   | 8-Lead SOIC_N                    | R-8            |              |
| AD8417WHRZ-RL        | -40°C to +150°C   | 8-Lead SOIC_N, 13" Tape and Reel | R-8            |              |
| AD8417WHRMZ          | -40°C to +150°C   | 8-Lead MSOP                      | RM-8           | Y59          |
| AD8417WHRMZ-RL       | -40°C to +150°C   | 8-Lead MSOP, 13" Tape and Reel   | RM-8           | Y59          |
| AD8417WBRMZ-10       | -40°C to +125°C   | 10-Lead MSOP                     | RM-10          | A3Y          |
| AD8417WBRMZ-10RL     | -40°C to +125°C   | 10-Lead MSOP, 13" Tape and Reel  | RM-10          | A3Y          |
| AD8417R-EVALZ        |                   | 8-Lead SOIC_N Evaluation Board   |                |              |
| AD8417RM-EVALZ       |                   | 8-Lead MSOP Evaluation Board     |                |              |

<sup>1</sup> Z = RoHS Compliant Part.  
<sup>2</sup> W = Qualified for Automotive Applications.

**AUTOMOTIVE PRODUCTS**

The AD8417W models are available with controlled manufacturing to support the quality and reliability requirements of automotive applications. Note that these automotive models may have specifications that differ from the commercial models; therefore, designers should review the Specifications section of this data sheet carefully. Only the automotive grade products shown are available for use in automotive applications. Contact your local Analog Devices account representative for specific product ordering information and to obtain the specific Automotive Reliability reports for these models.

## Looking for pricing, stock, or lifecycle information?

Click below to explore more details on WIN SOURCE:

 [View AD8417WHRMZ-RL on WIN SOURCE](#)

 [Analog Devices Inc. Information](#)

## Optimize Your Supply Chain with WIN SOURCE Solutions

-  Global Sourcing Solution
-  Obsolete Management
-  Cost Control Management
-  Shortage Management
-  Alternative Solution
-  Excess Inventory Management