



# THE DATASHEET OF INA206AIDGST



## INA20x Unidirectional Measurement Current-Shunt Monitor With Dual Comparators

### 1 Features

- Complete Current Sense Solution
- Three Gain Options Available:
  - INA206 = 20 V/V
  - INA207 = 50 V/V
  - INA208 = 100 V/V
- Dual Comparators:
  - Comparator 1 With Latch
  - Comparator 2 With Optional Delay
- Common-mode Range: –16 V to 80 V
- High Accuracy: 3.5% (Maximum) Over Temperature
- Bandwidth: 500 kHz
- Quiescent Current: 1.8 mA
- Packages: SO-14, TSSOP-14, VSSOP-10

### 2 Applications

- Notebook Computers
- Cell Phones
- Telecom Equipment
- Automotive
- Power Management
- Battery Chargers
- Welding Equipment

### 3 Description

The INA206, INA207, and INA208 are a family of unidirectional current-shunt monitors with voltage output, dual comparators, and voltage reference. The INA206, INA207, and INA208 can sense drops across shunts at a common-mode voltages from –16 V to 80 V. The INA206, INA207, and INA208 are available with three output voltage scales: 20 V/V, 50 V/V, and 100 V/V, with up to 500-kHz bandwidth.

The INA206, INA207, and INA208 also incorporates two open-drain comparators with internal 0.6-V references. On 14-pin versions, the comparator references can be overridden by external inputs. Comparator 1 includes a latching capability, and Comparator 2 has a user-programmable delay on 14-pin versions. The 14-pin versions also provide a 1.2 V reference output.

The INA206, INA207, and INA208 operate from a single 2.7-V to 18-V supply. They are specified over the extended operating temperature range of –40°C to 125°C.

#### Device Information (1)

PART NUMBER	PACKAGE	BODY SIZE (NOM)
INA206	SOIC (14)	8.65 mm x 3.91 mm
INA207	TSSOP (14)	5.00 mm x 4.40 mm
INA208	VSSOP (10)	3.00 mm x 3.00 mm

(1) For all available packages, see the orderable addendum at the end of the data sheet.

#### Simplified Schematic

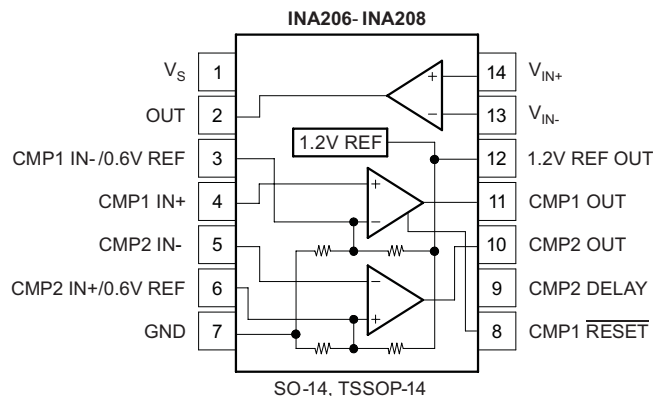

## Table of Contents

<b>1 Features</b> .....	<b>1</b>	8.2 Functional Block Diagram .....	<b>15</b>
<b>2 Applications</b> .....	<b>1</b>	8.3 Feature Description.....	<b>15</b>
<b>3 Description</b> .....	<b>1</b>	8.4 Device Functional Modes.....	<b>19</b>
<b>4 Revision History</b> .....	<b>2</b>	<b>9 Application and Implementation</b> .....	<b>22</b>
<b>5 Device Comparison Table</b> .....	<b>3</b>	9.1 Application Information.....	<b>22</b>
<b>6 Pin Configuration and Functions</b> .....	<b>3</b>	9.2 Typical Application .....	<b>22</b>
<b>7 Specifications</b> .....	<b>5</b>	<b>10 Power Supply Recommendations</b> .....	<b>25</b>
7.1 Absolute Maximum Ratings .....	<b>5</b>	<b>11 Layout</b> .....	<b>26</b>
7.2 ESD Ratings.....	<b>5</b>	11.1 Layout Guidelines .....	<b>26</b>
7.3 Recommended Operating Conditions.....	<b>5</b>	11.2 Layout Example .....	<b>26</b>
7.4 Thermal Information .....	<b>5</b>	<b>12 Device and Documentation Support</b> .....	<b>27</b>
7.5 Electrical Characteristics: Current-Shunt Monitor .....	<b>6</b>	12.1 Related Links .....	<b>27</b>
7.6 Electrical Characteristics: Comparator.....	<b>7</b>	12.2 Community Resources.....	<b>27</b>
7.7 Electrical Characteristics: Reference .....	<b>8</b>	12.3 Trademarks .....	<b>27</b>
7.8 Electrical Characteristics: General.....	<b>8</b>	12.4 Electrostatic Discharge Caution.....	<b>27</b>
7.9 Typical Characteristics .....	<b>10</b>	12.5 Glossary .....	<b>27</b>
<b>8 Detailed Description</b> .....	<b>15</b>	<b>13 Mechanical, Packaging, and Orderable Information</b> .....	<b>27</b>
8.1 Overview .....	<b>15</b>		

## 4 Revision History

NOTE: Page numbers for previous revisions may differ from page numbers in the current version.

<b>Changes from Revision E (October 2007) to Revision F</b>	<b>Page</b>
<ul style="list-style-type: none"> <li>ESD Ratings table, Feature Description section, Device Functional Modes, Application and Implementation section, Power Supply Recommendations section, Layout section, Device and Documentation Support section, and Mechanical, Packaging, and Orderable Information section .....</li> </ul>	<b>1</b>

## 5 Device Comparison Table

DEVICE	GAIN
INA206	20 V/V
INA207	50 V/V
INA208	100 V/V

## 6 Pin Configuration and Functions

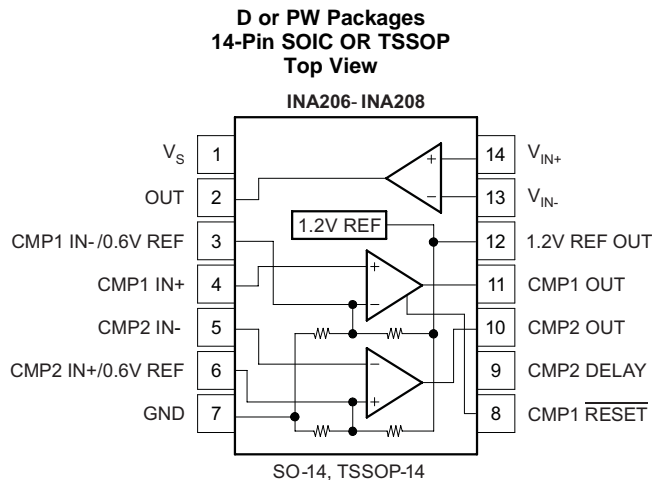

### Pin Functions: SOIC and TSSOP

PIN		I/O	DESCRIPTION
NO.	NAME		
1	Vs	I	Power Supply
2	OUT	O	Output voltage
3	CMP1 IN- /0.6V Ref	I	Comparator 1 negative input, can be used to override the internal 0.6-V reference
4	CMP1 IN+	I	Comparator 1 positive input
5	CMP2 IN-	I	Comparator 2 negative input
6	CMP2 IN+ /0.6V Ref	I	Comparator 2 positive input, can be used to override the internal 0.6-V reference
7	GND	I	Ground
8	<u>CMP1</u> RESET	I	Comparator 1 output reset, active low
9	CMP2 DELAY	I	Connect an optional capacitor to adjust comparator 2 delay
10	CMP2 OUT	O	Comparator 2 output
11	CMP1 OUT	O	Comparator 1 output
12	1.2V REF OUT	O	1.2-V reference output
13	VIN-	I	Connect to shunt low side
14	VIN+	I	Connect to shunt high side

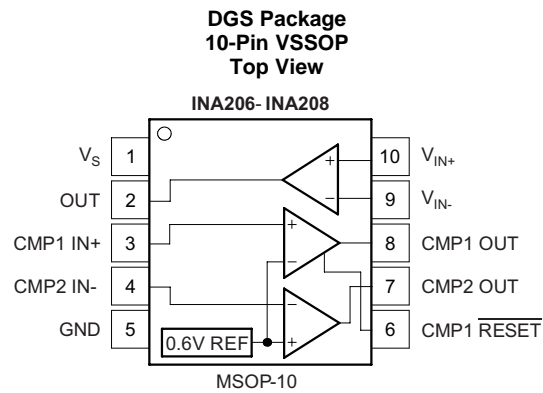
**Pin Functions: VSSOP**

PIN		I/O	DESCRIPTION
NO.	NAME		
1	V <sub>s</sub>	I	Power Supply
2	OUT	O	Output voltage
3	CMP1 IN+	I	Comparator 1 positive input
4	CMP2 IN-	I	Comparator 2 negative input
5	GND	I	Ground
6	<u>CMP1 RESET</u>	I	Comparator 1 output reset, active low
7	CMP2 OUT	O	Comparator 2 output
8	CMP1 OUT	O	Comparator 1 output
9	V <sub>IN-</sub>	I	Connect to shunt low side
10	V <sub>IN+</sub>	I	Connect to shunt high side

## 7 Specifications

### 7.1 Absolute Maximum Ratings

over operating free-air temperature range (unless otherwise noted) <sup>(1)</sup>

		MIN	MAX	UNIT
Supply voltage, $V_s$			18	V
Current-shunt monitor analog inputs, $V_{IN+}$ and $V_{IN-}$	Differential ( $V_{IN+} - V_{IN-}$ )	-18	18	V
	Common-Mode	-16	80	V
Comparator analog input and reset pins		GND - 0.3	$(V_s) + 0.3$	V
Analog output, out pin		GND - 0.3	$(V_s) + 0.3$	V
Comparator output, out pin		GND - 0.3	18	V
$V_{REF}$ and CMP2 delay pin		GND - 0.3	10	V
Input current into any pin			5	mA
Operating temperature		-55	150	°C
Junction temperature		-65	150	°C
Storage temperature, $T_{stg}$		-65	150	°C

- (1) Stresses beyond those listed under *Absolute Maximum Ratings* may cause permanent damage to the device. These are stress ratings only, which do not imply functional operation of the device at these or any other conditions beyond those indicated under *Recommended Operating Conditions*. Exposure to absolute-maximum-rated conditions for extended periods may affect device reliability.

### 7.2 ESD Ratings

		VALUE	UNIT
$V_{(ESD)}$ Electrostatic discharge	Human body model (HBM), per ANSI/ESDA/JEDEC JS-001 <sup>(1)</sup>	±4000	V
	Charged device model (CDM), per JEDEC specification JESD22-C101 <sup>(2)</sup>	±500	

- (1) JEDEC document JEP155 states that 500-V HBM allows safe manufacturing with a standard ESD control process.  
 (2) JEDEC document JEP157 states that 250-V CDM allows safe manufacturing with a standard ESD control process.

### 7.3 Recommended Operating Conditions

over operating free-air temperature range (unless otherwise noted)

	MIN	NOM	MAX	UNIT
$V_{cm}$ Common-mode input voltage	-16	12	80	V
$V_s$ Operating supply voltage	2.7	12	18	V
$T_A$ Operating free-air temperature	-40	25	125	°C

### 7.4 Thermal Information

THERMAL METRIC <sup>(1)</sup>	INA20x			UNIT
	D (SOIC)	DGS (VSSOP)	PW (TSSOP)	
	14 PINS	10 PINS	14 PINS	
$R_{\theta JA}$ Junction-to-ambient thermal resistance	84.9	161.3	112.6	°C/W
$R_{\theta JC(top)}$ Junction-to-case (top) thermal resistance	44	36.8	37.2	°C/W
$R_{\theta JB}$ Junction-to-board thermal resistance	39.4	82.3	55.4	°C/W
$\Psi_{JT}$ Junction-to-top characterization parameter	10.3	1.3	2.7	°C/W
$\Psi_{JB}$ Junction-to-board characterization parameter	39.1	80.8	54.7	°C/W
$R_{\theta JC(bot)}$ Junction-to-case (bottom) thermal resistance	150	200	150	°C/W

- (1) For more information about traditional and new thermal metrics, see the *Semiconductor and IC Package Thermal Metrics* application report, [SPRA953](#).

## 7.5 Electrical Characteristics: Current-Shunt Monitor

At  $T_A = 25^\circ\text{C}$ ,  $V_S = 12\text{ V}$ ,  $V_{IN+} = 12\text{ V}$ ,  $V_{SENSE} = 100\text{ mV}$ ,  $R_L = 10\text{ k}\Omega$  to GND,  $R_{PULL-UP} = 5.1\text{ k}\Omega$  each connected from CMP1 OUT and CMP2 OUT to  $V_S$ , and CMP1 IN+ = 1 V and CMP2 IN- = GND, unless otherwise noted.

PARAMETERS		TEST CONDITIONS	MIN	TYP	MAX	UNIT	
<b>INPUT</b>							
$V_{SENSE}$	Full-scale sense input voltage	$V_{SENSE} = V_{IN+} - V_{IN-}$		0.15	$(V_S - 0.25)/\text{Gain}$	V	
$V_{CM}$	Common-mode input range	$T_A = -40^\circ\text{C}$ to $125^\circ\text{C}$	-16		80	V	
CMRR	Common-mode rejection ratio	$V_{IN+} = -16\text{ V}$ to $80\text{ V}$	80	100		dB	
	Common-mode rejection ratio over temperature	$V_{IN+} = 12\text{ V}$ to $80\text{ V}$ , $T_A = -40^\circ\text{C}$ to $125^\circ\text{C}$	100		123	dB	
$V_{OS}$	Offset voltage RTI <sup>(1)</sup>	$T_A = 25^\circ\text{C}$		$\pm 0.5$	$\pm 2.5$	mV	
		$T_A = 25^\circ\text{C}$ to $125^\circ\text{C}$			$\pm 3$		
		$T_A = -40^\circ\text{C}$ to $25^\circ\text{C}$			$\pm 3.5$		
$dV_{OS}/dT$	Offset voltage RTI vs temperature	$T_A = -40^\circ\text{C}$ to $125^\circ\text{C}$		5		$\mu\text{V}/^\circ\text{C}$	
PSR	Offset voltage RTI vs power supply	$V_{OUT} = 2\text{ V}$ , $V_{IN+} = 18\text{ V}$ , $2.7\text{ V}$ , $T_A = -40^\circ\text{C}$ to $125^\circ\text{C}$		2.5	100	$\mu\text{V}/\text{V}$	
$I_B$	Input bias current, $V_{IN-}$ -Pin	$T_A = -40^\circ\text{C}$ to $125^\circ\text{C}$		$\pm 9$	$\pm 16$	$\mu\text{A}$	
<b>OUTPUT (<math>V_{SENSE} \geq 20\text{ mV}</math>)</b>							
G	Gain	INA206		20		V/V	
		INA207		50			
		INA208		100			
	Gain error	$V_{SENSE} = 20\text{ mV}$ to $100\text{ mV}$		$\pm 0.2\%$	$\pm 1\%$		
	Gain error over temperature	$V_{SENSE} = 20\text{ mV}$ to $100\text{ mV}$ , $T_A = -40^\circ\text{C}$ to $125^\circ\text{C}$			$\pm 2\%$		
	Total output error <sup>(2)</sup>	$V_{SENSE} = 120\text{ mV}$ , $V_S = 16\text{ V}$		$\pm 0.75\%$	$\pm 2.2\%$		
	Total output error over temperature	$V_{SENSE} = 120\text{ mV}$ , $V_S = 16\text{ V}$ , $T_A = -40^\circ\text{C}$ to $125^\circ\text{C}$			$\pm 3.5\%$		
	Nonlinearity error <sup>(3)</sup>	$V_{SENSE} = 20\text{ mV}$ to $100\text{ mV}$		$\pm 0.002\%$			
$R_O$	Output impedance			1.5		$\Omega$	
	Maximum capacitive load	No Sustained Oscillation		10		nF	
<b>OUTPUT (<math>V_{SENSE} &lt; 20\text{ mV}</math>) <sup>(4)</sup></b>							
Output voltage	Output voltage	INA206	$-16\text{ V} \leq V_{CM} < 0\text{ V}$	300		mV	
		INA207		300			
		INA208		300			
	Output voltage	Output voltage	INA206	$0\text{ V} \leq V_{CM} \leq V_S$ , $V_S = 5\text{ V}$		0.4	V
			INA207			1	
			INA208			2	
	Output voltage	Output voltage	INA206	$V_S < V_{CM} \leq 80\text{ V}$	300		mV
			INA207		300		
			INA208		300		
<b>VOLTAGE OUTPUT</b>							
	Output swing to the positive rail	$V_{IN-} = 11\text{ V}$ , $V_{IN+} = 12\text{ V}$ , $T_A = -40^\circ\text{C}$ to $125^\circ\text{C}$		$(V_S) - 0.15$	$(V_S) - 0.25$	V	
	Output swing to GND <sup>(5)</sup>	$V_{IN-} = 0\text{ V}$ , $V_{IN+} = -0.5\text{ V}$ , $T_A = -40^\circ\text{C}$ to $125^\circ\text{C}$		$(V_{GND}) + 0.004$	$(V_{GND}) + 0.05$	V	

(1) Offset is extrapolated from measurements of the output at 20 mV and 100 mV  $V_{SENSE}$ .

(2) Total output error includes effects of gain error and  $V_{OS}$ .

(3) Linearity is best fit to a straight line.

(4) For details on this region of operation, see the [Accuracy Variations as a Result of  \$V\_{SENSE}\$  and Common-Mode Voltage](#) section.

(5) Specified by design.

## Electrical Characteristics: Current-Shunt Monitor (continued)

At  $T_A = 25^\circ\text{C}$ ,  $V_S = 12\text{ V}$ ,  $V_{IN+} = 12\text{ V}$ ,  $V_{SENSE} = 100\text{ mV}$ ,  $R_L = 10\text{ k}\Omega$  to GND,  $R_{PULL-UP} = 5.1\text{ k}\Omega$  each connected from CMP1 OUT and CMP2 OUT to  $V_S$ , and CMP1 IN+ = 1 V and CMP2 IN– = GND, unless otherwise noted.

PARAMETERS	TEST CONDITIONS	MIN	TYP	MAX	UNIT
<b>FREQUENCY RESPONSE</b>					
Bandwidth	INA206	$C_{LOAD} = 5\text{ pF}$	500		kHz
	INA207		300		
	INA208		200		
Phase margin	$C_{LOAD} < 10\text{ pF}$		40		°
Slew rate			1		V/ $\mu\text{s}$
Settling time (1%)	$V_{SENSE} = 10\text{ mV}_{PP}$ to $100\text{ mV}_{PP}$ , $C_{LOAD} = 5\text{ pF}$		2		$\mu\text{s}$
<b>NOISE, RTI</b>					
Output voltage noise density			40		nV/ $\sqrt{\text{Hz}}$

## 7.6 Electrical Characteristics: Comparator

At  $T_A = 25^\circ\text{C}$ ,  $V_S = 12\text{ V}$ ,  $V_{IN+} = 12\text{ V}$ ,  $V_{SENSE} = 100\text{ mV}$ ,  $R_L = 10\text{ k}\Omega$  to GND,  $R_{PULL-UP} = 5.1\text{ k}\Omega$  each connected from CMP1 OUT and CMP2 OUT to  $V_S$ , unless otherwise noted.

PARAMETERS	TEST CONDITIONS	MIN	TYP	MAX	UNIT
<b>OFFSET VOLTAGE</b>					
Offset Voltage	Comparator Common-Mode Voltage = Threshold Voltage, <a href="#">Figure 1</a>		2		mV
Offset Voltage Drift, Comparator 1	$T_A = -40^\circ\text{C}$ to $125^\circ\text{C}$		$\pm 2$		$\mu\text{V}/^\circ\text{C}$
Offset Voltage Drift, Comparator 2	$T_A = -40^\circ\text{C}$ to $125^\circ\text{C}$		5.4		$\mu\text{V}/^\circ\text{C}$
Threshold	$T_A = 25^\circ\text{C}$	590	608	620	mV
Threshold over Temperature	$T_A = -40^\circ\text{C}$ to $125^\circ\text{C}$	586		625	mV
Hysteresis <sup>(1)</sup> , CMP1	$T_A = -40^\circ\text{C}$ to $85^\circ\text{C}$		-8		mV
Hysteresis <sup>(1)</sup> , CMP2	$T_A = -40^\circ\text{C}$ to $85^\circ\text{C}$		8		mV
<b>INPUT BIAS CURRENT <sup>(2)</sup></b>					
CMP1 IN+, CMP2 IN–			0.005	10	nA
CMP1 IN+, CMP2 IN– vs Temperature	$T_A = -40^\circ\text{C}$ to $125^\circ\text{C}$			15	nA
<b>INPUT IMPEDANCE</b>					
Pins 3 and 6 (14-pin packages only)			10		k $\Omega$
<b>INPUT RANGE</b>					
CMP1 IN+ and CMP2 IN–		0 V to $V_S - 1.5\text{ V}$			V
Pins 3 and 6 (14-pin packages only) (3)		0 V to $V_S - 1.5\text{ V}$			V
<b>OUTPUT</b>					
Large-signal differential voltage gain	CMP $V_{OUT}$ 1 V to 4 V, $R_L \geq 15\text{ k}\Omega$ connected to 5 V		200		V/mV
High-level output current	$V_{ID} = 0.4\text{ V}$ , $V_{OH} = V_S$		0.0001	1	$\mu\text{A}$
Low-level output voltage	$V_{ID} = -0.6\text{ V}$ , $I_{OL} = 2.35\text{ mA}$		220	300	mV
<b>RESPONSE TIME <sup>(3)</sup></b>					
Comparator 1	$R_L$ to 5 V, $C_L = 15\text{ pF}$ , 100-mV Input Step with 5-mV Overdrive		1.3		$\mu\text{s}$
Comparator 2	$R_L$ to 5 V, $C_L = 15\text{ pF}$ , 100-mV Input Step with 5-mV Overdrive, $C_{DELAY}$ Pin Open		1.3		$\mu\text{s}$
<b>RESET</b>					
RESET Threshold <sup>(4)</sup>			1.1		V
Logic Input Impedance			2		m $\Omega$
Minimum RESET Pulse Width			1.5		$\mu\text{s}$
RESET Propagation Delay			3		$\mu\text{s}$

(1) Hysteresis refers to the threshold (the threshold specification applies to a rising edge of a noninverting input) of a falling edge on the noninverting input of the comparator. See [Figure 1](#).

(2) Specified by design.

(3) The comparator response time specified is the interval between the input step function and the instant when the output crosses 1.4 V.

(4) RESET input has an internal 2 M $\Omega$  (typical) pull-down. Leaving RESET open results in a LOW state, with transparent comparator operation.

## Electrical Characteristics: Comparator (continued)

At  $T_A = 25^\circ\text{C}$ ,  $V_S = 12\text{ V}$ ,  $V_{IN+} = 12\text{ V}$ ,  $V_{SENSE} = 100\text{ mV}$ ,  $R_L = 10\text{ k}\Omega$  to GND,  $R_{PULL-UP} = 5.1\text{ k}\Omega$  each connected from CMP1 OUT and CMP2 OUT to  $V_S$ , unless otherwise noted.

PARAMETERS	TEST CONDITIONS	MIN	TYP	MAX	UNIT
Comparator 2 Delay Equation <sup>(5)</sup>			$C_{DELAY} = t_D/5$		$\mu\text{F}$
Comparator 2 Delay, $t_D$	$C_{DELAY} = 0.1\text{ }\mu\text{F}$		0.5		s

(5) The Comparator 2 delay applies to both rising and falling edges of the comparator output.

## 7.7 Electrical Characteristics: Reference

At  $T_A = 25^\circ\text{C}$ ,  $V_S = 12\text{ V}$ ,  $V_{IN+} = 12\text{ V}$ ,  $V_{SENSE} = 100\text{ mV}$ ,  $R_L = 10\text{ k}\Omega$  to GND,  $R_{PULL-UP} = 5.1\text{ k}\Omega$  each connected from CMP1 OUT and CMP2 OUT to  $V_S$ , unless otherwise noted.

PARAMETERS	TEST CONDITIONS	MIN	TYP	MAX	UNIT
<b>REFERENCE VOLTAGE</b>					
1.2 $V_{REFOUT}$ Output Voltage		1.188	1.2	1.212	V
$dV_{OUT}/dT$ Reference Drift	$T_A = -40^\circ\text{C}$ to $85^\circ\text{C}$		40	100	ppm/ $^\circ\text{C}$
0.6 $V_{REF}$ Output Voltage (Pins 3 and 6 of 14-pin packages only)			0.6		V
$dV_{OUT}/dT$ Reference Drift	$T_A = -40^\circ\text{C}$ to $85^\circ\text{C}$		40	100	ppm/ $^\circ\text{C}$
$dV_{OUT}/dI_{LOAD}$ LOAD REGULATION					
Sourcing	$0\text{ mA} < I_{SOURCE} < 0.5\text{ mA}$		0.4	2	mV/mA
Sinking	$0\text{ mA} < I_{SINK} < 0.5\text{ mA}$		0.4		mV/mA
$I_{LOAD}$ LOAD CURRENT	$T_A = -40^\circ\text{C}$ to $125^\circ\text{C}$		1		mA
$dV_{OUT}/dV_S$ LINE REGULATION	$2.7\text{ V} < V_S < 18\text{ V}$ , $T_A = -40^\circ\text{C}$ to $125^\circ\text{C}$		30		$\mu\text{V}/\text{V}$
<b>CAPACITIVE LOAD</b>					
Reference Output Maximum Capacitive Load	No Sustained Oscillations		10		nF
<b>OUTPUT IMPEDANCE</b>					
Pins 3 and 6 of 14-Pin Packages Only			10		k $\Omega$

## 7.8 Electrical Characteristics: General

At  $T_A = 25^\circ\text{C}$ ,  $V_S = 12\text{ V}$ ,  $V_{IN+} = 12\text{ V}$ ,  $V_{SENSE} = 100\text{ mV}$ ,  $R_L = 10\text{ k}\Omega$  to GND,  $R_{PULL-UP} = 5.1\text{ k}\Omega$  each connected from CMP1 OUT and CMP2 OUT to  $V_S$ , and CMP1 IN+ = 1 V and CMP2 IN- = GND, unless otherwise noted.

PARAMETERS	TEST CONDITIONS	MIN	TYP	MAX	UNIT
<b>POWER SUPPLY</b>					
$V_S$ Operating Power Supply	$T_A = -40^\circ\text{C}$ to $125^\circ\text{C}$	2.7		18	V
$I_Q$ Quiescent Current	$V_{OUT} = 2\text{ V}$		1.8	2.2	mA
	$V_{SENSE} = 0\text{ mV}$ , $T_A = -40^\circ\text{C}$ to $125^\circ\text{C}$			2.8	mA
Comparator Power-On Reset Threshold <sup>(1)</sup>			1.5		V
<b>TEMPERATURE</b>					
Specified Temperature Range		-40		125	$^\circ\text{C}$
Operating Temperature Range		-55		150	$^\circ\text{C}$
Storage Temperature Range		-65		150	$^\circ\text{C}$
$\theta_{JA}$ Thermal Resistance	MSOP-10 Surface-Mount		200		$^\circ\text{C}/\text{W}$
	SO-14, TSSOP-14 Surface-Mount		150		$^\circ\text{C}/\text{W}$

(1) The INA206, INA207, and INA208 are designed to power-up with the comparator in a defined reset state as long as CMP1  $\overline{\text{RESET}}$  is open or grounded. The comparator will be in reset as long as the power supply is below the voltage shown here. The comparator will assume a state based on the comparator input above this supply voltage. If CMP1  $\overline{\text{RESET}}$  is high at power-up, the comparator output comes up high and requires a reset to assume a low state, if appropriate.

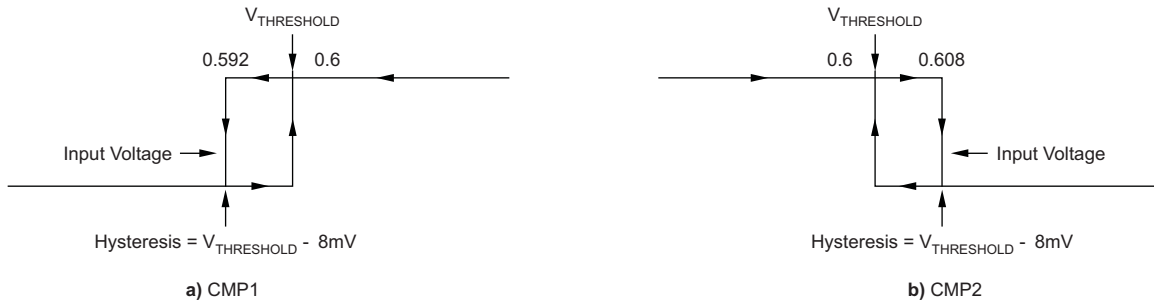

**Figure 1. Comparator Hysteresis**

## 7.9 Typical Characteristics

All specifications at  $T_A = 25^\circ\text{C}$ ,  $V_S = 12\text{ V}$ ,  $V_{IN+} = 12\text{ V}$ , and  $V_{SENSE} = 100\text{ mV}$ , unless otherwise noted.

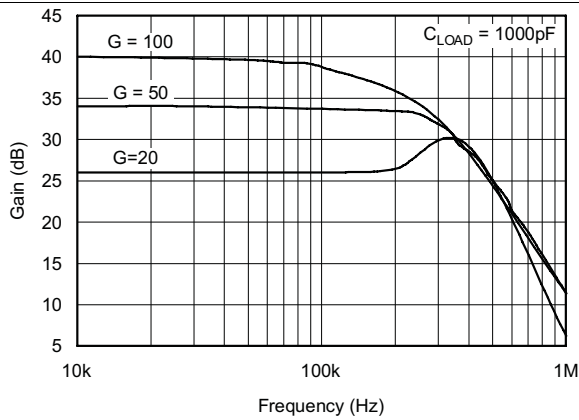

Figure 2. Gain vs Frequency

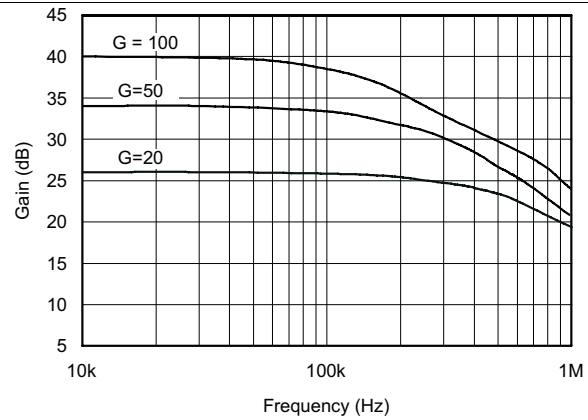

Figure 3. Gain vs Frequency

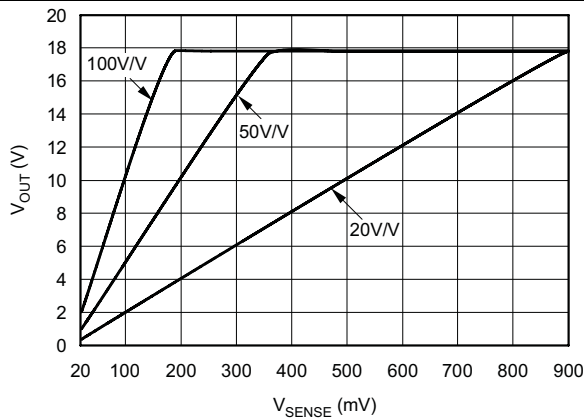

Figure 4. Gain Plot

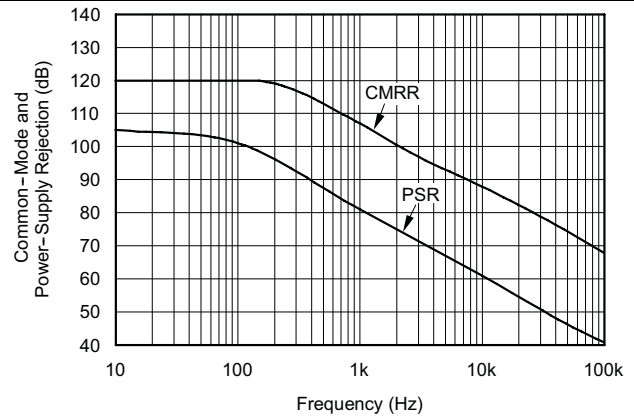

Figure 5. Common-Mode and Power-Supply Rejection vs Frequency

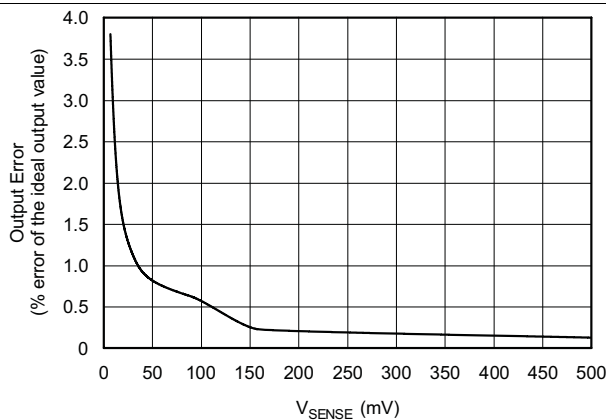

Figure 6. Output Error vs  $V_{SENSE}$

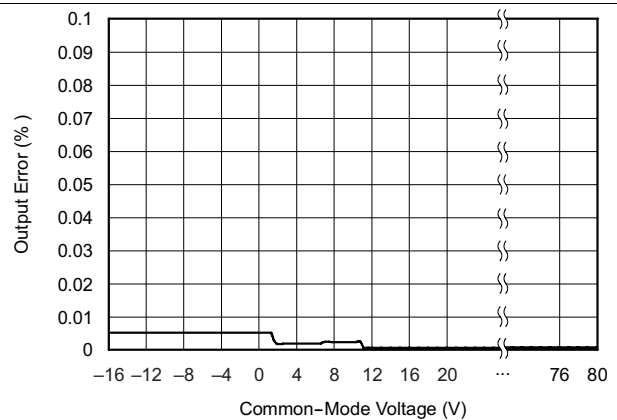

Figure 7. Output Error vs Common-Mode Voltage

Typical Characteristics (continued)

All specifications at  $T_A = 25^\circ\text{C}$ ,  $V_S = 12\text{ V}$ ,  $V_{IN+} = 12\text{ V}$ , and  $V_{SENSE} = 100\text{ mV}$ , unless otherwise noted.

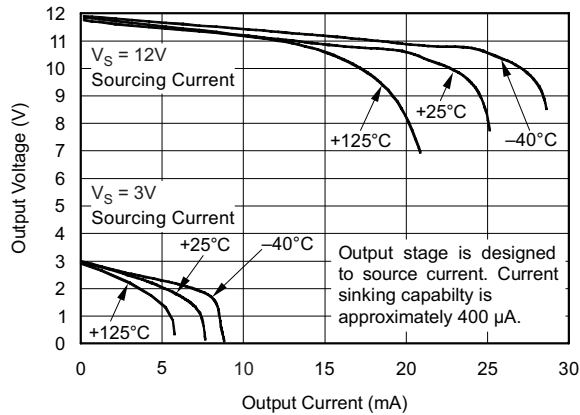

Figure 8. Positive Output Voltage Swing vs Output Current

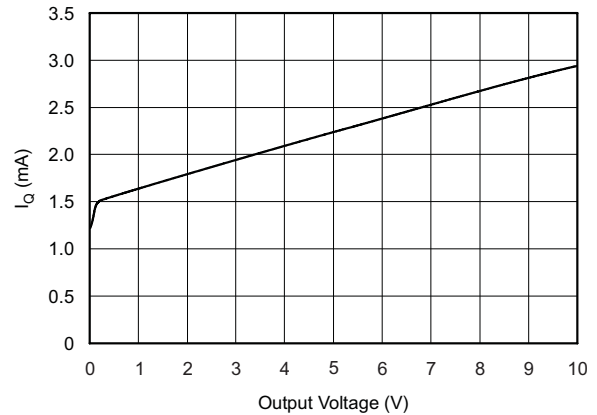

Figure 9. Quiescent Current vs Output Voltage

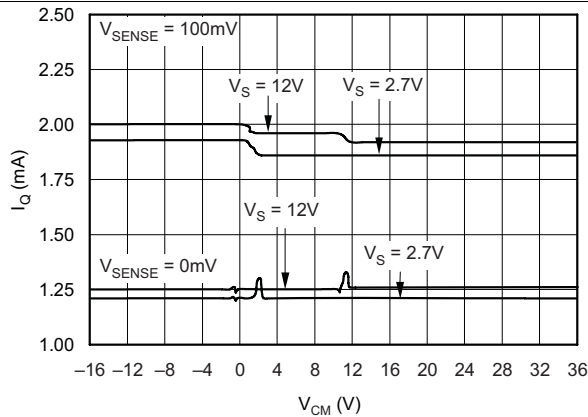

Figure 10. Quiescent Current vs Common-Mode Voltage

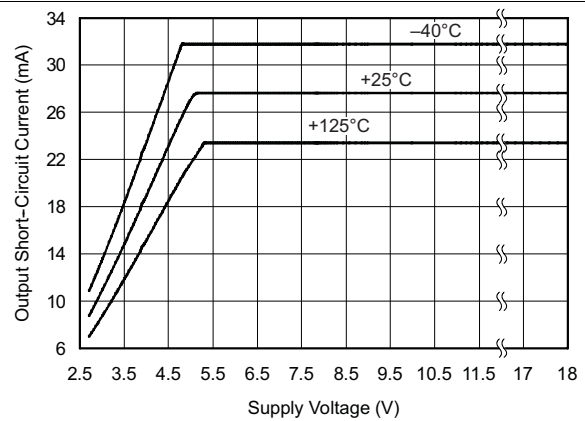

Figure 11. Output Short-Circuit Current vs Supply Voltage

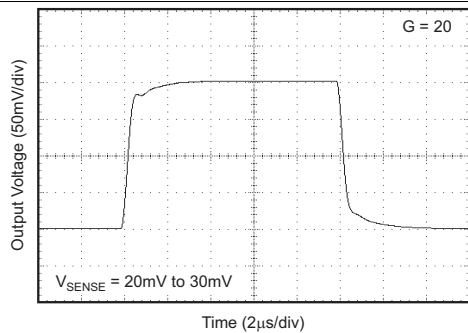

Figure 12. Step Response

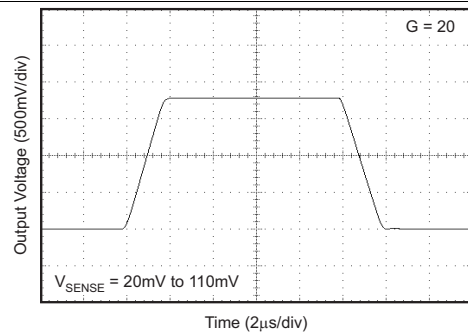

Figure 13. Step Response

Typical Characteristics (continued)

All specifications at  $T_A = 25^\circ\text{C}$ ,  $V_S = 12\text{ V}$ ,  $V_{IN+} = 12\text{ V}$ , and  $V_{SENSE} = 100\text{ mV}$ , unless otherwise noted.

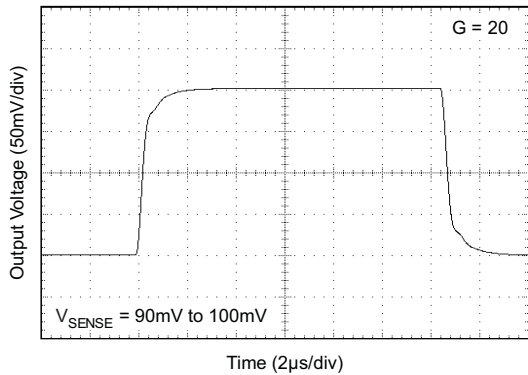

Figure 14. Step Response

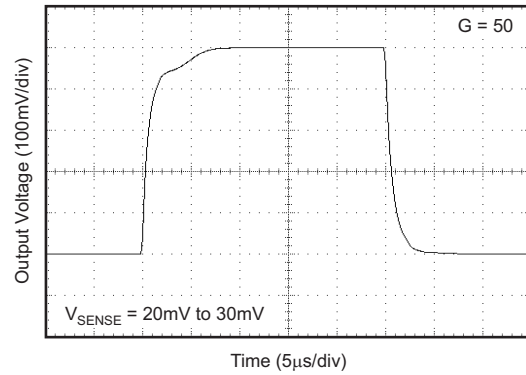

Figure 15. Step Response

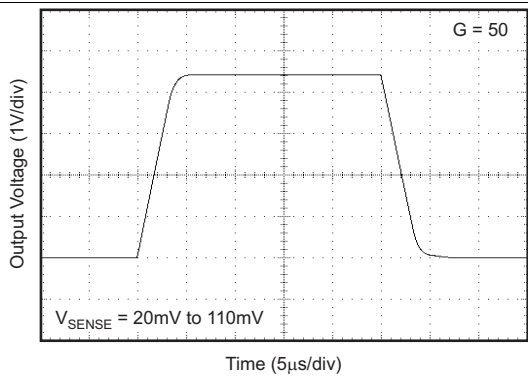

Figure 16. Step Response

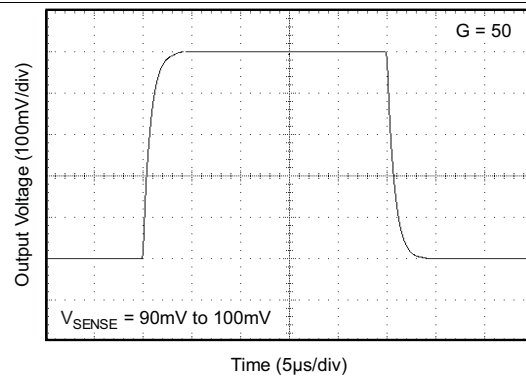

Figure 17. Step Response

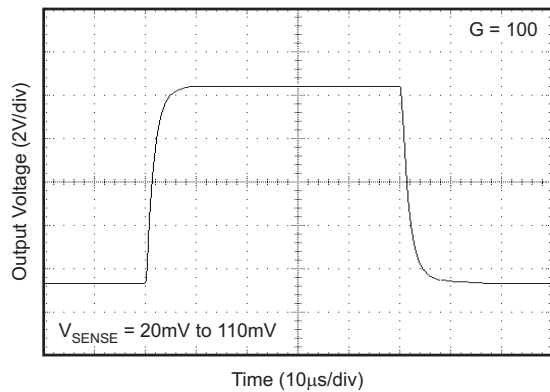

Figure 18. Step Response

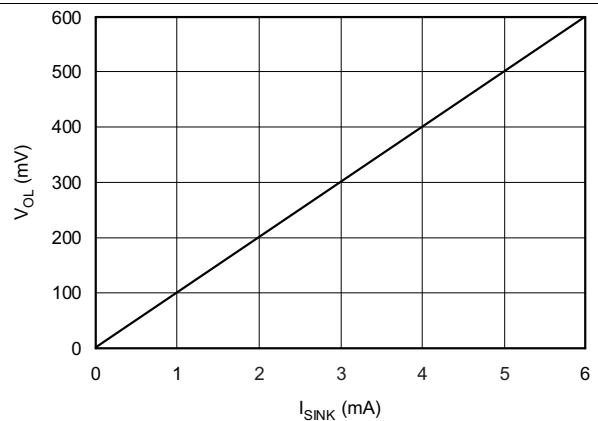

Figure 19. Comparator  $V_{OL}$  vs  $I_{SINK}$

Typical Characteristics (continued)

All specifications at  $T_A = 25^\circ\text{C}$ ,  $V_S = 12\text{ V}$ ,  $V_{IN+} = 12\text{ V}$ , and  $V_{SENSE} = 100\text{ mV}$ , unless otherwise noted.

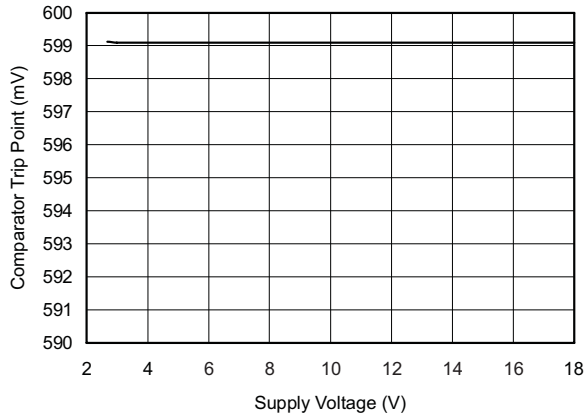

Figure 20. Comparator Trip Point vs Supply Voltage

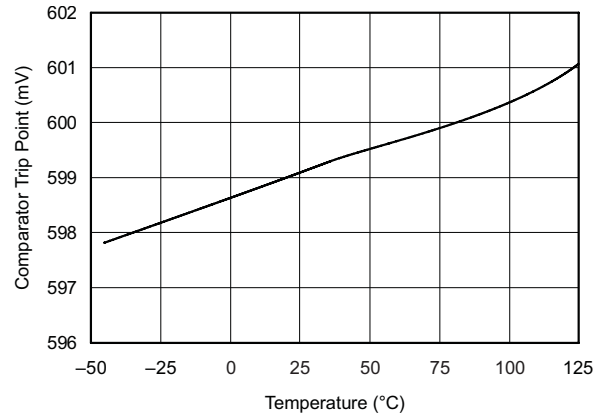

Figure 21. Comparator Trip Point vs Temperature

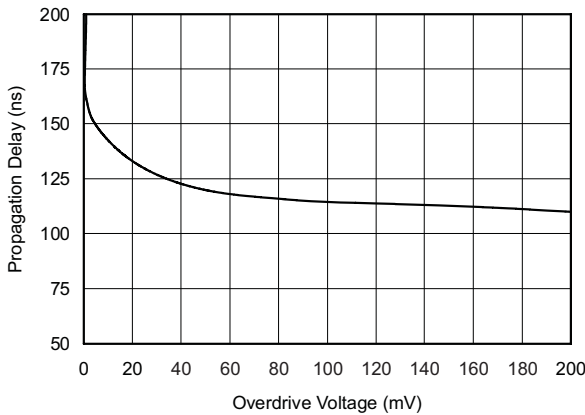

Figure 22. Comparator 1 Propagation Delay vs Overdrive Voltage

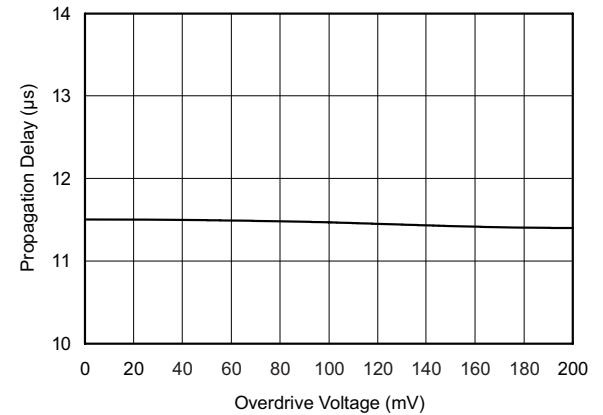

Figure 23. Comparator 2 Propagation Delay vs Overdrive Voltage

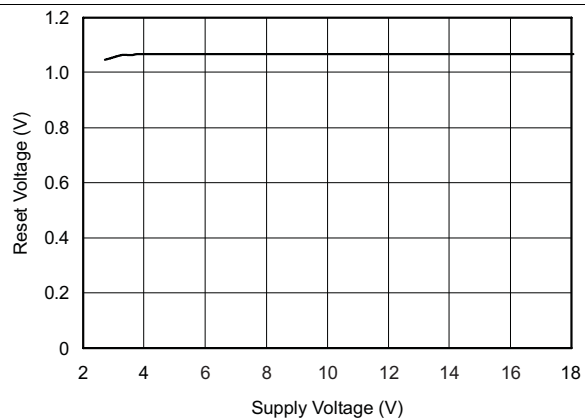

Figure 24. Comparator Reset Voltage vs Supply Voltage

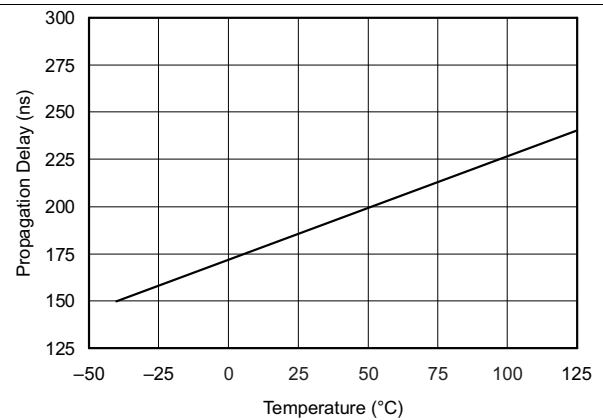

Figure 25. Comparator 1 Propagation Delay vs Temperature

### Typical Characteristics (continued)

All specifications at  $T_A = 25^\circ\text{C}$ ,  $V_S = 12\text{ V}$ ,  $V_{IN+} = 12\text{ V}$ , and  $V_{SENSE} = 100\text{ mV}$ , unless otherwise noted.

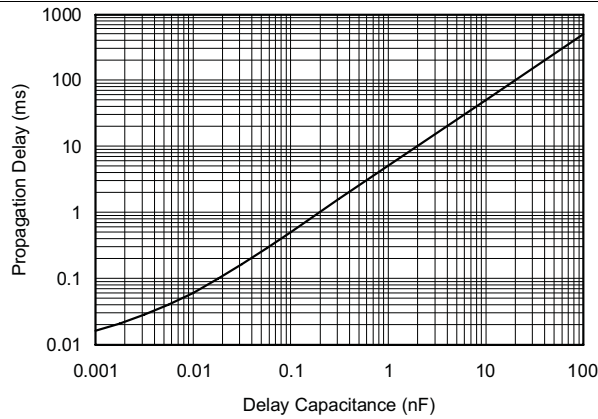

Figure 26. Comparator 2 Propagation Delay vs Capacitance

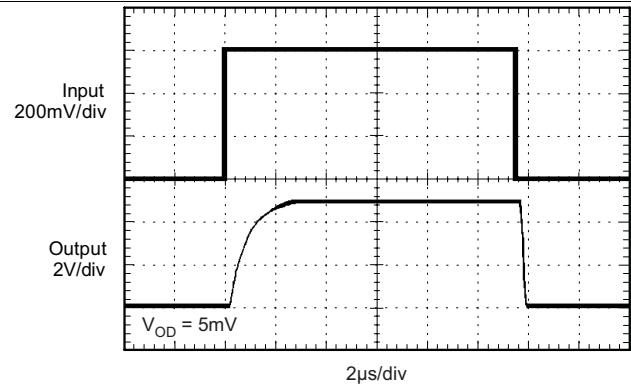

Figure 27. Comparator 1 Propagation Delay

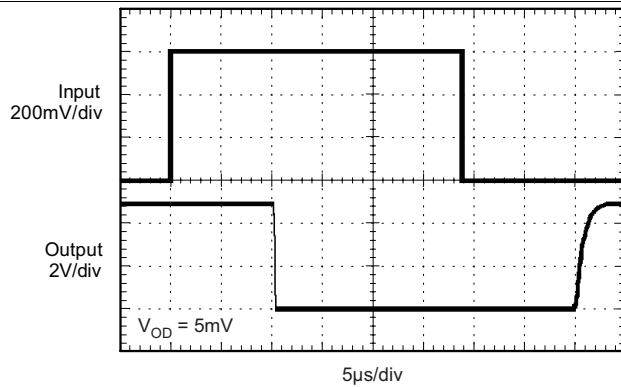

Figure 28. Comparator 2 Propagation Delay

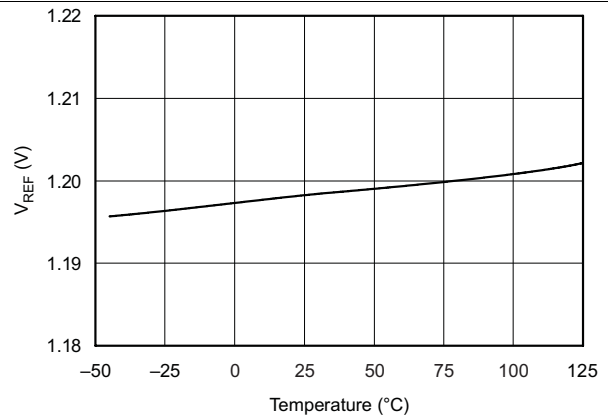

Figure 29. Reference Voltage vs Temperature

## 8 Detailed Description

### 8.1 Overview

The INA206, INA207, and INA208 are a family of unidirectional current-shunt monitors with voltage output, dual comparators, and voltage reference. The INA206, INA207, and INA208 can sense drops across shunts at common-mode voltages from  $-16\text{ V}$  to  $80\text{ V}$ . The INA206, INA207, and INA208 are available with three output voltage scales:  $20\text{ V/V}$ ,  $50\text{ V/V}$ , and  $100\text{ V/V}$ , with up to  $500\text{-kHz}$  bandwidth. The INA206, INA207, and INA208 also incorporate two open-drain comparators with internal  $0.6\text{-V}$  references. On 14-pin versions, the comparator references can be overridden by external inputs. Comparator 1 includes a latching capability, and Comparator 2 has a user-programmable delay. 14-pin versions also provide a  $1.2\text{-V}$  reference output. The INA206, INA207, and INA208 operate from a single  $2.7\text{-V}$  to  $18\text{-V}$  supply. They are specified over the extended operating temperature range of  $-40^{\circ}\text{C}$  to  $125^{\circ}\text{C}$ .

### 8.2 Functional Block Diagram

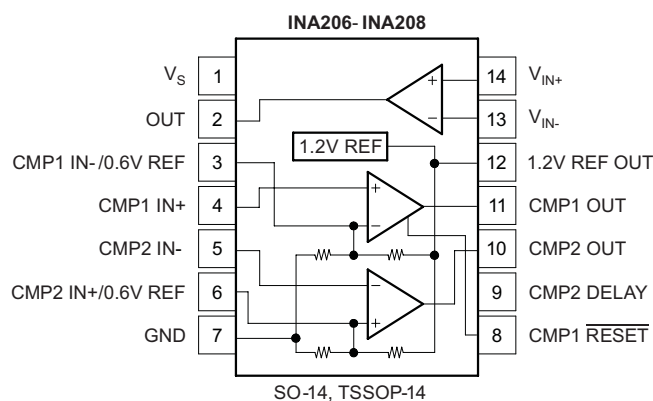

### 8.3 Feature Description

#### 8.3.1 Output Voltage Range

The output of the INA206, INA207, and INA208 is accurate within the output voltage swing range set by the power supply pin,  $V_S$ . This performance is best illustrated when using the INA208 (a gain of 100 version), where a  $100\text{-mV}$  full-scale input from the shunt resistor requires an output voltage swing of  $10\text{ V}$ , and a power-supply voltage sufficient to achieve  $10\text{ V}$  on the output.

#### 8.3.2 Reference

The INA206, INA207, and INA208 include an internal voltage reference that has a load regulation of  $0.4\text{ mV/mA}$  (typical), and not more than  $100\text{ ppm}/^{\circ}\text{C}$  of drift. Only the 14-pin package allows external access to reference voltages, where voltages of  $1.2\text{ V}$  and  $0.6\text{ V}$  are both available. Output current versus output voltage is illustrated in [Typical Characteristics](#).

#### 8.3.3 Comparator

The INA206, INA207, and INA208 devices incorporate two open-drain comparators. These comparators typically have  $2\text{ mV}$  of offset and a  $1.3\text{-}\mu\text{s}$  (typical) response time. The output of Comparator 1 latches and is reset through the  $\text{CMP1 RESET}$  pin, as shown in [Figure 31](#). This configuration applies to both the 10- and 14-pin versions. [Figure 30](#) illustrates the comparator delay.

The 14-pin versions of the INA206, INA207, and INA208 include additional features for comparator functions. The comparator reference voltage of both Comparator 1 and Comparator 2 can be overridden by external inputs for increased design flexibility. Comparator 2 has a programmable delay.

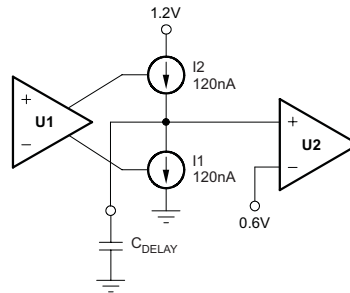
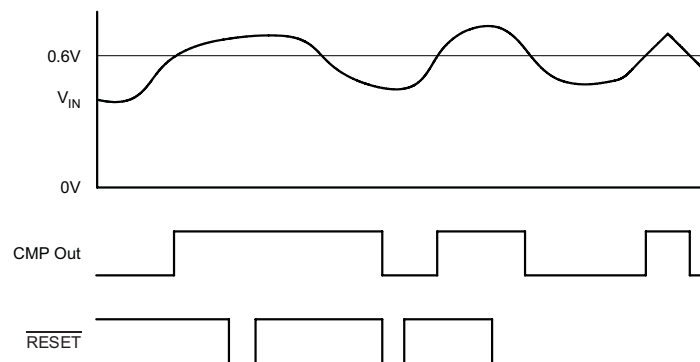
**Feature Description (continued)**

**Figure 30. Simplified Model of the Comparator 2 Delay Circuit**

**Figure 31. Comparator 1 Latching Capability**
**8.3.4 Comparator Delay (14-Pin Version Only)**

The Comparator 2 programmable delay is controlled by a capacitor connected to the CMP2 Delay Pin; see [Figure 40](#). The capacitor value (in  $\mu\text{F}$ ) is selected by using [Equation 1](#).

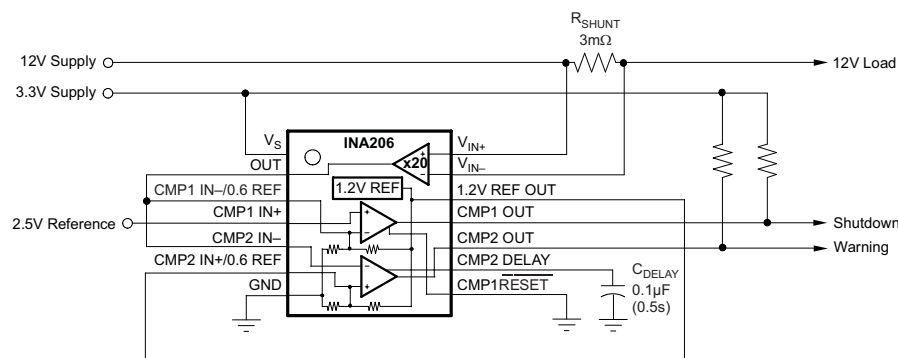
$$C_{\text{DELAY}} (\text{in } \mu\text{F}) = \frac{t_D}{5} \tag{1}$$

A simplified version of the delay circuit for Comparator 2 is shown in [Figure 30](#). The delay comparator consists of two comparator stages with the delay between them. Note that I1 and I2 cannot be turned on simultaneously; I1 corresponds to a U1 low output and I2 corresponds to a U1 high output. Using an initial assumption that the U1 output is low, I1 is on, then U2 +IN is zero. If U1 goes high, I2 supplies 120 nA to  $C_{\text{DELAY}}$ . The voltage at U2 +IN begins to ramp toward a 0.6-V threshold. When the voltage crosses this threshold, the U2 output goes high while the voltage at U2 +IN continues to ramp up to a maximum of 1.2 V when given sufficient time (twice the value of the delay specified for  $C_{\text{DELAY}}$ ). This entire sequence is reversed when the comparator outputs go low, so that returning to low exhibits the same delay.

**Figure 32. Server 12-V Supply Current Monitor**

**Feature Description (continued)**

It is important to note what will happen if events occur more rapidly than the delay timeout; for example, when the U1 output goes high (turning on I2), but returns low (turning I1 back on) prior to reaching the 0.6-V transition for U2. The voltage at U2 +IN ramps back down at a rate determined by the value of  $C_{DELAY}$ , and only returns to zero if given sufficient time.

In essence, when analyzing Comparator 2 for behavior with events more rapid than its delay setting, use the model shown in Figure 30.

**8.3.5 Comparator Maximum Input Voltage Range**

The maximum voltage at the comparator input for normal operation is up to  $(V_s) - 1.5$  V. There are special considerations when overdriving the reference inputs (pins 3 and 6). Driving either or both inputs high enough to drive 1 mA back into the reference introduces errors into the reference. Figure 33 shows the basic input structure. A general guideline is to limit the voltage on both inputs to a total of 20 V. The exact limit depends on the available voltage and whether either or both inputs are subject to the large voltage. When making this determination, consider the 20 kΩ from each input back to the comparator. Figure 34 shows the maximum input voltage that avoids creating a reference error when driving both inputs (an equivalent resistance back into the reference of 10 kΩ).

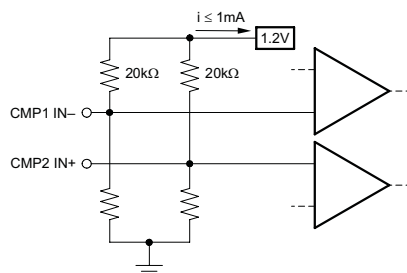

**Figure 33. Limit Current Into Reference  $\le 1$  mA**

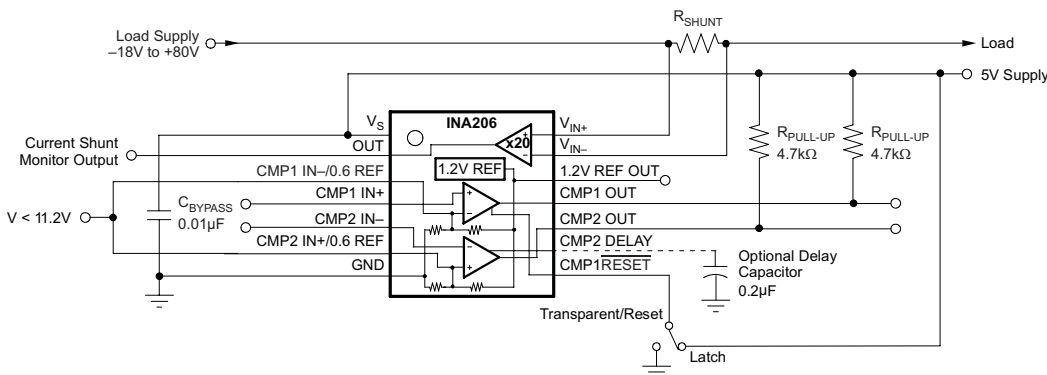

**Figure 34. Overdriving Comparator Inputs Without Generating a Reference Error**

Feature Description (continued)

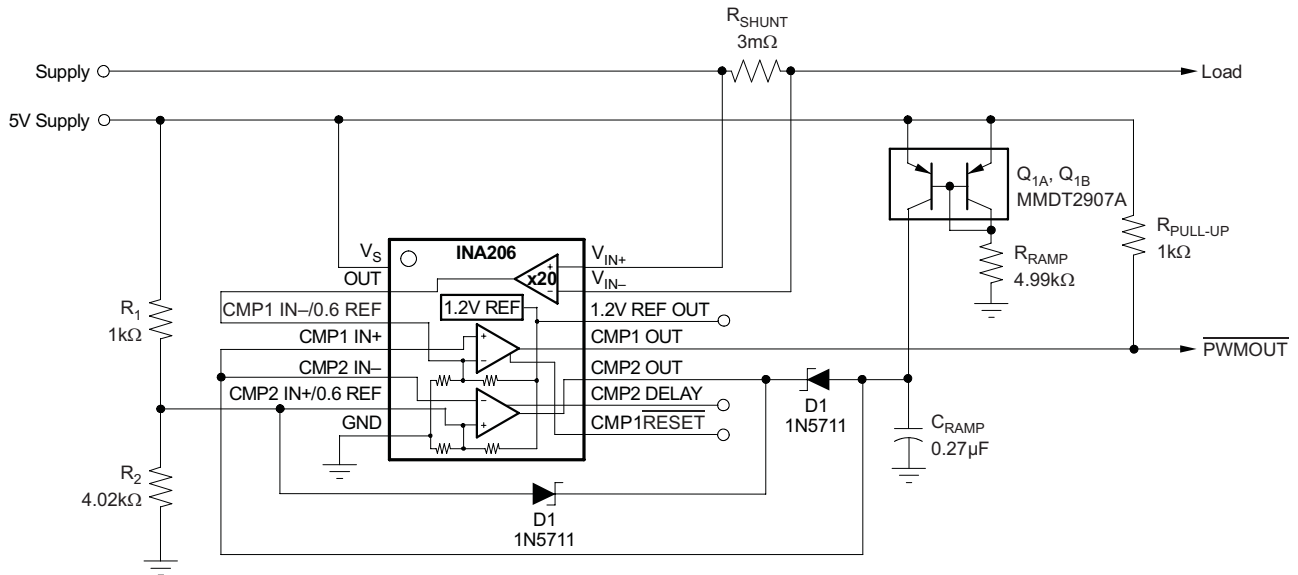

Figure 35. PWM Output Current-Shunt Monitor

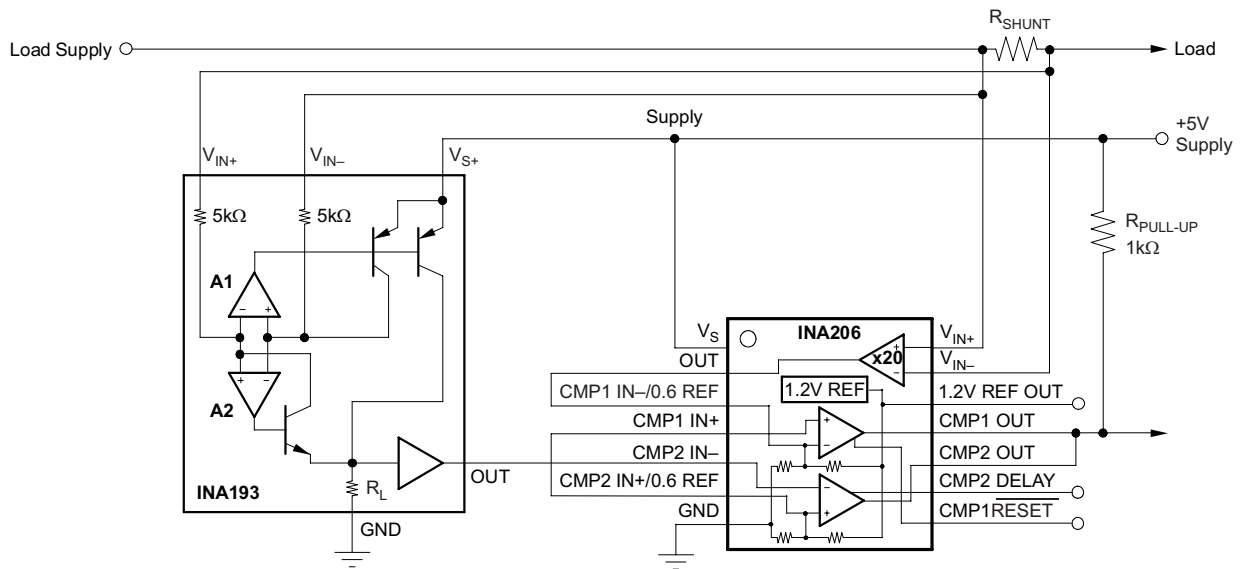

Figure 36. Bi-Directional Current Comparator

## Feature Description (continued)

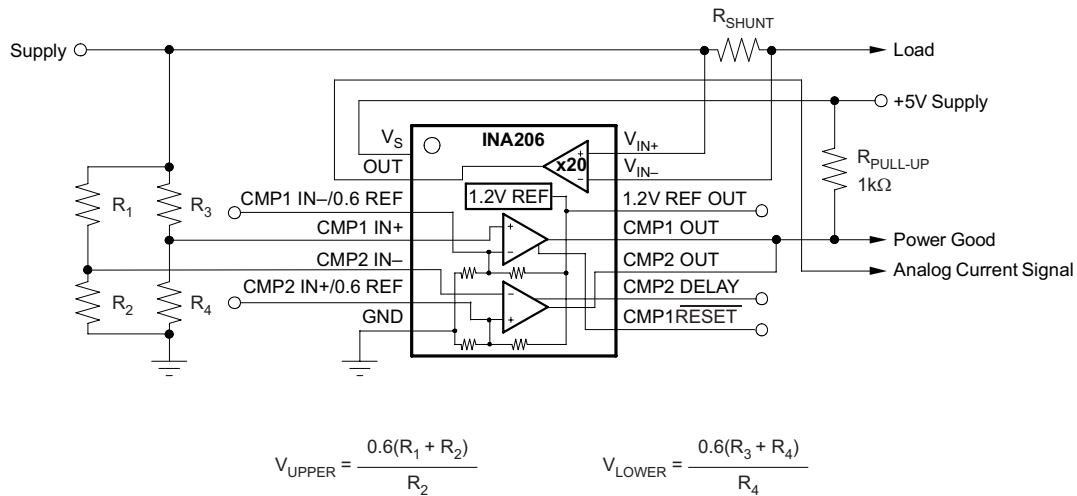

Figure 37. Analog Output Current-Shunt Monitor With Comparators Used as Power-Supply Under-Limit or Over-Limit or Power-Good Detector

## 8.4 Device Functional Modes

### 8.4.1 Accuracy Variations as a Result of $V_{\text{SENSE}}$ and Common-Mode Voltage

The accuracy of the INA206, INA207, and INA208 current-shunt monitors is a function of two main variables:  $V_{\text{SENSE}}$  ( $V_{\text{IN}+} - V_{\text{IN}-}$ ) and common-mode voltage,  $V_{\text{CM}}$ , relative to the supply voltage,  $V_{\text{S}}$ .  $V_{\text{CM}}$  is expressed as  $(V_{\text{IN}+} + V_{\text{IN}-})/2$ ; however, in practice,  $V_{\text{CM}}$  is seen as the voltage at  $V_{\text{IN}+}$  because the voltage drop across  $V_{\text{SENSE}}$  is usually small.

This section addresses the accuracy of these specific operating regions:

- Normal Case 1:  $V_{\text{SENSE}} \geq 20 \text{ mV}$ ,  $V_{\text{CM}} \geq V_{\text{S}}$
- Normal Case 2:  $V_{\text{SENSE}} \geq 20 \text{ mV}$ ,  $V_{\text{CM}} < V_{\text{S}}$
- Low  $V_{\text{SENSE}}$  Case 1:  $V_{\text{SENSE}} < 20 \text{ mV}$ ,  $-16 \text{ V} \leq V_{\text{CM}} < 0$
- Low  $V_{\text{SENSE}}$  Case 2:  $V_{\text{SENSE}} < 20 \text{ mV}$ ,  $0 \text{ V} \leq V_{\text{CM}} \leq V_{\text{S}}$
- Low  $V_{\text{SENSE}}$  Case 3:  $V_{\text{SENSE}} < 20 \text{ mV}$ ,  $V_{\text{S}} < V_{\text{CM}} \leq 80 \text{ V}$

#### 8.4.1.1 Normal Case 1: $V_{\text{SENSE}} \geq 20 \text{ mV}$ , $V_{\text{CM}} \geq V_{\text{S}}$

This region of operation provides the highest accuracy. Here, the input offset voltage is characterized and measured using a two-step method. First, the gain is determined by Equation 2.

$$G = \frac{V_{\text{OUT1}} - V_{\text{OUT2}}}{100 \text{ mV} - 20 \text{ mV}}$$

where

- $V_{\text{OUT1}}$  = Output Voltage with  $V_{\text{SENSE}} = 100 \text{ mV}$
- $V_{\text{OUT2}}$  = Output Voltage with  $V_{\text{SENSE}} = 20 \text{ mV}$

Then the offset voltage is measured at  $V_{\text{SENSE}} = 100 \text{ mV}$  and referred to the input (RTI) of the current-shunt monitor, as shown in Equation 3

$$V_{\text{OSRTI}} (\text{Referred - To - Input}) = \left( \frac{V_{\text{OUT1}}}{G} \right) - 100 \text{ mV}$$

In the Typical Characteristics, the *Output Error vs Common-Mode Voltage* curve shows the highest accuracy for this region of operation. In this plot,  $V_{\text{S}} = 12 \text{ V}$ ; for  $V_{\text{CM}} \geq 12 \text{ V}$ , the output error is at its minimum. This case is also used to create the  $V_{\text{SENSE}} \geq 20\text{-mV}$  output specifications in *Electrical Characteristics: Current-Shunt Monitor* through *Electrical Characteristics: General*.

## Device Functional Modes (continued)

### 8.4.1.2 Normal Case 2: $V_{SENSE} \geq 20\text{ mV}$ , $V_{CM} < V_S$

This region of operation has slightly less accuracy than Normal Case 1 as a result of the common-mode operating area in which the part functions, as seen in the *Output Error vs Common-mode Voltage* curve. As noted, for this graph  $V_S = 12\text{ V}$ ; for  $V_{CM} < 12\text{ V}$ , the Output Error increases as  $V_{CM}$  becomes less than  $12\text{ V}$ , with a typical maximum error of 0.005% at the most negative  $V_{CM} = -16\text{ V}$ .

Low  $V_{SENSE}$  Case 1:  $V_{SENSE} < 20\text{ mV}$ ,  $-16\text{ V} \leq V_{CM} < 0$ ; and

Low  $V_{SENSE}$  Case 3:  $V_{SENSE} < 20\text{ mV}$ ,  $V_S < V_{CM} \leq 80\text{ V}$

Although the INA206 family of devices are not designed for accurate operation in either of these regions, some applications are exposed to these conditions; for example, when monitoring power supplies that are switched on and off while  $V_S$  is still applied to the INA206, INA207, or INA208. It is important to know what the behavior of the devices will be in these regions.

As  $V_{SENSE}$  approaches 0 mV, in these  $V_{CM}$  regions, the device output accuracy degrades. A larger-than-normal offset can appear at the current-shunt monitor output with a typical maximum value of  $V_{OUT} = 300\text{ mV}$  for  $V_{SENSE} = 0\text{ mV}$ . As  $V_{SENSE}$  approaches 20 mV,  $V_{OUT}$  Returns to the expected output value with accuracy as specified in [Electrical Characteristics: Current-Shunt Monitor](#) through [Electrical Characteristics: General](#). Figure 38 illustrates this effect using the INA208 (Gain = 100).

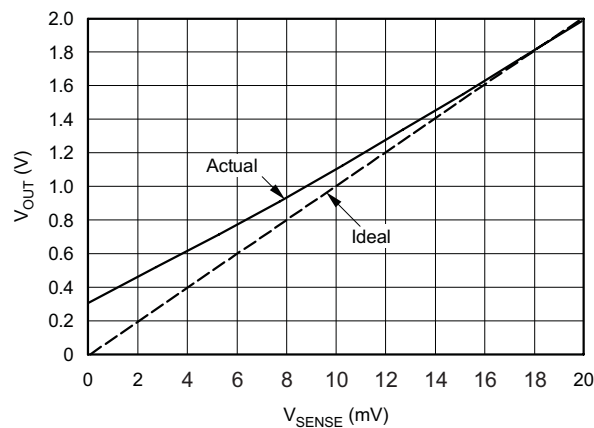
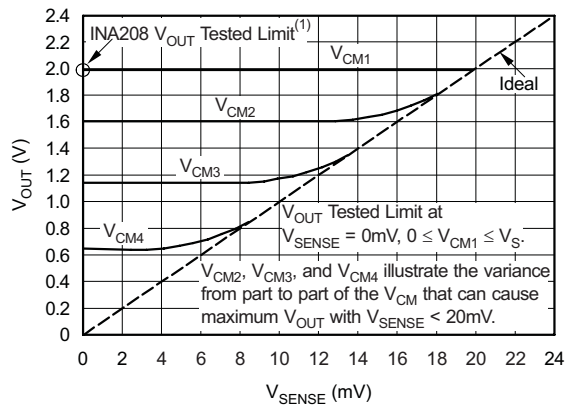

**Figure 38. Example for Low  $V_{SENSE}$  Cases 1 and 3 (INA208, Gain = 100)**

### 8.4.1.3 Low $V_{SENSE}$ Case 2: $V_{SENSE} < 20\text{ mV}$ , $0\text{ V} \leq V_{CM} \leq V_S$

This region of operation is the least accurate for the INA206 family. To achieve the wide input common-mode voltage range, these devices use two op amp front ends in parallel. One op amp front end operates in the positive input common-mode voltage range, and the other in the negative input region. For this case, neither of these two internal amplifiers dominates and overall loop gain is very low. Within this region,  $V_{OUT}$  approaches voltages close to linear operation levels for Normal Case 2. This deviation from linear operation becomes greatest the closer  $V_{SENSE}$  approaches 0 V. Within this region, as  $V_{SENSE}$  approaches 20 mV, device operation is closer to that described by Normal Case 2. Figure 39 illustrates this behavior for the INA208. The  $V_{OUT}$  maximum peak for this case is tested by maintaining a constant  $V_S$ , setting  $V_{SENSE} = 0\text{ mV}$  and sweeping  $V_{CM}$  from 0 V to  $V_S$ . The exact  $V_{CM}$  at which  $V_{OUT}$  peaks during this test varies from part to part, but the  $V_{OUT}$  maximum peak is tested to be less than the specified  $V_{OUT}$  Tested Limit.

Device Functional Modes (continued)



NOTE: (1) INA206  $V_{OUT}$  Tested Limit = 0.4V. INA207  $V_{OUT}$  Tested Limit = 1V.

Figure 39. Example for Low  $V_{SENSE}$  Case 2 (INA208, Gain = 100)

## 9 Application and Implementation

### NOTE

Information in the following applications sections is not part of the TI component specification, and TI does not warrant its accuracy or completeness. TI's customers are responsible for determining suitability of components for their purposes. Customers should validate and test their design implementation to confirm system functionality.

### 9.1 Application Information

#### 9.1.1 Basic Connection

Figure 40 shows the basic connection of the INA206, INA207, and INA208. The input pins, VIN+ and VIN–, should be connected as closely as possible to the shunt resistor to minimize any resistance in series with the shunt resistance.

Power-supply bypass capacitors are required for stability. Applications with noisy or high impedance power supplies may require additional decoupling capacitors to reject power-supply noise. Connect bypass capacitors close to the device pins.

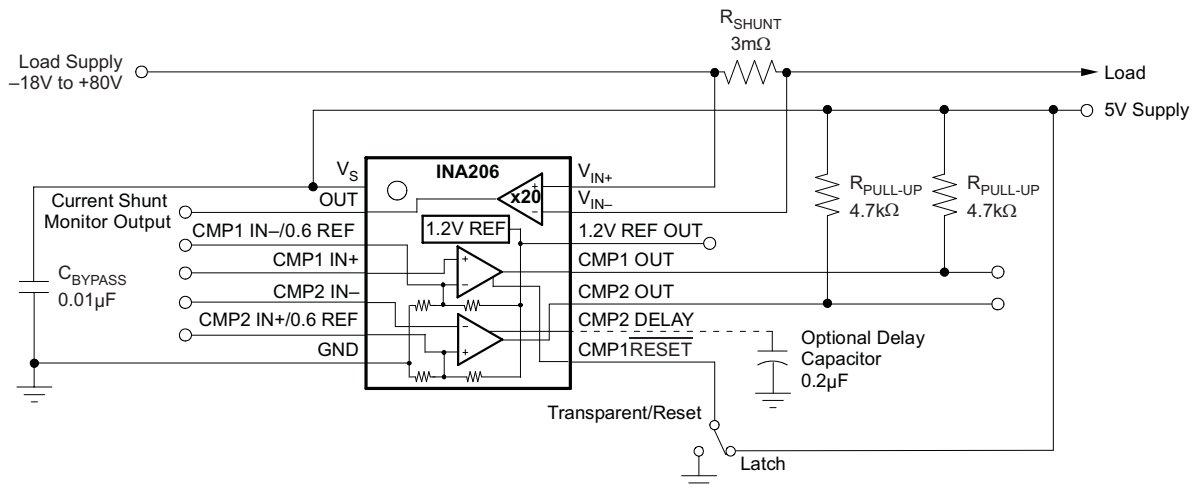

**Figure 40. INA20x Basic Connection**

### 9.2 Typical Application

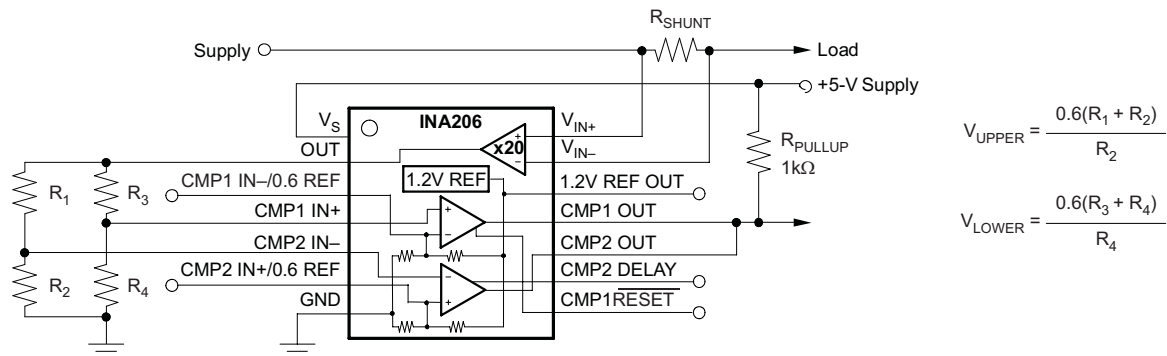

**Figure 41. Using the INA206, INA207, and INA208 as Window Comparators**

## Typical Application (continued)

### 9.2.1 Design Requirements

The device measures current through a resistive shunt with current flowing in one direction. The outputs of the two comparators are in logic AND connection thus enabling the window comparison. When the INA output voltage is within the upper and lower limits, the composite comparator output is high. When the INA output voltage is above the upper limit or below the lower limit, the composite comparator output remains low.

### 9.2.2 Detailed Design Procedure

#### 9.2.2.1 Selecting $R_S$

The value chosen for the shunt resistor,  $R_S$ , depends on the application and is a compromise between small-signal accuracy and maximum permissible voltage loss in the measurement line. High values of  $R_S$  provide better accuracy at lower currents by minimizing the effects of offset, while low values of  $R_S$  minimize voltage loss in the supply line. For most applications, best performance is attained with an  $R_S$  value that provides a full-scale shunt voltage range of 50 mV to 100 mV. Maximum input voltage for accurate measurements is  $(V_S - 0.2) / \text{Gain}$ .

#### 9.2.2.2 Transient Protection

The –16-V to 80-V common-mode range of the INA206, INA207, and INA208 is ideal for withstanding automotive fault conditions ranging from 12-V battery reversal up to 80-V transients, since no additional protective components are needed up to those levels. In the event that the INA206, INA207, and INA208 are exposed to transients on the inputs in excess of their ratings, then external transient absorption with semiconductor transient absorbers (*Zeners* or *Transzorbs*) will be necessary. Use of MOVs or VDRs is not recommended except when they are used in addition to a semiconductor transient absorber. Select the transient absorber such that it will never allow the INA206, INA207, and INA208 to be exposed to transients greater than 80 V (that is, allow for transient absorber tolerance, as well as additional voltage due to transient absorber dynamic impedance). Despite the use of internal Zener-type ESD protection, the INA206, INA207, and INA208 do not lend themselves to using external resistors in series with the inputs since the internal gain resistors can vary up to  $\pm 30\%$  but are closely matched. (If gain accuracy is not important, then resistors can be added in series with the INA206, INA207, and INA208 inputs with two equal resistors on each input.)

#### 9.2.2.3 Input Filtering

An obvious and straightforward location for filtering is at the output of the INA206, INA207, and INA208 series; however, this location negates the advantage of the low output impedance of the internal buffer. The only other option for filtering is at the input pins of the INA206, INA207, and INA208, which is complicated by the internal 5 k $\Omega$  + 30% input impedance; this is shown in [Figure 42](#). Using the lowest possible resistor values minimizes both the initial shift in gain and effects of tolerance. The effect on initial gain is given by [Equation 4](#).

$$\text{Gain Error\%} = 100 - \left( 100 \times \frac{5 \text{ k}\Omega}{5 \text{ k}\Omega + R_{\text{FILT}}} \right) \quad (4)$$

Total effect on gain error can be calculated by replacing the 5-k $\Omega$  term with 5 k $\Omega$  – 30%, (or 3.5 k $\Omega$ ) or 5 k $\Omega$  + 30%, (or 6.5 k $\Omega$ ). The tolerance extremes of  $R_{\text{FILT}}$  can also be inserted into the equation. If a pair of 100  $\Omega$  1% resistors are used on the inputs, the initial gain error will be 1.96%. Worst-case tolerance conditions will always occur at the lower excursion of the internal 5-k $\Omega$  resistor (3.5 k $\Omega$ ), and the higher excursion of  $R_{\text{FILT}}$ — 2.8% in this case.

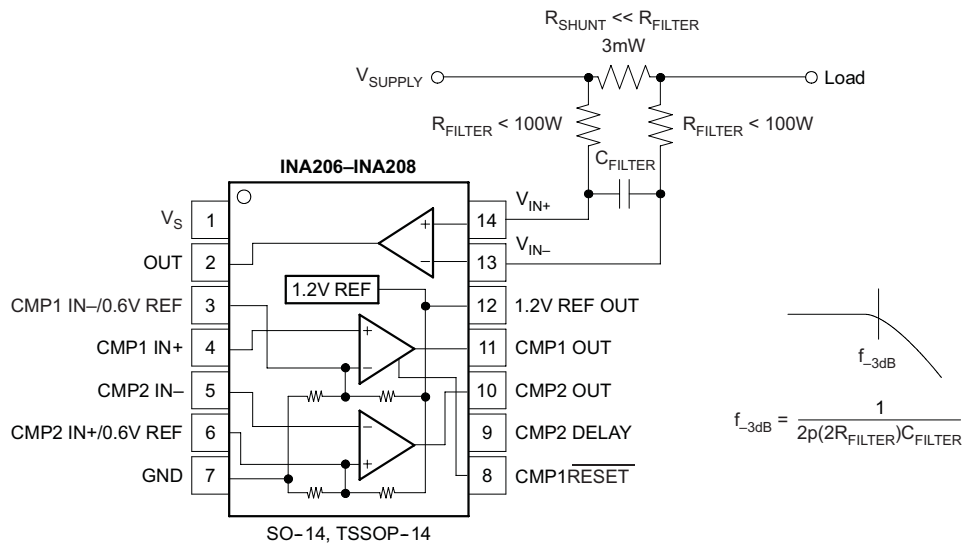
**Typical Application (continued)**

**Figure 42. Input Filter (Gain Error 1.5% to 2.8%)**

Note that the specified accuracy of the INA26, INA207, and INA208 must then be combined in addition to these tolerances. While this discussion treated accuracy worst-case conditions by combining the extremes of the resistor values, it is appropriate to use geometric mean or root sum square calculations to total the effects of accuracy variations.

## Typical Application (continued)

### 9.2.3 Application Curve

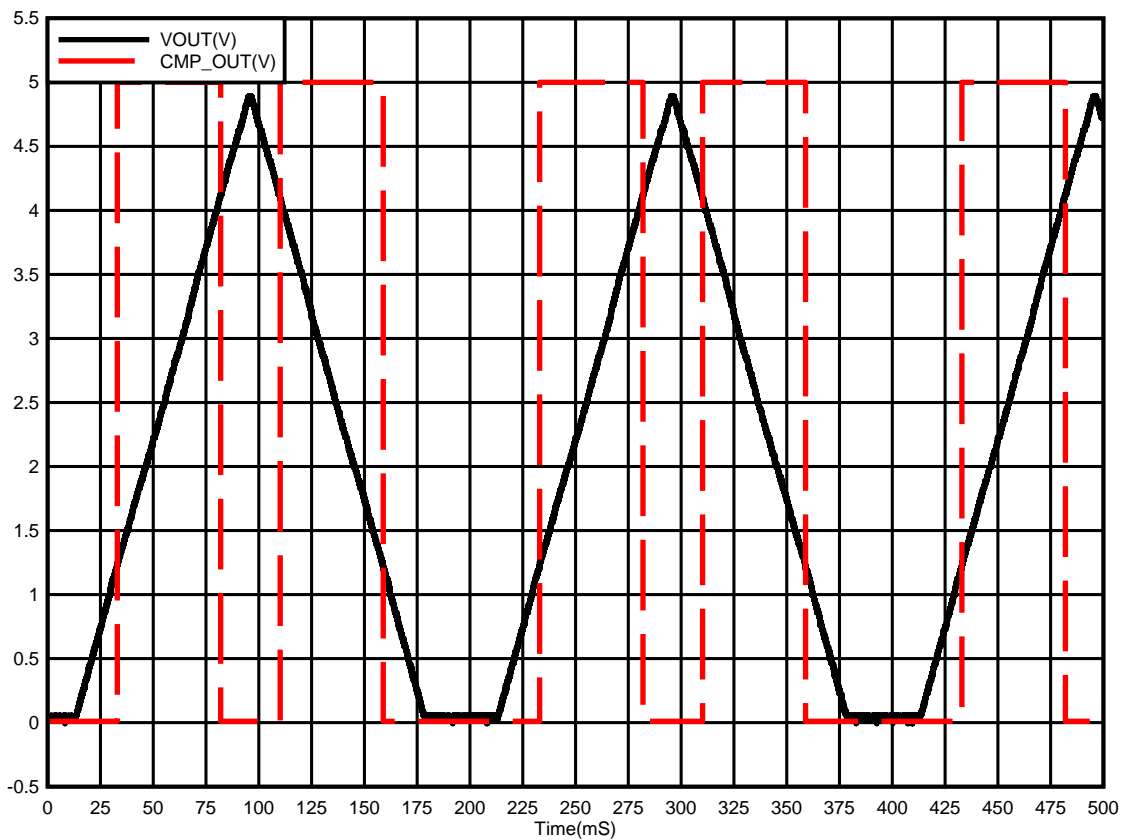

Figure 43. Window Comparator Circuit Response

## 10 Power Supply Recommendations

The input circuitry of the INA206, INA207, and INA208 can accurately measure beyond the power-supply voltage,  $V_s$ . For example, the  $V_s$  power supply can be 5 V, whereas the load power-supply voltage is up to 80 V. The output voltage range of the OUT terminal, however, is limited by the voltages on the power-supply pin.

## 11 Layout

### 11.1 Layout Guidelines

- Connect the input pins to the sensing resistor using a Kelvin or 4-wire connection. This connection technique ensures that only the current-sensing resistor impedance is detected between the input pins. Poor routing of the current-sensing resistor commonly results in additional resistance present between the input pins. Given the very low ohmic value of the current resistor, any additional high-current carrying impedance can cause significant measurement errors.
- The power-supply bypass capacitor must be placed as close as possible to the supply and ground pins. The recommended value of this bypass capacitor is 0.1  $\mu\text{F}$ . Additional decoupling capacitance can be added to compensate for noisy or high-impedance power supplies.

### 11.2 Layout Example

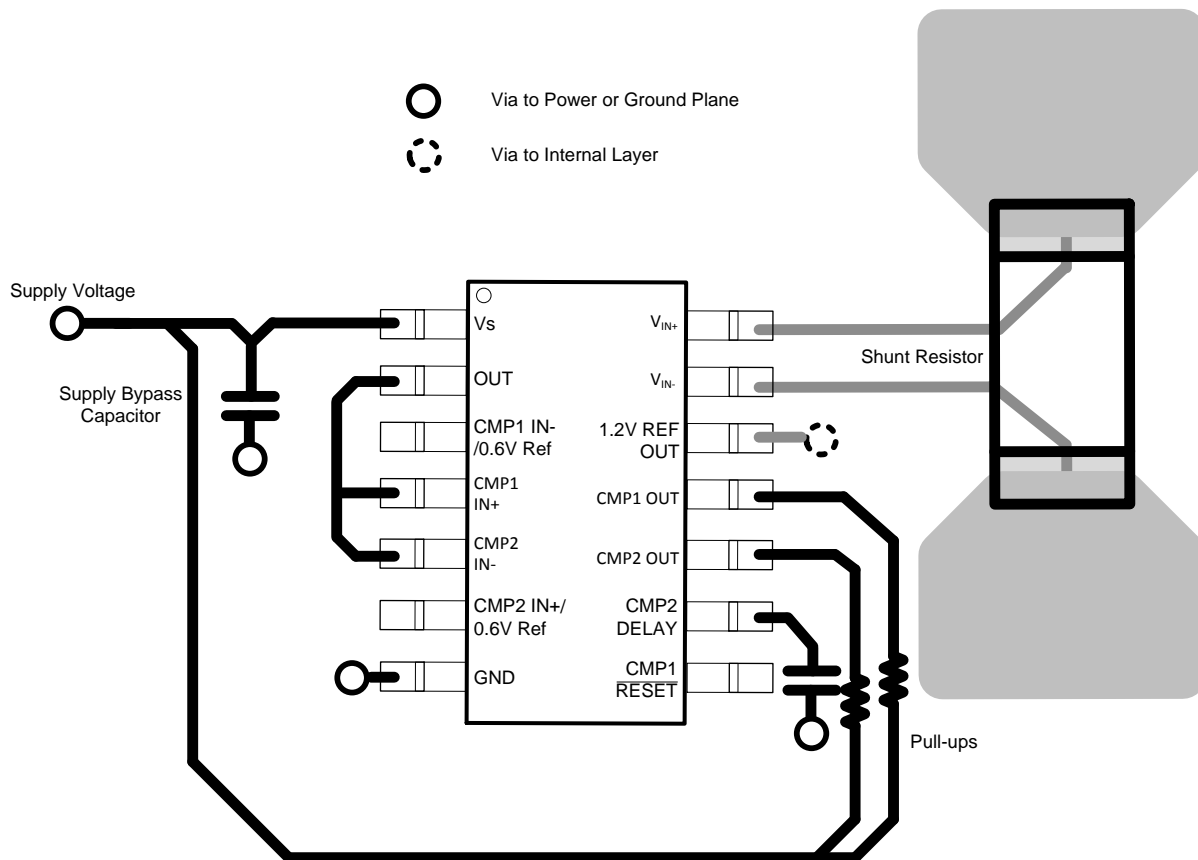

**Figure 44. Layout Recommendation**

## 12 Device and Documentation Support

### 12.1 Related Links

The table below lists quick access links. Categories include technical documents, support and community resources, tools and software, and quick access to sample or buy.

**Table 1. Related Links**

PARTS	PRODUCT FOLDER	SAMPLE & BUY	TECHNICAL DOCUMENTS	TOOLS & SOFTWARE	SUPPORT & COMMUNITY
INA206	<a href="#">Click here</a>	<a href="#">Click here</a>	<a href="#">Click here</a>	<a href="#">Click here</a>	<a href="#">Click here</a>
INA207	<a href="#">Click here</a>	<a href="#">Click here</a>	<a href="#">Click here</a>	<a href="#">Click here</a>	<a href="#">Click here</a>
INA208	<a href="#">Click here</a>	<a href="#">Click here</a>	<a href="#">Click here</a>	<a href="#">Click here</a>	<a href="#">Click here</a>

### 12.2 Community Resources

The following links connect to TI community resources. Linked contents are provided "AS IS" by the respective contributors. They do not constitute TI specifications and do not necessarily reflect TI's views; see TI's [Terms of Use](#).

**TI E2E™ Online Community** *TI's Engineer-to-Engineer (E2E) Community*. Created to foster collaboration among engineers. At [e2e.ti.com](http://e2e.ti.com), you can ask questions, share knowledge, explore ideas and help solve problems with fellow engineers.

**Design Support** *TI's Design Support* Quickly find helpful E2E forums along with design support tools and contact information for technical support.

### 12.3 Trademarks

E2E is a trademark of Texas Instruments.

All other trademarks are the property of their respective owners.

### 12.4 Electrostatic Discharge Caution



These devices have limited built-in ESD protection. The leads should be shorted together or the device placed in conductive foam during storage or handling to prevent electrostatic damage to the MOS gates.

### 12.5 Glossary

[SLYZ022](#) — *TI Glossary*.

This glossary lists and explains terms, acronyms, and definitions.

## 13 Mechanical, Packaging, and Orderable Information

The following pages include mechanical, packaging, and orderable information. This information is the most current data available for the designated devices. This data is subject to change without notice and revision of this document. For browser-based versions of this data sheet, refer to the left-hand navigation.

**PACKAGING INFORMATION**

Orderable Device	Status (1)	Package Type	Package Drawing	Pins	Package Qty	Eco Plan (2)	Lead/Ball Finish (6)	MSL Peak Temp (3)	Op Temp (°C)	Device Marking (4/5)	Samples
INA206AID	ACTIVE	SOIC	D	14	50	Green (RoHS & no Sb/Br)	CU NIPDAU	Level-2-260C-1 YEAR	-40 to 125	INA206A	<a href="#">Samples</a>
INA206AIDGSR	ACTIVE	VSSOP	DGS	10	2500	Green (RoHS & no Sb/Br)	CU NIPDAUAG	Level-2-260C-1 YEAR	-40 to 125	BQQ	<a href="#">Samples</a>
INA206AIDGST	ACTIVE	VSSOP	DGS	10	250	Green (RoHS & no Sb/Br)	CU NIPDAUAG	Level-2-260C-1 YEAR	-40 to 125	BQQ	<a href="#">Samples</a>
INA206AIDR	ACTIVE	SOIC	D	14	2500	Green (RoHS & no Sb/Br)	CU NIPDAU	Level-2-260C-1 YEAR	-40 to 125	INA206A	<a href="#">Samples</a>
INA206AIPW	ACTIVE	TSSOP	PW	14	90	Green (RoHS & no Sb/Br)	CU NIPDAU	Level-2-260C-1 YEAR	-40 to 125	INA206A	<a href="#">Samples</a>
INA206AIPWR	ACTIVE	TSSOP	PW	14	2000	Green (RoHS & no Sb/Br)	CU NIPDAU	Level-2-260C-1 YEAR	-40 to 125	INA206A	<a href="#">Samples</a>
INA207AID	ACTIVE	SOIC	D	14	50	Green (RoHS & no Sb/Br)	CU NIPDAU	Level-2-260C-1 YEAR	-40 to 125	INA207A	<a href="#">Samples</a>
INA207AIDGSR	ACTIVE	VSSOP	DGS	10	2500	Green (RoHS & no Sb/Br)	CU NIPDAUAG	Level-2-260C-1 YEAR	-40 to 125	BQR	<a href="#">Samples</a>
INA207AIDGST	ACTIVE	VSSOP	DGS	10	250	Green (RoHS & no Sb/Br)	CU NIPDAUAG	Level-2-260C-1 YEAR	-40 to 125	BQR	<a href="#">Samples</a>
INA207AIPW	ACTIVE	TSSOP	PW	14	90	Green (RoHS & no Sb/Br)	CU NIPDAU	Level-2-260C-1 YEAR	-40 to 125	INA207A	<a href="#">Samples</a>
INA207AIPWR	ACTIVE	TSSOP	PW	14	2000	Green (RoHS & no Sb/Br)	CU NIPDAU	Level-2-260C-1 YEAR	-40 to 125	INA207A	<a href="#">Samples</a>
INA208AID	ACTIVE	SOIC	D	14	50	Green (RoHS & no Sb/Br)	CU NIPDAU	Level-2-260C-1 YEAR	-40 to 125	INA208A	<a href="#">Samples</a>
INA208AIDGSR	ACTIVE	VSSOP	DGS	10	2500	Green (RoHS & no Sb/Br)	CU NIPDAU   CU NIPDAUAG	Level-2-260C-1 YEAR	-40 to 125	BQS	<a href="#">Samples</a>
INA208AIDGST	ACTIVE	VSSOP	DGS	10	250	Green (RoHS & no Sb/Br)	CU NIPDAU   CU NIPDAUAG	Level-2-260C-1 YEAR	-40 to 125	BQS	<a href="#">Samples</a>
INA208AIDR	ACTIVE	SOIC	D	14	2500	Green (RoHS & no Sb/Br)	CU NIPDAU	Level-2-260C-1 YEAR	-40 to 125	INA208A	<a href="#">Samples</a>
INA208AIPW	ACTIVE	TSSOP	PW	14	90	Green (RoHS & no Sb/Br)	CU NIPDAU	Level-2-260C-1 YEAR	-40 to 125	INA208A	<a href="#">Samples</a>
INA208AIPWR	ACTIVE	TSSOP	PW	14	2000	Green (RoHS & no Sb/Br)	CU NIPDAU	Level-2-260C-1 YEAR	-40 to 125	INA208A	<a href="#">Samples</a>

(1) The marketing status values are defined as follows:

**ACTIVE:** Product device recommended for new designs.

**LIFEBUY:** TI has announced that the device will be discontinued, and a lifetime-buy period is in effect.

**NRND:** Not recommended for new designs. Device is in production to support existing customers, but TI does not recommend using this part in a new design.

**PREVIEW:** Device has been announced but is not in production. Samples may or may not be available.

**OBSOLETE:** TI has discontinued the production of the device.

(2) **RoHS:** TI defines "RoHS" to mean semiconductor products that are compliant with the current EU RoHS requirements for all 10 RoHS substances, including the requirement that RoHS substance do not exceed 0.1% by weight in homogeneous materials. Where designed to be soldered at high temperatures, "RoHS" products are suitable for use in specified lead-free processes. TI may reference these types of products as "Pb-Free".

**RoHS Exempt:** TI defines "RoHS Exempt" to mean products that contain lead but are compliant with EU RoHS pursuant to a specific EU RoHS exemption.

**Green:** TI defines "Green" to mean the content of Chlorine (Cl) and Bromine (Br) based flame retardants meet JS709B low halogen requirements of  $\leq 1000$ ppm threshold. Antimony trioxide based flame retardants must also meet the  $\leq 1000$ ppm threshold requirement.

(3) MSL, Peak Temp. - The Moisture Sensitivity Level rating according to the JEDEC industry standard classifications, and peak solder temperature.

(4) There may be additional marking, which relates to the logo, the lot trace code information, or the environmental category on the device.

(5) Multiple Device Markings will be inside parentheses. Only one Device Marking contained in parentheses and separated by a "~" will appear on a device. If a line is indented then it is a continuation of the previous line and the two combined represent the entire Device Marking for that device.

(6) Lead/Ball Finish - Orderable Devices may have multiple material finish options. Finish options are separated by a vertical ruled line. Lead/Ball Finish values may wrap to two lines if the finish value exceeds the maximum column width.

**Important Information and Disclaimer:** The information provided on this page represents TI's knowledge and belief as of the date that it is provided. TI bases its knowledge and belief on information provided by third parties, and makes no representation or warranty as to the accuracy of such information. Efforts are underway to better integrate information from third parties. TI has taken and continues to take reasonable steps to provide representative and accurate information but may not have conducted destructive testing or chemical analysis on incoming materials and chemicals. TI and TI suppliers consider certain information to be proprietary, and thus CAS numbers and other limited information may not be available for release.

In no event shall TI's liability arising out of such information exceed the total purchase price of the TI part(s) at issue in this document sold by TI to Customer on an annual basis.

## TAPE AND REEL INFORMATION



### QUADRANT ASSIGNMENTS FOR PIN 1 ORIENTATION IN TAPE



\*All dimensions are nominal

Device	Package Type	Package Drawing	Pins	SPQ	Reel Diameter (mm)	Reel Width W1 (mm)	A0 (mm)	B0 (mm)	K0 (mm)	P1 (mm)	W (mm)	Pin1 Quadrant
INA206AIDGSR	VSSOP	DGS	10	2500	330.0	12.4	5.3	3.4	1.4	8.0	12.0	Q1
INA206AIDGST	VSSOP	DGS	10	250	330.0	12.4	5.3	3.4	1.4	8.0	12.0	Q1
INA206AIDR	SOIC	D	14	2500	330.0	16.4	6.5	9.0	2.1	8.0	16.0	Q1
INA206AIPWR	TSSOP	PW	14	2000	330.0	12.4	6.9	5.6	1.6	8.0	12.0	Q1
INA207AIDGSR	VSSOP	DGS	10	2500	330.0	12.4	5.3	3.4	1.4	8.0	12.0	Q1
INA207AIDGST	VSSOP	DGS	10	250	180.0	12.4	5.3	3.4	1.4	8.0	12.0	Q1
INA207AIPWR	TSSOP	PW	14	2000	330.0	12.4	6.9	5.6	1.6	8.0	12.0	Q1
INA208AIDGSR	VSSOP	DGS	10	2500	330.0	12.4	5.3	3.4	1.4	8.0	12.0	Q1
INA208AIDGST	VSSOP	DGS	10	250	180.0	12.4	5.3	3.4	1.4	8.0	12.0	Q1
INA208AIDR	SOIC	D	14	2500	330.0	16.4	6.5	9.0	2.1	8.0	16.0	Q1
INA208AIPWR	TSSOP	PW	14	2000	330.0	12.4	6.9	5.6	1.6	8.0	12.0	Q1

**TAPE AND REEL BOX DIMENSIONS**

\*All dimensions are nominal

Device	Package Type	Package Drawing	Pins	SPQ	Length (mm)	Width (mm)	Height (mm)
INA206AIDGSR	VSSOP	DGS	10	2500	366.0	364.0	50.0
INA206AIDGST	VSSOP	DGS	10	250	366.0	364.0	50.0
INA206AIDR	SOIC	D	14	2500	367.0	367.0	38.0
INA206AIPWR	TSSOP	PW	14	2000	367.0	367.0	35.0
INA207AIDGSR	VSSOP	DGS	10	2500	367.0	367.0	35.0
INA207AIDGST	VSSOP	DGS	10	250	210.0	185.0	35.0
INA207AIPWR	TSSOP	PW	14	2000	367.0	367.0	35.0
INA208AIDGSR	VSSOP	DGS	10	2500	367.0	367.0	35.0
INA208AIDGST	VSSOP	DGS	10	250	210.0	185.0	35.0
INA208AIDR	SOIC	D	14	2500	367.0	367.0	38.0
INA208AIPWR	TSSOP	PW	14	2000	367.0	367.0	35.0

# DGS0010A



# PACKAGE OUTLINE

## VSSOP - 1.1 mm max height

SMALL OUTLINE PACKAGE



4221984/A 05/2015

### NOTES:

1. All linear dimensions are in millimeters. Any dimensions in parenthesis are for reference only. Dimensioning and tolerancing per ASME Y14.5M.
2. This drawing is subject to change without notice.
3. This dimension does not include mold flash, protrusions, or gate burrs. Mold flash, protrusions, or gate burrs shall not exceed 0.15 mm per side.
4. This dimension does not include interlead flash. Interlead flash shall not exceed 0.25 mm per side.
5. Reference JEDEC registration MO-187, variation BA.

# EXAMPLE BOARD LAYOUT

DGS0010A

VSSOP - 1.1 mm max height

SMALL OUTLINE PACKAGE

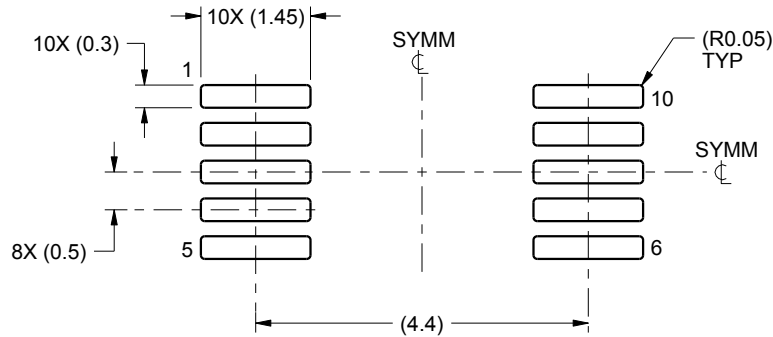

LAND PATTERN EXAMPLE  
SCALE:10X

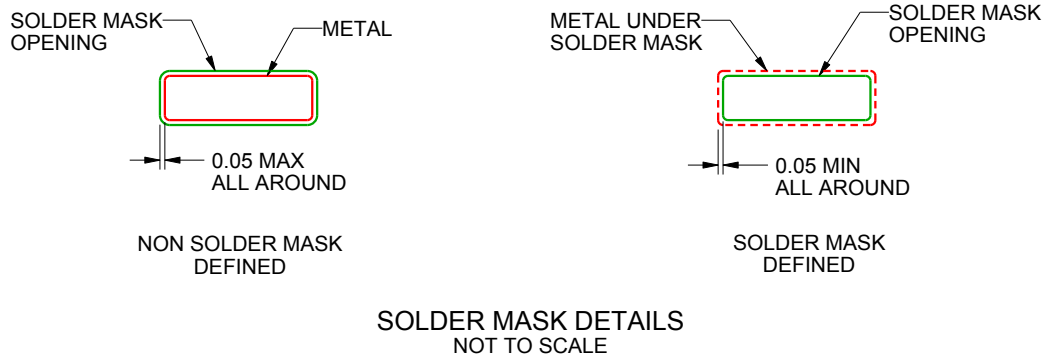

SOLDER MASK DETAILS  
NOT TO SCALE

4221984/A 05/2015

NOTES: (continued)

6. Publication IPC-7351 may have alternate designs.
7. Solder mask tolerances between and around signal pads can vary based on board fabrication site.

# EXAMPLE STENCIL DESIGN

DGS0010A

VSSOP - 1.1 mm max height

SMALL OUTLINE PACKAGE



SOLDER PASTE EXAMPLE  
BASED ON 0.125 mm THICK STENCIL  
SCALE:10X

4221984/A 05/2015

NOTES: (continued)

8. Laser cutting apertures with trapezoidal walls and rounded corners may offer better paste release. IPC-7525 may have alternate design recommendations.
9. Board assembly site may have different recommendations for stencil design.

D (R-PDSO-G14)

PLASTIC SMALL OUTLINE

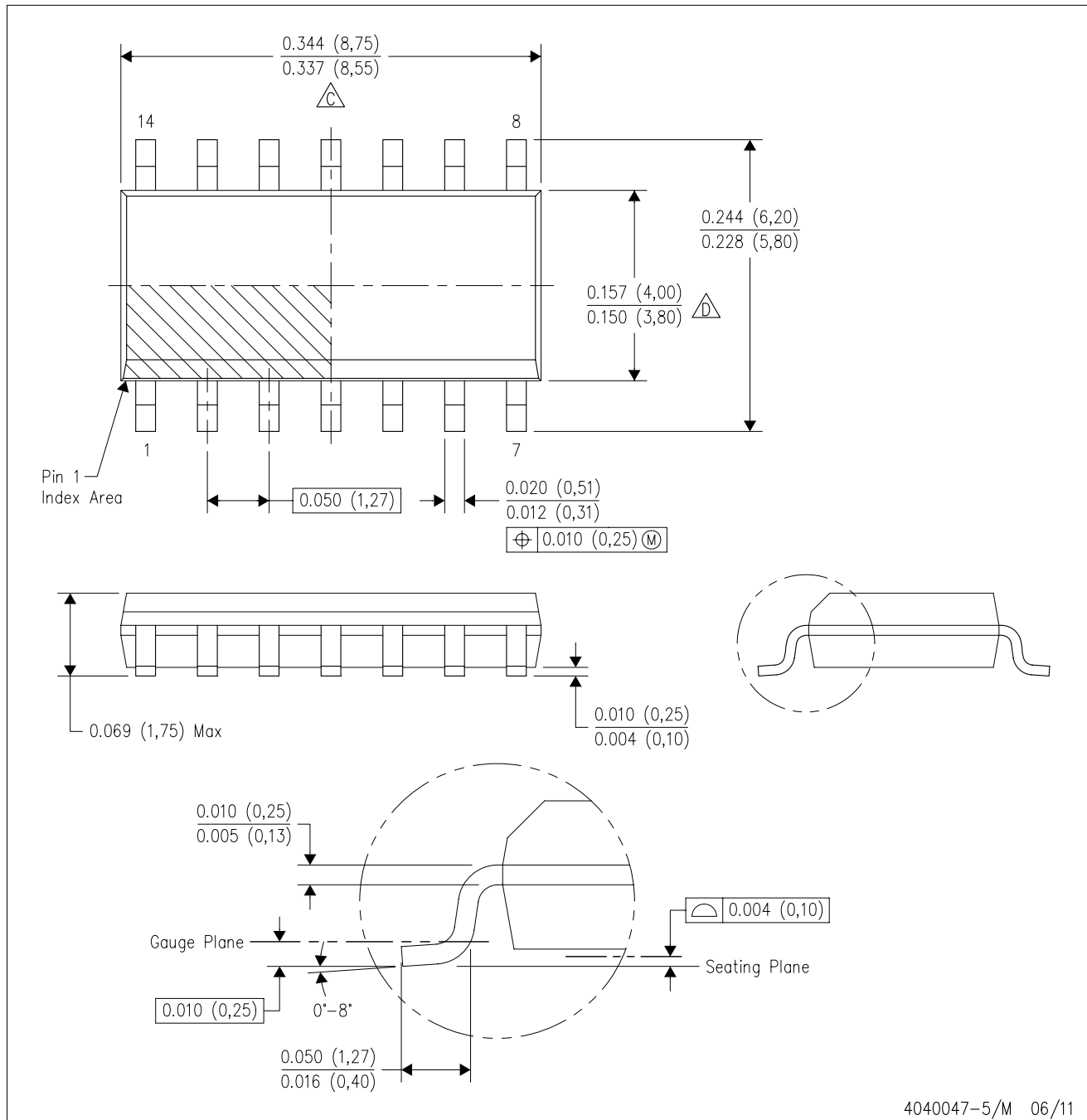

- NOTES:
- A. All linear dimensions are in inches (millimeters).
  - B. This drawing is subject to change without notice.
  - $\triangle C$  Body length does not include mold flash, protrusions, or gate burrs. Mold flash, protrusions, or gate burrs shall not exceed 0.006 (0,15) each side.
  - $\triangle D$  Body width does not include interlead flash. Interlead flash shall not exceed 0.017 (0,43) each side.
  - E. Reference JEDEC MS-012 variation AB.

D (R-PDSO-G14)

PLASTIC SMALL OUTLINE

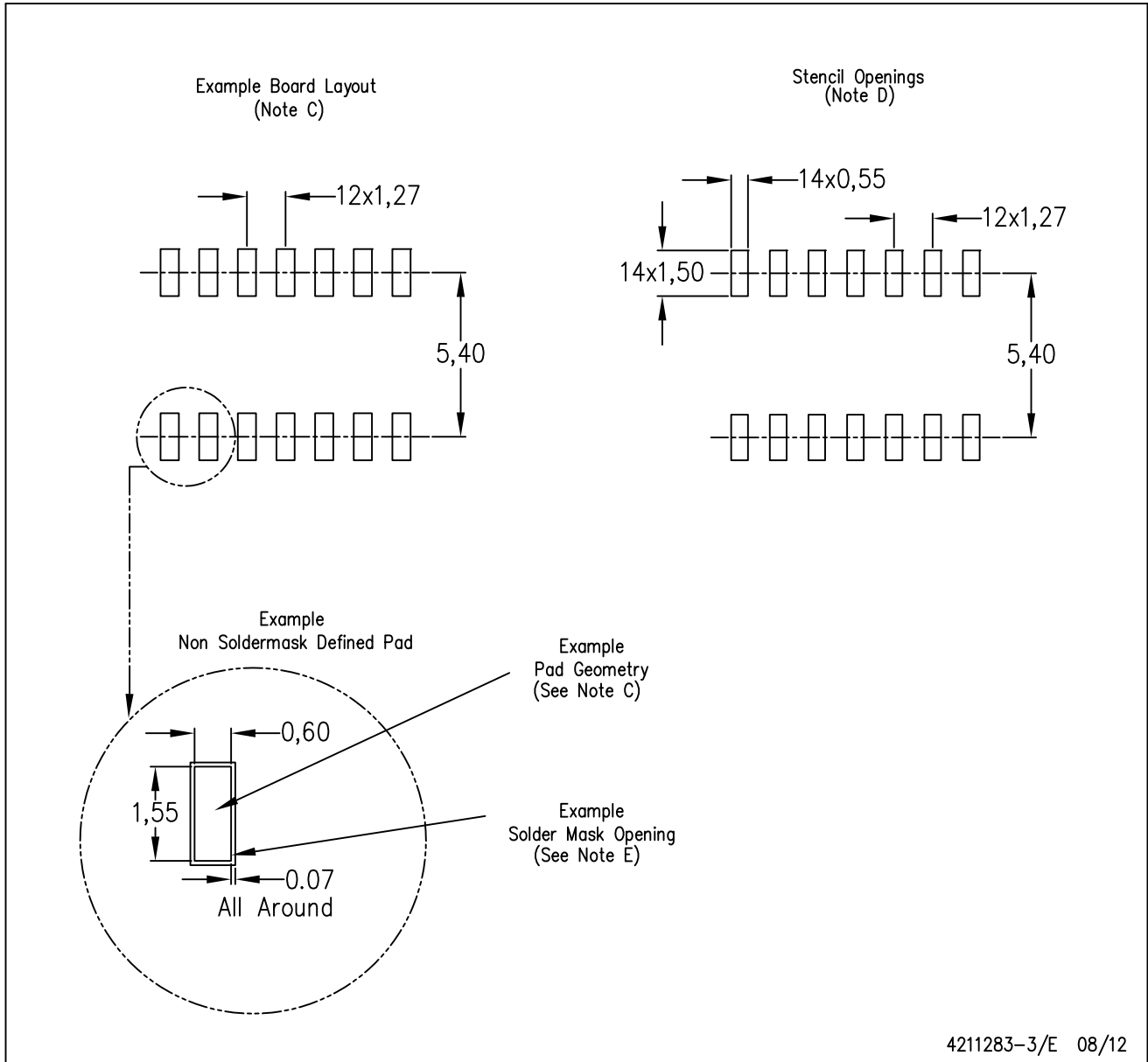

- NOTES:
- All linear dimensions are in millimeters.
  - This drawing is subject to change without notice.
  - Publication IPC-7351 is recommended for alternate designs.
  - Laser cutting apertures with trapezoidal walls and also rounding corners will offer better paste release. Customers should contact their board assembly site for stencil design recommendations. Refer to IPC-7525 for other stencil recommendations.
  - Customers should contact their board fabrication site for solder mask tolerances between and around signal pads.

PW (R-PDSO-G14)

PLASTIC SMALL OUTLINE

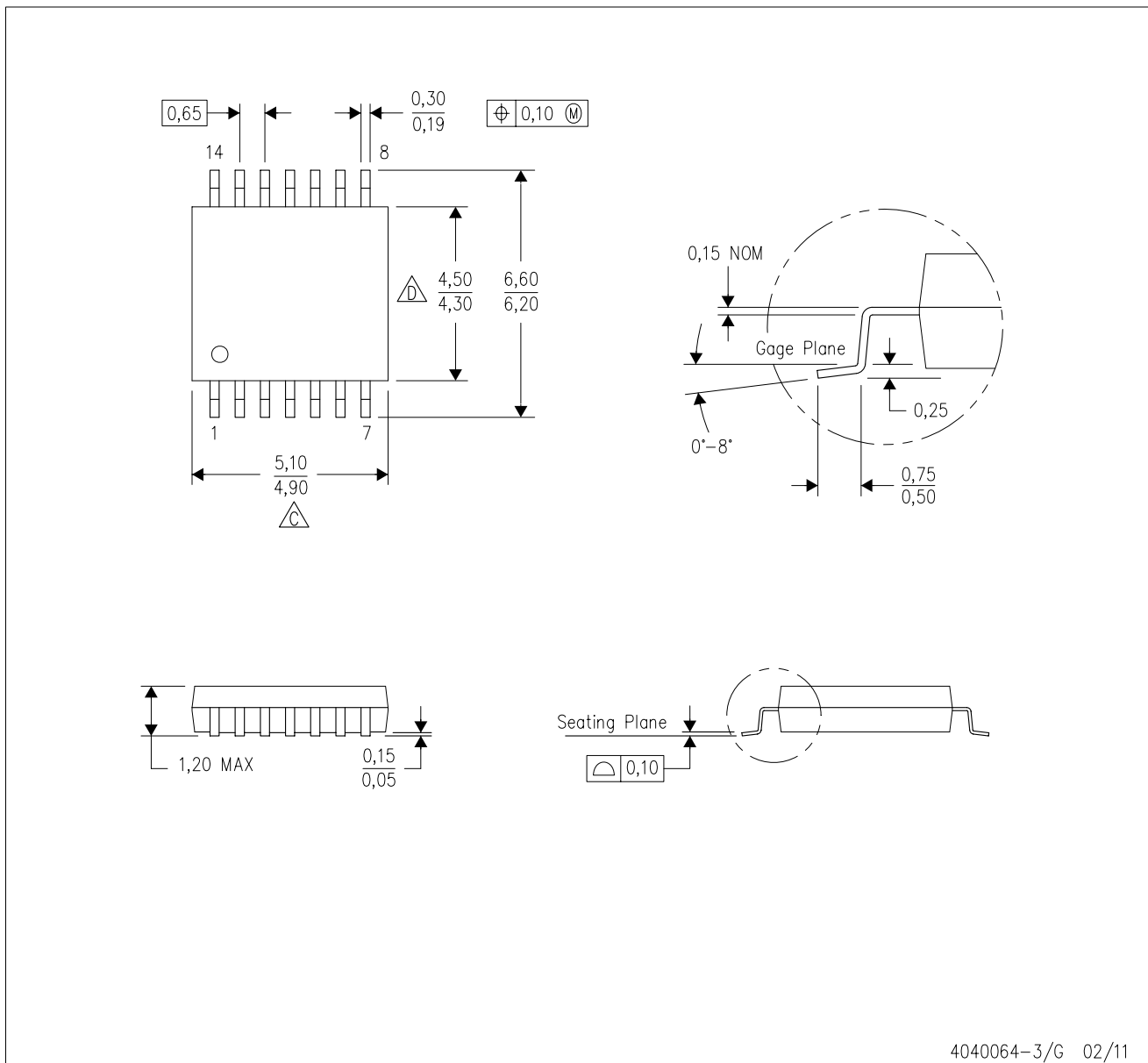

- NOTES:
- A. All linear dimensions are in millimeters. Dimensioning and tolerancing per ASME Y14.5M-1994.
  - B. This drawing is subject to change without notice.
  - C. Body length does not include mold flash, protrusions, or gate burrs. Mold flash, protrusions, or gate burrs shall not exceed 0,15 each side.
  - D. Body width does not include interlead flash. Interlead flash shall not exceed 0,25 each side.
  - E. Falls within JEDEC MO-153

PW (R-PDSO-G14)

PLASTIC SMALL OUTLINE



- NOTES:
- All linear dimensions are in millimeters.
  - This drawing is subject to change without notice.
  - Publication IPC-7351 is recommended for alternate designs.
  - Laser cutting apertures with trapezoidal walls and also rounding corners will offer better paste release. Customers should contact their board assembly site for stencil design recommendations. Refer to IPC-7525 for other stencil recommendations.
  - Customers should contact their board fabrication site for solder mask tolerances between and around signal pads.

## IMPORTANT NOTICE AND DISCLAIMER

TI PROVIDES TECHNICAL AND RELIABILITY DATA (INCLUDING DATASHEETS), DESIGN RESOURCES (INCLUDING REFERENCE DESIGNS), APPLICATION OR OTHER DESIGN ADVICE, WEB TOOLS, SAFETY INFORMATION, AND OTHER RESOURCES "AS IS" AND WITH ALL FAULTS, AND DISCLAIMS ALL WARRANTIES, EXPRESS AND IMPLIED, INCLUDING WITHOUT LIMITATION ANY IMPLIED WARRANTIES OF MERCHANTABILITY, FITNESS FOR A PARTICULAR PURPOSE OR NON-INFRINGEMENT OF THIRD PARTY INTELLECTUAL PROPERTY RIGHTS.

These resources are intended for skilled developers designing with TI products. You are solely responsible for (1) selecting the appropriate TI products for your application, (2) designing, validating and testing your application, and (3) ensuring your application meets applicable standards, and any other safety, security, or other requirements. These resources are subject to change without notice. TI grants you permission to use these resources only for development of an application that uses the TI products described in the resource. Other reproduction and display of these resources is prohibited. No license is granted to any other TI intellectual property right or to any third party intellectual property right. TI disclaims responsibility for, and you will fully indemnify TI and its representatives against, any claims, damages, costs, losses, and liabilities arising out of your use of these resources.

TI's products are provided subject to TI's Terms of Sale ([www.ti.com/legal/termsofsale.html](http://www.ti.com/legal/termsofsale.html)) or other applicable terms available either on [ti.com](http://ti.com) or provided in conjunction with such TI products. TI's provision of these resources does not expand or otherwise alter TI's applicable warranties or warranty disclaimers for TI products.

Mailing Address: Texas Instruments, Post Office Box 655303, Dallas, Texas 75265  
Copyright © 2019, Texas Instruments Incorporated

## Looking for pricing, stock, or lifecycle information?

Click below to explore more details on WIN SOURCE:

 [View INA206AIDGST](#) on WIN SOURCE

 [Texas Instruments](#) Information

## Optimize Your Supply Chain with WIN SOURCE Solutions

-  Global Sourcing Solution
-  Obsolete Management
-  Cost Control Management
-  Shortage Management
-  Alternative Solution
-  Excess Inventory Management