



# THE DATASHEET OF INA230AIRGTR





## High- or Low-Side Measurement, Bidirectional CURRENT/POWER MONITOR with I<sup>2</sup>C™ Interface

Check for Samples: [INA230](#)

### FEATURES

- **Bus Voltage Sensing From 0 V to +28 V**
- **High- or Low-Side Sensing**
- **Current, Voltage, and Power Reporting**
- **High Accuracy:**
  - **0.5% Gain Error (Max)**
  - **50- $\mu$ V Offset (Max)**
- **Configurable Averaging Options**
- **Programmable Alert Threshold**
- **Power Supply Operation: 2.7 V to 5.5 V**
- **Package: 3-mm x 3-mm, 16-Pin QFN**

### APPLICATIONS

- **Smartphones**
- **Tablets**
- **Servers**
- **Computers**
- **Power Management**
- **Battery Chargers**
- **Power Supplies**
- **Test Equipment**

### DESCRIPTION

The INA230 is a current-shunt and power monitor with an I<sup>2</sup>C interface that features 16 programmable addresses. The INA230 monitors both shunt voltage drops and bus supply voltage. Programmable calibration value, conversion times, and averaging, combined with an internal multiplier, enable direct readouts of current in amperes and power in watts.

The INA230 senses current on buses that vary from 0 V to +28 V, with the device powered from a single +2.7 V to +5.5 V supply, drawing 330  $\mu$ A (typical) of supply current. The INA230 is specified over the operating temperature range of  $-40^{\circ}\text{C}$  to  $+125^{\circ}\text{C}$ .

### RELATED PRODUCTS

DESCRIPTION	DEVICE
Current/power monitor with watchdog, peak-hold, and fast comparator functions	<a href="#">INA209</a>
Zero-drift, low-cost, analog current shunt monitor series in small package	<a href="#">INA210</a> , <a href="#">INA211</a> , <a href="#">INA212</a> , <a href="#">INA213</a> , <a href="#">INA214</a>
Zero-drift, bidirectional current power monitor with two-wire interface	<a href="#">INA219</a>
High or low side, bidirectional current/power monitor with two-wire interface	<a href="#">INA220</a>

### HIGH-OR LOW-SIDE SENSING

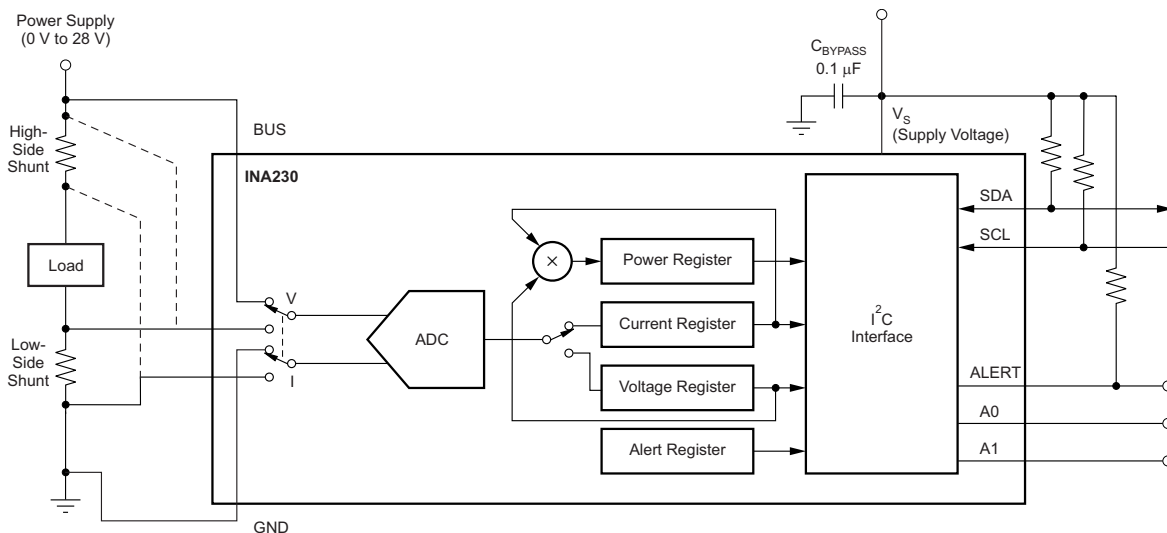

Please be aware that an important notice concerning availability, standard warranty, and use in critical applications of Texas Instruments semiconductor products and disclaimers thereto appears at the end of this data sheet.

I<sup>2</sup>C is a trademark of NXP Semiconductors.

All other trademarks are the property of their respective owners.



This integrated circuit can be damaged by ESD. Texas Instruments recommends that all integrated circuits be handled with appropriate precautions. Failure to observe proper handling and installation procedures can cause damage.

ESD damage can range from subtle performance degradation to complete device failure. Precision integrated circuits may be more susceptible to damage because very small parametric changes could cause the device not to meet its published specifications.

### PACKAGE INFORMATION<sup>(1)</sup>

PRODUCT	PACKAGE-LEAD	PACKAGE DESIGNATOR	PACKAGE MARKING
INA230	QFN-16	RGT	I230

- (1) For the most current package and ordering information see the Package Option Addendum at the end of this document, or see the [INA230 product folder](#) at [www.ti.com](http://www.ti.com).

### ABSOLUTE MAXIMUM RATINGS<sup>(1)</sup>

Over operating free-air temperature range (unless otherwise noted).

		INA230	UNIT
Supply voltage, $V_S$		6	V
Analog inputs, IN+, IN–	Differential ( $V_{IN+} - V_{IN-}$ ) <sup>(2)</sup>	–30 to +30	V
	Common-mode	–0.3 to +30	V
SDA		GND – 0.3 to +6	V
SCL		GND – 0.3 to $V_S + 0.3$	V
Input current into any pin		5	mA
Open-drain digital output current		10	mA
Storage temperature		–65 to +150	°C
Junction temperature		+150	°C
ESD Ratings	Human body model (HBM)	2500	V
	Charged-device model (CDM)	1000	V
	Machine model (MM)	150	V

- (1) Stresses above these ratings may cause permanent damage. Exposure to absolute maximum conditions for extended periods may degrade device reliability. These are stress ratings only, and functional operation of the device at these or any other conditions beyond those specified is not implied.
- (2)  $V_{IN+}$  and  $V_{IN-}$  may have a differential voltage of –30 V to +30 V; however, the voltage at these pins must not exceed the range –0.3 V to +30 V.

**ELECTRICAL CHARACTERISTICS**

At  $T_A = +25^\circ\text{C}$ ,  $V_S = +3.3\text{ V}$ ,  $V_{IN+} = 12\text{ V}$ ,  $V_{SENSE} = (V_{IN+} - V_{IN-}) = 0\text{ mV}$ , and  $V_{BUS} = 12\text{ V}$ , unless otherwise noted.

PARAMETER	CONDITIONS	INA230			UNIT
		MIN	TYP	MAX	
<b>SHUNT INPUT</b>					
Shunt voltage input range		-81.92		81.9175	mV
CMR	Common-mode rejection $V_{IN+} = 0\text{ V to }+28\text{ V}$	100	120		dB
$V_{OS}$	Shunt offset voltage, RTI <sup>(1)</sup>		$\pm 10$	$\pm 50$	$\mu\text{V}$
	$T_A = -40^\circ\text{C to }+125^\circ\text{C}$		0.1	0.5	$\mu\text{V}/^\circ\text{C}$
PSRR	vs power supply $V_S = +2.7\text{ V to }+5.5\text{ V}$		10		$\mu\text{V/V}$
<b>BUS INPUT</b>					
Bus voltage input range <sup>(2)</sup>		0		28	V
$V_{OS}$	Bus offset voltage, RTI <sup>(1)</sup>		$\pm 5$	$\pm 30$	mV
	$T_A = -40^\circ\text{C to }+125^\circ\text{C}$		10	40	$\mu\text{V}/^\circ\text{C}$
PSRR	vs power supply		2		mV/V
	BUS pin input impedance		830		k $\Omega$
<b>INPUT</b>					
$I_{IN+}, I_{IN-}$	Input bias current		10		$\mu\text{A}$
	Input leakage <sup>(3)</sup> $(V_{IN+}) + (V_{IN-})$ , Power-Down mode		0.1	0.5	$\mu\text{A}$
<b>DC ACCURACY</b>					
ADC native resolution			16		Bits
1 LSB step size	Shunt voltage		2.5		$\mu\text{V}$
	Bus voltage		1.25		mV
Shunt voltage gain error			0.2	0.5	%
	$T_A = -40^\circ\text{C to }+125^\circ\text{C}$		10	50	ppm/ $^\circ\text{C}$
Bus voltage gain error			0.2	0.5	%
	$T_A = -40^\circ\text{C to }+125^\circ\text{C}$		10	50	ppm/ $^\circ\text{C}$
Differential nonlinearity			$\pm 0.1$		LSB
ADC conversion time	CT bit = 000		140	154	$\mu\text{s}$
	CT bit = 001		204	224	$\mu\text{s}$
	CT bit = 010		332	365	$\mu\text{s}$
	CT bit = 011		588	646	$\mu\text{s}$
	CT bit = 100		1.1	1.21	ms
	CT bit = 101		2.116	2.328	ms
	CT bit = 110		4.156	4.572	ms
	CT bit = 111		8.244	9.068	ms
<b>SMBus</b>					
SMBus timeout <sup>(4)</sup>			28	35	ms
<b>DIGITAL INPUT/OUTPUT</b>					
Input capacitance			3		pF
Leakage input current	$0 \leq V_{IN} \leq V_S$		0.1	1	$\mu\text{A}$
$V_{IH}$	High-level input voltage		$0.7(V_S)$	6	V
$V_{IL}$	Low-level input voltage		-0.5	$0.3(V_S)$	V
$V_{OL}$	Low-level output voltage (SDA, ALERT)	$I_{OL} = 3\text{ mA}$	0	0.4	V
	Hysteresis		500		mV

(1) RTI = Referred-to-input.

(2) Although the input range is 28 V, the full-scale range of the ADC scaling is 40.96 V. Do not apply more than 28 V. See the [Basic ADC Functions](#) section for more details

(3) Input leakage is positive (current flowing into the pin) for the conditions shown at the top of this table. Negative leakage currents can occur under different input conditions.

(4) SMBus timeout in the INA230 resets the interface any time SCL is low for more than 28 ms.

## ELECTRICAL CHARACTERISTICS (continued)

At  $T_A = +25^\circ\text{C}$ ,  $V_S = +3.3\text{ V}$ ,  $V_{IN+} = 12\text{ V}$ ,  $V_{SENSE} = (V_{IN+} - V_{IN-}) = 0\text{ mV}$ , and  $V_{BUS} = 12\text{ V}$ , unless otherwise noted.

PARAMETER	CONDITIONS	INA230			UNIT
		MIN	TYP	MAX	
<b>POWER SUPPLY</b>					
Operating supply range		+2.7		+5.5	V
Quiescent current			330	420	$\mu\text{A}$
	Power-Down mode		0.5	2	$\mu\text{A}$
Power-on reset threshold			2		V
<b>TEMPERATURE</b>					
Specified range		-40		+125	$^\circ\text{C}$

## THERMAL INFORMATION

THERMAL METRIC <sup>(1)</sup>		INA230	UNITS
		RGT (QFN)	
		10 PINS	
$\theta_{JA}$	Junction-to-ambient thermal resistance	46.1	$^\circ\text{C/W}$
$\theta_{JCTop}$	Junction-to-case (top) thermal resistance	58.4	
$\theta_{JB}$	Junction-to-board thermal resistance	19.1	
$\psi_{JT}$	Junction-to-top characterization parameter	1.3	
$\psi_{JB}$	Junction-to-board characterization parameter	19.1	
$\theta_{JCbott}$	Junction-to-case (bottom) thermal resistance	4.7	

(1) For more information about traditional and new thermal metrics, see the *IC Package Thermal Metrics* application report, [SPRA953](#).

## PIN CONFIGURATIONS

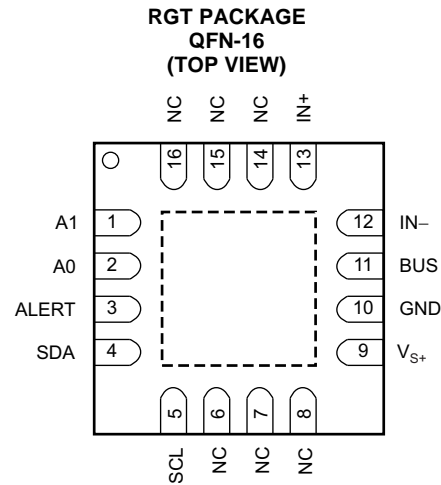

## PIN DESCRIPTIONS

PIN		ANALOG/DIGITAL INPUT/OUTPUT	DESCRIPTION
NAME	NO.		
A0	2	Digital input	Address pin. Connect to GND, SCL, SDA, or $V_S$ . <a href="#">Table 7</a> shows pin settings and corresponding addresses.
A1	1	Digital input	Address pin. Connect to GND, SCL, SDA, or $V_S$ . <a href="#">Table 7</a> shows pin settings and corresponding addresses.
ALERT	3	Digital output	Multi-functional alert, open-drain output.
GND	10	Analog	Ground
NC	6, 7, 8, 14, 15, 16	—	No internal connection
SCL	5	Digital input	Serial bus clock line, open-drain input.
SDA	4	Digital input/output	Serial bus data line, open-drain input/output.
BUS	11	Analog input	Bus voltage input
IN-	12	Analog input	Negative differential shunt voltage input. Connect to load side of shunt resistor.
IN+	13	Analog input	Positive differential shunt voltage input. Connect to supply side of shunt resistor.
$V_S$	9	Analog	Power supply, 2.7 V to 5.5 V.
Thermal Pad			This pad can be connected to ground or left floating.

### REGISTER BLOCK DIAGRAM

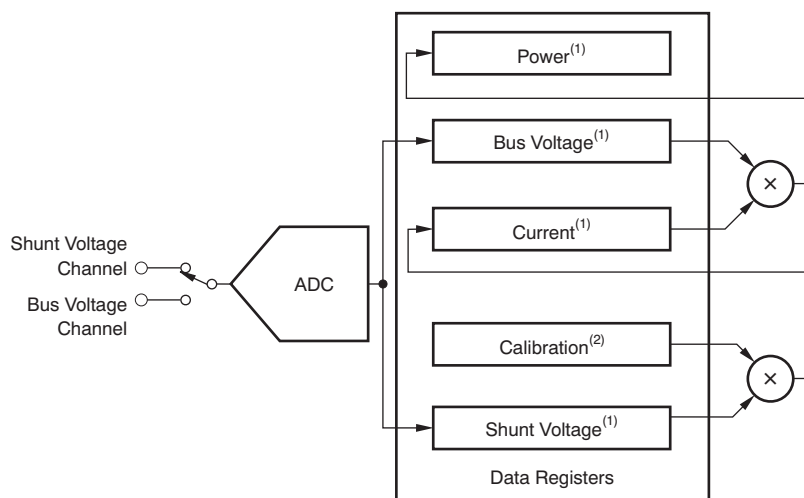

- (1) Read-only
- (2) Read/write

Figure 1. Register Block Diagram

### TYPICAL CHARACTERISTICS

At  $T_A = +25^\circ\text{C}$ ,  $V_S = +3.3\text{ V}$ ,  $V_{IN+} = 12\text{ V}$ ,  $V_{SENSE} = (V_{IN+} - V_{IN-}) = 0\text{ mV}$ , and  $V_{BUS} = 12\text{ V}$ , unless otherwise noted.

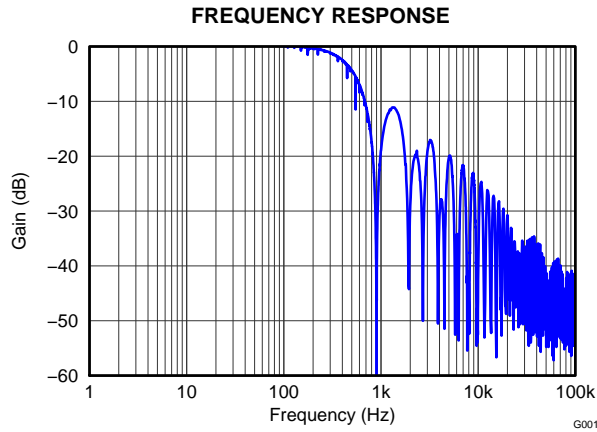

Figure 2.

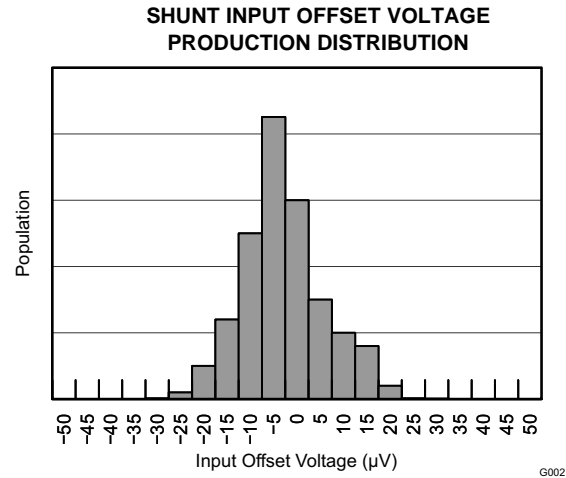

Figure 3.

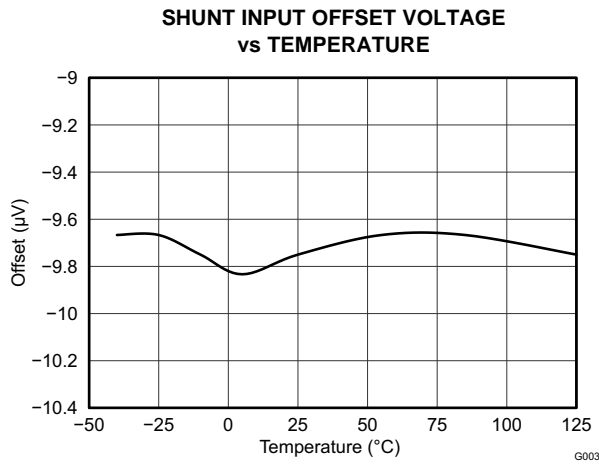

Figure 4.

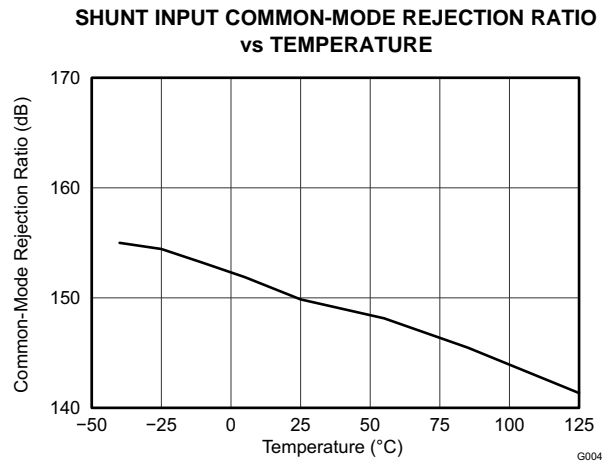

Figure 5.

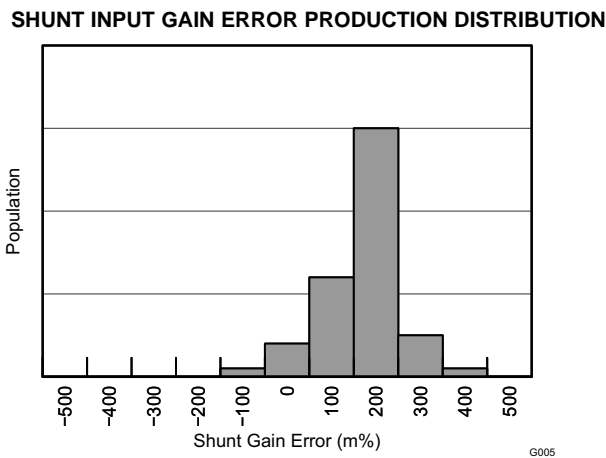

Figure 6.

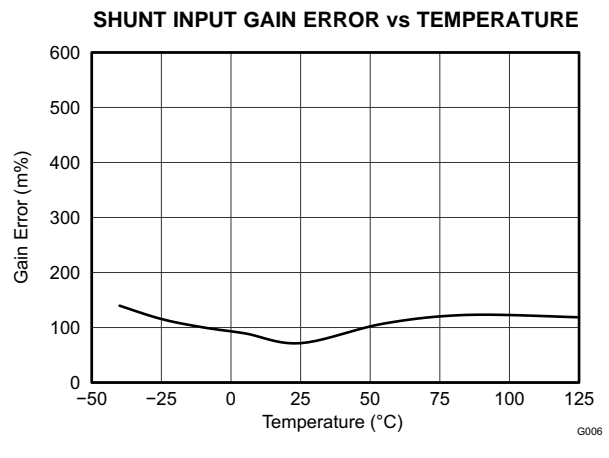

Figure 7.

**TYPICAL CHARACTERISTICS (continued)**

At  $T_A = +25^\circ\text{C}$ ,  $V_S = +3.3\text{ V}$ ,  $V_{IN+} = 12\text{ V}$ ,  $V_{SENSE} = (V_{IN+} - V_{IN-}) = 0\text{ mV}$ , and  $V_{BUS} = 12\text{ V}$ , unless otherwise noted.

**SHUNT INPUT GAIN ERROR vs COMMON-MODE VOLTAGE**

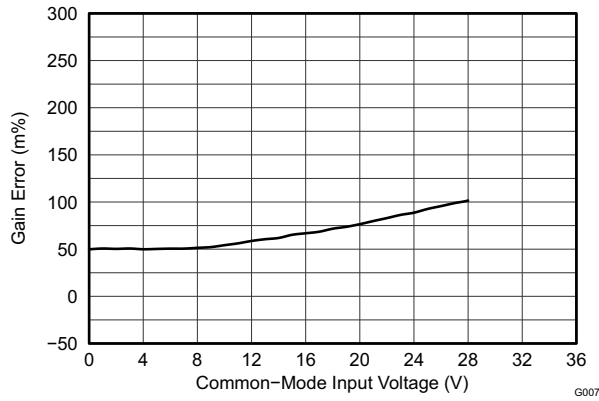

Figure 8.

**BUS INPUT OFFSET VOLTAGE PRODUCTION DISTRIBUTION**

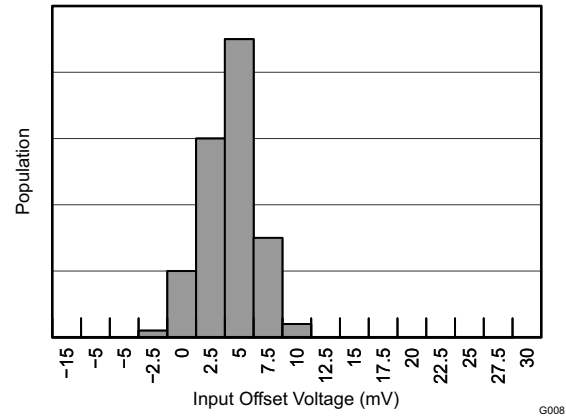

Figure 9.

**BUS INPUT OFFSET VOLTAGE vs TEMPERATURE**

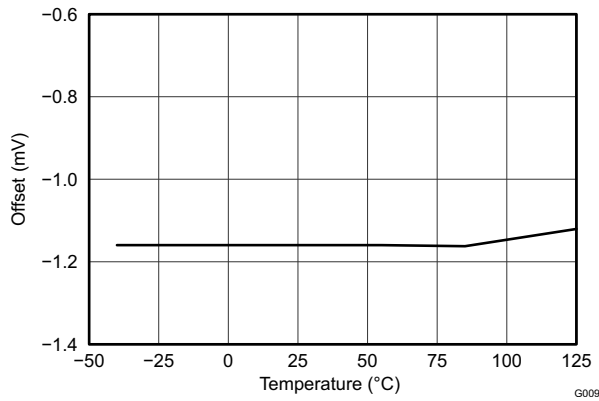

Figure 10.

**BUS INPUT GAIN ERROR PRODUCTION DISTRIBUTION**

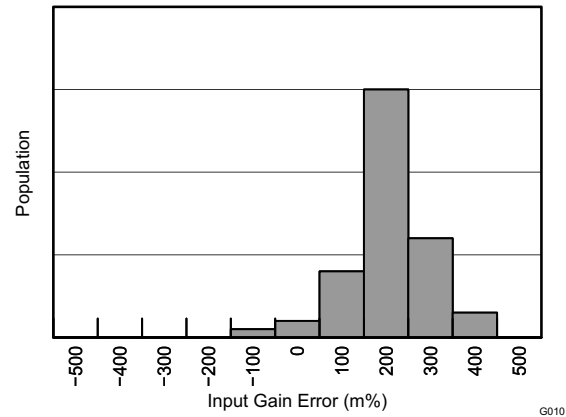

Figure 11.

**BUS INPUT GAIN ERROR vs TEMPERATURE**

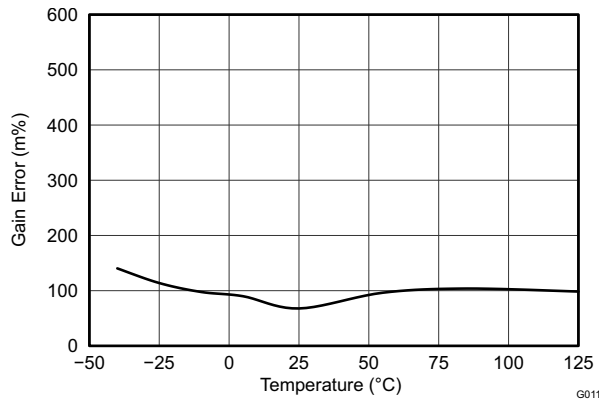

Figure 12.

**INPUT BIAS CURRENT vs COMMON-MODE VOLTAGE**

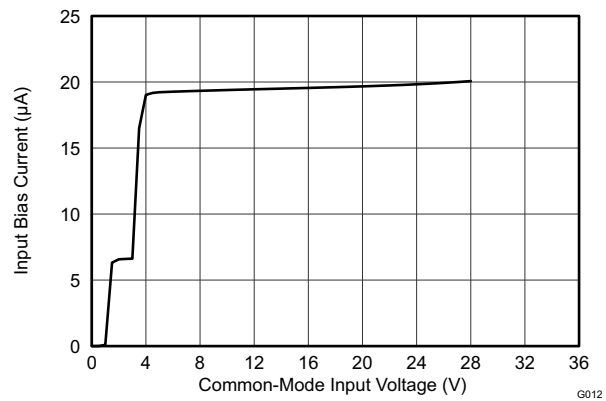

Figure 13.

**TYPICAL CHARACTERISTICS (continued)**

At  $T_A = +25^\circ\text{C}$ ,  $V_S = +3.3\text{ V}$ ,  $V_{IN+} = 12\text{ V}$ ,  $V_{SENSE} = (V_{IN+} - V_{IN-}) = 0\text{ mV}$ , and  $V_{BUS} = 12\text{ V}$ , unless otherwise noted.

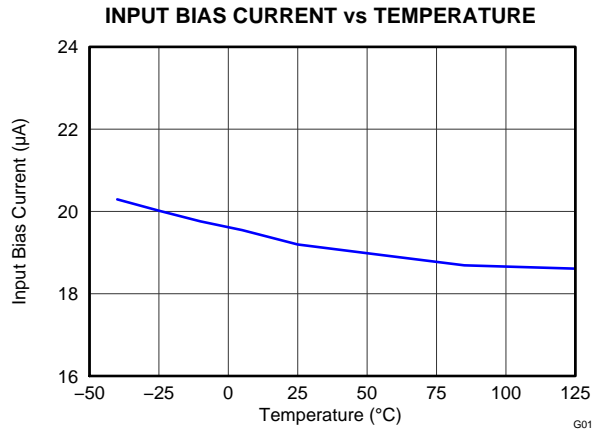

Figure 14.

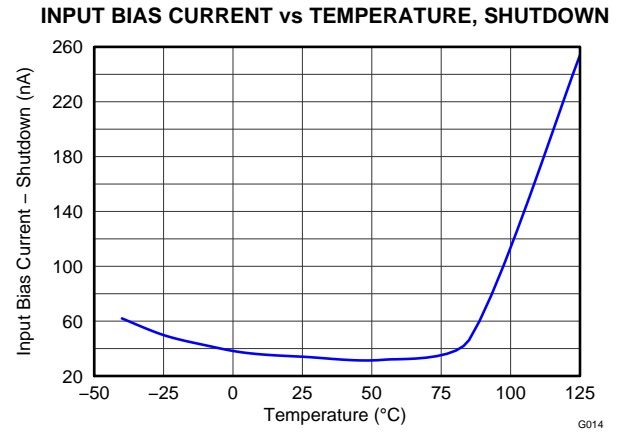

Figure 15.

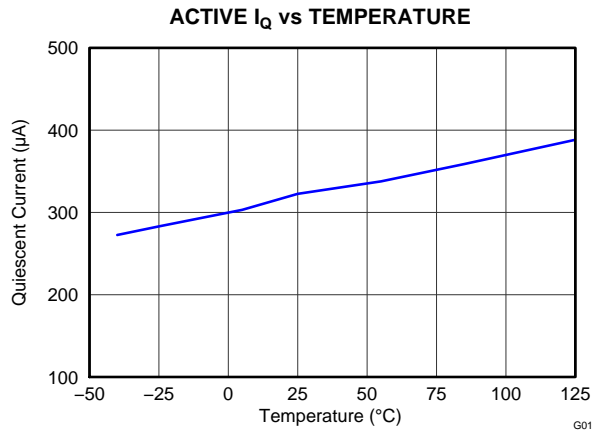

Figure 16.

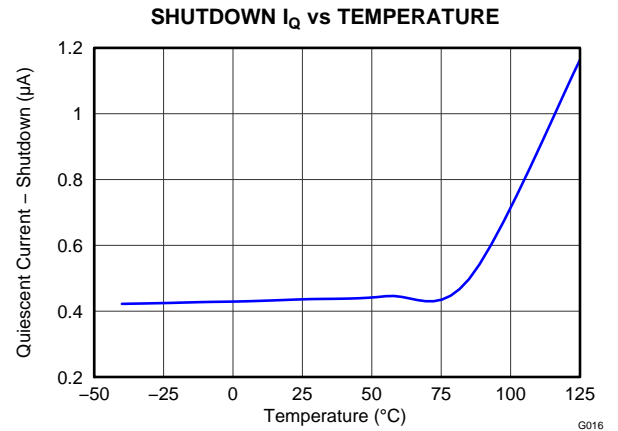

Figure 17.

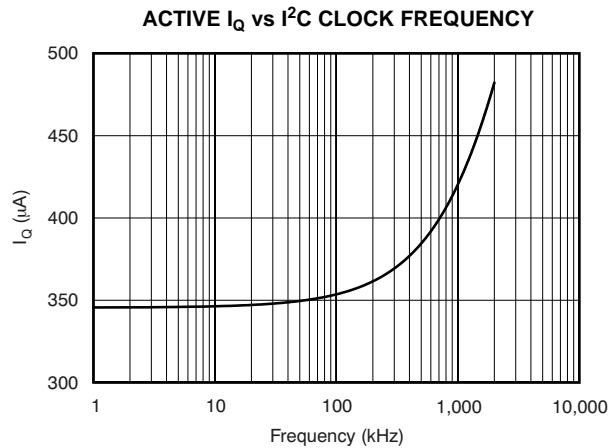

Figure 18.

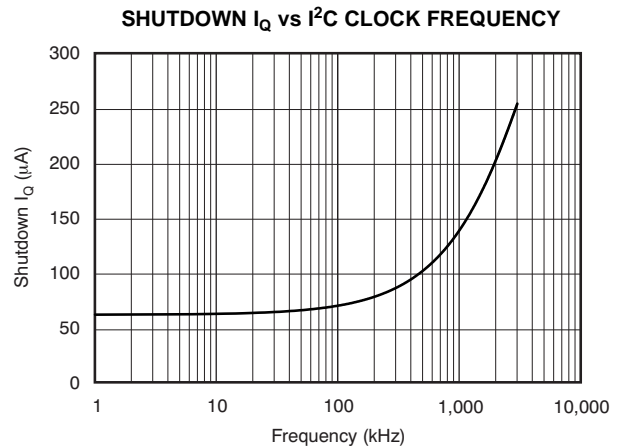

Figure 19.

## APPLICATION INFORMATION

The INA230 is a digital current shunt monitor with an I<sup>2</sup>C- and SMBus-compatible interface. This device provides digital current, voltage, and power readings necessary for accurate decision-making in precisely-controlled systems. Programmable registers allow flexible configuration for measurement resolution, as well as continuous-versus-triggered operation. Detailed register information appears towards the end of this data sheet, beginning with [Table 2](#). See [Figure 1](#) for a block diagram of the INA230.

### INA230 TYPICAL APPLICATION

The [figure](#) on the front page shows a typical application circuit for the INA230. For power-supply bypassing, use a 0.1- $\mu$ F ceramic capacitor placed as close as possible to the supply and ground pins.

### BASIC ANALOG-TO-DIGITAL CONVERTER (ADC) FUNCTIONS

The INA230 performs two measurements on the power-supply bus of interest. The voltage developed from the load current that flows through a shunt resistor creates the shunt voltage signal that is measured at the IN+ and IN– pins. The device can also measure the power supply bus voltage by connecting this voltage to the BUS pin. The differential shunt voltage is measured with respect to the IN– pin while the bus voltage is measured with respect to ground.

The INA230 is typically powered by a separate supply that can range from 2.7 V to 5.5 V. The bus that is being monitored can range in voltage from 0 V to 28 V. **NOTE: Based on the fixed 1.25 mV LSB for the bus voltage register, a full-scale register would result in a 40.96-V value. However, the actual voltage that is applied to the input pins of the INA230 should not exceed 28 V.** There are no special considerations for power-supply sequencing because the common-mode input range and power-supply voltage are independent of each other; therefore, the bus voltage can be present with the supply voltage off, and vice-versa.

As noted, the INA230 takes two measurements, shunt voltage and bus voltage. It then converts these measurements to current, based on the Calibration register value, and then calculates power. Refer to the [Configure/Measure/Calculate Example](#) section for additional information on programming the Calibration register.

The INA230 has two operating modes, continuous and triggered, that determine how the ADC operates after these conversions. When the INA230 is in the normal operating mode (that is, the MODE bits of the Configuration register are set to '111'), it continuously converts a shunt voltage reading followed by a bus voltage reading. After the shunt voltage reading, the current value is calculated based on [Equation 3](#). This current value is then used to calculate the power result using [Equation 4](#). These values are subsequently stored in an accumulator, and the measurement/calculation sequence repeats until the number of averages set in the Configuration register is reached. Note that the current and power calculations are based on the value programmed into the Calibration register. If the Calibration register is not programmed, the result of the current and power calculations is zero. Following every sequence, the present set of measured and calculated values are appended to the previously collected values. After all of the averaging has been completed, the final values for shunt voltage, bus voltage, current, and power are updated in the corresponding registers and can then be read. These values remain in the data output registers until they are replaced by the next fully completed conversion results. Reading the data output registers does not affect a conversion in progress.

The mode control bits in the Configuration register also permit selecting specific modes to convert only the shunt voltage or the bus voltage in order to further allow the monitoring function configuration to fit specific application requirements.

All current and power calculations are performed in the background and do not contribute to conversion time.

In triggered mode, writing any of the triggered convert modes into the Configuration register (that is, the MODE bits of the Configuration register are set to '001', '010', or '011') triggers a single-shot conversion. This action produces a single set of measurements. To trigger another single-shot conversion, the Configuration register must be written to again, even if the mode does not change.

In addition to the two operating modes (continuous and triggered), the INA230 also has a power-down mode that reduces the quiescent current and turns off current into the INA230 inputs, which reduces the impact of supply drain when the device is not being used. Full recovery from power-down mode requires 40 ms. The registers of the INA230 can be written to and read from while the device is in power-down mode. The device remains in power-down mode until one of the active modes settings are written into the Configuration register.

Although the INA230 can be read at any time, and the data from the last conversion remain available, the Conversion Ready Flag bit (CVRF bit, Mask/Enable register) is provided to help coordinate single-shot or triggered conversions. The CVRF bit is set after all conversions, averaging, and multiplication operations are complete for a single cycle.

The CVRF bit clears under these conditions:

1. Writing to the Configuration register, except when configuring the MODE bits for power-down mode; or
2. Reading the Status register.

### Power Calculation

The current and power are calculated after shunt voltage and bus voltage measurements, as shown in Figure 20. The current is calculated after a shunt voltage measurement based on the value set in the Calibration register. If there is no value loaded into the Calibration register, the current value stored is zero. Power is calculated following the bus voltage measurement based on the previous current calculation and bus voltage measurement. If there is no value loaded in the Calibration register, the power value stored is also zero. These calculations are performed in the background and do not add to the overall conversion time. These current and power values are considered intermediate results (unless the averaging is set to 1) and are stored in an internal accumulation register, not the corresponding output registers. Following every measured sample, the newly-calculated values for current and power are appended to this accumulation register until all of the samples have been measured and averaged based on the number of averages set in the Configuration register.

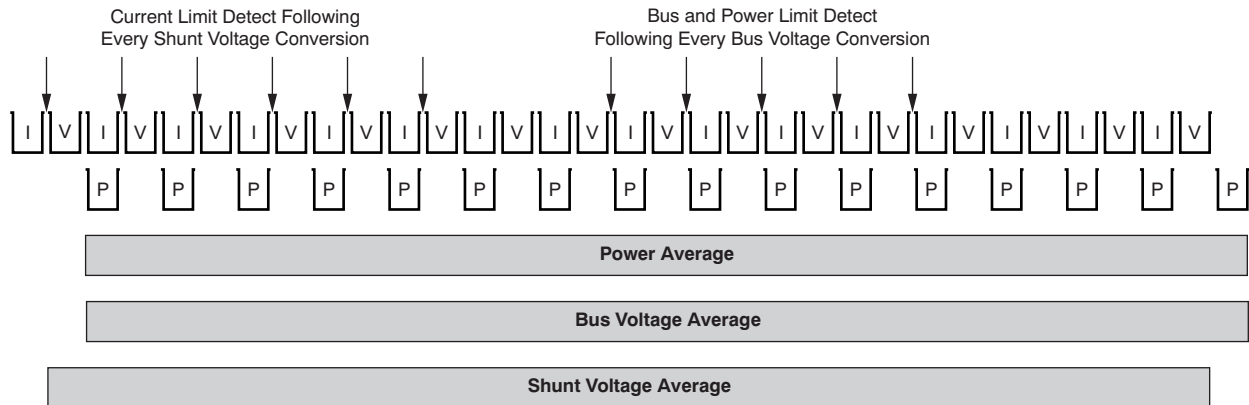

Figure 20. Power Calculation Scheme

In addition to the current and power accumulating after every sample, the shunt and bus voltage measurements are also collected. Once all of the samples have been measured and the corresponding current and power calculations have been made, the accumulated average for each of these parameters is then loaded to the corresponding output registers, where they can then be read.

## Averaging and Conversion Time Considerations

The INA230 has programmable conversion times for both the shunt voltage and bus voltage measurements. The conversion times for these measurements can be selected from as fast as 140  $\mu\text{s}$  to as long as 8.244 ms. The conversion time settings, along with the programmable averaging mode, allow the INA230 to be configured to optimize the available timing requirements in a given application. For example, if a system requires that data be read every 5 ms, the INA230 can be configured with the conversion times set to 588  $\mu\text{s}$  and the averaging mode set to 4. This configuration results in the data updating approximately every 4.7 ms. The INA230 can also be configured with a different conversion time setting for the shunt and bus voltage measurements. This type of approach is common in applications where the bus voltage tends to be relatively stable. This situation allows for the time spent measuring the bus voltage to be reduced relative to the shunt voltage measurement. The shunt voltage conversion time can be set to 4.156 ms with the bus voltage conversion time set to 588  $\mu\text{s}$ , and the averaging mode set to 1. This configuration also results in data updating approximately every 4.7 ms.

There are trade-offs associated with the settings for conversion time and the averaging mode used. The averaging feature can significantly improve the measurement accuracy by effectively filtering the signal. This approach allows the INA230 to reduce noise in the measurement that may be caused by noise coupling into the signal. A greater number of averages enables the INA230 to be more effective in reducing the noise component of the measurement.

The conversion times selected can also have an impact on the measurement accuracy; this effect can be seen in [Figure 21](#). Multiple conversion times are shown here to illustrate the impact of noise on the measurement. In order to achieve the highest accuracy measurement possible, a combination of the longest allowable conversion times and highest number of averages should be used, based on the timing requirements of the system.

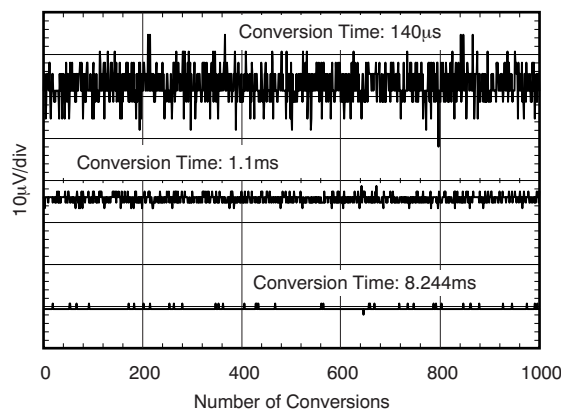

**Figure 21. Noise vs Conversion Time**

## Filtering and Input Considerations

Measuring current is often a noisy task, and such noise can be difficult to define. The INA230 offers several options for filtering by allowing the conversion times and number of averages to be independently selected in the Configuration register. The conversion times can be independently set for the shunt voltage and bus voltage measurements to allow added flexibility in configuring the monitoring of the power-supply bus.

The internal ADC is based on a delta-sigma ( $\Delta\Sigma$ ) front-end with a 500 kHz ( $\pm 30\%$ ) typical sampling rate. This architecture has good inherent noise rejection; however, transients that occur at or very close to the sampling rate harmonics can cause problems. Because these signals are at 1 MHz and higher, they can be managed by incorporating filtering at the input of the INA230. The high frequency enables the use of low-value series resistors on the filter with negligible effects on measurement accuracy. In general, filtering the INA230 input is only necessary if there are transients at exact harmonics of the 500-kHz ( $\pm 30\%$ ) sampling rate (greater than 1 MHz). Filter using the lowest possible series resistance (typically 10  $\Omega$  or less) and a ceramic capacitor. Recommended values for this capacitor are 0.1  $\mu\text{F}$  to 1.0  $\mu\text{F}$ . Figure 22 shows the INA230 with an additional filter added at the input.

Overload conditions are another consideration for the INA230 inputs. The INA230 inputs are specified to tolerate 30 V across the inputs. A large differential scenario might be a short to ground on the load side of the shunt. This type of event can result in full power-supply voltage across the shunt (as long as the power supply or energy storage capacitors support it). Keep in mind that removing a short to ground can result in inductive kickbacks that could exceed the 30-V differential and common-mode rating of the INA230. Inductive kickback voltages are best controlled by zener-type transient-absorbing devices (commonly called *transzorb*s) combined with sufficient energy storage capacitance.

In applications that do not have large energy-storage electrolytics on one or both sides of the shunt, an input overstress condition may result from an excessive  $dV/dt$  of the voltage applied to the input. A hard physical short is the most likely cause of this event, particularly in applications with no large electrolytics present. This problem occurs because an excessive  $dV/dt$  can activate the ESD protection in the INA230 in systems where large currents are available. Testing has demonstrated that the addition of 10- $\Omega$  resistors in series with each input of the INA230 sufficiently protect the inputs against this  $dV/dt$  failure up to the 30-V rating of the INA230. Selecting these resistors in the range noted has minimal effect on accuracy.

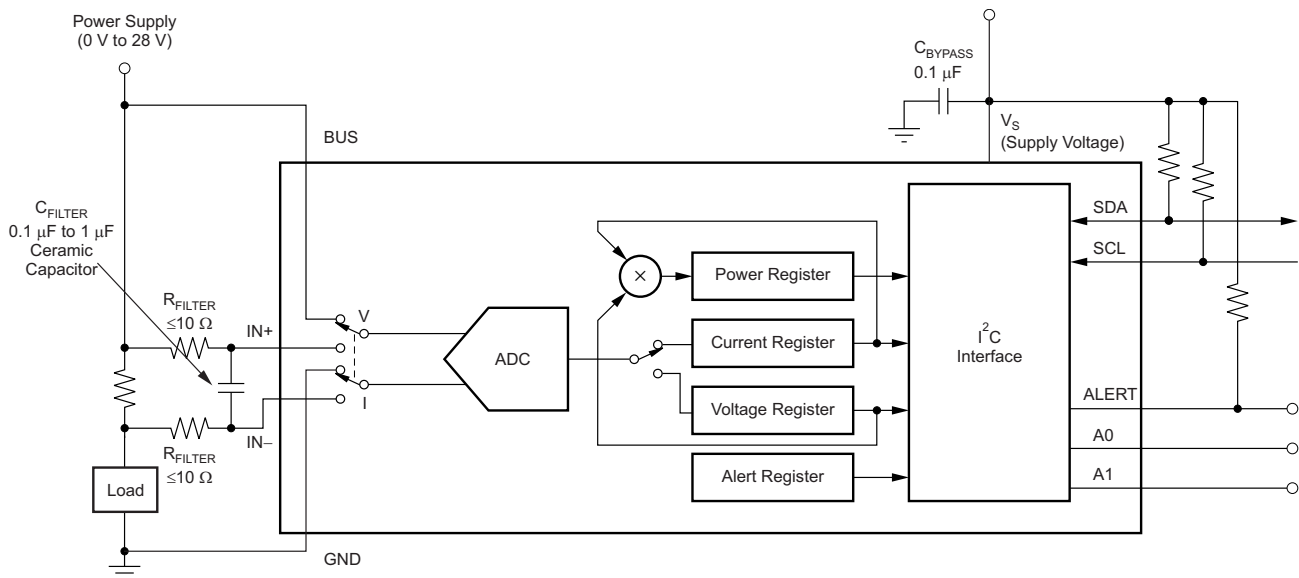

Figure 22. INA230 with Input Filtering

## ALERT PIN

The INA230 has a single Alert Limit register (07h) that allows the ALERT pin to be programmed to respond to a single user-defined event or to a conversion ready notification if desired. The Mask/Enable register allows for selection from one of the five available functions to monitor and/or set the conversion ready bit (CNVR, Mask/Enable register) to control the response of the ALERT pin. Based on the function being monitored, a value would then be entered into the Alert Limit register to set the corresponding threshold value that asserts the ALERT pin.

The ALERT pin allows for one of several available alert functions to be monitored to determine if a user-defined threshold has been exceeded. The five alert functions that can be monitored are:

- Shunt Voltage Over Limit (SOL)
- Shunt Voltage Under Limit (SUL)
- Bus Voltage Over Limit (BOL)
- Bus Voltage Under Limit (BUL)
- Power Over Limit (POL)

The ALERT pin is an open-drain output. This pin is asserted when the alert function selected in the Mask/Enable register exceeds the value programmed into the Alert Limit register. Only one of these alert functions can be enabled and monitored at a time. If multiple alert functions are enabled, the selected function in the highest significant bit position takes priority and responds to the Alert Limit register value. For example, if the SOL and the SUL are both selected, the ALERT pin asserts when the Shunt Voltage Over Limit register exceeds the value in the Alert Limit register.

The conversion ready state of the device can also be monitored at the ALERT pin to inform the user when the device has completed the previous conversion and is ready to begin a new conversion. The conversion ready flag (CVRF) bit can be monitored at the ALERT pin along with one of the alert functions. If an alert function and the CNVR bit are both enabled to be monitored at the ALERT pin, then after the ALERT pin is asserted, the Mask/Enable register must be read following the alert to determine the source of the alert. By reading the CVRF bit (D3), and the AFF bit (D4) in the Mask/Enable register, the source of the alert can be determined. If the conversion ready feature is not desired, and the CNVR bit is not set, the ALERT pin only responds to an exceeded alert limit based on the alert function enabled.

If the alert function is not used, the ALERT pin can be left floating without impacting the operation of the device.

Refer to [Figure 20](#) to see the relative timing of when the value in the Alert Limit register is compared to the corresponding converted value. For example, if the alert function that is enabled is Shunt Voltage Over Limit (SOL), following every shunt voltage conversion the value in the Alert Limit register is compared to the measured shunt voltage to determine if the measurements have exceeded the programmed limit. The AFF bit (D4, Mask/Enable register) asserts high any time the measured voltage exceeds the value programmed into the Alert Limit register. In addition to the AFF bit being asserted, the ALERT pin is asserted based on the Alert Polarity bit (APOL, D1, Mask/Enable register). If the Alert Latch is enabled, the AFF bit and ALERT pin remain asserted until either the Configuration register is written to or the Mask/Enable register is read.

The bus voltage alert functions (BOL and BUL, Mask/Enable register) compare the measured bus voltage to the Alert Limit register following every bus voltage conversion and assert the AFF bit and ALERT pin if the limit threshold is exceeded.

The power over limit alert function (POL, Mask/Enable Register) is also compared to the calculated power value following every bus voltage measurement conversion and asserts the AFF bit and ALERT pin if the limit threshold is exceeded.

With the alert function comparing the programmed alert limit value to the result of each corresponding conversion, it is possible to have an alert issued during a conversion cycle where the averaged value of the signal does not exceed the alert limit. The triggering of the alert based on this intermediate conversion allows for out-of-range events to be detected more quickly than the averaged output data registers are updated. This can be used to create alert limits for quickly changing conditions through the use of the alert function, as well as to create limits to longer-duration conditions through software monitoring of the averaged output values.

## PROGRAMMING THE INA230

An important aspect of the INA230 is that it does not necessarily measure current or power. The INA230 measures both the differential voltage applied between the IN+ and IN– input pins and the voltage applied to the BUS pin. In order for the INA230 to report both current and power values, both the Current register resolution and the value of the shunt resistor present in the application that resulted in the differential voltage being developed must be programmed. The Power register is internally set to be 25 times the programmed least significant bit of the current register (Current\_LSB). Both the Current\_LSB and shunt resistor value are used when calculating the Calibration register value. The INA230 uses this value to calculate the corresponding current and power values based on the measured shunt and bus voltages.

The Calibration register is calculated based on [Equation 1](#). This equation includes the term Current\_LSB, the programmed value for the LSB for the Current register. This is the value used to convert the value in the Current register to the actual current in amps. The highest resolution for the Current register can be obtained by using the smallest allowable Current\_LSB based on the maximum expected current, as shown in [Equation 2](#). While this value yields the highest resolution, it is common to select a value for the Current\_LSB to the nearest round number above this value to simplify the conversion of the Current register and Power register to amps and watts respectively. R<sub>SHUNT</sub> is the value of the external shunt used to develop the differential voltage across the input pins. The 0.00512 value in [Equation 1](#) is an internal fixed value used to ensure scaling is maintained properly.

$$\text{CAL} = \frac{0.00512}{\text{Current\_LSB} \cdot \text{R}_{\text{SHUNT}}} \quad (1)$$

$$\text{Current\_LSB} = \frac{\text{Maximum Expected Current}}{2^{15}} \quad (2)$$

After the Calibration register has been programmed, the Current register and Power register are updated accordingly based on the corresponding shunt voltage and bus voltage measurements. Until the Calibration register is programmed, the Current and Power registers remain at zero.

## CONFIGURE/MEASURE/CALCULATE EXAMPLE

In this example, shown in [Figure 23](#), a nominal 10-A load creates a differential voltage of 20 mV across a 2-mΩ shunt resistor. The bus voltage for the INA230 is measured at the external BUS input pin; in this example, BUS is connected to the IN– pin to measure the voltage level delivered to the load. For this example, the BUS pin measures less than 12 V because the voltage at the IN– pin is 11.98 V as a result of the voltage drop across the shunt resistor.

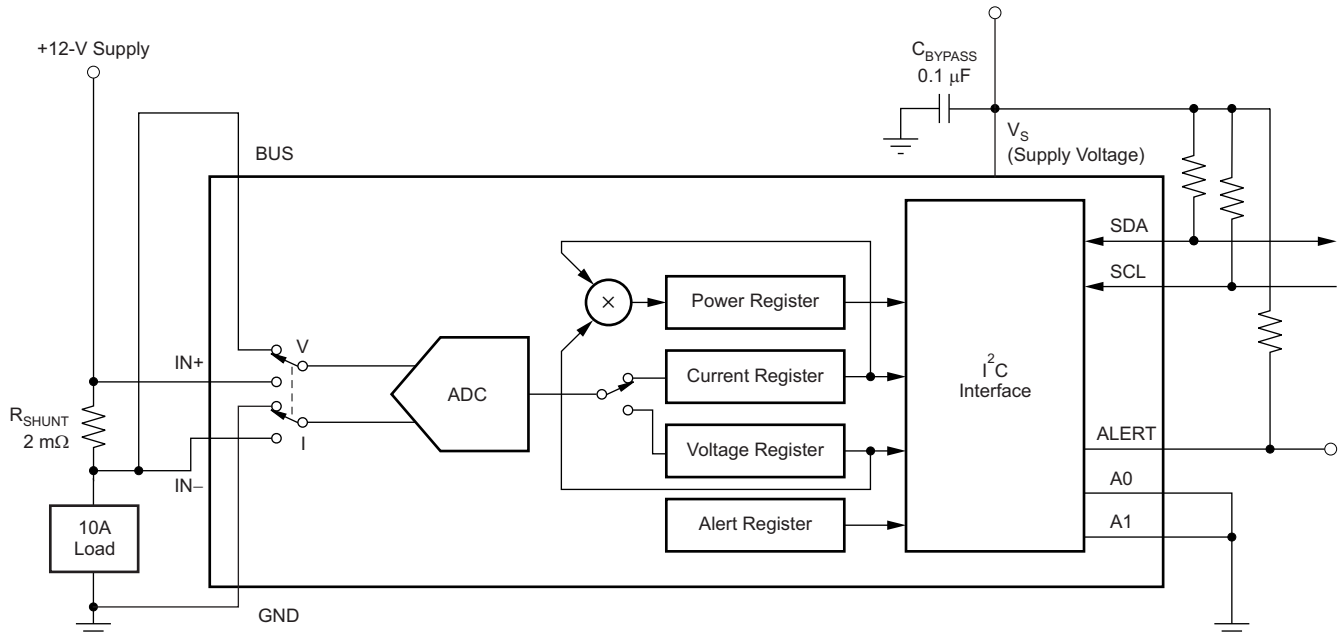

**Figure 23. Example Circuit Configuration**

For this example, assuming a maximum expected current of 15 A, the Current\_LSB is calculated to be 457.7 μA/bit using [Equation 2](#). Using a value of 500 μA/bit or 1 mA/bit for the Current\_LSB significantly simplifies the conversion from the Current register and Power register to amps and watts. For this example, a value of 1 mA/bit was chosen for the Current register LSB. Using this value for the Current\_LSB trades a small amount of resolution for a simpler conversion process on the processor side. Using [Equation 1](#) in this example with a current LSB of 1 mA/bit and a shunt resistor of 2 mΩ results in a Calibration register value of 2560, or A00h.

The Current register (04h) is then calculated by multiplying the decimal value of the Shunt Voltage register contents by the decimal value of the Calibration register and then dividing by 2048, as shown in [Equation 3](#). For this example, the Shunt Voltage register contains a value of 8,000, which is multiplied by the Calibration register value of 2560 and then divided by 2048 to yield a decimal value for the Current register of 10000, or 2710h. Multiplying this value by 1 mA/bit results in the original 10-A level stated in the example.

$$\text{Current} = \frac{\text{ShuntVoltage} \cdot \text{CalibrationRegister}}{2048} \quad (3)$$

The LSB for the Bus Voltage register (02h) is a fixed 1.25 mV/bit. This fixed value means that the 11.98V present at the BUS pin results in a register value of 2570h, or a decimal equivalent of 9584. Note that the MSB of the Bus Voltage register is always zero because the BUS pin is only able to measure positive voltages.

The Power register (03h) is then calculated by multiplying the decimal value of the Current register, 10000, by the decimal value of the Bus Voltage register, 9584, and then dividing by 20,000, as defined in [Equation 4](#). For this example, the result for the Power register is 12B8h, or a decimal equivalent of 4792. Multiplying this result by the power LSB (25 times the [ $1 \times 10^{-3}$  Current\_LSB]) results in a power calculation of ( $4792 \times 25$  mW/bit), or 119.8 W. The Power register LSB has a fixed ratio to the Current register LSB of 25 W/bit to 1 A/bit. For this example, a programmed Current register LSB of 1 mA/bit results in a Power register LSB of 25 mW/bit. This ratio is internally programmed to ensure that the scaling of the power calculation is within an acceptable range. A manual calculation for the power being delivered to the load would use a bus voltage of 11.98 V ( $12V_{CM} - 20$  mV shunt drop) multiplied by the load current of 10 A to give a result of 119.8 W.

$$\text{Power} = \frac{\text{Current} \cdot \text{BusVoltage}}{20,000} \quad (4)$$

[Table 1](#) shows the steps for configuring, measuring, and calculating the values for current and power for this device.

**Table 1. Configure/Measure/Calculate Example<sup>(1)</sup>**

STEP #	REGISTER NAME	ADDRESS	CONTENTS	DEC	LSB	VALUE
Step 1	Configuration	00h	4127h	—	—	—
Step 2	Shunt	01h	1F40h	8000	2.5 $\mu$ V	20m V
Step 3	Bus	02h	2570h	9584	1.25 mV	11.98 V
Step 4	Calibration	05h	A00h	2560	—	—
Step 5	Current	04h	2710	10000	1 mA	10 A
Step 6	Power	03h	12B8h	4792	25 mW	119.8 W

(1) Conditions: Load = 10 A,  $V_{CM} = 12$  V,  $R_{SHUNT} = 2$  m $\Omega$ , and  $V_{BUS} = 11.98$  V.

## PROGRAMMING THE INA230 POWER MEASUREMENT ENGINE

### Calibration Register and Scaling

The Calibration register makes it possible to set the scaling of the Current and Power registers to the values that are most useful for a given application. One strategy may be to set the Calibration register so that the largest possible number is generated in the Current register or Power register at the expected full-scale point. This approach yields the highest resolution based on the previously calculated minimum Current\_LSB in the equation for the Calibration register ([Equation 1](#)). The Calibration register can also be selected to provide values in the Current and Power registers that either provide direct decimal equivalents of the values being measured, or yield a round LSB value for each corresponding register. After these choices have been made, the Calibration register also offers possibilities for end-user, system-level calibration. By physically measuring the current with an external ammeter, the exact current is known. The value of the Calibration register can then be adjusted based on the measured current result of the INA230 to cancel the total system error, as shown in [Equation 5](#).

$$\text{Corrected\_Full\_Scale\_Cal} = \text{trunc} \left( \frac{\text{Cal} \times \text{MeasShuntCurrent}}{\text{INA230\_Current}} \right) \quad (5)$$

## Simple Current Shunt Monitor Usage (No Programming Necessary)

The INA230 can be used without any programming if it is only necessary to read a shunt voltage drop and bus voltage with the default power-on reset configuration and continuous conversion of shunt and bus voltage.

Without programming the INA230 Calibration register, the device is unable to provide either a valid current or power value, because these outputs are both derived using the values loaded into the Calibration register.

## Default INA230 Settings

The default power-up states of the registers are shown in the [INA230 Register Descriptions](#) section of this data sheet. These registers are volatile, and if programmed to a value other than the default values shown in [Table 2](#), they must be reprogrammed at every device power-up. Detailed information on programming the Calibration register is given in the [Configure/Measure/Calculate Example](#) section and calculated based on [Equation 1](#).

## REGISTER INFORMATION

The INA230 uses a bank of registers for holding configuration settings, measurement results, minimum/maximum limits, and status information. [Table 2](#) summarizes the INA230 registers; refer to [Figure 1](#) for an illustration of the registers.

**Table 2. Summary of Register Set**

POINTER ADDRESS	REGISTER NAME	FUNCTION	POWER-ON RESET		TYPE <sup>(1)</sup>
			BINARY	HEX	
00	Configuration	All-register reset, shunt voltage and bus voltage ADC conversion times and averaging, operating mode	01000001 00100111	4127	R/W
01	Shunt Voltage	Shunt voltage measurement data	00000000 00000000	0000	R
02	Bus Voltage	Bus voltage measurement data	00000000 00000000	0000	R
03	Power <sup>(2)</sup>	Contains the value of the calculated power being delivered to the load.	00000000 00000000	0000	R
04	Current <sup>(2)</sup>	Contains the value of the calculated current flowing through the shunt resistor.	00000000 00000000	0000	R
05	Calibration	Sets full-scale range and LSB of current and power measurements. Overall system calibration.	00000000 00000000	0000	R/W
06	Mask/Enable	Alert configuration and conversion ready flag	00000000 00000000	0000	R/W
07	Alert Limit	Contains the limit value to compare to the selected alert function.	00000000 00000000	0000	R/W
FF	Die ID	Contains unique die identification number.	ASCII	ASCII	R

(1) Type: R = read-only, R/W = read/write.

(2) The Current register defaults to '0' because the Calibration register defaults to '0', yielding a zero current and power value until the Calibration register is programmed.

## REGISTER DETAILS

All 16-bit INA230 registers are two 8-bit bytes via the I<sup>2</sup>C interface.

### Configuration Register (00h, Read/Write)

BIT #	D15	D14	D13	D12	D11	D10	D9	D8	D7	D6	D5	D4	D3	D2	D1	D0
BIT NAME	RST	—	—	—	AVG2	AVG1	AVG0	V <sub>BUS</sub> CT2	V <sub>BUS</sub> CT1	V <sub>BUS</sub> CT0	V <sub>SH</sub> CT2	V <sub>SH</sub> CT1	V <sub>SH</sub> CT0	MODE3	MODE2	MODE1
POR VALUE	0	1	0	0	0	0	0	1	0	0	1	0	0	1	1	1

The Configuration register settings control the operating modes for the INA230. This register controls the conversion time settings for both the shunt and bus voltage measurements, as well as the averaging mode used. The operating mode that controls which signals are selected to be measured is also programmed in the Configuration register.

The Configuration register can be read from at any time without impacting or affecting the device settings or a conversion in progress. Writing to the Configuration register halts any conversion in progress until the write sequence is complete, resulting in the start of a new conversion based on the new contents of the Configuration register. This feature prevents any uncertainty in the conditions used for the next completed conversion.

### Bit Descriptions

<b>RST:</b> Bit 15	<b>Reset Bit</b> Setting this bit to '1' generates a system reset that is the same as a power-on reset; all registers are reset to default values. This bit self-clears.
<b>AVG:</b> Bits 9–11	<b>Averaging Mode</b> Sets the number of samples that are collected and averaged together. <a href="#">Table 3</a> summarizes the AVG bit settings and related number of averages for each bit.

**Table 3. AVG Bit Settings [11:9]<sup>(1)</sup>**

AVG2 (D11)	AVG1 (D10)	AVG0 (D9)	NUMBER OF AVERAGES
0	0	0	1
0	0	1	4
0	1	0	16
0	1	1	64
1	0	0	128
1	0	1	256
1	1	0	512
1	1	1	1024

(1) Shaded values are default.

**V<sub>BUS</sub> CT:**

Bits 6–8

**Bus Voltage Conversion Time**

Sets the conversion time for the bus voltage measurement. [Table 4](#) shows the V<sub>BUS</sub> CT bit options and related conversion times for each bit.

**Table 4. V<sub>BUS</sub> CT Bit Settings [8:6]<sup>(1)</sup>**

V <sub>BUS</sub> CT2 (D8)	V <sub>BUS</sub> CT1 (D7)	V <sub>BUS</sub> CT0 (D6)	CONVERSION TIME
0	0	0	140 μs
0	0	1	204 μs
0	1	0	332 μs
0	1	1	588 μs
1	0	0	1.1 ms
1	0	1	2.116 ms
1	1	0	4.156 ms
1	1	1	8.244 ms

(1) Shaded values are default.

**V<sub>SH</sub> CT:**

Bits 3–5

**Shunt Voltage Conversion Time**

Sets the conversion time for the shunt voltage measurement. [Table 5](#) shows the V<sub>SH</sub> CT bit options and related conversion times for each bit.

**Table 5. V<sub>SH</sub> CT Bit Settings [5:3]<sup>(1)</sup>**

V <sub>SH</sub> CT2 (D5)	V <sub>SH</sub> CT1 (D4)	V <sub>SH</sub> CT0 (D3)	CONVERSION TIME
0	0	0	140 μs
0	0	1	204 μs
0	1	0	332 μs
0	1	1	588 μs
1	0	0	1.1 ms
1	0	1	2.116 ms
1	1	0	4.156 ms
1	1	1	8.244 ms

(1) Shaded values are default.

**MODE:**

Bits 0–2

**Operating Mode**

Selects continuous, triggered, or power-down mode of operation. These bits default to continuous shunt and bus measurement mode. The mode settings are shown in [Table 6](#).

**Table 6. Mode Settings [2:0]<sup>(1)</sup>**

MODE3 (D2)	MODE2 (D1)	MODE1 (D0)	MODE
0	0	0	Power-Down
0	0	1	Shunt Voltage, triggered
0	1	0	Bus Voltage, triggered
0	1	1	Shunt and Bus, triggered
1	0	0	Power-Down
1	0	1	Shunt Voltage, continuous
1	1	0	Bus Voltage, continuous
1	1	1	Shunt and Bus, continuous

(1) Shaded values are default.

## DATA OUTPUT REGISTERS

### Shunt Voltage Register (01h, Read-Only)

The Shunt Voltage register stores the current shunt voltage reading,  $V_{SHUNT}$ . Negative numbers are represented in twos complement format. Generate the twos complement of a negative number by complementing the absolute value binary number and adding 1. Extend the sign, denoting a negative number by setting the MSB = '1'.

**Example:** For a value of  $V_{SHUNT} = -80$  mV:

1. Take the absolute value: 80mV
2. Translate this number to a whole decimal number ( $80 \text{ mV} \div 2.5 \mu\text{V}$ ) = 32000
3. Convert this number to binary = 111 1101 0000 0000
4. Complement the binary result = 000 0010 1111 1111
5. Add '1' to the complement to create the twos complement result = 000 0011 0000 0000
6. Extend the sign and create the 16-bit word: 1000 0011 0000 0000 = 8300h

If averaging is enabled, this register displays the averaged value. Full-scale range = 81.9175 mV (decimal = 7FFF); LSB: 2.5  $\mu\text{V}$ .

BIT #	D15	D14	D13	D12	D11	D10	D9	D8	D7	D6	D5	D4	D3	D2	D1	D0
BIT NAME	SIGN	SD14	SD13	SD12	SD11	SD10	SD9	SD8	SD7	SD6	SD5	SD4	SD3	SD2	SD1	SD0
POR VALUE	0	0	0	0	0	0	0	0	0	0	0	0	0	0	0	0

### Bus Voltage Register (02h, Read-Only)<sup>(1)</sup>

The Bus Voltage register stores the most recent bus voltage reading,  $V_{BUS}$ .

If averaging is enabled, this register displays the averaged value. Full-scale range = 40.95875 V (decimal = 7FFF); LSB = 1.25 mV. Do not apply more than 28 V on the BUS pin.

BIT #	D15	D14	D13	D12	D11	D10	D9	D8	D7	D6	D5	D4	D3	D2	D1	D0
BIT NAME	—	BD14	BD13	BD12	BD11	BD10	BD9	BD8	BD7	BD6	BD5	BD4	BD3	BD2	BD1	BD0
POR VALUE	0	0	0	0	0	0	0	0	0	0	0	0	0	0	0	0

(1) D15 is always zero because bus voltage can only be positive.

### Power Register (03h, Read-Only)

If averaging is enabled, this register displays the averaged value.

BIT #	D15	D14	D13	D12	D11	D10	D9	D8	D7	D6	D5	D4	D3	D2	D1	D0
BIT NAME	PD15	PD14	PD13	PD12	PD11	PD10	PD9	PD8	PD7	PD6	PD5	PD4	PD3	PD2	PD1	PD0
POR VALUE	0	0	0	0	0	0	0	0	0	0	0	0	0	0	0	0

The Power register LSB is internally programmed to equal 25 times the programmed value of the Current\_LSB.

The Power register records power in watts by multiplying the decimal values of the current register with the decimal value of the bus voltage register according to [Equation 4](#).

### Current Register (04h, Read-Only)

If averaging is enabled, this register displays the averaged value.

BIT #	D15	D14	D13	D12	D11	D10	D9	D8	D7	D6	D5	D4	D3	D2	D1	D0
BIT NAME	CSIGN	CD14	CD13	CD12	CD11	CD10	CD9	CD8	CD7	CD6	CD5	CD4	CD3	CD2	CD1	CD0
POR VALUE	0	0	0	0	0	0	0	0	0	0	0	0	0	0	0	0

The value of the Current register is calculated by multiplying the decimal value in the Shunt Voltage register with the decimal value of the Calibration register, according to [Equation 3](#).

### Calibration Register (05h, Read/Write)

This register provides the INA230 with the shunt resistor value that was present to create the measured differential voltage. This register also sets the resolution of the Current register. The Current register LSB and Power register LSB are set through the programming of this register. This register is also used for overall system calibration. See the [Configure/Measure/Calculate Example](#) for more information on programming this register.

BIT #	D15	D14	D13	D12	D11	D10	D9	D8	D7	D6	D5	D4	D3	D2	D1	D0
BIT NAME	—	FS14	FS13	FS12	FS11	FS10	FS9	FS8	FS7	FS6	FS5	FS4	FS3	FS2	FS1	FS0
POR VALUE	0	0	0	0	0	0	0	0	0	0	0	0	0	0	0	0

### Mask/Enable Register (06h, Read/Write)

The Mask/Enable register selects the function that controls the ALERT pin, as well as how that pin functions. If multiple functions are enabled, the highest significant bit position alert function (D15:D11) takes priority and responds to the Alert Limit register.

BIT #	D15	D14	D13	D12	D11	D10	D9	D8	D7	D6	D5	D4	D3	D2	D1	D0
BIT NAME	SOL	SUL	BOL	BUL	POL	CNVR	—	—	—	—	—	AFF	CVRF	OVF	APOL	LEN
POR VALUE	0	0	0	0	0	0	0	0	0	0	0	0	0	0	0	0

**SOL:** **Shunt Voltage Over-Voltage**

Bit 15 Setting this bit high configures the ALERT pin to be asserted when the shunt voltage conversion exceeds the value in the Alert Limit register.

**SUL:** **Shunt Voltage Under-Voltage**

Bit 14 Setting this bit high configures the ALERT pin to be asserted when the shunt voltage conversion drops below the value in the Alert Limit register.

**BOL:** **Bus Voltage Over-Voltage**

Bit 13 Setting this bit high configures the ALERT pin to be asserted when the bus voltage conversion exceeds the value in the Alert Limit register.

**BUL:** **Bus Voltage Under-Voltage**

Bit 12 Setting this bit high configures the ALERT pin to be asserted when the bus voltage conversion drops below the value in the Alert Limit register.

**POL:** **Over-Limit Power**

Bit 11 Setting this bit high configures the ALERT pin to be asserted when the power calculation exceeds the value in the Alert Limit register.

**CNVR:** **Conversion Ready**

Bit 10 Setting this bit high configures the ALERT pin to be asserted when the Conversion Ready Flag bit (CVRF, bit 3) is asserted, indicating that the device is ready for the next conversion.

<b>AFF:</b>	<b>Alert Function Flag</b>
Bit 4	<p>Although only one alert function at a time can be monitored at the ALERT pin, the Conversion Ready bit (CNVR, bit 10) can also be enabled to assert the ALERT pin. Reading the Alert Function Flag bit after an alert can help determine if the alert function was the source of the alert.</p> <p>When the Alert Latch Enable bit is set to Latch mode, the Alert Function Flag bit clears only when the Mask/Enable register is read. When the Alert Latch Enable bit is set to Transparent mode, the Alert Function Flag bit is cleared after the next conversion that does not result in an alert condition.</p>
<b>CVRF:</b>	<b>Conversion Ready Flag</b>
Bit 3	<p>Although the INA230 can be read at any time, and the data from the last conversion are available, this bit is provided to help coordinate single-shot or triggered conversions. This bit is set after all conversions, averaging, and multiplications are complete. This bit clears under the following conditions in single-shot mode:</p> <ol style="list-style-type: none"> <li>1) Writing to the Configuration register (except for power-down or disable selections)</li> <li>2.) Reading the Mask/Enable register</li> </ol>
<b>OVF:</b>	<b>Math Overflow Flag</b>
Bit 2	This bit is set to '1' if an arithmetic operation results in an overflow error; it indicates that current and power data may be invalid.
<b>APOL:</b>	<b>Alert Polarity</b>
Bit 1	<p>Configures the latching feature of the ALERT pin and the flag bits.</p> <p>1 = Inverted (active-high open collector)</p> <p>0 = Normal (active-low open collector) (default)</p>
<b>LEN:</b>	<b>Alert Latch Enable</b>
Bit 0	<p>Configures the latching feature of the ALERT pin and flag bits.</p> <p>1 = Latch enabled</p> <p>0 = Transparent (default)</p> <p>When the Alert Latch Enable bit is set to Transparent mode, the ALERT pin and flag bits reset to their idle states when the fault has been cleared. When the Alert Latch Enable bit is set to Latch mode, the ALERT pin and flag bits remain active following a fault until the Mask/Enable register has been read.</p>

### Alert Limit Register (07h, Read/Write)

The Alert Limit register contains the value used to compare to the register selected in the Mask/Enable register to determine if a limit has been exceeded.

BIT #	D15	D14	D13	D12	D11	D10	D9	D8	D7	D6	D5	D4	D3	D2	D1	D0
BIT NAME	AUL15	AUL14	AUL13	AUL12	AUL11	AUL10	AUL9	AUL8	AUL7	AUL6	AUL5	AUL4	AUL3	AUL2	AUL1	AUL0
POR VALUE	0	0	0	0	0	0	0	0	0	0	0	0	0	0	0	0

## BUS OVERVIEW

The INA230 offers compatibility with both I<sup>2</sup>C and SMBus interfaces. The I<sup>2</sup>C and SMBus protocols are essentially compatible with one another.

The I<sup>2</sup>C interface is used throughout this data sheet as the primary example, with SMBus protocol specified only when a difference between the two systems is discussed. Two bidirectional lines, SCL and SDA, connect the INA230 to the bus. Both SCL and SDA are open-drain connections.

The device that initiates a data transfer is called a *master*, and the devices controlled by the master are *slaves*. The bus must be controlled by a master device that generates the serial clock (SCL), controls the bus access, and generates start and stop conditions.

To address a specific device, the master initiates a start condition by pulling the data signal line (SDA) from a high to a low logic level while SCL is high. All slaves on the bus shift in the slave address byte on the rising edge of SCL, with the last bit indicating whether a read or write operation is intended. During the ninth clock pulse, the slave being addressed responds to the master by generating an *Acknowledge* bit (ACK) and pulling SDA low.

Data transfer is then initiated and eight bits of data are sent, followed by an ACK. During data transfer, SDA must remain stable while SCL is high. Any change in SDA while SCL is high is interpreted as a start or stop condition.

Once all data have been transferred, the master generates a stop condition, indicated by pulling SDA from low to high while SCL is high. The INA230 includes a 28-ms timeout on its interface to prevent locking up the bus.

### Serial Bus Address

To communicate with the INA230, the master must first address slave devices using a corresponding slave address byte. The slave address byte consists of seven address bits and a direction bit that indicates whether the action is to be a read or write operation.

The INA230 has two address pins: A0 and A1. [Table 7](#) describes the pin logic levels for each of the 16 possible addresses. The state of pins A0 and A1 is sampled on every bus communication and should be set before any activity on the interface occurs.

**Table 7. INA230 Address Pins and Slave Addresses**

A1	A0	SLAVE ADDRESS
GND	GND	1000000
GND	V <sub>S</sub>	1000001
GND	SDA	1000010
GND	SCL	1000011
V <sub>S</sub>	GND	1000100
V <sub>S</sub>	V <sub>S</sub>	1000101
V <sub>S</sub>	SDA	1000110
V <sub>S</sub>	SCL	1000111
SDA	GND	1001000
SDA	V <sub>S</sub>	1001001
SDA	SDA	1001010
SDA	SCL	1001011
SCL	GND	1001100
SCL	V <sub>S</sub>	1001101
SCL	SDA	1001110
SCL	SCL	1001111

### Serial Interface

The INA230 operates only as a slave device on both the I<sup>2</sup>C bus and the SMBus. Connections to the bus are made through the open-drain I/O lines, SDA and SCL. The SDA and SCL pins feature integrated spike-suppression filters and Schmitt triggers to minimize the effects of input spikes and bus noise. Although there is spike suppression integrated into the digital I/O lines, proper layout should be used to minimize the amount of coupling into the communication lines. This noise introduction could occur from capacitively coupling signal edges between the two communication lines themselves or from other switching noise sources present in the system. Routing traces in parallel with ground in between layers on a printed circuit board (PCB) typically reduces the effects of coupling between the communication lines. Shielding communication lines in general is recommended to reduce to possibility of unintended noise coupling into the digital I/O lines that could be incorrectly interpreted as start or stop commands.

The INA230 supports the transmission protocol for Fast (1 kHz to 400 kHz) and High-speed (1 kHz to 3.4 MHz) modes. All data bytes are transmitted most significant byte first.

## WRITING TO/READING FROM THE INA230

Accessing a specific register on the INA230 is accomplished by writing the appropriate value to the register pointer. Refer to [Table 2](#) for a complete list of registers and corresponding addresses. The value for the register pointer (shown in [Figure 27](#)) is the first byte transferred after the slave address byte with the R/W bit low. Every write operation to the INA230 requires a value for the register pointer.

Writing to a register begins with the first byte transmitted by the master. This byte is the slave address, with the R/W bit low. The INA230 then acknowledges receipt of a valid address. The next byte transmitted by the master is the address of the register that data will be written to. This register address value updates the register pointer to the desired register. The next two bytes are written to the register addressed by the register pointer. The INA230 acknowledges receipt of each data byte. The master may terminate data transfer by generating a start or stop condition.

When reading from the INA230, the last value stored in the register pointer by a write operation determines which register is read during a read operation. To change the register pointer for a read operation, a new value must be written to the register pointer. This write is accomplished by issuing a slave address byte with the R/W bit low, followed by the register pointer byte. No additional data are required. The master then generates a start condition and sends the slave address byte with the R/W bit high to initiate the read command. The next byte is transmitted by the slave and is the most significant byte of the register indicated by the register pointer. This byte is followed by an ACK from the master; then the slave transmits the least significant byte. The master acknowledges receipt of the data byte. The master may terminate data transfer by generating a *Not-Acknowledge* bit (No ACK) after receiving any data byte, or generating a start or stop condition. If repeated reads from the same register are desired, it is not necessary to continually send the register pointer bytes; the INA230 retains the register pointer value until it is changed by the next write operation.

[Figure 24](#) and [Figure 25](#) show the write and read operation timing diagrams, respectively. Note that register bytes are sent most-significant byte first, followed by the least significant byte.

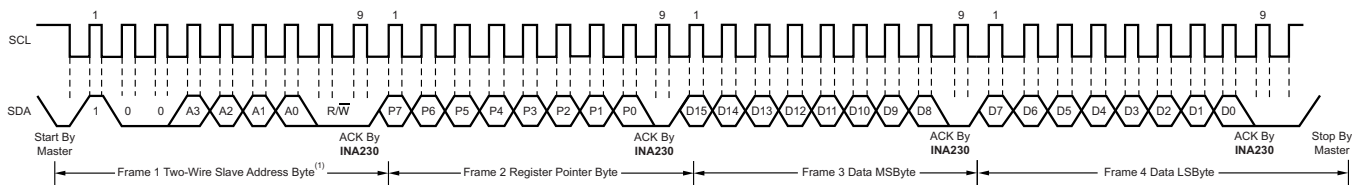

- (1) The value of the slave address byte is determined by the settings of the A0 and A1 pins. Refer to [Table 7](#).

**Figure 24. Timing Diagram for Write Word Format**

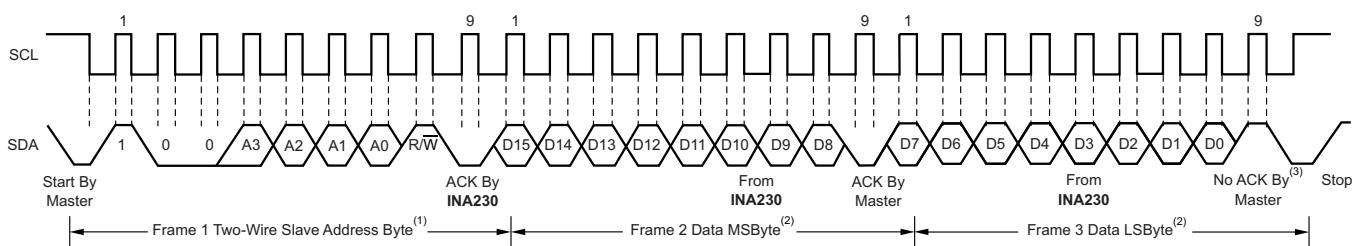

- (1) The value of the slave address byte is determined by the settings of the A0 and A1 pins. Refer to [Table 7](#).
- (2) Read data are from the last register pointer location. If a new register is desired, the register pointer must be updated. See [Figure 27](#).
- (3) ACK by Master can also be sent.

**Figure 25. Timing Diagram for Read Word Format**

Figure 26 shows the timing diagram for the SMBus alert response operation. Figure 27 illustrates a typical register pointer configuration.

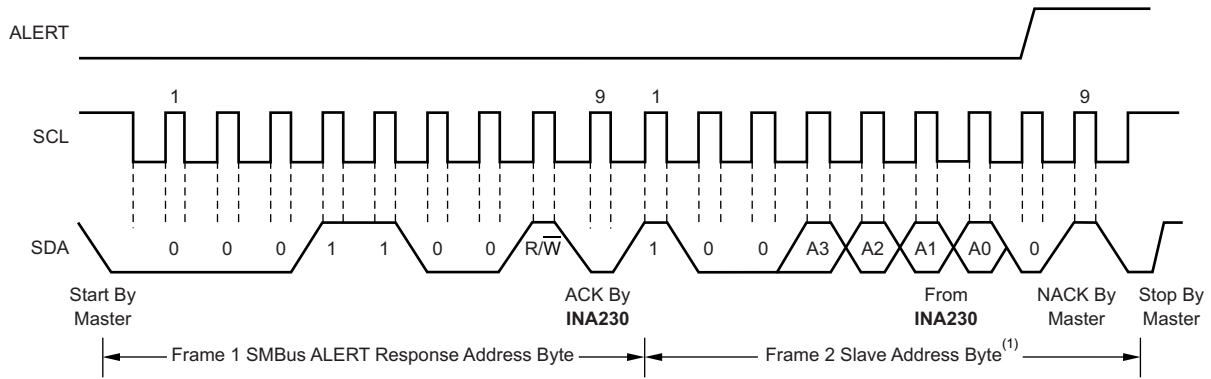

(1) The value of the slave address byte is determined by the settings of the A0 and A1 pins. Refer to Table 7.

**Figure 26. Timing Diagram for SMBus Alert**

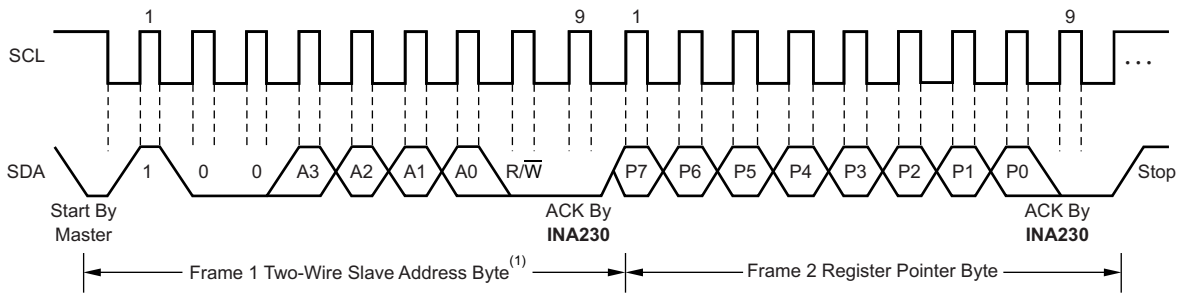

(1) The value of the slave address byte is determined by the settings of the A0 and A1 pins. Refer to Table 7.

**Figure 27. Typical Register Pointer Set**

## High-Speed I<sup>2</sup>C Mode

When the bus is idle, both the SDA and SCL lines are pulled high by the pull-up devices. The master generates a start condition followed by a valid serial byte containing High-Speed (HS) master code `00001XXX`. This transmission is made in fast (400 kHz) or standard (100 kHz) (F/S) mode at no more than 400 kHz. The INA230 does not acknowledge the HS master code, but does recognize it and switches its internal filters to support 3.4-MHz operation.

The master then generates a repeated start condition (a repeated start condition has the same timing as the start condition). After this repeated start condition, the protocol is the same as F/S mode, except that transmission speeds up to 3.4 MHz are allowed. Instead of using a stop condition, repeated start conditions should be used to secure the bus in HS-mode. A stop condition ends the HS-mode and switches all the internal filters of the INA230 to support the F/S mode.

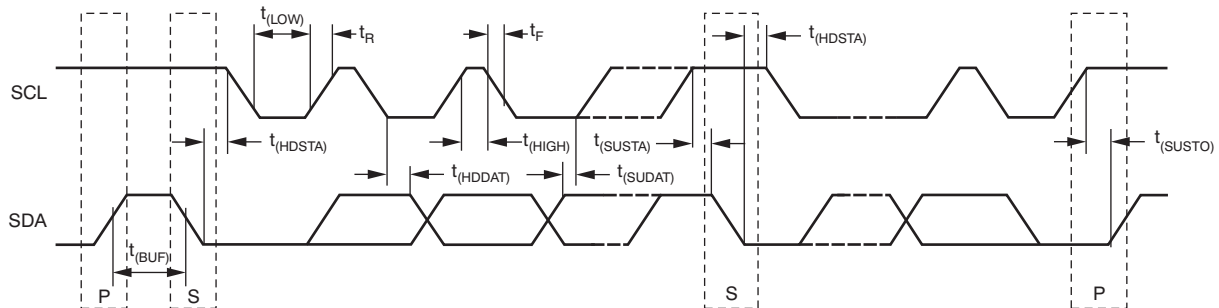

**Figure 28. Bus Timing Diagram**

### Bus Timing Diagram Definitions

PARAMETER		FAST MODE		HIGH-SPEED MODE		UNITS
		MIN	MAX	MIN	MAX	
SCL operating frequency	$f_{(SCL)}$	0.001	0.4	0.001	3.4	MHz
Bus free time between stop and start conditions	$t_{(BUF)}$	600		160		ns
Hold time after repeated START condition. After this period, the first clock is generated.	$t_{(HDSTA)}$	100		100		ns
Repeated start condition setup time	$t_{(SUSTA)}$	100		100		ns
STOP condition setup time	$t_{(SUSTO)}$	100		100		ns
Data hold time	$t_{(HDDAT)}$	0		0		ns
Data setup time	$t_{(SUDAT)}$	100		10		ns
SCL clock low period	$t_{(LOW)}$	1300		160		ns
SCL clock high period	$t_{(HIGH)}$	600		60		ns
Clock/data fall time	$t_F$		300		160	ns
Clock/data rise time	$t_R$		300		160	ns
Clock/data rise time for $SCLK \leq 100$ kHz	$t_R$		1000			ns

## SMBus Alert Response

The INA230 is designed to respond to the SMBus alert response address. The SMBus alert response provides a quick fault identification for simple slave devices. When an alert occurs, the master can broadcast the alert response slave address (0001 100) with the Read/Write bit set high. Following this alert response, any slave devices that generated an alert identify themselves by acknowledging the alert response and sending their respective address on the bus.

The alert response can activate several different slave devices simultaneously, similar to the I<sup>2</sup>C general call. If more than one slave attempts to respond, bus arbitration rules apply. The losing device does not generate an acknowledge and continues to hold the ALERT line low until the interrupt is cleared.

**PACKAGING INFORMATION**

Orderable Device	Status (1)	Package Type	Package Drawing	Pins	Package Qty	Eco Plan (2)	Lead/Ball Finish (6)	MSL Peak Temp (3)	Op Temp (°C)	Device Marking (4/5)	Samples
INA230AIRGTR	ACTIVE	VQFN	RGT	16	3000	Green (RoHS & no Sb/Br)	CU NIPDAU	Level-2-260C-1 YEAR	-40 to 125	I230	<a href="#">Samples</a>
INA230AIRGTT	ACTIVE	VQFN	RGT	16	250	Green (RoHS & no Sb/Br)	CU NIPDAU	Level-2-260C-1 YEAR	-40 to 125	I230	<a href="#">Samples</a>

(1) The marketing status values are defined as follows:

**ACTIVE:** Product device recommended for new designs.

**LIFEBUY:** TI has announced that the device will be discontinued, and a lifetime-buy period is in effect.

**NRND:** Not recommended for new designs. Device is in production to support existing customers, but TI does not recommend using this part in a new design.

**PREVIEW:** Device has been announced but is not in production. Samples may or may not be available.

**OBsolete:** TI has discontinued the production of the device.

(2) **RoHS:** TI defines "RoHS" to mean semiconductor products that are compliant with the current EU RoHS requirements for all 10 RoHS substances, including the requirement that RoHS substance do not exceed 0.1% by weight in homogeneous materials. Where designed to be soldered at high temperatures, "RoHS" products are suitable for use in specified lead-free processes. TI may reference these types of products as "Pb-Free".

**RoHS Exempt:** TI defines "RoHS Exempt" to mean products that contain lead but are compliant with EU RoHS pursuant to a specific EU RoHS exemption.

**Green:** TI defines "Green" to mean the content of Chlorine (Cl) and Bromine (Br) based flame retardants meet JS709B low halogen requirements of <=1000ppm threshold. Antimony trioxide based flame retardants must also meet the <=1000ppm threshold requirement.

(3) MSL, Peak Temp. - The Moisture Sensitivity Level rating according to the JEDEC industry standard classifications, and peak solder temperature.

(4) There may be additional marking, which relates to the logo, the lot trace code information, or the environmental category on the device.

(5) Multiple Device Markings will be inside parentheses. Only one Device Marking contained in parentheses and separated by a "~" will appear on a device. If a line is indented then it is a continuation of the previous line and the two combined represent the entire Device Marking for that device.

(6) Lead/Ball Finish - Orderable Devices may have multiple material finish options. Finish options are separated by a vertical ruled line. Lead/Ball Finish values may wrap to two lines if the finish value exceeds the maximum column width.

**Important Information and Disclaimer:**The information provided on this page represents TI's knowledge and belief as of the date that it is provided. TI bases its knowledge and belief on information provided by third parties, and makes no representation or warranty as to the accuracy of such information. Efforts are underway to better integrate information from third parties. TI has taken and continues to take reasonable steps to provide representative and accurate information but may not have conducted destructive testing or chemical analysis on incoming materials and chemicals. TI and TI suppliers consider certain information to be proprietary, and thus CAS numbers and other limited information may not be available for release.

In no event shall TI's liability arising out of such information exceed the total purchase price of the TI part(s) at issue in this document sold by TI to Customer on an annual basis.



## TAPE AND REEL INFORMATION



### QUADRANT ASSIGNMENTS FOR PIN 1 ORIENTATION IN TAPE



\*All dimensions are nominal

Device	Package Type	Package Drawing	Pins	SPQ	Reel Diameter (mm)	Reel Width W1 (mm)	A0 (mm)	B0 (mm)	K0 (mm)	P1 (mm)	W (mm)	Pin1 Quadrant
INA230AIRGTR	VQFN	RGT	16	3000	330.0	12.4	3.3	3.3	1.1	8.0	12.0	Q2
INA230AIRGTT	VQFN	RGT	16	250	180.0	12.4	3.3	3.3	1.1	8.0	12.0	Q2

**TAPE AND REEL BOX DIMENSIONS**

\*All dimensions are nominal

Device	Package Type	Package Drawing	Pins	SPQ	Length (mm)	Width (mm)	Height (mm)
INA230AIRGTR	VQFN	RGT	16	3000	367.0	367.0	35.0
INA230AIRGTT	VQFN	RGT	16	250	210.0	185.0	35.0

**RGT 16**

**GENERIC PACKAGE VIEW**

**VQFN - 1 mm max height**

PLASTIC QUAD FLATPACK - NO LEAD

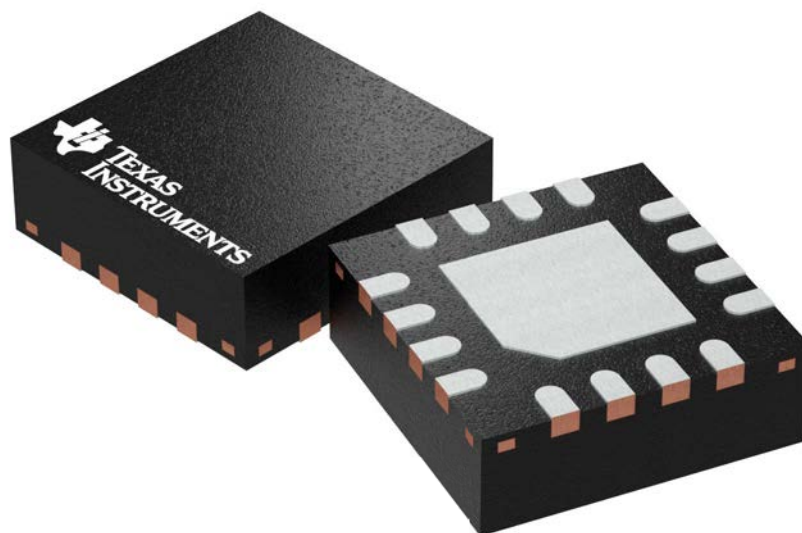

Images above are just a representation of the package family, actual package may vary.  
Refer to the product data sheet for package details.

4203495/1





# EXAMPLE STENCIL DESIGN

RGT0016C

VQFN - 1 mm max height

PLASTIC QUAD FLATPACK - NO LEAD

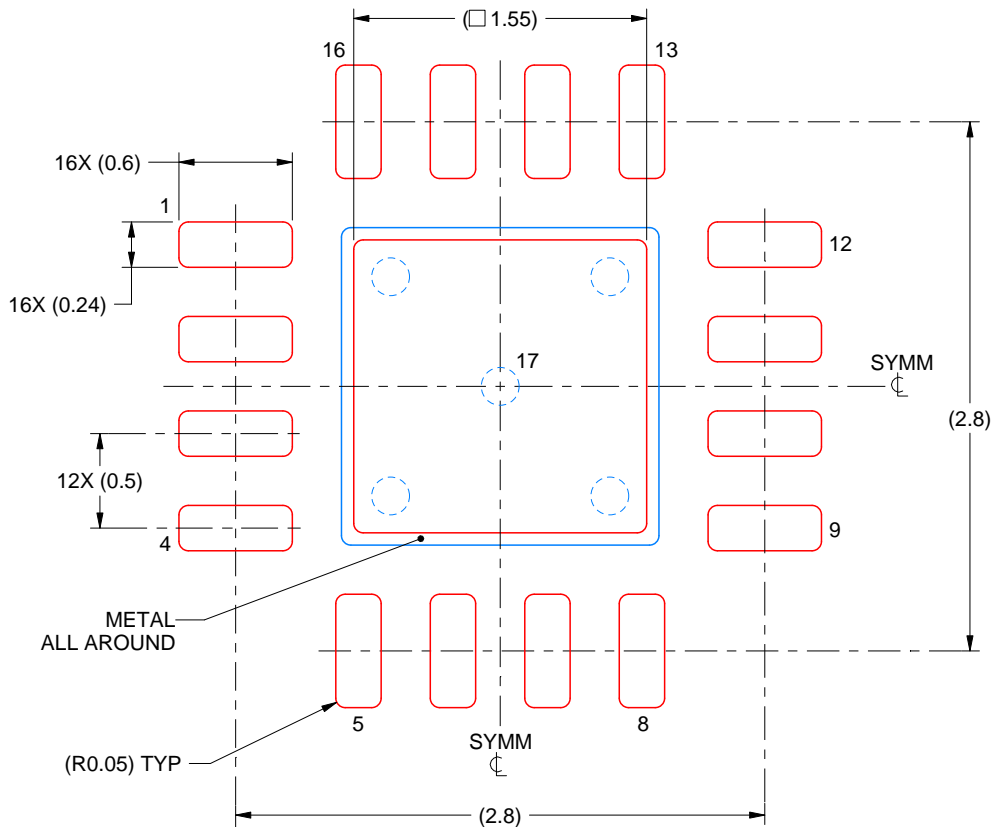

**SOLDER PASTE EXAMPLE**  
BASED ON 0.125 mm THICK STENCIL

EXPOSED PAD 17:  
85% PRINTED SOLDER COVERAGE BY AREA UNDER PACKAGE  
SCALE:25X

4222419/B 11/2016

NOTES: (continued)

6. Laser cutting apertures with trapezoidal walls and rounded corners may offer better paste release. IPC-7525 may have alternate design recommendations.

## IMPORTANT NOTICE

Texas Instruments Incorporated (TI) reserves the right to make corrections, enhancements, improvements and other changes to its semiconductor products and services per JESD46, latest issue, and to discontinue any product or service per JESD48, latest issue. Buyers should obtain the latest relevant information before placing orders and should verify that such information is current and complete.

TI's published terms of sale for semiconductor products (<http://www.ti.com/sc/docs/stdterms.htm>) apply to the sale of packaged integrated circuit products that TI has qualified and released to market. Additional terms may apply to the use or sale of other types of TI products and services.

Reproduction of significant portions of TI information in TI data sheets is permissible only if reproduction is without alteration and is accompanied by all associated warranties, conditions, limitations, and notices. TI is not responsible or liable for such reproduced documentation. Information of third parties may be subject to additional restrictions. Resale of TI products or services with statements different from or beyond the parameters stated by TI for that product or service voids all express and any implied warranties for the associated TI product or service and is an unfair and deceptive business practice. TI is not responsible or liable for any such statements.

Buyers and others who are developing systems that incorporate TI products (collectively, "Designers") understand and agree that Designers remain responsible for using their independent analysis, evaluation and judgment in designing their applications and that Designers have full and exclusive responsibility to assure the safety of Designers' applications and compliance of their applications (and of all TI products used in or for Designers' applications) with all applicable regulations, laws and other applicable requirements. Designer represents that, with respect to their applications, Designer has all the necessary expertise to create and implement safeguards that (1) anticipate dangerous consequences of failures, (2) monitor failures and their consequences, and (3) lessen the likelihood of failures that might cause harm and take appropriate actions. Designer agrees that prior to using or distributing any applications that include TI products, Designer will thoroughly test such applications and the functionality of such TI products as used in such applications.

TI's provision of technical, application or other design advice, quality characterization, reliability data or other services or information, including, but not limited to, reference designs and materials relating to evaluation modules, (collectively, "TI Resources") are intended to assist designers who are developing applications that incorporate TI products; by downloading, accessing or using TI Resources in any way, Designer (individually or, if Designer is acting on behalf of a company, Designer's company) agrees to use any particular TI Resource solely for this purpose and subject to the terms of this Notice.

TI's provision of TI Resources does not expand or otherwise alter TI's applicable published warranties or warranty disclaimers for TI products, and no additional obligations or liabilities arise from TI providing such TI Resources. TI reserves the right to make corrections, enhancements, improvements and other changes to its TI Resources. TI has not conducted any testing other than that specifically described in the published documentation for a particular TI Resource.

Designer is authorized to use, copy and modify any individual TI Resource only in connection with the development of applications that include the TI product(s) identified in such TI Resource. NO OTHER LICENSE, EXPRESS OR IMPLIED, BY ESTOPPEL OR OTHERWISE TO ANY OTHER TI INTELLECTUAL PROPERTY RIGHT, AND NO LICENSE TO ANY TECHNOLOGY OR INTELLECTUAL PROPERTY RIGHT OF TI OR ANY THIRD PARTY IS GRANTED HEREIN, including but not limited to any patent right, copyright, mask work right, or other intellectual property right relating to any combination, machine, or process in which TI products or services are used. Information regarding or referencing third-party products or services does not constitute a license to use such products or services, or a warranty or endorsement thereof. Use of TI Resources may require a license from a third party under the patents or other intellectual property of the third party, or a license from TI under the patents or other intellectual property of TI.

TI RESOURCES ARE PROVIDED "AS IS" AND WITH ALL FAULTS. TI DISCLAIMS ALL OTHER WARRANTIES OR REPRESENTATIONS, EXPRESS OR IMPLIED, REGARDING RESOURCES OR USE THEREOF, INCLUDING BUT NOT LIMITED TO ACCURACY OR COMPLETENESS, TITLE, ANY EPIDEMIC FAILURE WARRANTY AND ANY IMPLIED WARRANTIES OF MERCHANTABILITY, FITNESS FOR A PARTICULAR PURPOSE, AND NON-INFRINGEMENT OF ANY THIRD PARTY INTELLECTUAL PROPERTY RIGHTS. TI SHALL NOT BE LIABLE FOR AND SHALL NOT DEFEND OR INDEMNIFY DESIGNER AGAINST ANY CLAIM, INCLUDING BUT NOT LIMITED TO ANY INFRINGEMENT CLAIM THAT RELATES TO OR IS BASED ON ANY COMBINATION OF PRODUCTS EVEN IF DESCRIBED IN TI RESOURCES OR OTHERWISE. IN NO EVENT SHALL TI BE LIABLE FOR ANY ACTUAL, DIRECT, SPECIAL, COLLATERAL, INDIRECT, PUNITIVE, INCIDENTAL, CONSEQUENTIAL OR EXEMPLARY DAMAGES IN CONNECTION WITH OR ARISING OUT OF TI RESOURCES OR USE THEREOF, AND REGARDLESS OF WHETHER TI HAS BEEN ADVISED OF THE POSSIBILITY OF SUCH DAMAGES.

Unless TI has explicitly designated an individual product as meeting the requirements of a particular industry standard (e.g., ISO/TS 16949 and ISO 26262), TI is not responsible for any failure to meet such industry standard requirements.

Where TI specifically promotes products as facilitating functional safety or as compliant with industry functional safety standards, such products are intended to help enable customers to design and create their own applications that meet applicable functional safety standards and requirements. Using products in an application does not by itself establish any safety features in the application. Designers must ensure compliance with safety-related requirements and standards applicable to their applications. Designer may not use any TI products in life-critical medical equipment unless authorized officers of the parties have executed a special contract specifically governing such use. Life-critical medical equipment is medical equipment where failure of such equipment would cause serious bodily injury or death (e.g., life support, pacemakers, defibrillators, heart pumps, neurostimulators, and implantables). Such equipment includes, without limitation, all medical devices identified by the U.S. Food and Drug Administration as Class III devices and equivalent classifications outside the U.S.

TI may expressly designate certain products as completing a particular qualification (e.g., Q100, Military Grade, or Enhanced Product). Designers agree that it has the necessary expertise to select the product with the appropriate qualification designation for their applications and that proper product selection is at Designers' own risk. Designers are solely responsible for compliance with all legal and regulatory requirements in connection with such selection.

Designer will fully indemnify TI and its representatives against any damages, costs, losses, and/or liabilities arising out of Designer's non-compliance with the terms and provisions of this Notice.

## Looking for pricing, stock, or lifecycle information?

Click below to explore more details on WIN SOURCE:

 [View INA230AIRGTR on WIN SOURCE](#)

 [Texas Instruments](#) Information

## Optimize Your Supply Chain with WIN SOURCE Solutions

-  Global Sourcing Solution
-  Obsolete Management
-  Cost Control Management
-  Shortage Management
-  Alternative Solution
-  Excess Inventory Management