



# THE DATASHEET OF INA333AIDRGT



## INA333 Micro-Power (50µA), Zero-Drift, Rail-to-Rail Out Instrumentation Amplifier

### 1 Features

- Low Offset Voltage: 25 µV (Maximum),  $G \geq 100$
- Low Drift: 0.1 µV/°C,  $G \geq 100$
- Low Noise: 50 nV/√Hz,  $G \geq 100$
- High CMRR: 100 dB (Minimum),  $G \geq 10$
- Low Input Bias Current: 200 pA (Maximum)
- Supply Range: 1.8 V to 5.5 V
- Input Voltage: (V–) +0.1 V to (V+) –0.1 V
- Output Range: (V–) +0.05 V to (V+) –0.05 V
- Low Quiescent Current: 50 µA
- Operating Temperature: –40°C to +125°C
- RFI Filtered Inputs
- 8-Pin VSSOP and 8-Pin WSON Packages

### 2 Applications

- Bridge Amplifiers
- ECG Amplifiers
- Pressure Sensors
- Medical Instrumentation
- Portable Instrumentation
- Weigh Scales
- Thermocouple Amplifiers
- RTD Sensor Amplifiers
- Data Acquisition

### 3 Description

The INA333 device is a low-power, precision instrumentation amplifier offering excellent accuracy. The versatile 3-operational amplifier design, small size, and low power make it ideal for a wide range of portable applications.

A single external resistor sets any gain from 1 to 1000. The INA333 is designed to use an industry-standard gain equation:  $G = 1 + (100 \text{ k}\Omega / R_G)$ .

The INA333 device provides very low offset voltage (25 µV,  $G \geq 100$ ), excellent offset voltage drift (0.1 µV/°C,  $G \geq 100$ ), and high common-mode rejection (100 dB at  $G \geq 10$ ). It operates with power supplies as low as 1.8 V ( $\pm 0.9$  V) and quiescent current is only 50 µA, making it ideal for battery-operated systems. Using autocalibration techniques to ensure excellent precision over the extended industrial temperature range, the INA333 device also offers exceptionally low noise density (50 nV/√Hz) that extends down to DC.

The INA333 device is available in both 8-pin VSSOP and WSON surface-mount packages and is specified over the  $T_A = -40^\circ\text{C}$  to  $+125^\circ\text{C}$  temperature range.

#### Device Information<sup>(1)</sup>

PART NUMBER	PACKAGE	BODY SIZE (NOM)
INA333	VSSOP (8)	3.00 mm x 3.00 mm
	WSON (8)	3.00 mm x 3.00 mm

(1) For all available packages, see the orderable addendum at the end of the data sheet.

#### Simplified Schematic

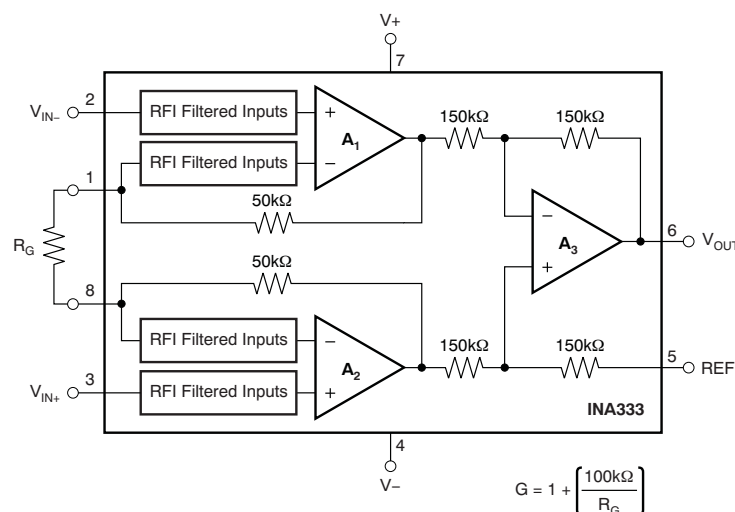

## Table of Contents

<b>1 Features</b> .....	<b>1</b>	7.4 Device Functional Modes.....	<b>13</b>
<b>2 Applications</b> .....	<b>1</b>	<b>8 Application and Implementation</b> .....	<b>14</b>
<b>3 Description</b> .....	<b>1</b>	8.1 Application Information.....	<b>14</b>
<b>4 Revision History</b> .....	<b>2</b>	8.2 Typical Application .....	<b>14</b>
<b>5 Pin Configuration and Functions</b> .....	<b>3</b>	<b>9 Power Supply Recommendations</b> .....	<b>19</b>
<b>6 Specifications</b> .....	<b>4</b>	<b>10 Layout</b> .....	<b>20</b>
6.1 Absolute Maximum Ratings .....	4	10.1 Layout Guidelines .....	20
6.2 ESD Ratings.....	4	10.2 Layout Example .....	20
6.3 Recommended Operating Conditions.....	4	<b>11 Device and Documentation Support</b> .....	<b>21</b>
6.4 Thermal Information .....	4	11.1 Device Support.....	21
6.5 Electrical Characteristics.....	5	11.2 Documentation Support .....	22
6.6 Typical Characteristics.....	7	11.3 Trademarks .....	22
<b>7 Detailed Description</b> .....	<b>13</b>	11.4 Electrostatic Discharge Caution.....	22
7.1 Overview .....	13	11.5 Glossary .....	23
7.2 Functional Block Diagram .....	13	<b>12 Mechanical, Packaging, and Orderable</b>	
7.3 Feature Description.....	13	<b>Information</b> .....	<b>23</b>

## 4 Revision History

NOTE: Page numbers for previous revisions may differ from page numbers in the current version.

### Changes from Revision B (October 2008) to Revision C

Page

- Added *ESD Ratings* table, *Feature Description* section, *Device Functional Modes*, *Application and Implementation* section, *Power Supply Recommendations* section, *Layout* section, *Device and Documentation Support* section, and *Mechanical, Packaging, and Orderable Information* section ..... **1**

## 5 Pin Configuration and Functions

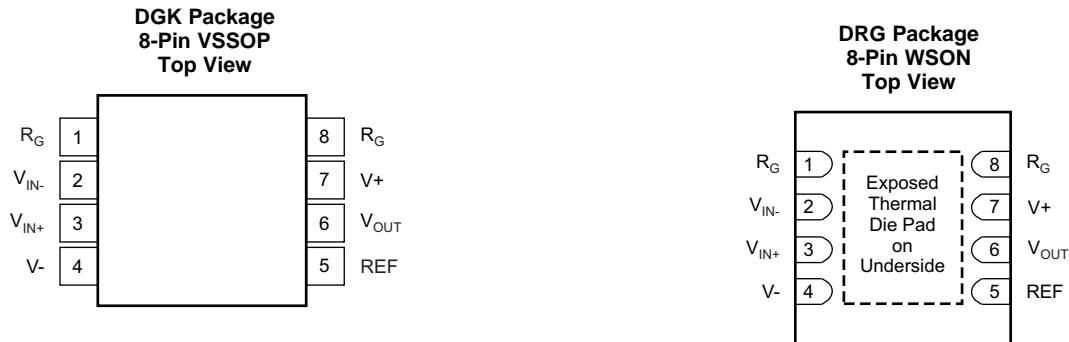

### Pin Functions

PIN		I/O	DESCRIPTION
NAME	NO.		
REF	5	I	Reference input. This pin must be driven by low impedance or connected to ground.
RG	1, 8	—	Gain setting pins. For gains greater than 1, place a gain resistor between pins 1 and 8.
V <sup>+</sup>	7	—	Positive supply
V <sup>-</sup>	4	—	Negative supply
V <sub>IN+</sub>	3	I	Positive input
V <sub>IN-</sub>	2	I	Negative input
V <sub>OUT</sub>	6	O	Output

## 6 Specifications

### 6.1 Absolute Maximum Ratings

over operating free-air temperature range (unless otherwise noted) <sup>(1)</sup>

	MIN	MAX	UNIT
Supply voltage	7		V
Analog input voltage <sup>(2)</sup>	(V <sub>-</sub> ) - 0.3	(V <sub>+</sub> ) + 0.3	V
Output short-circuit <sup>(3)</sup>	Continuous		
Operating temperature, T <sub>A</sub>	-40	150	°C
Junction temperature, T <sub>J</sub>		150	°C
Storage temperature, T <sub>stg</sub>	-65	150	°C

- (1) Stresses beyond those listed under *Absolute Maximum Ratings* may cause permanent damage to the device. These are stress ratings only, which do not imply functional operation of the device at these or any other conditions beyond those indicated under *Recommended Operating Conditions*. Exposure to absolute-maximum-rated conditions for extended periods may affect device reliability.
- (2) Input pins are diode-clamped to the power-supply rails. Input signals that can swing more than 0.3 V beyond the supply rails should be current limited to 10 mA or less.
- (3) Short-circuit to ground.

### 6.2 ESD Ratings

		VALUE	UNIT
V <sub>(ESD)</sub> Electrostatic discharge	Human-body model (HBM), per ANSI/ESDA/JEDEC JS-001 <sup>(1)</sup>	±4000	V
	Charged-device model (CDM), per JEDEC specification JESD22-C101 <sup>(2)</sup>	±1000	
	Machine model (MM)	±200	

- (1) JEDEC document JEP155 states that 500-V HBM allows safe manufacturing with a standard ESD control process.
- (2) JEDEC document JEP157 states that 250-V CDM allows safe manufacturing with a standard ESD control process.

### 6.3 Recommended Operating Conditions

over operating free-air temperature range (unless otherwise noted)

		MIN	MAX	UNIT
V <sub>S</sub>	Supply voltage	1.8	5.5	V
	Specified temperature	-40	125	°C

### 6.4 Thermal Information

THERMAL METRIC <sup>(1)</sup>		INA333		UNIT
		DGK (VSSOP)	DRG (WSON)	
		8 PINS	8 PINS	
R <sub>θJA</sub>	Junction-to-ambient thermal resistance	169.5	60	°C/W
R <sub>θJC(top)</sub>	Junction-to-case (top) thermal resistance	62.7	60	°C/W
R <sub>θJB</sub>	Junction-to-board thermal resistance	90.3	50	°C/W
ψ <sub>JT</sub>	Junction-to-top characterization parameter	7.6	—	°C/W
ψ <sub>JB</sub>	Junction-to-board characterization parameter	88.7	—	°C/W
R <sub>θJC(bot)</sub>	Junction-to-case (bottom) thermal resistance	—	6	°C/W

- (1) For more information about traditional and new thermal metrics, see the *Semiconductor and IC Package Thermal Metrics* application report, [SPRA953](#).

## 6.5 Electrical Characteristics

for  $V_S = 1.8\text{ V to }5.5\text{ V}$  at  $T_A = 25^\circ\text{C}$ ,  $R_L = 10\text{ k}\Omega$ ,  $V_{REF} = V_S / 2$ , and  $G = 1$  (unless otherwise noted)

PARAMETER		TEST CONDITIONS	MIN	TYP	MAX	UNIT
<b>INPUT<sup>(1)</sup></b>						
$V_{OSI}$	Offset voltage, RTI <sup>(2)</sup>			$\pm 10 \pm 25/G$	$\pm 25 \pm 75/G$	$\mu\text{V}$
	vs temperature	$T_A = -40^\circ\text{C to }+125^\circ\text{C}$			$\pm 0.1 \pm 0.5 / G$	$\mu\text{V}/^\circ\text{C}$
PSR	vs power supply	$1.8\text{ V} \leq V_S \leq 5.5\text{ V}$		$\pm 1 \pm 5/G$	$\pm 5 \pm 15/G$	$\mu\text{V}/\text{V}$
	Long-term stability			See <sup>(3)</sup>		
	Turnon time to specified $V_{OSI}$	$T_A = -40^\circ\text{C to }+125^\circ\text{C}$		See <a href="#">Typical Characteristics</a>		
	Impedance					
$Z_{IN}$	Differential			100    3		$\text{G}\Omega \parallel \text{pF}$
$Z_{IN}$	Common-mode			100    3		$\text{G}\Omega \parallel \text{pF}$
$V_{CM}$	Common-mode voltage range	$V_O = 0\text{ V}$	$(V-) + 0.1$		$(V+) - 0.1$	V
CMR	Common-mode rejection	DC to 60 Hz				
	$G = 1$	$V_{CM} = (V-) + 0.1\text{ V}$ to $(V+) - 0.1\text{ V}$	80	90		dB
	$G = 10$	$V_{CM} = (V-) + 0.1\text{ V}$ to $(V+) - 0.1\text{ V}$	100	110		dB
	$G = 100$	$V_{CM} = (V-) + 0.1\text{ V}$ to $(V+) - 0.1\text{ V}$	100	115		dB
	$G = 1000$	$V_{CM} = (V-) + 0.1\text{ V}$ to $(V+) - 0.1\text{ V}$	100	115		dB
<b>INPUT BIAS CURRENT</b>						
$I_B$	Input bias current			$\pm 70$	$\pm 200$	pA
	vs temperature	$T_A = -40^\circ\text{C to }+125^\circ\text{C}$		See <a href="#">Figure 26</a>		$\text{pA}/^\circ\text{C}$
$I_{OS}$	Input offset current			$\pm 50$	$\pm 200$	pA
	vs temperature	$T_A = -40^\circ\text{C to }+125^\circ\text{C}$		See <a href="#">Figure 28</a>		$\text{pA}/^\circ\text{C}$
<b>INPUT VOLTAGE NOISE</b>						
$e_{NI}$	Input voltage noise	$G = 100, R_S = 0\ \Omega, f = 10\text{ Hz}$		50		$\text{nV}/\sqrt{\text{Hz}}$
		$G = 100, R_S = 0\ \Omega, f = 100\text{ Hz}$		50		$\text{nV}/\sqrt{\text{Hz}}$
		$G = 100, R_S = 0\ \Omega, f = 1\text{ kHz}$		50		$\text{nV}/\sqrt{\text{Hz}}$
		$G = 100, R_S = 0\ \Omega, f = 0.1\text{ Hz to }10\text{ Hz}$		1		$\mu\text{V}_{PP}$
$i_N$	Input current noise	$f = 10\text{ Hz}$		100		$\text{fA}/\sqrt{\text{Hz}}$
		$f = 0.1\text{ Hz to }10\text{ Hz}$		2		$\text{pA}_{PP}$
<b>GAIN</b>						
G	Gain equation			$1 + (100\text{ k}\Omega/R_G)$		V/V
	Range of gain		1		1000	V/V
Gain error		$V_S = 5.5\text{ V}, (V-) + 100\text{ mV}$ $\leq V_O \leq (V+) - 100\text{ mV}$				
		$G = 1$		$\pm 0.01\%$	$\pm 0.1\%$	
		$G = 10$		$\pm 0.05\%$	$\pm 0.25\%$	
		$G = 100$		$\pm 0.07\%$	$\pm 0.25\%$	
	$G = 1000$		$\pm 0.25\%$	$\pm 0.5\%$		
	Gain vs temperature, $G = 1$	$T_A = -40^\circ\text{C to }+125^\circ\text{C}$		$\pm 1$	$\pm 5$	$\text{ppm}/^\circ\text{C}$
	Gain vs temperature, $G > 1$ <sup>(4)</sup>	$T_A = -40^\circ\text{C to }+125^\circ\text{C}$		$\pm 15$	$\pm 50$	$\text{ppm}/^\circ\text{C}$
Gain nonlinearity		$V_S = 5.5\text{ V}, (V-) + 100\text{ mV}$ $\leq V_O \leq (V+) - 100\text{ mV}$				
		$R_L = 10\text{ k}\Omega$		10		ppm
<b>OUTPUT</b>						
	Output voltage swing from rail	$V_S = 5.5\text{ V}, R_L = 10\text{ k}\Omega$		See <a href="#">Figure 29</a>		50 mV
	Capacitive load drive			500		pF
$I_{SC}$	Short-circuit current	Continuous to common		-40, +5		mA

(1) Total  $V_{OS}$ , referred-to-input =  $(V_{OSI}) + (V_{OSO} / G)$ 

(2) RTI = Referred-to-input

(3) 300-hour life test at  $150^\circ\text{C}$  demonstrated randomly distributed variation of approximately  $1\ \mu\text{V}$ 

(4) Does not include effects of external resistor  $R_G$

**Electrical Characteristics (continued)**

 for  $V_S = 1.8\text{ V}$  to  $5.5\text{ V}$  at  $T_A = 25^\circ\text{C}$ ,  $R_L = 10\text{ k}\Omega$ ,  $V_{REF} = V_S / 2$ , and  $G = 1$  (unless otherwise noted)

PARAMETER		TEST CONDITIONS	MIN	TYP	MAX	UNIT
<b>FREQUENCY RESPONSE</b>						
Bandwidth, -3dB		$G = 1$		150		kHz
		$G = 10$		35		kHz
		$G = 100$		3.5		kHz
		$G = 1000$		350		Hz
SR	Slew rate	$V_S = 5\text{ V}$ , $V_O = 4\text{-V step}$ , $G = 1$		0.16		V/ $\mu\text{s}$
		$V_S = 5\text{ V}$ , $V_O = 4\text{-V step}$ , $G = 100$		0.05		V/ $\mu\text{s}$
$t_S$	Settling time to 0.01%	$V_{STEP} = 4\text{ V}$ , $G = 1$		50		$\mu\text{s}$
		$V_{STEP} = 4\text{ V}$ , $G = 100$		400		$\mu\text{s}$
$t_S$	Settling time to 0.001%	$V_{STEP} = 4\text{ V}$ , $G = 1$		60		$\mu\text{s}$
		$V_{STEP} = 4\text{ V}$ , $G = 100$		500		$\mu\text{s}$
	Overload recovery	50% overdrive		75		$\mu\text{s}$
<b>REFERENCE INPUT</b>						
	$R_{IN}$			300		k $\Omega$
	Voltage range		V-		V+	V
<b>POWER SUPPLY</b>						
Voltage range	Single voltage range		+1.8		+5.5	V
	Dual voltage range		$\pm 0.9$		$\pm 2.75$	V
$I_Q$	Quiescent current	$V_{IN} = V_S / 2$		50	75	$\mu\text{A}$
	vs temperature	$T_A = -40^\circ\text{C}$ to $+125^\circ\text{C}$			80	$\mu\text{A}$
<b>TEMPERATURE RANGE</b>						
	Specified temperature range		-40		125	$^\circ\text{C}$
	Operating temperature range		-40		150	$^\circ\text{C}$

### 6.6 Typical Characteristics

at  $T_A = 25^\circ\text{C}$ ,  $V_S = 5\text{ V}$ ,  $R_L = 10\text{ k}\Omega$ ,  $V_{REF} = \text{midsupply}$ , and  $G = 1$  (unless otherwise noted)

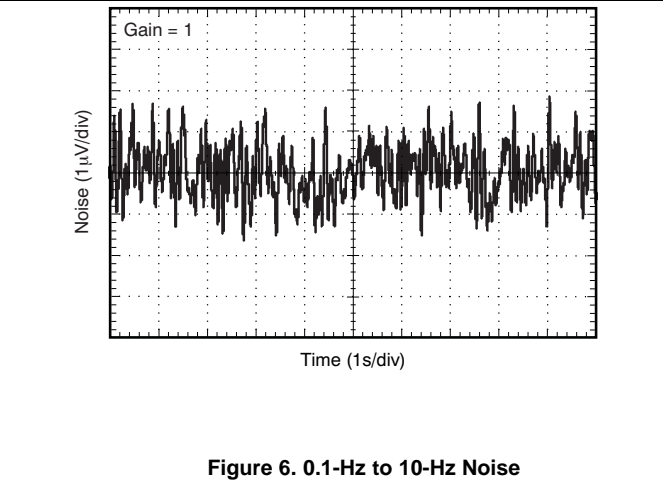
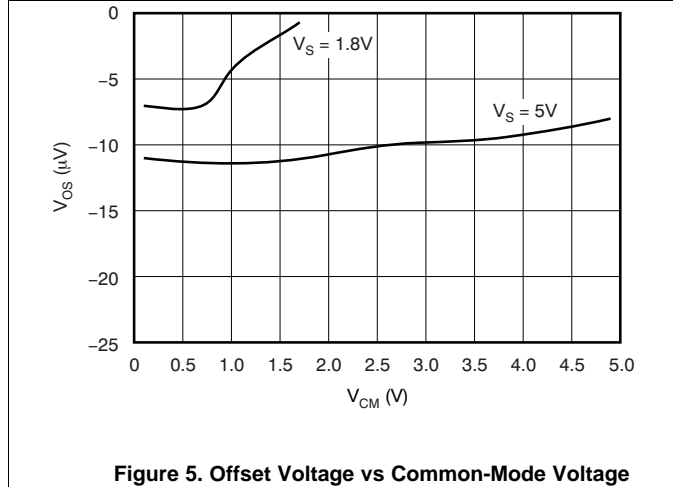
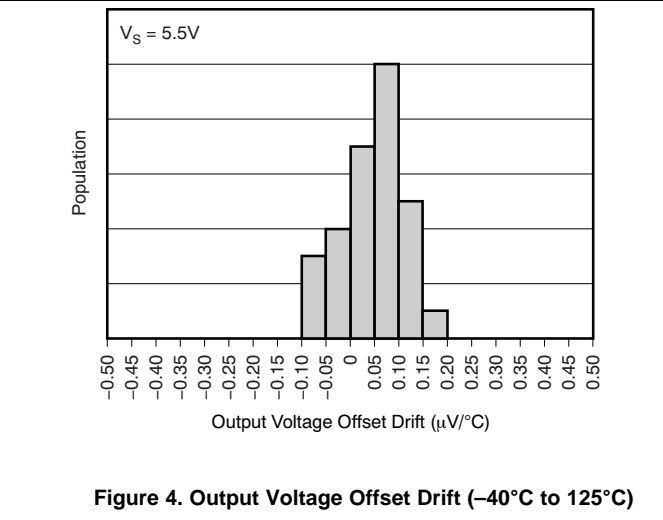
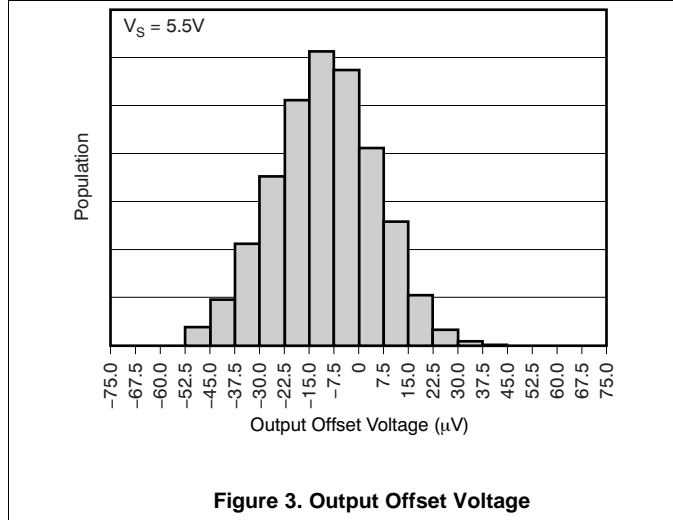
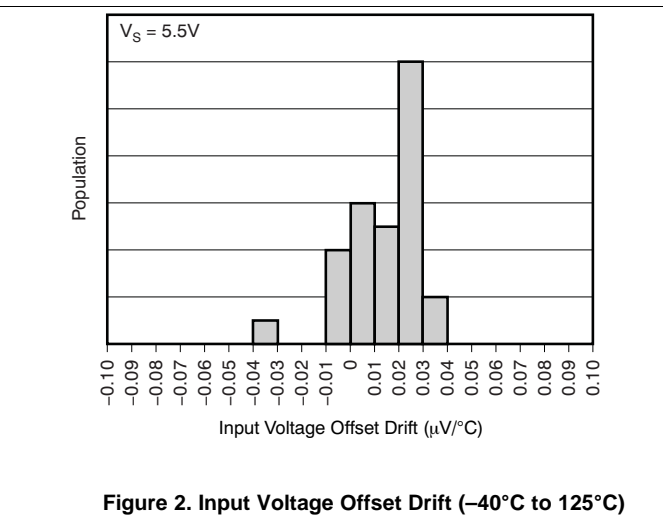
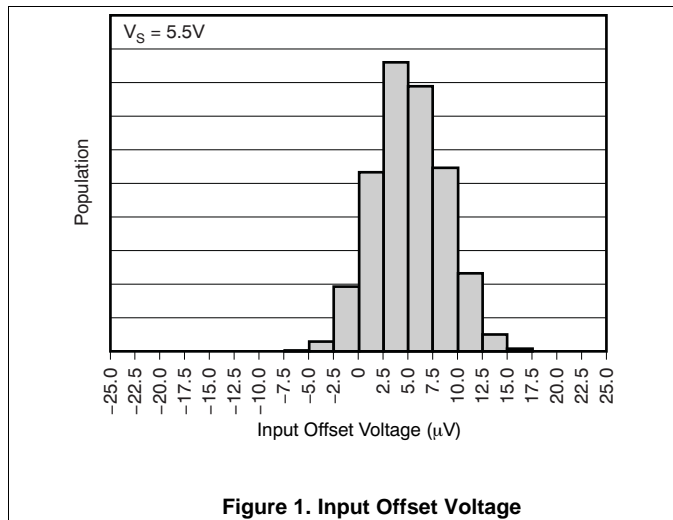

### Typical Characteristics (continued)

at  $T_A = 25^\circ\text{C}$ ,  $V_S = 5\text{ V}$ ,  $R_L = 10\text{ k}\Omega$ ,  $V_{REF} = \text{midsupply}$ , and  $G = 1$  (unless otherwise noted)

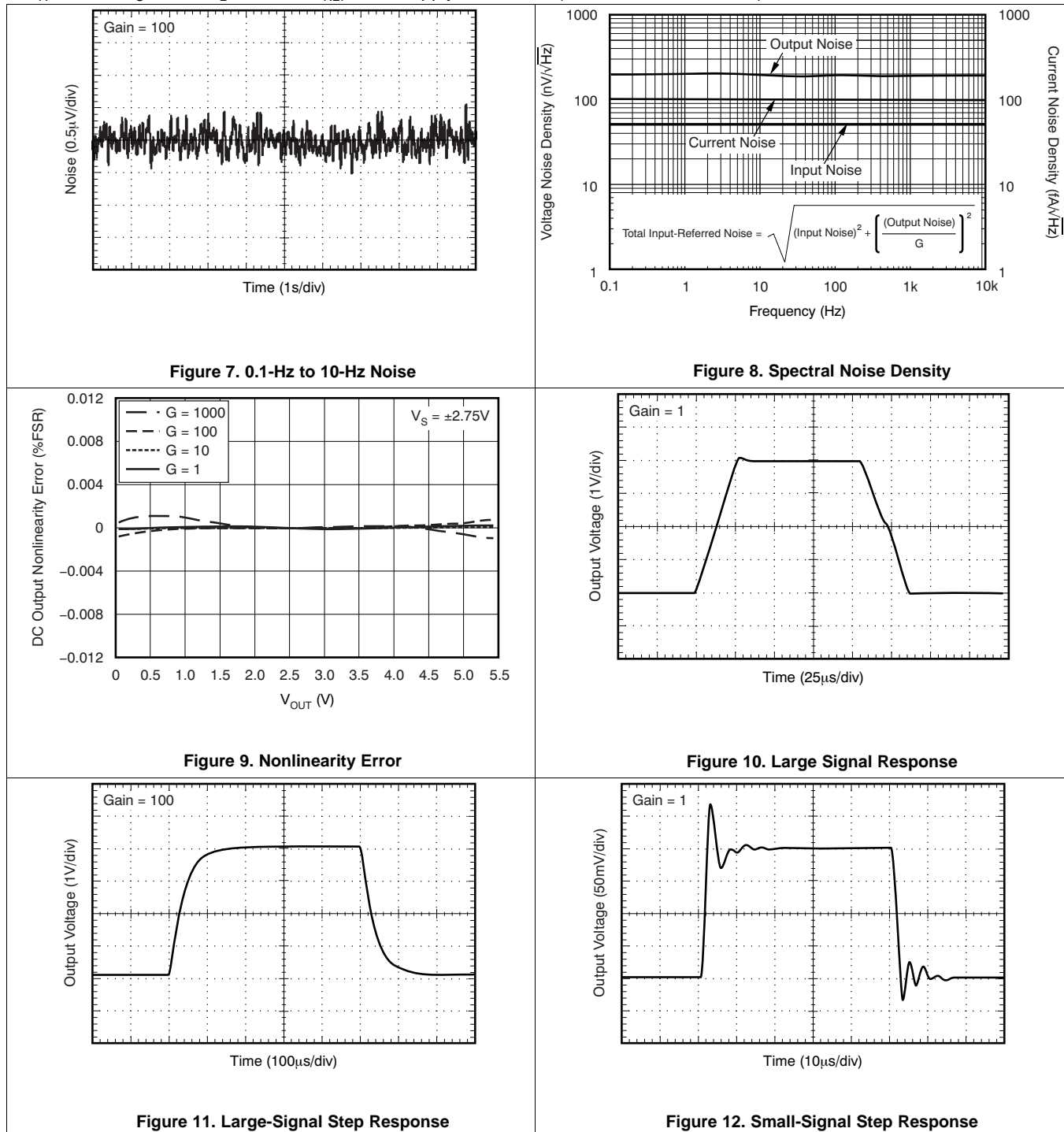

Typical Characteristics (continued)

at  $T_A = 25^\circ\text{C}$ ,  $V_S = 5\text{ V}$ ,  $R_L = 10\text{ k}\Omega$ ,  $V_{REF} = \text{mid supply}$ , and  $G = 1$  (unless otherwise noted)

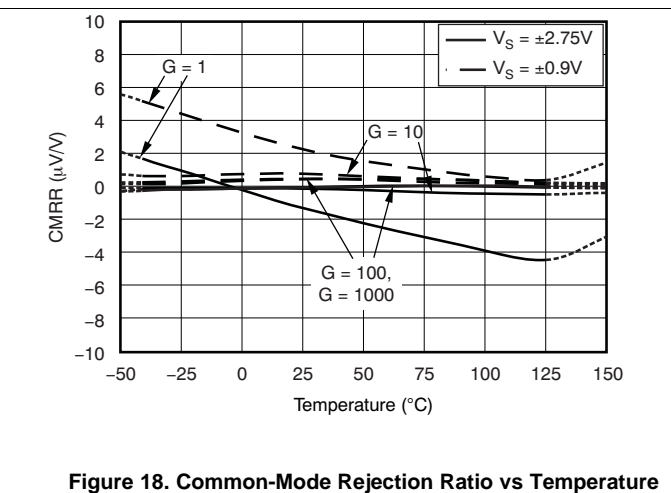
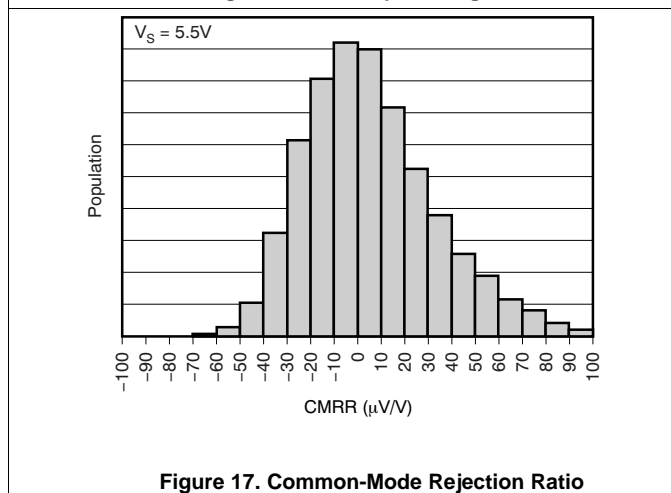
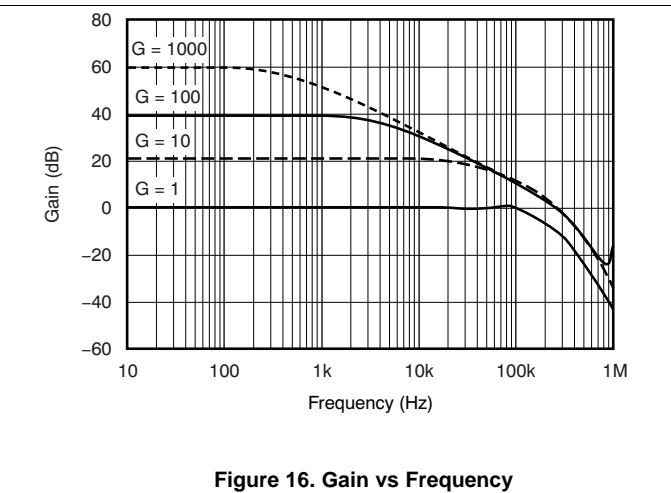
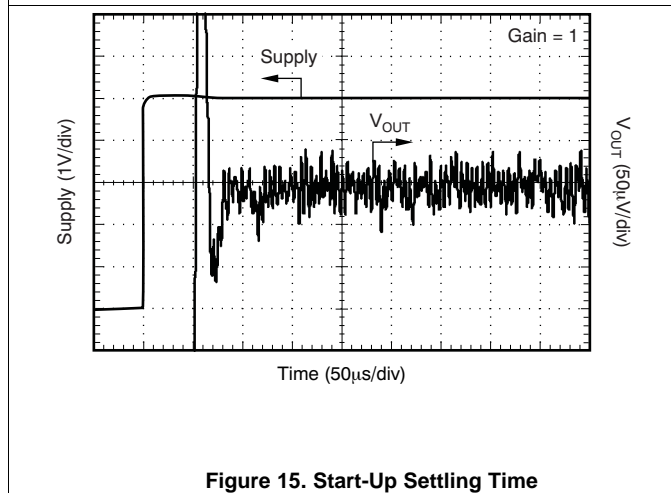
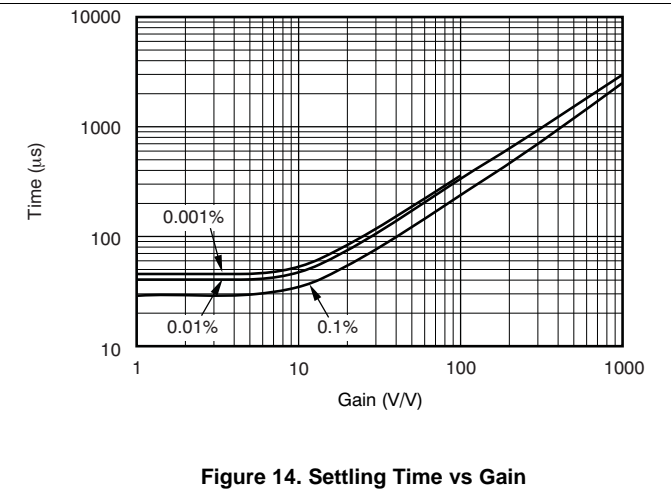
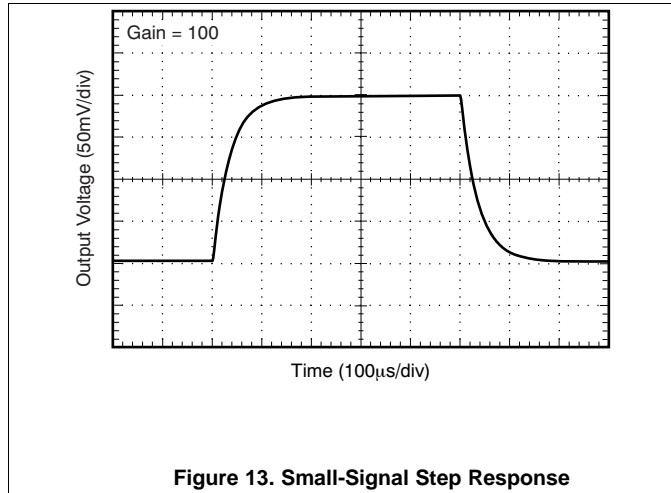

### Typical Characteristics (continued)

at  $T_A = 25^\circ\text{C}$ ,  $V_S = 5\text{ V}$ ,  $R_L = 10\text{ k}\Omega$ ,  $V_{REF} = \text{mid supply}$ , and  $G = 1$  (unless otherwise noted)

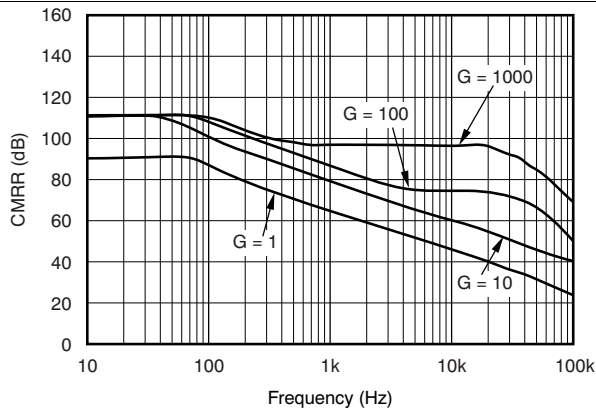

Figure 19. Common-Mode Rejection Ratio vs Frequency

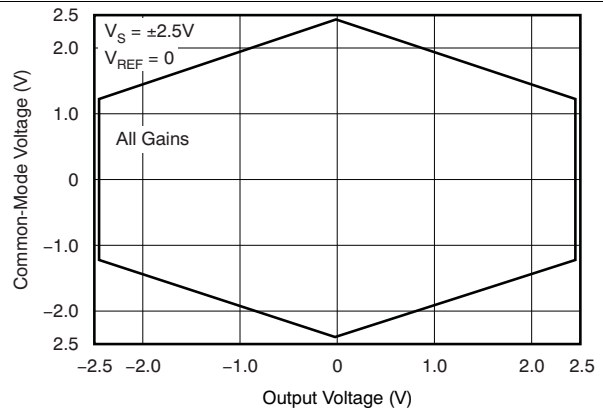

Figure 20. Typical Common-Mode Range vs Output Voltage

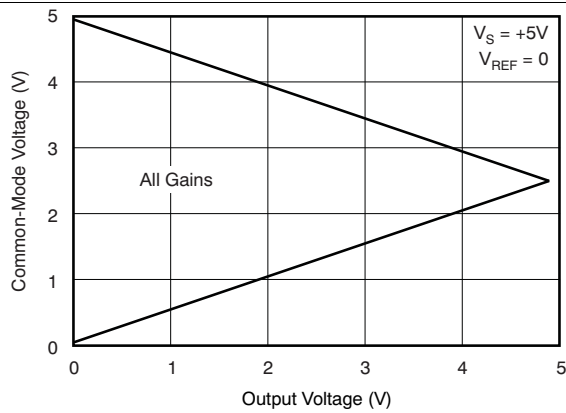

Figure 21. Typical Common-Mode Range vs Output Voltage

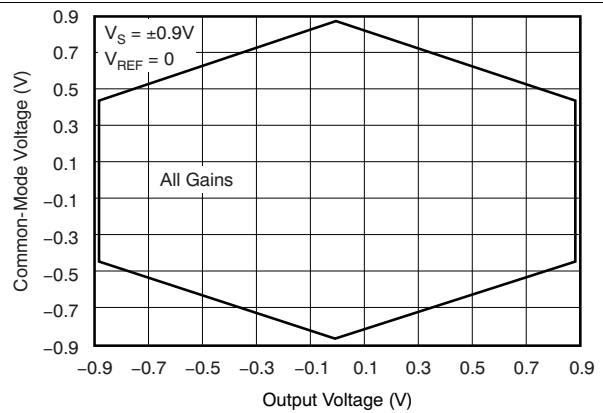

Figure 22. Typical Common-Mode Range vs Output Voltage

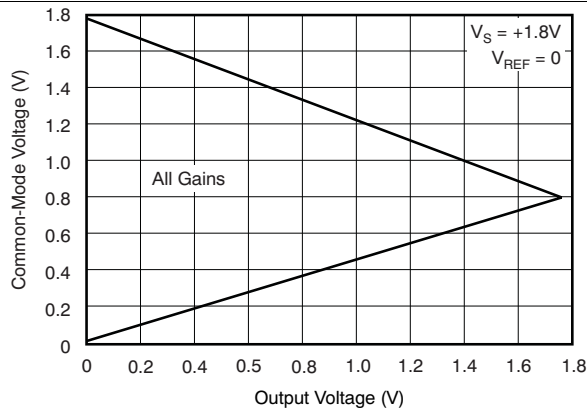

Figure 23. Typical Common-Mode Range vs Output Voltage

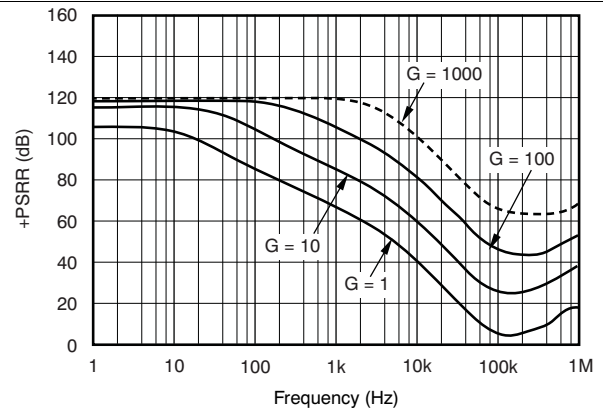

Figure 24. Positive Power-Supply Rejection Ratio

Typical Characteristics (continued)

at  $T_A = 25^\circ\text{C}$ ,  $V_S = 5\text{ V}$ ,  $R_L = 10\text{ k}\Omega$ ,  $V_{REF} = \text{mid supply}$ , and  $G = 1$  (unless otherwise noted)

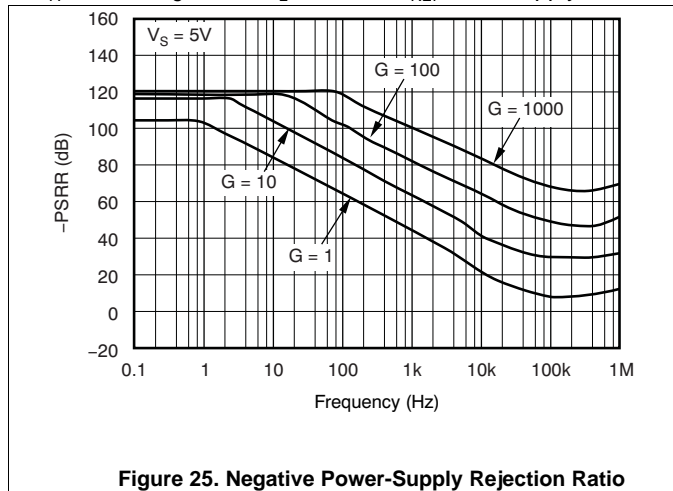

Figure 25. Negative Power-Supply Rejection Ratio

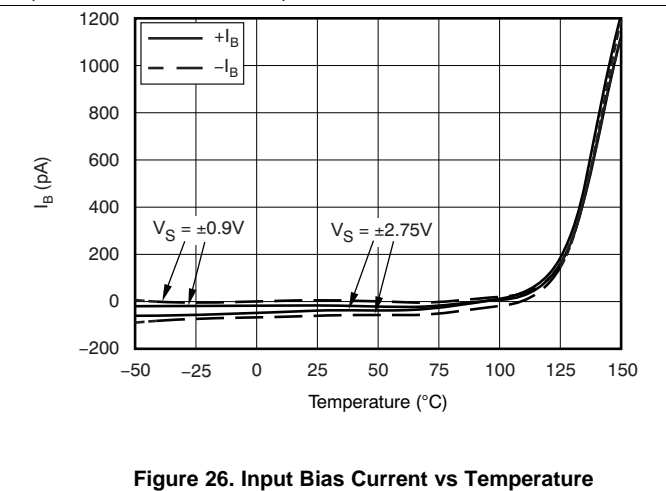

Figure 26. Input Bias Current vs Temperature

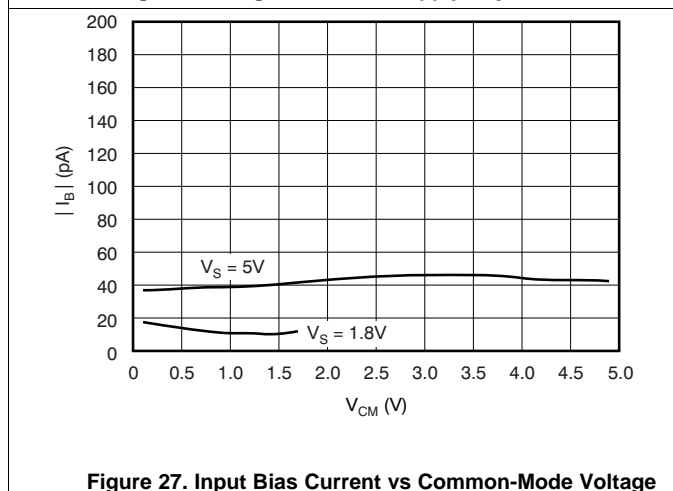

Figure 27. Input Bias Current vs Common-Mode Voltage

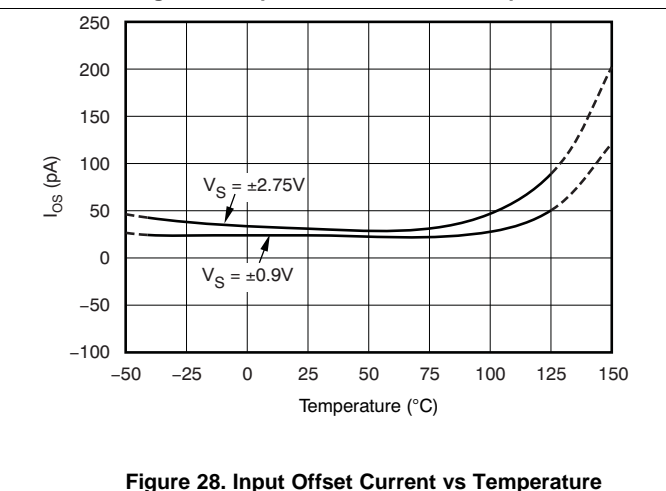

Figure 28. Input Offset Current vs Temperature

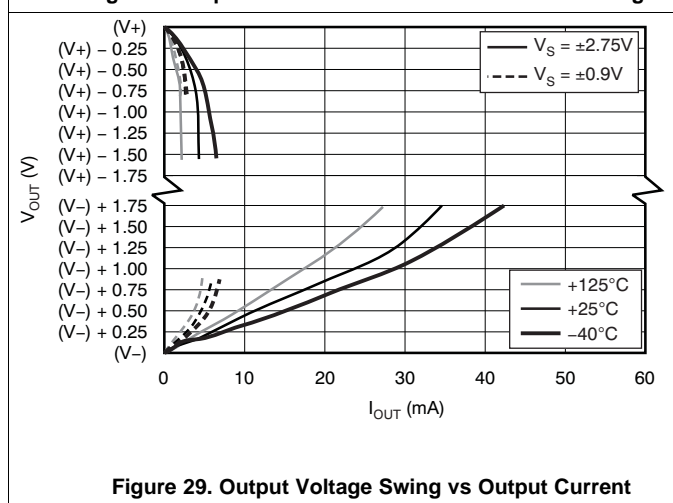

Figure 29. Output Voltage Swing vs Output Current

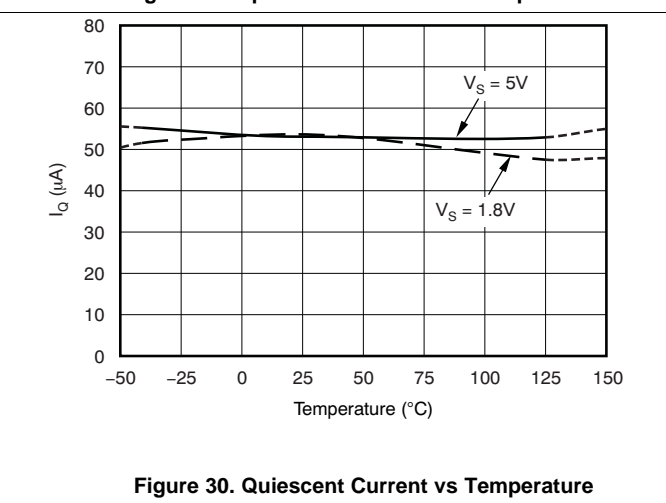
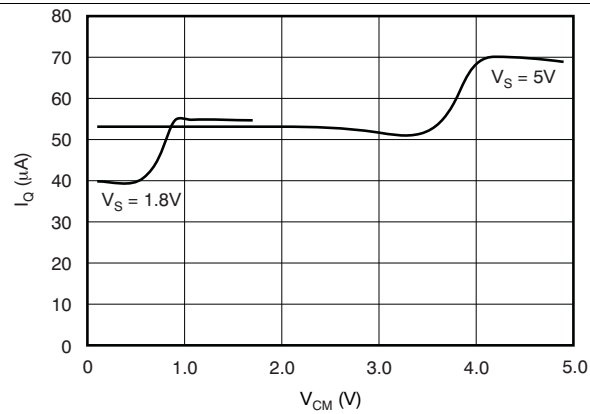

Figure 30. Quiescent Current vs Temperature

**Typical Characteristics (continued)**

at  $T_A = 25^\circ\text{C}$ ,  $V_S = 5\text{ V}$ ,  $R_L = 10\text{ k}\Omega$ ,  $V_{REF} = \text{midsupply}$ , and  $G = 1$  (unless otherwise noted)



**Figure 31. Quiescent Current vs Common-Mode Voltage**

## 7 Detailed Description

### 7.1 Overview

The INA333 is a monolithic instrumentation amplifier (INA) based on the precision zero-drift OPA333 (operational amplifier) core. The INA333 also integrates laser-trimmed resistors to ensure excellent common-mode rejection and low gain error. The combination of the zero-drift amplifier core and the precision resistors allows this device to achieve outstanding DC precision and makes the INA333 ideal for many 3.3-V and 5-V industrial applications.

### 7.2 Functional Block Diagram

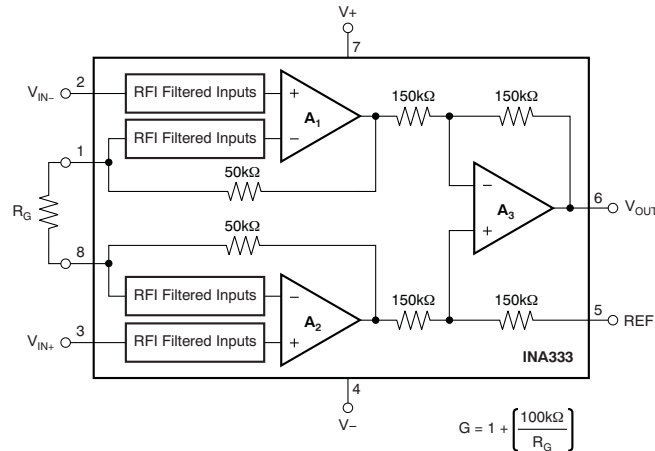

### 7.3 Feature Description

The INA333 is a low-power, zero-drift instrumentation amplifier offering excellent accuracy. The versatile three-operational-amplifier design and small size make the amplifiers ideal for a wide range of applications. Zero-drift chopper circuitry provides excellent DC specifications. A single external resistor sets any gain from 1 to 10,000. The INA333 is laser trimmed for very high common-mode rejection (100 dB at  $G \geq 100$ ). This devices operate with power supplies as low as 1.8 V, and quiescent current of 50  $\mu\text{A}$ , typically.

### 7.4 Device Functional Modes

#### 7.4.1 Internal Offset Correction

INA333 internal operational amplifiers use an auto-calibration technique with a time-continuous 350-kHz operational amplifier in the signal path. The amplifier is zero-corrected every 8  $\mu\text{s}$  using a proprietary technique. Upon power up, the amplifier requires approximately 100  $\mu\text{s}$  to achieve specified VOS accuracy. This design has no aliasing or flicker noise.

#### 7.4.2 Input Common-Mode Range

The linear input voltage range of the input circuitry of the INA333 is from approximately 0.1 V below the positive supply voltage to 0.1 V above the negative supply. As a differential input voltage causes the output voltage to increase, however, the linear input range is limited by the output voltage swing of amplifiers A1 and A2. Thus, the linear common-mode input range is related to the output voltage of the complete amplifier. This behavior also depends on supply voltage—see [Figure 20](#).

Input overload conditions can produce an output voltage that appears normal. For example, if an input overload condition drives both input amplifiers to the respective positive output swing limit, the difference voltage measured by the output amplifier is near zero. The output of the INA333 is near 0 V even though both inputs are overloaded.

## 8 Application and Implementation

### NOTE

Information in the following applications sections is not part of the TI component specification, and TI does not warrant its accuracy or completeness. TI's customers are responsible for determining suitability of components for their purposes. Customers should validate and test their design implementation to confirm system functionality.

### 8.1 Application Information

The INA333 measures small differential voltage with high common-mode voltage developed between the noninverting and inverting input. The high input impedance makes the INA333 suitable for a wide range of applications. The ability to set the reference pin to adjust the functionality of the output signal offers additional flexibility that is practical for multiple configurations.

### 8.2 Typical Application

Figure 32 shows the basic connections required for operation of the INA333 device. Good layout practice mandates the use of bypass capacitors placed close to the device pins as shown.

The output of the INA333 device is referred to the output reference (REF) pin, which is normally grounded. This connection must be low-impedance to assure good common-mode rejection. Although 15  $\Omega$  or less of stray resistance can be tolerated while maintaining specified CMRR, small stray resistances of tens of  $\Omega$ s in series with the REF pin can cause noticeable degradation in CMRR.

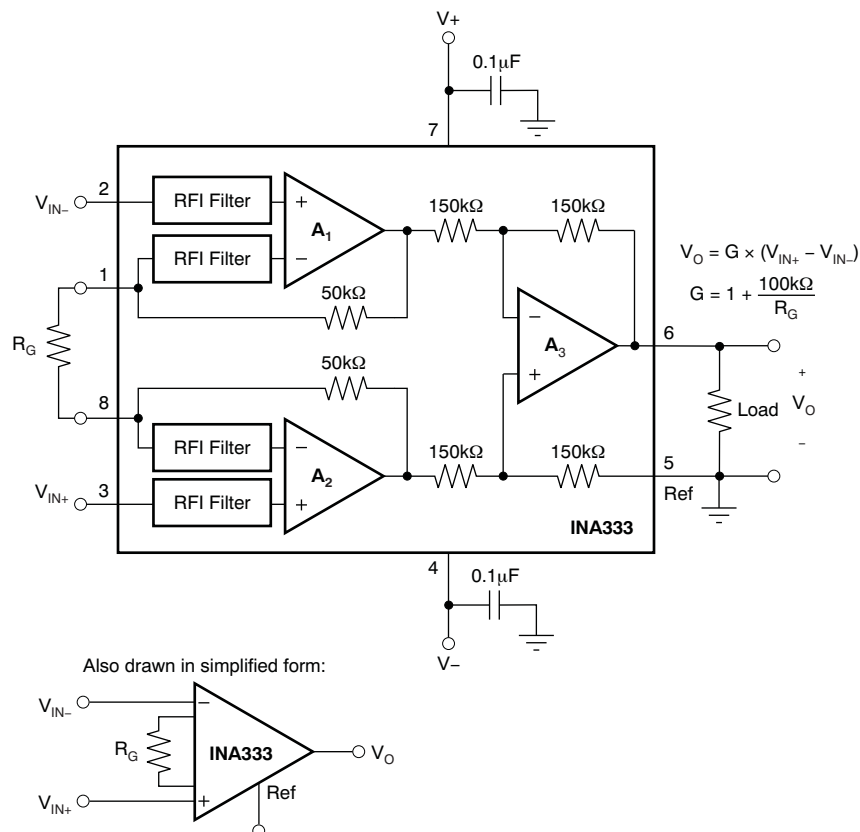

**Figure 32. Basic Connections**

## Typical Application (continued)

### 8.2.1 Design Requirements

The device can be configured to monitor the input differential voltage when the gain of the input signal is set by the external resistor  $R_G$ . The output signal references to the Ref pin. The most common application is where the output is referenced to ground when no input signal is present by connecting the Ref pin to ground. When the input signal increases, the output voltage at the OUT pin increases, too.

### 8.2.2 Detailed Design Procedure

#### 8.2.2.1 Setting the Gain

Gain of the INA333 device is set by a single external resistor,  $R_G$ , connected between pins 1 and 8. The value of  $R_G$  is selected according to [Equation 1](#):

$$G = 1 + (100 \text{ k}\Omega / R_G) \quad (1)$$

[Table 1](#) lists several commonly-used gains and resistor values. The 100 k $\Omega$  in [Equation 1](#) comes from the sum of the two internal feedback resistors of  $A_1$  and  $A_2$ . These on-chip resistors are laser trimmed to accurate absolute values. The accuracy and temperature coefficient of these resistors are included in the gain accuracy and drift specifications of the INA333 device.

The stability and temperature drift of the external gain setting resistor,  $R_G$ , also affects gain. The contribution of  $R_G$  to gain accuracy and drift can be directly inferred from the gain [Equation 1](#). Low resistor values required for high gain can make wiring resistance important. Sockets add to the wiring resistance and contribute additional gain error (possibly an unstable gain error) in gains of approximately 100 or greater. To ensure stability, avoid parasitic capacitance of more than a few picofarads at the  $R_G$  connections. Careful matching of any parasitics on both  $R_G$  pins maintains optimal CMRR over frequency.

**Table 1. Commonly-Used Gains and Resistor Values**

DESIRED GAIN	$R_G$ ( $\Omega$ )	NEAREST 1% $R_G$ ( $\Omega$ )
1	NC <sup>(1)</sup>	NC
2	100k	100k
5	25k	24.9k
10	11.1k	11k
20	5.26k	5.23k
50	2.04k	2.05
100	1.01k	1k
200	502.5	499
500	200.4	200
1000	100.1	100

(1) NC denotes no connection. When using the SPICE model, the simulation will not converge unless a resistor is connected to the  $R_G$  pins; use a very large resistor value.

#### 8.2.2.2 Internal Offset Correction

The INA333 device internal operational amplifiers use an auto-calibration technique with a time-continuous 350-kHz operational amplifier in the signal path. The amplifier is zero-corrected every 8  $\mu$ s using a proprietary technique. Upon power-up, the amplifier requires approximately 100  $\mu$ s to achieve specified  $V_{OS}$  accuracy. This design has no aliasing or flicker noise.

#### 8.2.2.3 Offset Trimming

Most applications require no external offset adjustment; however, if necessary, adjustments can be made by applying a voltage to the REF pin. [Figure 33](#) shows an optional circuit for trimming the output offset voltage. The voltage applied to REF pin is summed at the output. The operational amplifier buffer provides low impedance at the REF pin to preserve good common-mode rejection.

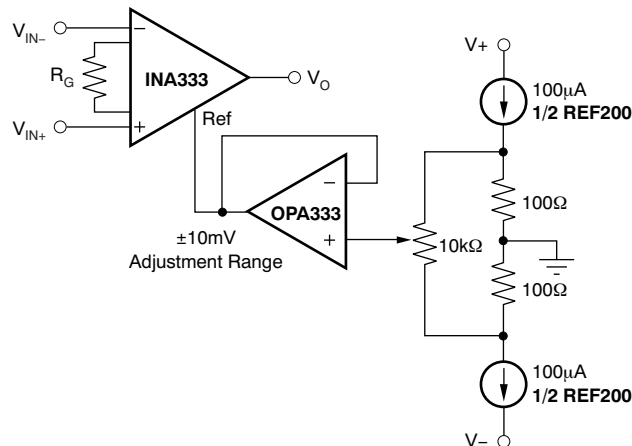

**Figure 33. Optional Trimming of Output Offset Voltage**

#### 8.2.2.4 Noise Performance

The auto-calibration technique used by the INA333 device results in reduced low frequency noise, typically only  $50 \text{ nV}/\sqrt{\text{Hz}}$ , ( $G = 100$ ). The spectral noise density can be seen in detail in [Figure 8](#). Low frequency noise of the INA333 device is approximately  $1 \text{ } \mu\text{V}_{\text{PP}}$  measured from 0.1 Hz to 10 Hz, ( $G = 100$ ).

#### 8.2.2.5 Input Bias Current Return Path

The input impedance of the INA333 device is extremely high—approximately 100 GΩ. However, a path must be provided for the input bias current of both inputs. This input bias current is typically  $\pm 70 \text{ pA}$ . High input impedance means that this input bias current changes very little with varying input voltage.

Input circuitry must provide a path for this input bias current for proper operation. [Figure 34](#) shows various provisions for an input bias current path. Without a bias current path, the inputs float to a potential that exceeds the common-mode range of the INA333 device, and the input amplifiers will saturate. If the differential source resistance is low, the bias current return path can be connected to one input (see the thermocouple example in [Figure 34](#)). With higher source impedance, using two equal resistors provides a balanced input with possible advantages of lower input offset voltage as a result of bias current and better high-frequency common-mode rejection.

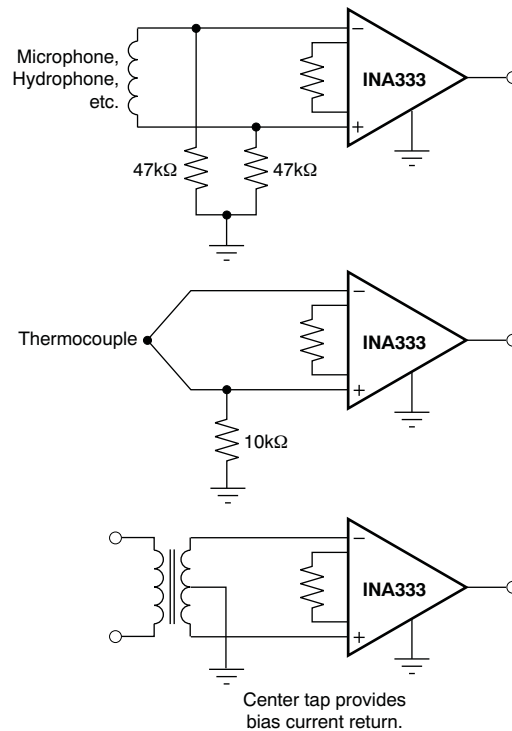

**Figure 34. Providing an Input Common-Mode Current Path**

#### 8.2.2.6 Input Common-Mode Range

The linear input voltage range of the input circuitry of the INA333 device is from approximately 0.1 V below the positive supply voltage to 0.1 V above the negative supply. As a differential input voltage causes the output voltage to increase, however, the linear input range is limited by the output voltage swing of amplifiers  $A_1$  and  $A_2$ . Thus, the linear common-mode input range is related to the output voltage of the complete amplifier. This behavior also depends on supply voltage—see Figure 20 to Figure 23 in the *Typical Characteristics* section.

Input overload conditions can produce an output voltage that appears normal. For example, if an input overload condition drives both input amplifiers to the respective positive output swing limit, the difference voltage measured by the output amplifier is near zero. The output of the INA333 is near 0 V even though both inputs are overloaded.

#### 8.2.2.7 Operating Voltage

The INA333 operates over a power-supply range of 1.8 V to 5.5 V ( $\pm 0.9$  V to  $\pm 2.75$  V). Supply voltages higher than 7 V (absolute maximum) can permanently damage the device. Parameters that vary over supply voltage or temperature are shown in the *Typical Characteristics* section of this data sheet.

#### 8.2.2.8 Low Voltage Operation

The INA333 device can be operated on power supplies as low as  $\pm 0.9$  V. Most parameters vary only slightly throughout this supply voltage range—see the *Typical Characteristics* section. Operation at very low supply voltage requires careful attention to assure that the input voltages remain within the linear range. Voltage swing requirements of internal nodes limit the input common-mode range with low power-supply voltage. Figure 20 to Figure 23 show the range of linear operation for various supply voltages and gains.

#### 8.2.2.9 Single-Supply Operation

The INA333 device can be used on single power supplies of 1.8 V to 5.5 V. Figure 35 shows a basic single-supply circuit. The output REF pin is connected to mid-supply. Zero differential input voltage demands an output voltage of mid-supply. Actual output voltage swing is limited to approximately 50 mV more than ground, when the load is referred to ground as shown. Figure 29 shows how the output voltage swing varies with output current.

With single-supply operation,  $V_{IN+}$  and  $V_{IN-}$  must both be 0.1 V more than ground for linear operation. For instance, the inverting input cannot be connected to ground to measure a voltage connected to the noninverting input.

To show the issues affecting low voltage operation, consider the circuit in [Figure 35](#). It shows the INA333 device operating from a single 3-V supply. A resistor in series with the low side of the bridge assures that the bridge output voltage is within the common-mode range of the amplifier inputs.

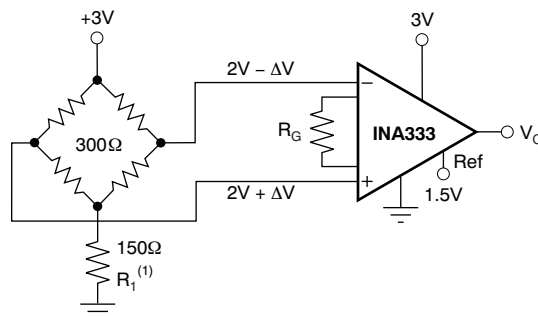

- (1)  $R_1$  creates proper common-mode voltage, only for low-voltage operation—see [Single-Supply Operation](#).

**Figure 35. Single-Supply Bridge Amplifier**

### 8.2.2.10 Input Protection

The input pins of the INA333 device are protected with internal diodes connected to the power-supply rails. These diodes clamp the applied signal to prevent it from damaging the input circuitry. If the input signal voltage can exceed the power supplies by more than 0.3 V, the input signal current should be limited to less than 10 mA to protect the internal clamp diodes. This current limiting can generally be done with a series input resistor. Some signal sources are inherently current-limited and do not require limiting resistors.

### 8.2.3 Application Curves

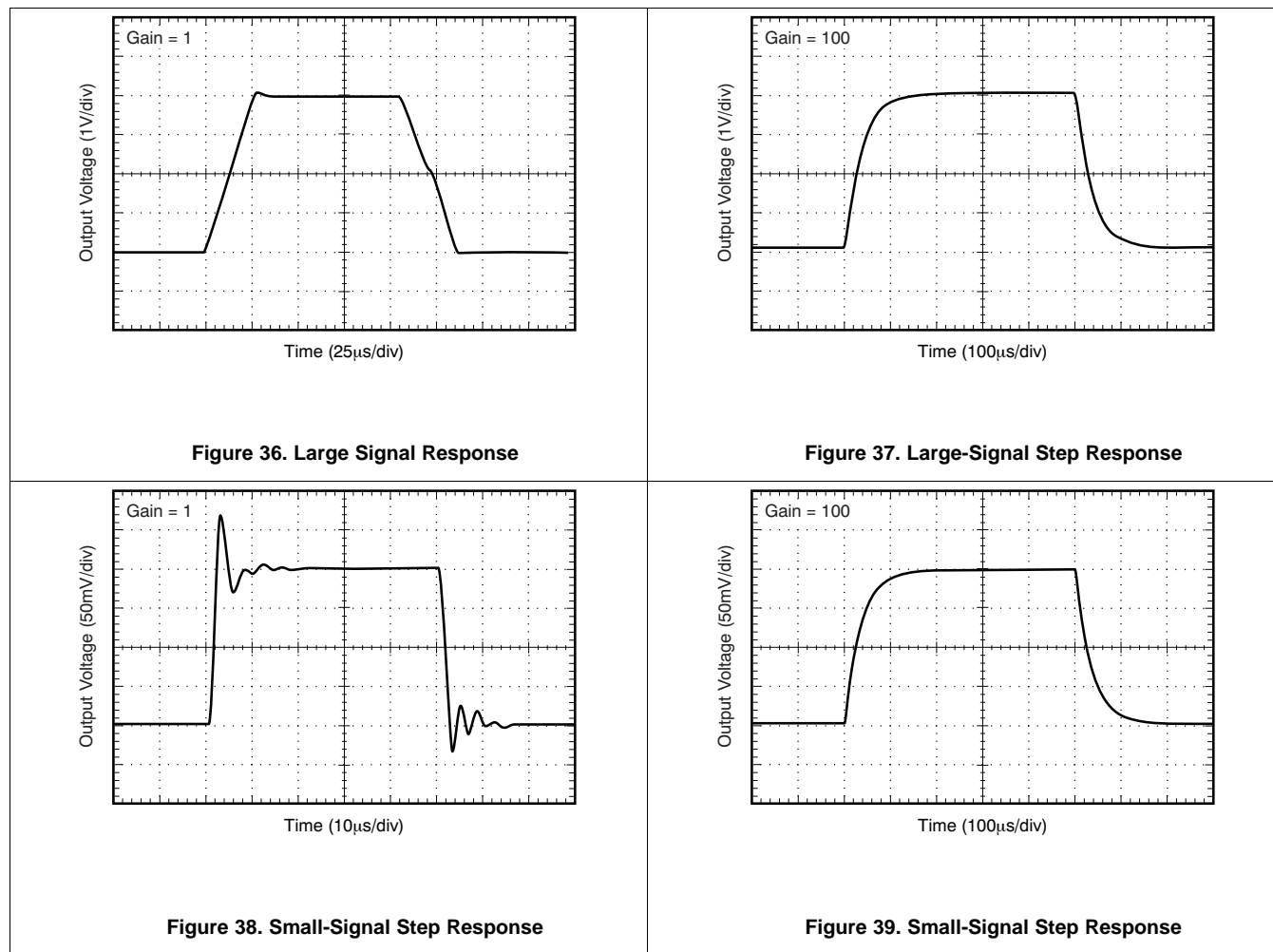

## 9 Power Supply Recommendations

The minimum power supply voltage for INA333 is 1.8 V and the maximum power supply voltage is 5.5 V. For optimum performance, 3.3 V to 5 V is recommended. TI recommends adding a bypass capacitor at the input to compensate for the layout and power supply source impedance.

## 10 Layout

### 10.1 Layout Guidelines

Attention to good layout practices is always recommended. Keep traces short and, when possible, use a printed-circuit-board (PCB) ground plane with surface-mount components placed as close to the device pins as possible. Place a 0.1- $\mu\text{F}$  bypass capacitor closely across the supply pins. These guidelines should be applied throughout the analog circuit to improve performance and provide benefits such as reducing the electromagnetic-interference (EMI) susceptibility.

Instrumentation amplifiers vary in the susceptibility to radio-frequency interference (RFI). RFI can generally be identified as a variation in offset voltage or DC signal levels with changes in the interfering RF signal. The INA333 device has been specifically designed to minimize susceptibility to RFI by incorporating passive RC filters with an 8-MHz corner frequency at the  $V_{\text{IN}+}$  and  $V_{\text{IN}-}$  inputs. As a result, the INA333 device demonstrates remarkably low sensitivity compared to previous generation devices. Strong RF fields may continue to cause varying offset levels, however, and may require additional shielding.

### 10.2 Layout Example

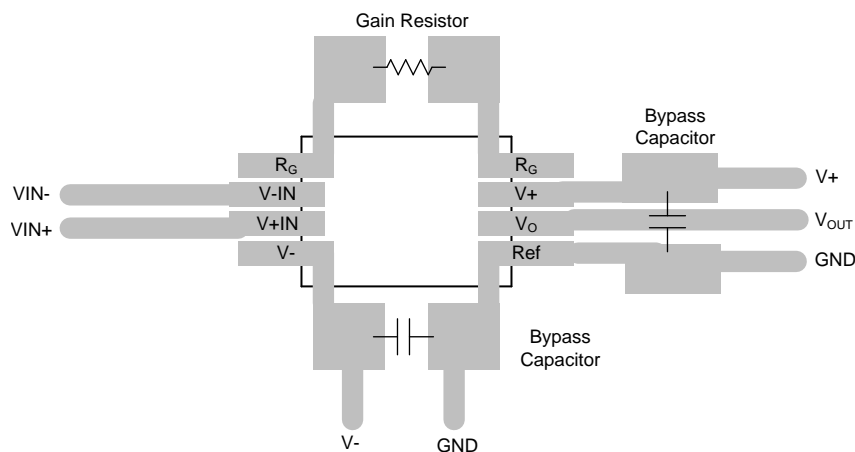

**Figure 40. INA333 Layout**

## 11 Device and Documentation Support

### 11.1 Device Support

#### 11.1.1 Development Support

##### 11.1.1.1 TINA-TI (Free Download Software)

##### Using TINA-TI SPICE-Based Analog Simulation Program with the INA333

TINA is a simple, powerful, and easy-to-use circuit simulation program based on a SPICE engine. TINA-TI is a free, fully functional version of the TINA software, preloaded with a library of macromodels in addition to a range of both passive and active models. It provides all the conventional DC, transient, and frequency domain analysis of SPICE as well as additional design capabilities.

Available as a free download from the [Analog eLab Design Center](#), TINA-TI offers extensive post-processing capability that allows users to format results in a variety of ways.

Virtual instruments offer users the ability to select input waveforms and probe circuit nodes, voltages, and waveforms, creating a dynamic quick-start tool.

Figure 41 and Figure 42 show example TINA-TI circuits for the INA333 device that can be used to develop, modify, and assess the circuit design for specific applications. Links to download these simulation files are given below.

#### NOTE

These files require that either the TINA software (from DesignSoft) or TINA-TI software be installed. Download the free TINA-TI software from the TINA-TI folder.

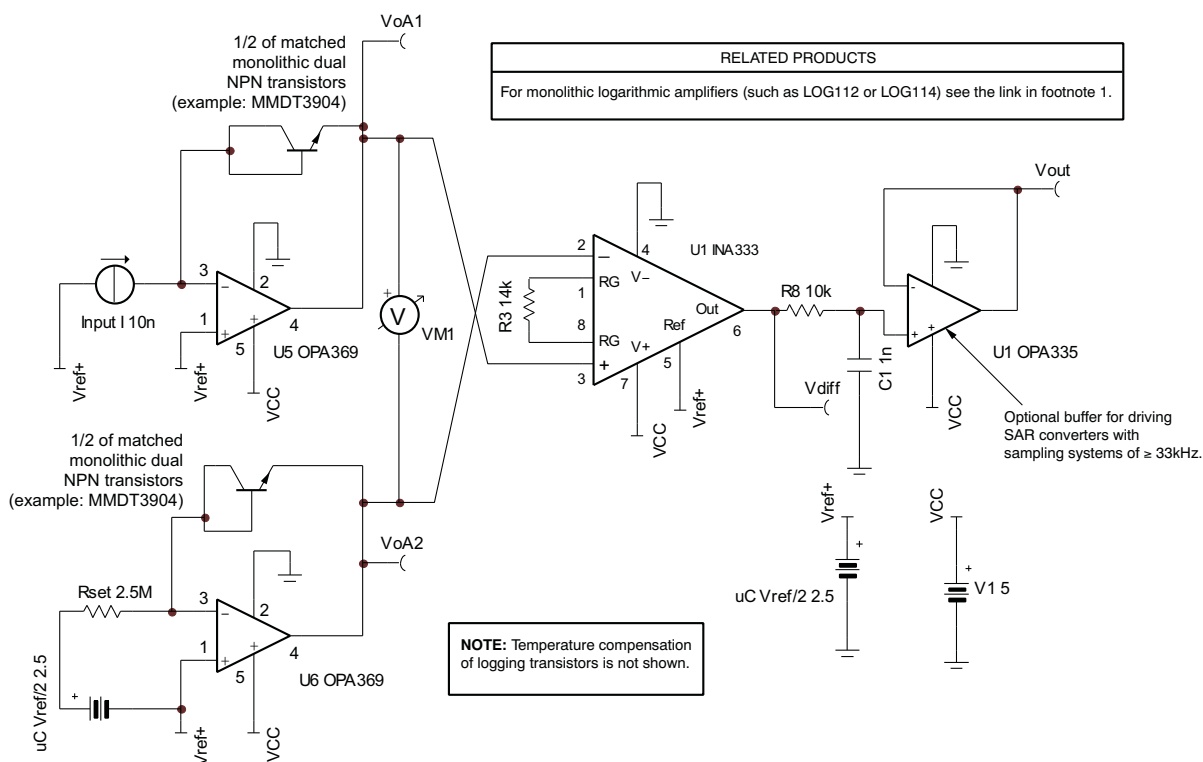

(1) The following link launches the TI logarithmic amplifiers web page: [Logarithmic Amplifier Products Home Page](#)

**Figure 41. Low-Power Log Function Circuit for Portable Battery-Powered Systems (Example Glucose Meter)**

## Device Support (continued)

To download a compressed file that contains the TINA-TI simulation file for this circuit, click the following link: [Log Circuit](#).

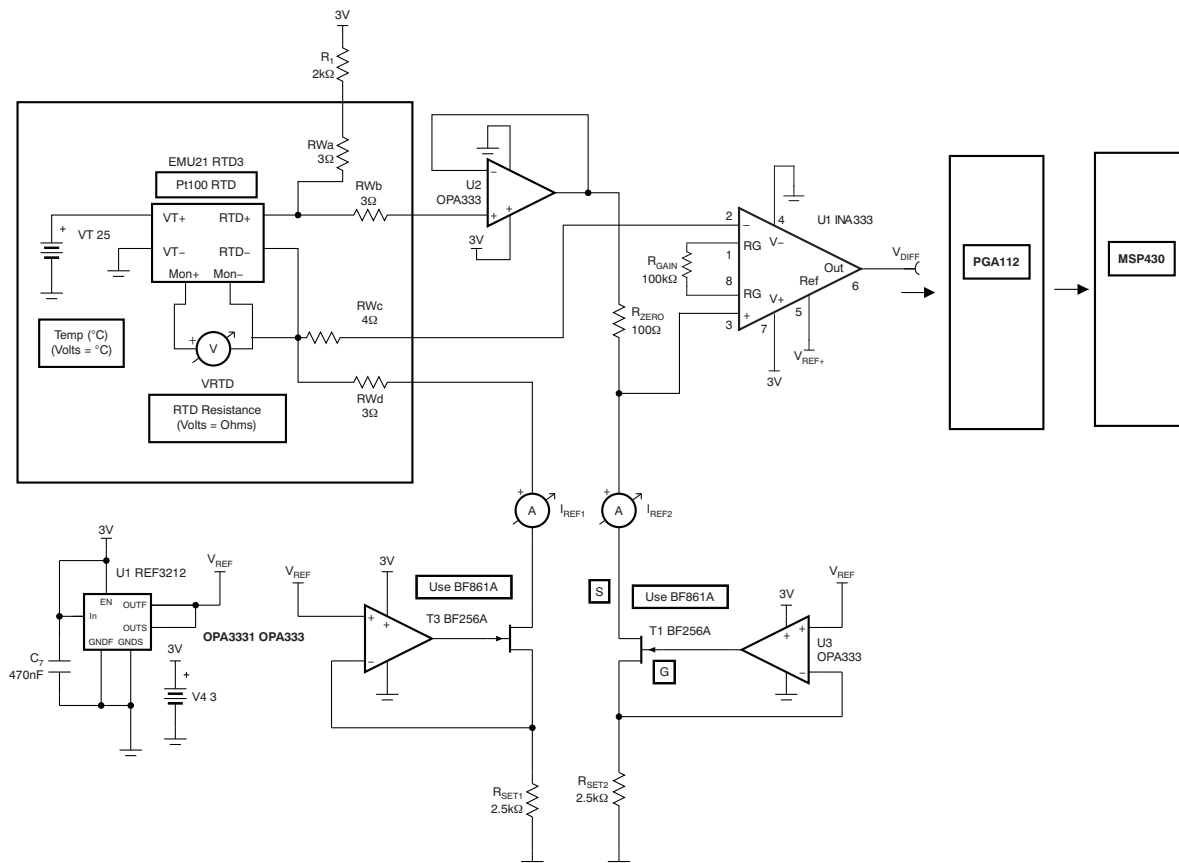

RW<sub>a</sub>, RW<sub>b</sub>, RW<sub>c</sub>, and RW<sub>d</sub> simulate wire resistance. These resistors are included to show the four-wire sense technique immunity to line mismatches. This method assumes the use of a four-wire RTD.

**Figure 42. Four-Wire, 3-V Conditioner for a PT100 RTD With Programmable Gain Acquisition System**

To download a compressed file that contains the TINA-TI simulation file for this circuit, click the following link: [PT100 RTD](#).

## 11.2 Documentation Support

### 11.2.1 Related Documentation

For related documentation see the following:

- *Precision, Low-Noise, Rail-to-Rail Output, 36-V, Zero-Drift Operational Amplifiers*, [SBOS642](#)
- *50µV VOS, 0.25µV/°C, 35µA CMOS OPERATIONAL AMPLIFIERS Zero-Drift Series*, [SBOS432](#)
- *4ppm/°C, 100µA, SOT23-6 SERIES VOLTAGE REFERENCE*, [SBVS058](#)
- *Circuit Board Layout Techniques*, [SLOA089](#)

## 11.3 Trademarks

All trademarks are the property of their respective owners.

## 11.4 Electrostatic Discharge Caution



These devices have limited built-in ESD protection. The leads should be shorted together or the device placed in conductive foam during storage or handling to prevent electrostatic damage to the MOS gates.

## 11.5 Glossary

[SLYZ022](#) — *TI Glossary*.

This glossary lists and explains terms, acronyms, and definitions.

## 12 Mechanical, Packaging, and Orderable Information

The following pages include mechanical, packaging, and orderable information. This information is the most current data available for the designated devices. This data is subject to change without notice and revision of this document. For browser-based versions of this data sheet, refer to the left-hand navigation.

**PACKAGING INFORMATION**

Orderable Device	Status (1)	Package Type	Package Drawing	Pins	Package Qty	Eco Plan (2)	Lead/Ball Finish (6)	MSL Peak Temp (3)	Op Temp (°C)	Device Marking (4/5)	Samples
INA333AIDGKR	ACTIVE	VSSOP	DGK	8	2500	Green (RoHS & no Sb/Br)	CU NIPDAU   CU NIPDAUAG	Level-2-260C-1 YEAR	-40 to 125	I333	<a href="#">Samples</a>
INA333AIDGKRG4	ACTIVE	VSSOP	DGK	8	2500	Green (RoHS & no Sb/Br)	CU NIPDAUAG	Level-2-260C-1 YEAR	-40 to 125	I333	<a href="#">Samples</a>
INA333AIDGKT	ACTIVE	VSSOP	DGK	8	250	Green (RoHS & no Sb/Br)	CU NIPDAU   CU NIPDAUAG	Level-2-260C-1 YEAR	-40 to 125	I333	<a href="#">Samples</a>
INA333AIDGKTG4	ACTIVE	VSSOP	DGK	8	250	Green (RoHS & no Sb/Br)	CU NIPDAUAG	Level-2-260C-1 YEAR	-40 to 125	I333	<a href="#">Samples</a>
INA333AIDRGR	ACTIVE	SON	DRG	8	3000	Green (RoHS & no Sb/Br)	CU NIPDAU	Level-2-260C-1 YEAR	-40 to 125	I333A	<a href="#">Samples</a>
INA333AIDRGT	ACTIVE	SON	DRG	8	250	Green (RoHS & no Sb/Br)	CU NIPDAU	Level-2-260C-1 YEAR	-40 to 125	I333A	<a href="#">Samples</a>

(1) The marketing status values are defined as follows:

**ACTIVE:** Product device recommended for new designs.

**LIFEBUY:** TI has announced that the device will be discontinued, and a lifetime-buy period is in effect.

**NRND:** Not recommended for new designs. Device is in production to support existing customers, but TI does not recommend using this part in a new design.

**PREVIEW:** Device has been announced but is not in production. Samples may or may not be available.

**OBSELETE:** TI has discontinued the production of the device.

(2) **RoHS:** TI defines "RoHS" to mean semiconductor products that are compliant with the current EU RoHS requirements for all 10 RoHS substances, including the requirement that RoHS substance do not exceed 0.1% by weight in homogeneous materials. Where designed to be soldered at high temperatures, "RoHS" products are suitable for use in specified lead-free processes. TI may reference these types of products as "Pb-Free".

**RoHS Exempt:** TI defines "RoHS Exempt" to mean products that contain lead but are compliant with EU RoHS pursuant to a specific EU RoHS exemption.

**Green:** TI defines "Green" to mean the content of Chlorine (Cl) and Bromine (Br) based flame retardants meet JS709B low halogen requirements of <=1000ppm threshold. Antimony trioxide based flame retardants must also meet the <=1000ppm threshold requirement.

(3) MSL, Peak Temp. - The Moisture Sensitivity Level rating according to the JEDEC industry standard classifications, and peak solder temperature.

(4) There may be additional marking, which relates to the logo, the lot trace code information, or the environmental category on the device.

(5) Multiple Device Markings will be inside parentheses. Only one Device Marking contained in parentheses and separated by a "~" will appear on a device. If a line is indented then it is a continuation of the previous line and the two combined represent the entire Device Marking for that device.

<sup>(6)</sup> Lead/Ball Finish - Orderable Devices may have multiple material finish options. Finish options are separated by a vertical ruled line. Lead/Ball Finish values may wrap to two lines if the finish value exceeds the maximum column width.

**Important Information and Disclaimer:**The information provided on this page represents TI's knowledge and belief as of the date that it is provided. TI bases its knowledge and belief on information provided by third parties, and makes no representation or warranty as to the accuracy of such information. Efforts are underway to better integrate information from third parties. TI has taken and continues to take reasonable steps to provide representative and accurate information but may not have conducted destructive testing or chemical analysis on incoming materials and chemicals. TI and TI suppliers consider certain information to be proprietary, and thus CAS numbers and other limited information may not be available for release.

In no event shall TI's liability arising out of such information exceed the total purchase price of the TI part(s) at issue in this document sold by TI to Customer on an annual basis.

**OTHER QUALIFIED VERSIONS OF INA333 :**

NOTE: Qualified Version Definitions:

**TAPE AND REEL INFORMATION**

**QUADRANT ASSIGNMENTS FOR PIN 1 ORIENTATION IN TAPE**

\*All dimensions are nominal

Device	Package Type	Package Drawing	Pins	SPQ	Reel Diameter (mm)	Reel Width W1 (mm)	A0 (mm)	B0 (mm)	K0 (mm)	P1 (mm)	W (mm)	Pin1 Quadrant
INA333AIDGKR	VSSOP	DGK	8	2500	330.0	12.4	5.3	3.4	1.4	8.0	12.0	Q1
INA333AIDGKT	VSSOP	DGK	8	250	330.0	12.4	5.3	3.4	1.4	8.0	12.0	Q1
INA333AIDRGR	SON	DRG	8	3000	330.0	12.4	3.3	3.3	1.1	8.0	12.0	Q2
INA333AIDRGT	SON	DRG	8	250	180.0	12.4	3.3	3.3	1.1	8.0	12.0	Q2

**TAPE AND REEL BOX DIMENSIONS**

\*All dimensions are nominal

Device	Package Type	Package Drawing	Pins	SPQ	Length (mm)	Width (mm)	Height (mm)
INA333AIDGKR	VSSOP	DGK	8	2500	366.0	364.0	50.0
INA333AIDGKT	VSSOP	DGK	8	250	366.0	364.0	50.0
INA333AIDRGR	SON	DRG	8	3000	367.0	367.0	35.0
INA333AIDRGT	SON	DRG	8	250	210.0	185.0	35.0

DGK (S-PDSO-G8)

PLASTIC SMALL-OUTLINE PACKAGE



- NOTES:
- A. All linear dimensions are in millimeters.
  - B. This drawing is subject to change without notice.
  - C. Body length does not include mold flash, protrusions, or gate burrs. Mold flash, protrusions, or gate burrs shall not exceed 0.15 per end.
  - D. Body width does not include interlead flash. Interlead flash shall not exceed 0.50 per side.
  - E. Falls within JEDEC MO-187 variation AA, except interlead flash.



- NOTES:
- A. All linear dimensions are in millimeters.
  - B. This drawing is subject to change without notice.
  - C. Publication IPC-7351 is recommended for alternate designs.
  - D. Laser cutting apertures with trapezoidal walls and also rounding corners will offer better paste release. Customers should contact their board assembly site for stencil design recommendations. Refer to IPC-7525 for other stencil recommendations.
  - E. Customers should contact their board fabrication site for solder mask tolerances between and around signal pads.

DRG (S-PWSON-N8)

PLASTIC SMALL OUTLINE NO-LEAD

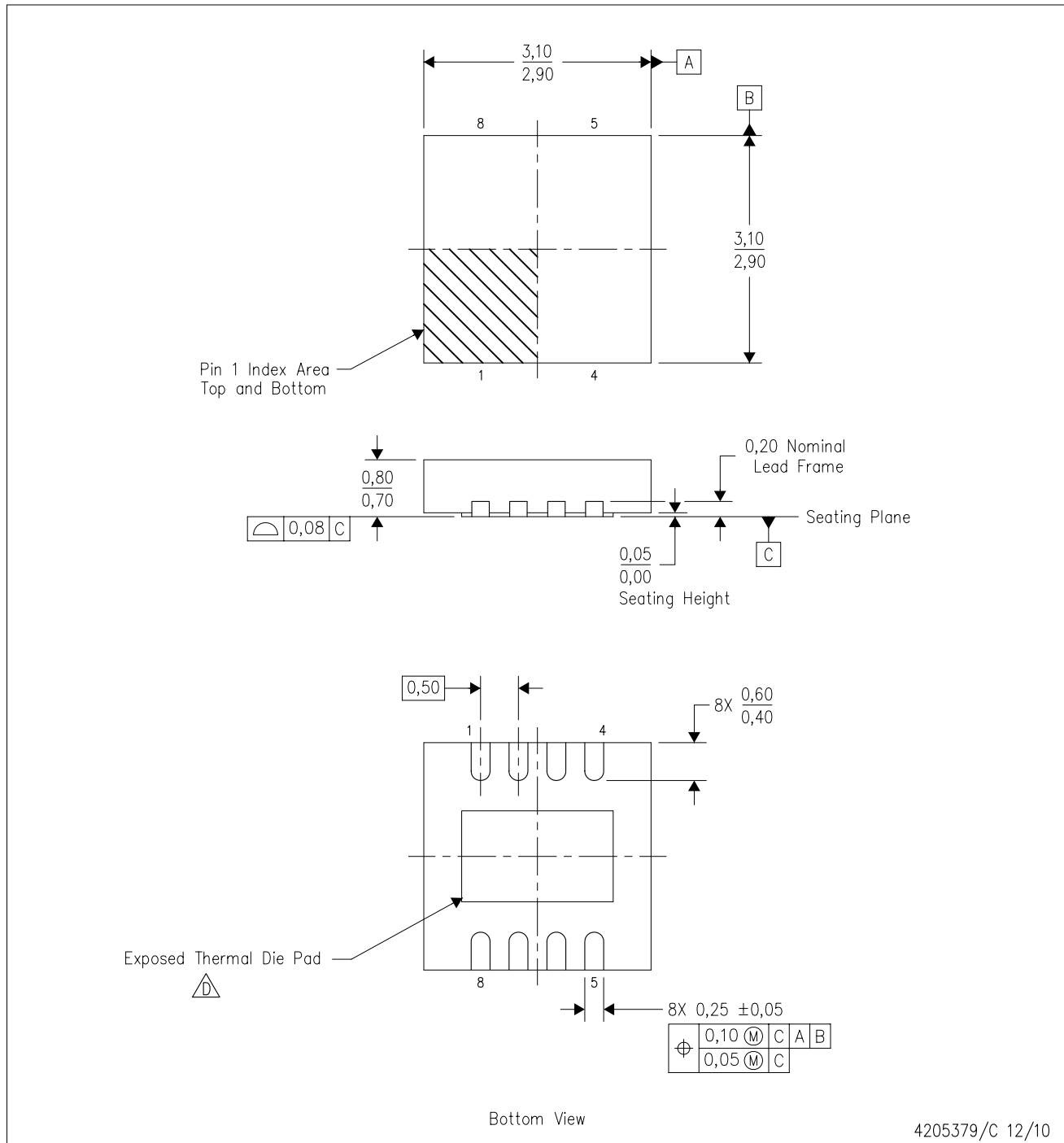

- NOTES:
- A. All linear dimensions are in millimeters. Dimensioning and tolerancing per ASME Y14.5M-1994.
  - B. This drawing is subject to change without notice.
  - C. SON (Small Outline No-Lead) package configuration.
  - △ The package thermal pad must be soldered to the board for thermal and mechanical performance. See the Product Data Sheet for details regarding the exposed thermal pad dimensions.
  - E. JEDEC MO-229 package registration pending.

# THERMAL PAD MECHANICAL DATA

DRG (S-PWSON-N8)

PLASTIC SMALL OUTLINE NO-LEAD

## THERMAL INFORMATION

This package incorporates an exposed thermal pad that is designed to be attached directly to an external heatsink. The thermal pad must be soldered directly to the printed circuit board (PCB). After soldering, the PCB can be used as a heatsink. In addition, through the use of thermal vias, the thermal pad can be attached directly to the appropriate copper plane shown in the electrical schematic for the device, or alternatively, can be attached to a special heatsink structure designed into the PCB. This design optimizes the heat transfer from the integrated circuit (IC).

For information on the Quad Flatpack No-Lead (QFN) package and its advantages, refer to Application Report, QFN/SON PCB Attachment, Texas Instruments Literature No. SLUA271. This document is available at [www.ti.com](http://www.ti.com).

The exposed thermal pad dimensions for this package are shown in the following illustration.

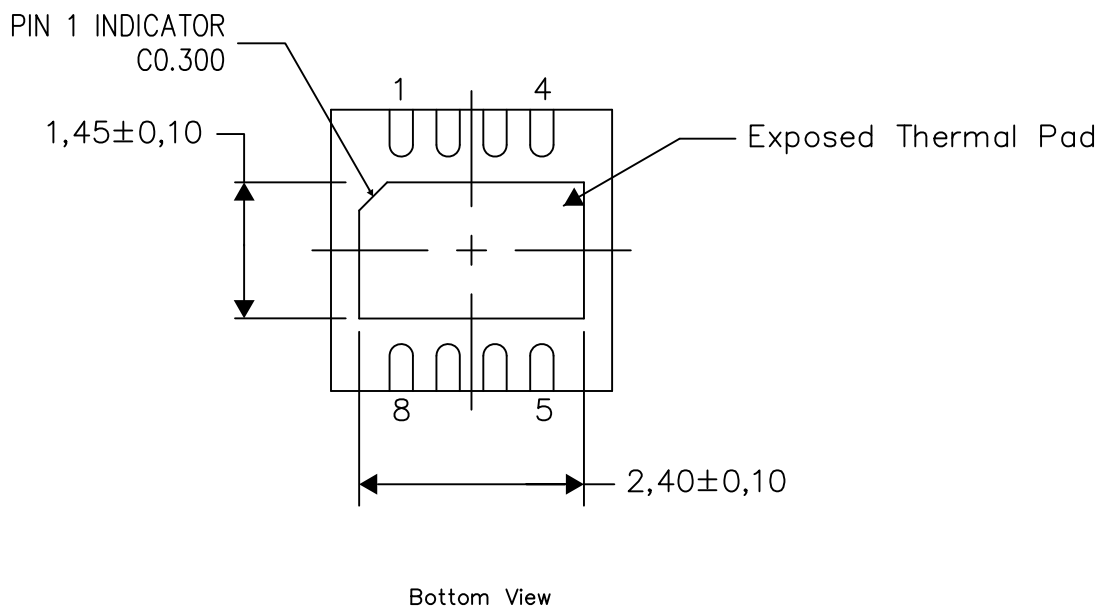

Exposed Thermal Pad Dimensions

4206881-3/1 03/15

NOTE: All linear dimensions are in millimeters

DRG (S-PWSON-N8)

PLASTIC SMALL OUTLINE NO-LEAD

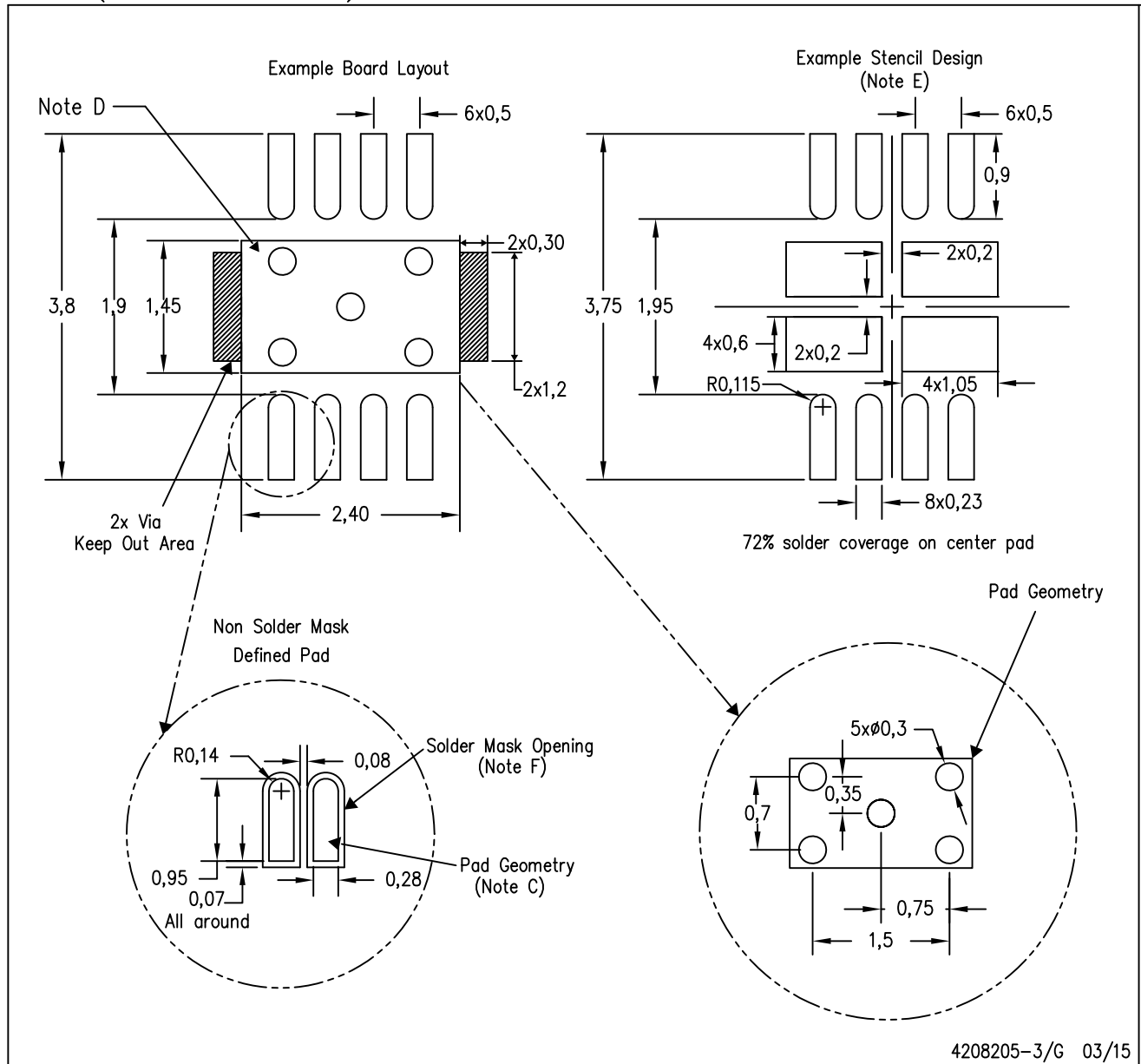

4208205-3/G 03/15

- NOTES:
- All linear dimensions are in millimeters.
  - This drawing is subject to change without notice.
  - Publication IPC-SM-782 is recommended for alternate designs.
  - This package is designed to be soldered to a thermal pad on the board. Refer to Application Note, Quad Flat-Pack Packages, Texas Instruments Literature No. SLUA271, and also the Product Data Sheets for specific thermal information, via requirements, and recommended board layout. These documents are available at [www.ti.com](http://www.ti.com) <<http://www.ti.com>>.
  - Laser cutting apertures with trapezoidal walls and also rounding corners will offer better paste release. Customers should contact their board assembly site for stencil design recommendations. Refer to IPC 7525 for stencil design considerations.
  - Customers should contact their board fabrication site for minimum solder mask web tolerances between signal pads.

## IMPORTANT NOTICE

Texas Instruments Incorporated (TI) reserves the right to make corrections, enhancements, improvements and other changes to its semiconductor products and services per JESD46, latest issue, and to discontinue any product or service per JESD48, latest issue. Buyers should obtain the latest relevant information before placing orders and should verify that such information is current and complete.

TI's published terms of sale for semiconductor products (<http://www.ti.com/sc/docs/stdterms.htm>) apply to the sale of packaged integrated circuit products that TI has qualified and released to market. Additional terms may apply to the use or sale of other types of TI products and services.

Reproduction of significant portions of TI information in TI data sheets is permissible only if reproduction is without alteration and is accompanied by all associated warranties, conditions, limitations, and notices. TI is not responsible or liable for such reproduced documentation. Information of third parties may be subject to additional restrictions. Resale of TI products or services with statements different from or beyond the parameters stated by TI for that product or service voids all express and any implied warranties for the associated TI product or service and is an unfair and deceptive business practice. TI is not responsible or liable for any such statements.

Buyers and others who are developing systems that incorporate TI products (collectively, "Designers") understand and agree that Designers remain responsible for using their independent analysis, evaluation and judgment in designing their applications and that Designers have full and exclusive responsibility to assure the safety of Designers' applications and compliance of their applications (and of all TI products used in or for Designers' applications) with all applicable regulations, laws and other applicable requirements. Designer represents that, with respect to their applications, Designer has all the necessary expertise to create and implement safeguards that (1) anticipate dangerous consequences of failures, (2) monitor failures and their consequences, and (3) lessen the likelihood of failures that might cause harm and take appropriate actions. Designer agrees that prior to using or distributing any applications that include TI products, Designer will thoroughly test such applications and the functionality of such TI products as used in such applications.

TI's provision of technical, application or other design advice, quality characterization, reliability data or other services or information, including, but not limited to, reference designs and materials relating to evaluation modules, (collectively, "TI Resources") are intended to assist designers who are developing applications that incorporate TI products; by downloading, accessing or using TI Resources in any way, Designer (individually or, if Designer is acting on behalf of a company, Designer's company) agrees to use any particular TI Resource solely for this purpose and subject to the terms of this Notice.

TI's provision of TI Resources does not expand or otherwise alter TI's applicable published warranties or warranty disclaimers for TI products, and no additional obligations or liabilities arise from TI providing such TI Resources. TI reserves the right to make corrections, enhancements, improvements and other changes to its TI Resources. TI has not conducted any testing other than that specifically described in the published documentation for a particular TI Resource.

Designer is authorized to use, copy and modify any individual TI Resource only in connection with the development of applications that include the TI product(s) identified in such TI Resource. NO OTHER LICENSE, EXPRESS OR IMPLIED, BY ESTOPPEL OR OTHERWISE TO ANY OTHER TI INTELLECTUAL PROPERTY RIGHT, AND NO LICENSE TO ANY TECHNOLOGY OR INTELLECTUAL PROPERTY RIGHT OF TI OR ANY THIRD PARTY IS GRANTED HEREIN, including but not limited to any patent right, copyright, mask work right, or other intellectual property right relating to any combination, machine, or process in which TI products or services are used. Information regarding or referencing third-party products or services does not constitute a license to use such products or services, or a warranty or endorsement thereof. Use of TI Resources may require a license from a third party under the patents or other intellectual property of the third party, or a license from TI under the patents or other intellectual property of TI.

TI RESOURCES ARE PROVIDED "AS IS" AND WITH ALL FAULTS. TI DISCLAIMS ALL OTHER WARRANTIES OR REPRESENTATIONS, EXPRESS OR IMPLIED, REGARDING RESOURCES OR USE THEREOF, INCLUDING BUT NOT LIMITED TO ACCURACY OR COMPLETENESS, TITLE, ANY EPIDEMIC FAILURE WARRANTY AND ANY IMPLIED WARRANTIES OF MERCHANTABILITY, FITNESS FOR A PARTICULAR PURPOSE, AND NON-INFRINGEMENT OF ANY THIRD PARTY INTELLECTUAL PROPERTY RIGHTS. TI SHALL NOT BE LIABLE FOR AND SHALL NOT DEFEND OR INDEMNIFY DESIGNER AGAINST ANY CLAIM, INCLUDING BUT NOT LIMITED TO ANY INFRINGEMENT CLAIM THAT RELATES TO OR IS BASED ON ANY COMBINATION OF PRODUCTS EVEN IF DESCRIBED IN TI RESOURCES OR OTHERWISE. IN NO EVENT SHALL TI BE LIABLE FOR ANY ACTUAL, DIRECT, SPECIAL, COLLATERAL, INDIRECT, PUNITIVE, INCIDENTAL, CONSEQUENTIAL OR EXEMPLARY DAMAGES IN CONNECTION WITH OR ARISING OUT OF TI RESOURCES OR USE THEREOF, AND REGARDLESS OF WHETHER TI HAS BEEN ADVISED OF THE POSSIBILITY OF SUCH DAMAGES.

Unless TI has explicitly designated an individual product as meeting the requirements of a particular industry standard (e.g., ISO/TS 16949 and ISO 26262), TI is not responsible for any failure to meet such industry standard requirements.

Where TI specifically promotes products as facilitating functional safety or as compliant with industry functional safety standards, such products are intended to help enable customers to design and create their own applications that meet applicable functional safety standards and requirements. Using products in an application does not by itself establish any safety features in the application. Designers must ensure compliance with safety-related requirements and standards applicable to their applications. Designer may not use any TI products in life-critical medical equipment unless authorized officers of the parties have executed a special contract specifically governing such use. Life-critical medical equipment is medical equipment where failure of such equipment would cause serious bodily injury or death (e.g., life support, pacemakers, defibrillators, heart pumps, neurostimulators, and implantables). Such equipment includes, without limitation, all medical devices identified by the U.S. Food and Drug Administration as Class III devices and equivalent classifications outside the U.S.

TI may expressly designate certain products as completing a particular qualification (e.g., Q100, Military Grade, or Enhanced Product). Designers agree that it has the necessary expertise to select the product with the appropriate qualification designation for their applications and that proper product selection is at Designers' own risk. Designers are solely responsible for compliance with all legal and regulatory requirements in connection with such selection.

Designer will fully indemnify TI and its representatives against any damages, costs, losses, and/or liabilities arising out of Designer's non-compliance with the terms and provisions of this Notice.

## Looking for pricing, stock, or lifecycle information?

Click below to explore more details on WIN SOURCE:

 [View INA333AIDRGT on WIN SOURCE](#)

 [Texas Instruments](#) Information

## Optimize Your Supply Chain with WIN SOURCE Solutions

-  Global Sourcing Solution
-  Obsolete Management
-  Cost Control Management
-  Shortage Management
-  Alternative Solution
-  Excess Inventory Management