



**THE DATASHEET OF
OPB950Z**



Photologic® Dual Channel Encoder

OPB950Z

Obsolete (OPB951)

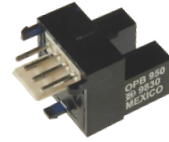

Features:

- Dual channel outputs for Quadrature Output
- Open collector inverter outputs
- 0.010" (0.254 mm) sensor apertures for high resolution
- Snap mount

Description:

The OPB950Z consists of an infrared Light Emitting Diode (LED) and a monolithic integrated circuit which incorporates two independent photodiodes, linear amplifiers, Schmitt trigger circuits and output transistors. It features a dual open-collector output that is compatible with TTL/LSTTL and can drive up to 8 TTL loads.

Applications include linear and rotary encoders with high resolution provided by internal 0.010" (0.254 mm) apertures located in front of each Photologic® sensor on 0.040" (1.02 mm) center line spacing.

Custom electrical, wire, cabling and connectors are available. Contact your local representative or OPTEK for more information.

Applications:

- Mechanical switch replacement
- Speed and direction indication
- Mechanical limit indication
- Rotary encoders
- Edge sensing
- Sliding Door Automotive and Liftgate applications

Ordering Information					
Part Number	LED Peak Wavelength	Sensor	Slot Width / Depth	Aperture Emitter/ Sensor	Connector
OPB950Z	890 nm	Dual TTL	0.200" / 0.350"	0.05" / 0.01"	Wellpex C25002WS-04-LF
OPB951 Obsolete					

OPB950Z

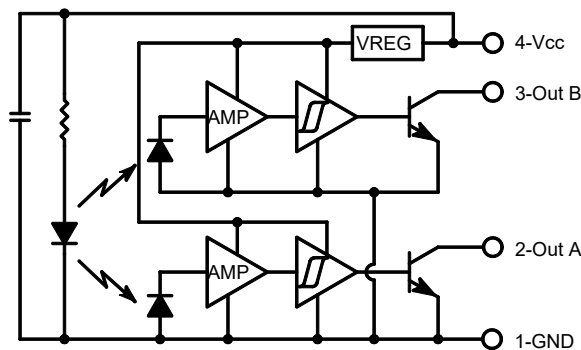

RoHS

General Note

TT Electronics reserves the right to make changes in product specification without notice or liability. All information is subject to TT Electronics' own data and is considered accurate at time of going to print.

© TT electronics plc

TT Electronics | OPTEK Technology
2900 E. Plano Pkwy, Plano, TX 75074 | Ph: +1 972 323 2200
www.ttelectronics.com | sensors@ttelectronics.com

Rev B 04/2023 Page 1

Photologic® Dual Channel Encoder

OPB950Z

Obsolete (OPB951)



Electrical Specifications

Absolute Maximum Ratings ($T_A = 25^\circ\text{C}$ unless otherwise noted)

Storage & Operating Temperature Range	-40° C to +85° C
---------------------------------------	------------------

Input Diode

Forward DC Current	50 mA
Reverse DC Voltage	2.0 V
Power Dissipation	100 mW

Output Photologic®

Supply Voltage, V_{CC}	5.5 V
Voltage at Output	16 V
Power Dissipation	200 mW
Sinking Output Current	40 mA

Electrical Characteristics ($T_A = 25^\circ\text{C}$ and $V_{CC} = +5$ Volts unless otherwise noted)

SYMBOL	PARAMETER	MIN	TYP	MAX	UNITS	TEST CONDITIONS
V_{CC}	Operating Supply Voltage	4.5	-	5.5	V	-
$E_{ET}^{(+)} / E_{ET}^{(-)}$	Hysteresis Ratio	1.1	1.5	2	-	-
MATCH	Channel Match $E_{ET}^{(+A)} / E_{ET}^{(+B)}$	0.67	1	1.5	-	-
I_{CCL}	Supply Current, Both Outputs Low (LED On, No Target)	-	8.5	12	mA	$E_E = 0.5\text{ mW/cm}^2$ (no load on output)
I_{CCH}	Supply Current, Both Outputs High (LED Off)	-	3.5	6	mA	$E_E = 0\text{ mW/cm}^2$ (no load on output)
I_{CCM}	Supply Current, Mixed Output States (one high, one low)	-	6	-	mA	$E_E = 0\text{ mW/cm}^2$ and 0.5 mW/cm^2
I_{oh}	High Level Output Current	-	1	30	μA	$E_E = 0\text{ mW/cm}^2$, $V_{OH} = 16\text{ V}$
V_{OL}	Low Level Output Voltage	-	0.21	0.4	V	$E_E = 0\text{ mW/cm}^2$, $I_{OL} = 12.8\text{ mA}$
T_{PHL} T_{PLH}	Propagation Delay Output High to Low Output Low to High	-	2 10	-	μs μs	$V_{CC} = 5\text{ V}$, $R_L = 360\ \Omega$ $E_E = 0$ or 0.5 mW/cm^2 , $f = 10\text{ kHz}$, D.C. = 50%
t_r t_f	Output Rise Time Output Fall Time	-	20 15	-	ns ns	-

General Note

TT Electronics reserves the right to make changes in product specification without notice or liability. All information is subject to TT Electronics' own data and is considered accurate at time of going to print.

TT Electronics | OPTEK Technology
2900 E. Plano Pkwy, Plano, TX 75074 | Ph: +1 972 323 2200
www.ttelectronics.com | sensors@ttelectronics.com

Performance

High Level Output vs Ambient Temperature

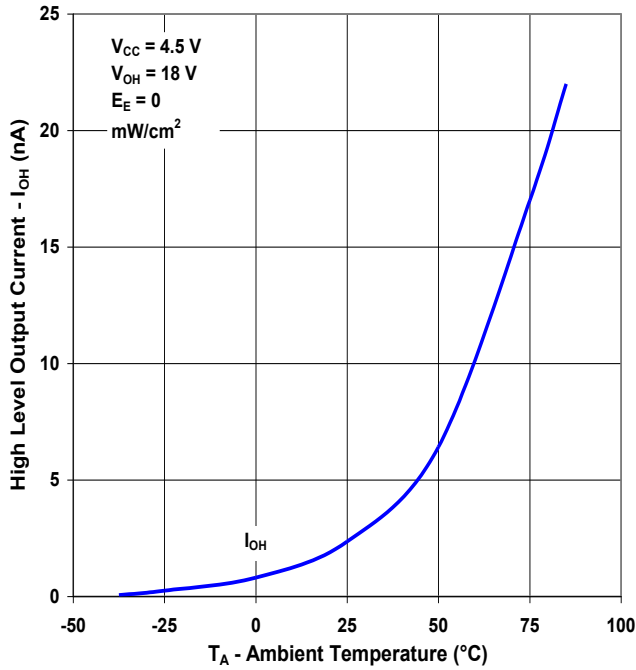

Low Level Output vs Ambient Temperature

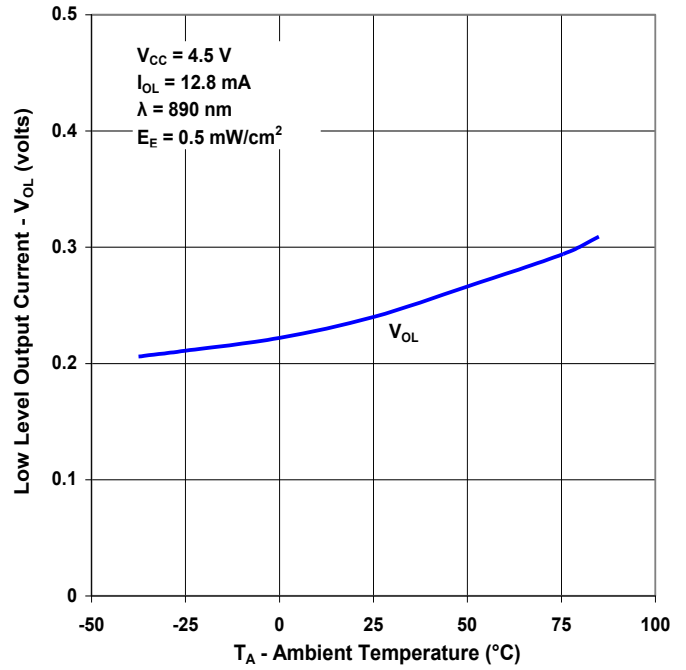

Supply Current vs Ambient Temperature

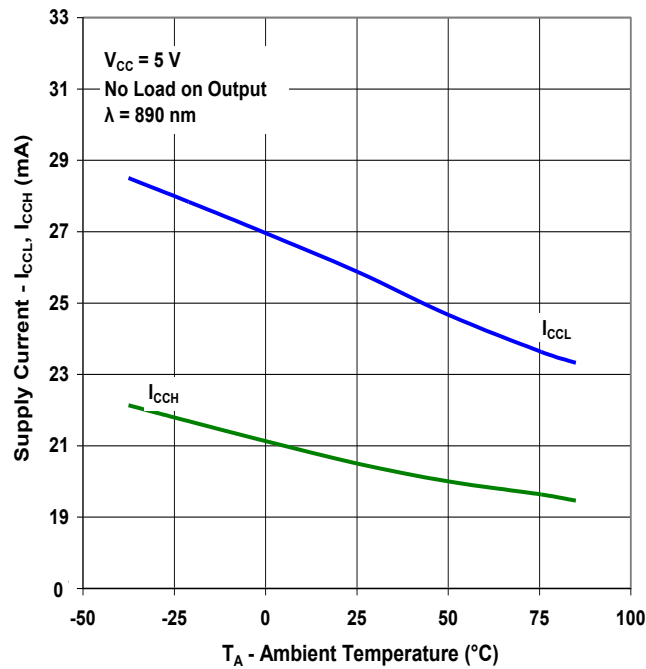

General Note

TT Electronics reserves the right to make changes in product specification without notice or liability. All information is subject to TT Electronics' own data and is considered accurate at time of going to print.

TT Electronics | OPTEK Technology
 2900 E. Plano Pkwy, Plano, TX 75074 | Ph: +1 972 323 2200
www.ttelectronics.com | sensors@ttelectronics.com

Performance

Rise and Fall Time vs Ambient Temperature vs Output Load

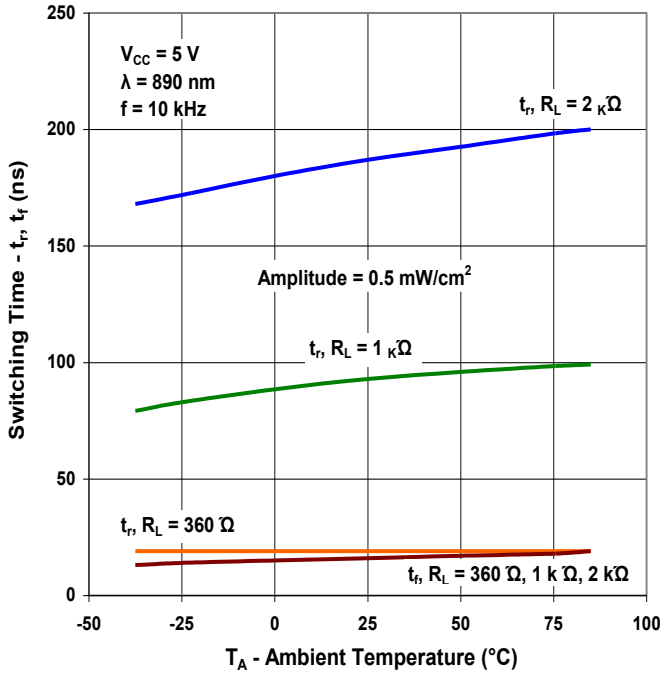

Propagation Delay vs Ambient Temperature

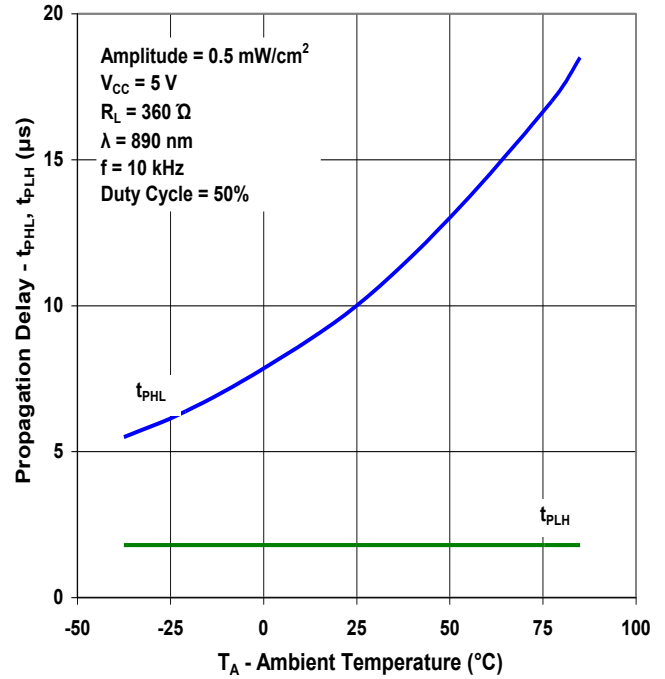

Sensor Output(s)

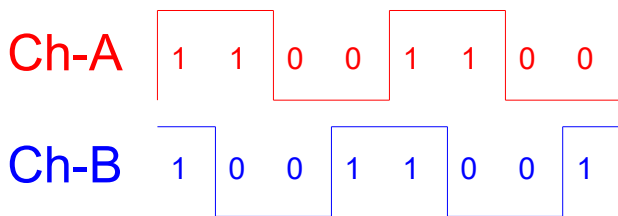

Ideal Target Size & Spacing For Linear or Circular Targets

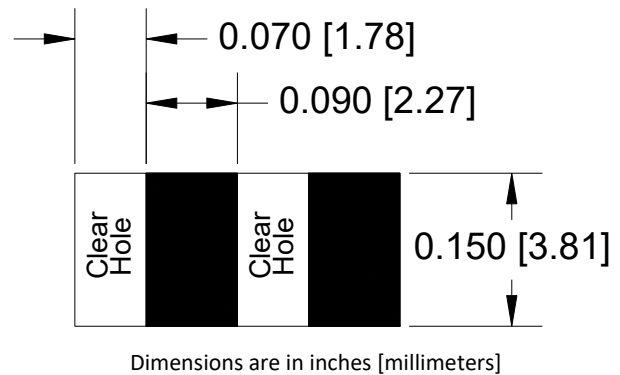

Please consult OPTEK for target design and sensor location relative to the target.

General Note

TT Electronics reserves the right to make changes in product specification without notice or liability. All information is subject to TT Electronics' own data and is considered accurate at time of going to print.

Photologic® Dual Channel Encoder

OPB950Z

Obsolete (OPB951)



Packaging

OPB950Z

Pin #	Description
1	Ground
2	Output-A
3	Output-B
4	V _{CC}

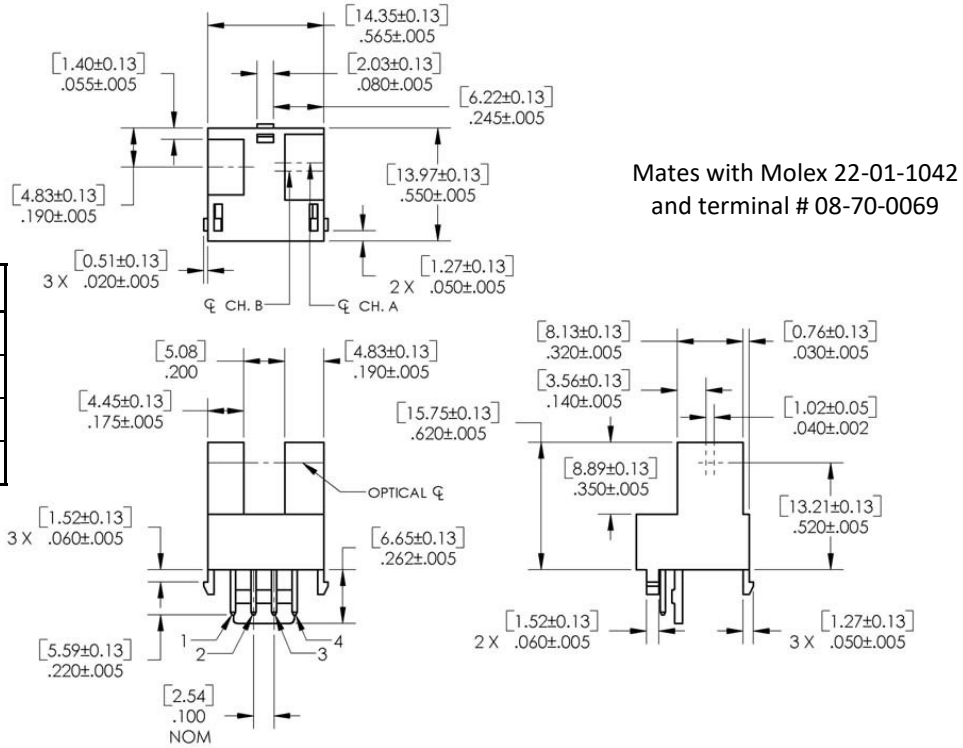

General Note

TT Electronics reserves the right to make changes in product specification without notice or liability. All information is subject to TT Electronics' own data and is considered accurate at time of going to print.

TT Electronics | OPTEK Technology
 2900 E. Plano Pkwy, Plano, TX 75074 | Ph: +1 972 323 2200
www.ttelectronics.com | sensors@ttelectronics.com

Looking for pricing, stock, or lifecycle information?

Click below to explore more details on WIN SOURCE:

 [View OPB950Z on WIN SOURCE](#)

 [TT Electronics](#) Information

Optimize Your Supply Chain with WIN SOURCE Solutions

-  Global Sourcing Solution
-  Obsolete Management
-  Cost Control Management
-  Shortage Management
-  Alternative Solution
-  Excess Inventory Management