



THE DATASHEET OF IPS511GTR



IPS511G/IPS512G

FULLY PROTECTED HIGH SIDE POWER MOSFET SWITCH

Features

- Over temperature protection (with auto-restart)
- Short-circuit protection (current limit)
- Active clamp
- E.S.D protection
- Status feedback
- Open load detection
- Logic ground isolated from power ground

Description

The IPS511G/IPS512G are fully protected five terminal high side switches with built in short-circuit, over-temperature, ESD protection, inductive load capability and diagnostic feedback. The output current is controlled when it reaches I_{lim} value. The current limitation is activated until the thermal protection acts. The over-temperature protection turns off the high side switch if the junction temperature exceeds $T_{shutdown}$. It will automatically restart after the junction has cooled 7°C below $T_{shutdown}$. A diagnostic pin is provided for status feedback of short-circuit, over-temperature and open load detection. The double level shifter circuitry allows large offsets between the logic ground and the load ground.

Product Summary

$R_{ds(on)}$	150m Ω (max)
V_{clamp}	50V
I Limit	5A
$V_{open\ load}$	3V

Truth Table

Op. Conditions	In	Out	Dg
Normal	H	H	H
Normal	L	L	L
Open load	H	H	H
Open load	L	H	H
Over current	H	L (limiting)	L
Over current	L	L	L
Over-temperature	H	L (cycling)	L
Over-temperature	L	L	L

Typical Connection

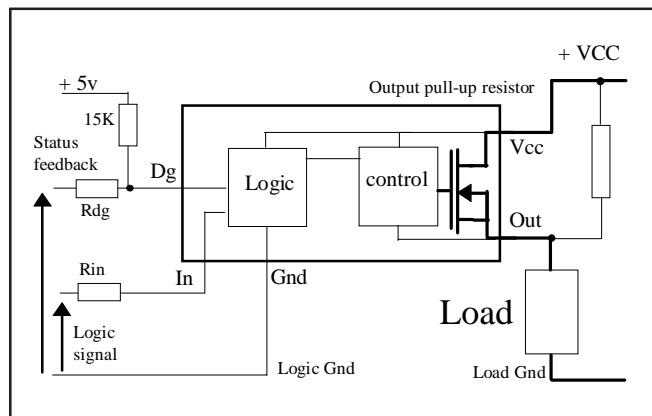

Available Package

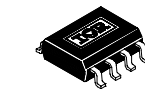

8 Lead SOIC
 (Single)
 IPS511G

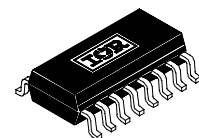

16 Lead SOIC
 (Dual)
 IPS512G

Absolute Maximum Ratings

Absolute maximum ratings indicate sustained limits beyond which damage to the device may occur. All voltage parameters are referenced to GROUND lead. ($T_j = 25^\circ\text{C}$ unless otherwise specified).

Symbol	Parameter	Min.	Max.	Units	Test Conditions
V_{out}	Maximum output voltage	$V_{CC}-50$	$V_{CC}+0.3$	V	
V_{offset}	Maximum logic ground to load ground offset	$V_{CC}-50$	$V_{CC}+0.3$		
V_{in}	Maximum Input voltage	-0.3	5.5		
$I_{in, max}$	Maximum IN current	-5	10	mA	
V_{dg}	Maximum diagnostic output voltage	-0.3	5.5	V	
$I_{dg, max}$	Maximum diagnostic output current	-1	10	mA	
$I_{sd cont.}$	Diode max. continuous current ⁽¹⁾ (IPS511G) (per leg/both legs ON - IPS512G)	—	1.4	A	
		—	0.8		
$I_{sd pulsed}$	Diode max. pulsed current ⁽¹⁾	—	10		
ESD1	Electrostatic discharge voltage (Human Body)	—	4000	V	C=100pF, R=1500Ω,
ESD2	Electrostatic discharge voltage (Machine Model)	—	500		C=200pF, R=0Ω, L=10μH
P_d	Maximum power dissipation ($r_{th}=125^\circ\text{C/W}$) IPS511G	—	1	W	
	($r_{th}=85^\circ\text{C/W}$, both legs on) IPS512G	—	1.5		
$T_j max.$	Max. storage & operating junction temp.	-40	+150	$^\circ\text{C}$	
$V_{vv max}$	Maximum Vcc voltage	—	50	V	

Thermal Characteristics

Symbol	Parameter	Min.	Typ.	Max.	Units	Test Conditions
R_{th1}	Thermal resistance with standard footprint	—	100	—	$^\circ\text{C/W}$	8 Lead SOIC
R_{th2}	Thermal resistance with 1" square footprint	—	80	—		
R_{th1} (2 mos on)	Thermal resistance with standard footprint (2 mosfets on)	—	85	—		16 Lead SOIC
R_{th2} (1) (1 mos on)	Thermal resistance with standard footprint (1 mosfet on)	—	100	—		
R_{th2} (2 mos on)	Thermal resistance with 1" square footprint (2 mosfets on)	—	50	—		

(1) Limited by junction temperature (pulsed current limited also by internal wiring)

Recommended Operating Conditions

These values are given for a quick design. For operation outside these conditions, please consult the application notes.

Symbol	Parameter	Min.	Max.	Units
V _{CC}	Continuous V _{CC} voltage	5.5	35	V
V _{IH}	High level input voltage	4	5.5	
V _{IL}	Low level input voltage	-0.3	0.9	
I _{out} T _{amb} =85°C	Continuous output current (T _{Ambient} = 85°C, T _j = 125°C, r _{th} = 100°C/W) IPS511G	—	1.4	A
I _{out} T _{amb} =85°C	Continuous output current per leg (T _{Ambient} = 85°C, T _j = 125°C R _{th} = 85°C/W both legs on) IPS512G	—	1.0	
R _{in}	Recommended resistor in series with IN pin	4	6	kΩ
R _{dg}	Recommended resistor in series with DG pin	10	20	

Static Electrical Characteristics

(T_j = 25°C, V_{CC} = 14V unless otherwise specified.)

Symbol	Parameter	Min.	Typ.	Max.	Units	Test Conditions
R _{ds(on)} @T _j =25°C	ON state resistance T _j = 25°C	—	130	150	mΩ	V _{in} = 5V, I _{out} = 2.5A
R _{ds(on)} (V _{CC} =6V)	ON state resistance @ V _{CC} = 6V	—	130	150		V _{in} = 5V, I _{out} = 1A
R _{ds(on)} @T _j =150°C	ON state resistance T _j = 150°C	—	220	—		V _{in} = 5V, I _{out} = 2.5A
V _{CC oper.}	Operating voltage range	5.5	—	35	V	
V _{clamp 1}	V _{CC} to OUT clamp voltage 1	50	56	—		I _d = 10mA (see Fig.1 & 2)
V _{clamp 2}	V _{CC} to OUT clamp voltage 2	—	58	65		I _d = I _{sd} (see Fig.1 & 2)
V _f	Body diode forward voltage	—	0.9	1.2		I _d = 2.5A, V _{in} = 0V
I _{CC off}	Supply current when OFF	—	16	50	μA	V _{in} = 0V, V _{out} = 0V
I _{CC on}	Supply current when ON	—	0.7	2	mA	V _{in} = 5V
I _{CC ac}	Ripple current when ON (AC RMS)	—	20	—	μA	V _{in} = 5V
V _{dg1}	Low level diagnostic output voltage	—	0.15	0.4	V	I _{dg} = 1.6 mA
I _{ol}	Output leakage current	—	60	120	μA	V _{out} = 6V
I _{ol}	Output leakage current	0	—	25		V _{out} = 0V
I _{dg leakage}	Diagnostic output leakage current	—	—	10		V _{dg} = 5.5V
V _{Ih}	IN high threshold voltage	—	2.3	2.5	V	
V _{Il}	IN low threshold voltage	1	2	—		
I _{in, on}	On state IN positive current	—	70	200	μA	V _{in} = 5V
I _{n, hyst.}	Input hysteresis	0.1	0.25	0.5	V	

IPS511G/IPS512G

Switching Electrical Characteristics

V_{CC} = 14V, Resistive Load = 5.6Ω, T_j = 25°C, (unless otherwise specified).

Symbol	Parameter	Min.	Typ.	Max.	Units	Test Conditions
T _{don}	Turn-on delay time	—	7	50	μs	See figure 3
T _{r1}	Rise time to V _{out} = V _{CC} - 5V	—	10	50		
T _{r2}	Rise time from the end of TR1 to V _{out} = 90% of V _{CC}	—	45	95		
dV/dt (on)	Turn ON dV/dt	—	1.3	4	V/μs	
E _{on}	Turn ON energy	—	400	—	μs	See figure 4
T _{doff}	Turn-off delay time	—	15	50		
T _f	Fall time to V _{out} = 10% of V _{CC}	—	10	50		
dV/dt (off)	Turn OFF dV/dt	—	2	6	V/μs	
E _{off}	Turn OFF energy	—	80	—	μJ	
T _{diag}	V _{out} to V _{diag} propagation delay	—	5	15	μs	

Protection Characteristics

Symbol	Parameter	Min.	Typ.	Max.	Units	Test Conditions
I _{lim}	Internal current limit	3	5	7	A	V _{out} = 0V
T _{sd+}	Over-temp. positive going threshold	—	165	—	°C	See fig. 2
T _{sd-}	Over-temp. negative going threshold	—	158	—	°C	See fig. 2
V _{sc}	Short-circuit detection voltage (3)	2	3	4	V	See fig. 2
V _{open load}	Open load detection threshold	2	3	4	V	

(3) Referenced to V_{CC}

Lead Assignments

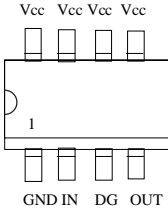
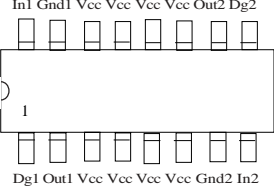
 <p>8 Lead SOIC</p>	 <p>16 Lead SOIC</p>
IPS511G	IPS512G
Part Number	

Functional Block Diagram

All values are typical

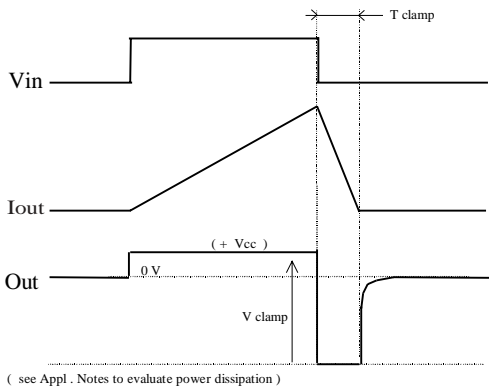
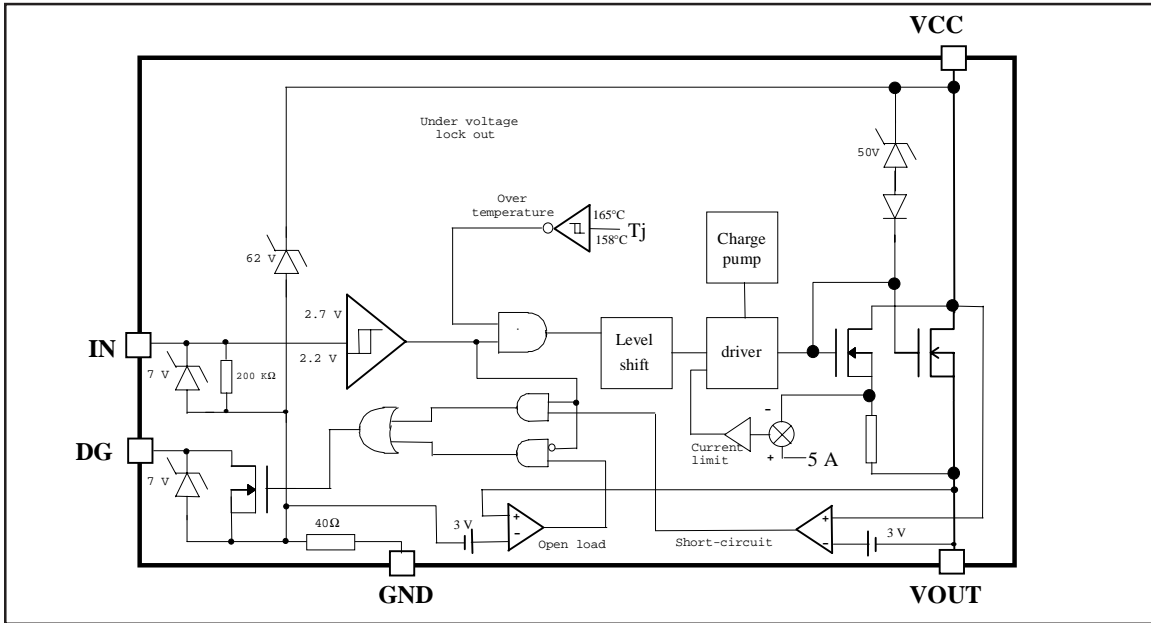

Figure 1 - Active clamp waveforms

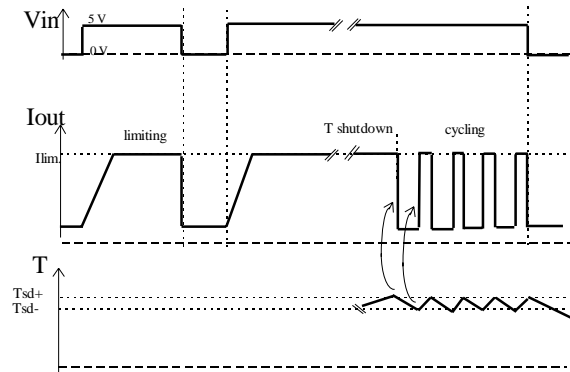

Figure 2 - Protection timing diagram

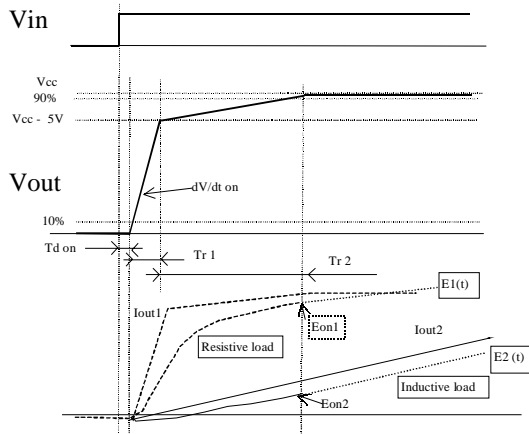

Figure 3 - Switching times definition (turn-on)
Turn on energy with a resistive or an inductive load

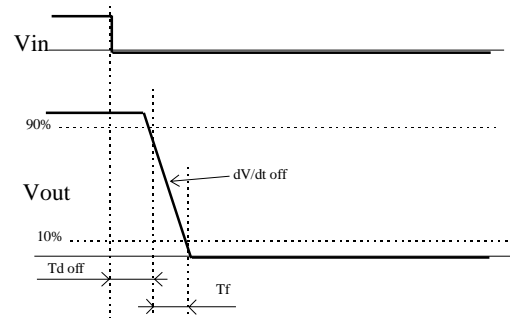

Figure 4 - Switching times definition (turn-off)

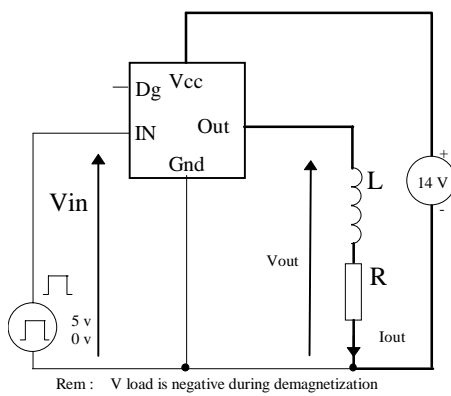

Figure 5 - Active clamp test circuit

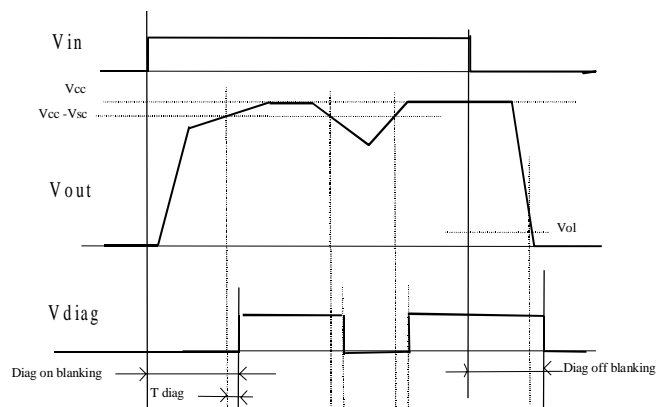

Figure 6 - Diagnostic delay definitions

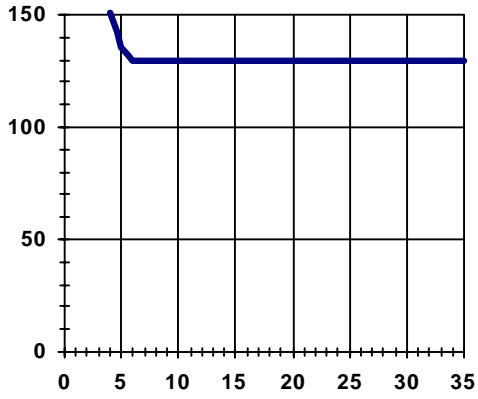

Figure 7 - R_{ds(on)} (mΩ) Vs V_{CC} (V)

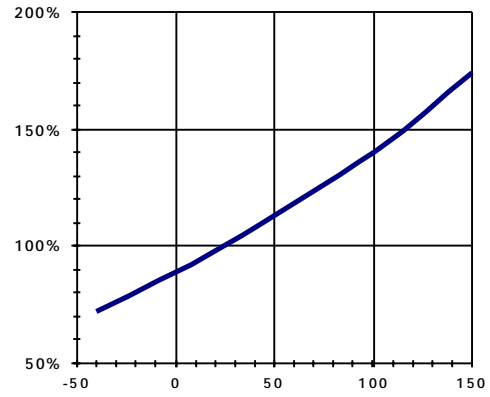

Figure 8 - Normalized R_{ds(on)} Vs T_j (°C)

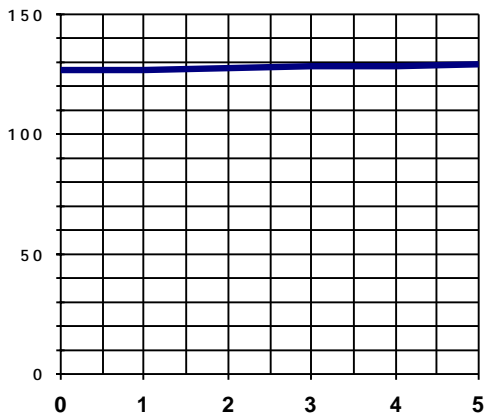

Figure 9 - R_{ds(on)} (mΩ) Vs I_{out} (A)

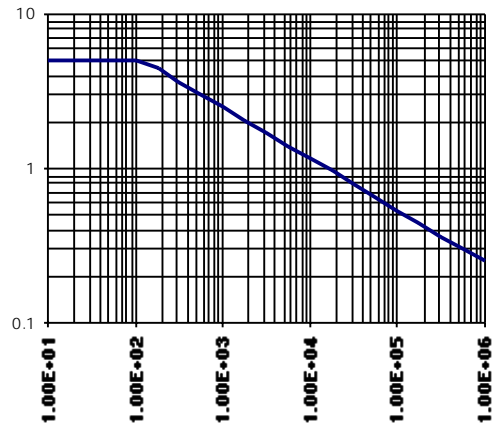

Figure 10 - Max. I_{out} (A) Vs Load Inductance (uH)

IPS511G/IPS512G

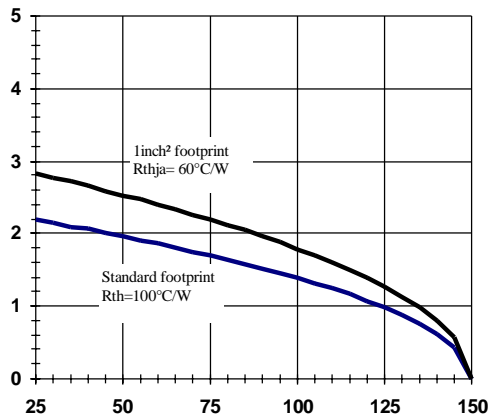

Figure 11a - Max load current (A) Vs Tamb (°C)
IPS511G

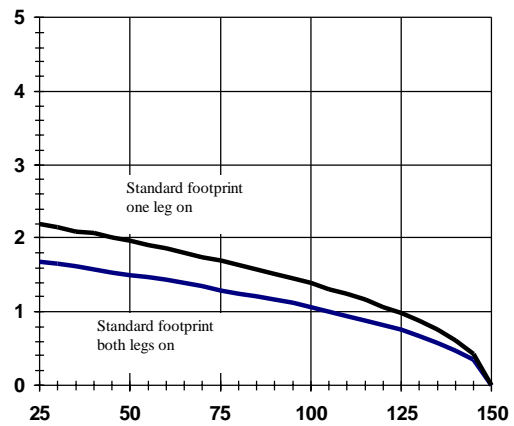

Figure 11b - Max load current (A) Vs Tamb (°C)
IPS512G

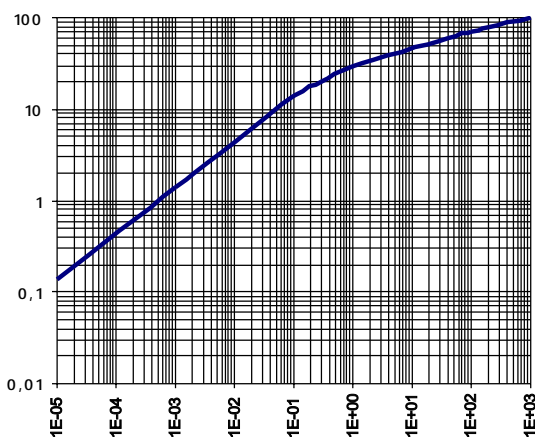

Figure 12 - Transient Thermal Impedance (°C/W)
Vs Time (S) - IPS511G/IPS512G

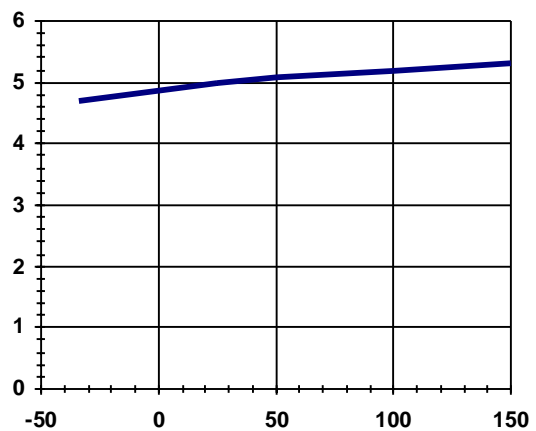

Figure 13 - Ilim (A) Vs Tj (°C)

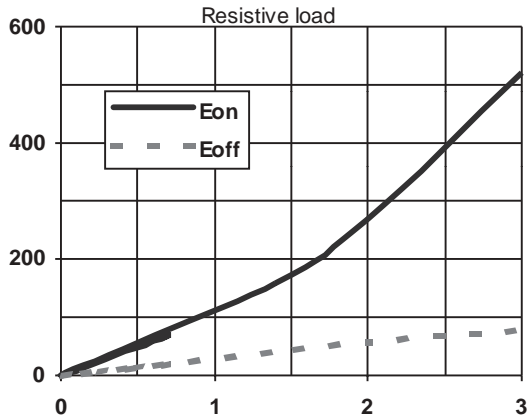

Figure 14 - E_{on} , E_{off} (μ J) vs I (A)

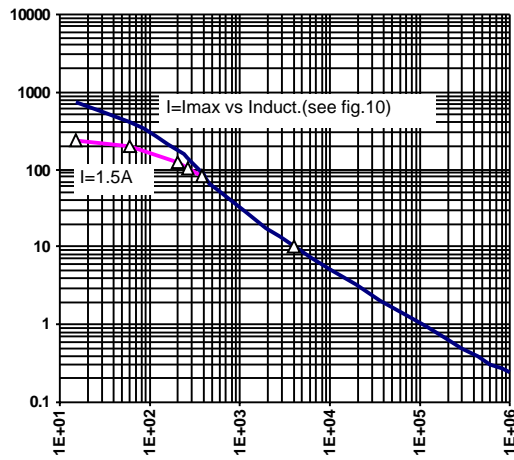

Figure 15 - E_{on} (μ J) Vs Load Inductance (μ H)
 (see Fig. 3)

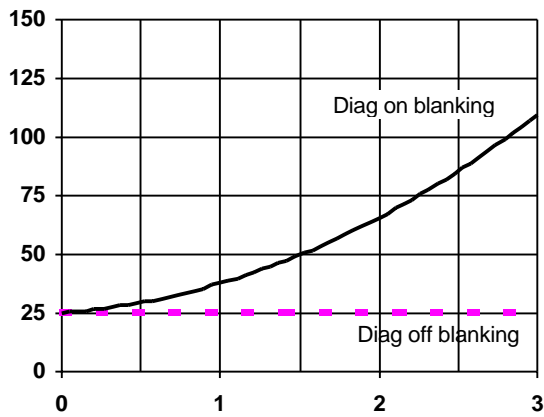

Figure 16 - Diag Blanking time (μ S) Vs I_{out} (A)
 (resistive load - see Fig. 6)

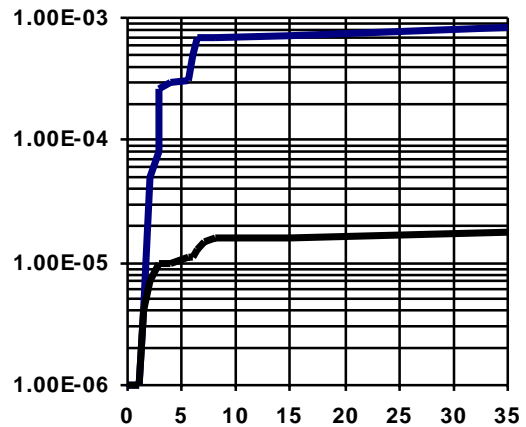
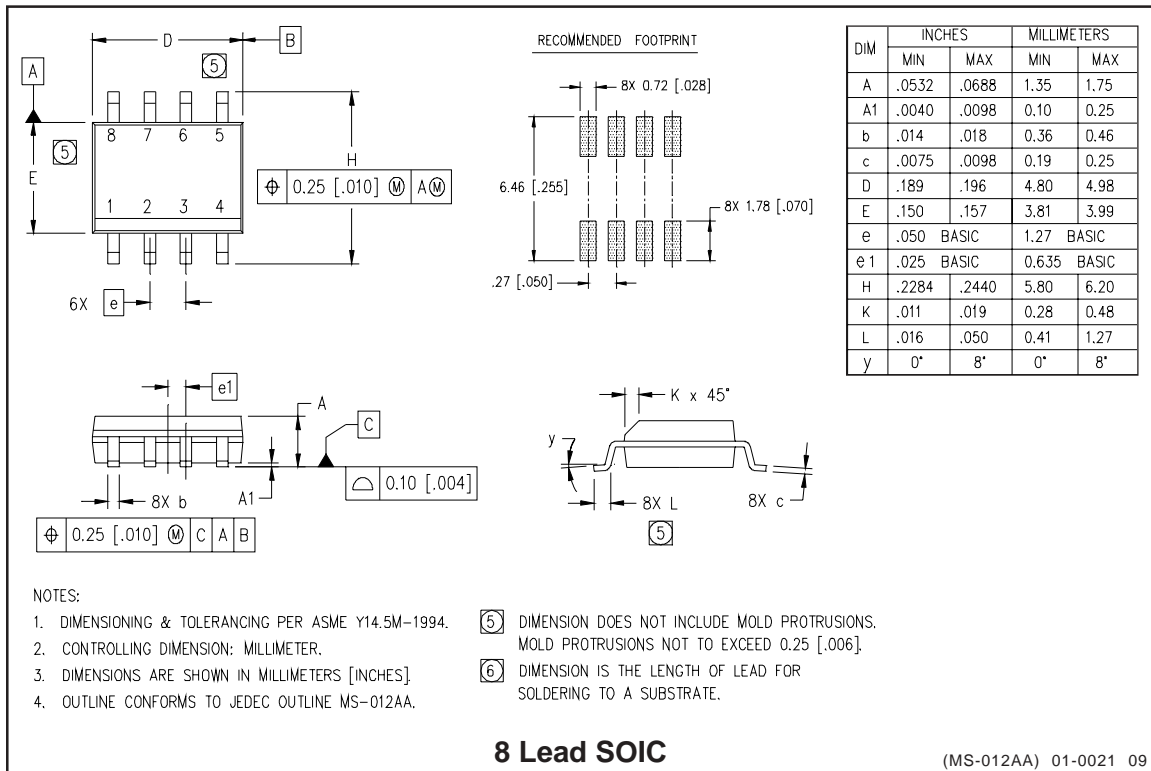

Figure 17 - I_{cc} (mA) Vs V_{cc} (V)

IPS511G/IPS512G

International
IR Rectifier

Case Outline - IPS511G



Case Outline

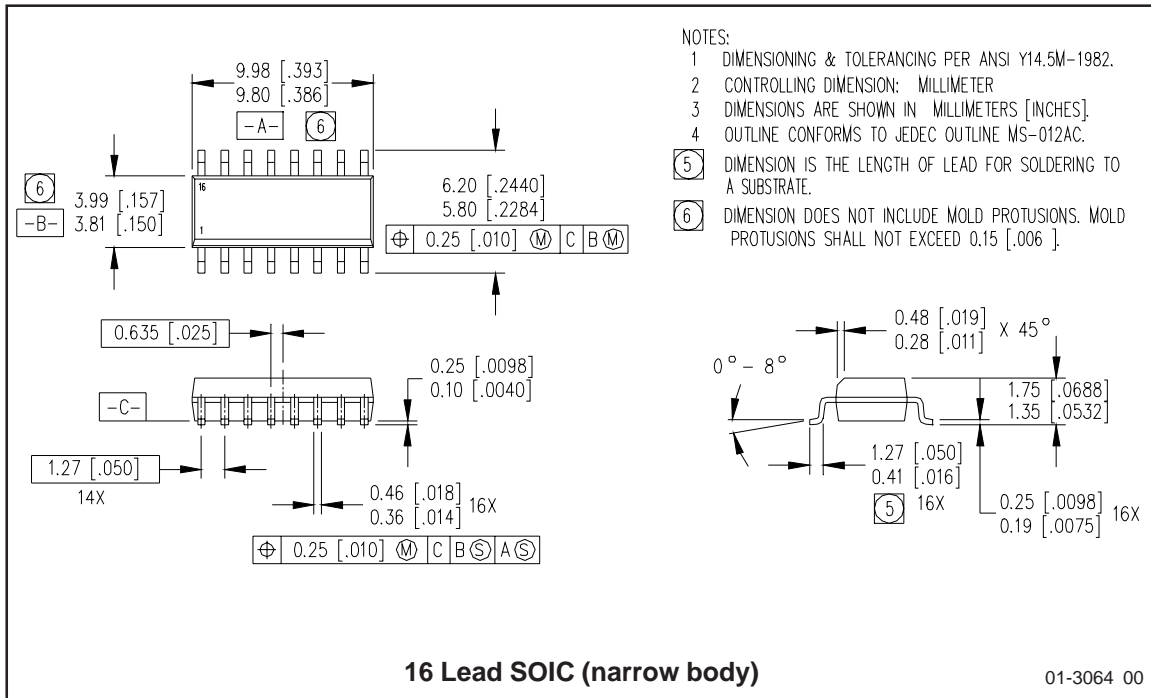

- NOTES:
- 1 DIMENSIONING & TOLERANCING PER ANSI Y14.5M-1982.
 - 2 CONTROLLING DIMENSION: MILLIMETER
 - 3 DIMENSIONS ARE SHOWN IN MILLIMETERS [INCHES].
 - 4 OUTLINE CONFORMS TO JEDEC OUTLINE MS-012AC.
 - 5 DIMENSION IS THE LENGTH OF LEAD FOR SOLDERING TO A SUBSTRATE.
 - 6 DIMENSION DOES NOT INCLUDE MOLD PROTUSIONS. MOLD PROTUSIONS SHALL NOT EXCEED 0.15 [.006].

Looking for pricing, stock, or lifecycle information?

Click below to explore more details on WIN SOURCE:

 [View IPS511GTR on WIN SOURCE](#)

 [Infineon Technologies](#) Information

Optimize Your Supply Chain with WIN SOURCE Solutions

-  Global Sourcing Solution
-  Obsolete Management
-  Cost Control Management
-  Shortage Management
-  Alternative Solution
-  Excess Inventory Management