



**THE DATASHEET OF
IR21571SPBF**



IR21571(S) & (PbF)

International
IR Rectifier

Absolute Maximum Ratings

Absolute maximum ratings indicate sustained limits beyond which damage to the device may occur. All voltage parameters are absolute voltages referenced to COM, all currents are defined positive into any lead. The thermal resistance and power dissipation ratings are measured under board mounted and still air conditions.

Symbol	Definition	Min.	Max.	Units
V _B	High side floating supply voltage	-0.3	625	V
V _S	High side floating supply offset voltage	V _B - 25	V _B + 0.3	
V _{HO}	High side floating output voltage	V _S - 0.3	V _B + 0.3	
V _{LO}	Low side output voltage	-0.3	V _{CC} + 0.3	
I _{OMAX}	Maximum allowable output current (either output) due to external power transistor miller effect	-500	500	mA
I _{RT}	R _T pin current	-5	5	V
V _{CT}	C _T pin voltage	-0.3	5.5	
V _{DC}	V _{DC} pin voltage	-0.3	V _{CC} + 0.3	
I _{CPH}	CPH pin current	-5	5	mA
I _{RPH}	RPH pin current	-5	5	
I _{RUN}	RUN pin current	-5	5	
I _{DT}	Deadtime pin current	-5	5	
V _{CS}	Current sense pin voltage	-0.3	5.5	V
I _{CS}	Current sense pin current	-5	5	mA
I _{OC}	Over-current threshold pin current	-5	5	
I _{SD}	Shutdown pin current	-5	5	
I _{CC}	Supply current (note 1)	-20	20	
dV/dt	Allowable offset voltage slew rate	-50	50	V/ns
P _D	Package power dissipation @ T _A ≤ +25°C (16 lead PDIP)	—	1.60	W
	P _D = (T _{JMAX} -T _A)/R _{thJA} (16 lead SOIC)	—	1.00	
R _{thJA}	Thermal resistance, junction to ambient (16 lead PDIP)	—	75	°C/W
	(16 lead SOIC)	—	115	
T _J	Junction temperature	-55	150	°C
T _S	Storage temperature	-55	150	
T _L	Lead temperature (soldering, 10 seconds)	—	300	

Note 1: This IC contains a zener clamp structure between the chip V_{CC} and COM which has a nominal breakdown voltage of 15.6V. Please note that this supply pin should not be driven by a DC, low impedance power source greater than the V_{CLAMP} specified in the Electrical Characteristics section.

Recommended Operating Conditions

For proper operation the device should be used within the recommended conditions.

Symbol	Definition	Min.	Max.	Units
V _{BS}	High side floating supply voltage	V _{CC} - 0.7	V _{CLAMP}	V
V _S	Steady state high side floating supply offset voltage	-3.0	600	
V _{CC}	Supply voltage	V _{CCUV+}	V _{CLAMP}	
I _{CC}	Supply current	Note 2	10	mA
V _{DC}	V _{DC} lead voltage	0	V _{CC}	V
C _T	C _T lead capacitance	220	—	pF
R _{DT}	Deadtime resistance	1.0	—	
R _{OC}	Over-current (CS+) threshold programming resistance	—	50	
I _{RT}	R _T lead current (Note 3)	-500	-50	uA
I _{RPH}	RPH lead current (Note 3)	0	450	
I _{RUN}	RUN lead current (Note 3)	0	450	
I _{SD}	Shutdown lead current	-1	1	mA
I _{CS}	Current sense lead current	-1	1	
T _J	Junction temperature	-40	125	°C
V _{BSMIN}	Minimum required VBS voltage for proper HO functionality	—	5	V

Electrical Characteristics

V_{CC} = V_{BS} = V_{BIAS} = 14V +/- 0.25V, R_T = 40.0kΩ, C_T = 470 pF, RPH and RUN leads no connection, V_{CPH} = 0.0V, R_{DT} = 6.1kΩ, R_{OC} = 20.0kΩ, V_{CS} = 0.5V, V_{SD} = 0.0V, C_L = 1000pF, T_A = 25°C unless otherwise specified.

Supply Characteristics						
Symbol	Definition	Min.	Typ.	Max.	Units	Test Conditions
V _{CCUV+}	V _{CC} supply undervoltage positive going threshold	10.5	11.4	12.4	V	V _{CC} rising from 0V
V _{UVHYS}	V _{CC} supply undervoltage lockout hysteresis	1.5	1.8	2.2		
I _{QCCUV}	UVLO mode quiescent current	50	150	300	μA	V _{CC} < V _{CCUV-}
I _{QCCFLT}	Fault-mode quiescent current	75	200	300		SD=5V, CS = 2V or T _J > T _{SD}
I _{QCC}	Quiescent V _{CC} supply current	2.9	3.8	4.3	mA	R _T no connection, C _T connected to COM
I _{CC50K}	V _{CC} supply current, f= 50kHz	4.0	5.5	7.0		R _T = 36kΩ, R _{DT} = 5.6kΩ, C _T = 220pF
V _{CLAMP}	V _{CC} zener clamp voltage	14.5	15.6	16.5	V	I _{CC} = 10mA

Note 2: Enough current should be supplied into the VCC lead to keep the internal 15.6V zener clamp diode on this lead regulating its voltage.

Note 3: Due to the fact that the RT input is a voltage-controlled current source, the total RT lead current is the sum of all the parallel current sources connected to that lead. For optimum oscillator current mirror performance, this total current should be kept between 50μA and 500μA. During the preheat mode, the total current flowing out of the RT lead consists of the RPH lead current plus the current due to the RT resistor. During the run mode, the total RT lead current consists of the RUN lead current plus the current due to the RT resistor.

IR21571(S) & (PbF)

International
IR Rectifier

Electrical Characteristics (cont.)

$V_{CC} = V_{BS} = V_{BIAS} = 14V \pm 0.25V$, $R_T = 40.0k\Omega$, $C_T = 470 \text{ pF}$, RPH and RUN leads no connection, $V_{CPH} = 0.0V$, $R_{DT} = 6.1k\Omega$, $R_{OC} = 20.0k\Omega$, $V_{CS} = 0.5V$, $V_{SD} = 0.0V$, $C_L = 1000pF$, $T_A = 25^\circ C$ unless otherwise specified.

Floating Supply Characteristics						
Symbol	Definition	Min.	Typ.	Max.	Units	Test Conditions
I_{QBS0}	Quiescent V_{BS} supply current	0	0	15	μA	$V_{HO} = V_S$
I_{QBS1}	Quiescent V_{BS} supply current	5	35	65		$V_{HO} = V_B$
I_{LK}	Offset supply leakage current	—	—	50	μA	$V_B = V_S = 600V$
Oscillator I/O Characteristics						
Symbol	Definition	Min.	Typ.	Max.	Units	Test Conditions
fosc	Oscillator frequency	45.5	48	50.5	kHz	$R_T = 16.9k\Omega$, $R_{DT} = 6.1k\Omega$, $C_T = 470pF$
d	Oscillator duty cycle	49.5	50	50.5	%	
VCT+	Upper C_T ramp voltage threshold	3.7	4.0	4.3	V	
VCT-	Lower C_T ramp voltage threshold	1.85	2.0	2.15		
VCTFLT	Fault-mode C_T lead voltage	—	0	50	mV	$SD = 5V$, $CS = 2V$, or $T_j > T_{SD}$
VRT	R_T lead voltage	1.85	2.0	2.15	V	
VRTFLT	Fault-mode R_T lead voltage	—	0	50	mV	$SD = 5V$, $CS = 2V$, or $T_j > T_{SD}$
tdlo	LO output deadtime	2	2.3	2.5	μsec	
tdho	HO output deadtime	2	2.3	2.5		
Preheat Characteristics						
Symbol	Definition	Min.	Typ.	Max.	Units	Test Conditions
I_{CPH}	CPH lead charging current	0.72	0.85	0.98	μA	$V_{CPH} = 5.3V$
V_{CPHIGN}	CPH lead Ignition mode threshold voltage	3.7	4.0	4.3	V	
V_{CPHRUN}	CPH lead run mode threshold voltage	4.7	5.15	5.45		
$V_{CPHCLMP}$	CPH lead clamp voltage	9.0	9.5	10.5	mV	$I_{CPH} = 1mA$
V_{CPHFLT}	Fault-mode CPH lead voltage	—	0	300		$SD = 5V$, $CS = 2V$, or $T_j > T_{SD}$
RPH Characteristics						
Symbol	Definition	Min.	Typ.	Max.	Units	Test Conditions
I_{RPHLK}	Open circuit RPH lead leakage current	—	0.01	0.1	μA	$V_{RPH} = 5V$, $V_{RPH} = 6V$
V_{RPHFLT}	Fault-mode RPH lead voltage	—	0	50	mV	$SD = 5V$, $CS = 2V$, or $T_j > T_{SD}$

Electrical Characteristics (cont.)

$V_{CC} = V_{BS} = V_{BIAS} = 14V \pm 0.25V$, $R_T = 40.0k\Omega$, $C_T = 470 \text{ pF}$, RPH and RUN leads no connection, $V_{CPH} = 0.0V$, $R_{DT} = 6.1k\Omega$, $R_{OC} = 20.0k\Omega$, $V_{CS} = 0.5V$, $V_{SD} = 0.0V$, $C_L = 1000\text{pF}$, $T_A = 25^\circ\text{C}$ unless otherwise specified.

RUN Characteristics						
Symbol	Definition	Min.	Typ.	Max.	Units	Test Conditions
IRUNLK	Open circuit RUN lead leakage current	—	0.01	0.1	μA	$V_{RUN} = 5V$
V _{RUNFLT}	Fault-mode RUN lead voltage	—	0	50	mV	SD = 5V, CS = 2V, or $T_j > T_{SD}$
Protection Circuitry Characteristics						
Symbol	Definition	Min.	Typ.	Max.	Units	Test Conditions
V _{SD+}	Rising shutdown lead threshold voltage	1.9	2.1	2.3	V	
V _{SDHYS}	Shutdown pin threshold hysteresis	100	150	200	mV	
V _{CS+}	Over-current sense threshold voltage	0.99	1.10	1.21	V	
V _{CS-}	Under-current sense threshold voltage	0.15	0.2	0.26		
T _{CS}	Over-current sense propagation delay	100	250	400	nsec	Delay from CS to LO
V _{DC+}	Low V_{BUS} /rectified line input upper threshold	5.0	5.20	5.6	V	
V _{DC-}	Low V_{BUS} /rectified line input lower threshold	2.85	3.3	3.3		
T _{SD}	Thermal shutdown junction temperature	150	160	170	$^\circ\text{C}$	Note 4
Gate Driver Output Characteristics						
Symbol	Definition	Min.	Typ.	Max.	Units	Test Conditions
V _{OL}	Low-level output voltage	—	0	100	mV	$I_o = 0$
V _{OH}	High level output voltage	—	0	100		$V_{BIAS} - V_O, I_o = 0$
t _r	Turn-on rise time	55	85	150	nsec	
t _f	Turn-off fall time	35	45	100		

Note 4: When the IC senses an overtemperature condition ($T_j > 160^\circ\text{C}$), the IC is latched off. In order to reset this Fault Latch, the SD lead must be cycled high and then low, or the V_{CC} supply to the IC must be cycled below the falling undervoltage lockout threshold (V_{CCUV-}).

IR21571(S) & (PbF)

International
IR Rectifier

Functional Block Diagram

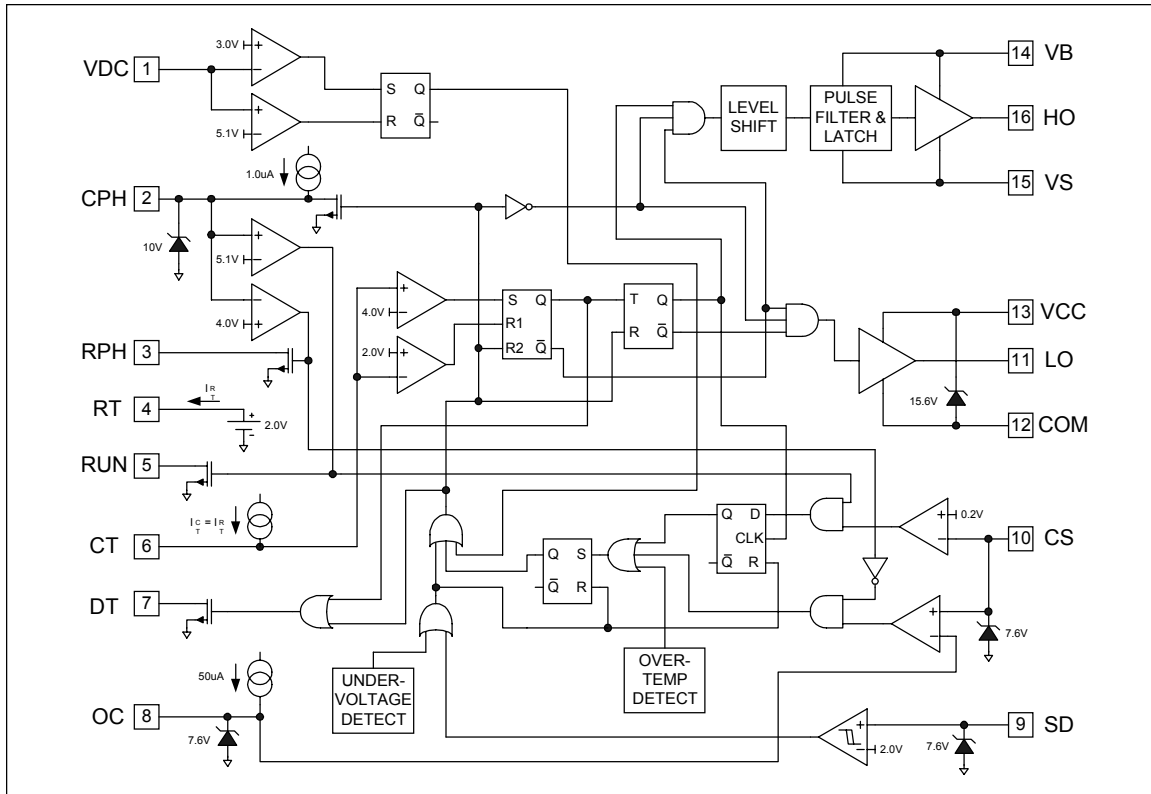

Lead Assignments & Definitions

Pin #	Symbol	Description
1	VDC	DC Bus Sensing Input
2	CPH	Preheat Timing Capacitor
3	RPH	Preheat Frequency Resistor & Ignition Capacitor
4	RT	Oscillator Timing Resistor
5	RUN	Run Frequency Resistor
6	CT	Oscillator Timing Capacitor
7	DT	Deadtime Programming
8	OC	Over-current (CS+) Threshold Programming
9	SD	Shutdown Input
10	CS	Current Sensing Input
11	LO	Low-Side Gate Driver Output
12	COM	IC Power & Signal Ground
13	VCC	Logic & Low-Side Gate Driver Supply
14	VB	High-Side Gate Driver Floating Supply
15	VS	High Voltage Floating Return
16	HO	High-Side Gate Driver Output

IR21571 State Diagram

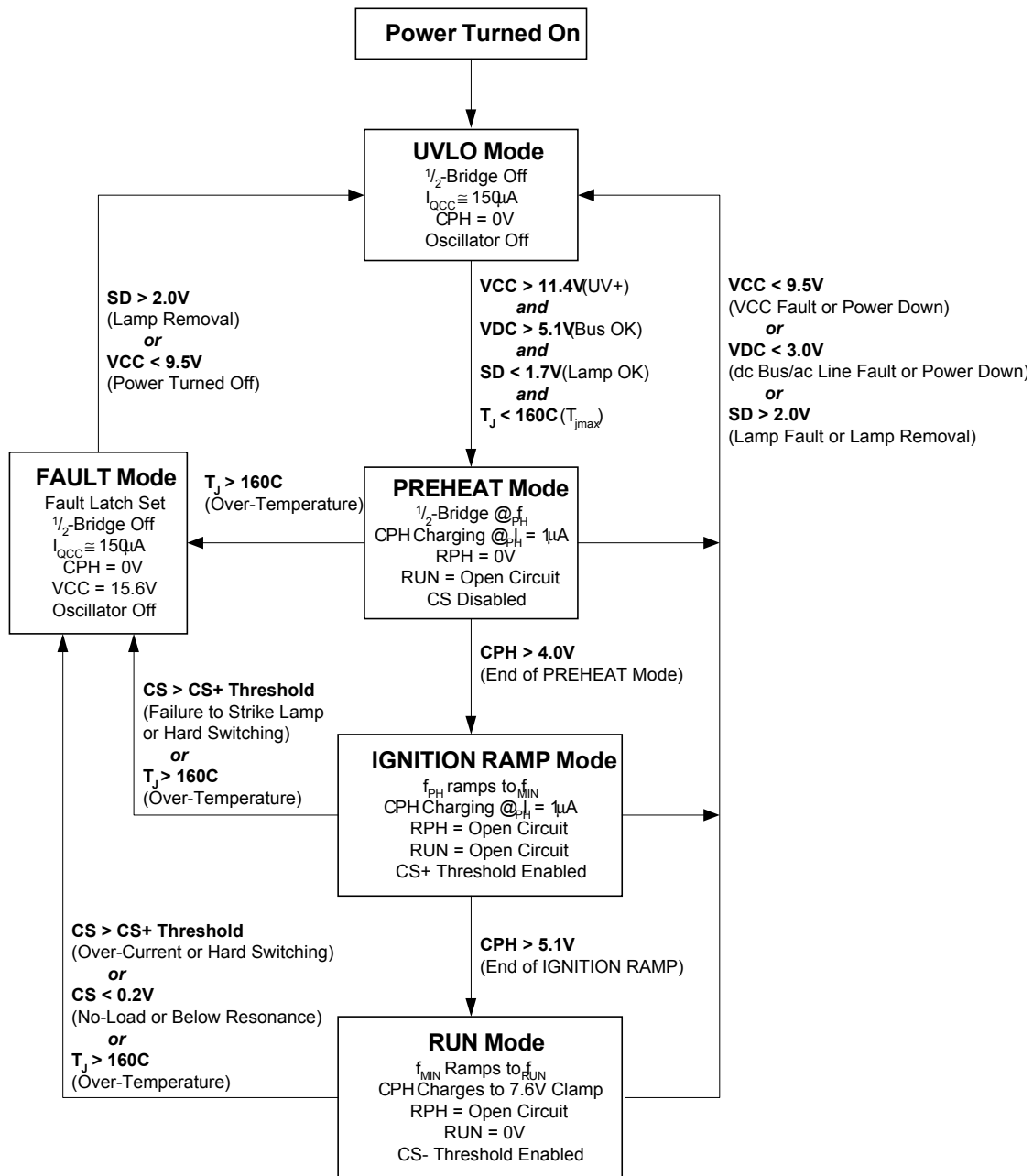

Description of Operation & Component Selection Tips

Supply Bypassing and PC Board Layout Rules

Component selection and placement on the pc board is extremely important when using power control ICs. Vcc should be bypassed to COM as close to the IC terminals as possible with a low ESR/ESL capacitor, as shown in Figure 1 below.

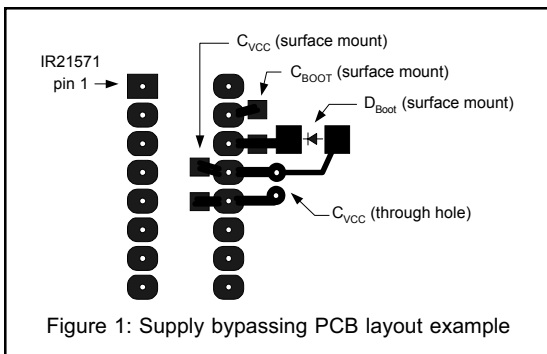

Figure 1: Supply bypassing PCB layout example

A rule of thumb for the value of this bypass capacitor is to keep its minimum value at least 2500 times the value of the total input capacitance (C_{iss}) of the power transistors being driven. This decoupling capacitor can be split between a higher valued electrolytic type and a lower valued ceramic type connected in parallel, although a good quality electrolytic (e.g., $10\mu\text{F}$) placed immediately adjacent to the Vcc and COM terminals will work well.

In a typical application circuit, the supply voltage to the IC is normally derived by means of a high value startup resistor ($1/4\text{W}$) from the rectified line voltage, in combination with a charge pump from the output of the half-bridge. With this type of supply arrangement, the internal 15.6V zener clamp diode from Vcc to COM will determine the steady state IC supply voltage.

Connecting the IC Ground (COM) to the Power Ground

Both the low power control circuitry and low side gate driver output stage grounds return to this lead within the IC. The COM lead should be connected to the bottom terminal of the current sense resistor in the source of the low side power MOSFET using an individual pc board trace, as shown in Figure 2. In addition, the ground return path of the timing components and Vcc decoupling capacitor should be connected directly to the IC COM lead, and not via separate traces or jumpers to other ground traces on the board.

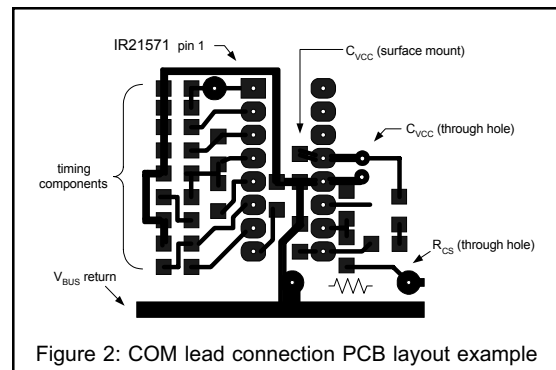
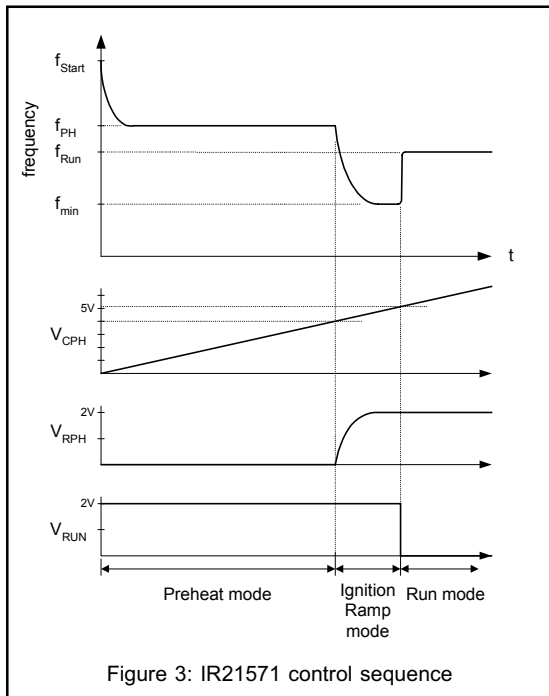

Figure 2: COM lead connection PCB layout example

This connection technique prevents high current ground loops from interfering with the sensitive timing component operation, and allows the entire control circuit to reject common-mode noise due to output switching.

The Control Sequence & Timing Component Selection

The IR21571 uses the following control sequence (Figure 3) to drive rapid start fluorescent lamps.



The control sequence used in the IR21571 allows the Run Mode operating frequency of the ballast to be higher than the ignition frequency (i.e., $f_{start} > f_{ph} > f_{run} > f_{ign}$). This control sequence is recommended for lamp types where the ignition frequency is too close to the run frequency to ensure proper lamp striking for all production resonant LC component tolerances (please note that it is possible to use the IR21571 in systems where $f_{start} > f_{ph} > f_{ign} > f_{run}$, simply by leaving the RUN lead open).

Six leads in the IC are used to control the **Startup**, **Preheat**, **Ignition Ramp**, and **Run** modes of operation, and to allow ballast and lamp engineers the flexibility to optimize their designs for virtually any lamp type.

The heart of this controller is an oscillator which resembles those found in many popular PWM voltage regulator ICs. In its simplest form, this oscillator consists of a timing resistor and capacitor connected to ground. The voltage across the timing capacitor C_T is a sawtooth, where the rising portion of the ramp is determined by the current in the R_T lead, and the falling portion of the ramp is determined by an external deadtime resistor R_{DT} . The oscillograph in Figure 4 illustrates the relationship between the oscillator capacitor waveform and the gate driver outputs.

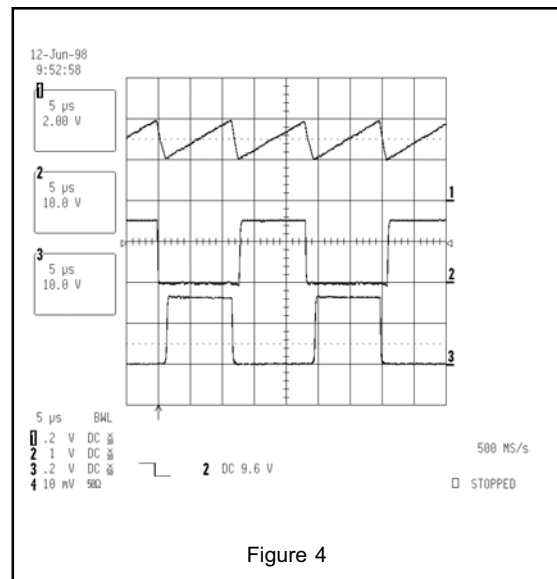

The deadtime can be programmed by means of the external R_{DT} resistor, given a certain range of C_T capacitor values, using the graph shown in Figure 5.

The R_T input is a voltage-controlled current source, where the voltage is regulated to be approximately 2.0V. In order to maintain proper linearity between the R_T lead current and the C_T capacitor charging current, the value of the R_T lead current should be kept between $50\mu A$ and $500\mu A$. The R_T lead can also be used as a feedback point for closed loop control.

IR21571(S) & (PbF)

International
IR Rectifier

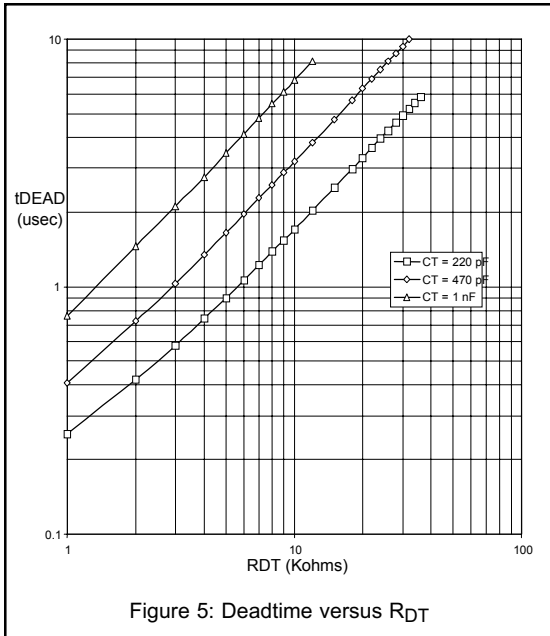

During the **Startup Mode**, the operating frequency is determined by the parallel combination of R_{PH} , R_{START} , and R_T , combined with the values of C_{START} , C_T and R_{DT} , as shown in Figure 6. This frequency is normally chosen to ensure that the instantaneous voltage across the lamp during the first few cycles of operation does not exceed the strike potential of the lamp. As the voltage across C_{START} charges up to the R_T lead voltage, the output frequency exponentially decays to the preheat frequency.

During the Preheat Mode, the operating frequency is determined by the parallel combination of R_{PH} and R_T , combined with the value of C_T and R_{DT} . This frequency, along with the Preheat Time, is normally chosen to ensure that adequate heating of the lamp filaments occur. Typically, a 4.5:1 ratio of the hot filament-to-cold filament resistance is desired for maximum lamp life, as shown in Figure 7.

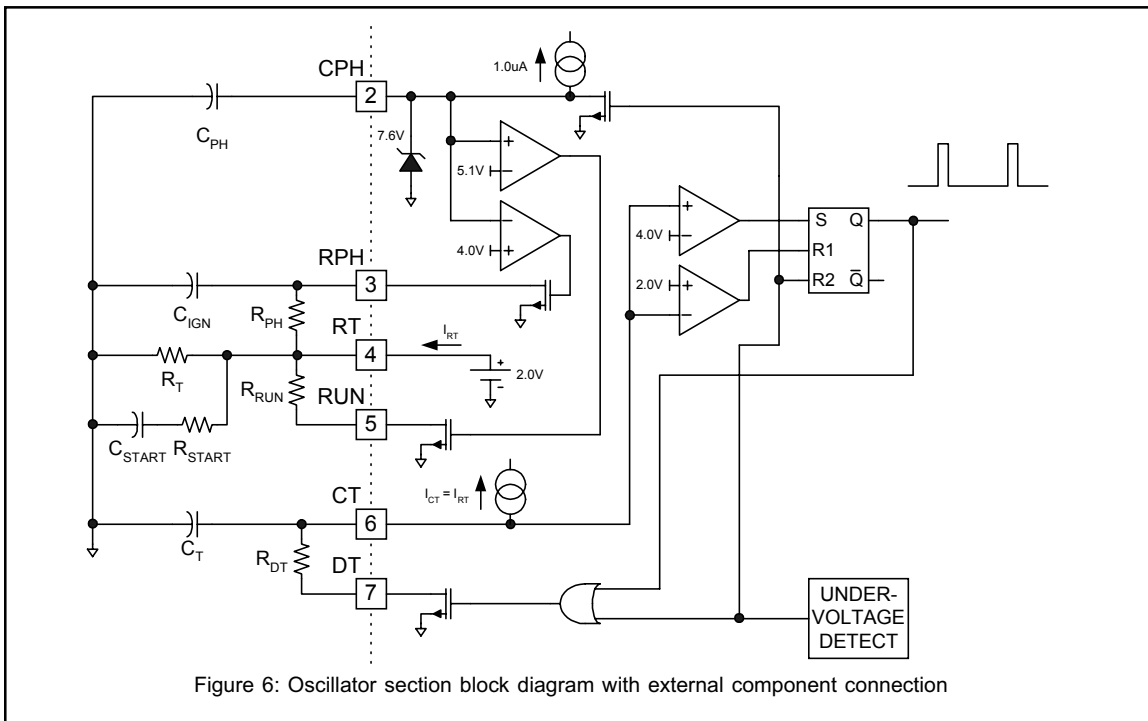

IR21571(S) & (PbF)

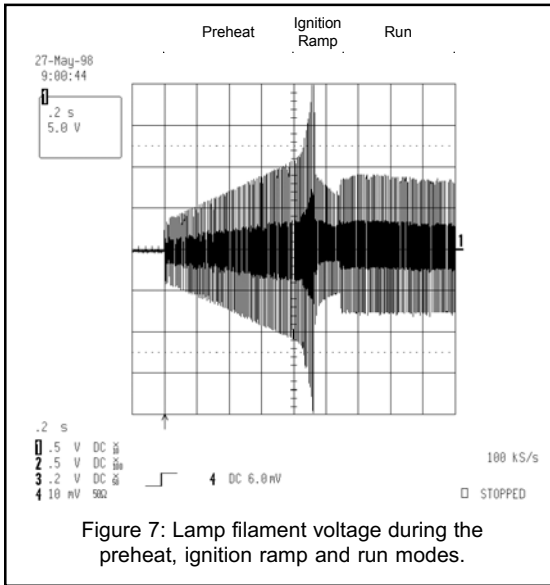

The Preheat Time is programmed by means of the preheat capacitor, C_{PH} , an internal $1\mu A$ current source, and an internal threshold on the C_{PH} lead of 4.0V, according to the following formula:

$$t_{PH} = 4.7E6 \cdot C_{PH}, \quad \text{or}$$

$$C_{PH} = 213E-9 \cdot t_{PH}$$

At the end of the Preheat Time, the internal, open-drain transistor holding the R_{PH} lead to ground turns off, and the voltage on this lead charges exponentially up to the R_T lead potential. During this Ignition Ramp Mode, the output frequency exponentially decays to a minimum value. The rate of decay of this frequency is a function of the $R_{PH} \cdot C_{PH}$ time constant. Because the Ignition Ramp Mode ends when the voltage on the C_{PH} lead reaches 5.15V, the Ignition Ramp Mode is always 1/4th as long as the preheat time. When the C_{PH} lead reaches 5.15V, an open-drain transistor on the RUN lead turns on, and the external R_{RUN} resistor is then in parallel with the R_T resistor. The Run Mode operating frequency is therefore a function of the parallel combination of R_{RUN} and R_T , and this means that the operating power of the lamp can be programmed by means of R_{RUN} .

The following graphs, Figures 8 and 9, illustrate the relationship between the effective R_T resistance (i.e., the parallel combination of resistors which programs the C_T capacitor charging current) and the operating frequency.

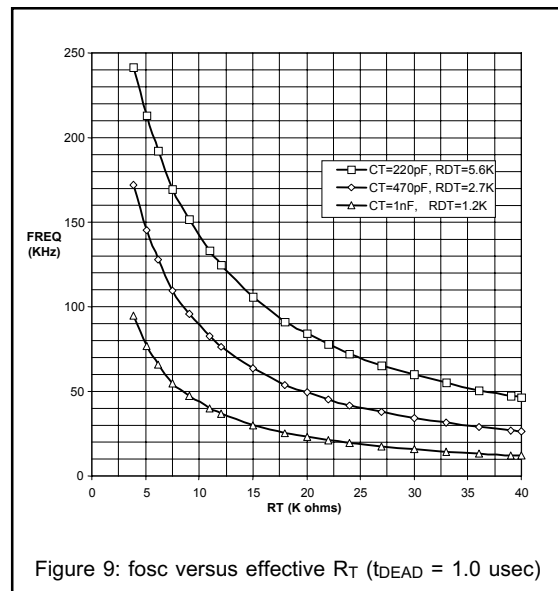
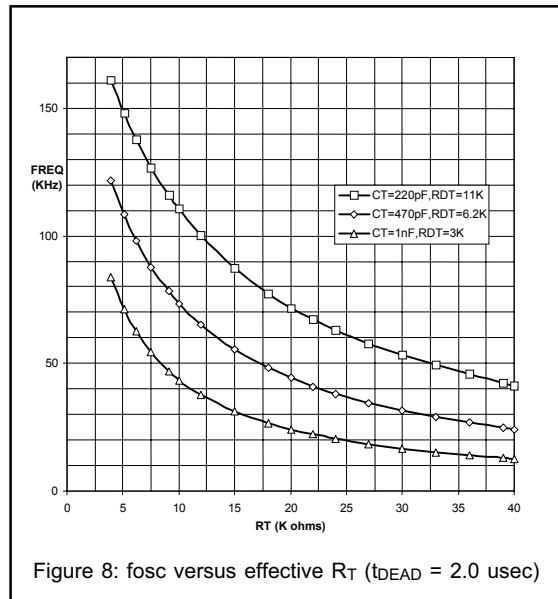

IR21571(S) & (PbF)

Thus, for a lamp removal and replacement, the ballast automatically restarts the lamp in the proper manner, maximizing lamp life and minimizing stress on the power MOSFETs or IGBTs. The SD lead contains an internal 7.5V zener diode clamp, thereby reducing the number of external components required.

Half-Bridge Current Sensing and Protection

The third lead used for protection is the CS lead, which is normally connected to a resistor in the source of the lower power MOSFET, as shown in Figure 14.

The CS lead is used to sense fault conditions such as failure of a lamp to strike, over-current during normal operation, hard switching, no load, and operation below resonance. If any one of these conditions is sensed, the fault latch is set, the oscillator is disabled, the gate driver outputs go low, and the chip is put into the micropower mode. The CS lead performs its sensing functions on a cycle-by-cycle basis in order to maximize ballast reliability.

For the over-current, failure-to-strike, and hard switching fault conditions, an externally programmable, positive-going CS+ threshold is

enabled at the end of the preheat time. The level of this positive-going threshold is determined by the value of the resistor ROC. The value of the resistor ROC is determined by the following formula:

$$R_{OC} = \frac{V_{CS+}}{50E - 6} \text{ or}$$

$$V_{CS+} = 50E - 6 - R_{OC}$$

For the under-current and under-resonance conditions, there is a negative-going CS- threshold of 0.2V which is enabled at the onset of the run mode. The sensing of this CS- threshold is synchronized with the falling edge of the LO output.

Figures 15, 16 and 17 are oscillographs of fault conditions. Figure 15 shows a failure of the lamp to strike, Figure 16 shows a hard switching condition and Figure 17 shows an under-current condition.

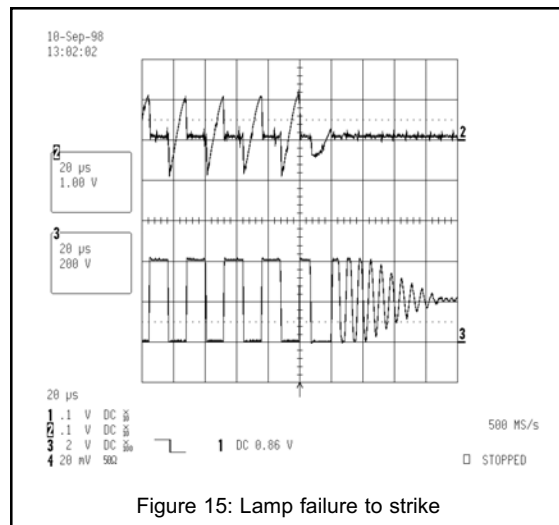
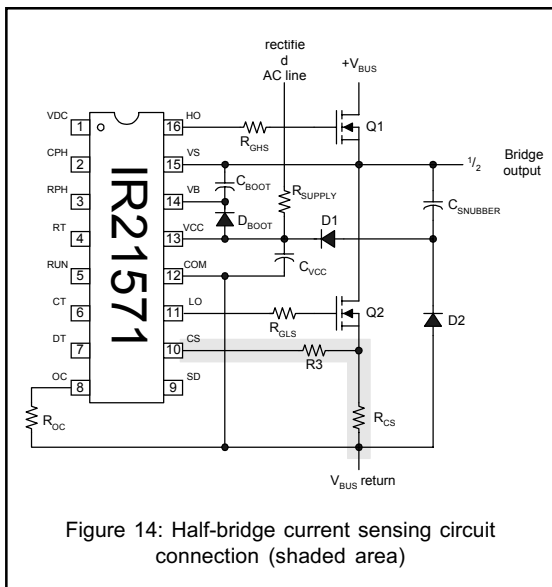

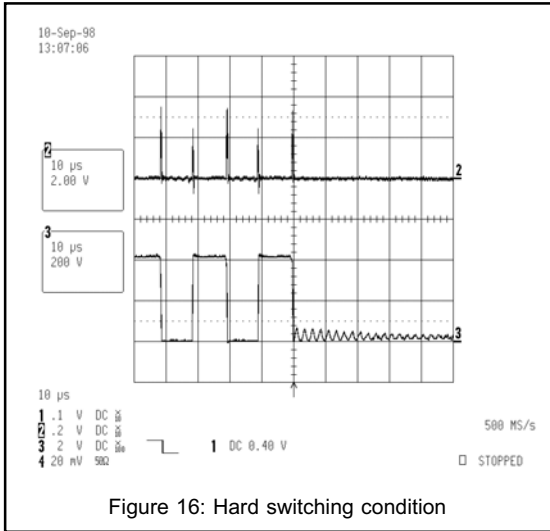

Figure 16: Hard switching condition

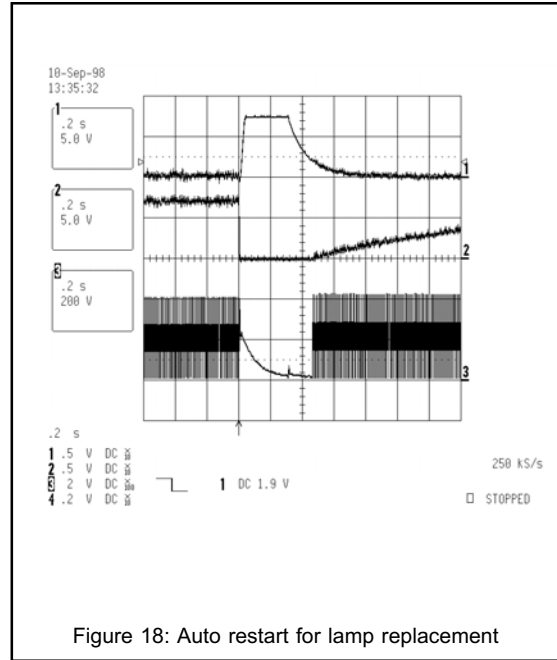

Figure 18: Auto restart for lamp replacement

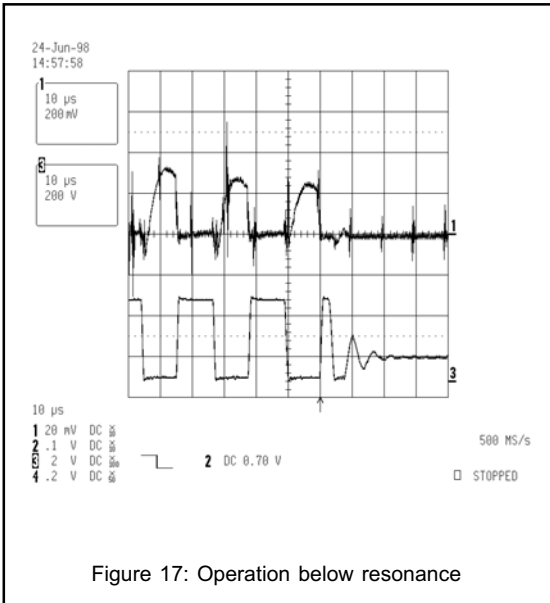

Figure 17: Operation below resonance

Recovery from such a fault condition is accomplished by cycling either the SD lead or the V_{CC} lead. When a lamp is removed, the SD lead goes high, the fault latch is reset, and the chip is held off in an unlatched state. Lamp replacement causes the SD lead to go low again, reinitiating the startup sequence. The fault latch can also be reset by the undervoltage lockout signal, if V_{CC} falls below the lower undervoltage threshold.

Bootstrap Supply Considerations

Power is normally supplied to the high-side circuitry by means of a simple charge pump from V_{CC} , as shown in Figure 19.

IR21571(S) & (PbF)

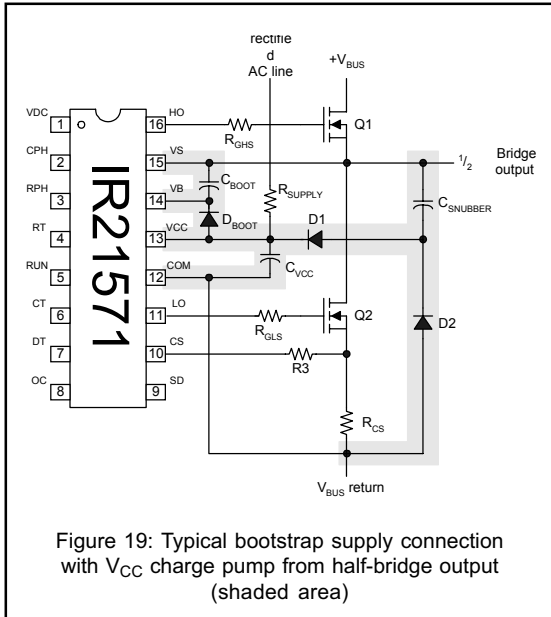

A high voltage, fast recovery diode D_{BOOT} (the so-called bootstrap diode) is connected between V_{CC} (anode) and VB (cathode), and a capacitor C_{BOOT} (the so-called bootstrap capacitor) is connected between the VB and VS leads. During half-bridge switching, when MOSFET Q2 is on and Q1 is off, the bootstrap capacitor C_{BOOT} is charged from the V_{CC} decoupling capacitor, through the bootstrap diode D_{BOOT}, and through Q2. Alternately, when Q2 is off and Q1 is on, the bootstrap diode is reverse-biased, and the bootstrap capacitor (which 'floats' on the source of the upper power MOSFET) serves as the

power supply to the upper gate driver CMOS circuitry. Since the quiescent current in this CMOS circuitry is very low (typically 45μA in the on-state), the majority of the drop in the V_{BS} voltage when Q1 is on occurs due to the transfer of charge from the bootstrap capacitor to the gate of the power MOSFET.

VB should be bypassed to VS as close as possible to the leads of the IC with a low ESR/ESL capacitor. A PCB layout example is shown in figure 20. A rule of thumb for the value of this capacitor is to keep its minimum value at least 50 times the value of the total input capacitance (C_{iss}) of the MOSFET or IGBT being driven. In addition, the VS lead should be connected directly to the high side power MOSFET source.

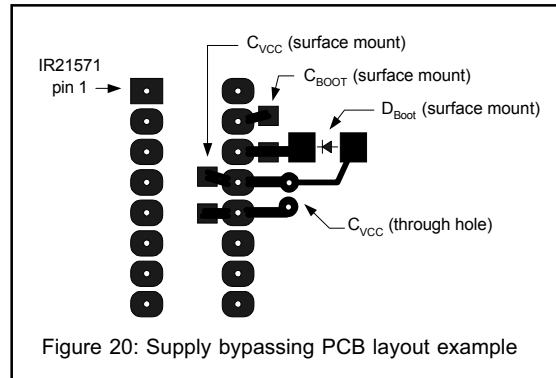

Case outlines

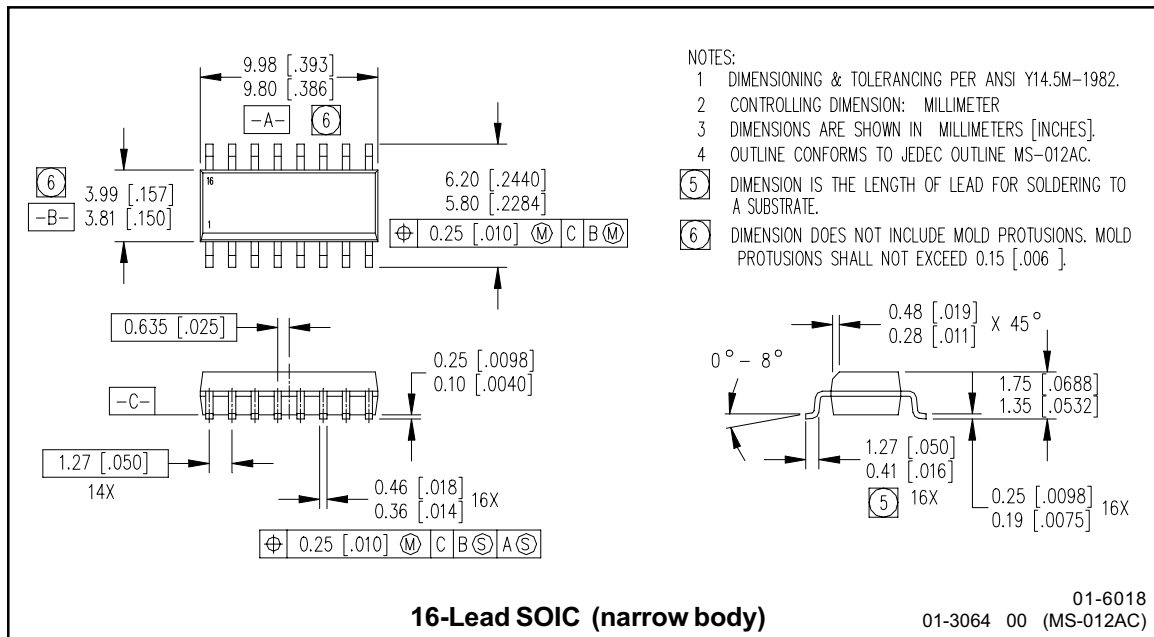
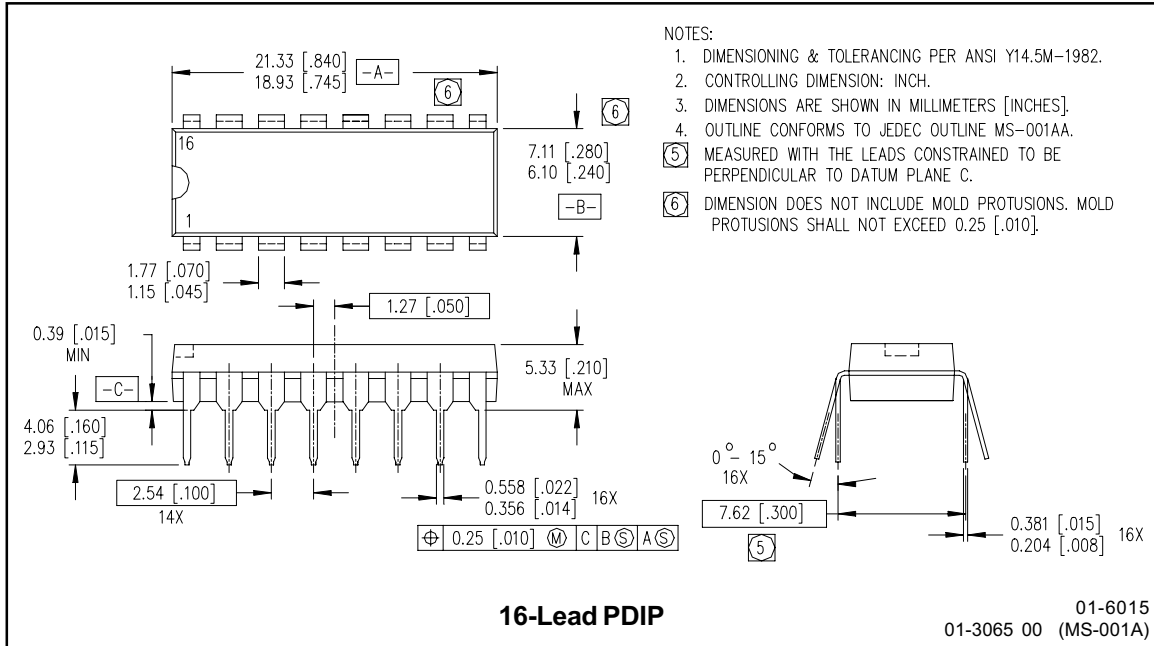

IR21571(S) & (PbF)

LEADFREE PART MARKING INFORMATION

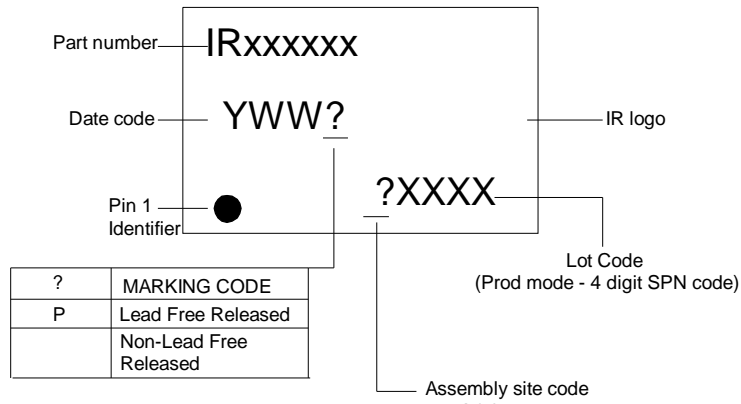

ORDER INFORMATION

Basic Part (Non-Lead Free)

16-Lead PDIP IR21571 order IR21571
16-Lead SOIC IR21571S order IR21571S

Leadfree Part

16-Lead PDIP IR21571 order IR21571PbF
16-Lead SOIC IR21571S order IR21571SPbF

Rev.	Date	Page #	Description of Change
M	6/10/80	1	"Not Recommended for new design: Please use IRS21571D"

Looking for pricing, stock, or lifecycle information?

Click below to explore more details on WIN SOURCE:

 [View IR21571SPBF on WIN SOURCE](#)

 [Infineon Technologies](#) Information

Optimize Your Supply Chain with WIN SOURCE Solutions

-  Global Sourcing Solution
-  Obsolete Management
-  Cost Control Management
-  Shortage Management
-  Alternative Solution
-  Excess Inventory Management