

IMPORTANT NOTICE:

This part is no longer recommended for new designs; please use **IR2175, IR2177, IR21771, IR2277 or IR22771.**

Features

- Floating channel up to +600V
- Monolithic integration
- Overcurrent sensing through shunt resistor
- Low IQBS allows the boot strap power supply
- Independent fast 1μsec overcurrent trip signal
- High common mode noise immunity
- Input overvoltage protection for IGBT short circuit condition
- Open Drain outputs
- Available in Lead-Free

Description

IR2170(S) is the monolithic over current sensing IC designed for motor drive applications. It senses the motor phase current through an external shunt resistor, detects overcurrent condition, and transfers the signal to the low side. IR's proprietary high voltage isolation technology is implemented to enable the high bandwidth signal processing. The dedicated overcurrent trip (OC) signal facilitates IGBT short circuit protection. The OC output pulse width can be programmed by the external resistor and capacitor. The open-drain outputs make easy for any interface from 3.3V to 15V.

OVER CURRENT SENSING IC

Product Summary

V _{OFFSET}	600V _{max}
I _{QBS}	1mA
Overcurrent trip signal delay	1.5μsec (typ)
Overcurrent trip level	+/-260mV (typ.)

Packages

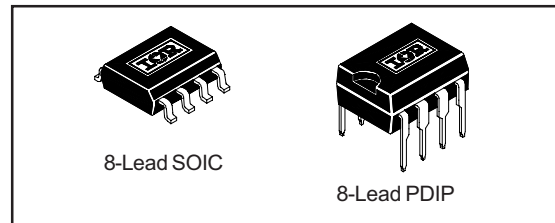

Typical Application

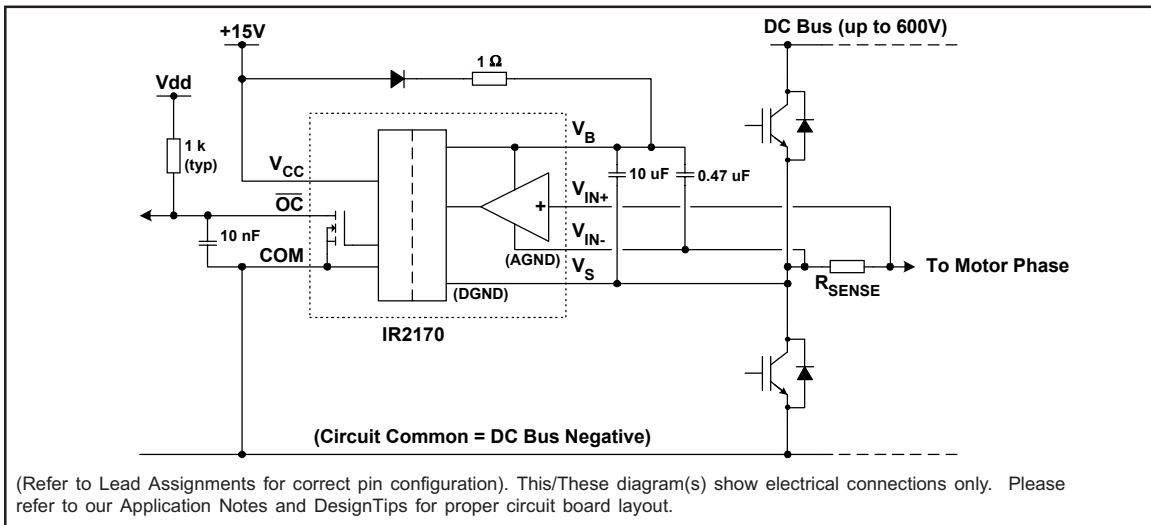

Absolute Maximum Ratings

Absolute maximum ratings indicate sustained limits beyond which damage to the device may occur. All voltage parameters are absolute voltages referenced to COM, all currents are defined positive into any lead. The thermal resistance and power dissipation ratings are measured under board mounted and still air conditions.

Symbol	Definition	Min.	Max.	Units	
V _S	High side offset voltage	-0.3	600	V	
V _{BS}	High side floating supply voltage	-0.3	25		
V _{CC}	Low side and logic fixed supply voltage	-0.3	25		
V _{IN}	Maximum input voltage between V _{IN+} and V _{IN-}	-5	5		
V _{OC}	Overcurrent output voltage	COM-0.3	V _{CC} +0.3		
V _{IN-}	V _{IN-} input voltage (note 1)	V _S -5	V _{B+} +0.3		
dV/dt	Allowable offset voltage slew rate	—	50	V/ns	
P _D	Package power dissipation @ T _A ≤ +25°C	8 lead SOIC	—	.625	W
		8 lead PDIP	—	1.0	
R _{thJA}	Thermal resistance, junction to ambient	8 lead SOIC	—	200	°C/W
		8 lead PDIP	—	125	
T _J	Junction temperature	—	150	°C	
T _S	Storage temperature	-55	150		
T _L	Lead temperature (soldering, 10 seconds)	—	300		

Note 1: Capacitors are required between V_B and V_{IN-}, and between V_B and V_S pins when bootstrap power is used. The external power supply, when used, is required between V_S and V_{IN-}, and between V_B and V_S pins.

Recommended Operating Conditions

The output logic timing diagram is shown in figure 1. For proper operation the device should be used within the recommended conditions.

Symbol	Definition	Min.	Max.	Units
V _B	High side floating supply voltage	V _S +13.0	V _S +20	V
V _S	High side floating supply offset voltage	note 2	600	
V _{OC}	Overcurrent output voltage	COM	V _{CC}	
V _{CC}	Low side and logic fixed supply voltage	9.5	20	
V _{IN}	Input voltage between V _{IN+} and V _{IN-}	-260	+260	mV
T _A	Ambient temperature	-40	125	°C

Note 2: Logic operation for V_S of -5 to +600V. Logic state held for V_S of -5V to -V_{BS}. (Please refer to the Design Tip DT97-3 for more details).

DC Electrical Characteristics

$V_{CC} = V_{BS} = 15V$, and $T_A = 25^\circ C$ unless otherwise specified.

Symbol	Definition	Min.	Typ.	Max.	Units	Test Conditions
V_{OC+}	Overcurrent trip positive input voltage	—	260	—	mV	
V_{OC-}	Overcurrent trip negative input voltage	—	-260	—		
I_{LK}	Offset supply leakage current	—	—	50	μA	$V_B = V_S = 600V$
I_{QBS}	Quiescent V_{BS} supply current	—	1	2	mA	$V_S = 0V$
I_{QCC}	Quiescent V_{CC} supply current	—	—	0.5		$V_O = 1V$
I_{OCC}	OC output sink current	10	—	—		$V_O = 1V$
		1	—	—		$V_O = 0.1V$

AC Electrical Characteristics

$V_{CC} = V_{BS} = 15V$, and $T_A = 25^\circ C$ unless otherwise specified.

Symbol	Definition	Min.	Typ.	Max.	Units	Test Conditions
Proagation delay characteristics						
t_{doc}	Propagation delay time of OC	1	1.5	—	μsec	
t_{woc}	Low true pulse width of OC	—	1	—		

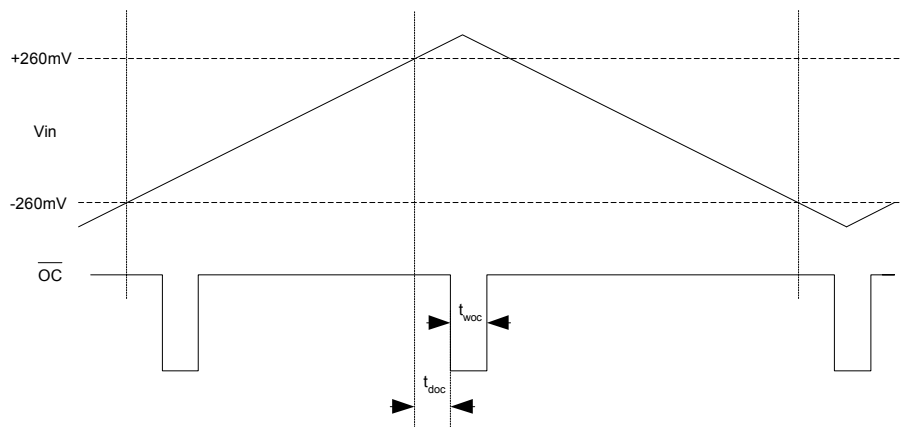

Figure 1. OC Waveform

IR2170(S)&(PbF)

Lead Definitions

Symbol	Description
V _{CC}	Low side and logic supply voltage
COM	Low side logic ground
V _{IN+}	Positive sense input
V _{IN-}	Negative sense input
V _B	High side supply
V _S	High side return
\overline{OC}	Overcurrent output (negative logic)
N.C.	No connection

Lead Assignments

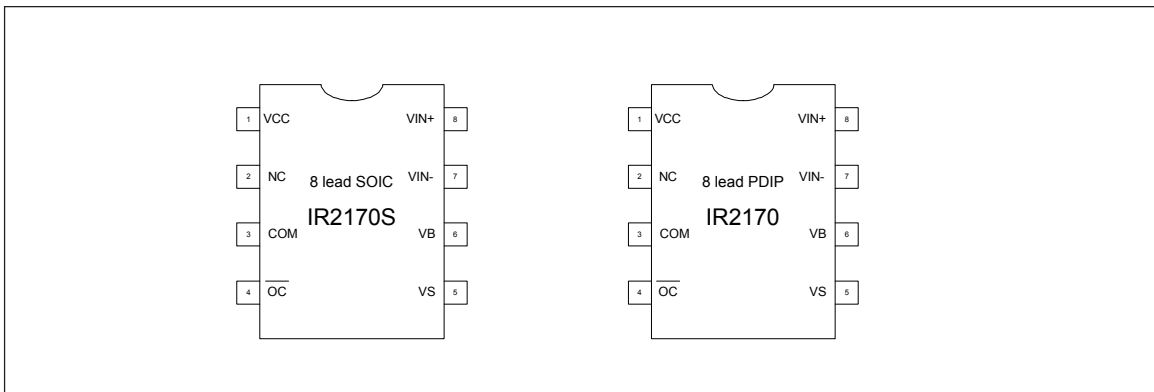

Case outlines

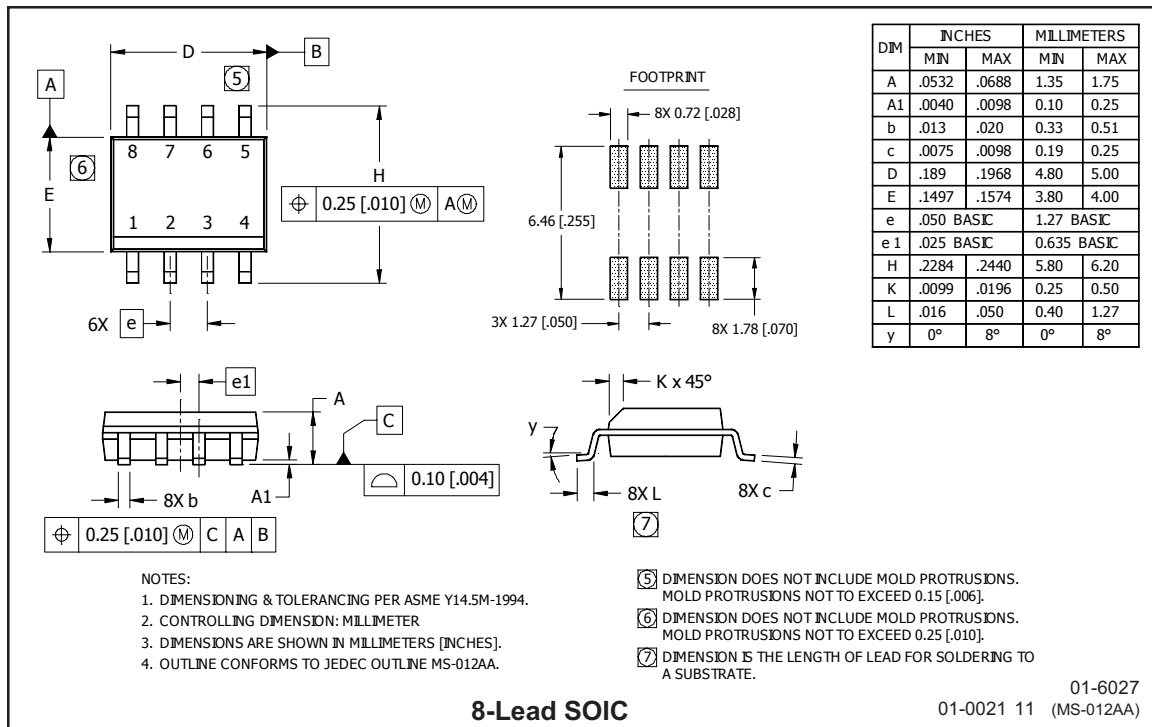
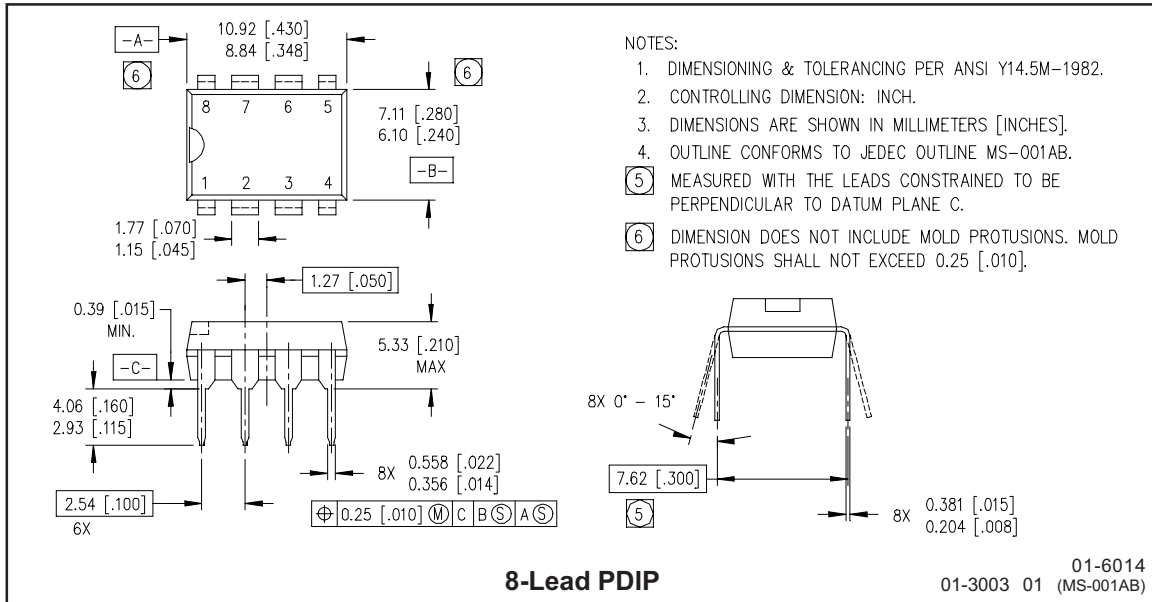

IR2170(S)&(PbF)

International
IR Rectifier

LEADFREE PART MARKING INFORMATION

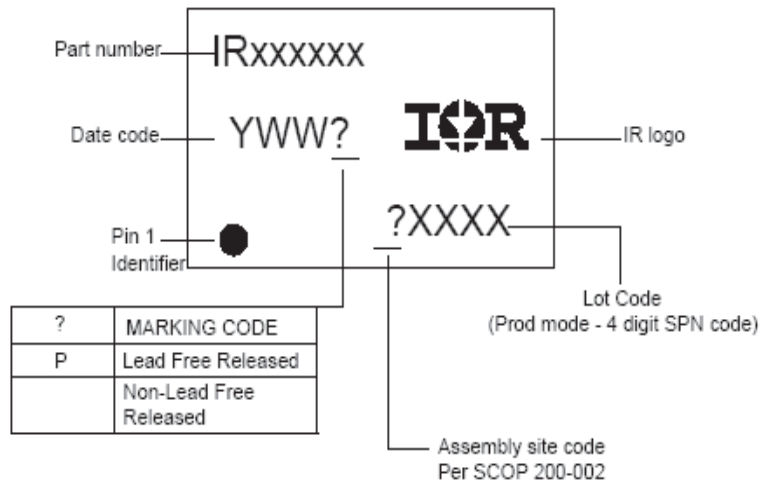

ORDER INFORMATION

Basic Part (Non-Lead Free)

8-Lead PDIP IR2170 order IR2170
8-Lead SOIC IR2170S order IR2170S

Lead-Free Part

8-Lead PDIP IR2170 order IR2170PbF
8-Lead SOIC IR2170S order IR2170SPbF

International
IR Rectifier



This product has been designed and qualified for the Industrial market.
Qualification Standards can be found on IR's Web Site.
Data and specifications subject to change without notice.

IR WORLD HEADQUARTERS: 233 Kansas St., El Segundo, California 90245, USA Tel: (310) 252-7105
TAC Fax: (310) 252-7903

Visit us at www.irf.com for sales contact information.
3/1/2006

Looking for pricing, stock, or lifecycle information?

Click below to explore more details on WIN SOURCE:

-  [View IR2170S on WIN SOURCE](#)
-  [Infineon Technologies](#) Information

Optimize Your Supply Chain with WIN SOURCE Solutions

-  Global Sourcing Solution
-  Obsolete Management
-  Cost Control Management
-  Shortage Management
-  Alternative Solution
-  Excess Inventory Management