



**THE DATASHEET OF
FJE5304DTU**





Is Now Part of



ON Semiconductor®

To learn more about ON Semiconductor, please visit our website at www.onsemi.com

Please note: As part of the Fairchild Semiconductor integration, some of the Fairchild orderable part numbers will need to change in order to meet ON Semiconductor's system requirements. Since the ON Semiconductor product management systems do not have the ability to manage part nomenclature that utilizes an underscore (_), the underscore (_) in the Fairchild part numbers will be changed to a dash (-). This document may contain device numbers with an underscore (_). Please check the ON Semiconductor website to verify the updated device numbers. The most current and up-to-date ordering information can be found at www.onsemi.com. Please email any questions regarding the system integration to Fairchild_questions@onsemi.com.

ON Semiconductor and the ON Semiconductor logo are trademarks of Semiconductor Components Industries, LLC dba ON Semiconductor or its subsidiaries in the United States and/or other countries. ON Semiconductor owns the rights to a number of patents, trademarks, copyrights, trade secrets, and other intellectual property. A listing of ON Semiconductor's product/patent coverage may be accessed at www.onsemi.com/site/pdf/Patent-Marking.pdf. ON Semiconductor reserves the right to make changes without further notice to any products herein. ON Semiconductor makes no warranty, representation or guarantee regarding the suitability of its products for any particular purpose, nor does ON Semiconductor assume any liability arising out of the application or use of any product or circuit, and specifically disclaims any and all liability, including without limitation special, consequential or incidental damages. Buyer is responsible for its products and applications using ON Semiconductor products, including compliance with all laws, regulations and safety requirements or standards, regardless of any support or applications information provided by ON Semiconductor. "Typical" parameters which may be provided in ON Semiconductor data sheets and/or specifications can and do vary in different applications and actual performance may vary over time. All operating parameters, including "Typicals" must be validated for each customer application by customer's technical experts. ON Semiconductor does not convey any license under its patent rights nor the rights of others. ON Semiconductor products are not designed, intended, or authorized for use as a critical component in life support systems or any FDA Class 3 medical devices or medical devices with a same or similar classification in a foreign jurisdiction or any devices intended for implantation in the human body. Should Buyer purchase or use ON Semiconductor products for any such unintended or unauthorized application, Buyer shall indemnify and hold ON Semiconductor and its officers, employees, subsidiaries, affiliates, and distributors harmless against all claims, costs, damages, and expenses, and reasonable attorney fees arising out of, directly or indirectly, any claim of personal injury or death associated with such unintended or unauthorized use, even if such claim alleges that ON Semiconductor was negligent regarding the design or manufacture of the part. ON Semiconductor is an Equal Opportunity/Affirmative Action Employer. This literature is subject to all applicable copyright laws and is not for resale in any manner.



FJE5304D NPN Triple Diffused Planar Silicon Transistor

Features

- High-Voltage, High-Speed Power Switch Applications
- Wide Safe Operating Area
- Built-in Free-Wheeling diode
- Suitable for Electronic Ballast Applications
- Small Variance in Storage Time

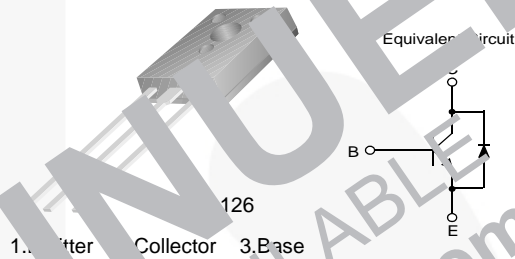

Ordering Information

Part Number	Top Mark	Package	Packing Method
FJE5304D	5304D	TO-126 3L	Bulk
FJE5304DU	J5304D	TO-126 3L	Rail

Absolute Maximum Ratings

Stresses exceeding the absolute maximum ratings may damage the device. The device may not function or be operable above the recommended operating conditions and stressing the parts to these levels is not recommended. In addition, extended exposure to stresses above the recommended operating conditions may affect device reliability. The absolute maximum ratings are stress ratings only. Values are at $T_C = 25^\circ\text{C}$ unless otherwise noted.

Symbol	Parameter	Value	Unit
V_{CBO}	Collector-Base Voltage	700	V
V_{CEO}	Collector-Emitter Voltage	400	V
V_{EBO}	Emitter-Base Voltage	12	V
I_C	Collector Current (DC)	4	A
I_{CP}	Collector Current (Pulse) ⁽¹⁾	8	A
I_B	Base Current (DC)	2	A
I_{BP}	Base Current (Pulse) ⁽¹⁾	4	A
T_{STG}	Storage Temperature Range	-65 to 150	$^\circ\text{C}$

Note:

1. Pulse test: pulse width $\leq 300 \mu\text{s}$, duty cycle $\leq 2\%$.

Thermal Characteristics

Values are at $T_C = 25^\circ\text{C}$ unless otherwise noted.

Symbol	Parameter	Max.	Unit
P_C	Collector Dissipation ($T_C = 25^\circ\text{C}$)	30	W
$R_{\theta JC}$	Thermal Resistance, Junction to Case	4.17	$^\circ\text{C/W}$
$R_{\theta JA}$	Thermal Resistance, Junction to Ambient	83.3	$^\circ\text{C/W}$

Electrical Characteristics⁽²⁾

Values are at $T_C = 25^\circ\text{C}$ unless otherwise noted.

Symbol	Parameter	Conditions	Min.	Typ.	Max.	Unit
BV_{CBO}	Collector-Base Breakdown Voltage	$I_C = 1\text{ mA}, I_E = 0$	700			V
BV_{CEO}	Collector-Emitter Breakdown Voltage	$I_C = 5\text{ mA}, I_B = 0$	700			V
BV_{EBO}	Emitter-Base Breakdown Voltage	$I_E = 1\text{ mA}, I_C = 0$				V
I_{CES}	Collector Cut-Off Current	$V_{CE} = 70\text{ V}, I_B = 0$			100	μA
I_{CEO}	Collector Cut-Off Current	$V_{CE} = 40\text{ V}, I_B = 0$			250	μA
I_{EBO}	Emitter Cut-Off Current	$V_{EB} = 12\text{ V}, I_C = 0$			100	μA
h_{FE}	DC Current Gain	$V_{CE} = 5\text{ V}, I_C = 10\text{ mA}$	10			
		$V_{CE} = 5\text{ V}, I_C = 2\text{ A}$	8		40	
$V_{CE(sat)}$	Collector-Emitter Saturation Voltage	$I_C = 0.5\text{ A}, I_B = 0.1\text{ A}$			0.7	V
		$I_C = 1\text{ A}, I_B = 0.2\text{ A}$			1.0	
		$I_C = 2.5\text{ A}, I_B = 0.5\text{ A}$			1.5	
$V_{BE(sat)}$	Collector-Base Saturation Voltage	$I_C = 0.5\text{ A}, I_B = 0.1\text{ A}$			1.1	V
		$I_C = 1\text{ A}, I_B = 0.2\text{ A}$			1.2	
		$I_C = 2.5\text{ A}, I_B = 0.5\text{ A}$			1.3	
V_f	Internal Base Forward Voltage Drop	$I_E = 2\text{ A}$			2.5	V
Inductive Load Switching ($V_{CC} = 200\text{ V}$)						
t_s	Storage Time	$I_C = 2\text{ A}, I_{B1} = 0.4\text{ A}$		0.6		μs
t_f	Fall Time	$V_{CE(off)} = -5\text{ V}, L = 200\text{ }\mu\text{H}$		0.1		μs
Resistive Load Switching ($V_{CC} = 250\text{ V}$)						
t_{stg}	Storage Time	$I_C = 2\text{ A}, I_{B1} = I_{B2} = 0.4\text{ A}$			2.9	μs
t_f	Fall Time	$T_P = 30\text{ }\mu\text{s}$		0.2		μs

Note:

2. Pulse test: pulse width $\leq 300\text{ }\mu\text{s}$, duty cycle $\leq 2\%$.

Typical Performance Characteristics

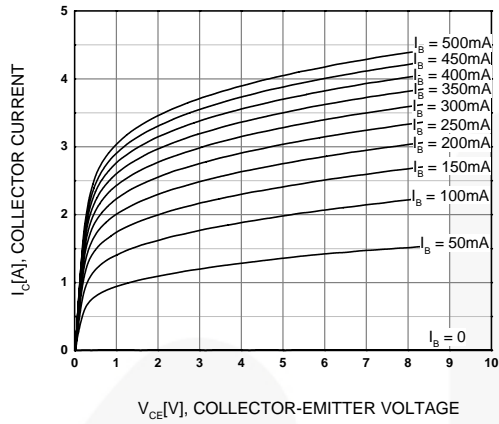

Figure 1. Static Characteristic

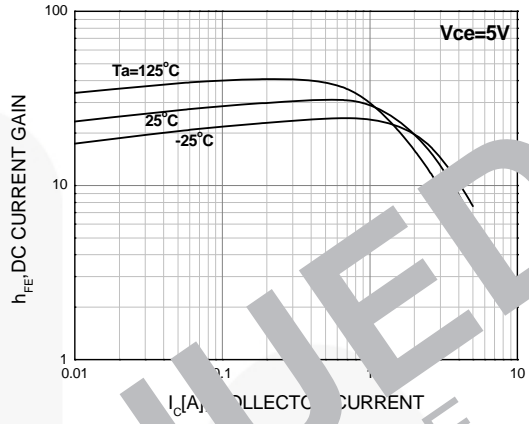

Figure 2. DC Current Gain

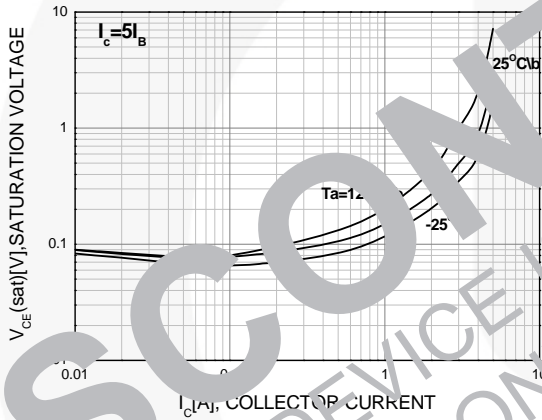

Figure 3. Collector-Emitter Saturation Voltage

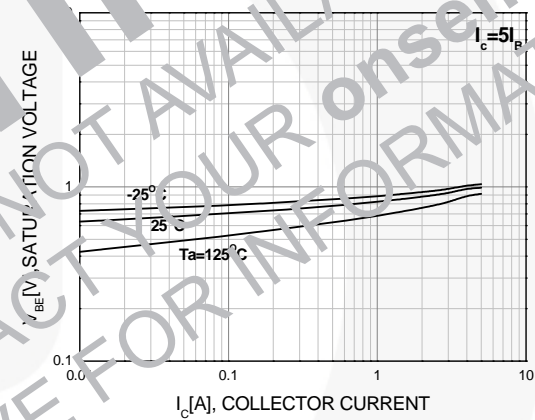

Figure 4. Base-Emitter Saturation Voltage

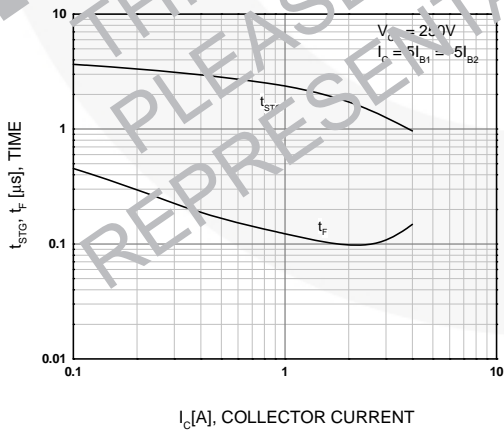

Figure 5. Resistive Load Switching Time

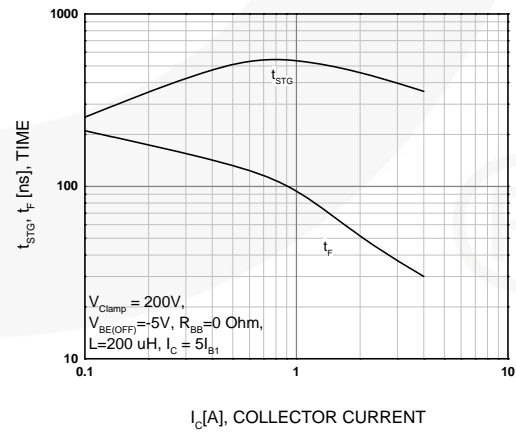

Figure 6. Inductive Load Switching Time

Typical Performance Characteristics (Continued)

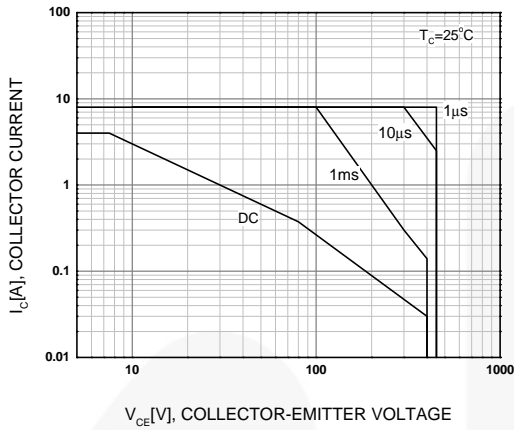

Figure 7. Forward Bias Safe Operating Area

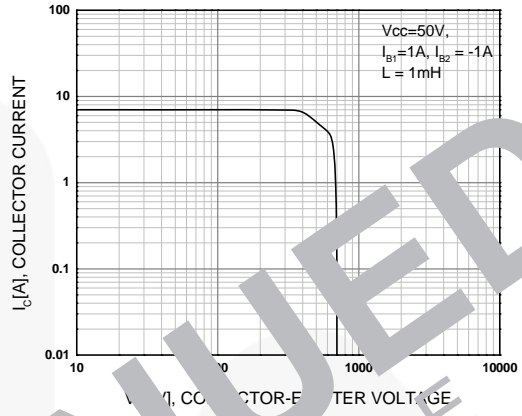

Figure 8. Reverse Bias Safe Operating Area

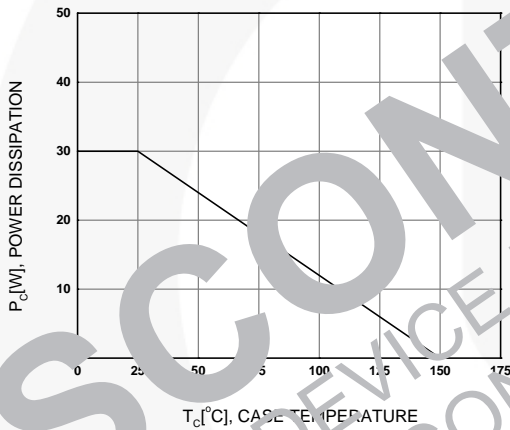
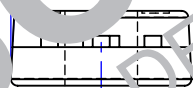
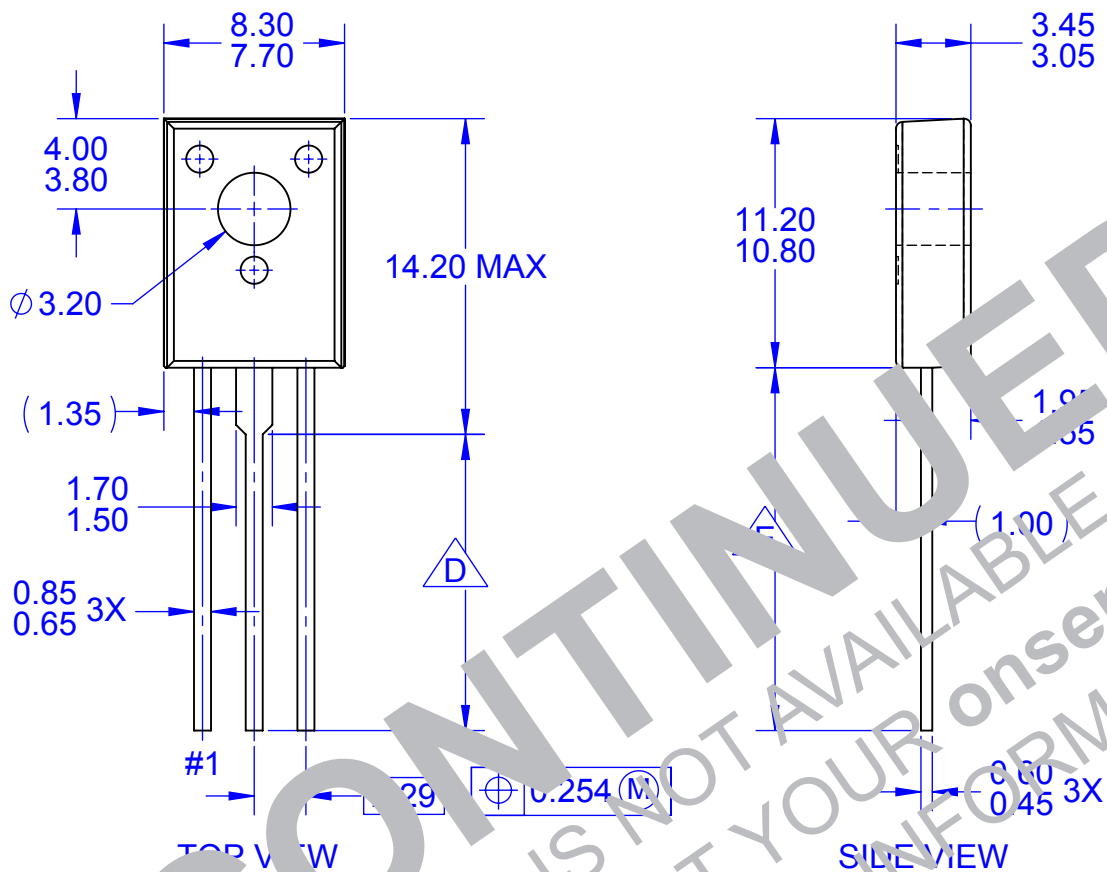

Figure 9. Power Derating



FRONT VIEW

PRODUCTION CODE	TERMINAL LENGTH "D"	TERMINAL LENGTH "E"
TSSTU	3.45 - 4.05	6.45-7.45
TSTU	2.36 - 2.96	5.36-6.36
NONE (STD LENGTH)	12.76 - 13.36	15.76-16.76

NOTES:

- A. NO INDUSTRY STANDARD APPLIES TO THIS PACKAGE
- B. ALL DIMENSIONS ARE IN MILLIMETERS
- C. DIMENSIONS ARE EXCLUSIVE OF BURRS, MOLD FLASH, AND TIE BAR PROTRUSIONS

 FOR TERMINAL LENGTH "D", REFER TO TABLE

 FOR TERMINAL LENGTH "E", REFER TO TABLE

F. DRAWING FILENAME: MKT-TO126Arev2



DISCONTINUED
THIS DEVICE IS NOT AVAILABLE
PLEASE CONTACT YOUR onsemi
SALES REPRESENTATIVE FOR INFORMATION

ON Semiconductor and  are trademarks of Semiconductor Components Industries, LLC dba ON Semiconductor or its subsidiaries in the United States and/or other countries. ON Semiconductor owns the rights to a number of patents, trademarks, copyrights, trade secrets, and other intellectual property. A listing of ON Semiconductor's product/patent coverage may be accessed at www.onsemi.com/site/pdf/Patent-Marking.pdf. ON Semiconductor reserves the right to make changes without further notice to any products herein. ON Semiconductor makes no warranty, representation or guarantee regarding the suitability of its products for any particular purpose, nor does ON Semiconductor assume any liability arising out of the application or use of any product or circuit, and specifically disclaims any and all liability, including without limitation special, consequential or incidental damages. Buyer is responsible for its products and applications using ON Semiconductor products, including compliance with all laws, regulations and safety requirements or standards, regardless of any support or applications information provided by ON Semiconductor. "Typical" parameters which may be provided in ON Semiconductor data sheets and/or specifications can and do vary in different applications and actual performance may vary over time. All operating parameters, including "Typicals" must be validated for each customer application by customer's technical experts. ON Semiconductor does not convey any license under its patent rights nor the rights of others. ON Semiconductor products are not designed, intended, or authorized for use as a critical component in life support systems or any FDA Class 3 medical devices or medical devices with a same or similar classification in a foreign jurisdiction or any devices intended for implantation in the human body. Should Buyer purchase or use ON Semiconductor products for any such unintended or unauthorized application, Buyer shall indemnify and hold ON Semiconductor and its officers, employees, subsidiaries, affiliates, and distributors harmless against all claims, costs, damages, and expenses, and reasonable attorney fees arising out of, directly or indirectly, any claim of personal injury or death associated with such unintended or unauthorized use, even if such claim alleges that ON Semiconductor was negligent regarding the design or manufacture of the part. ON Semiconductor is an Equal Opportunity/Affirmative Action Employer. This literature is subject to all applicable copyright laws and is not for resale in any manner.

PUBLICATION ORDERING INFORMATION

LITERATURE FULFILLMENT:

Literature Distribution Center for ON Semiconductor
19521 E. 32nd Pkwy, Aurora, Colorado 80011 USA
Phone: 303-675-2175 or 800-344-3860 Toll Free USA/Canada
Fax: 303-675-2176 or 800-344-3867 Toll Free USA/Canada
Email: orderlit@onsemi.com

N. American Technical Support: 800-282-9855 Toll Free
USA/Canada
Europe, Middle East and Africa Technical Support:
Phone: 421 33 790 2910
Japan Customer Focus Center
Phone: 81-3-5817-1050

ON Semiconductor Website: www.onsemi.com
Order Literature: <http://www.onsemi.com/orderlit>
For additional information, please contact your local
Sales Representative

Looking for pricing, stock, or lifecycle information?

Click below to explore more details on WIN SOURCE:

 [View FJE5304DTU on WIN SOURCE](#)

 [ON Semiconductor](#) Information

Optimize Your Supply Chain with WIN SOURCE Solutions

-  Global Sourcing Solution
-  Obsolete Management
-  Cost Control Management
-  Shortage Management
-  Alternative Solution
-  Excess Inventory Management