



**THE DATASHEET OF  
IRF7506TRPBF**



# IRF7506PbF

- Lead-Free
- Generation V Technology
- Ultra Low On-Resistance
- Dual P-Channel MOSFET
- Very Small SOIC Package
- Low Profile (<1.1mm)
- Available in Tape & Reel
- Fast Switching

## Description

Fifth Generation HEXFETs from International Rectifier utilize advanced processing techniques to achieve extremely low on-resistance per silicon area. This benefit, combined with the fast switching speed and ruggedized device design that HEXFET Power MOSFETs are well known for, provides the designer with an extremely efficient and reliable device for use in a wide variety of applications.

The new Micro8 package, with half the footprint area of the standard SO-8, provides the smallest footprint available in an SOIC outline. This makes the Micro8 an ideal device for applications where printed circuit board space is at a premium. The low profile (<1.1mm) of the Micro8 will allow it to fit easily into extremely thin application environments such as portable electronics and PCMCIA cards.

## Absolute Maximum Ratings

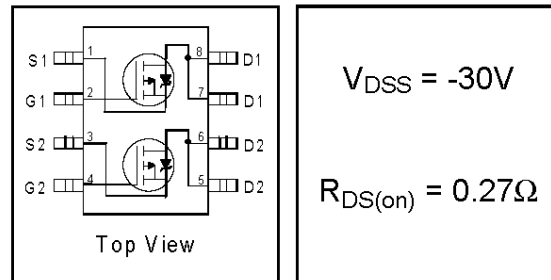
|                                | Parameter  | Max.         | Units |
|--------------------------------|--|--------------|-------|
| $I_D @ T_A = 25^\circ\text{C}$ | Continuous Drain Current, $V_{GS} @ -10\text{V}$ | -1.7         | A     |
| $I_D @ T_A = 70^\circ\text{C}$ | Continuous Drain Current, $V_{GS} @ -10\text{V}$ | -1.4         |       |
| $I_{DM}$                       | Pulsed Drain Current ①                           | -9.6         |       |
| $P_D @ T_A = 25^\circ\text{C}$ | Power Dissipation                                | 1.25         | W     |
|                                | Linear Derating Factor                           | 10           | mW/°C |
| $V_{GS}$                       | Gate-to-Source Voltage                           | $\pm 20$     | V     |
| dv/dt                          | Peak Diode Recovery dv/dt ②                      | 5.0          | V/ns  |
| $T_J, T_{STG}$                 | Junction and Storage Temperature Range           | -55 to + 150 | °C    |

## Thermal Resistance Ratings

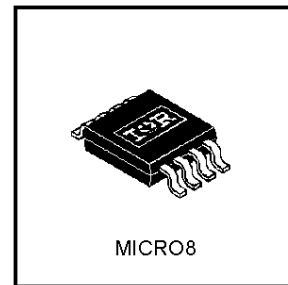
|                 | Parameter                     | Typ. | Max. | Units |
|-----------------|-------------------------------|------|------|-------|
| $R_{\theta JA}$ | Maximum Junction-to-Ambient ④ | —    | 100  | °C/W  |

All Micro8 Data Sheets reflect improved Thermal Resistance, Power and Current -Handling Ratings- effective only for product marked with Date Code 505 or later .

## HEXFET® Power MOSFET



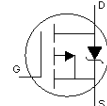
|                           |
|---------------------------|
| $V_{DSS} = -30\text{V}$   |
| $R_{DS(on)} = 0.27\Omega$ |



## Electrical Characteristics @ $T_J = 25^\circ\text{C}$ (unless otherwise specified)

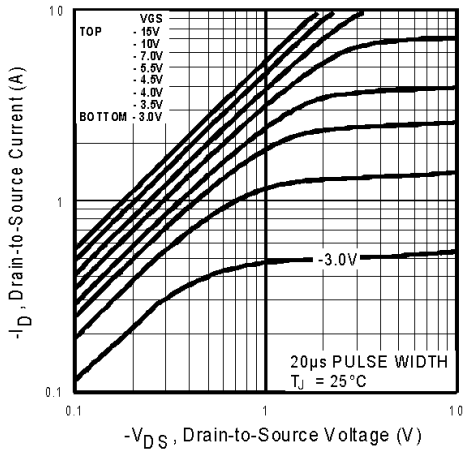
|                                 | Parameter                            | Min. | Typ.   | Max. | Units    | Conditions  |
|---------------------------------|--------------------------------------|------|--------|------|----------|---|
| $V_{(BR)DSS}$                   | Drain-to-Source Breakdown Voltage    | -30  | —      | —    | V        | $V_{GS} = 0V, I_D = -250\mu A$                        |
| $\Delta V_{(BR)DSS}/\Delta T_J$ | Breakdown Voltage Temp. Coefficient  | —    | -0.039 | —    | V/°C     | Reference to $25^\circ\text{C}, I_D = -1mA$           |
| $R_{DS(on)}$                    | Static Drain-to-Source On-Resistance | —    | —      | 0.27 | $\Omega$ | $V_{GS} = -10V, I_D = -1.2A$ ③                        |
|                                 |                                      | —    | —      | 0.45 |          | $V_{GS} = -4.5V, I_D = -0.60A$ ③                      |
| $V_{GS(th)}$                    | Gate Threshold Voltage               | -1.0 | —      | —    | V        | $V_{DS} = V_{GS}, I_D = -250\mu A$                    |
| $g_{fs}$                        | Forward Transconductance             | 0.92 | —      | —    | S        | $V_{DS} = -10V, I_D = -0.60A$                         |
| $I_{DSS}$                       | Drain-to-Source Leakage Current      | —    | —      | -1.0 | $\mu A$  | $V_{DS} = -24V, V_{GS} = 0V$                          |
|                                 |                                      | —    | —      | -25  |          | $V_{DS} = -24V, V_{GS} = 0V, T_J = 125^\circ\text{C}$ |
| $I_{GSS}$                       | Gate-to-Source Forward Leakage       | —    | —      | -100 | nA       | $V_{GS} = -20V$                                       |
|                                 | Gate-to-Source Reverse Leakage       | —    | —      | 100  |          | $V_{GS} = 20V$  |
| $Q_g$                           | Total Gate Charge                    | —    | 7.5    | 11   | nC       | $I_D = -1.2A$   |
| $Q_{gs}$                        | Gate-to-Source Charge                | —    | 1.3    | 1.9  |          | $V_{DS} = -24V$                                       |
| $Q_{gd}$                        | Gate-to-Drain ("Miller") Charge      | —    | 2.5    | 3.7  |          | $V_{GS} = -10V$ , See Fig. 6 and 9 ③                  |
| $t_{d(on)}$                     | Turn-On Delay Time                   | —    | 9.7    | —    | ns       | $V_{DD} = -15V$                                       |
| $t_r$                           | Rise Time                            | —    | 12     | —    |          | $I_D = -1.2A$   |
| $t_{d(off)}$                    | Turn-Off Delay Time                  | —    | 19     | —    |          | $R_G = 6.2\Omega$                                     |
| $t_f$                           | Fall Time                            | —    | 9.3    | —    |          | $R_D = 12\Omega$ , See Fig. 10 ③                      |
| $C_{iss}$                       | Input Capacitance                    | —    | 180    | —    | pF       | $V_{GS} = 0V$   |
| $C_{oss}$                       | Output Capacitance                   | —    | 87     | —    |          | $V_{DS} = -25V$                                       |
| $C_{rss}$                       | Reverse Transfer Capacitance         | —    | 42     | —    |          | $f = 1.0MHz$ , See Fig. 5                             |

## Source-Drain Ratings and Characteristics

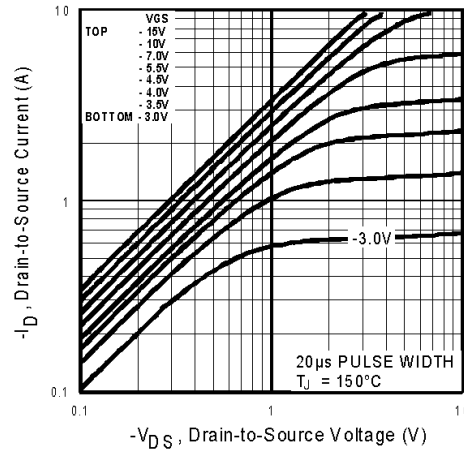
|          | Parameter                              | Min. | Typ. | Max.  | Units | Conditions   |
|----------|--|------|------|-------|-------|--|
| $I_S$    | Continuous Source Current (Body Diode) | —    | —    | -1.25 | A     | MOSFET symbol showing the integral reverse p-n junction diode.  |
| $I_{SM}$ | Pulsed Source Current (Body Diode) ①   | —    | —    | -9.6  |       |  |
| $V_{SD}$ | Diode Forward Voltage                  | —    | —    | -1.2  | V     | $T_J = 25^\circ\text{C}, I_S = -1.2A, V_{GS} = 0V$ ③   |
| $t_{rr}$ | Reverse Recovery Time                  | —    | 30   | 45    | ns    | $T_J = 25^\circ\text{C}, I_F = -1.2A$  |
| $Q_{rr}$ | Reverse Recovery Charge                | —    | 37   | 55    | nC    | $di/dt = -100A/\mu s$ ③  |

### Notes:

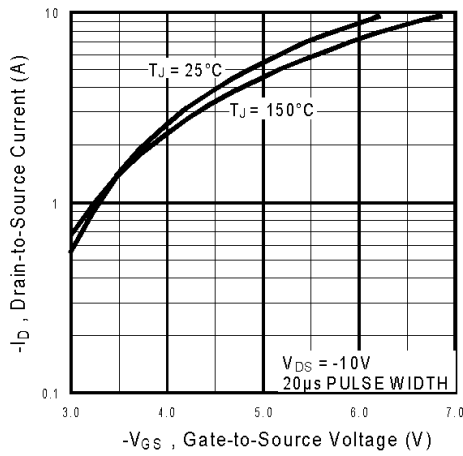
- ① Repetitive rating – pulse width limited by max. junction temperature (see fig. 11)
- ②  $I_{SD} \leq -1.2A, di/dt \leq -140A/\mu s, V_{DD} \leq V_{(BR)DSS}, T_J \leq 150^\circ\text{C}$
- ③ Pulse width  $\leq 300\mu s$  – duty cycle  $\leq 2\%$
- ④ Surface mounted on FR-4 board,  $t \leq 10sec.$



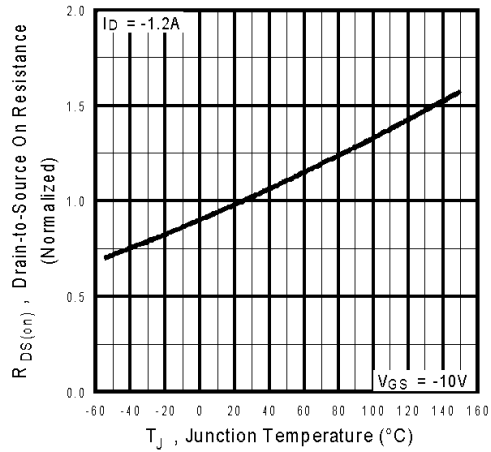
**Fig 1.** Typical Output Characteristics



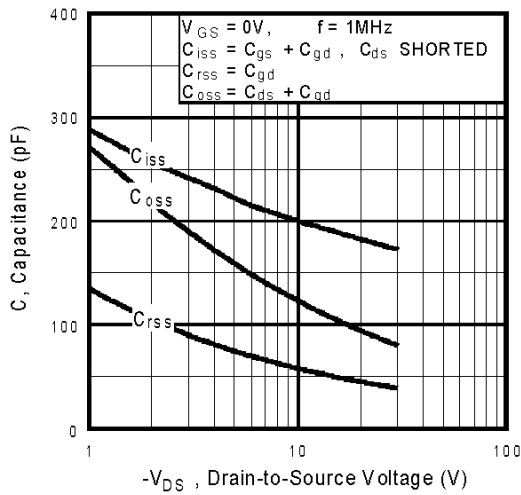
**Fig 2.** Typical Output Characteristics



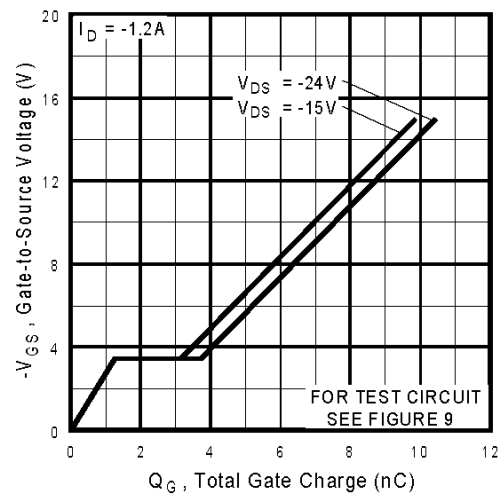
**Fig 3.** Typical Transfer Characteristics



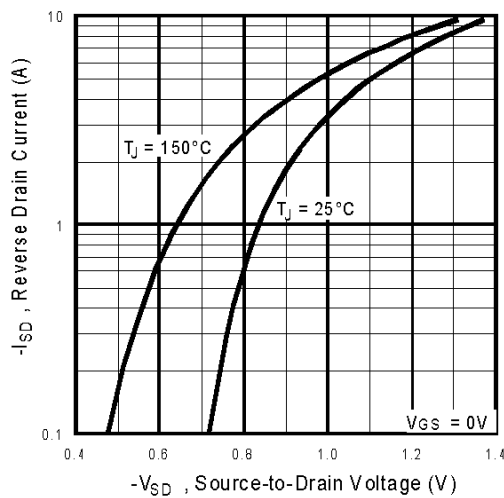
**Fig 4.** Normalized On-Resistance Vs. Temperature



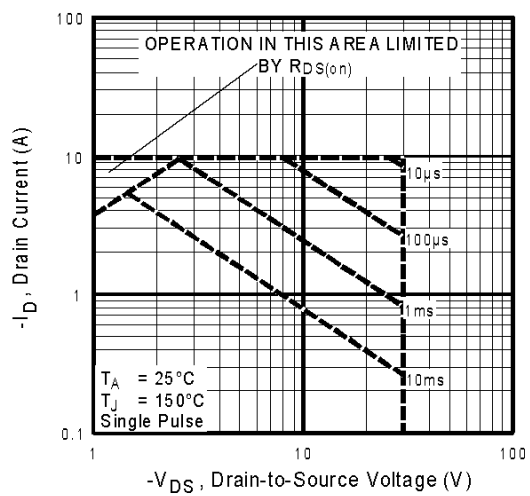
**Fig 5.** Typical Capacitance Vs. Drain-to-Source Voltage



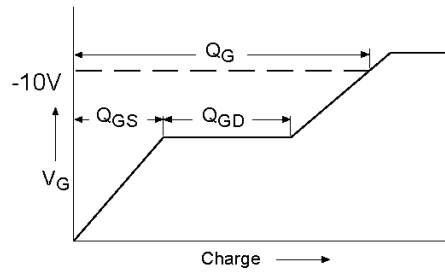
**Fig 6.** Typical Gate Charge Vs. Gate-to-Source Voltage



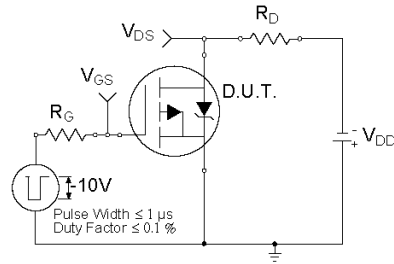
**Fig 7.** Typical Source-Drain Diode Forward Voltage



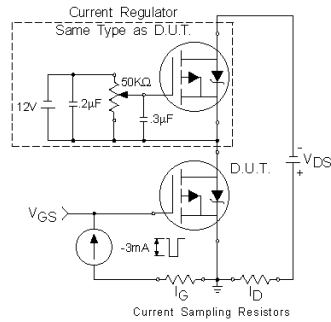
**Fig 8.** Maximum Safe Operating Area



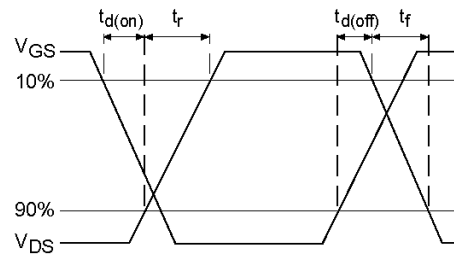
**Fig 9a.** Basic Gate Charge Waveform



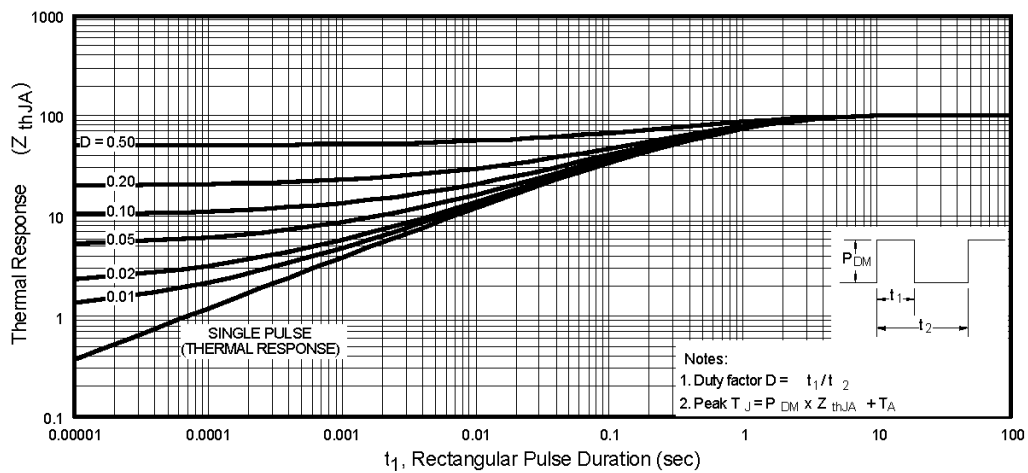
**Fig 10a.** Switching Time Test Circuit



**Fig 9b.** Gate Charge Test Circuit

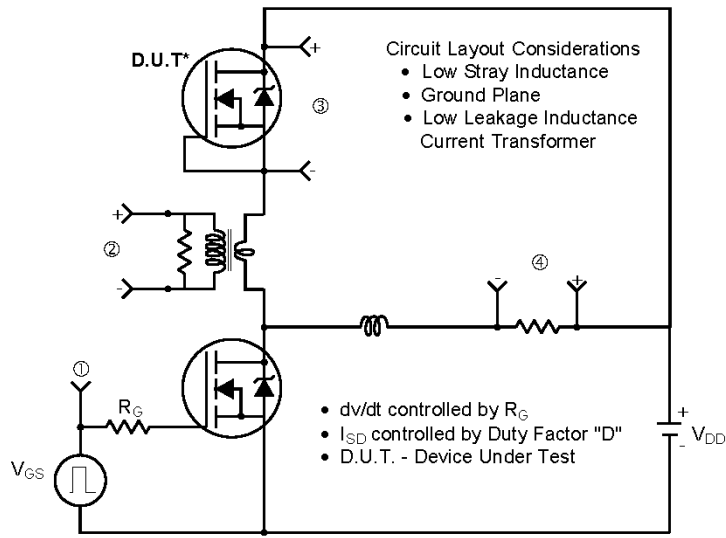


**Fig 10b.** Switching Time Waveforms

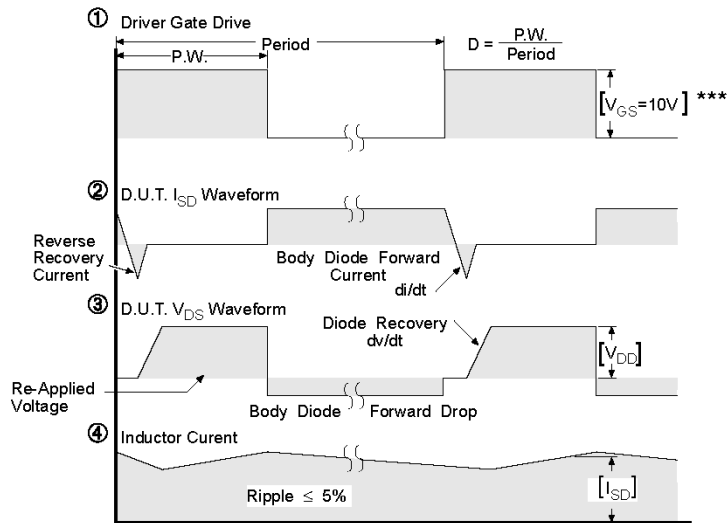


**Fig 11.** Maximum Effective Transient Thermal Impedance, Junction-to-Ambient

## Peak Diode Recovery dv/dt Test Circuit



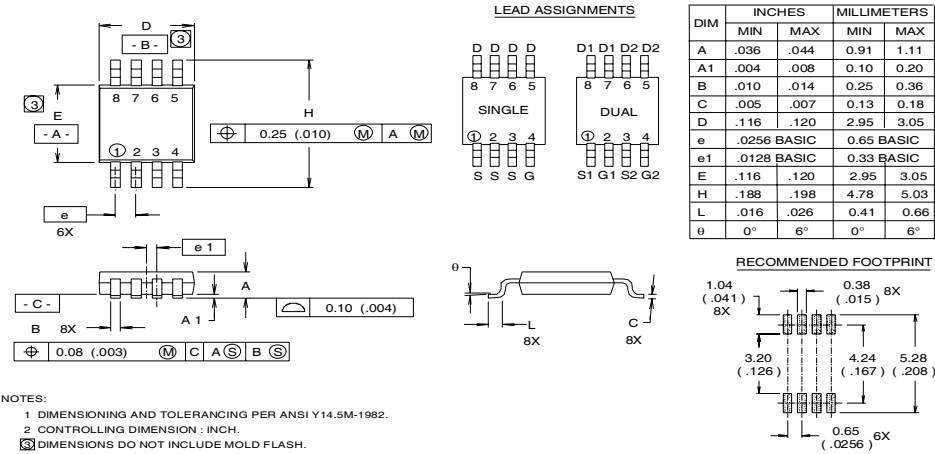
\* Reverse Polarity of D.U.T. for P-Channel



\*\*\*  $V_{GS} = 5.0V$  for Logic Level and 3V Drive Devices

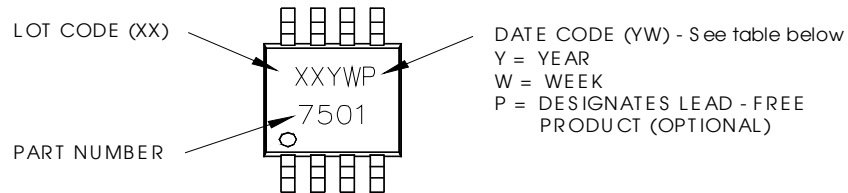
**Fig 12.** For P-Channel HEXFETS

## Micro8 Package Outline



## Micro8 Part Marking Information

EXAMPLE: THIS IS AN IRF7501



WW = (1-26) IF PRECEDED BY LAST DIGIT OF CALENDAR YEAR

| YEAR | Y | WORK WEEK | W |
|------|---|-----------|---|
| 2001 | 1 | 01        | A |
| 2002 | 2 | 02        | B |
| 2003 | 3 | 03        | C |
| 2004 | 4 | 04        | D |
| 2005 | 5 |           |   |
| 2006 | 6 |           |   |
| 2007 | 7 |           |   |
| 2008 | 8 |           |   |
| 2009 | 9 |           |   |
| 2010 | 0 | 24        | X |
|      |   | 25        | Y |
|      |   | 26        | Z |

WW = (27-52) IF PRECEDED BY A LETTER

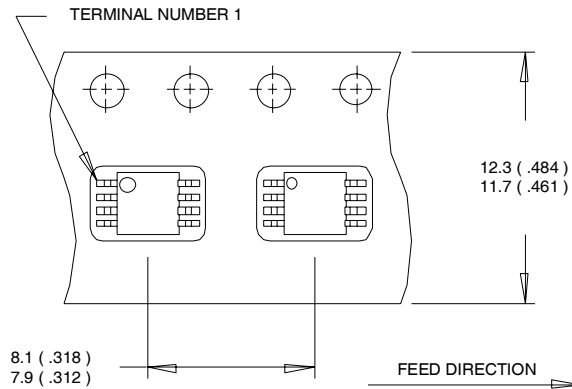
| YEAR | Y | WORK WEEK | W |
|------|---|-----------|---|
| 2001 | A | 27        | A |
| 2002 | B | 28        | B |
| 2003 | C | 29        | C |
| 2004 | D | 30        | D |
| 2005 | E |           |   |
| 2006 | F |           |   |
| 2007 | G |           |   |
| 2008 | H |           |   |
| 2009 | J |           |   |
| 2010 | K | 50        | X |
|      |   | 51        | Y |
|      |   | 52        | Z |

# IRF7506PbF

## Micro8 Tape & Reel Information

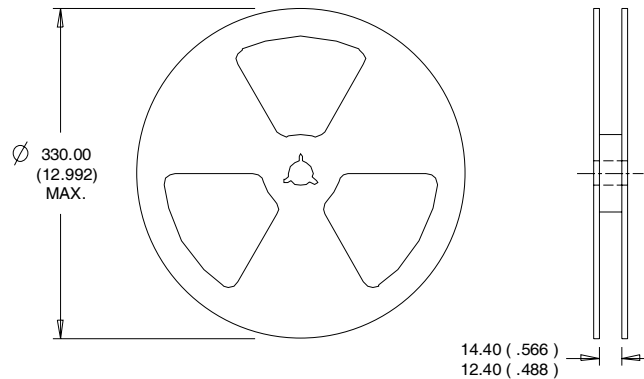
Dimensions are shown in millimeters (inches)

International  
**IR** Rectifier



### NOTES:

1. OUTLINE CONFORMS TO EIA-481 & EIA-541.
2. CONTROLLING DIMENSION : MILLIMETER.



### NOTES :

1. CONTROLLING DIMENSION : MILLIMETER.
2. OUTLINE CONFORMS TO EIA-481 & EIA-541.

Data and specifications subject to change without notice.  
This product has been designed and qualified for the Consumer market.  
Qualification Standards can be found on IR's Web site.

International  
**IR** Rectifier

**IR WORLD HEADQUARTERS:** 233 Kansas St., El Segundo, California 90245, USA Tel: (310) 252-7105  
TAC Fax: (310) 252-7903

Visit us at [www.irf.com](http://www.irf.com) for sales contact information.09/04  
[www.irf.com](http://www.irf.com)

## **IMPORTANT NOTICE**

The information given in this document shall in no event be regarded as a guarantee of conditions or characteristics ("Beschaffheitsgarantie").

With respect to any examples, hints or any typical values stated herein and/or any information regarding the application of the product, Infineon Technologies hereby disclaims any and all warranties and liabilities of any kind, including without limitation warranties of non-infringement of intellectual property rights of any third party.

In addition, any information given in this document is subject to customer's compliance with its obligations stated in this document and any applicable legal requirements, norms and standards concerning customer's products and any use of the product of Infineon Technologies in customer's applications.

The data contained in this document is exclusively intended for technically trained staff. It is the responsibility of customer's technical departments to evaluate the suitability of the product for the intended application and the completeness of the product information given in this document with respect to such application.

For further information on the product, technology, delivery terms and conditions and prices please contact your nearest Infineon Technologies office ([www.infineon.com](http://www.infineon.com)).

## **WARNINGS**

Due to technical requirements products may contain dangerous substances. For information on the types in question please contact your nearest Infineon Technologies office.

Except as otherwise explicitly approved by Infineon Technologies in a written document signed by authorized representatives of Infineon Technologies, Infineon Technologies' products may not be used in any applications where a failure of the product or any consequences of the use thereof can reasonably be expected to result in personal injury.

## Looking for pricing, stock, or lifecycle information?

Click below to explore more details on WIN SOURCE:

 [View IRF7506TRPBF on WIN SOURCE](#)

 [Infineon Technologies](#) Information

## Optimize Your Supply Chain with WIN SOURCE Solutions

-  Global Sourcing Solution
-  Obsolete Management
-  Cost Control Management
-  Shortage Management
-  Alternative Solution
-  Excess Inventory Management