



**THE DATASHEET OF
IRFH9310TRPBF**



HEXFET® Power MOSFET

V_{DS}	-30	V
$R_{DS(on) \text{ max}}$ (@ $V_{GS} = 10V$)	4.6	mΩ
Q_g (typical)	110	nC
R_G (typical)	2.8	Ω
I_D (@ $T_A = 25^\circ C$)	-21	A

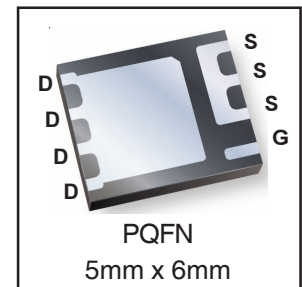
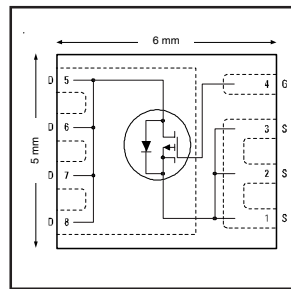

Applications

- Charge and Discharge Switch for Notebook PC Battery Application

Features and Benefits

Features

Low $R_{DS(on)} (\leq 4.6m\Omega)$
Industry-Standard PQFN Package
RoHS Compliant Containing no Lead, no Bromide and no Halogen

results in
⇒

Resulting Benefits

Lower Conduction Losses
Multi-Vendor Compatibility
Environmentally Friendlier

Orderable part number	Package Type	Standard Pack		Note
		Form	Quantity	
IRFH9310TRPBF	PQFN 5mm x 6mm	Tape and Reel	4000	

Absolute Maximum Ratings

	Parameter	Max.	Units
V_{DS}	Drain-to-Source Voltage	-30	V
V_{GS}	Gate-to-Source Voltage	± 20	
$I_D @ T_A = 25^\circ C$	Continuous Drain Current, $V_{GS} @ -10V$	-21	A
$I_D @ T_A = 70^\circ C$	Continuous Drain Current, $V_{GS} @ -10V$	-17	
$I_D @ T_C = 25^\circ C$	Continuous Drain Current, $V_{GS} @ -10V$ (Silicon Limited)	-107	
$I_D @ T_C = 70^\circ C$	Continuous Drain Current, $V_{GS} @ -10V$ (Silicon Limited)	- 86	
$I_D @ T_C = 25^\circ C$	Continuous Drain Current, $V_{GS} @ -10V$ (Package Limited)	-40	
I_{DM}	Pulsed Drain Current ①	-170	
$P_D @ T_A = 25^\circ C$	Power Dissipation ④	3.1	W
$P_D @ T_A = 70^\circ C$	Power Dissipation ④	2.0	
	Linear Derating Factor	0.025	W/°C
T_J	Operating Junction and	-55 to + 150	°C
T_{STG}	Storage Temperature Range		

Notes ① through ④ are on page 2

Static @ T_J = 25°C (unless otherwise specified)

	Parameter	Min.	Typ.	Max.	Units	Conditions
BV _{DSS}	Drain-to-Source Breakdown Voltage	-30	—	—	V	V _{GS} = 0V, I _D = -250μA
ΔBV _{DSS} /ΔT _J	Breakdown Voltage Temp. Coefficient	—	0.020	—	V/°C	Reference to 25°C, I _D = -1mA
R _{DS(on)}	Static Drain-to-Source On-Resistance	—	3.7	4.6	mΩ	V _{GS} = -10V, I _D = -21A ③
		—	5.7	7.1		V _{GS} = -4.5V, I _D = -17A ③
V _{GS(th)}	Gate Threshold Voltage	-1.3	-1.9	-2.4	V	V _{DS} = V _{GS} , I _D = -100μA
ΔV _{GS(th)}	Gate Threshold Voltage Coefficient	—	-5.8	—	mV/°C	
I _{DSS}	Drain-to-Source Leakage Current	—	—	-1.0	μA	V _{DS} = -24V, V _{GS} = 0V
		—	—	-150		V _{DS} = -24V, V _{GS} = 0V, T _J = 125°C
I _{GSS}	Gate-to-Source Forward Leakage	—	—	-100	nA	V _{GS} = -20V
	Gate-to-Source Reverse Leakage	—	—	100		V _{GS} = 20V
g _{fs}	Forward Transconductance	39	—	—	S	V _{DS} = -10V, I _D = -17A
Q _g	Total Gate Charge ⑥	—	58	—	nC	V _{DS} = -15V, V _{GS} = -4.5V, I _D = -17A
Q _g	Total Gate Charge ⑥	—	110	165	nC	V _{DS} = -10V
Q _{gs}	Gate-to-Source Charge ⑥	—	17	—		V _{DS} = -15V
Q _{gd}	Gate-to-Drain Charge ⑥	—	28	—		I _D = -17A
R _G	Gate Resistance ⑥	—	2.8	—	Ω	
t _{d(on)}	Turn-On Delay Time	—	25	—	ns	V _{DD} = -15V, V _{GS} = -4.5V ③
t _r	Rise Time	—	47	—		I _D = -1.0A
t _{d(off)}	Turn-Off Delay Time	—	65	—		R _G = 1.8Ω
t _f	Fall Time	—	70	—		See Figs. 19a & 19b
C _{iss}	Input Capacitance	—	5250	—	pF	V _{GS} = 0V
C _{oss}	Output Capacitance	—	1300	—		V _{DS} = -15V
C _{rss}	Reverse Transfer Capacitance	—	880	—		f = 1.0MHz

Avalanche Characteristics

	Parameter	Typ.	Max.	Units
E _{AS}	Single Pulse Avalanche Energy ②	—	170	mJ
I _{AR}	Avalanche Current ①	—	-17	A

Diode Characteristics

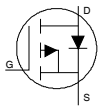
	Parameter	Min.	Typ.	Max.	Units	Conditions
I _S	Continuous Source Current (Body Diode)	—	—	-3.1	A	MOSFET symbol showing the integral reverse p-n junction diode. 
I _{SM}	Pulsed Source Current (Body Diode) ①	—	—	-170		
V _{SD}	Diode Forward Voltage	—	—	-1.2	V	T _J = 25°C, I _S = -3.1A, V _{GS} = 0V ③
t _{rr}	Reverse Recovery Time	—	42	63	ns	T _J = 25°C, I _F = -3.1A, V _{DD} = -24V
Q _{rr}	Reverse Recovery Charge	—	42	63	nC	di/dt = 100/μs ③

Thermal Resistance

	Parameter	Typ.	Max.	Units
R _{θJC}	Junction-to-Case ⑤	—	1.6	°C/W
R _{θJA}	Junction-to-Ambient ④	—	40	
R _{θJA}	Junction-to-Ambient (t < 10s) ④	—	35	

Notes:

- ① Repetitive rating; pulse width limited by max. junction temperature.
- ② Starting T_J = 25°C, L = 1.1mH, R_G = 50Ω, I_{AS} = -17A.
- ③ Pulse width ≤ 400μs; duty cycle ≤ 2%.
- ④ When mounted on 1 inch square copper board.
- ⑤ R_θ is measured at T_J of approximately 90°C.
- ⑥ For DESIGN AID ONLY, not subject to production testing.

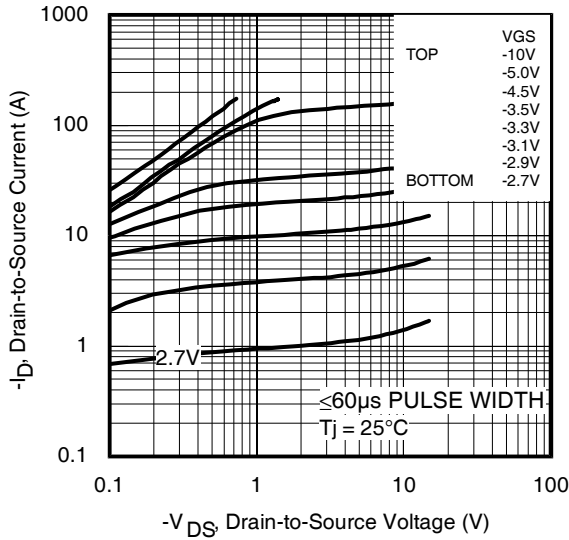
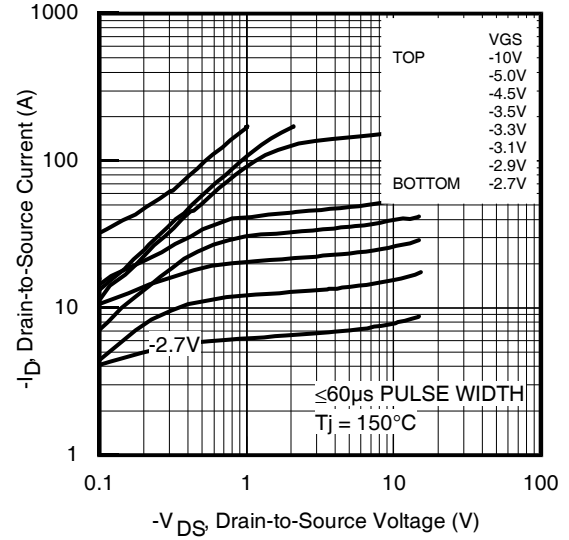
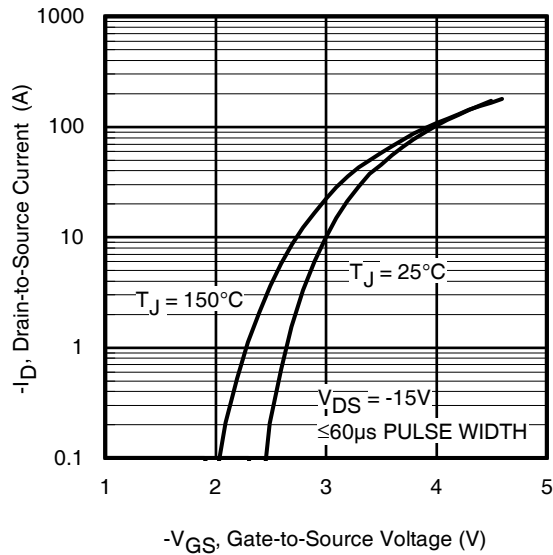
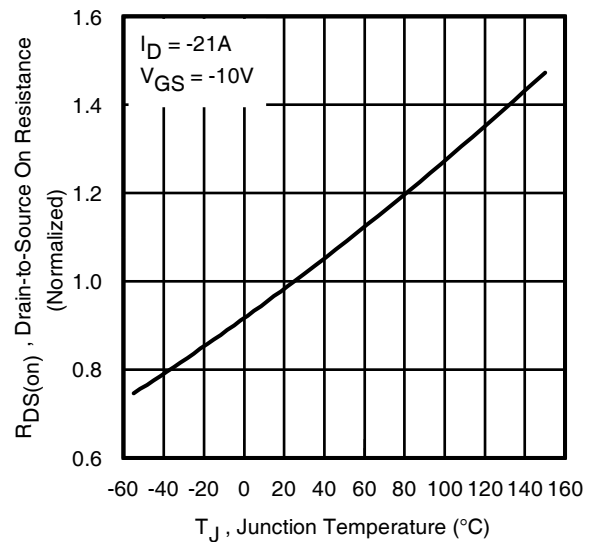
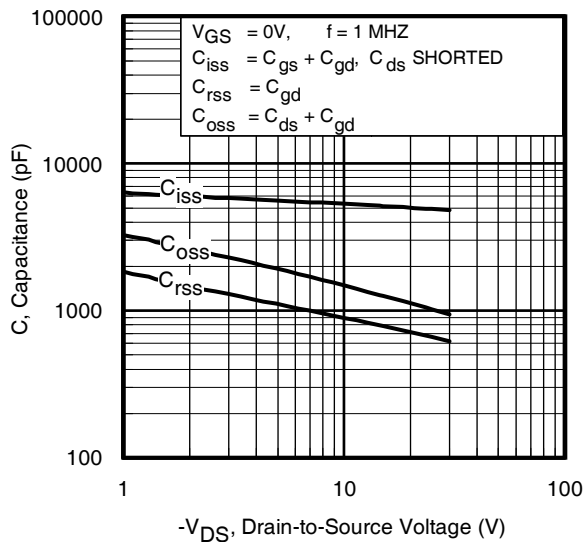
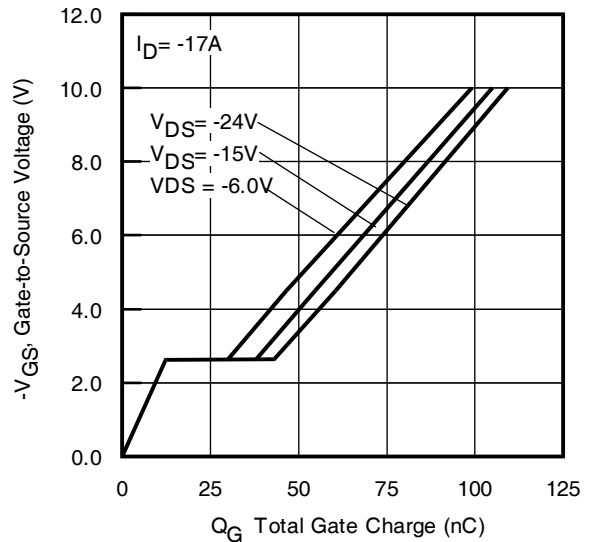
Fig 1. Typical Output Characteristics

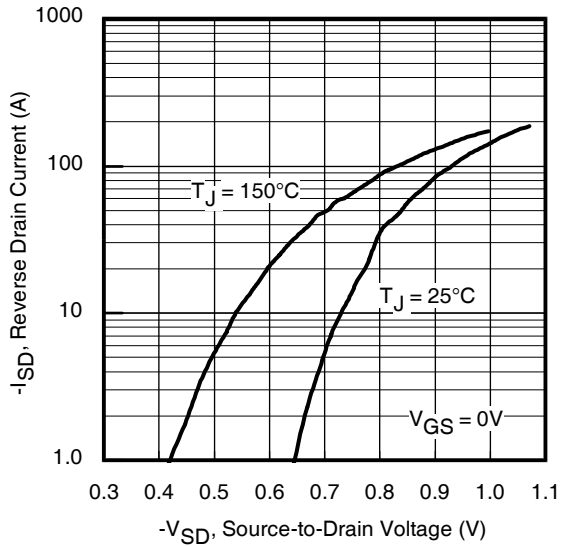
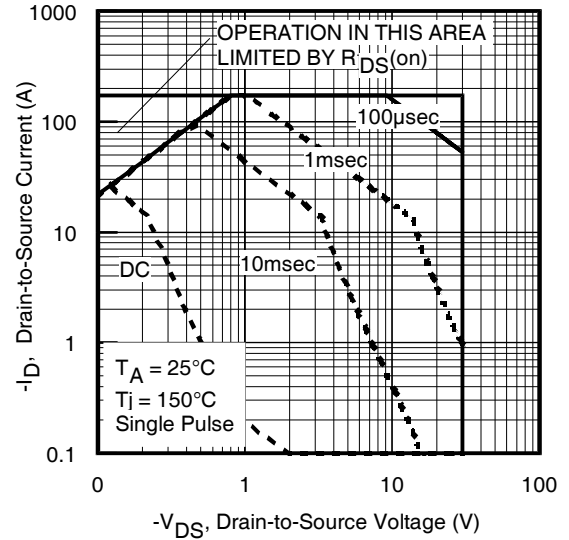
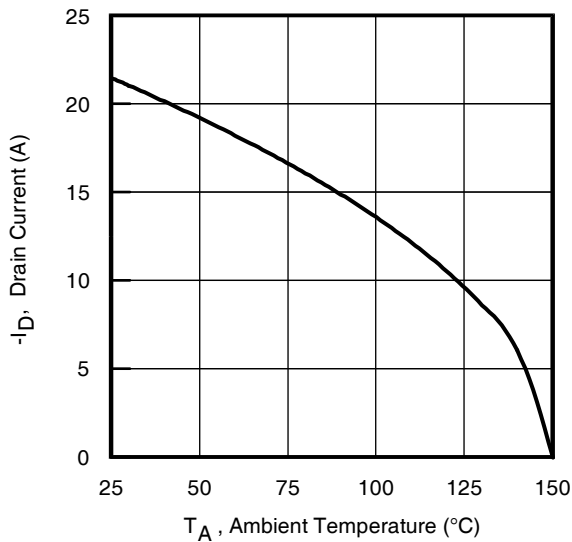
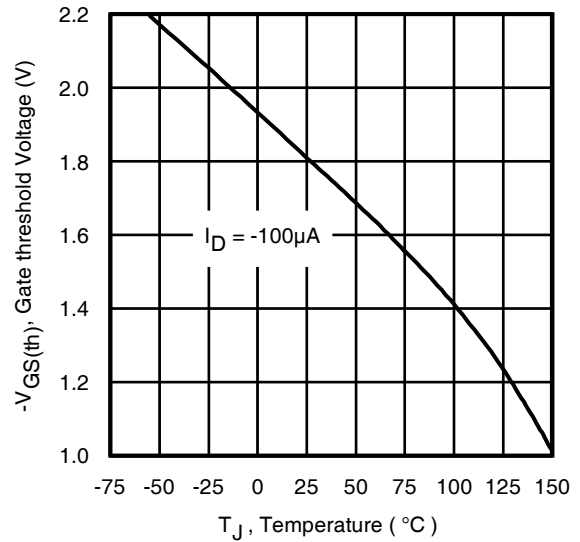
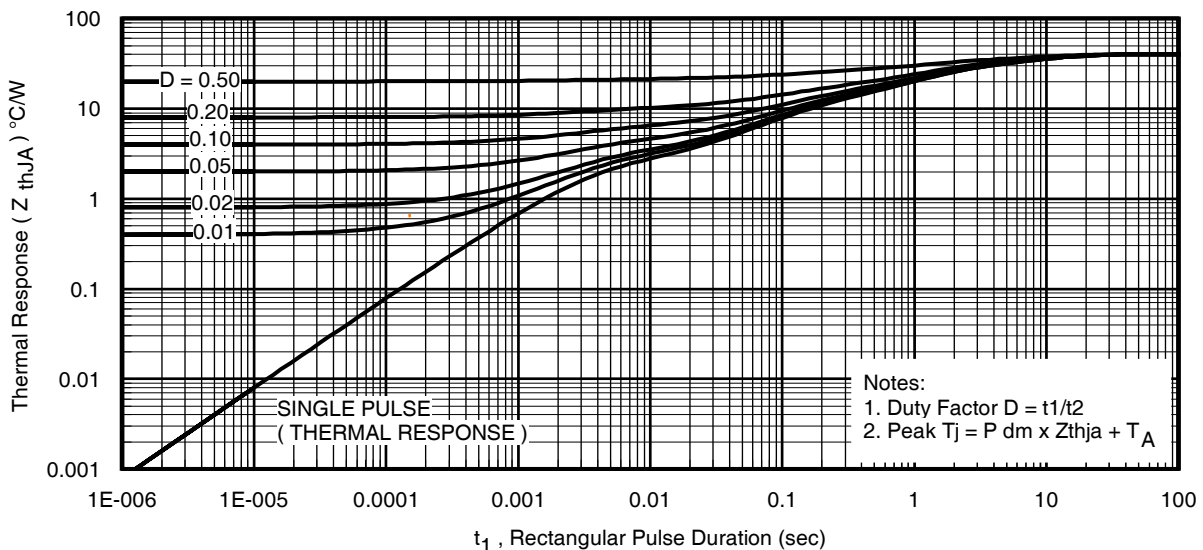
Fig 2. Typical Output Characteristics

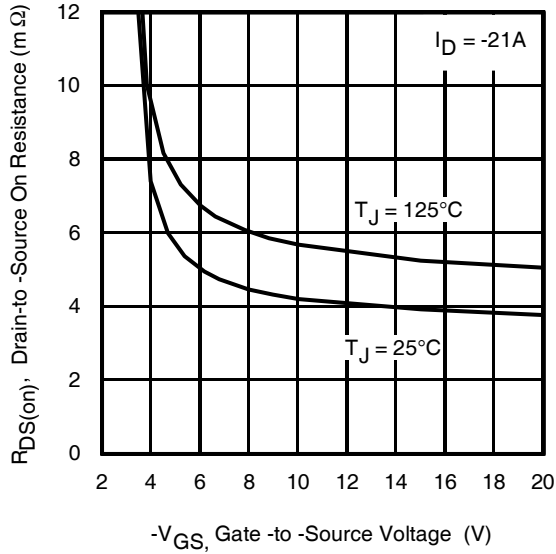
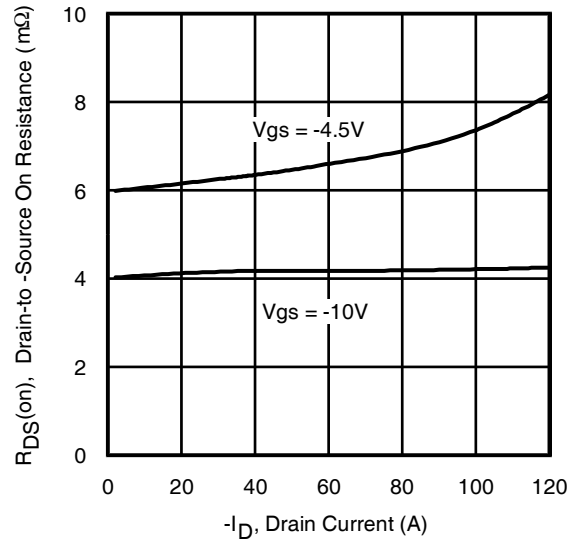
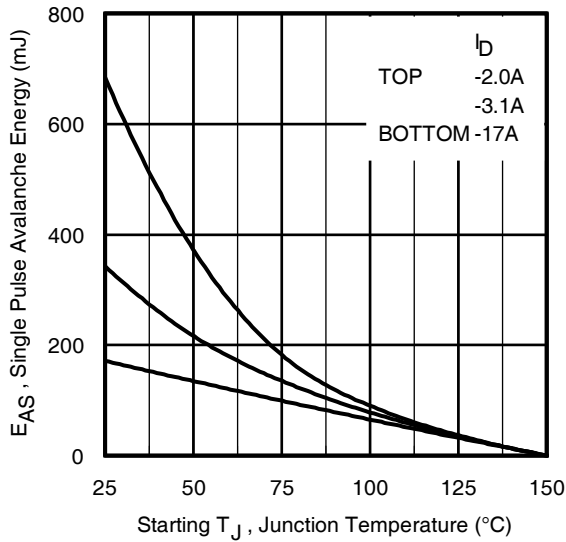
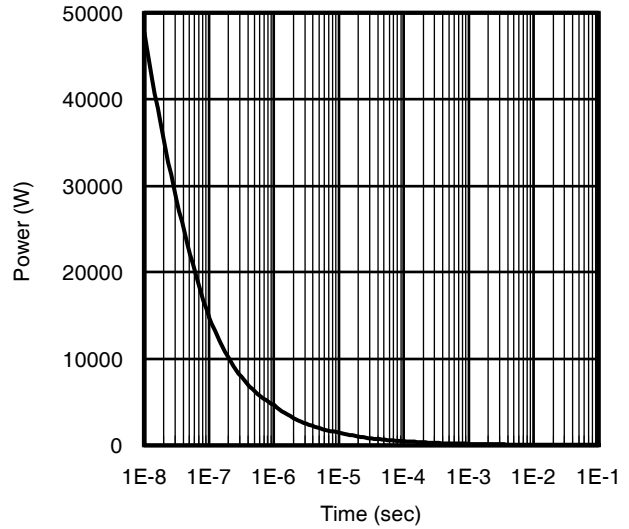
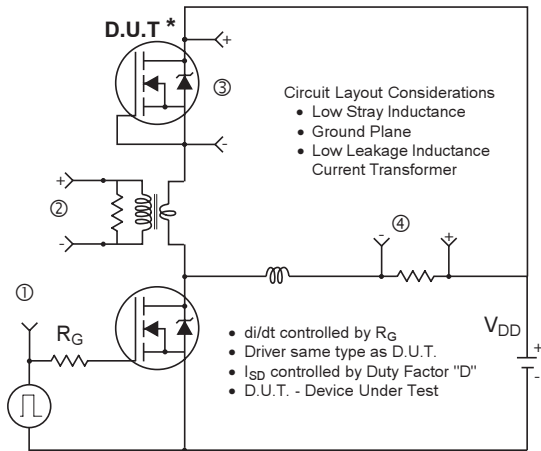
Fig 3. Typical Transfer Characteristics

Fig 4. Normalized On-Resistance vs. Temperature

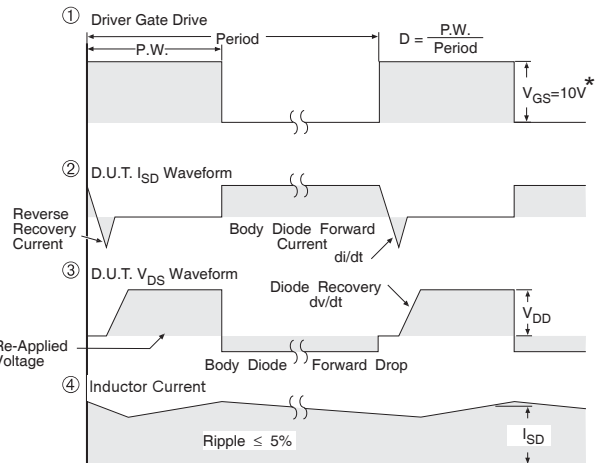
Fig 5. Typical Capacitance vs. Drain-to-Source Voltage

Fig 6. Typical Gate Charge vs. Gate-to-Source Voltage

Fig 7. Typical Source-Drain Diode Forward Voltage

Fig 8. Maximum Safe Operating Area

Fig 9. Maximum Drain Current vs. Ambient Temperature

Fig 10. Threshold Voltage vs. Temperature

Fig 11. Maximum Effective Transient Thermal Impedance, Junction-to-Ambient

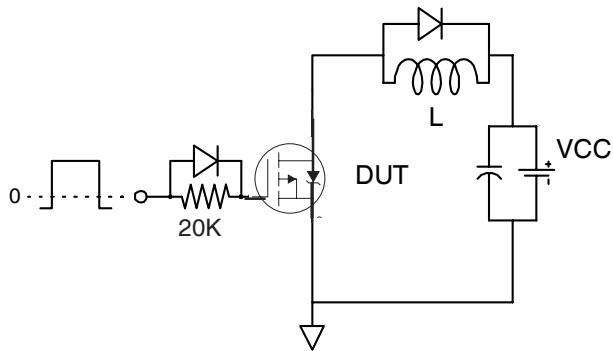
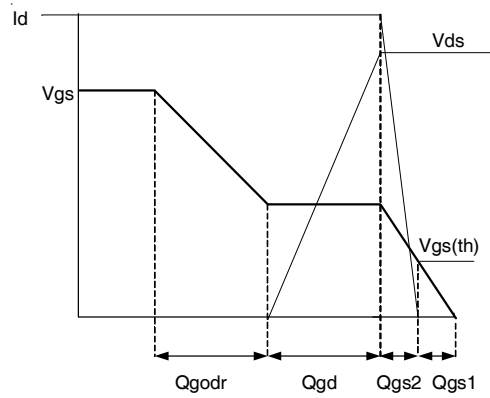
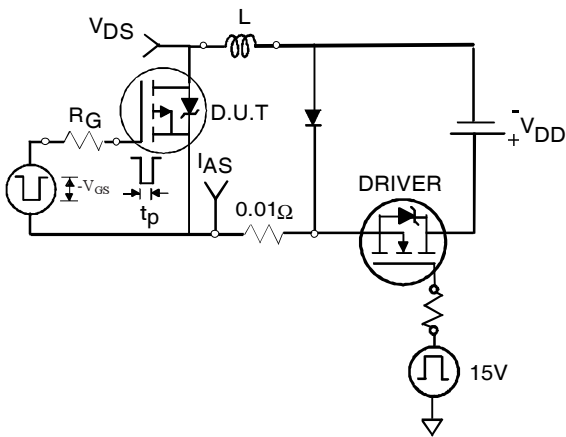
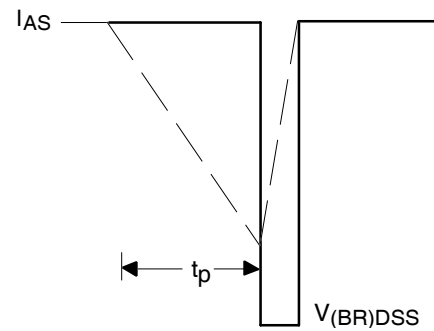
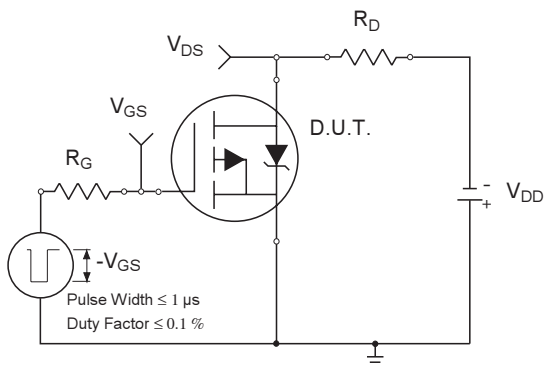
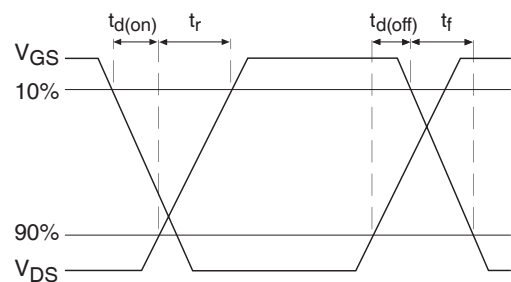

Fig 12. On-Resistance vs. Gate Voltage

Fig 13. Typical On-Resistance vs. Drain Current

Fig 14. Maximum Avalanche Energy vs. Drain Current

Fig 15. Typical Power vs. Time

* Reverse Polarity of D.U.T for P-Channel



* $V_{GS} = 5V$ for Logic Level Devices

Fig 16. Diode Reverse Recovery Test Circuit for P-Channel HEXFET® Power MOSFETs

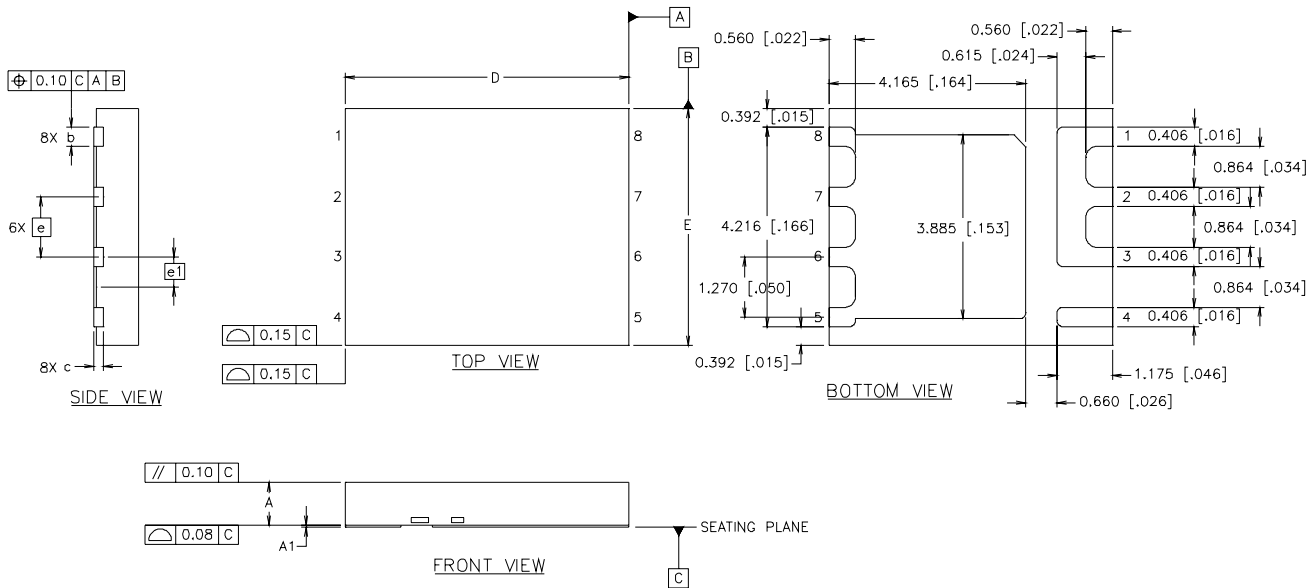
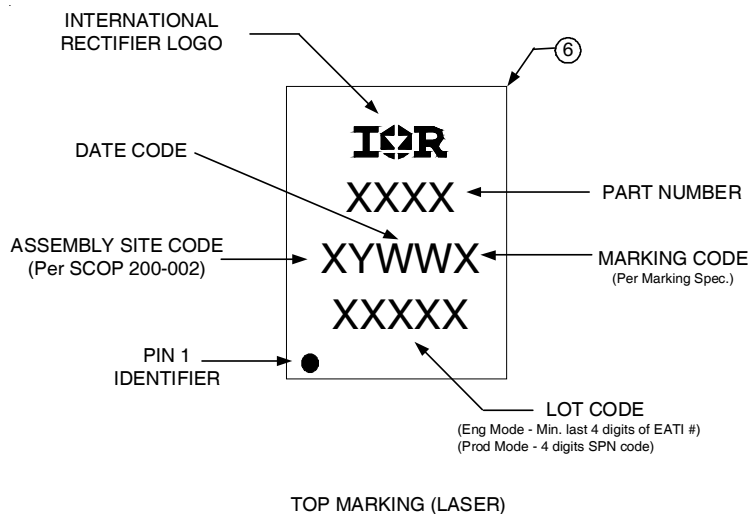

Fig 17a. Gate Charge Test Circuit

Fig 17b. Gate Charge Waveform

Fig 18a. Unclamped Inductive Test Circuit

Fig 18b. Unclamped Inductive Waveforms

Fig 19a. Switching Time Test Circuit

Fig 19b. Switching Time Waveforms

PQFN Package Details



DIM	INCHES		MILLIMETERS	
	MIN	MAX	MIN	MAX
A	.0315	.0394	0.800	1.000
A1	.0000	.0020	0.000	0.050
b	.0140	.0180	0.356	0.456
c	.0080 REF.		0.203 REF.	
D	.2362 BASIC		6.0 BASIC	
E	.1969 BASIC		5.0 BASIC	
e	.0500 BASIC		1.270 BASIC	
e1	.0250 BASIC		0.635 BASIC	

PQFN Part Marking



Note: For the most current drawing please refer to IR website at: <http://www.irf.com/package/>

PQFN Tape and Reel

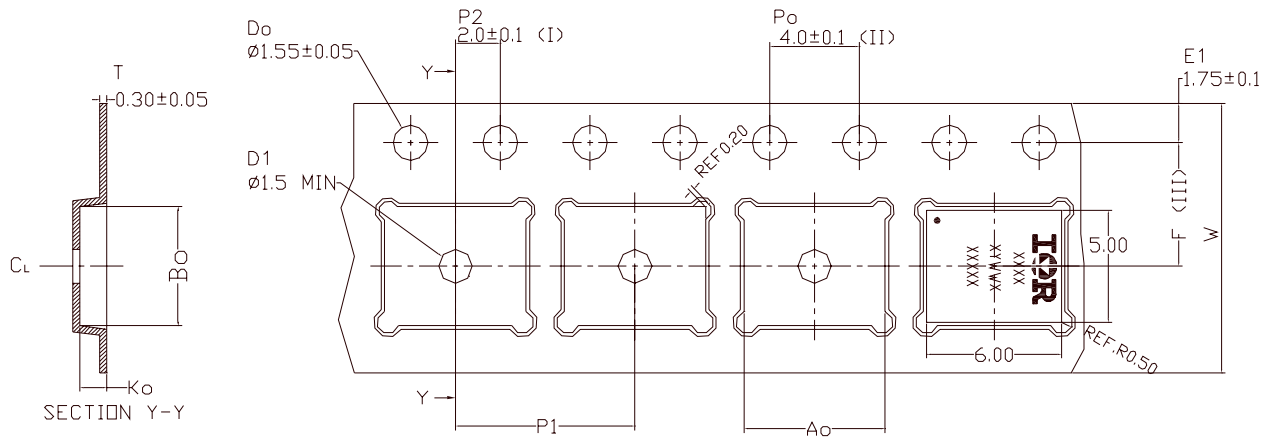

Ao	6.30 +/- 0.1
Bo	5.30 +/- 0.1
Ko	1.20 +/- 0.1
F	5.50 +/- 0.1
P1	8.00 +/- 0.1
W	12.00 +/- 0.3

(I) Measured from centerline of sprocket hole to centerline of pocket.

(II) Cumulative tolerance of 10 sprocket hole is ± 0.20 .

(III) Measured from centerline of sprocket hole to centerline of pocket.

(IV) Other material available.

(V) Typical SR of form tape Max 10^9 DHM/SQ.

ALL DIMENSIONS IN MILLIMETERS UNLESS OTHERWISE STATED.

Note: For the most current drawing please refer to IR website at: <http://www.irf.com/package/>

Qualification Information[†]

Qualification level	Consumer ^{††}	
	(per JEDEC JESD47F ^{†††} guidelines)	
Moisture Sensitivity Level	PQFN 5mm x 6mm	MSL2 (per JEDEC J-STD-020D ^{†††})
RoHS Compliant	Yes	

† Qualification standards can be found at International Rectifier’s web site

<http://www.irf.com/product-info/reliability>

†† Higher qualification ratings may be available should the user have such requirements.

Please contact your International Rectifier sales representative for further information:

<http://www.irf.com/whoto-call/salesrep/>

††† Applicable version of JEDEC standard at the time of product release.

†††† Higher MSL ratings may be available for the specific package types listed here. Please contact your

International Rectifier sales representative for further information: <http://www.irf.com/whoto-call/salesrep/>

Revision History

Date	Comments
8/19/2014	<ul style="list-style-type: none"> • Updated datasheet as per new IR Corporate Template • Updated data sheet with latest PQFN Tape and Reel Diagram.

Looking for pricing, stock, or lifecycle information?

Click below to explore more details on WIN SOURCE:

 [View IRFH9310TRPBF on WIN SOURCE](#)

 [Infineon Technologies](#) Information

Optimize Your Supply Chain with WIN SOURCE Solutions

-  Global Sourcing Solution
-  Obsolete Management
-  Cost Control Management
-  Shortage Management
-  Alternative Solution
-  Excess Inventory Management