



**Applications**

- High Efficiency Synchronous Rectification in SMPS
- Uninterruptible Power Supply
- High Speed Power Switching
- Hard Switched and High Frequency Circuits

**Benefits**

- Improved Gate, Avalanche and Dynamic dV/dt Ruggedness
- Fully Characterized Capacitance and Avalanche SOA
- Enhanced body diode dV/dt and dI/dt Capability
- Lead-Free

HEXFET® Power MOSFET

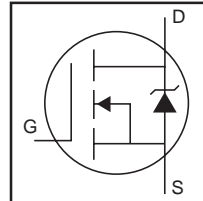

|                                |              |
|--------------------------------|--------------|
| <b>V<sub>DSS</sub></b>         | <b>100V</b>  |
| <b>R<sub>DS(on)</sub> typ.</b> | <b>5.6mΩ</b> |
|                                | <b>7.0mΩ</b> |
| <b>I<sub>D</sub></b>           | <b>130A</b>  |



**Absolute Maximum Ratings**

| Symbol                                  | Parameter  | Max.             | Units |
|---|--|------------------|-------|
| I <sub>D</sub> @ T <sub>C</sub> = 25°C  | Continuous Drain Current, V <sub>GS</sub> @ 10V            | 130①             | A     |
| I <sub>D</sub> @ T <sub>C</sub> = 100°C | Continuous Drain Current, V <sub>GS</sub> @ 10V            | 92①              |       |
| I <sub>DM</sub>                         | Pulsed Drain Current ②                                     | 550              |       |
| P <sub>D</sub> @ T <sub>C</sub> = 25°C  | Maximum Power Dissipation                                  | 300              | W     |
|   | Linear Derating Factor                                     | 2.0              | W/°C  |
| V <sub>GS</sub>                         | Gate-to-Source Voltage                                     | ± 20             | V     |
| dV/dt                                   | Peak Diode Recovery ④                                      | 14               | V/ns  |
| T <sub>J</sub>                          | Operating Junction and                                     | -55 to + 175     | °C    |
| T <sub>STG</sub>                        | Storage Temperature Range                                  |                  |       |
|   | Soldering Temperature, for 10 seconds<br>(1.6mm from case) | 300              |       |
|   | Mounting torque, 6-32 or M3 screw                          | 10lb·in (1.1N·m) |       |

**Avalanche Characteristics**

|                                     |                                 |                            |    |
|-------------------------------------|---------------------------------|----------------------------|----|
| E <sub>AS</sub> (Thermally limited) | Single Pulse Avalanche Energy ③ | 980                        | mJ |
| I <sub>AR</sub>                     | Avalanche Current ①             | See Fig. 14, 15, 22a, 22b, | A  |
| E <sub>AR</sub>                     | Repetitive Avalanche Energy ⑤   |                            | mJ |

**Thermal Resistance**

| Symbol           | Parameter                                   | Typ. | Max. | Units |
|------------------|---|------|------|-------|
| R <sub>θJC</sub> | Junction-to-Case ⑥                          | —    | 0.50 | °C/W  |
| R <sub>θCS</sub> | Case-to-Sink, Flat Greased Surface , TO-220 | 0.50 | —    |       |
| R <sub>θJA</sub> | Junction-to-Ambient, TO-220 ⑦               | —    | 62   |       |
| R <sub>θJA</sub> | Junction-to-Ambient (PCB Mount) , D²Pak ⑧⑨  | —    | 40   |       |

**Static @ T<sub>J</sub> = 25°C (unless otherwise specified)**

| Symbol                               | Parameter                            | Min. | Typ.  | Max. | Units | Conditions   |
|--------------------------------------|--------------------------------------|------|-------|------|-------|--|
| V <sub>(BR)DSS</sub>                 | Drain-to-Source Breakdown Voltage    | 100  | —     | —    | V     | V <sub>GS</sub> = 0V, I <sub>D</sub> = 250μA                         |
| ΔV <sub>(BR)DSS/ΔT<sub>J</sub></sub> | Breakdown Voltage Temp. Coefficient  | —    | 0.064 | —    | V/°C  | Reference to 25°C, I <sub>D</sub> = 1mAⓉ                             |
| R <sub>DS(on)</sub>                  | Static Drain-to-Source On-Resistance | —    | 5.6   | 7.0  | mΩ    | V <sub>GS</sub> = 10V, I <sub>D</sub> = 75A Ⓢ                        |
| V <sub>GS(th)</sub>                  | Gate Threshold Voltage               | 2.0  | —     | 4.0  | V     | V <sub>DS</sub> = V <sub>GS</sub> , I <sub>D</sub> = 250μA           |
| I <sub>DSS</sub>                     | Drain-to-Source Leakage Current      | —    | —     | 20   | μA    | V <sub>DS</sub> = 100V, V <sub>GS</sub> = 0V                         |
|                                      |                                      | —    | —     | 250  |       | V <sub>DS</sub> = 100V, V <sub>GS</sub> = 0V, T <sub>J</sub> = 125°C |
| I <sub>GSS</sub>                     | Gate-to-Source Forward Leakage       | —    | —     | 200  | nA    | V <sub>GS</sub> = 20V  |
|                                      | Gate-to-Source Reverse Leakage       | —    | —     | -200 |       | V <sub>GS</sub> = -20V   |
| R <sub>G</sub>                       | Gate Input Resistance                | —    | 1.4   | —    | Ω     | f = 1MHz, open drain   |

**Dynamic @ T<sub>J</sub> = 25°C (unless otherwise specified)**

| Symbol                     | Parameter                                      | Min. | Typ.  | Max. | Units | Conditions  |
|----------------------------|--|------|-------|------|-------|---|
| gfs                        | Forward Transconductance                       | 160  | —     | —    | S     | V <sub>DS</sub> = 50V, I <sub>D</sub> = 75A                     |
| Q <sub>g</sub>             | Total Gate Charge                              | —    | 170   | 250  | nC    | I <sub>D</sub> = 75A  |
| Q <sub>gs</sub>            | Gate-to-Source Charge                          | —    | 46    | —    |       | V <sub>DS</sub> = 80V   |
| Q <sub>gd</sub>            | Gate-to-Drain ("Miller") Charge                | —    | 62    | —    |       | V <sub>GS</sub> = 10V Ⓢ   |
| t <sub>d(on)</sub>         | Turn-On Delay Time                             | —    | 26    | —    | ns    | V <sub>DD</sub> = 65V   |
| t <sub>r</sub>             | Rise Time                                      | —    | 110   | —    |       | I <sub>D</sub> = 75A  |
| t <sub>d(off)</sub>        | Turn-Off Delay Time                            | —    | 68    | —    |       | R <sub>G</sub> = 2.6Ω   |
| t <sub>f</sub>             | Fall Time                                      | —    | 78    | —    |       | V <sub>GS</sub> = 10V Ⓢ   |
| C <sub>iss</sub>           | Input Capacitance                              | —    | 7670  | —    | pF    | V <sub>GS</sub> = 0V  |
| C <sub>oss</sub>           | Output Capacitance                             | —    | 540   | —    |       | V <sub>DS</sub> = 50V   |
| C <sub>rss</sub>           | Reverse Transfer Capacitance                   | —    | 280   | —    |       | f = 1.0MHz  |
| C <sub>oss eff. (ER)</sub> | Effective Output Capacitance (Energy Related)Ⓣ | —    | 650   | —    |       | V <sub>GS</sub> = 0V, V <sub>DS</sub> = 0V to 80V Ⓢ, See Fig.11 |
| C <sub>oss eff. (TR)</sub> | Effective Output Capacitance (Time Related)Ⓢ   | —    | 720.1 | —    |       | V <sub>GS</sub> = 0V, V <sub>DS</sub> = 0V to 80V Ⓢ, See Fig. 5 |

**Diode Characteristics**

| Symbol           | Parameter                                 | Min.   | Typ. | Max. | Units | Conditions  |
|------------------|---|--|------|------|-------|---|
| I <sub>S</sub>   | Continuous Source Current<br>(Body Diode) | —  | —    | 130Ⓣ | A     | MOSFET symbol<br>showing the<br>integral reverse<br>p-n junction diode. |
| I <sub>SM</sub>  | Pulsed Source Current<br>(Body Diode) ⓉⓉ  | —  | —    | 550  |       |   |
| V <sub>SD</sub>  | Diode Forward Voltage                     | —  | —    | 1.3  | V     | T <sub>J</sub> = 25°C, I <sub>S</sub> = 75A, V <sub>GS</sub> = 0V Ⓢ     |
| t <sub>rr</sub>  | Reverse Recovery Time                     | —  | 45   | 68   | ns    | T <sub>J</sub> = 25°C V <sub>R</sub> = 85V,                             |
|                  |   | —  | 55   | 83   |       | T <sub>J</sub> = 125°C I <sub>F</sub> = 75A                             |
| Q <sub>rr</sub>  | Reverse Recovery Charge                   | —  | 82   | 120  | nC    | T <sub>J</sub> = 25°C di/dt = 100A/μs Ⓢ                                 |
|                  |   | —  | 120  | 180  |       | T <sub>J</sub> = 125°C  |
| I <sub>RRM</sub> | Reverse Recovery Current                  | —  | 3.3  | —    | A     | T <sub>J</sub> = 25°C   |
| t <sub>on</sub>  | Forward Turn-On Time                      | Intrinsic turn-on time is negligible (turn-on is dominated by LS+LD) |      |      |       |   |

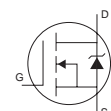

**Notes:**

- ① Calculated continuous current based on maximum allowable junction temperature. Package limitation current is 75A
- ② Repetitive rating; pulse width limited by max. junction temperature.
- ③ Limited by T<sub>Jmax</sub>, starting T<sub>J</sub> = 25°C, L = 0.35mH  
R<sub>G</sub> = 25Ω, I<sub>AS</sub> = 75A, V<sub>GS</sub> = 10V. Part not recommended for use above this value.
- ④ I<sub>SD</sub> ≤ 75A, di/dt ≤ 550A/μs, V<sub>DD</sub> ≤ V<sub>(BR)DSS</sub>, T<sub>J</sub> ≤ 175°C.
- ⑤ Pulse width ≤ 400μs; duty cycle ≤ 2%.
- Ⓢ C<sub>oss eff. (TR)</sub> is a fixed capacitance that gives the same charging time as C<sub>oss</sub> while V<sub>DS</sub> is rising from 0 to 80% V<sub>DSS</sub>.
- Ⓣ C<sub>oss eff. (ER)</sub> is a fixed capacitance that gives the same energy as C<sub>oss</sub> while V<sub>DS</sub> is rising from 0 to 80% V<sub>DSS</sub>.
- Ⓢ When mounted on 1" square PCB (FR-4 or G-10 Material). For recommended footprint and soldering techniques refer to application note #AN-994.
- Ⓢ R<sub>θ</sub> is measured at T<sub>J</sub> approximately 90°C.

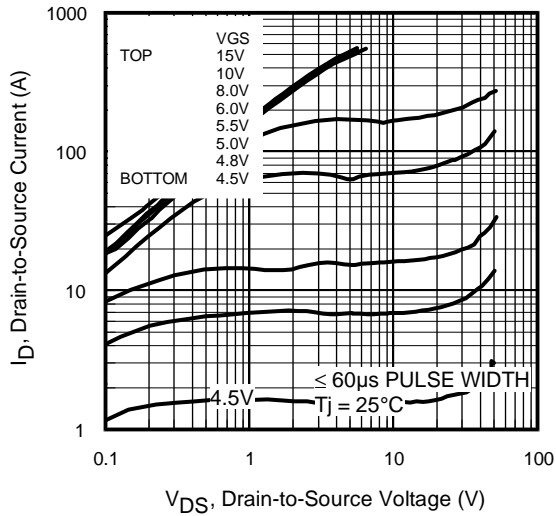

Fig 1. Typical Output Characteristics

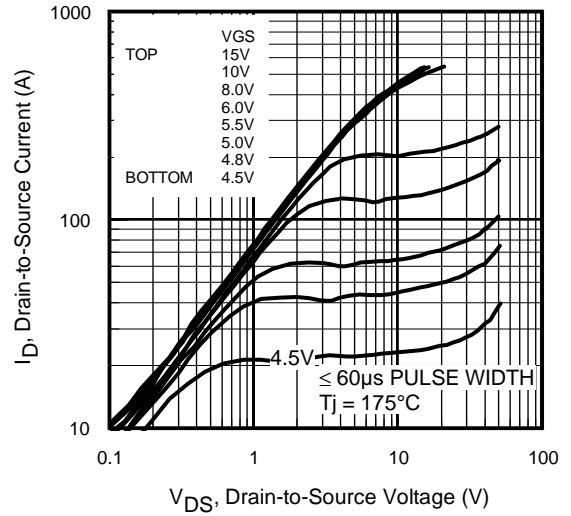

Fig 2. Typical Output Characteristics

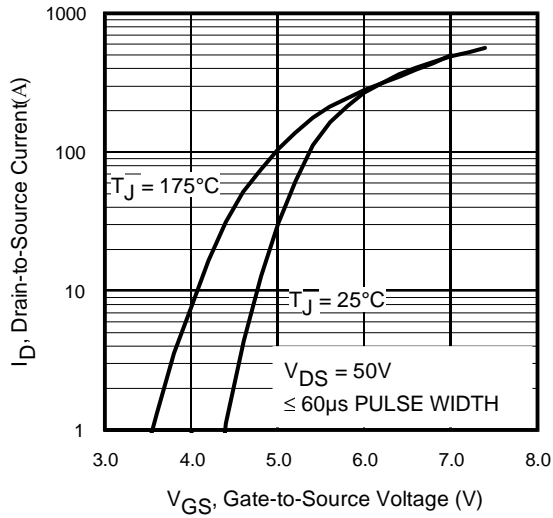

Fig 3. Typical Transfer Characteristics

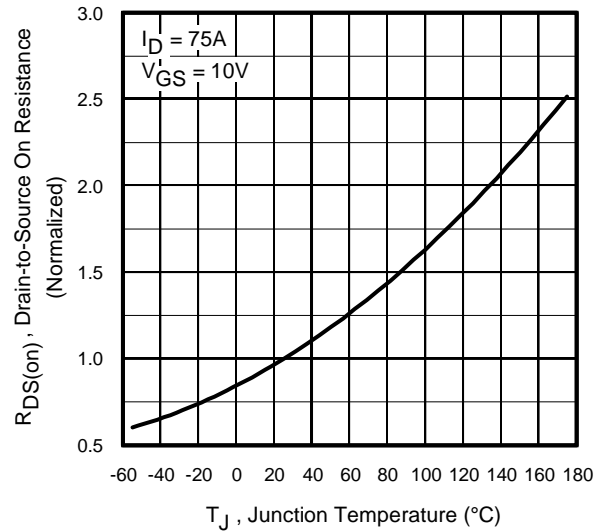

Fig 4. Normalized On-Resistance vs. Temperature

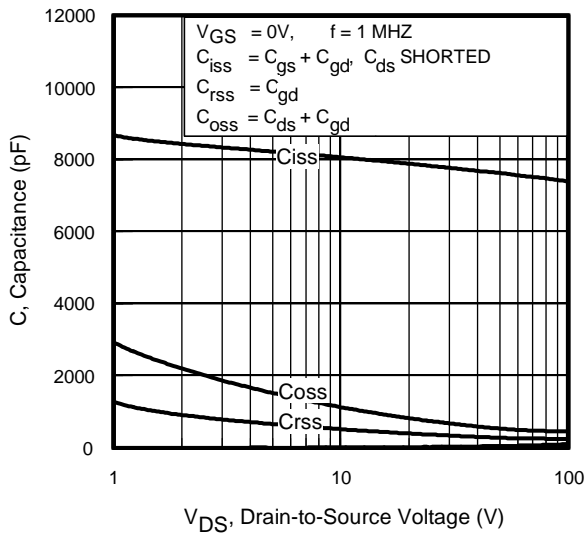

Fig 5. Typical Capacitance vs. Drain-to-Source Voltage

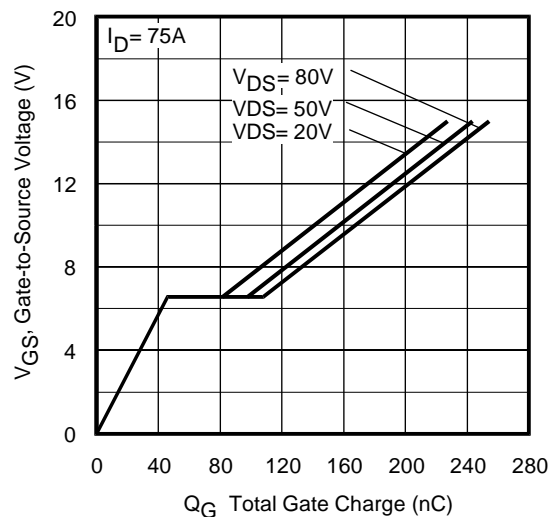
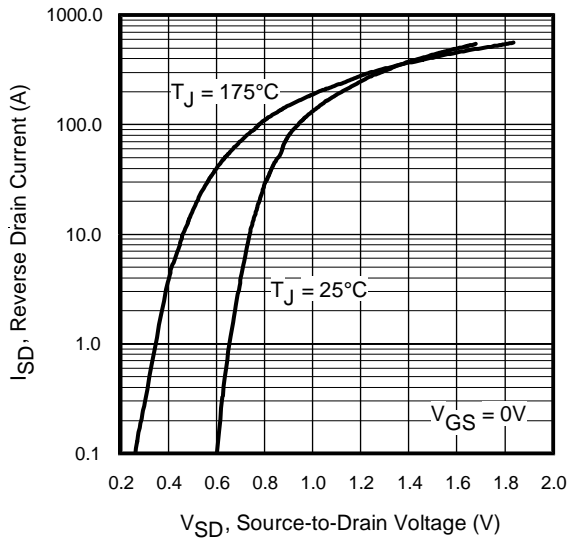
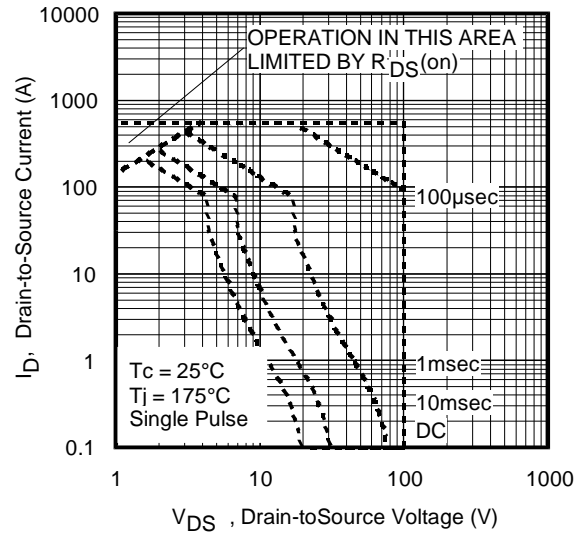

Fig 6. Typical Gate Charge vs. Gate-to-Source Voltage



**Fig 7.** Typical Source-Drain Diode Forward Voltage



**Fig 8.** Maximum Safe Operating Area

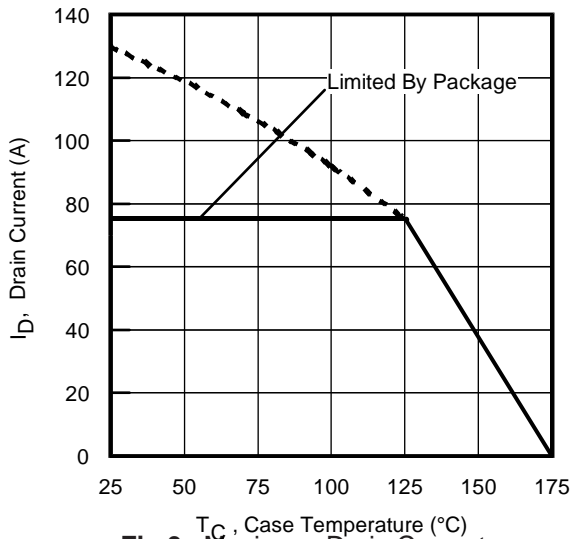

**Fig 9.** Maximum Drain Current vs. Case Temperature

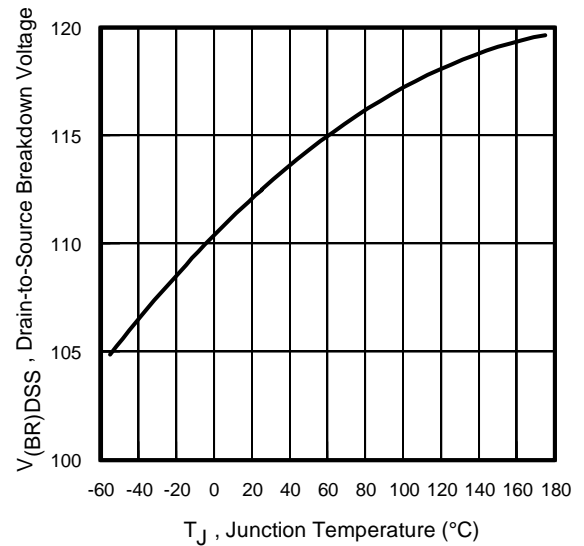

**Fig 10.** Drain-to-Source Breakdown Voltage

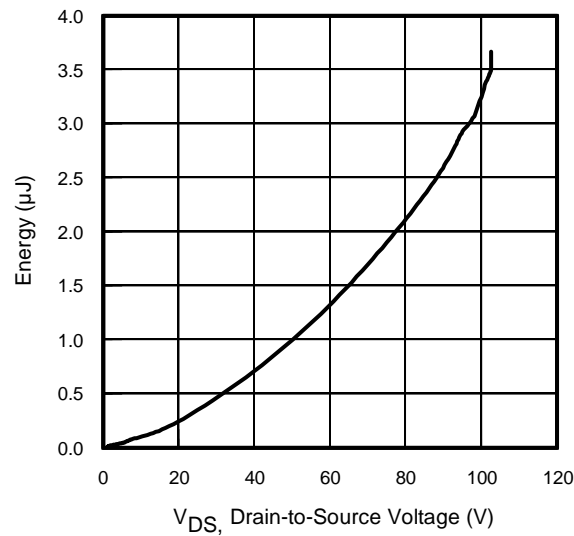

**Fig 11.** Typical  $C_{OSS}$  Stored Energy

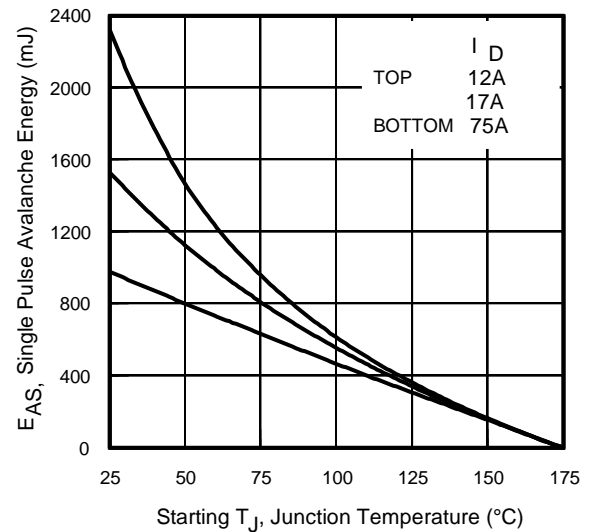

**Fig 12.** Maximum Avalanche Energy Vs. DrainCurrent

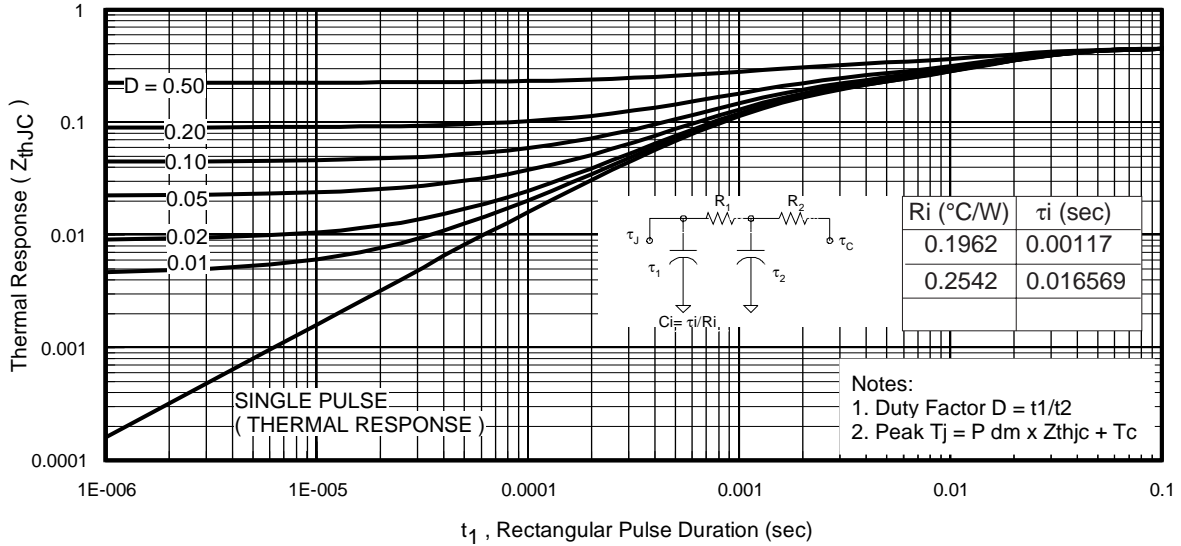

Fig 13. Maximum Effective Transient Thermal Impedance, Junction-to-Case

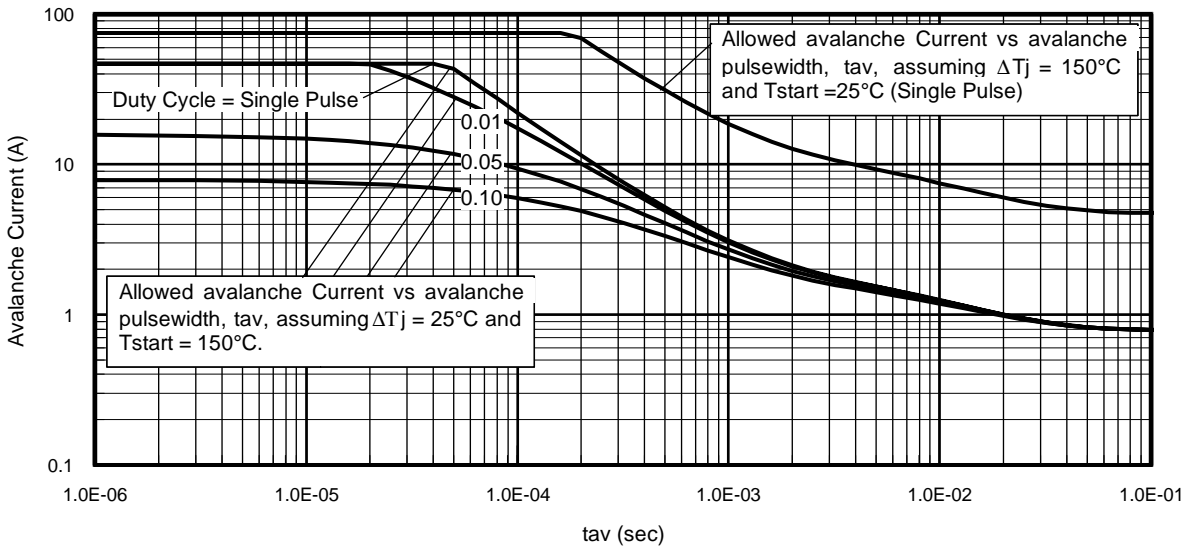

Fig 14. Typical Avalanche Current vs. Pulsewidth

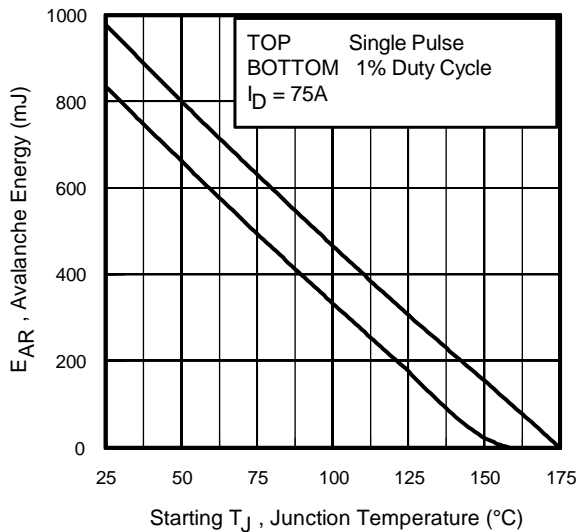

Fig 15. Maximum Avalanche Energy vs. Temperature

**Notes on Repetitive Avalanche Curves, Figures 14, 15:**  
(For further info, see AN-1005 at [www.irf.com](http://www.irf.com))

1. Avalanche failures assumption: Purely a thermal phenomenon and failure occurs at a temperature far in excess of  $T_{jmax}$ . This is validated for every part type.
2. Safe operation in Avalanche is allowed as long as neither  $T_{jmax}$  nor  $I_{av(max)}$  is exceeded.
3. Equation below based on circuit and waveforms shown in Figures 16a, 16b.
4.  $P_{D(ave)}$  = Average power dissipation per single avalanche pulse.
5.  $BV$  = Rated breakdown voltage (1.3 factor accounts for voltage increase during avalanche).
6.  $I_{av}$  = Allowable avalanche current.
7.  $\Delta T$  = Allowable rise in junction temperature, not to exceed  $T_{jmax}$  (assumed as  $25^{\circ}C$  in Figure 14, 15).  
 $t_{av}$  = Average time in avalanche.  
 $D$  = Duty cycle in avalanche =  $t_{av} \cdot f$   
 $Z_{thJC}(D, t_{av})$  = Transient thermal resistance, see Figures 13)

$$P_{D(ave)} = 1/2 (1.3 \cdot BV \cdot I_{av}) = \Delta T / Z_{thJC}$$

$$I_{av} = 2\Delta T / [1.3 \cdot BV \cdot Z_{th}]$$

$$E_{AS(AR)} = P_{D(ave)} \cdot t_{av}$$

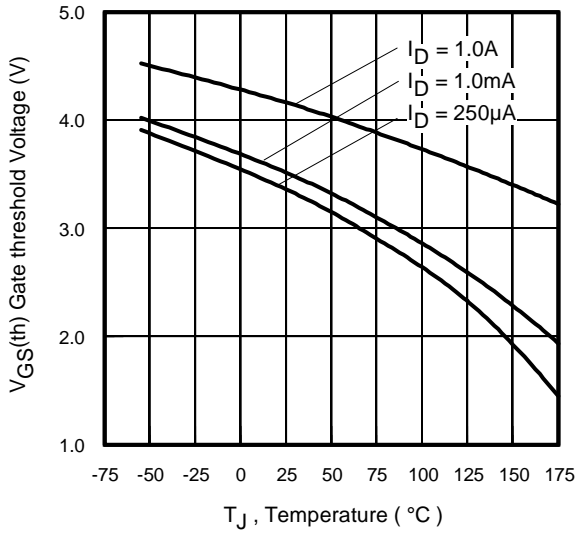

Fig 16. Threshold Voltage Vs. Temperature

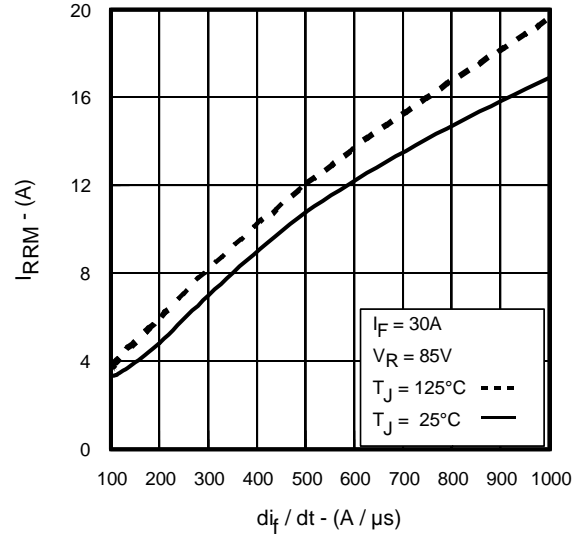

Fig. 17 - Typical Recovery Current vs.  $di_T/dt$

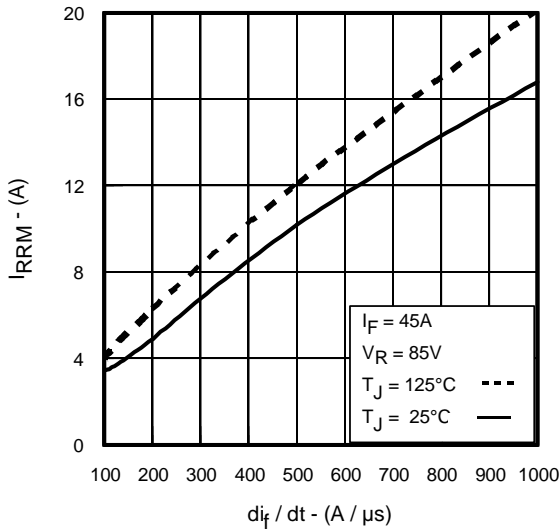

Fig. 18 - Typical Recovery Current vs.  $di_T/dt$

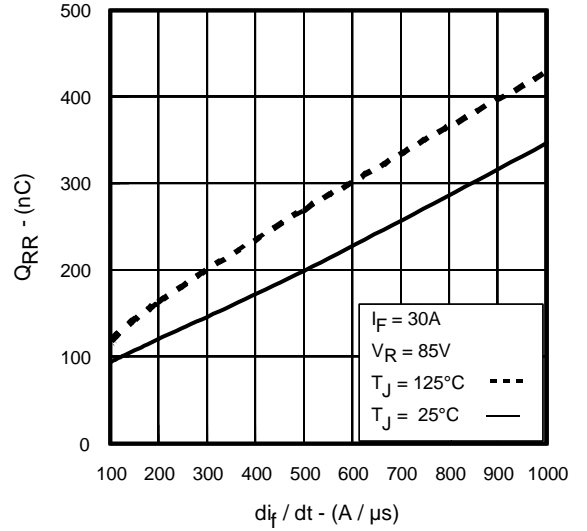

Fig. 19 - Typical Stored Charge vs.  $di_T/dt$

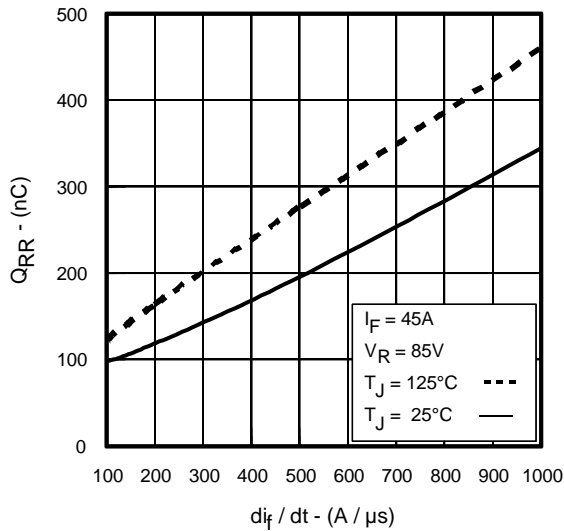
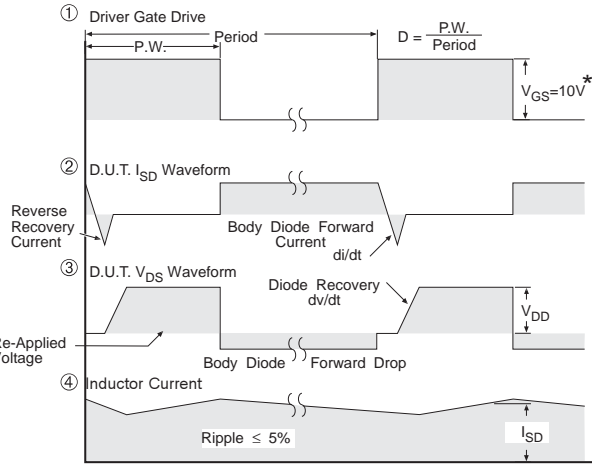
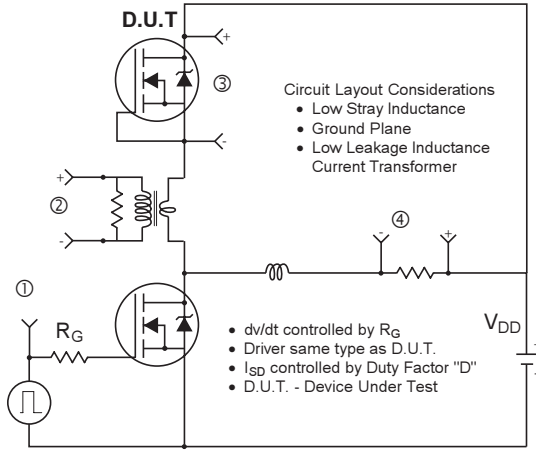
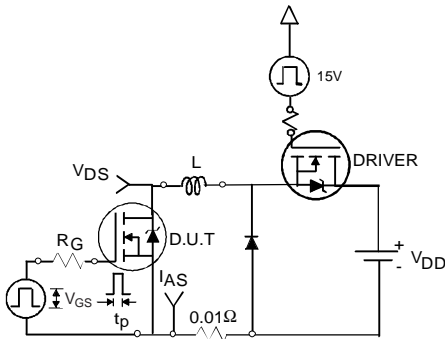

Fig. 20 - Typical Stored Charge vs.  $di_T/dt$



\*  $V_{GS} = 5V$  for Logic Level Devices

**Fig 21. Peak Diode Recovery dv/dt Test Circuit for N-Channel HEXFET® Power MOSFETs**



**Fig 22a. Unclamped Inductive Test Circuit**

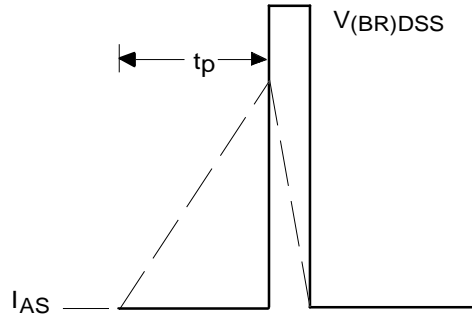

**Fig 22b. Unclamped Inductive Waveforms**

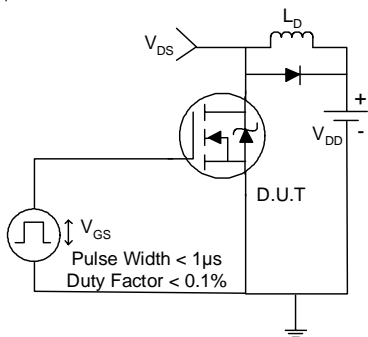

**Fig 23a. Switching Time Test Circuit**

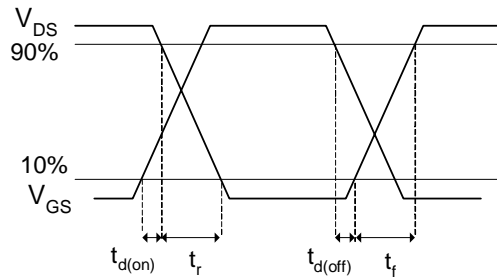

**Fig 23b. Switching Time Waveforms**

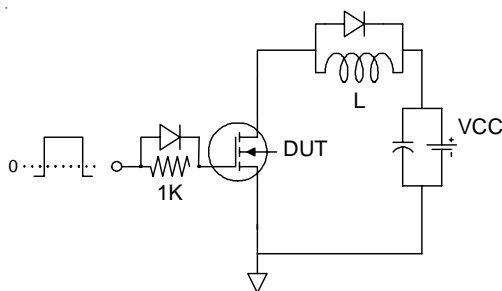

**Fig 24a. Gate Charge Test Circuit**

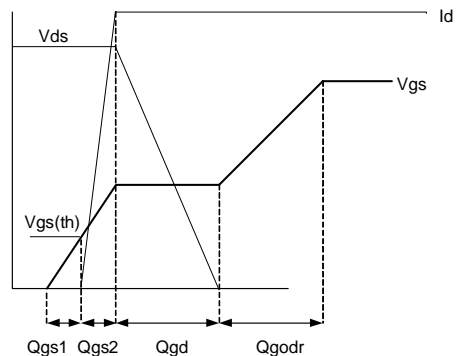

**Fig 24b. Gate Charge Waveform**

## TO-220AB Package Outline

Dimensions are shown in millimeters (inches)

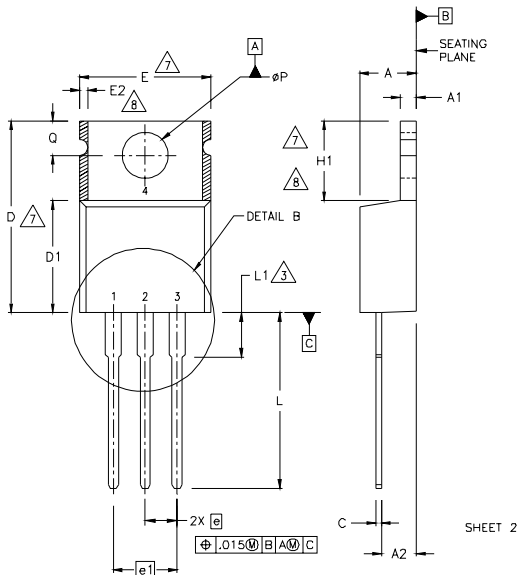

- NOTES:
- 1 DIMENSIONING AND TOLERANCING PER ASME Y14.5 M- 1994.
  - 2 DIMENSIONS ARE SHOWN IN INCHES [MILLIMETERS].
  - 3 LEAD DIMENSION AND FINISH UNCONTROLLED IN L1.
  - 4 DIMENSION D & E DO NOT INCLUDE MOLD FLASH. MOLD FLASH SHALL NOT EXCEED .005" (0.127) PER SIDE. THESE DIMENSIONS ARE MEASURED AT THE OUTERMOST EXTREMES OF THE PLASTIC BODY.
  - 5 DIMENSION b1 & c1 APPLY TO BASE METAL ONLY.
  - 6 CONTROLLING DIMENSION : INCHES.
  - 7 THERMAL PAD CONTOUR OPTIONAL WITHIN DIMENSIONS E,H1,D2 & E1
  - 8 DIMENSION E2 X H1 DEFINE A ZONE WHERE STAMPING AND SINGULATION IRREGULARITIES ARE ALLOWED.

**LEAD ASSIGNMENTS**

**HEXFEET**

- 1.- GATE
- 2.- DRAIN
- 3.- SOURCE

**IGBTs, CoPACK**

- 1.- GATE
- 2.- COLLECTOR
- 3.- EMITTER

**DIODES**

- 1.- ANODE/OPEN
- 2.- CATHODE
- 3.- ANODE

| SYMBOL | DIMENSIONS  |       |          |      | NOTES |
|--------|-------------|-------|----------|------|-------|
|        | MILLIMETERS |       | INCHES   |      |       |
|        | MIN.        | MAX.  | MIN.     | MAX. |       |
| A      | 3.56        | 4.82  | .140     | .190 |       |
| A1     | 0.51        | 1.40  | .020     | .055 |       |
| A2     | 2.04        | 2.92  | .080     | .115 |       |
| b      | 0.38        | 1.01  | .015     | .040 |       |
| b1     | 0.38        | 0.96  | .015     | .038 | 5     |
| b2     | 1.15        | 1.77  | .045     | .070 |       |
| b3     | 1.15        | 1.73  | .045     | .068 |       |
| c      | 0.36        | 0.61  | .014     | .024 |       |
| c1     | 0.36        | 0.56  | .014     | .022 | 5     |
| D      | 14.22       | 16.51 | .560     | .650 | 4     |
| D1     | 8.38        | 9.02  | .330     | .355 |       |
| D2     | 12.19       | 12.88 | .480     | .507 | 7     |
| E      | 9.66        | 10.66 | .380     | .420 | 4,7   |
| E1     | 8.38        | 8.89  | .330     | .350 | 7     |
| e      | 2.54 BSC    |       | .100 BSC |      |       |
| e1     | 5.08        |       | .200 BSC |      |       |
| H1     | 5.85        | 6.55  | .230     | .270 | 7,8   |
| L      | 12.70       | 14.73 | .500     | .580 |       |
| L1     | -           | 6.35  | -        | .250 | 3     |
| φP     | 3.54        | 4.08  | .139     | .161 |       |
| Q      | 2.54        | 3.42  | .100     | .135 |       |
| φ      | 90°-93°     |       | 90°-93°  |      |       |

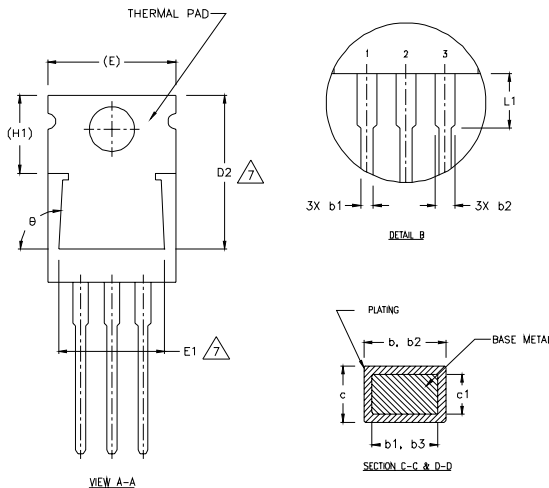

## TO-220AB Part Marking Information

EXAMPLE: THIS IS AN IRF1010  
 LOT CODE 1789  
 ASSEMBLED ON WW 19, 2000  
 IN THE ASSEMBLY LINE "C"

Note: "P" in assembly line position indicates "Lead - Free"

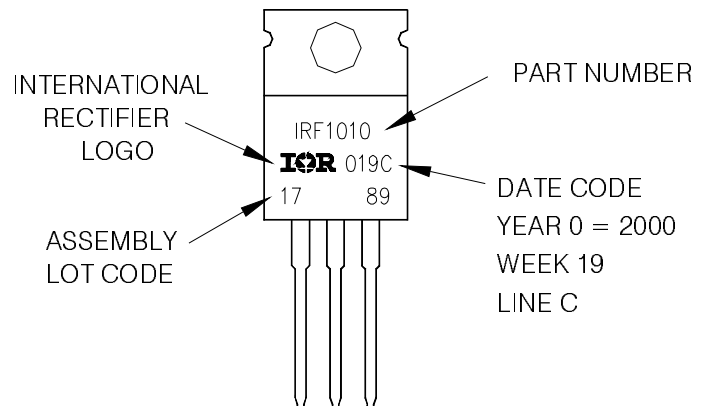

TO-220AB packages are not recommended for Surface Mount Application.

### TO-262 Package Outline

Dimensions are shown in millimeters (inches)

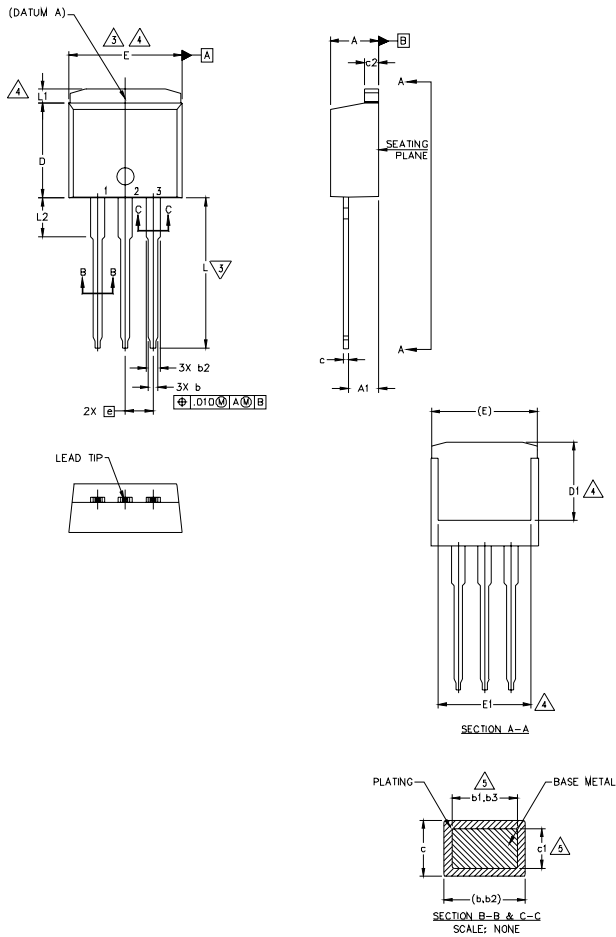

NOTES:

1. DIMENSIONING AND TOLERANCING PER ASME Y14.5M-1994
2. DIMENSIONS ARE SHOWN IN MILLIMETERS [INCHES].
3. DIMENSION D & E DO NOT INCLUDE MOLD FLASH. MOLD FLASH SHALL NOT EXCEED 0.127 [0.005"] PER SIDE. THESE DIMENSIONS ARE MEASURED AT THE OUTMOST EXTREMES OF THE PLASTIC BODY.
4. THERMAL PAD CONTOUR OPTIONAL WITHIN DIMENSION E, L1, D1 & E1.
5. DIMENSION b1 AND c1 APPLY TO BASE METAL ONLY.
6. CONTROLLING DIMENSION: INCH.
7. OUTLINE CONFORM TO JEDEC TO-262 EXCEPT A1(max.), b(min.) AND D1(min.) WHERE DIMENSIONS DERIVED THE ACTUAL PACKAGE OUTLINE.

| SYMBOL | DIMENSIONS  |       |        |      | NOTES |
|--------|-------------|-------|--------|------|-------|
|        | MILLIMETERS |       | INCHES |      |       |
|        | MIN.        | MAX.  | MIN.   | MAX. |       |
| A      | 4.06        | 4.83  | .160   | .190 |       |
| A1     | 2.03        | 3.02  | .080   | .119 |       |
| b      | 0.51        | 0.99  | .020   | .039 |       |
| b1     | 0.51        | 0.89  | .020   | .035 | 5     |
| b2     | 1.14        | 1.78  | .045   | .070 |       |
| b3     | 1.14        | 1.73  | .045   | .068 | 5     |
| c      | 0.38        | 0.74  | .015   | .029 |       |
| c1     | 0.38        | 0.58  | .015   | .023 | 5     |
| c2     | 1.14        | 1.65  | .045   | .065 |       |
| D      | 8.38        | 9.65  | .330   | .380 | 3     |
| D1     | 6.86        | -     | .270   | -    | 4     |
| E      | 9.65        | 10.67 | .380   | .420 | 3,4   |
| E1     | 6.22        | -     | .245   | -    | 4     |
| e      | 2.54        | BSC   | .100   | BSC  |       |
| L      | 13.46       | 14.10 | .530   | .555 |       |
| L1     | -           | 1.65  | -      | .065 |       |
| L2     | 3.56        | 3.71  | .140   | .146 |       |

LEAD ASSIGNMENTS

HEXFET

- 1.- GATE
- 2.- DRAIN
- 3.- SOURCE
- 4.- DRAIN

IGBTs, CoPACK

- 1.- GATE
- 2.- COLLECTOR
- 3.- EMITTER
- 4.- COLLECTOR

### TO-262 Part Marking Information

EXAMPLE: THIS IS AN IRL3103L  
LOT CODE 1789  
ASSEMBLED ON WW 19, 1997  
IN THE ASSEMBLY LINE "C"

Note: "P" in assembly line position indicates "Lead - Free"

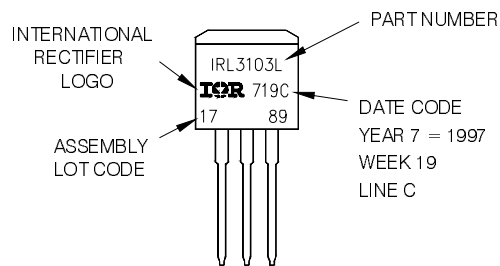

OR

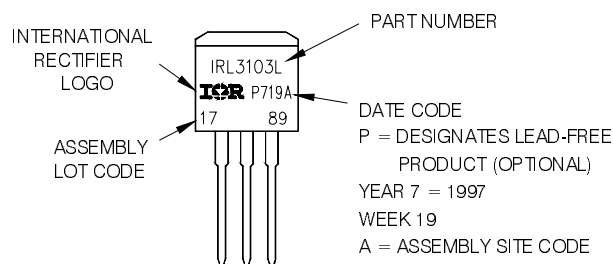

D<sup>2</sup>Pak (TO-263AB) Package Outline

Dimensions are shown in millimeters (inches)

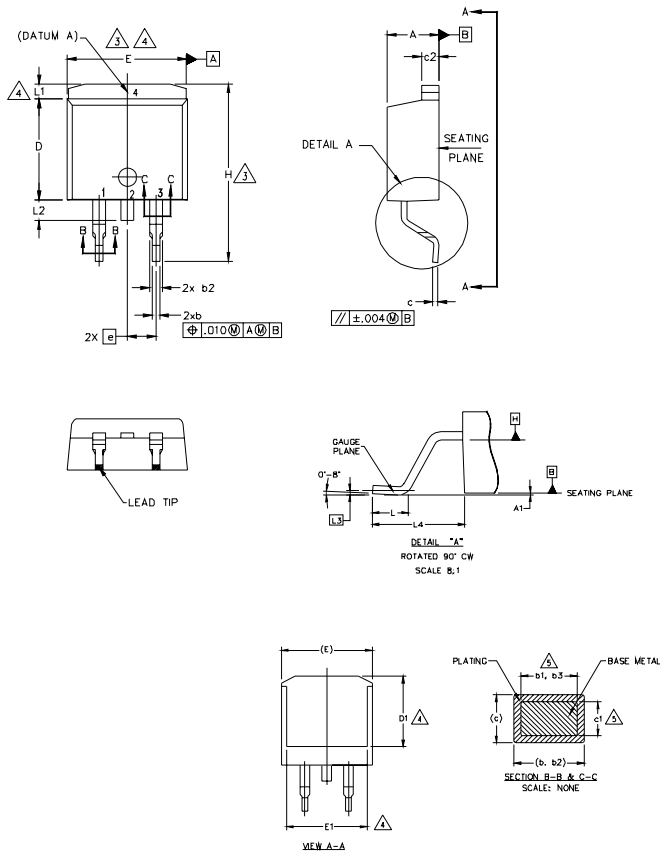

- NOTES:
1. DIMENSIONING AND TOLERANCING PER ASME Y14.5M-1994
  2. DIMENSIONS ARE SHOWN IN MILLIMETERS [INCHES].
  3. DIMENSION D & E DO NOT INCLUDE MOLD FLASH. MOLD FLASH SHALL NOT EXCEED 0.127 [.005"] PER SIDE. THESE DIMENSIONS ARE MEASURED AT THE OUTMOST EXTREMES OF THE PLASTIC BODY AT DATUM H.
  4. THERMAL PAD CONTOUR OPTIONAL WITHIN DIMENSION E, L1, D1 & E1.
  5. DIMENSION b1 AND c1 APPLY TO BASE METAL ONLY.
  6. DATUM A & B TO BE DETERMINED AT DATUM PLANE H.
  7. CONTROLLING DIMENSION: INCH.
  8. OUTLINE CONFORMS TO JEDEC OUTLINE TO-263AB.

| SYMBOL | DIMENSIONS  |       |          |      | NOTES |
|--------|-------------|-------|----------|------|-------|
|        | MILLIMETERS |       | INCHES   |      |       |
|        | MIN.        | MAX.  | MIN.     | MAX. |       |
| A      | 4.06        | 4.83  | .160     | .190 |       |
| A1     | 0.00        | 0.254 | .000     | .010 |       |
| b      | 0.51        | 0.99  | .020     | .039 |       |
| b1     | 0.51        | 0.89  | .020     | .035 | 5     |
| b2     | 1.14        | 1.78  | .045     | .070 |       |
| b3     | 1.14        | 1.73  | .045     | .068 | 5     |
| c      | 0.38        | 0.74  | .015     | .029 |       |
| c1     | 0.38        | 0.58  | .015     | .023 | 5     |
| c2     | 1.14        | 1.65  | .045     | .065 |       |
| D      | 8.38        | 9.65  | .330     | .380 |       |
| D1     | 6.86        | -     | .270     | -    | 4     |
| E      | 9.65        | 10.67 | .380     | .420 | 3,4   |
| E1     | 6.22        | -     | .245     | -    | 4     |
| e      | 2.54 BSC    |       | .100 BSC |      |       |
| H      | 14.61       | 15.88 | .575     | .625 |       |
| L      | 1.78        | 2.79  | .070     | .110 |       |
| L1     | -           | 1.65  | -        | .066 | 4     |
| L2     | 1.27        | 1.78  | -        | .070 |       |
| L3     | 0.25 BSC    |       | .010 BSC |      |       |
| L4     | 4.78        | 5.28  | .188     | .208 |       |

LEAD ASSIGNMENTS

HEXFET

- 1.- GATE
- 2, 4.- DRAIN
- 3.- SOURCE

IGBTs, CoPACK

- 1.- GATE
- 2, 4.- COLLECTOR
- 3.- EMITTER

DIODES

- 1.- ANODE \*
- 2, 4.- CATHODE
- 3.- ANODE

\* PART DEPENDENT.

D<sup>2</sup>Pak (TO-263AB) Part Marking Information

EXAMPLE: THIS IS AN IRF530S WITH  
LOT CODE 8024  
ASSEMBLED ON WW 02, 2000  
IN THE ASSEMBLY LINE "L"

Note: "P" in assembly line position  
indicates "Lead - Free"

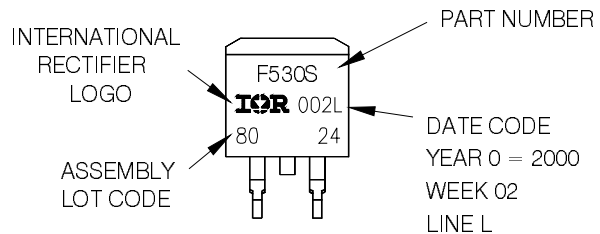

OR

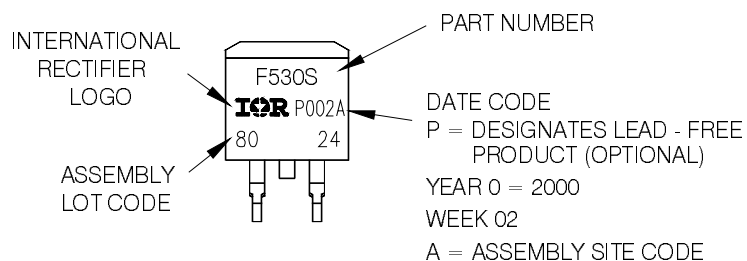

D<sup>2</sup>Pak (TO-263AB) Tape & Reel Information

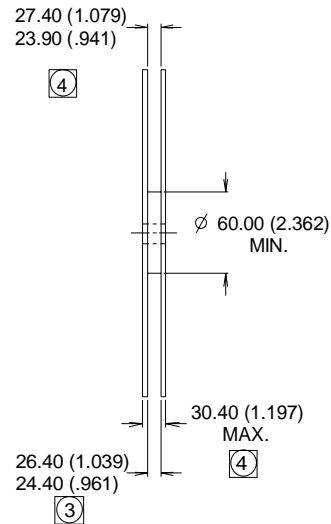
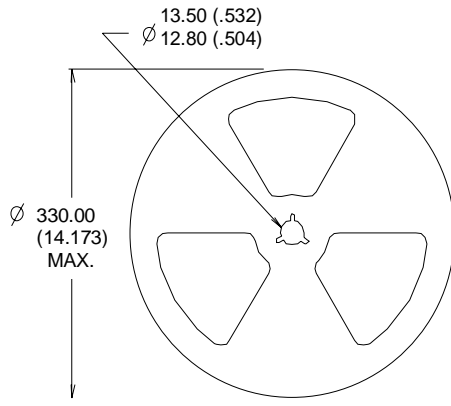
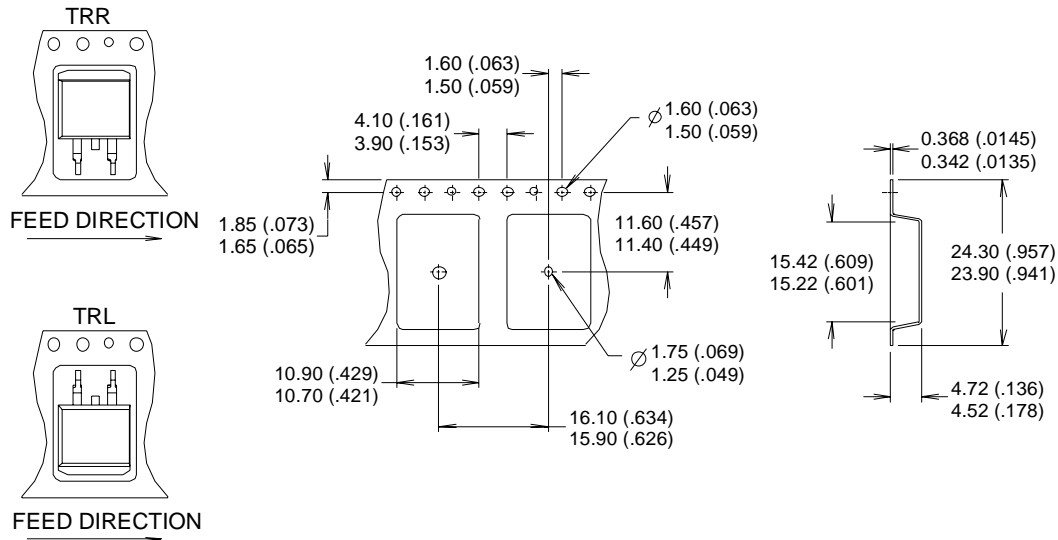

- NOTES :
1. CONFORMS TO EIA-418.
  2. CONTROLLING DIMENSION: MILLIMETER.
  3. DIMENSION MEASURED @ HUB.
  4. INCLUDES FLANGE DISTORTION @ OUTER EDGE.

Data and specifications subject to change without notice.  
 This product has been designed and qualified for the Industrial market.  
 Qualification Standards can be found on IR's Web site.

Note: For the most current drawings please refer to the IR website at:  
<http://www.irf.com/package/>

## Looking for pricing, stock, or lifecycle information?

Click below to explore more details on WIN SOURCE:

 [View IRFS4310TRRPBF on WIN SOURCE](#)

 [Infineon Technologies](#) Information

## Optimize Your Supply Chain with WIN SOURCE Solutions

-  Global Sourcing Solution
-  Obsolete Management
-  Cost Control Management
-  Shortage Management
-  Alternative Solution
-  Excess Inventory Management