

IRU1010-18 & (PbF)

1A LOW DROPOUT POSITIVE FIXED 1.8V REGULATOR

FEATURES

- Guaranteed < 1.3V Dropout at Full Load Current
- Fast Transient Response
- 1% Voltage Reference Initial Accuracy
- Built-In Thermal Shutdown
- Available in SOT-223, D-Pak, Ultra Thin-Pak™ and 8-Pin SOIC Surface-Mount Packages

APPLICATIONS

- Low Voltage IC Supply Applications
- DSP Core Voltage
- 8-Lead SOIC (IRU1010-18CS) is also available
LEAD-FREE

DESCRIPTION

The IRU1010-18 is a low dropout three-terminal fixed output regulator with minimum of 1A output current capability. This product is specifically designed to provide well regulated supply for low voltage IC applications as well as generating clock supply for PC applications. The IRU1010-18 is guaranteed to have <1.3V dropout at full load current making it ideal to provide well regulated with 3.8V input supply. The IRU1010-18 is specifically designed to be stable with low cost aluminum capacitors while maintaining stability with low ESR tantalum caps.

TYPICAL APPLICATION

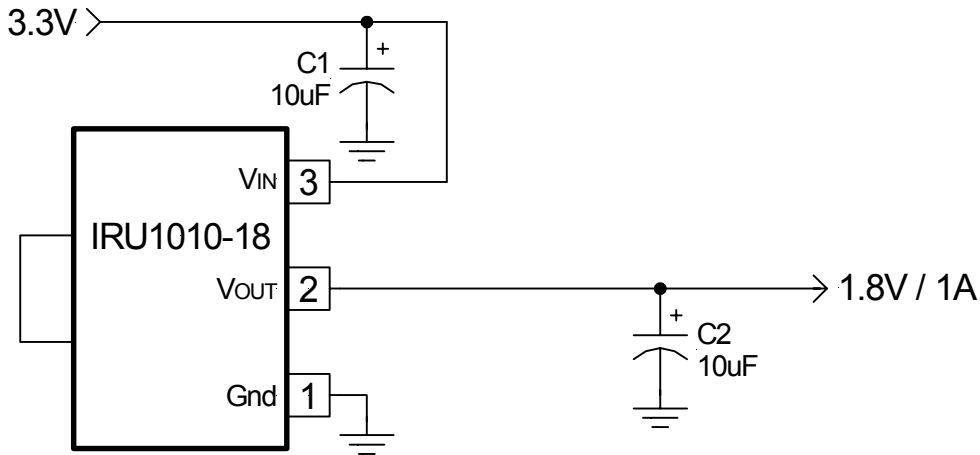

Figure 1 - Typical set-up of the IRU1010-18 in a 3.3V to 1.8V regulator application.

PACKAGE ORDER INFORMATION

Basic Part (Non-Lead Free)

T _J (°C)	2-PIN PLASTIC TO-252 (D-Pak)	2-PIN PLASTIC Ultra Thin-Pak™ (P)	8-PIN PLASTIC SOIC (S)	3-PIN PLASTIC SOT-223 (Y)
0 To 125	IRU1010-18CD	IRU1010-18CP	IRU1010-18CS	IRU1010-18CY
Leadfree Part				
T _J (°C)	2-PIN PLASTIC TO-252 (D-Pak)	2-PIN PLASTIC Ultra Thin-Pak™ (P)	8-PIN PLASTIC SOIC (S)	3-PIN PLASTIC SOT-223 (Y)
0 To 125	Not available	Not available	IRU1010-18CSPbF	Not available

ABSOLUTE MAXIMUM RATINGS

Input Voltage (V_{IN})	7V
Power Dissipation	Internally Limited
Storage Temperature Range	-65°C To 150°C
Operating Junction Temperature Range	0°C To 125°C

PACKAGE INFORMATION

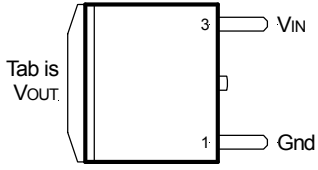
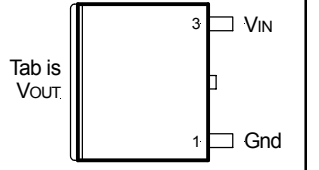
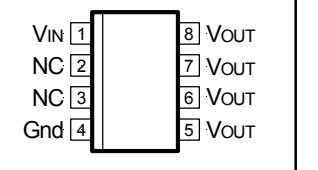
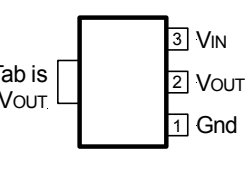
2-PIN PLASTIC TO-252 (D-Pak)	2-PIN ULTRA THIN-PAK™ (P)	8-PIN PLASTIC SOIC (S)	3-PIN PLASTIC SOT-223 (Y)
 <p>Tab is VOUT.</p> <p>$\theta_{JA}=70^{\circ}\text{C/W}$ for 0.5" Sq pad</p>	 <p>Tab is VOUT.</p> <p>$\theta_{JA}=70^{\circ}\text{C/W}$ for 0.5" Sq pad</p>	 <p>$\theta_{JA}=55^{\circ}\text{C/W}$ for 1" Sq pad</p>	 <p>Tab is VOUT.</p> <p>$\theta_{JA}=90^{\circ}\text{C/W}$ for 0.4" Sq pad</p>

ELECTRICAL SPECIFICATIONS

Unless otherwise specified, these specifications apply over $C_{IN}=1\mu\text{F}$, $V_{IN}=5\text{V}$, $C_{OUT}=10\mu\text{F}$ and $T_J=0$ to 125°C . Typical values refer to $T_J=25^{\circ}\text{C}$.

PARAMETER	SYM	TEST CONDITION	MIN	TYP	MAX	UNITS
Output Voltage	V_o	$I_o=10\text{mA}$, $T_J=25^{\circ}\text{C}$ $I_o=10\text{mA}$	1.782 1.764	1.800 1.800	1.818 1.836	V
Line Regulation		$I_o=10\text{mA}$, $4.75\text{V}<V_{IN}<7\text{V}$			7	mV
Load Regulation (Note 1)		$10\text{mA}<I_o<1\text{A}$			17	mV
Dropout Voltage (Note 2)		$I_o=1\text{A}$			1.3	V
Current Limit		$\Delta V_o=100\text{mV}$	1.1			A
Thermal Regulation		30ms Pulse, $I_o=1\text{A}$		0.01		%/W
Ripple Rejection		$f=120\text{Hz}$, $C_o=25\mu\text{F}$ Tantalum, $I_o=0.5\text{A}$		70		dB
Temperature Stability		$I_o=10\text{mA}$		0.5		%
Long Term Stability		$T_J=125^{\circ}\text{C}$, 1000Hrs		0.3		%
RMS Output Noise		$T_J=25^{\circ}\text{C}$, $10\text{Hz}<f<10\text{KHz}$		0.003		% V_o

Note 1: Low duty cycle pulse testing with Kelvin connections is required in order to maintain accurate data.

Note 2: Dropout voltage is defined as the minimum differential voltage between V_{IN} and V_{OUT} required to maintain regulation at V_{OUT} . It is measured when the output voltage drops 1% below its nominal value.

PIN DESCRIPTIONS

PIN#	PIN SYMBOL	PIN DESCRIPTION
1	Gnd	Ground pin. This pin must be connected to ground plane using a low inductance short connection.
2	V _{OUT}	The output of the regulator. This pin is also connected to the tab of the package. An output capacitor must be connected to this pin to insure stability of the regulator.
3	V _{IN}	Input pin of the regulator. Typically a large storage capacitor is connected from this pin to ground to insure that the input voltage does not sag below the minimum dropout voltage during the load transient response. This pin must always be 1.3V higher than V _{OUT} in order for the device to regulate properly.

BLOCK DIAGRAM

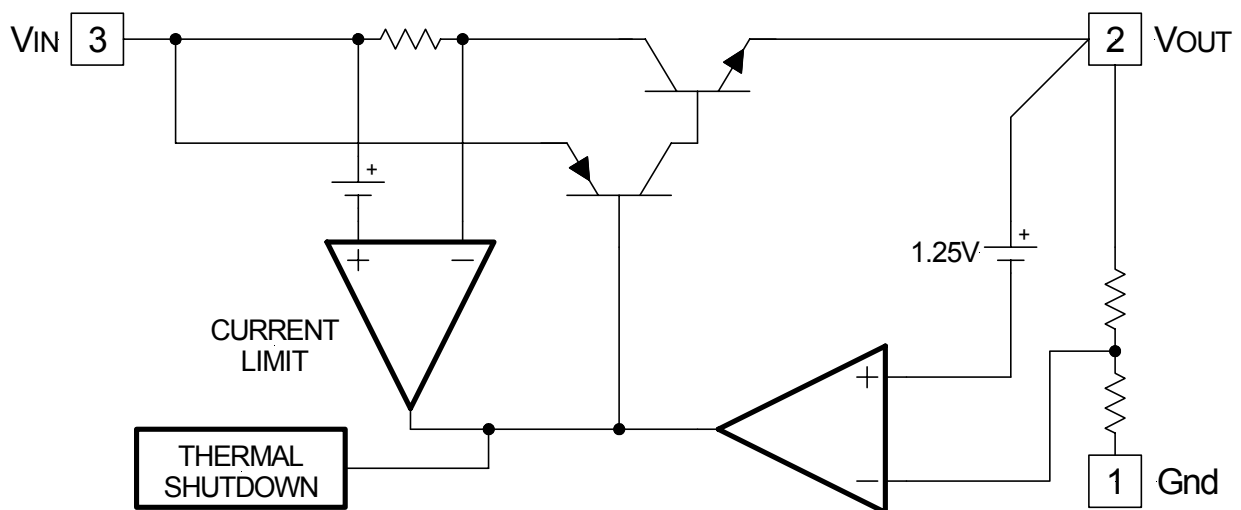
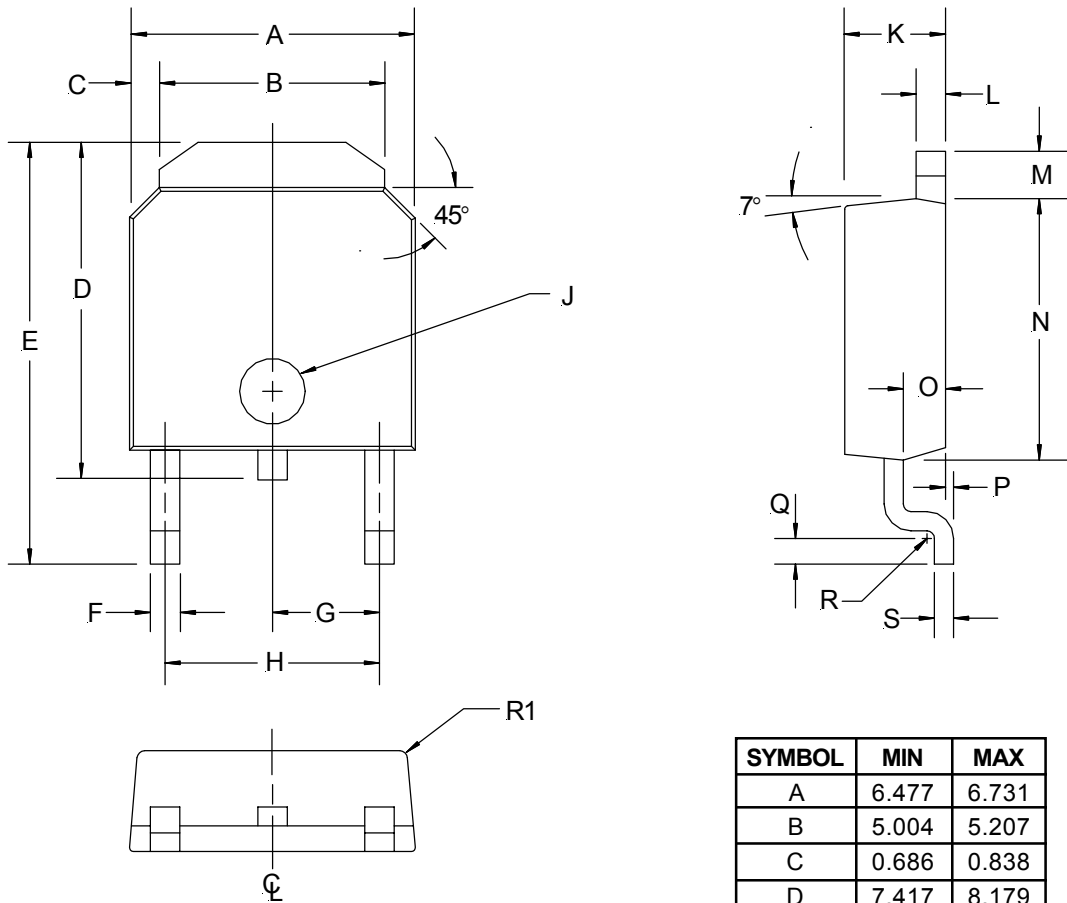

Figure 2 - Simplified block diagram of the IRU1010-18.

(D) TO-252 Package
2-Pin



SYMBOL	MIN	MAX
A	6.477	6.731
B	5.004	5.207
C	0.686	0.838
D	7.417	8.179
E	9.703	10.084
F	0.635	0.889
G	2.286 BSC	
H	4.521	4.623
J	Ø1.52	Ø1.62
K	2.184	2.388
L	0.762	0.864
M	1.016	1.118
N	5.969	6.223
O	1.016	1.118
P	0	0.102
Q	0.534	0.686
R	R0.31 TYP	
R1	R0.51 TYP	
S	0.428	0.588

NOTE: ALL MEASUREMENTS
ARE IN MILLIMETERS.

**(P) Ultra Thin-Pak™
 2-Pin**

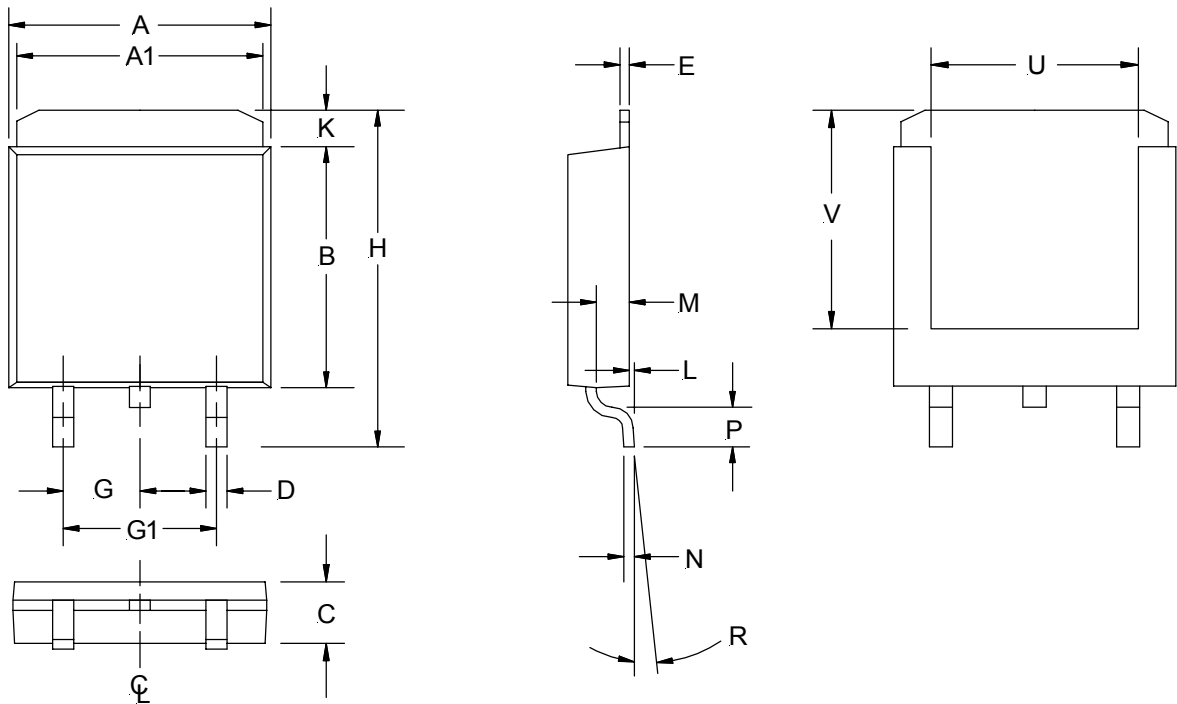

SYMBOL	MIN	MAX
A	5.91	6.17
A1	5.54	5.79
B	6.02	6.27
C	1.70	2.03
D	0.63	0.79
E	0.17	0.33
G	2.16	2.41
G1	4.45	4.70
H	9.42	9.68
K	0.76	1.27
L	0.02	0.13
M	0.89	1.14
N	0.25	0.25
P	0.94	1.19
R	2°	6°
U	2.92	3.30
V	5.08 NOM	

NOTE: ALL MEASUREMENTS
 ARE IN MILLIMETERS.

(S) SOIC Package
8-Pin Surface Mount, Narrow Body

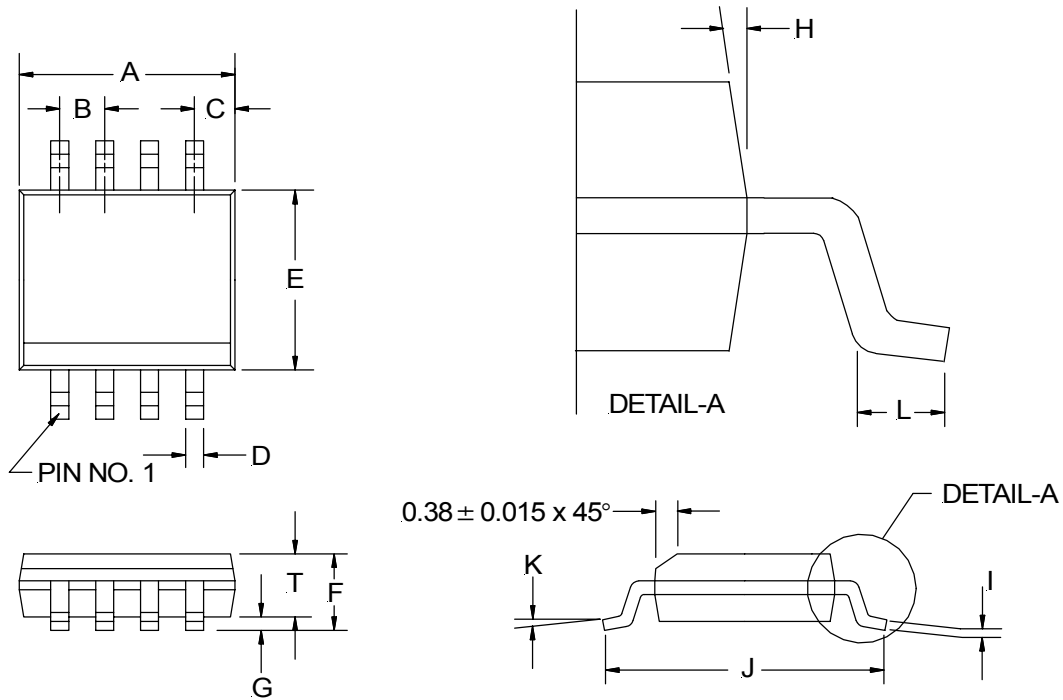

8-PIN		
SYMBOL	MIN	MAX
A	4.80	4.98
B	1.27 BSC	
C	0.53 REF	
D	0.36	0.46
E	3.81	3.99
F	1.52	1.72
G	0.10	0.25
H	7° BSC	
I	0.19	0.25
J	5.80	6.20
K	0°	8°
L	0.41	1.27
T	1.37	1.57

NOTE: ALL MEASUREMENTS
ARE IN MILLIMETERS.

**(Y) SOT-223 Package
 3-Pin**

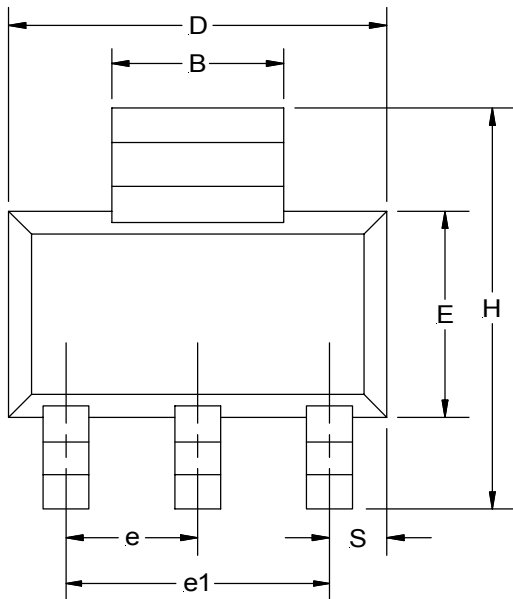

SYMBOL	MIN	MAX
A	1.498	1.702
A1	0.02	0.11
B	2.895	3.15
B1	0.637	0.85
C	0.239	0.381
D	6.299	6.706
E	3.30	3.708
e	2.209	2.953
e1	4.496	4.699
H	6.70	7.30
Q	0°	10°
Q1	7°	16°
Q2	7°	16°
S	0.838	1.05
T	1.092	1.30

NOTE: ALL MEASUREMENTS
 ARE IN MILLIMETERS.

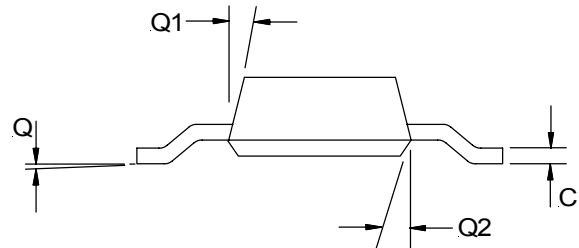
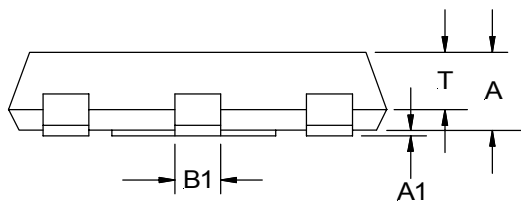

PACKAGE SHIPMENT METHOD

PKG DESIG	PACKAGE DESCRIPTION	PIN COUNT	PARTS PER TUBE	PARTS PER REEL	T & R Orientation
D	TO-252, (D-Pak)	2	75	2500	Fig A
P	Ultra Thin-Pak™	2	75	2500	Fig B
S	SOIC, Narrow Body	8	95	2500	Fig C
Y	SOT-223	3	80	2500	Fig D

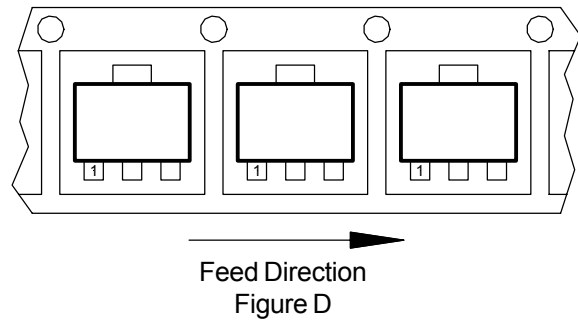
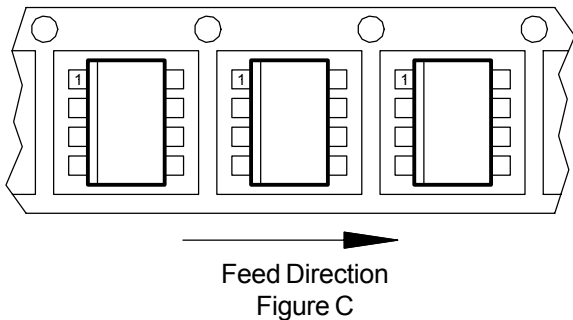
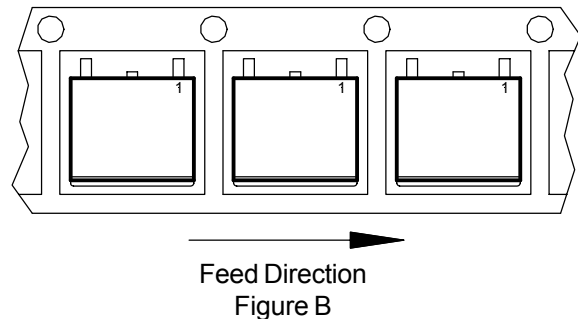
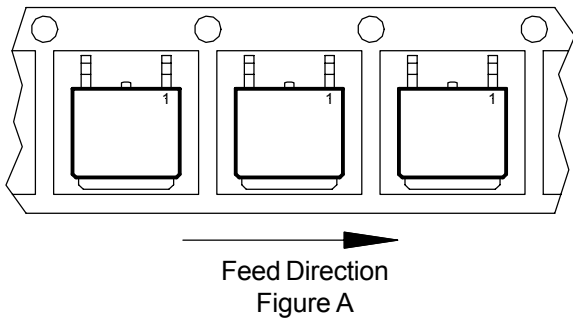

Looking for pricing, stock, or lifecycle information?

Click below to explore more details on WIN SOURCE:

 [View IRU1010-18CD](#) on WIN SOURCE

 [Infineon Technologies](#) Information

Optimize Your Supply Chain with WIN SOURCE Solutions

-  Global Sourcing Solution
-  Obsolete Management
-  Cost Control Management
-  Shortage Management
-  Alternative Solution
-  Excess Inventory Management