



**THE DATASHEET OF  
IS61LV25616AL-10TL-TR**



## 256K x 16 HIGH SPEED ASYNCHRONOUS CMOS STATIC RAM WITH 3.3V SUPPLY

DECEMBER 2011

### FEATURES

- High-speed access time:
  - 10, 12 ns
- CMOS low power operation
- Low stand-by power:
  - Less than 5 mA (typ.) CMOS stand-by
- TTL compatible interface levels
- Single 3.3V power supply
- Fully static operation: no clock or refresh required
- Three state outputs
- Data control for upper and lower bytes
- Industrial temperature available
- Lead-free available

### DESCRIPTION

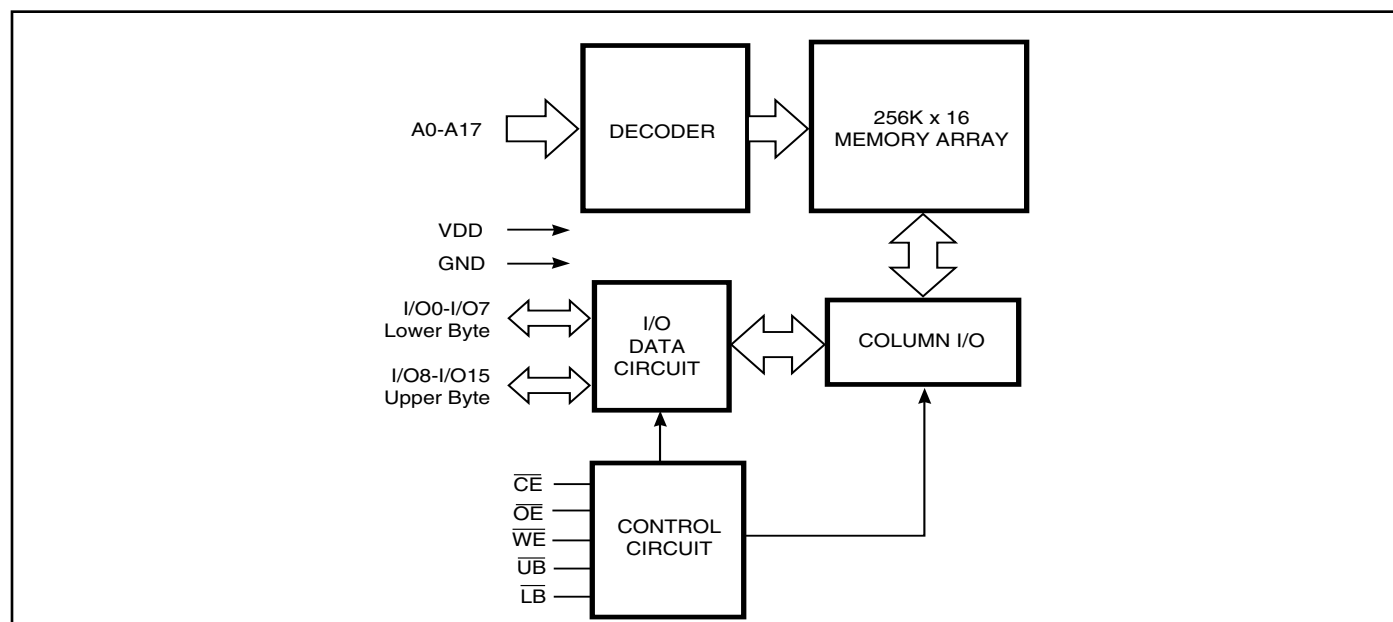
The *ISSI* IS61LV25616AL is a high-speed, 4,194,304-bit static RAM organized as 262,144 words by 16 bits. It is fabricated using *ISSI*'s high-performance CMOS technology. This highly reliable process coupled with innovative circuit design techniques, yields high-performance and low power consumption devices.

When  $\overline{CE}$  is HIGH (deselected), the device assumes a standby mode at which the power dissipation can be reduced down with CMOS input levels.

Easy memory expansion is provided by using Chip Enable and Output Enable inputs,  $\overline{CE}$  and  $\overline{OE}$ . The active LOW Write Enable ( $\overline{WE}$ ) controls both writing and reading of the memory. A data byte allows Upper Byte ( $\overline{UB}$ ) and Lower Byte ( $\overline{LB}$ ) access.

The IS61LV25616AL is packaged in the JEDEC standard 44-pin 400-mil SOJ, 44-pin TSOP Type II, 44-pin LQFP and 48-pin Mini BGA (8mm x 10mm).

### FUNCTIONAL BLOCK DIAGRAM



Copyright © 2011 Integrated Silicon Solution, Inc. All rights reserved. ISSI reserves the right to make changes to this specification and its products at any time without notice. ISSI assumes no liability arising out of the application or use of any information, products or services described herein. Customers are advised to obtain the latest version of this device specification before relying on any published information and before placing orders for products.

Integrated Silicon Solution, Inc. does not recommend the use of any of its products in life support applications where the failure or malfunction of the product can reasonably be expected to cause failure of the life support system or to significantly affect its safety or effectiveness. Products are not authorized for use in such applications unless Integrated Silicon Solution, Inc. receives written assurance to its satisfaction, that:

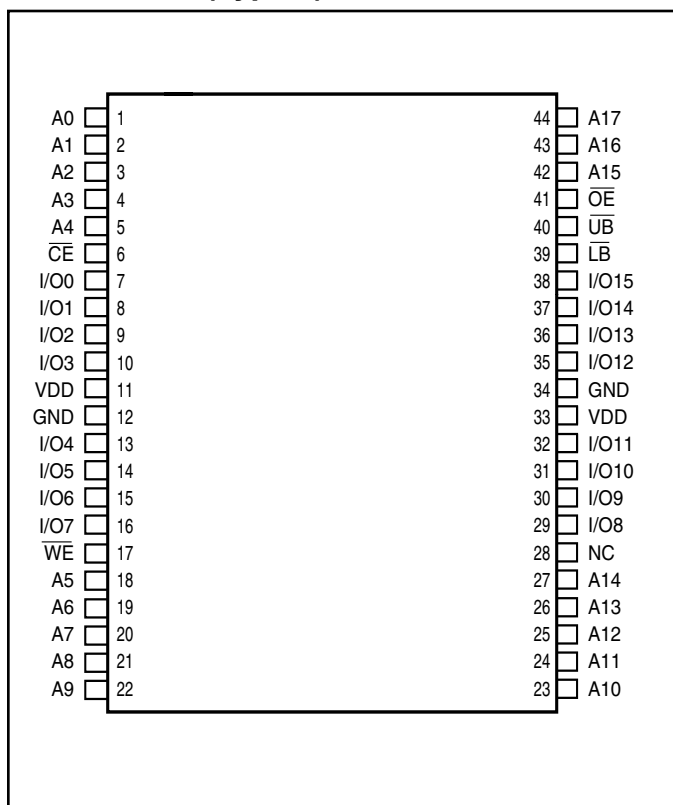
- a.) the risk of injury or damage has been minimized;
- b.) the user assume all such risks; and
- c.) potential liability of Integrated Silicon Solution, Inc is adequately protected under the circumstances

**TRUTH TABLE**

Mode	$\overline{WE}$	$\overline{CE}$	$\overline{OE}$	$\overline{LB}$	$\overline{UB}$	I/O PIN		V <sub>DD</sub> Current
						I/O0-I/O7	I/O8-I/O15	
Not Selected	X	H	X	X	X	High-Z	High-Z	I <sub>SB1</sub> , I <sub>SB2</sub>
Output Disabled	H	L	H	X	X	High-Z	High-Z	I <sub>CC</sub>
	X	L	X	H	H	High-Z	High-Z	
Read	H	L	L	L	H	DOUT	High-Z	I <sub>CC</sub>
	H	L	L	H	L	High-Z	DOUT	
	H	L	L	L	L	DOUT	DOUT	
Write	L	L	X	L	H	DIN	High-Z	I <sub>CC</sub>
	L	L	X	H	L	High-Z	DIN	
	L	L	X	L	L	DIN	DIN	

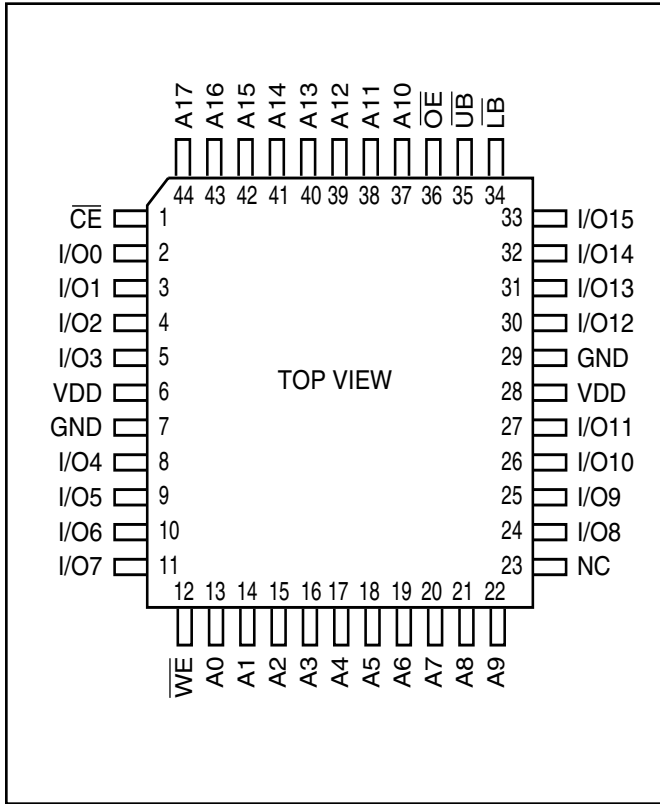
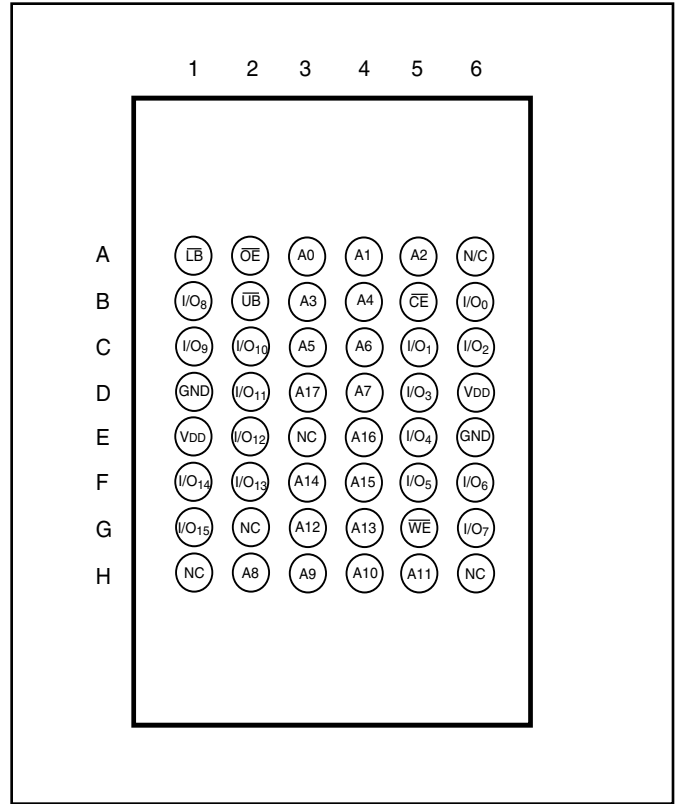
**PIN CONFIGURATIONS**

**44-Pin TSOP (Type II) and SOJ**



**PIN DESCRIPTIONS**

A0-A17	Address Inputs
I/O0-I/O15	Data Inputs/Outputs
$\overline{CE}$	Chip Enable Input
$\overline{OE}$	Output Enable Input
$\overline{WE}$	Write Enable Input
$\overline{LB}$	Lower-byte Control (I/O0-I/O7)
$\overline{UB}$	Upper-byte Control (I/O8-I/O15)
NC	No Connection
V <sub>DD</sub>	Power
GND	Ground

**PIN CONFIGURATIONS**
**44-Pin LQFP**

**48-Pin mini BGA**

**PIN DESCRIPTIONS**

A0-A17	Address Inputs
I/O0-I/O15	Data Inputs/Outputs
$\overline{CE}$	Chip Enable Input
OE	Output Enable Input
$\overline{WE}$	Write Enable Input
$\overline{LB}$	Lower-byte Control (I/O0-I/O7)
$\overline{UB}$	Upper-byte Control (I/O8-I/O15)
NC	No Connection
V <sub>DD</sub>	Power
GND	Ground

## ABSOLUTE MAXIMUM RATINGS<sup>(1)</sup>

Symbol	Parameter	Value	Unit
V <sub>TERM</sub>	Terminal Voltage with Respect to GND	-0.5 to V <sub>DD</sub> +0.5	V
T <sub>STG</sub>	Storage Temperature	-65 to +150	°C
P <sub>T</sub>	Power Dissipation	1.0	W

### Note:

1. Stress greater than those listed under ABSOLUTE MAXIMUM RATINGS may cause permanent damage to the device. This is a stress rating only and functional operation of the device at these or any other conditions above those indicated in the operational sections of this specification is not implied. Exposure to absolute maximum rating conditions for extended periods may affect reliability.

## OPERATING RANGE

Range	Ambient Temperature	V <sub>DD</sub>	
		10ns	12ns
Commercial	0°C to +70°C	3.3V +10%, -5%	3.3V ± 10%
Industrial	-40°C to +85°C	3.3V +10%, -5%	3.3V ± 10%

## DC ELECTRICAL CHARACTERISTICS (Over Operating Range)

Symbol	Parameter	Test Conditions	Min.	Max.	Unit
V <sub>OH</sub>	Output HIGH Voltage	V <sub>DD</sub> = Min., I <sub>OH</sub> = -4.0 mA	2.4	—	V
V <sub>OL</sub>	Output LOW Voltage	V <sub>DD</sub> = Min., I <sub>OL</sub> = 8.0 mA	—	0.4	V
V <sub>IH</sub>	Input HIGH Voltage		2.0	V <sub>DD</sub> + 0.3	V
V <sub>IL</sub>	Input LOW Voltage <sup>(1)</sup>		-0.3	0.8	V
I <sub>LI</sub>	Input Leakage	GND ≤ V <sub>IN</sub> ≤ V <sub>DD</sub>	Com. Ind.	-2 5	μA
I <sub>LO</sub>	Output Leakage	GND ≤ V <sub>OUT</sub> ≤ V <sub>DD</sub> Outputs Disabled	Com. Ind.	-2 5	μA

### Notes:

1. V<sub>IL</sub> (min.) = -2.0V for pulse width less than 10 ns.

**POWER SUPPLY CHARACTERISTICS<sup>(1)</sup>** (Over Operating Range)

Symbol	Parameter	Test Conditions	-10		-12		Unit	
			Min.	Max.	Min.	Max.		
I <sub>CC</sub>	V <sub>DD</sub> Dynamic Operating Supply Current	V <sub>DD</sub> = Max., I <sub>OUT</sub> = 0 mA, f = f <sub>MAX</sub>	Com.	—	100	—	90	mA
		Ind.	—	110	—	100		
I <sub>SB</sub>	TTL Standby Current (TTL Inputs)	V <sub>DD</sub> = Max., V <sub>IN</sub> = V <sub>IH</sub> or V <sub>IL</sub> CE ≥ V <sub>IH</sub> , f = f <sub>MAX</sub> .	Com.	—	50	—	45	mA
		Ind.	—	55	—	50		
I <sub>SB1</sub>	TTL Standby Current (TTL Inputs)	V <sub>DD</sub> = Max., V <sub>IN</sub> = V <sub>IH</sub> or V <sub>IL</sub> CE ≥ V <sub>IH</sub> , f = 0	Com.	—	20	—	20	mA
		Ind.	—	25	—	25		
I <sub>SB2</sub>	CMOS Standby Current (CMOS Inputs)	V <sub>DD</sub> = Max., CE ≥ V <sub>DD</sub> - 0.2V, V <sub>IN</sub> ≥ V <sub>DD</sub> - 0.2V, or V <sub>IN</sub> ≤ 0.2V, f = 0	Com.	—	15	—	15	mA
		Ind.	—	20	—	20		

**Note:**

1. At f = f<sub>MAX</sub>, address and data inputs are cycling at the maximum frequency, f = 0 means no input lines change. Shaded area product in development

**CAPACITANCE<sup>(1)</sup>**

Symbol	Parameter	Conditions	Max.	Unit
C <sub>IN</sub>	Input Capacitance	V <sub>IN</sub> = 0V	6	pF
C <sub>OUT</sub>	Input/Output Capacitance	V <sub>OUT</sub> = 0V	8	pF

**Note:**

1. Tested initially and after any design or process changes that may affect these parameters.

**READ CYCLE SWITCHING CHARACTERISTICS<sup>(1)</sup>** (Over Operating Range)

Symbol	Parameter	-10		-12		Unit
		Min.	Max.	Min.	Max.	
t <sub>RC</sub>	Read Cycle Time	10	—	12	—	ns
t <sub>AA</sub>	Address Access Time	—	10	—	12	ns
t <sub>OHA</sub>	Output Hold Time	2	—	2	—	ns
t <sub>ACE</sub>	$\overline{\text{CE}}$ Access Time	—	10	—	12	ns
t <sub>DOE</sub>	$\overline{\text{OE}}$ Access Time	—	4	—	5	ns
t <sub>HZOE<sup>(2)</sup></sub>	$\overline{\text{OE}}$ to High-Z Output	—	4	—	5	ns
t <sub>LZOE<sup>(2)</sup></sub>	$\overline{\text{OE}}$ to Low-Z Output	0	—	0	—	ns
t <sub>HZCE<sup>(2)</sup></sub>	$\overline{\text{CE}}$ to High-Z Output	0	4	0	6	ns
t <sub>LZCE<sup>(2)</sup></sub>	$\overline{\text{CE}}$ to Low-Z Output	3	—	3	—	ns
t <sub>BA</sub>	$\overline{\text{LB}}, \overline{\text{UB}}$ Access Time	—	4	—	5	ns
t <sub>HZB<sup>(2)</sup></sub>	$\overline{\text{LB}}, \overline{\text{UB}}$ to High-Z Output	0	3	0	4	ns
t <sub>LZB<sup>(2)</sup></sub>	$\overline{\text{LB}}, \overline{\text{UB}}$ to Low-Z Output	0	—	0	—	ns
t <sub>PU</sub>	Power Up Time	0	—	0	—	ns
t <sub>PD</sub>	Power Down Time	—	10	—	12	ns

**Notes:**

- Test conditions assume signal transition times of 3 ns or less, timing reference levels of 1.5V, input pulse levels of 0V to 3.0V and output loading specified in Figure 1.
- Tested with the load in Figure 2. Transition is measured  $\pm 500$  mV from steady-state voltage.

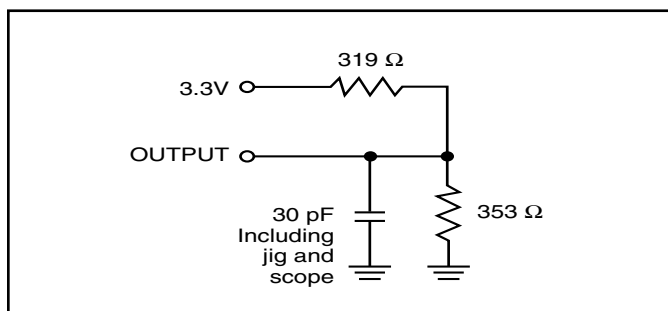
**AC TEST LOADS**

Figure 1

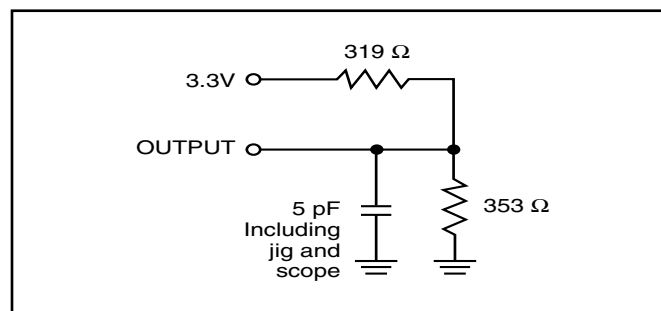


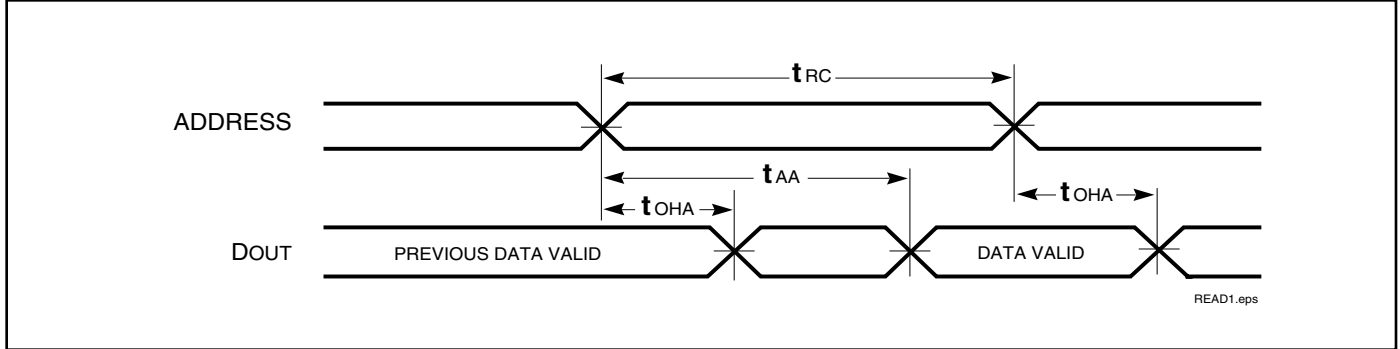
Figure 2

**AC TEST CONDITIONS**

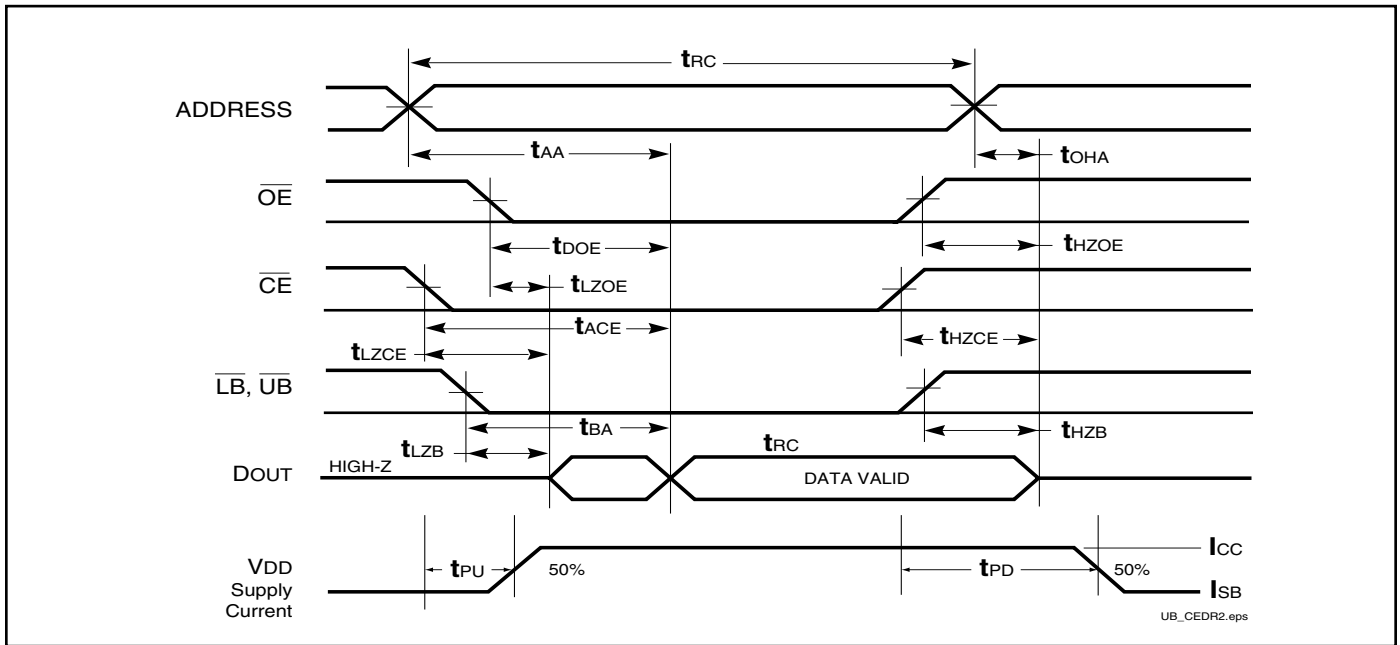
Parameter	Unit
Input Pulse Level	0V to 3.0V
Input Rise and Fall Times	3 ns
Input and Output Timing and Reference Level	1.5V
Output Load	See Figures 1 and 2

AC WAVEFORMS

READ CYCLE NO. 1<sup>(1,2)</sup> (Address Controlled) ( $\overline{CE} = \overline{OE} = V_{IL}$ ,  $\overline{UB}$  or  $\overline{LB} = V_{IL}$ )

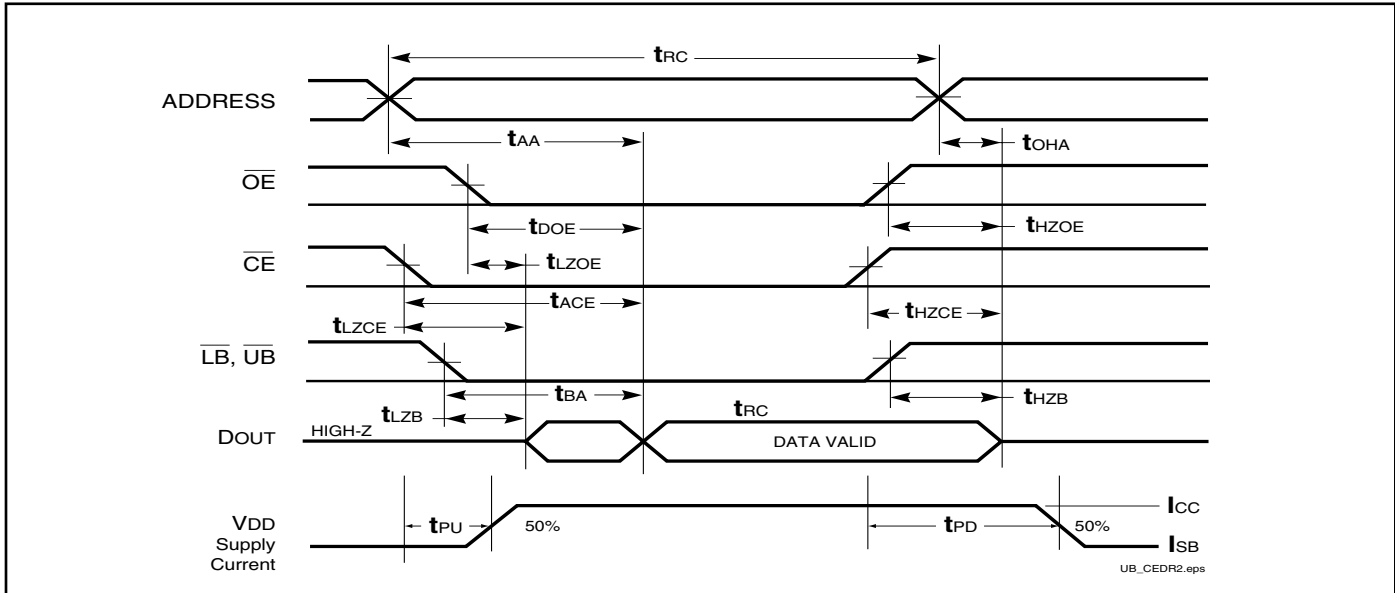


READ CYCLE NO. 2<sup>(1,3)</sup>



Notes:

1.  $\overline{WE}$  is HIGH for a Read Cycle.
2. The device is continuously selected.  $\overline{OE}$ ,  $\overline{CE}$ ,  $\overline{UB}$ , or  $\overline{LB} = V_{IL}$ .
3. Address is valid prior to or coincident with  $\overline{CE}$  LOW transition.

READ CYCLE NO. 2<sup>(1,3)</sup>**Notes:**

1.  $\overline{WE}$  is HIGH for a Read Cycle.
2. The device is continuously selected.  $\overline{OE}$ ,  $\overline{CE}$ ,  $\overline{UB}$ , or  $\overline{LB}$  =  $V_{IL}$ .
3. Address is valid prior to or coincident with  $\overline{CE}$  LOW transition.

**WRITE CYCLE SWITCHING CHARACTERISTICS<sup>(1,3)</sup> (Over Operating Range)**

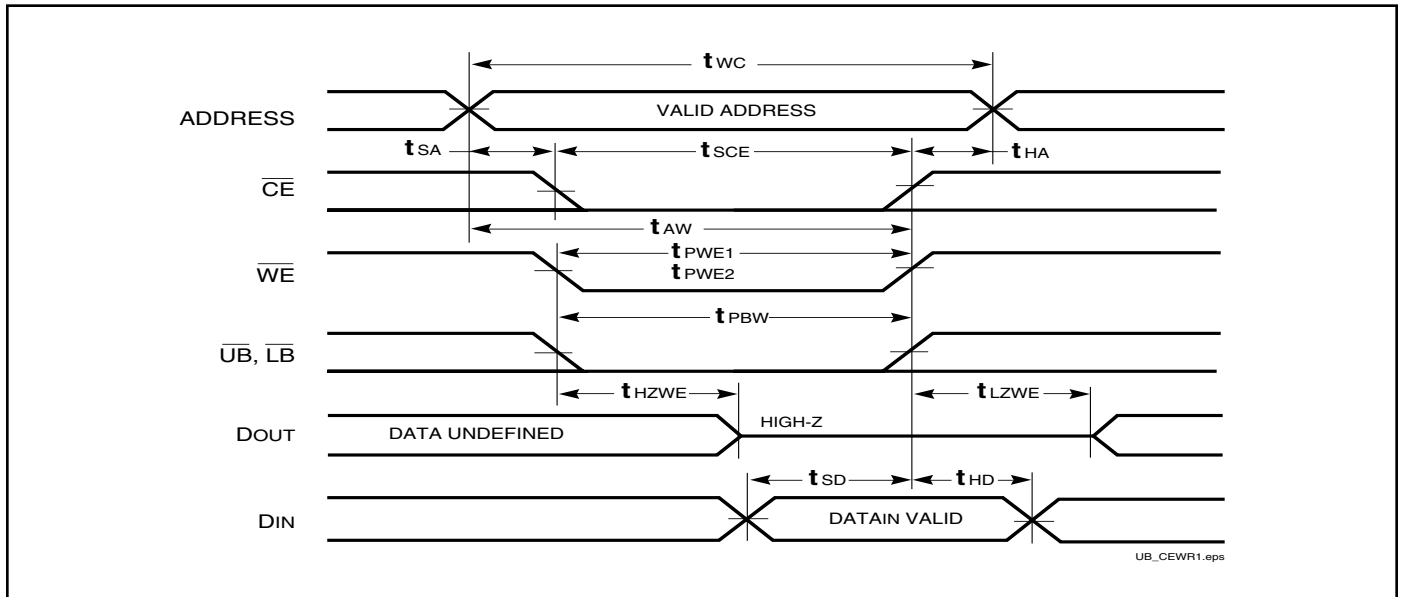
Symbol	Parameter	-10		-12		Unit
		Min.	Max.	Min.	Max.	
$t_{WC}$	Write Cycle Time	10	—	12	—	ns
$t_{SCE}$	$\overline{CE}$ to Write End	8	—	8	—	ns
$t_{AW}$	Address Setup Time to Write End	8	—	8	—	ns
$t_{HA}$	Address Hold from Write End	0	—	0	—	ns
$t_{SA}$	Address Setup Time	0	—	0	—	ns
$t_{PWB}$	$\overline{LB}$ , $\overline{UB}$ Valid to End of Write	8	—	8	—	ns
$t_{PWE1}$	$\overline{WE}$ Pulse Width	8	—	8	—	ns
$t_{PWE2}$	$\overline{WE}$ Pulse Width ( $\overline{OE}$ = LOW)	10	—	12	—	ns
$t_{SD}$	Data Setup to Write End	6	—	6	—	ns
$t_{HD}$	Data Hold from Write End	0	—	0	—	ns
$t_{HZWE}^{(2)}$	$\overline{WE}$ LOW to High-Z Output	—	5	—	6	ns
$t_{LZWE}^{(2)}$	$\overline{WE}$ HIGH to Low-Z Output	2	—	2	—	ns

**Notes:**

1. Test conditions assume signal transition times of 3 ns or less, timing reference levels of 1.5V, input pulse levels of 0V to 3.0V and output loading specified in Figure 1.
2. Tested with the load in Figure 2. Transition is measured  $\pm 500$  mV from steady-state voltage. Not 100% tested.
3. The internal write time is defined by the overlap of  $\overline{CE}$  LOW and  $\overline{UB}$  or  $\overline{LB}$  and  $\overline{WE}$  LOW. All signals must be in valid states to initiate a Write, but any one can go inactive to terminate the Write. The Data Input Setup and Hold timing are referenced to the rising or falling edge of the signal that terminates the write.

AC WAVEFORMS

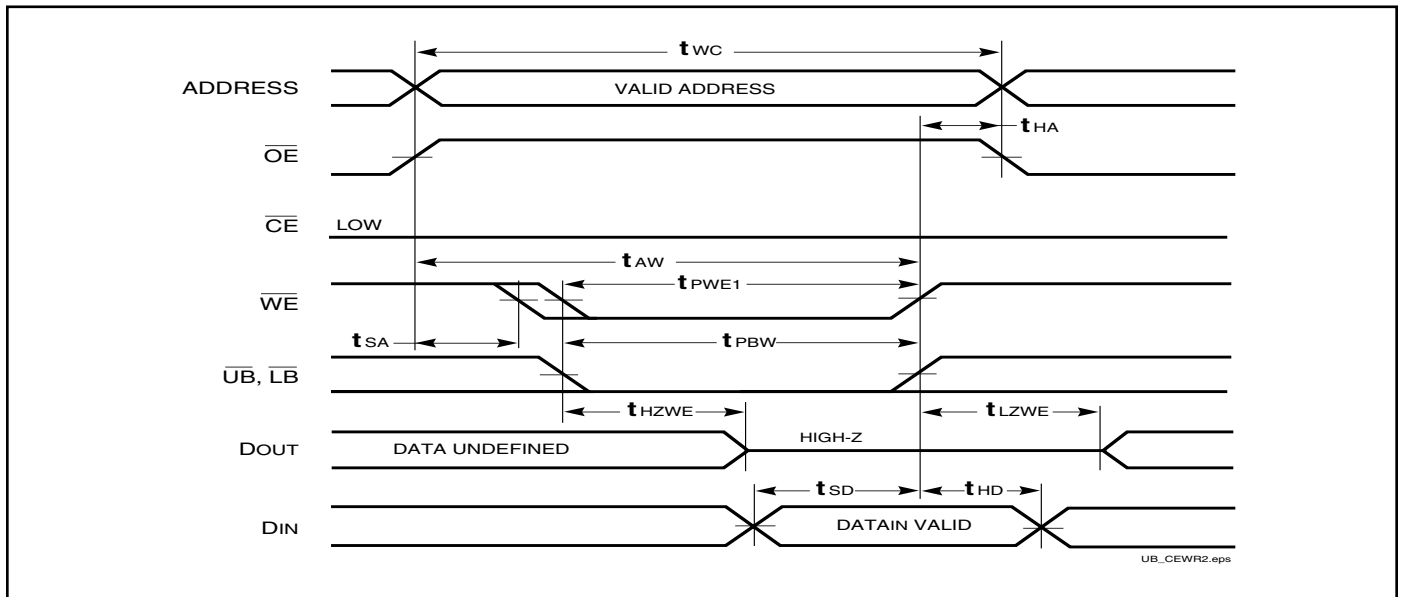
WRITE CYCLE NO. 1 ( $\overline{CE}$  Controlled,  $\overline{OE}$  is HIGH or LOW) <sup>(1)</sup>



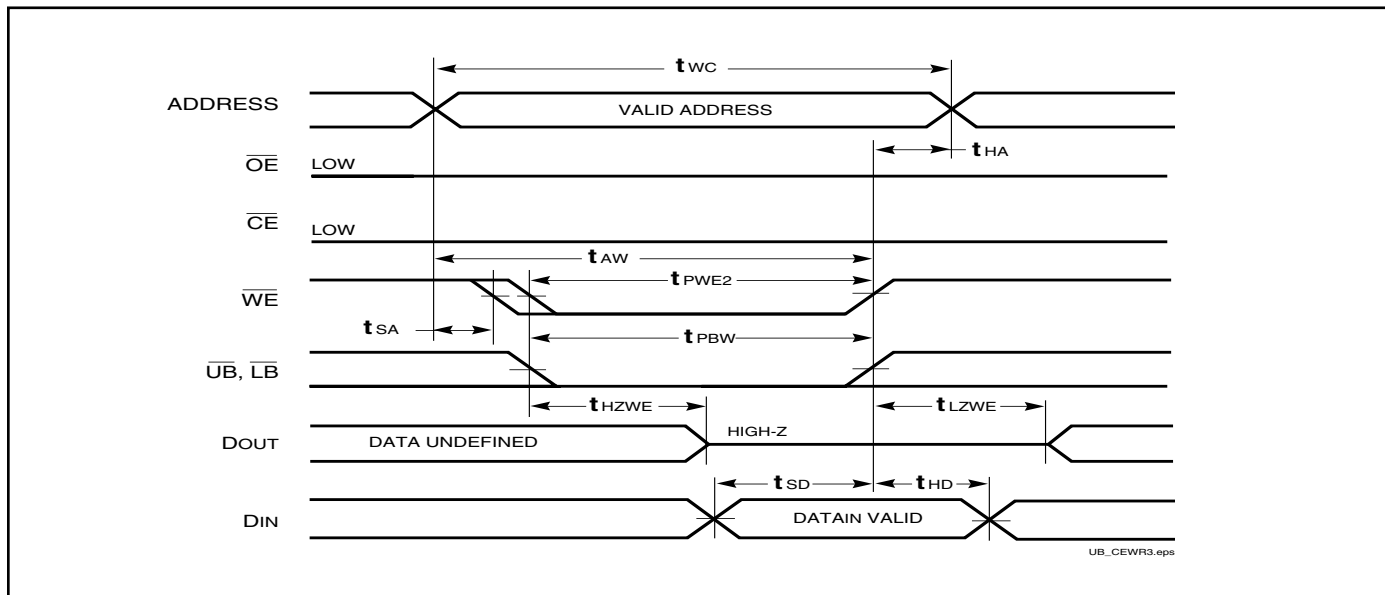
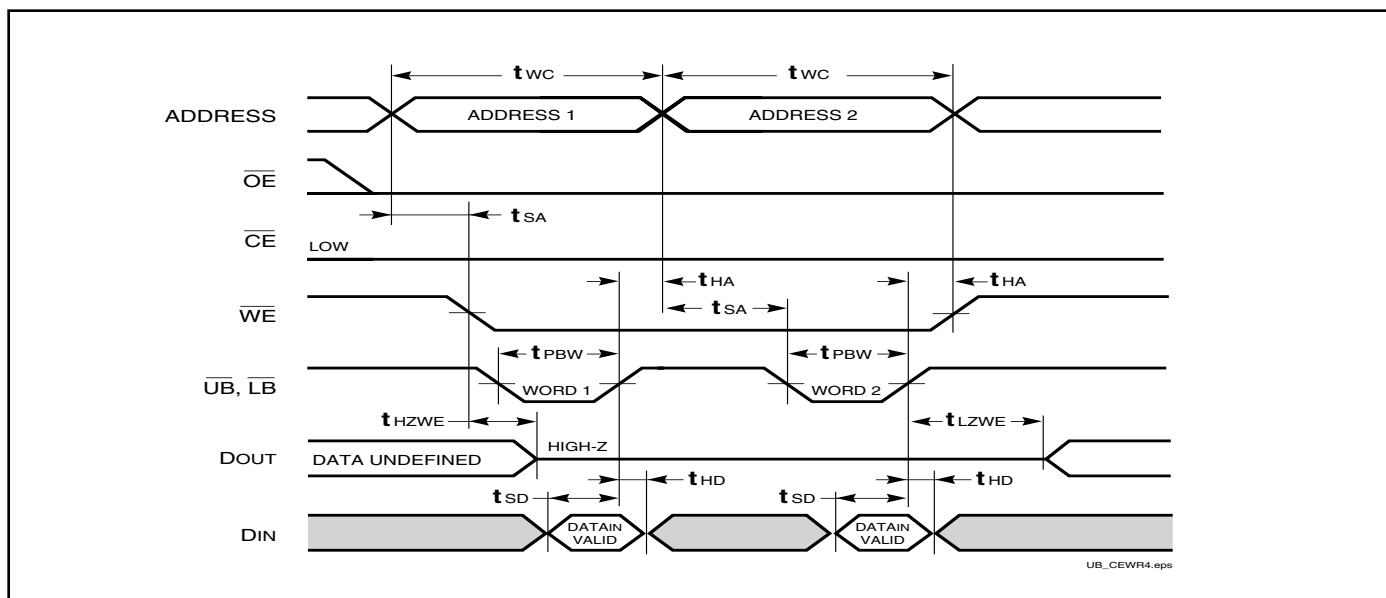
Notes:

1. WRITE is an internally generated signal asserted during an overlap of the LOW states on the  $\overline{CE}$  and  $\overline{WE}$  inputs and at least one of the  $\overline{LB}$  and  $\overline{UB}$  inputs being in the LOW state.
2. WRITE = ( $\overline{CE}$ ) [ ( $\overline{LB}$ ) = ( $\overline{UB}$ ) ] ( $\overline{WE}$ ).

WRITE CYCLE NO. 2 ( $\overline{WE}$  Controlled.  $\overline{OE}$  is HIGH During Write Cycle) <sup>(1,2)</sup>



## AC WAVEFORMS

WRITE CYCLE NO. 3 ( $\overline{WE}$  Controlled,  $\overline{OE}$  is LOW During Write Cycle) <sup>(1)</sup>WRITE CYCLE NO. 4 ( $\overline{LB}$ ,  $\overline{UB}$  Controlled, Back-to-Back Write) <sup>(1,3)</sup>

## Notes:

1. The internal Write time is defined by the overlap of  $\overline{CE} = \text{LOW}$ ,  $\overline{UB}$  and/or  $\overline{LB} = \text{LOW}$ , and  $\overline{WE} = \text{LOW}$ . All signals must be in valid states to initiate a Write, but any can be deasserted to terminate the Write. The  $t_{SA}$ ,  $t_{HA}$ ,  $t_{SD}$ , and  $t_{HD}$  timing is referenced to the rising or falling edge of the signal that terminates the Write.
2. Tested with  $\overline{OE}$  HIGH for a minimum of 4 ns before  $\overline{WE} = \text{LOW}$  to place the I/O in a HIGH-Z state.
3.  $\overline{WE}$  may be held LOW across many address cycles and the  $\overline{LB}$ ,  $\overline{UB}$  pins can be used to control the Write function.



## ORDERING INFORMATION

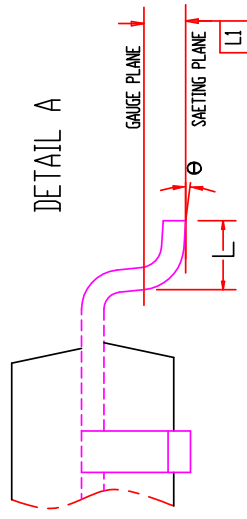
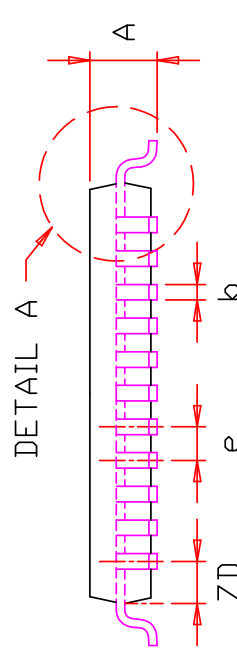
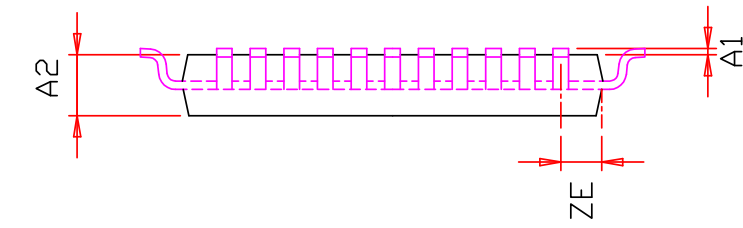
### Commercial Range: 0°C to +70°C

Speed (ns)	Order Part No.	Package
10	IS61LV25616AL-10T	TSOP (Type II)
	IS61LV25616AL-10TL	TSOP (Type II), Lead-free
	IS61LV25616AL-10K	400-mil SOJ
12	IS61LV25616AL-12T	TSOP (Type II)

### Industrial Range: -40°C to +85°C

Speed (ns)	Order Part No.	Package
10	IS61LV25616AL-10TI	TSOP (Type II)
	IS61LV25616AL-10TLI	TSOP (Type II), Lead-free
	IS61LV25616AL-10KI	400-mil SOJ
	IS61LV25616AL-10KLI	400-mil SOJ, Lead-free
	IS61LV25616AL-10LQI	LQFP
	IS61LV25616AL-10LQLI	LQFP, Lead-free
	IS61LV25616AL-10BI	Mini BGA (8mm x 10mm)
	IS61LV25616AL-10BLI	Mini BGA (8mm x 10mm), Lead-free
12	IS61LV25616AL-12TI	TSOP (Type II)

SYMBOL	DIMENSION IN MM		DIMENSION IN INCH	
	MIN.	MAX.	MIN.	MAX.
A	1.40	1.60	0.055	0.063
A1	0.05	0.15	0.002	0.006
A2	1.35	1.45	0.053	0.057
b	0.30	0.45	0.012	0.018
D	11.70	12.30	0.460	0.484
D1	9.87	10.00	0.389	0.399
E	11.70	12.30	0.460	0.484
E1	9.87	10.00	0.389	0.399
e	0.80 BSC.		0.031 BSC.	
L	0.45	0.60	0.018	0.024
L1	0.25 BSC.		0.010 BSC.	
ZD	1.00 REF.		0.039 REF.	
ZE	1.00 REF.		0.039 REF.	
$\theta$	0	3.5°	0	3.5°
		7°		7°

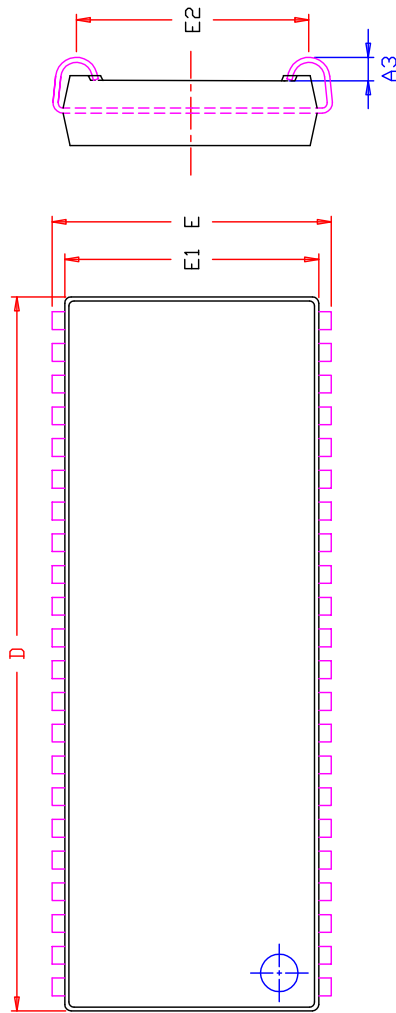


**NOTE :**

1. CONTROLLING DIMENSION : MM
2. DIMENSION D1 AND E1 DO NOT INCLUDE MOLD PROTRUSION.
3. DIMENSION b DOES NOT INCLUDE DAMBAR PROTRUSION/INTRUSION.

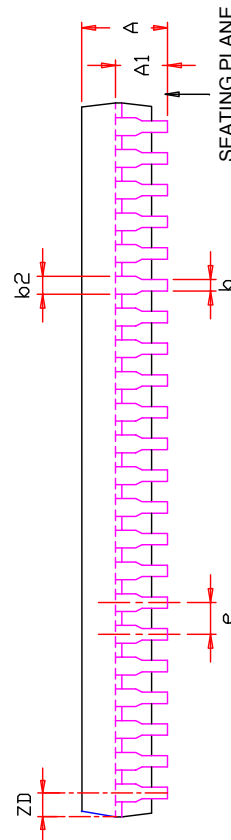
<b>ICSI</b>	TITLE	REV.	DATE
	44L 10x10x1.4mm LQFP (Footprint : 2.0 mm) Package Outline	C	08/30/2001

SYMBOL	DIMENSION IN MM			DIMENSION IN INCH		
	MIN.	NOM.	MAX.	MIN.	NOM.	MAX.
A	3.25		3.76	0.128		0.148
A1	2.08			0.082		
A3	0.635			0.025		
k	0.38		0.51	0.015		0.020
b2	0.66	0.71	0.81	0.026	0.028	0.032
D	28.45	28.58	28.70	1.120	1.125	1.130
E	11.05	11.18	11.30	0.435	0.440	0.445
E1	10.03	10.16	10.29	0.395	0.400	0.405
E2		9.40	BSC.		0.370	BSC.
e		1.27	BSC.		0.050	BSC.
ZD		0.95	REF.		0.037	REF.



**NOTE :**

1. Controlling dimension : mm
2. Dimension D and E1 do not include mold protrusion .
3. Dimension b2 does not include dambar protrusion/intrusion.
4. Formed leads shall be planar with respect to one another within 0.1mm at the seating plane after final test.
5. Reference document : JEDEC SPEC MS-027.



TITLE

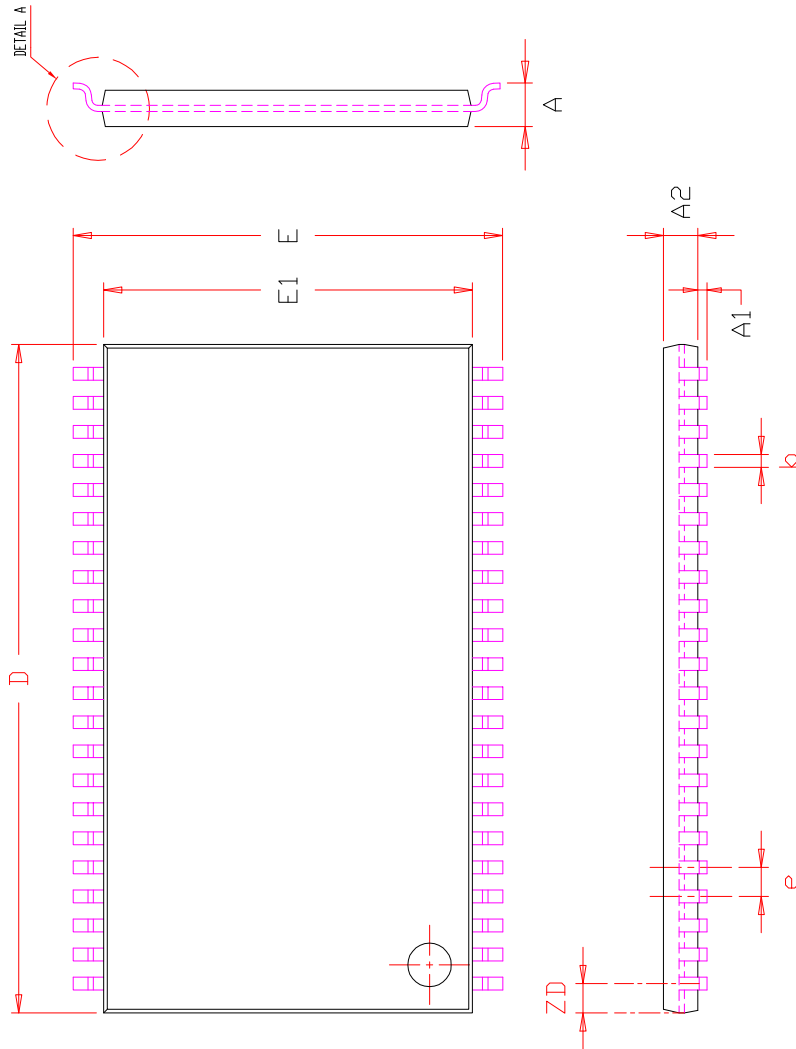
44L 400mil SOJ  
Package Outline

REV.

E

DATE

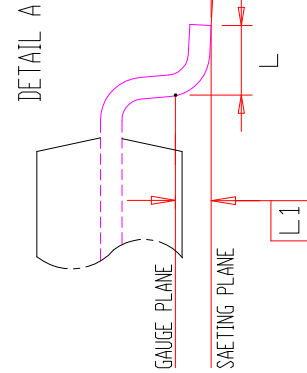
12/21/2007



SYMBOL	DIMENSION IN MM			DIMENSION IN INCH		
	MIN.	NOM.	MAX.	MIN.	NOM.	MAX.
A	1.00		1.20	0.039		0.047
A1	0.05		0.15	0.002		0.006
A2	0.95	1.00	1.05	0.037	0.039	0.041
b	0.30		0.45	0.012		0.018
D	18.28	18.41	18.54	0.720	0.725	0.730
E	11.56	11.76	11.96	0.455	0.463	0.471
E1	10.03	10.16	10.29	0.395	0.400	0.405
e	0.80	BSC.	0.031	BSC.		
L	0.40		0.69	0.016		0.027
L1	0.25	BSC.	0.010	BSC.		
ZD	0.805	REF.	0.032	REF.		
⊕	0		8°	0		8°

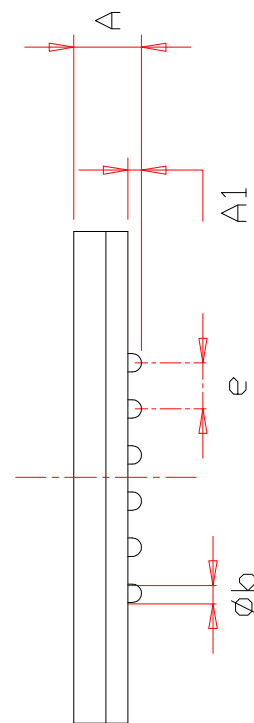
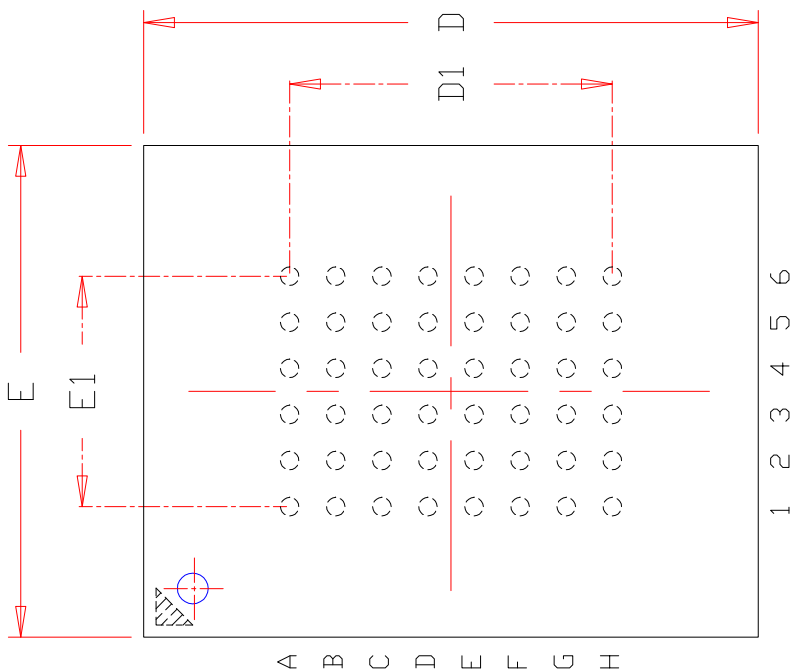
**NOTE :**

1. CONTROLLING DIMENSION : MM
2. DIMENSION D AND E1 DO NOT INCLUDE MOLD PROTRUSION.
3. DIMENSION b DOES NOT INCLUDE DAMBAR PROTRUSION/INTRUSION.



	TITLE	REV.	DATE
	44L 400mil TSOP-2 Package Outline	F	06/04/2008

TOP VIEW



SYM.	DIMENSION (mm)			DIMENSION (inch)		
	MIN.	NOM.	MAX.	MIN.	NOM.	MAX.
A	—	—	1.20	—	—	0.047
A1	0.20	0.25	0.30	0.008	0.010	0.012
b	0.30	0.35	0.40	0.012	0.014	0.016
D	9.90	10.00	10.10	0.390	0.394	0.398
D1	5.25 BSC			0.207 BSC		
E	7.90	8.00	8.10	0.311	0.315	0.319
E1	3.75BSC			0.148BSC		
ⓔ	0.75 BSC			0.030 BSC		

**NOTE :**

1. Controlling dimension : mm
2. Reference document : JEDEC MO-207

	TITLE	REV.	DATE
	48L 8x10mm TF-BGA Package Outline	C	08/12/2008

## Looking for pricing, stock, or lifecycle information?

Click below to explore more details on WIN SOURCE:

-  [View IS61LV25616AL-10TL-TR on WIN SOURCE](#)
-  [ISSI, Integrated Silicon Solution Inc Information](#)

## Optimize Your Supply Chain with WIN SOURCE Solutions

-  Global Sourcing Solution
-  Obsolete Management
-  Cost Control Management
-  Shortage Management
-  Alternative Solution
-  Excess Inventory Management