



IQS7223 OVERVIEW

WearMax™ Capacitive Touch and Proximity Controller for accurate long-term and power-on presence detection with I2C communications interface, configurable GPIOs and low power options

1 Device Overview

The IQS7223 ProxFusion® IC is a sensor fusion device for various long-term wear or presence detection purposes. The sensor is fully I²C compatible and on-chip calculations enable the IC to respond effectively even in lowest power modes.

1.1 Main Features

- > Highly flexible ProxFusion® device
- > 9 sensor pad connections (QFN-20) / 8 sensor pad connections (WLCSP-18)
- > Dedicated WearMax™ Sensor implementation for optimal wear / presence detection
- > Built-in basic functions:
 - Dedicated Intelligent Wear Output
 - Differential measurements (Advanced reference channel capabilities)
 - Automatic tuning
 - Noise filtering
 - Debounce & hysteresis
- > Design simplicity
 - PC Software for debugging and obtaining optimal settings and performance
 - One-time programmable settings for custom power-on IC configuration
 - Auto-run from programmed settings for simplified integration
- > Automated system power modes for optimal response vs consumption
- > I2C communication interface with IRQ/RDY(up to fast plus -1MHz)
- > Event and streaming modes
- > Customizable user interface due to programmable memory
- > Supply Voltage 1.8V(-5%)to 3.5V
- > Small packages
 - WLCSP18 (1.62 x 1.62 x 0.5 mm) - interleaved 0.4mm x 0.6mm ball pitch
 - QFN20 (3 x 3 x 0.5 mm) - 0.4mm pitch

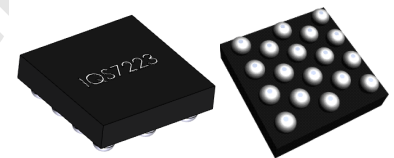

WLCSP18 & QFN20
package
Representation only

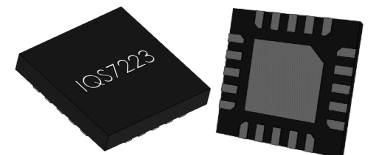

1.2 Applications

- > Fitness band & Smartwatch Wear Detection
- > Headphone Wear Detection
- > TWS Earbud Wear Detection



1.3 Block Diagram

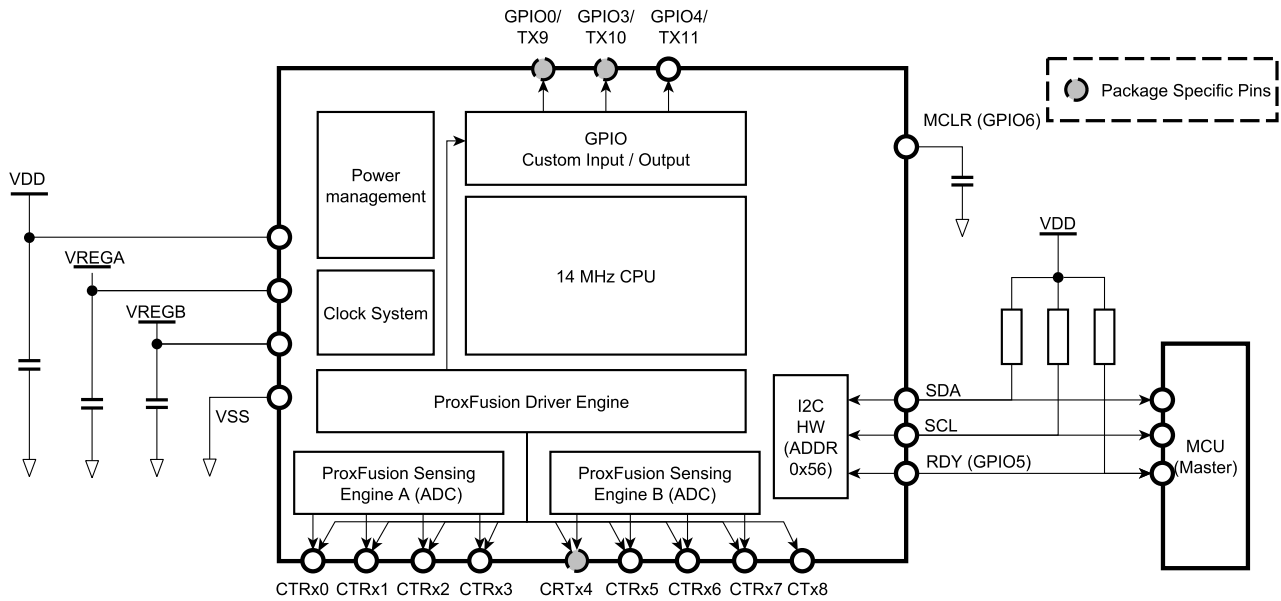

Figure 1.1: Functional Block Diagram

Preliminary

ⁱWLCSP18 packages do not have a CRX4 and combines GPIO0 and GPIO3



2 Hardware Connection

2.1 WLCSP18 Pin Diagrams

Table 2.1: 18-pin WLCSP18 Package (Bottom/Ball-side View)

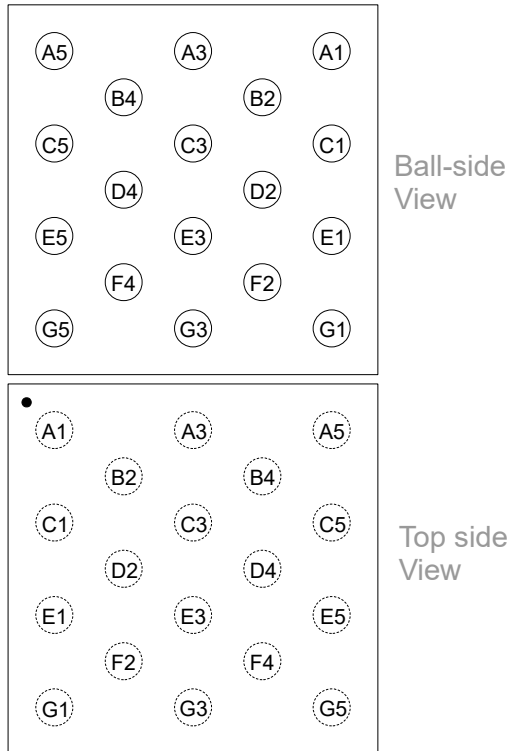

Pin no.	Signal
A5	GPIO6 / MCLR
A3	SCL/ GPIO2
A1	Tx9/Tx10/GPIO0/GPIO3 ⁱ
B4	SDA/GPIO1
B2	Tx11/GPIO4
C5	Vdd
C3	RDY/ GPIO5
C1	Tx8
D4	Vss
D2	CRx2/Tx2
E5	VregD
E3	CRx1/Tx1
E1	CRx6/Tx6
F4	CRx0/Tx0
F2	CRx5/Tx5
G5	VregA
G3	CRx3/Tx3
G1	CRx7/Tx7

2.2 QFN20 Pin Diagram

Table 2.2: 20-pin QFN Package (Top View)

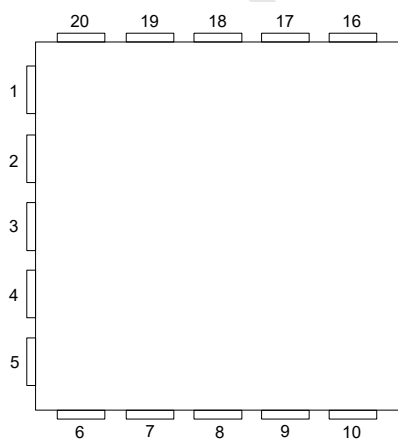

Pin no.	Signal name	Pin no.	Signal name
1	VDD	11	CRx6
2	VREGD	12	CRx7
3	VSSD & VSSA	13	CTx8
4	VREGA	14	GPIO0
5	CRx0	15	GPIO3
6	CRx1	16	GPIO4
7	CRx2	17	GPIO5
8	CRx3	18	GPIO2
9	CRx4	19	GPIO1
10	CRx5	20	GPIO6

Area name	Signal name
Tab	Float

ⁱPlease note that CTx9 and CTx10 are shorted in the WLCSP18 package



2.3 Reference Schematic

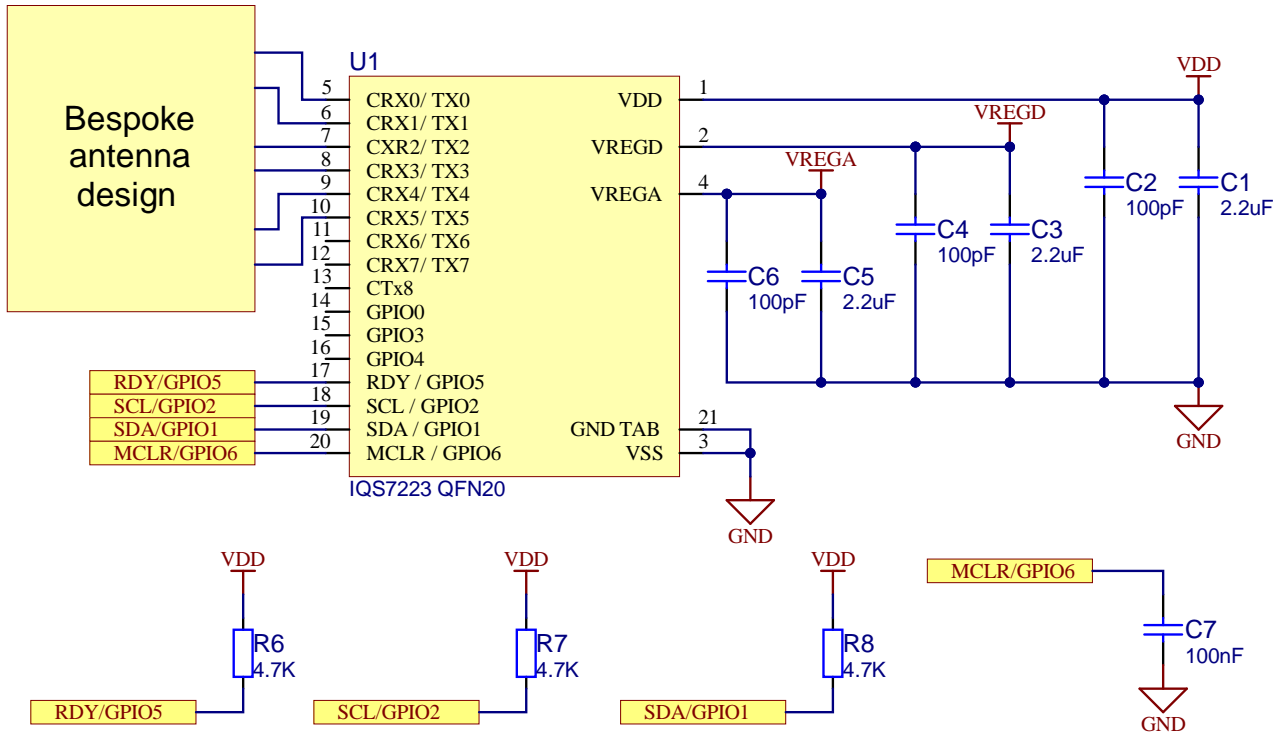

Figure 2.1: IQS7223 Reference Schematic

Preliminary



3 Electrical Characteristics

3.1 Absolute Maximum Ratings

	Min	Max	Unit
Voltage applied at VDD pin to VSS	1.71	3.5	V
Voltage applied to any ProxFusion® pin	-0.3	VREG	V
Voltage applied to any other pin (referenced to VSS)	-0.3	VDD + 0.3 (3.5V max)	V
Storage temperature, T _{stg}	-40	85	°C

3.2 ESD Rating

	Value	Unit
V _(ESD) Electrostatic discharge Human-body model (HBM), per ANSI/ESDA/JEDEC JS-001 ⁱ	± 4000	V

3.3 Recommended Operating Conditions

Recommended operating conditions		Min	Nom	Max	Unit
VDD	Supply voltage applied at VDD pin	1.71		3.5	V
VregA	Analog-domain Regulator output at VregA	1.5	1.53	1.75	V
VregD	Digital-domain Regulator output at VregD	1.57	1.59	1.8 ⁱⁱ	V
VSS	Supply voltage applied at VSS pin	0	0	0	V
T _A	Operating free-air temperature	-40	25	85	°C
C _{VDD}	Recommended capacitor at VDD	1	2	10	μF
C _{VREGA}	Recommended external buffer capacitor at VREG, ESR ≤ 200mΩ	1	2	10	μF
C _{VREGD}	Recommended external buffer capacitor at VREG, ESR ≤ 200mΩ	1	2	10	μF
C _{X_SELF-VSS}	Maximum capacitance of all external electrodes on all ProxFusion® blocks (self-capacitance mode)	-	-	400	pF
C _{m_CTX-CRX}	Capacitance of all external electrodes on all ProxFusion® blocks (mutual-cap mode)	0.1	-	90	pF
C _{X_CRX-VSS-1M}	Maximum capacitance of all external electrodes on all ProxFusion® blocks (mutual-capacitance mode @ f _{xfer} =1MHz)			100	pF
C _{X_CRX-VSS-4M}	Maximum capacitance of all external electrodes on all ProxFusion® blocks (mutual-capacitance mode @ f _{xfer} =4MHz sensing)			25	pF
$\frac{C_{X_{CRX-VSS}}}{C_{m_{CTX-CRX}}}$	Capacitance ratio for optimal SNR in mutual capacitance mode	10		20	n/a
RC _{X_CRX/CTX}	Series (in-line) resistance of all mutual capacitance pins (Tx & Rx pins) in mutual capacitance mode	0 ⁱⁱⁱ	0.47	10 ^{iv}	kΩ
RC _{X_SELF}	Series (in-line) resistance of all self capacitance pins in self capacitance mode	0 ⁱⁱ	0.47	10 ^{iv}	kΩ

ⁱ JEDEC document JEP155 states that 500-V HBM allows safe manufacturing with a standard ESD control process. Pins listed as ±4000 V may actually have higher performance.

ⁱⁱ V_{dd} ≥ 2V

ⁱⁱⁱ Nominal series resistance of 470Ω is recommended to prevent received and emitted EMI effects. Typical resistance also adds additional ESD protection

^{iv} Series resistance limit is a function of f_{xfer} and the circuit time constant, RC. R_{max} × C_{max} = $\frac{1}{(6 \times f_{xfer})}$ where "C" is the pin capacitance to Vss.



4 Ordering Information

IQS7223 y zzz ppb

IC NAME	IQS7223	=	IQS7223	
MINOR PRODUCT REVISION	y	=	A	Default
POWER-ON CONFIGURATION	zzz	=	000	I ² C with initialize settings requirement
PACKAGE TYPE	pp	=	CS	WLCSP-18 package
		=	QN	QFN-20 package
BULK PACKAGING	b	=	R	WLCSP-18 Reel (3000pcs/reel)
				QFN-20 Reel (2000pcs/reel)

Figure 4.1: Order Code Description

Preliminary

5 Package Specification

5.1 Package Outline Description - WLCSP18

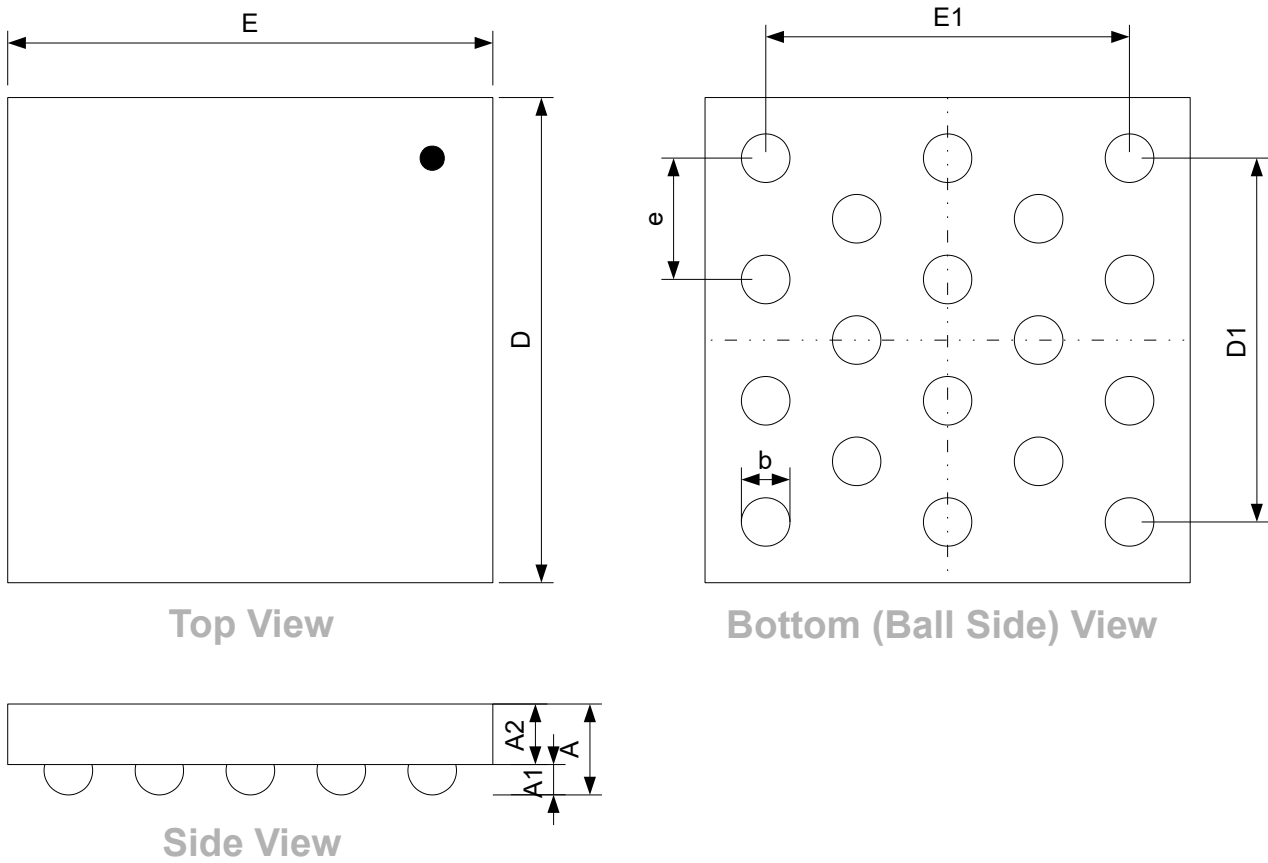

Figure 5.1: WLCSP (1.62x1.62) - 18 Package Outline Visual Description

Table 5.1: WLCSP (1.62x1.62) - 18 Package Outline Visual Description

Dimension	[mm]	Dimension	[mm]
A	0.525±0.05	D1	1.2
A1	0.2±0.02	E	1.620±0.015
A2	0.3±0.025	E1	1.2
b	0.260±0.39	e	0.4
D	1.620±0.015		



5.2 Package Outline Description - QFN20

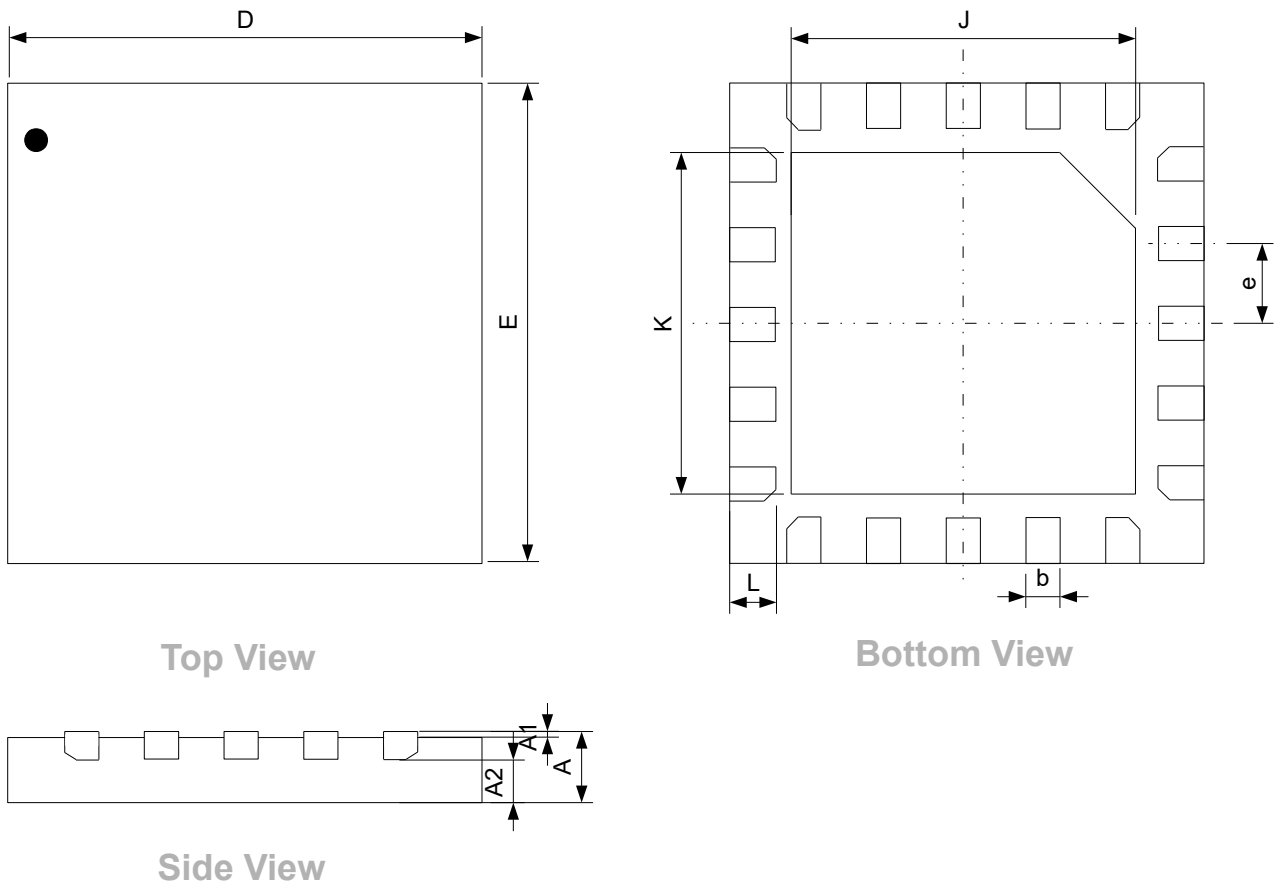

Figure 5.2: QFN (3x3)-20 Package Outline Visual Description

Table 5.2: QFN (3x3)-20 Package Outline Visual Description

Dimension	[mm]	Dimension	[mm]
A	0.5±0.1	E	3
A1	0.035±0.05	e	0.4
A2	0.3	J	1.7±0.1
A3	0.203	K	1.7±0.1
b	0.2±0.05	L	0.4±0.05
D	3		



Contact Information

	USA	Asia	South Africa
Physical Address	11940 Jollyville Rd Suite 120-S Austin TX-78759 USA	Room501A, Block A T-Share International Centre Taoyuan Road Nanshan District Shenzen Guangdong Province PRC	1 Bergsig Avenue Paarl 7646 South Africa South Africa
Postal Address	11940 Jollyville Rd Suite 120-S Austin TX-78759 USA	Room501A, Block A T-Share International Centre Taoyuan Road Nanshan District Shenzen Guangdong Province PRC	PO Box 3534 Paarl 7620 South Africa South Africa
Tel	+1 512 538 1995	+86 755 8303 5294 ext 808	+27 21 863 0033
Email	info@azoteq.com	info@azoteq.com	info@azoteq.com

Visit www.azoteq.com
for a list of distributors and worldwide representation.



Patents as listed on www.azoteq.com/patents-trademarks/ may relate to the device or usage of the device

Azoteq®, Crystal Driver®, IQ Switch®, ProxSense®, ProxFusion®, LightSense™, SwipeSwitch™, and the  logo are trademarks of Azoteq.

The information in this Datasheet is believed to be accurate at the time of publication. Azoteq uses reasonable effort to maintain the information up-to-date and accurate, but does not warrant the accuracy, completeness or reliability of the information contained herein. All content and information are provided on an "as is" basis only, without any representations or warranties, express or implied, of any kind, including representations about the suitability of these products or information for any purpose. Azoteq disclaims all warranties and conditions with regard to these products and information, including but not limited to all implied warranties and conditions of merchantability, fitness for a particular purpose, title and non-infringement of any third party intellectual property rights. Azoteq assumes no liability for any damages or injury arising from any use of the information or the product or caused by, without limitation, failure of performance, error, omission, interruption, defect, delay in operation or transmission, even if Azoteq has been advised of the possibility of such damages. The applications mentioned herein are used solely for the purpose of illustration and Azoteq makes no warranty or representation that such applications will be suitable without further modification, nor recommends the use of its products for application that may present a risk to human life due to malfunction or otherwise. Azoteq products are not authorized for use as critical components in life support devices or systems. No licenses to patents are granted, implicitly, express or implied, by estoppel or otherwise, under any intellectual property rights. In the event that any of the abovementioned limitations or exclusions does not apply, it is agreed that Azoteq's total liability for all losses, damages and causes of action (in contract, tort (including without limitation, negligence) or otherwise) will not exceed the amount already paid by the customer for the products. Azoteq reserves the right to alter its products, to make corrections, deletions, modifications, enhancements, improvements and other changes to the content and information, its products, programs and services at any time or to move or discontinue any contents, products, programs or services without prior notification. For the most up-to-date information and binding Terms and Conditions please refer to www.azoteq.com.

Looking for pricing, stock, or lifecycle information?

Click below to explore more details on WIN SOURCE:

-  [View IQS7223C001CSR on WIN SOURCE](#)
-  [Azoteq \(Pty\) Ltd Information](#)

Optimize Your Supply Chain with WIN SOURCE Solutions

-  Global Sourcing Solution
-  Obsolete Management
-  Cost Control Management
-  Shortage Management
-  Alternative Solution
-  Excess Inventory Management