



**THE DATASHEET OF
ISL6312ACRZ-T**



ISL6312A

Four-Phase Buck PWM Controller with Integrated MOSFET Drivers for Intel VR10, VR11, and AMD Applications

FN9290
Rev 6.00
January 22, 2015

The ISL6312A four-phase PWM control IC provides a precision voltage regulation system for advanced microprocessors. The integration of power MOSFET drivers into the controller IC marks a departure from the separate PWM controller and driver configuration of previous multiphase product families. By reducing the number of external parts, this integration is optimized for a cost and space saving power management solution.

One outstanding feature of this controller IC is its multi-processor compatibility, allowing it to work with both Intel and AMD microprocessors. Included are programmable VID codes for Intel VR10, VR11, as-well-as AMD DAC tables. A unity gain, differential amplifier is provided for remote voltage sensing, compensating for any potential difference between remote and local grounds. The output voltage can also be positively or negatively offset through the use of a single external resistor.

The ISL6312A also includes advanced control loop features for optimal transient response to load apply and removal. One of these features is highly accurate, fully differential, continuous DCR current sensing for load-line programming and channel current balance. Active pulse positioning (APP) modulation is another unique feature, allowing for quicker initial response to high di/dt load transients.

This controller also allows the user the flexibility to choose between PHASE detect or LGATE detect adaptive deadtime schemes. This ability allows the ISL6312A to be used in a multitude of applications where either scheme is required.

Protection features of this controller IC include a set of sophisticated overvoltage, undervoltage, and overcurrent protection. Furthermore, the ISL6312A includes protection against an open circuit on the remote sensing inputs. Combined, these features provide advanced protection for the microprocessor and power system.

Features

- Integrated multiphase power conversion
 - 2-phase or 3-phase operation with internal drivers
 - 4-phase operation with external PWM driver signal
- Precision core voltage regulation
 - Differential remote voltage sensing
 - $\pm 0.5\%$ system accuracy over-temperature
 - Adjustable reference-voltage offset
- Optimal transient response
 - Active pulse positioning (APP) modulation
 - Adaptive phase alignment (APA)
- Fully differential, continuous DCR current sensing
 - Accurate load-line programming
 - Precision channel current balancing
- User selectable adaptive deadtime scheme
 - PHASE detect or LGATE detect for application flexibility
- Variable gate drive bias: 5V to 12V
- Multi-processor compatible
 - Intel VR10 and VR11 modes of operation
 - AMD mode of operation
- Microprocessor voltage identification inputs
 - 8-bit DAC
 - Selectable between intel's extended VR10, VR11, AMD 5-bit, and AMD 6-bit DAC tables
 - Dynamic VID technology
- Overcurrent protection
- Load current indicator
- Multi-tiered overvoltage protection
- Digital soft-start
- Selectable operation frequency up to 1.5MHz per phase
- Pb-free (RoHS compliant)

Ordering Information

PART NUMBER (Notes 1, 2, 3)	PART MARKING	TEMP. (°C)	PACKAGE (Pb-Free)	PKG. DWG. #
ISL6312ACRZ	ISL6312 ACRZ	0 to +70	48 Ld 7x7 QFN	L48.7x7
ISL6312AIRZ	ISL6312 AIRZ	-40 to +85	48 Ld 7x7 QFN	L48.7x7

NOTES:

1. Add "-T*" suffix for tape and reel. Please refer to [TB347](#) for details on reel specifications.
2. These Intersil Pb-free plastic packaged products employ special Pb-free material sets, molding compounds/die attach materials, and 100% matte tin plate plus anneal (e3 termination finish, which is RoHS compliant and compatible with both SnPb and Pb-free soldering operations). Intersil Pb-free products are MSL classified at Pb-free peak reflow temperatures that meet or exceed the Pb-free requirements of IPC/JEDEC J STD-020.
3. For Moisture Sensitivity Level (MSL), please see product information page for [ISL6312A](#). For more information on MSL, please see tech brief [TB363](#).

Pinout

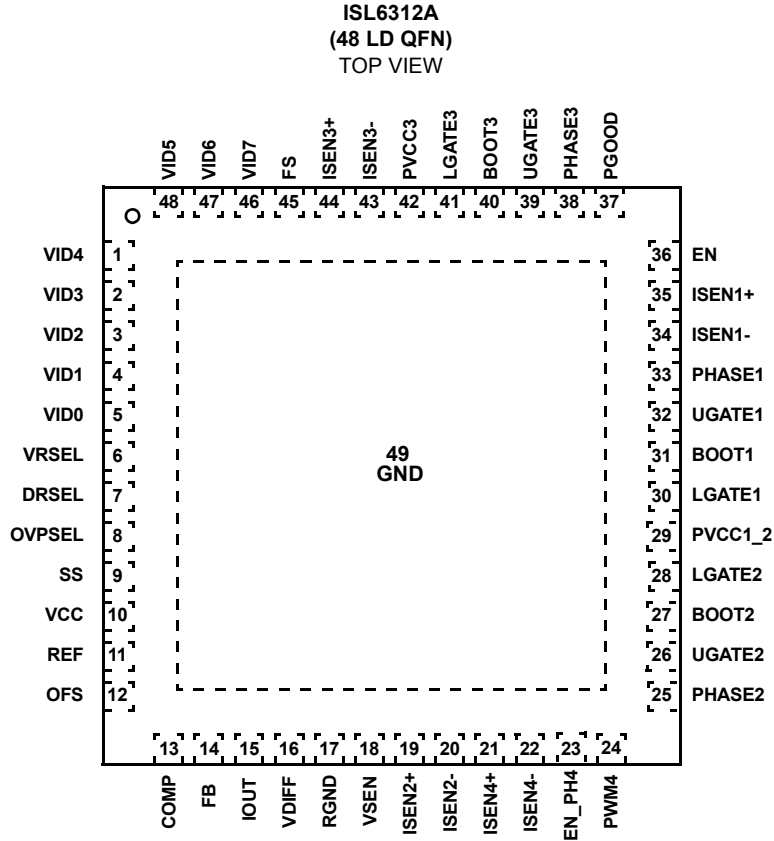

ISL6312A Integrated Driver Block Diagram

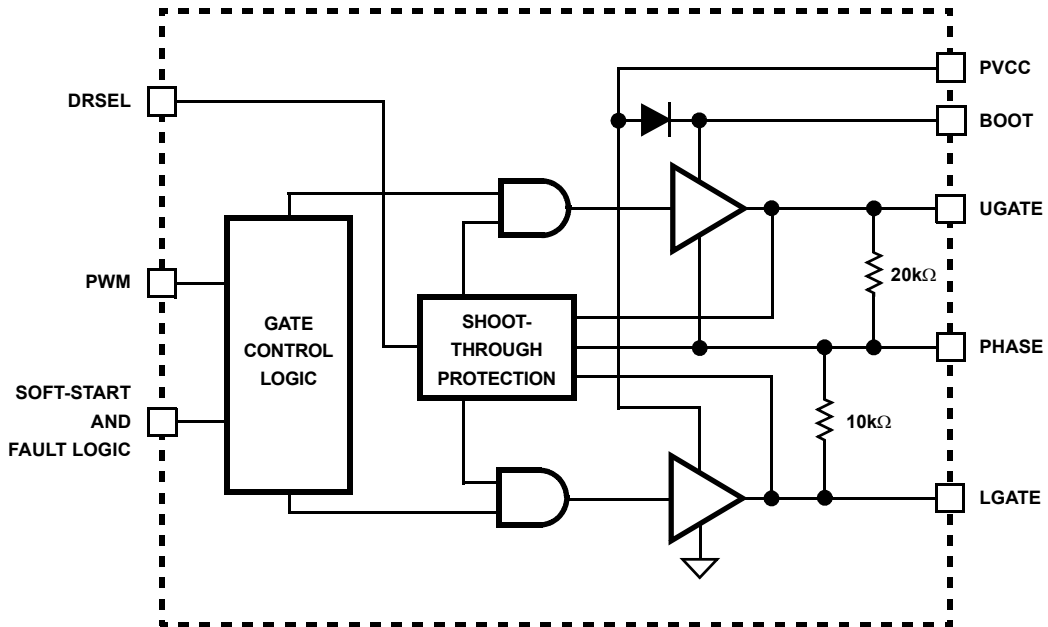

Block Diagram

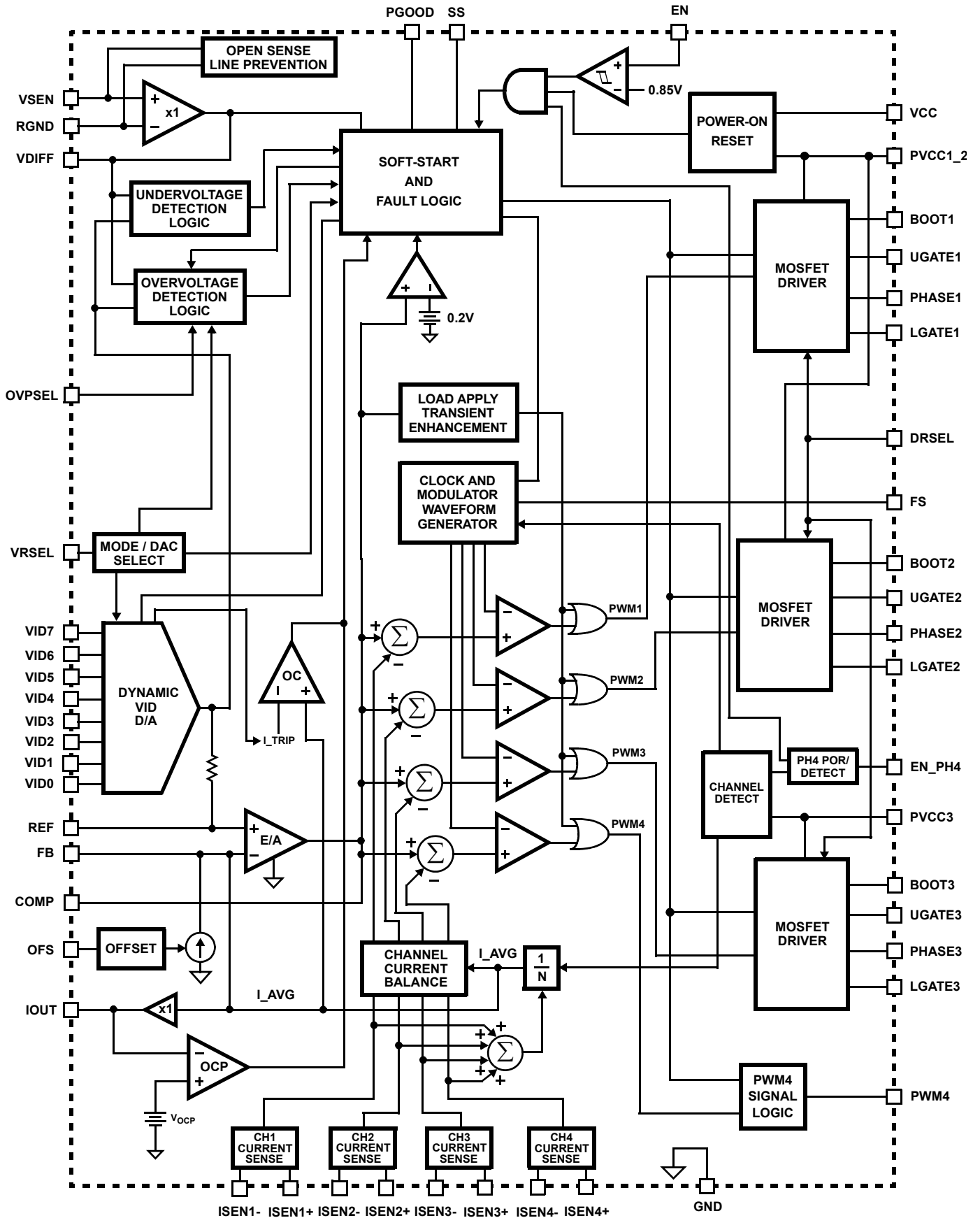

Typical Application - ISL6312A (4-Phase)

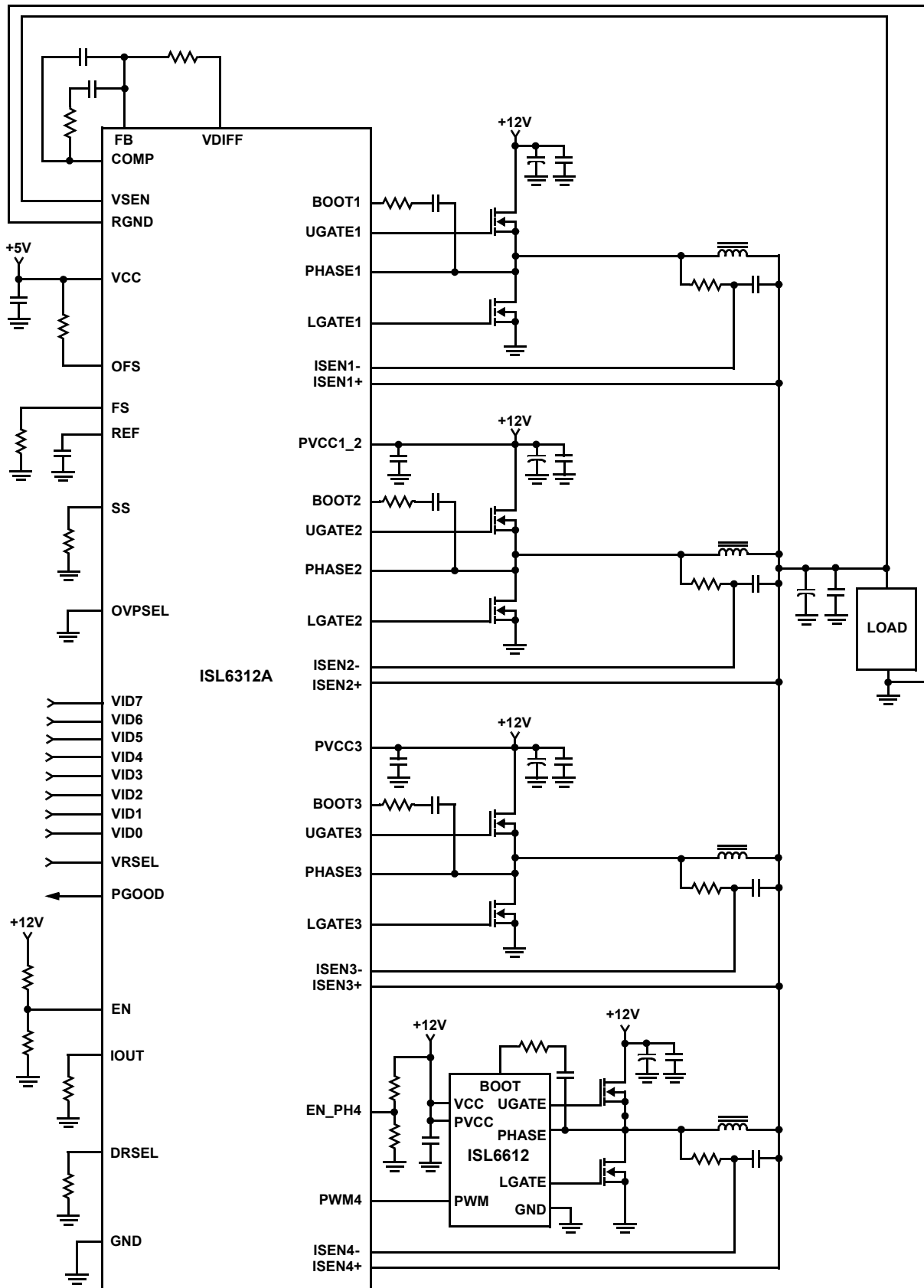

Typical Application - ISL6312A with NTC Thermal Compensation (4-Phase)

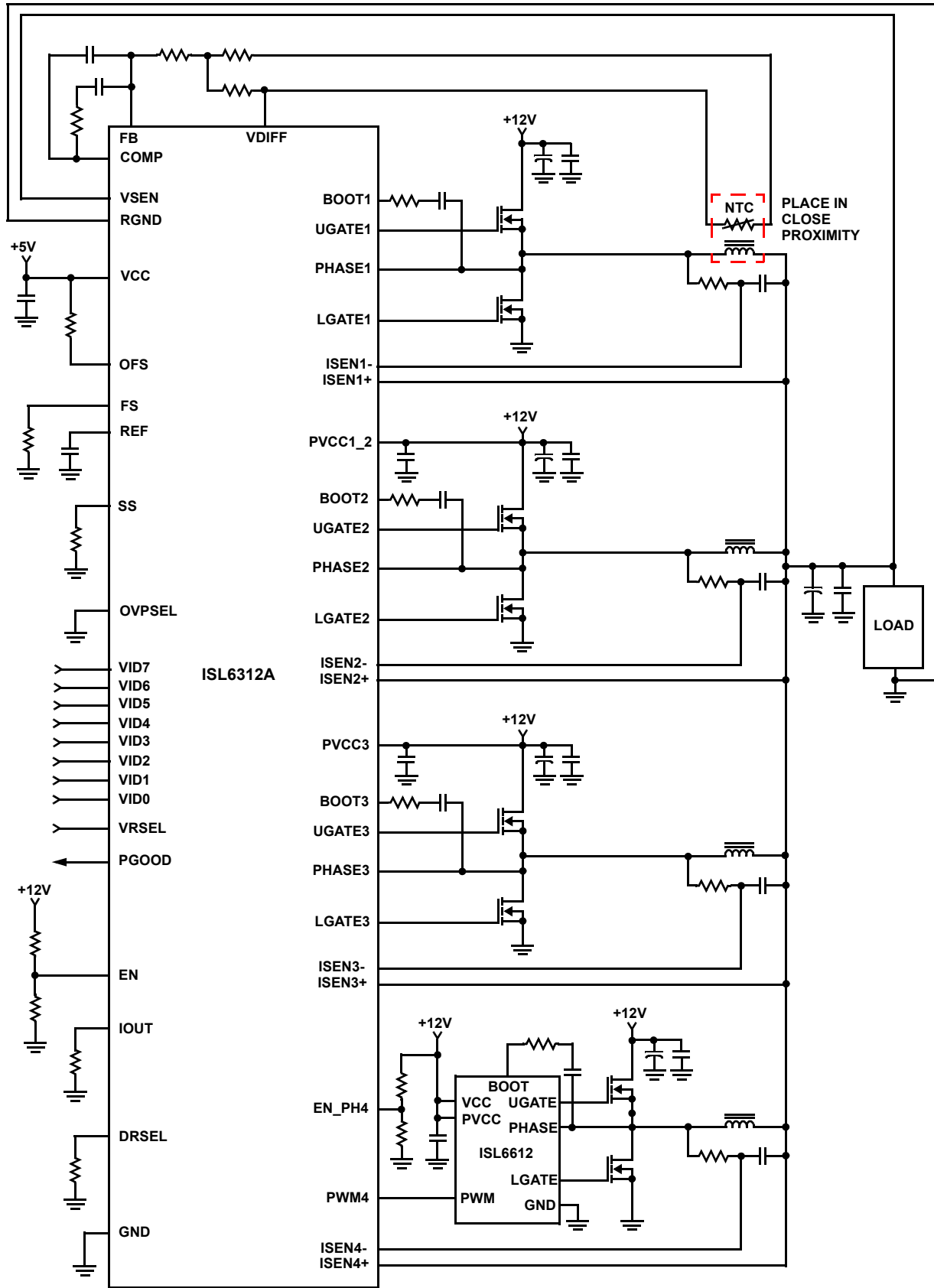

Absolute Maximum Ratings

Supply Voltage, VCC	-0.3V to +6V
Supply Voltage, PVCC	-0.3V to +15V
BOOT Voltage, V _{BOOT}	GND - 0.3V to GND + 36V
BOOT to PHASE Voltage, V _{BOOT-PHASE}	-0.3V to 15V (DC) -0.3V to 16V (<10ns, 10μJ)
PHASE Voltage, V _{PHASE}	GND - 0.3V to 15V (PVCC = 12) GND - 8V (<400ns, 20μJ) to 24V (<200ns, V _{BOOT} - PHASE = 12V)
UGATE Voltage, V _{UGATE}	V _{PHASE} - 0.3V to V _{BOOT} + 0.3V V _{PHASE} - 3.5V (<100ns Pulse Width, 2μJ) to V _{BOOT} + 0.3V
LGATE Voltage, V _{LGATE}	GND - 0.3V to PVCC + 0.3V GND - 5V (<100ns Pulse Width, 2μJ) to PVCC + 0.3V
Input, Output, or I/O Voltage	GND - 0.3V to VCC + 0.3V
ESD Classification	Class I JEDEC STD

Thermal Information

Thermal Resistance	θ_{JA} (°C/W)	θ_{JC} (°C/W)
QFN Package (Notes 4, 5)	27	2
Maximum Junction Temperature	+150°C	
Maximum Storage Temperature Range	-65°C to +150°C	
Pb-Free Reflow Profile	see TB493	

Recommended Operating Conditions

VCC Supply Voltage	+5V ±5%
PVCC Supply Voltage	+5V to 12V ±5%
Ambient Temperature	0°C to +70°C (ISL6312ACRZ)
	-40°C to +85°C (ISL6312AIRZ)

CAUTION: Do not operate at or near the maximum ratings listed for extended periods of time. Exposure to such conditions may adversely impact product reliability and result in failures not covered by warranty.

NOTES:

- θ_{JA} is measured in free air with the component mounted on a high effective thermal conductivity test board with "direct attach" features. See Tech Brief [TB379](#).
- For θ_{JC} , the "case temp" location is the center of the exposed metal pad on the package underside.

Electrical Specifications Recommended Operating Conditions, Unless Otherwise Specified.

PARAMETER	TEST CONDITIONS	MIN (Note 7)	TYP	MAX (Note 7)	UNITS
BIAS SUPPLIES					
Input Bias Supply Current	I _{VCC} ; EN = high	15	20	25	mA
Gate Drive Bias Current - PVCC1_2 Pin	I _{PVCC1_2} ; EN = high	2	4.3	6	mA
Gate Drive Bias Current - PVCC3 Pin	I _{PVCC3} ; EN = high	1	2.1	3	mA
VCC POR (Power-On Reset) Threshold	V _{CC} rising	4.25	4.38	4.50	V
	V _{CC} falling	3.75	3.88	4.00	V
PVCC POR (Power-On Reset) Threshold	PVCC rising	4.25	4.38	4.50	V
	PVCC falling	3.60	3.88	4.00	V
PWM MODULATOR					
Oscillator Frequency Accuracy, f _{SW}	R _T = 100kΩ (±0.1%)	225	250	275	kHz
Adjustment Range of Switching Frequency	(Note 6)	0.08	-	1.0	MHz
Oscillator Ramp Amplitude, V _{pp}	(Note 6)	-	1.50	-	V
CONTROL THRESHOLDS					
EN Rising Threshold		0.81	0.85	0.91	V
EN Hysteresis		80	110	140	mV
EN_PH4 Rising Threshold		1.160	1.210	1.250	V
EN_PH4 Falling Threshold		1.00	1.06	1.10	V
COMP Shutdown Threshold	COMP falling	0.1	0.2	0.3	V
REFERENCE AND DAC					
System Accuracy (1.000V to 1.600V)		-0.5	-	0.5	%
System Accuracy (0.600V to 1.000V)		-1.0	-	1.0	%
System Accuracy (0.375V - 0.600V)		-2.0	-	2.0	%
DAC Input Low Voltage (VR10, VR11)		-	-	0.4	V
DAC Input High Voltage (VR10, VR11)		0.8	-	-	V
DAC Input Low Voltage (AMD)		-	-	0.6	V
DAC Input High Voltage (AMD)		1.0	-	-	V

Electrical Specifications Recommended Operating Conditions, Unless Otherwise Specified. (Continued)

PARAMETER	TEST CONDITIONS	MIN (Note 7)	TYP	MAX (Note 7)	UNITS
PIN-ADJUSTABLE OFFSET					
OFS Sink Current Accuracy (Negative Offset)	$R_{OFS} = 10k\Omega$ from OFS to GND	37.0	40.0	43.0	μA
OFS Source Current Accuracy (Positive Offset)	$R_{OFS} = 30k\Omega$ from OFS to VCC	50.5	53.5	56.5	μA
ERROR AMPLIFIER					
DC Gain	$R_L = 10k$ to ground, (Note 6)	-	96	-	dB
Gain-Bandwidth Product	$C_L = 100pF$, $R_L = 10k$ to ground, (Note 6)	-	20	-	MHz
Slew Rate	$C_L = 100pF$, load = $\pm 400\mu A$, (Note 6)	-	8	-	V/ μs
Maximum Output Voltage	Load = 1mA	3.90	4.20	-	V
Minimum Output Voltage	Load = -1mA	-	1.30	1.5	V
SOFT-START RAMP					
Soft-Start Ramp Rate	VR10/VR11, $R_S = 100k\Omega$	-	1.563	-	mV/ μs
	AMD	-	2.063	-	mV/ μs
Adjustment Range of Soft-Start Ramp Rate (Note 6)		0.625	-	6.25	mV/ μs
PWM OUTPUT					
PWM Output Voltage LOW Threshold	Iload = $\pm 500\mu A$	-	-	0.5	V
PWM Output Voltage HIGH Threshold	Iload = $\pm 500\mu A$	4.5	-	-	V
CURRENT SENSING					
Current Sense Resistance, R_{ISEN}	T = +25°C	297	300	303	Ω
Sensed Current Tolerance	ISEN1+ = ISEN2+ = ISEN3+ = ISEN4+ = 80 μA	76	80	84	μA
OVERCURRENT PROTECTION					
Overcurrent Trip Level - Average Channel	Normal operation	110	125	140	μA
	Dynamic VID change	143	163	183	μA
Overcurrent Trip Level - Individual Channel	Normal operation	150	177	204	μA
	Dynamic VID change (Note 6)	209.4	238	266.6	μA
Overcurrent Protection Voltage Threshold (IOUT)	VIOUT driven to V_{OCP}	1.97	2.02	2.07	V
PROTECTION					
Undervoltage Threshold	VSEN falling	55	60	65	%VID
Undervoltage Hysteresis	VSEN rising	-	10	-	%VID
Overvoltage Threshold During Soft-Start	VR10 to VR11	1.24	1.28	1.32	V
	AMD	2.13	2.20	2.27	V
Overvoltage Threshold (Default)	VR10 to VR11, OVPSEL tied to ground, VSEN rising	VDAC + 150mV	VDAC + 175mV	VDAC + 200mV	V
	AMD, OVPSEL tied to ground, VSEN rising	VDAC + 225mV	VDAC + 250mV	VDAC + 275mV	V
Overvoltage Threshold (Alternate)	OVPSEL tied to +5V, VSEN rising	VDAC + 325mV	VDAC + 350mV	VDAC + 375mV	V
Overvoltage Hysteresis	VSEN falling	-	100	-	mV

Electrical Specifications Recommended Operating Conditions, Unless Otherwise Specified. (Continued)

PARAMETER	TEST CONDITIONS	MIN (Note 7)	TYP	MAX (Note 7)	UNITS
SWITCHING TIME (Note 6)					
UGATE Rise Time	t_{RUGATE} ; $V_{PVCC} = 12V$, 3nF load, 10% to 90%	-	26	-	ns
LGATE Rise Time	t_{RLGATE} ; $V_{PVCC} = 12V$, 3nF load, 10% to 90%	-	18	-	ns
UGATE Fall Time	t_{FUGATE} ; $V_{PVCC} = 12V$, 3nF load, 90% to 10%	-	18	-	ns
LGATE Fall Time	t_{FLGATE} ; $V_{PVCC} = 12V$, 3nF load, 90% to 10%	-	12	-	ns
UGATE Turn-On Non-Overlap	$t_{PDHUGATE}$; $V_{PVCC} = 12V$, 3nF load, adaptive	-	10	-	ns
LGATE Turn-On Non-Overlap	$t_{PDHLGATE}$; $V_{PVCC} = 12V$, 3nF load, adaptive	-	10	-	ns
GATE DRIVE RESISTANCE (Note 6)					
Upper Drive Source Resistance	$V_{PVCC} = 12V$, 15mA source current	1.25	2.0	3.0	Ω
Upper Drive Sink Resistance	$V_{PVCC} = 12V$, 15mA sink current	0.9	1.65	3.0	Ω
Lower Drive Source Resistance	$V_{PVCC} = 12V$, 15mA source current	0.85	1.25	2.2	Ω
Lower Drive Sink Resistance	$V_{PVCC} = 12V$, 15mA sink current	0.60	0.80	1.35	Ω
OVER-TEMPERATURE SHUTDOWN (Note 6)					
Thermal Shutdown Setpoint		-	160	-	$^{\circ}C$
Thermal Recovery Setpoint		-	100	-	$^{\circ}C$

NOTES:

- Limits established by characterization and are not production tested.
- Parameters with MIN and/or MAX limits are 100% tested at +25 $^{\circ}C$, unless otherwise specified. Temperature limits established by characterization and are not production tested.

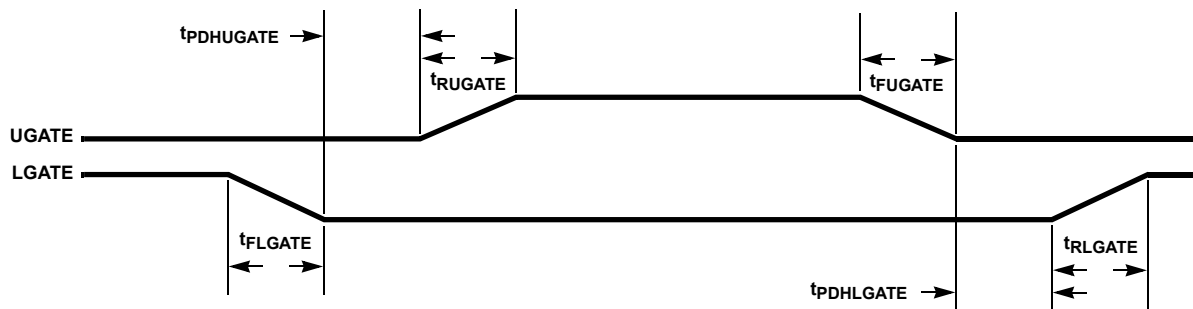
Timing Diagram

Functional Pin Description

VCC

VCC is the bias supply for the ICs small-signal circuitry. Connect this pin to a +5V supply and decouple using a quality 0.1 μ F ceramic capacitor.

PVCC1_2 and PVCC3

These pins are the power supply pins for the corresponding channel MOSFET drive, and can be connected to any voltage from +5V to +12V depending on the desired MOSFET gate-drive level. Decouple these pins with a quality 1.0 μ F ceramic capacitor.

Leaving PVCC3 unconnected or grounded programs the controller for 2-phase operation.

GND

GND is the bias and reference ground for the IC.

EN

This pin is a threshold-sensitive (approximately 0.85V) enable input for the controller. Held low, this pin disables controller operation. Pulled high, the pin enables the controller for operation.

FS

A resistor, placed from FS to ground, sets the switching frequency of the controller.

VID0, VID1, VID2, VID3, VID4, VID5, VID6, and VID7

These are the inputs for the internal DAC that provides the reference voltage for output regulation. These pins respond to TTL logic thresholds. These pins are internally pulled high, to approximately 1.2V, by 40 μ A internal current sources for Intel modes of operation, and pulled low by 20 μ A internal current sources for AMD modes of operation. The internal pull-up current decreases to 0 as the VID voltage approaches the internal pull-up voltage. All VID pins are compatible with external pull-up voltages not exceeding the IC's bias voltage (VCC).

VRSEL

The state of this pin selects which of the available DAC tables will be used to decode the VID inputs and puts the controller into the corresponding mode of operation. Refer to [Table 1](#) for available options and details of implementation.

VSEN and RGND

VSEN and RGND are inputs to the precision differential remote-sense amplifier and should be connected to the sense pins of the remote load.

VDIFF

VDIFF is the output of the differential remote-sense amplifier. The voltage on this pin is equal to the difference between VSEN and RGND.

FB and COMP

These pins are the internal error amplifier inverting input and output respectively. FB, VDIFF, and COMP are tied together through external R-C networks to compensate the regulator.

IOUT

The IOUT pin is the average channel-current sense output. Connecting this pin through a resistor to ground allows the controller to set the overcurrent protection trip level. This pin pin can also be used as a load current indicator to monitor what the output load current is.

REF

The REF input pin is the positive input of the error amplifier. It is internally connected to the DAC output through a 1k Ω resistor. A capacitor is used between the REF pin and ground to smooth the voltage transition during Dynamic VID operations.

OFS

The OFS pin provides a means to program a DC current for generating an offset voltage across the resistor between FB and VDIFF. The offset current is generated via an external resistor and precision internal voltage references. The polarity of the offset is selected by connecting the resistor to GND or VCC. For no offset, the OFS pin should be left unconnected.

ISEN1-, ISEN1+, ISEN2-, ISEN2+, ISEN3-, ISEN3+, ISEN4- and ISEN4+

These pins are used for differentially sensing the corresponding channel output currents. The sensed currents are used for channel balancing, protection, and load-line regulation.

Connect ISEN1-, ISEN2-, ISEN3-, and ISEN4- to the node between the RC sense elements surrounding the inductor of their respective channel. Tie the ISEN+ pins to the VCORE side of their corresponding channel's sense capacitor.

UGATE1, UGATE2, and UGATE3

Connect these pins to the corresponding upper MOSFET gates. These pins are used to control the upper MOSFETs and are monitored for shoot-through prevention purposes.

BOOT1, BOOT2 and BOOT3

These pins provide the bias voltage for the corresponding upper MOSFET drives. Connect these pins to appropriately-chosen external bootstrap capacitors. Internal bootstrap diodes connected to the PVCC pins provide the necessary bootstrap charge.

PHASE1, PHASE2 and PHASE3

Connect these pins to the sources of the corresponding upper MOSFETs. These pins are the return path for the upper MOSFET drives.

LGATE1, LGATE2 and LGATE3

These pins are used to control the lower MOSFETs. Connect these pins to the corresponding lower MOSFETs' gates.

PWM4

Pulse-width modulation output. Connect this pin to the PWM input pin of an Intersil driver IC if 4-phase operation is desired.

EN_PH4

This pin has two functions. First, a resistor divider connected to this pin will provide a POR power up synch between the on-chip and external driver. The resistor divider should be designed so that when the POR-trip point of the external driver is reached the voltage on this pin should be 1.21V.

The second function of this pin is disabling PWM4 for 3-phase operation. This can be accomplished by connecting this pin to a +5V supply.

SS

A resistor, placed from SS to ground, will set the soft-start ramp slope for the Intel DAC modes of operation. Refer to [Equations 18](#) and [19](#) for proper resistor calculation.

For AMD modes of operation, the soft-start ramp frequency is preset, so this pin can be left unconnected.

OVPSEL

This pin selects the OVP trip point during normal operation. Leaving it unconnected or tying it to ground selects the default setting of VDAC+175mV for Intel Modes of operation and VDAC+250mV for AMD modes of operation. Connecting this pin to VCC will select an OVP trip setting of VID+350mV for all modes of operation.

DRSEL

This pin selects the adaptive deadtime scheme the internal drivers will use. If driving MOSFETs, tie this pin to ground to select the PHASE detect scheme or to a +5V supply through a 50kΩ resistor to select the LGATE detect scheme.

PGOOD

During normal operation PGOOD indicates whether the output voltage is within specified overvoltage and undervoltage limits. If the output voltage exceeds these limits or a reset event occurs (such as an overcurrent event), PGOOD is pulled low. PGOOD is always low prior to the end of soft-start.

Operation

Multiphase Power Conversion

Microprocessor load current profiles have changed to the point that using single-phase regulators is no longer a viable solution. Designing a regulator that is cost-effective, thermally sound, and efficient has become a challenge that only multiphase converters can accomplish. The ISL6312A controller helps simplify implementation by integrating vital functions and requiring minimal external components. The “Block Diagram” on page 4 provides a top level view of multiphase power conversion using the ISL6312A controller.

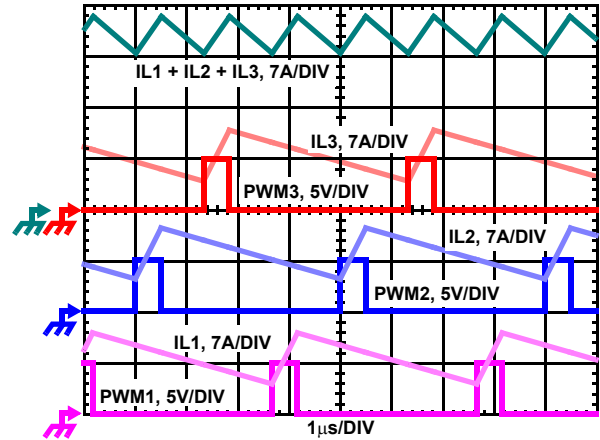

FIGURE 1. PWM AND INDUCTOR-CURRENT WAVEFORMS FOR 3-PHASE CONVERTER

Interleaving

The switching of each channel in a multiphase converter is timed to be symmetrically out of phase with each of the other channels. In a 3-phase converter, each channel switches 1/3 cycle after the previous channel and 1/3 cycle before the following channel. As a result, the three-phase converter has a combined ripple frequency three times greater than the ripple frequency of any one phase. In addition, the peak-to-peak amplitude of the combined inductor currents is reduced in proportion to the number of phases ([Equations 1](#) and [2](#)). Increased ripple frequency and lower ripple amplitude mean that the designer can use less per-channel inductance and lower total output capacitance for any performance specification.

[Figure 1](#) illustrates the multiplicative effect on output ripple frequency. The three channel currents (IL1, IL2, and IL3) combine to form the AC ripple current and the DC load current. The ripple component has three times the ripple frequency of each individual channel current. Each PWM pulse is terminated 1/3 of a cycle after the PWM pulse of the previous phase. The peak-to-peak current for each phase is about 7A, and the DC components of the inductor currents combine to feed the load.

To understand the reduction of ripple current amplitude in the multiphase circuit, examine the equation representing an individual channel peak-to-peak inductor current.

$$I_{(P-P)} = \frac{(V_{IN} - V_{OUT}) \cdot V_{OUT}}{L \cdot f_S \cdot V_{IN}} \quad (\text{EQ. 1})$$

In [Equation 1](#), V_{IN} and V_{OUT} are the input and output voltages respectively, L is the single-channel inductor value, and f_S is the switching frequency.

The output capacitors conduct the ripple component of the inductor current. In the case of multiphase converters, the capacitor current is the sum of the ripple currents from each of the individual channels. Compare [Equation 1](#) to the expression for the peak-to-peak current after the summation

of N symmetrically phase-shifted inductor currents in Equation 2. Peak-to-peak ripple current decreases by an amount proportional to the number of channels. Output voltage ripple is a function of capacitance, capacitor equivalent series resistance (ESR), and inductor ripple current. Reducing the inductor ripple current allows the designer to use fewer or less costly output capacitors.

$$I_{C,(P-P)} = \frac{(V_{IN} - N \cdot V_{OUT}) \cdot V_{OUT}}{L \cdot f_S \cdot V_{IN}} \quad (\text{EQ. 2})$$

Another benefit of interleaving is to reduce input ripple current. Input capacitance is determined in part by the maximum input ripple current. Multiphase topologies can improve overall system cost and size by lowering input ripple current and allowing the designer to reduce the cost of input capacitance. The example in Figure 2 illustrates input currents from a three-phase converter combining to reduce the total input ripple current.

The converter depicted in Figure 2 delivers 1.5V to a 36A load from a 12V input. The RMS input capacitor current is 5.9A. Compare this to a single-phase converter also stepping down 12V to 1.5V at 36A. The single-phase converter has 11.9A RMS input capacitor current. The single-phase converter must use an input capacitor bank with twice the RMS current capacity as the equivalent three-phase converter.

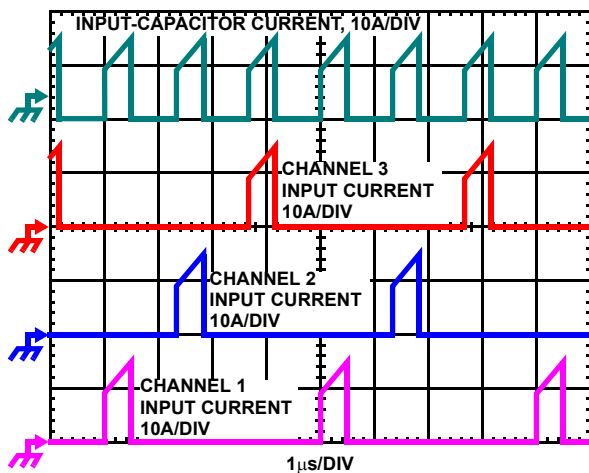

FIGURE 2. CHANNEL INPUT CURRENTS AND INPUT-CAPACITOR RMS CURRENT FOR 3-PHASE CONVERTER

Active Pulse Positioning (APP) Modulated PWM Operation

The ISL6312A uses a proprietary Active Pulse Positioning (APP) modulation scheme to control the internal PWM signals that command each channel's driver to turn their upper and lower MOSFETs on and off. The time interval in which a PWM signal can occur is generated by an internal clock, whose cycle time is the inverse of the switching frequency set by the resistor between the FS pin and ground. The advantage of Intersil's proprietary Active Pulse Positioning (APP) modulator is that the PWM signal has the ability to turn on at any point during this PWM time interval, and turn off immediately after the PWM signal has

transitioned high. This is important because it allows the controller to quickly respond to output voltage drops associated with current load spikes, while avoiding the ring back effects associated with other modulation schemes.

The PWM output state is driven by the position of the error amplifier output signal, V_{COMP} , minus the current correction signal relative to the proprietary modulator ramp waveform as illustrated in Figure 3. At the beginning of each PWM time interval, this modified V_{COMP} signal is compared to the internal modulator waveform. As long as the modified V_{COMP} voltage is lower than the modulator waveform voltage, the PWM signal is commanded low. The internal MOSFET driver detects the low state of the PWM signal and turns off the upper MOSFET and turns on the lower synchronous MOSFET. When the modified V_{COMP} voltage crosses the modulator ramp, the PWM output transitions high, turning off the synchronous MOSFET and turning on the upper MOSFET. The PWM signal will remain high until the modified V_{COMP} voltage crosses the modulator ramp again. When this occurs the PWM signal will transition low again.

During each PWM time interval the PWM signal can only transition high once. Once PWM transitions high it can not transition high again until the beginning of the next PWM time interval. This prevents the occurrence of double PWM pulses occurring during a single period.

To further improve the transient response, the ISL6312A also implements Intersil's proprietary Adaptive Phase Alignment (APA) technique, which turns on all phases together under transient events with large step current. With both APP and APA control, the ISL6312A can achieve excellent transient performance and reduce the demand on the output capacitors.

Channel-Current Balance

One important benefit of multiphase operation is the thermal advantage gained by distributing the dissipated heat over multiple devices and greater area. By doing this the designer avoids the complexity of driving parallel MOSFETs and the expense of using expensive heat sinks and exotic magnetic materials.

In order to realize the thermal advantage, it is important that each channel in a multiphase converter be controlled to carry equal amounts of current at any load level. To achieve this, the currents through each channel must be sampled every switching cycle. The sampled currents, I_n , from each active channel are summed together and divided by the number of active channels. The resulting cycle average current, I_{AVG} , provides a measure of the total load-current demand on the converter during each switching cycle. Channel-current balance is achieved by comparing the sampled current of each channel to the cycle average current, and making the proper adjustment to each channel pulse width based on the error. Intersil's patented current

balance method is illustrated in [Figure 3](#), with error correction for Channel 1 represented. The cycle average current, I_{AVG} , is compared with the Channel 1 sample, I_1 , to create an error signal I_{ER} (see [Figure 3](#)).

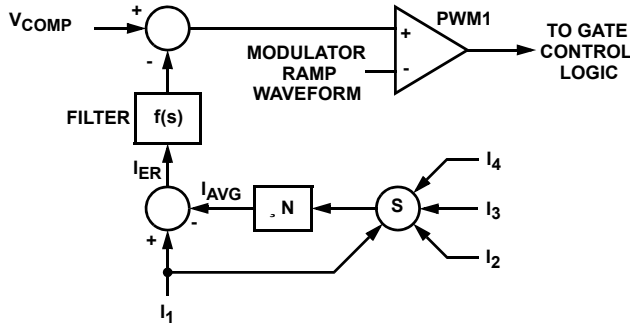

NOTE: Channel 3 and 4 are optional.

FIGURE 3. CHANNEL-1 PWM FUNCTION AND CURRENT BALANCE ADJUSTMENT

The filtered error signal modifies the pulse width commanded by V_{COMP} to correct any unbalance and force I_{ER} toward zero. The same method for error signal correction is applied to each active channel.

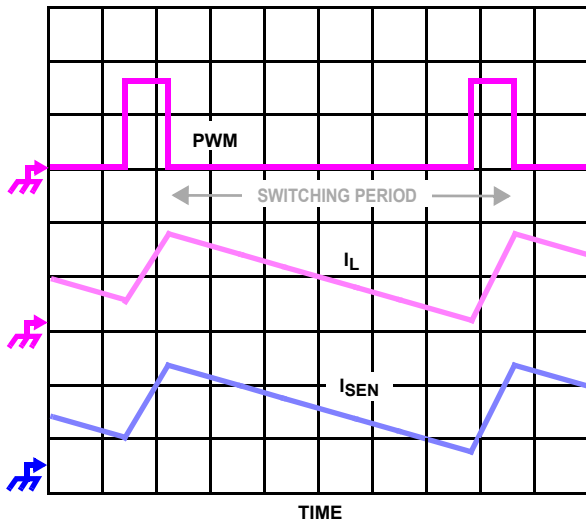

FIGURE 4. CONTINUOUS CURRENT SAMPLING

Continuous Current Sampling

In order to realize proper current balance, the currents in each channel are sensed continuously every switching cycle. During this time the current sense amplifier uses the ISEN inputs to reproduce a signal proportional to the inductor current, I_L . This sensed current, I_{SEN} , is simply a scaled version of the inductor current.

The ISL6312A supports inductor DCR current sensing to continuously sense each channel’s current for channel current balance. The internal circuitry, shown in [Figure 5](#) represents Channel N of an N-channel converter. This circuitry is repeated for each channel in the converter, but may not be active depending on how many channels are operating.

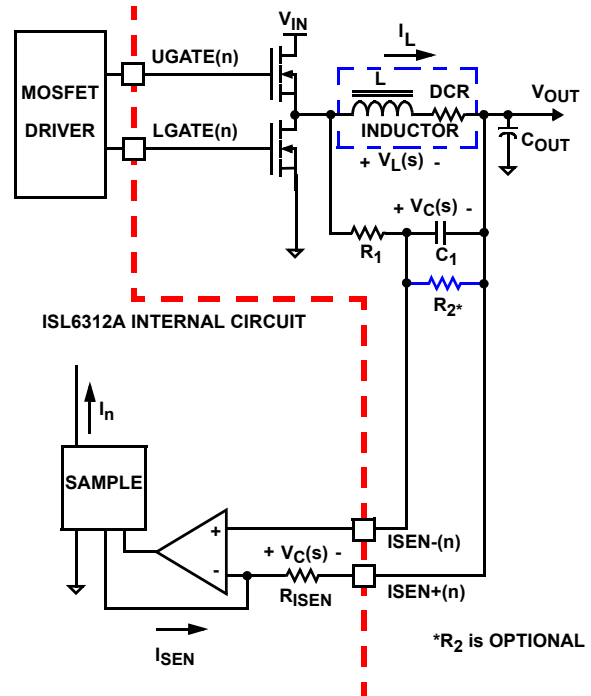

FIGURE 5. INDUCTOR DCR CURRENT SENSING CONFIGURATION

Inductor windings have a characteristic distributed resistance or DCR (Direct Current Resistance). For simplicity, the inductor DCR is considered as a separate lumped quantity, as shown in [Figure 5](#). The channel current I_L , flowing through the inductor, passes through the DCR. [Equation 3](#) shows the s-domain equivalent voltage, V_L , across the inductor.

$$V_L(s) = I_L \cdot (s \cdot L + DCR) \tag{EQ. 3}$$

A simple R-C network across the inductor (R_1 and C) extracts the DCR voltage, as shown in [Figure 5](#). The voltage across the sense capacitor, V_C , can be shown to be proportional to the channel current I_L , shown in [Equation 4](#).

$$V_C(s) = \frac{(s \cdot L + 1)}{(s \cdot R_1 \cdot C + 1)} \cdot DCR \cdot I_L \tag{EQ. 4}$$

In some cases it may be necessary to use a resistor divider R-C network to sense the current through the inductor. This can be accomplished by placing a second resistor, R_2 , across the sense capacitor. In these cases the voltage across the sense capacitor, V_C , becomes proportional to the channel current I_L , and the resistor divider ratio, K .

$$V_C(s) = \frac{\left(\frac{s \cdot L}{DCR} + 1\right)}{\left(s \cdot \frac{(R_1 \cdot R_2)}{R_1 + R_2} \cdot C + 1\right)} \cdot K \cdot DCR \cdot I_L \quad (\text{EQ. 5})$$

$$K = \frac{R_2}{R_2 + R_1} \quad (\text{EQ. 6})$$

If the R-C network components are selected such that the RC time constant matches the inductor L/DCR time constant, then V_C is equal to the voltage drop across the DCR multiplied by the ratio of the resistor divider, K. If a resistor divider is not being used, the value for K is 1.

The capacitor voltage V_C , is then replicated across the sense resistor R_{ISEN} . The current through R_{ISEN} is proportional to the inductor current. [Equation 7](#) shows that the proportion between the channel current and the sensed current (I_{SEN}) is driven by the value of the sense resistor, the resistor divider ratio, and the DCR of the inductor.

$$I_{SEN} = K \cdot I_L \cdot \frac{DCR}{R_{ISEN}} \quad (\text{EQ. 7})$$

Output Voltage Setting

The ISL6312A uses a digital to analog converter (DAC) to generate a reference voltage based on the logic signals at the VID pins. The DAC decodes the logic signals into one of the discrete voltages shown in [Tables 2, 3, 4](#) and [5](#). In Intel modes of operation, each VID pin is pulled up to an internal 1.2V voltage by a weak current source (40 μ A), which decreases to 0A as the voltage at the VID pin varies from 0 to the internal 1.2V pull-up voltage. In AMD modes of operation the VID pins are pulled low by a weak 20 μ A current source. External pull-up resistors or active-high output stages can augment the pull-up current sources, up to a voltage of 5V.

The ISL6312A accommodates four different DAC ranges: Intel VR10 (Extended), Intel VR11, AMD K8/K9 5-bit, and AMD 6-bit. The state of the VRSEL and VID7 pins decide which DAC version is active. Refer to [Table 1](#) for a description of how to select the desired DAC version. For VR11 setting, tie the VRSEL pin to the midpoint of a 10k Ω (or other suitable value) resistor divider connected from VCC to GND.

TABLE 1. ISL6312A DAC SELECT TABLE

DAC VERSION	VRSEL PIN	VID7 PIN
VR10(Extended)	VRSEL = GND	-
VR11	VRSEL = VCC/2	-
AMD 5-Bit	VRSEL = VCC	LOW
AMD 6-Bit	VRSEL = VCC	HIGH

TABLE 2. VR10 (EXTENDED) VOLTAGE IDENTIFICATION CODES

VID4	VID3	VID2	VID1	VID0	VID5	VID6	VDAC
0	1	0	1	0	1	1	1.60000
0	1	0	1	0	1	0	1.59375
0	1	0	1	1	0	1	1.58750
0	1	0	1	1	0	0	1.58125
0	1	0	1	1	1	1	1.57500
0	1	0	1	1	1	0	1.56875
0	1	1	0	0	0	1	1.56250
0	1	1	0	0	0	0	1.55625
0	1	1	0	0	1	1	1.55000
0	1	1	0	0	1	0	1.54375
0	1	1	0	1	0	1	1.53750
0	1	1	0	1	0	0	1.53125
0	1	1	0	1	1	1	1.52500
0	1	1	0	1	1	0	1.51875
0	1	1	1	0	0	1	1.51250
0	1	1	1	0	0	0	1.50625
0	1	1	1	0	1	1	1.50000
0	1	1	1	0	1	0	1.49375
0	1	1	1	1	0	1	1.48750
0	1	1	1	1	0	0	1.48125
0	1	1	1	1	1	1	1.47500
0	1	1	1	1	1	0	1.46875
1	0	0	0	0	0	1	1.46250
1	0	0	0	0	0	0	1.45625
1	0	0	0	0	1	1	1.45000
1	0	0	0	0	1	0	1.44375
1	0	0	0	1	0	1	1.43750
1	0	0	0	1	0	0	1.43125
1	0	0	0	1	1	1	1.42500
1	0	0	0	1	1	0	1.41875
1	0	0	1	0	0	1	1.41250
1	0	0	1	0	0	0	1.40625
1	0	0	1	0	1	1	1.40000
1	0	0	1	0	1	0	1.39375
1	0	0	1	1	0	1	1.38750
1	0	0	1	1	0	0	1.38125
1	0	0	1	1	1	1	1.37500
1	0	0	1	1	1	0	1.36875
1	0	1	0	0	0	1	1.36250

TABLE 2. VR10 (EXTENDED) VOLTAGE IDENTIFICATION CODES (Continued)

VID4	VID3	VID2	VID1	VID0	VID5	VID6	VDAC
1	0	1	0	0	0	0	1.35625
1	0	1	0	0	1	1	1.35000
1	0	1	0	0	1	0	1.34375
1	0	1	0	1	0	1	1.33750
1	0	1	0	1	0	0	1.33125
1	0	1	0	1	1	1	1.32500
1	0	1	0	1	1	0	1.31875
1	0	1	1	0	0	1	1.31250
1	0	1	1	0	0	0	1.30625
1	0	1	1	0	1	1	1.30000
1	0	1	1	0	1	0	1.29375
1	0	1	1	1	0	1	1.28750
1	0	1	1	1	0	0	1.28125
1	0	1	1	1	1	1	1.27500
1	0	1	1	1	1	0	1.26875
1	1	0	0	0	0	1	1.26250
1	1	0	0	0	0	0	1.25625
1	1	0	0	0	1	1	1.25000
1	1	0	0	0	1	0	1.24375
1	1	0	0	1	0	1	1.23750
1	1	0	0	1	0	0	1.23125
1	1	0	0	1	1	1	1.22500
1	1	0	0	1	1	0	1.21875
1	1	0	1	0	0	1	1.21250
1	1	0	1	0	0	0	1.20625
1	1	0	1	0	1	1	1.20000
1	1	0	1	0	1	0	1.19375
1	1	0	1	1	0	1	1.18750
1	1	0	1	1	0	0	1.18125
1	1	0	1	1	1	1	1.17500
1	1	0	1	1	1	0	1.16875
1	1	1	0	0	0	1	1.16250
1	1	1	0	0	0	0	1.15625
1	1	1	0	0	1	1	1.15000
1	1	1	0	0	1	0	1.14375
1	1	1	0	1	0	1	1.13750
1	1	1	0	1	0	0	1.13125
1	1	1	0	1	1	1	1.12500
1	1	1	0	1	1	0	1.11875

TABLE 2. VR10 (EXTENDED) VOLTAGE IDENTIFICATION CODES (Continued)

VID4	VID3	VID2	VID1	VID0	VID5	VID6	VDAC
1	1	1	1	0	0	1	1.11250
1	1	1	1	0	0	0	1.10625
1	1	1	1	0	1	1	1.10000
1	1	1	1	0	1	0	1.09375
1	1	1	1	1	0	1	OFF
1	1	1	1	1	0	0	OFF
1	1	1	1	1	1	1	OFF
1	1	1	1	1	1	0	OFF
0	0	0	0	0	0	1	1.08750
0	0	0	0	0	0	0	1.08125
0	0	0	0	0	1	1	1.07500
0	0	0	0	0	1	0	1.06875
0	0	0	0	1	0	1	1.06250
0	0	0	0	1	0	0	1.05625
0	0	0	0	1	1	1	1.05000
0	0	0	0	1	1	0	1.04375
0	0	0	1	0	0	1	1.03750
0	0	0	1	0	0	0	1.03125
0	0	0	1	0	1	1	1.02500
0	0	0	1	0	1	0	1.01875
0	0	0	1	1	0	1	1.01250
0	0	0	1	1	0	0	1.00625
0	0	0	1	1	1	1	1.00000
0	0	0	1	1	1	0	0.99375
0	0	1	0	0	0	1	0.98750
0	0	1	0	0	0	0	0.98125
0	0	1	0	0	1	1	0.97500
0	0	1	0	0	1	0	0.96875
0	0	1	0	1	0	1	0.96250
0	0	1	0	1	0	0	0.95625
0	0	1	0	1	1	1	0.95000
0	0	1	0	1	1	0	0.94375
0	0	1	1	0	0	1	0.93750
0	0	1	1	0	0	0	0.93125
0	0	1	1	0	1	1	0.92500
0	0	1	1	0	1	0	0.91875
0	0	1	1	1	0	1	0.91250
0	0	1	1	1	0	0	0.90625
0	0	1	1	1	1	1	0.90000

TABLE 2. VR10 (EXTENDED) VOLTAGE IDENTIFICATION CODES (Continued)

VID4	VID3	VID2	VID1	VID0	VID5	VID6	VDAC
0	0	1	1	1	1	0	0.89375
0	1	0	0	0	0	1	0.88750
0	1	0	0	0	0	0	0.88125
0	1	0	0	0	1	1	0.87500
0	1	0	0	0	1	0	0.86875
0	1	0	0	1	0	1	0.86250
0	1	0	0	1	0	0	0.85625
0	1	0	0	1	1	1	0.85000
0	1	0	0	1	1	0	0.84375
0	1	0	1	0	0	1	0.83750
0	1	0	1	0	0	0	0.83125

TABLE 3. VR11 VOLTAGE IDENTIFICATION CODES

VID7	VID6	VID5	VID4	VID3	VID2	VID1	VID0	VDAC
0	0	0	0	0	0	0	0	OFF
0	0	0	0	0	0	0	1	OFF
0	0	0	0	0	0	1	0	1.60000
0	0	0	0	0	0	1	1	1.59375
0	0	0	0	0	1	0	0	1.58750
0	0	0	0	0	1	0	1	1.58125
0	0	0	0	0	1	1	0	1.57500
0	0	0	0	0	1	1	1	1.56875
0	0	0	0	1	0	0	0	1.56250
0	0	0	0	1	0	0	1	1.55625
0	0	0	0	1	0	1	0	1.55000
0	0	0	0	1	0	1	1	1.54375
0	0	0	0	1	1	0	0	1.53750
0	0	0	0	1	1	0	1	1.53125
0	0	0	0	1	1	1	0	1.52500
0	0	0	0	1	1	1	1	1.51875
0	0	0	1	0	0	0	0	1.51250
0	0	0	1	0	0	0	1	1.50625
0	0	0	1	0	0	1	0	1.50000
0	0	0	1	0	0	1	1	1.49375
0	0	0	1	0	1	0	0	1.48750
0	0	0	1	0	1	0	1	1.48125
0	0	0	1	0	1	1	0	1.47500
0	0	0	1	0	1	1	1	1.46875
0	0	0	1	1	0	0	0	1.46250

TABLE 3. VR11 VOLTAGE IDENTIFICATION CODES (Continued)

VID7	VID6	VID5	VID4	VID3	VID2	VID1	VID0	VDAC
0	0	0	1	1	0	0	1	1.45625
0	0	0	1	1	0	1	0	1.45000
0	0	0	1	1	0	1	1	1.44375
0	0	0	1	1	1	0	0	1.43750
0	0	0	1	1	1	0	1	1.43125
0	0	0	1	1	1	1	0	1.42500
0	0	0	1	1	1	1	1	1.41875
0	0	1	0	0	0	0	0	1.41250
0	0	1	0	0	0	0	1	1.40625
0	0	1	0	0	0	1	0	1.40000
0	0	1	0	0	0	1	1	1.39375
0	0	1	0	0	1	0	0	1.38750
0	0	1	0	0	1	0	1	1.38125
0	0	1	0	0	1	1	0	1.37500
0	0	1	0	0	1	1	1	1.36875
0	0	1	0	1	0	0	0	1.36250
0	0	1	0	1	0	0	1	1.35625
0	0	1	0	1	0	1	0	1.35000
0	0	1	0	1	0	1	1	1.34375
0	0	1	0	1	1	0	0	1.33750
0	0	1	0	1	1	0	1	1.33125
0	0	1	0	1	1	1	0	1.32500
0	0	1	0	1	1	1	1	1.31875
0	0	1	1	0	0	0	0	1.31250
0	0	1	1	0	0	0	1	1.30625
0	0	1	1	0	0	1	0	1.30000
0	0	1	1	0	0	1	1	1.29375
0	0	1	1	0	1	0	0	1.28750
0	0	1	1	0	1	0	1	1.28125
0	0	1	1	0	1	1	0	1.27500
0	0	1	1	0	1	1	1	1.26875
0	0	1	1	1	0	0	0	1.26250
0	0	1	1	1	0	0	1	1.25625
0	0	1	1	1	0	1	0	1.25000
0	0	1	1	1	0	1	1	1.24375
0	0	1	1	1	1	0	0	1.23750
0	0	1	1	1	1	0	1	1.23125
0	0	1	1	1	1	1	0	1.22500
0	0	1	1	1	1	1	1	1.21875

**TABLE 3. VR11 VOLTAGE IDENTIFICATION
CODES (Continued)**

VID7	VID6	VID5	VID4	VID3	VID2	VID1	VID0	VDAC
0	1	0	0	0	0	0	0	1.21250
0	1	0	0	0	0	0	1	1.20625
0	1	0	0	0	0	1	0	1.20000
0	1	0	0	0	0	1	1	1.19375
0	1	0	0	0	1	0	0	1.18750
0	1	0	0	0	1	0	1	1.18125
0	1	0	0	0	1	1	0	1.17500
0	1	0	0	0	1	1	1	1.16875
0	1	0	0	1	0	0	0	1.16250
0	1	0	0	1	0	0	1	1.15625
0	1	0	0	1	0	1	0	1.15000
0	1	0	0	1	0	1	1	1.14375
0	1	0	0	1	1	0	0	1.13750
0	1	0	0	1	1	0	1	1.13125
0	1	0	0	1	1	1	0	1.12500
0	1	0	0	1	1	1	1	1.11875
0	1	0	1	0	0	0	0	1.11250
0	1	0	1	0	0	0	1	1.10625
0	1	0	1	0	0	1	0	1.10000
0	1	0	1	0	0	1	1	1.09375
0	1	0	1	0	1	0	0	1.08750
0	1	0	1	0	1	0	1	1.08125
0	1	0	1	0	1	1	0	1.07500
0	1	0	1	0	1	1	1	1.06875
0	1	0	1	1	0	0	0	1.06250
0	1	0	1	1	0	0	1	1.05625
0	1	0	1	1	0	1	0	1.05000
0	1	0	1	1	0	1	1	1.04375
0	1	0	1	1	1	0	0	1.03750
0	1	0	1	1	1	0	1	1.03125
0	1	0	1	1	1	1	0	1.02500
0	1	0	1	1	1	1	1	1.01875
0	1	1	0	0	0	0	0	1.01250
0	1	1	0	0	0	0	1	1.00625
0	1	1	0	0	0	1	0	1.00000
0	1	1	0	0	0	1	1	0.99375
0	1	1	0	0	1	0	0	0.98750
0	1	1	0	0	1	0	1	0.98125
0	1	1	0	0	1	1	0	0.97500

**TABLE 3. VR11 VOLTAGE IDENTIFICATION
CODES (Continued)**

VID7	VID6	VID5	VID4	VID3	VID2	VID1	VID0	VDAC
0	1	1	0	0	1	1	1	0.96875
0	1	1	0	1	0	0	0	0.96250
0	1	1	0	1	0	0	1	0.95625
0	1	1	0	1	0	1	0	0.95000
0	1	1	0	1	0	1	1	0.94375
0	1	1	0	1	1	0	0	0.93750
0	1	1	0	1	1	0	1	0.93125
0	1	1	0	1	1	1	0	0.92500
0	1	1	0	1	1	1	1	0.91875
0	1	1	1	0	0	0	0	0.91250
0	1	1	1	0	0	0	1	0.90625
0	1	1	1	0	0	1	0	0.90000
0	1	1	1	0	0	1	1	0.89375
0	1	1	1	0	1	0	0	0.88750
0	1	1	1	0	1	0	1	0.88125
0	1	1	1	0	1	1	0	0.87500
0	1	1	1	0	1	1	1	0.86875
0	1	1	1	1	0	0	0	0.86250
0	1	1	1	1	0	0	1	0.85625
0	1	1	1	1	0	1	0	0.85000
0	1	1	1	1	0	1	1	0.84375
0	1	1	1	1	1	0	0	0.83750
0	1	1	1	1	1	0	1	0.83125
0	1	1	1	1	1	1	0	0.82500
0	1	1	1	1	1	1	1	0.81875
1	0	0	0	0	0	0	0	0.81250
1	0	0	0	0	0	0	1	0.80625
1	0	0	0	0	0	1	0	0.80000
1	0	0	0	0	0	1	1	0.79375
1	0	0	0	0	1	0	0	0.78750
1	0	0	0	0	1	0	1	0.78125
1	0	0	0	0	1	1	0	0.77500
1	0	0	0	0	1	1	1	0.76875
1	0	0	0	1	0	0	0	0.76250
1	0	0	0	1	0	0	1	0.75625
1	0	0	0	1	0	1	0	0.75000
1	0	0	0	1	0	1	1	0.74375
1	0	0	0	1	1	0	0	0.73750
1	0	0	0	1	1	0	1	0.73125

TABLE 3. VR11 VOLTAGE IDENTIFICATION CODES (Continued)

VID7	VID6	VID5	VID4	VID3	VID2	VID1	VID0	VDAC
1	0	0	0	1	1	1	0	0.72500
1	0	0	0	1	1	1	1	0.71875
1	0	0	1	0	0	0	0	0.71250
1	0	0	1	0	0	0	1	0.70625
1	0	0	1	0	0	1	0	0.70000
1	0	0	1	0	0	1	1	0.69375
1	0	0	1	0	1	0	0	0.68750
1	0	0	1	0	1	0	1	0.68125
1	0	0	1	0	1	1	0	0.67500
1	0	0	1	0	1	1	1	0.66875
1	0	0	1	1	0	0	0	0.66250
1	0	0	1	1	0	0	1	0.65625
1	0	0	1	1	0	1	0	0.65000
1	0	0	1	1	0	1	1	0.64375
1	0	0	1	1	1	0	0	0.63750
1	0	0	1	1	1	0	1	0.63125
1	0	0	1	1	1	1	0	0.62500
1	0	0	1	1	1	1	1	0.61875
1	0	1	0	0	0	0	0	0.61250
1	0	1	0	0	0	0	1	0.60625
1	0	1	0	0	0	1	0	0.60000
1	0	1	0	0	0	1	1	0.59375
1	0	1	0	0	1	0	0	0.58750
1	0	1	0	0	1	0	1	0.58125
1	0	1	0	0	1	1	0	0.57500
1	0	1	0	0	1	1	1	0.56875
1	0	1	0	1	0	0	0	0.56250
1	0	1	0	1	0	0	1	0.55625
1	0	1	0	1	0	1	0	0.55000
1	0	1	0	1	0	1	1	0.54375
1	0	1	0	1	1	0	0	0.53750
1	0	1	0	1	1	0	1	0.53125
1	0	1	0	1	1	1	0	0.52500
1	0	1	0	1	1	1	1	0.51875
1	0	1	1	0	0	0	0	0.51250
1	0	1	1	0	0	0	1	0.50625
1	0	1	1	0	0	1	0	0.50000
1	1	1	1	1	1	1	0	OFF
1	1	1	1	1	1	1	1	OFF

TABLE 4. AMD 5-BIT VOLTAGE IDENTIFICATION CODES

VID4	VID3	VID2	VID1	VID0	VDAC
1	1	1	1	1	Off
1	1	1	1	0	0.800
1	1	1	0	1	0.825
1	1	1	0	0	0.850
1	1	0	1	1	0.875
1	1	0	1	0	0.900
1	1	0	0	1	0.925
1	1	0	0	0	0.950
1	0	1	1	1	0.975
1	0	1	1	0	1.000
1	0	1	0	1	1.025
1	0	1	0	0	1.050
1	0	0	1	1	1.075
1	0	0	1	0	1.100
1	0	0	0	1	1.125
1	0	0	0	0	1.150
0	1	1	1	1	1.175
0	1	1	1	0	1.200
0	1	1	0	1	1.225
0	1	1	0	0	1.250
0	1	0	1	1	1.275
0	1	0	1	0	1.300
0	1	0	0	1	1.325
0	1	0	0	0	1.350
0	0	1	1	1	1.375
0	0	1	1	0	1.400
0	0	1	0	1	1.425
0	0	1	0	0	1.450
0	0	0	1	1	1.475
0	0	0	1	0	1.500
0	0	0	0	1	1.525
0	0	0	0	0	1.550

TABLE 5. AMD 6-BIT VOLTAGE IDENTIFICATION CODES

VID5	VID4	VID3	VID2	VID1	VID0	VDAC
0	0	0	0	0	0	1.5500
0	0	0	0	0	1	1.5250
0	0	0	0	1	0	1.5000
0	0	0	0	1	1	1.4750
0	0	0	1	0	0	1.4500
0	0	0	1	0	1	1.4250
0	0	0	1	1	0	1.4000
0	0	0	1	1	1	1.3750
0	0	1	0	0	0	1.3500
0	0	1	0	0	1	1.3250
0	0	1	0	1	0	1.3000
0	0	1	0	1	1	1.2750
0	0	1	1	0	0	1.2500
0	0	1	1	0	1	1.2250
0	0	1	1	1	0	1.2000
0	0	1	1	1	1	1.1750
0	1	0	0	0	0	1.1500
0	1	0	0	0	1	1.1250
0	1	0	0	1	0	1.1000
0	1	0	0	1	1	1.0750
0	1	0	1	0	0	1.0500
0	1	0	1	0	1	1.0250
0	1	0	1	1	0	1.0000
0	1	0	1	1	1	0.9750
0	1	1	0	0	0	0.9500
0	1	1	0	0	1	0.9250
0	1	1	0	1	0	0.9000
0	1	1	0	1	1	0.8750
0	1	1	1	0	0	0.8500
0	1	1	1	0	1	0.8250
0	1	1	1	1	0	0.8000
0	1	1	1	1	1	0.7750
1	0	0	0	0	0	0.7625
1	0	0	0	0	1	0.7500
1	0	0	0	1	0	0.7375
1	0	0	0	1	1	0.7250
1	0	0	1	0	0	0.7125
1	0	0	1	0	1	0.7000
1	0	0	1	1	0	0.6875

TABLE 5. AMD 6-BIT VOLTAGE IDENTIFICATION CODES (Continued)

VID5	VID4	VID3	VID2	VID1	VID0	VDAC
1	0	0	1	1	1	0.6750
1	0	1	0	0	0	0.6625
1	0	1	0	0	1	0.6500
1	0	1	0	1	0	0.6375
1	0	1	0	1	1	0.6250
1	0	1	1	0	0	0.6125
1	0	1	1	0	1	0.6000
1	0	1	1	1	0	0.5875
1	0	1	1	1	1	0.5750
1	1	0	0	0	0	0.5625
1	1	0	0	0	1	0.5500
1	1	0	0	1	0	0.5375
1	1	0	0	1	1	0.5250
1	1	0	1	0	0	0.5125
1	1	0	1	0	1	0.5000
1	1	0	1	1	0	0.4875
1	1	0	1	1	1	0.4750
1	1	1	0	0	0	0.4625
1	1	1	0	0	1	0.4500
1	1	1	0	1	0	0.4375
1	1	1	0	1	1	0.4250
1	1	1	1	0	0	0.4125
1	1	1	1	0	1	0.4000
1	1	1	1	1	0	0.3875
1	1	1	1	1	1	0.3750

Voltage Regulation

The integrating compensation network shown in [Figure 6](#) insures that the steady-state error in the output voltage is limited only to the error in the reference voltage (output of the DAC) and offset errors in the OFS current source, remote-sense and error amplifiers. Intersil specifies the guaranteed tolerance of the ISL6312A to include the combined tolerances of each of these elements.

The output of the error amplifier, V_{COMP} , is compared to the triangle waveform to generate the PWM signals. The PWM signals control the timing of the Internal MOSFET drivers and regulate the converter output so that the voltage at FB is equal to the voltage at REF. This will regulate the output voltage to be equal to [Equation 8](#). The internal and external circuitry that controls voltage regulation is illustrated in [Figure 6](#).

$$V_{OUT} = V_{REF} - V_{OFS} - V_{DROOP} \quad (\text{EQ. 8})$$

The ISL6312A incorporates an internal differential remote-sense amplifier in the feedback path. The amplifier removes the voltage error encountered, when measuring the output voltage relative to the controller ground reference point resulting in a more accurate means of sensing output voltage. Connect the microprocessor sense pins to the non-inverting input, VSEN, and inverting input, RGND, of the remote-sense amplifier. The remote-sense output, V_{DIFF}, is connected to the inverting input of the error amplifier through an external resistor.

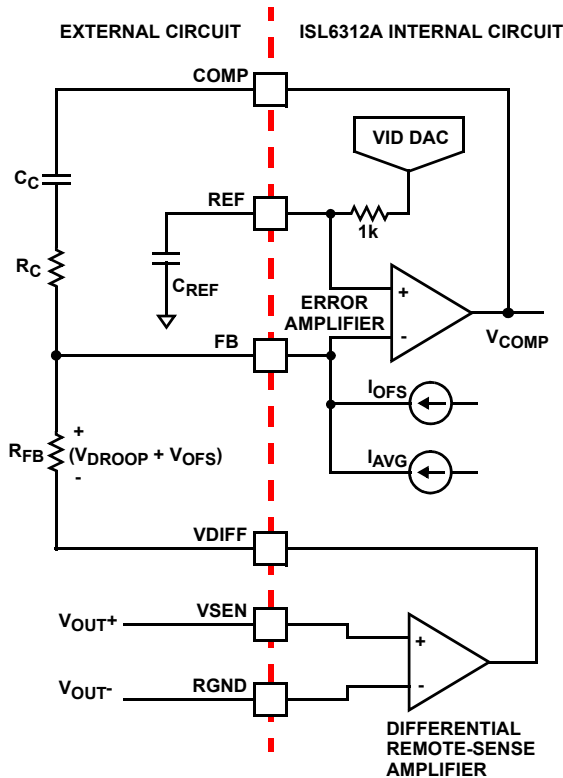

FIGURE 6. OUTPUT VOLTAGE AND LOAD-LINE REGULATION WITH OFFSET ADJUSTMENT

Load-Line (Droop) Regulation

Some microprocessor manufacturers require a precisely controlled output resistance. This dependence of output voltage on load current is often termed “droop” or “load-line” regulation. By adding a well controlled output impedance, the output voltage can effectively be level shifted in a direction which works to achieve the load-line regulation required by these manufacturers.

In other cases, the designer may determine that a more cost-effective solution can be achieved by adding droop. Droop can help to reduce the output voltage spike that results from fast load-current demand changes.

The magnitude of the spike is dictated by the ESR and ESL of the output capacitors selected. By positioning the no-load

voltage level near the upper specification limit, a larger negative spike can be sustained without crossing the lower limit. By adding a well controlled output impedance, the output voltage under load can effectively be level shifted down so that a larger positive spike can be sustained without crossing the upper specification limit.

As shown in [Figure 6](#), a current proportional to the average current of all active channels, I_{AVG} , flows from FB through a load-line regulation resistor R_{FB} . The resulting voltage drop across R_{FB} is proportional to the output current, effectively creating an output voltage droop with a steady-state value defined as:

$$V_{DROOP} = I_{AVG} \cdot R_{FB} \quad (\text{EQ. 9})$$

The regulated output voltage is reduced by the droop voltage V_{DROOP} . The output voltage as a function of load current is derived by combining [Equations 7, 8 and 9](#).

$$V_{OUT} = V_{REF} - V_{OFS} - \left(\frac{I_{OUT}}{N} \cdot \frac{DCR}{R_{ISEN}} \cdot R_{FB} \right) \quad (\text{EQ. 10})$$

In Equation 10, V_{REF} is the reference voltage, V_{OFS} is the programmed offset voltage, I_{OUT} is the total output current of the converter, R_{ISEN} is the internal sense resistor connected to the ISEN+ pin, R_{FB} is the feedback resistor, N is the active channel number, and DCR is the Inductor DCR value. Therefore the equivalent loadline impedance, i.e. droop impedance, is equal to [Equation 11](#):

$$R_{LL} = \frac{R_{FB}}{N} \cdot \frac{DCR}{R_{ISEN}} \quad (\text{EQ. 11})$$

Output Voltage Offset Programming

The ISL6312A allows the designer to accurately adjust the offset voltage by connecting a resistor, R_{OFS} , from the OFS pin to VCC or GND. When R_{OFS} is connected between OFS and VCC, the voltage across it is regulated to 1.6V. This causes a proportional current (I_{OFS}) to flow into the FB pin. If R_{OFS} is connected to ground, the voltage across it is regulated to 0.4V, and I_{OFS} flows out of the FB pin. The offset current flowing through the resistor between V_{DIFF} and FB will generate the desired offset voltage, which is equal to the product ($I_{OFS} \times R_{FB}$). These functions are shown in [Figures 7 and 8](#).

Once the desired output offset voltage has been determined, use the following formulas to set R_{OFS} :

For Negative Offset (connect R_{OFS} to GND):

$$R_{OFS} = \frac{0.4 \cdot R_{FB}}{V_{OFFSET}} \quad (\text{EQ. 12})$$

For Positive Offset (connect R_{OFS} to VCC):

$$R_{OFS} = \frac{1.6 \cdot R_{FB}}{V_{OFFSET}} \quad (\text{EQ. 13})$$

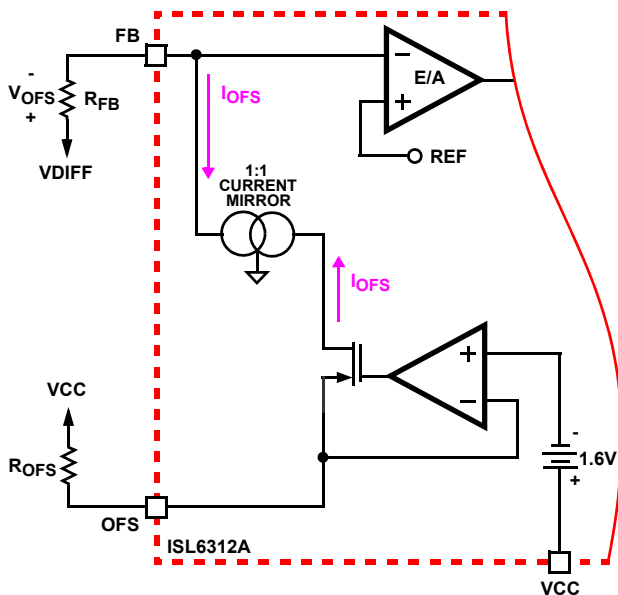

FIGURE 7. POSITIVE OFFSET OUTPUT VOLTAGE PROGRAMMING

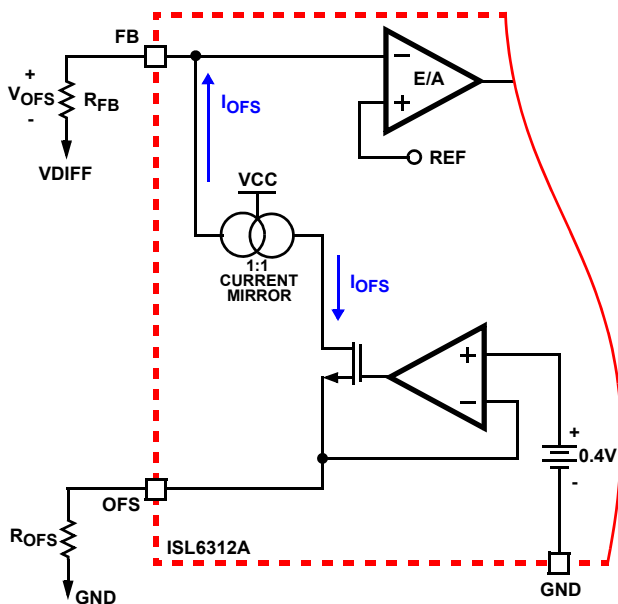

FIGURE 8. NEGATIVE OFFSET OUTPUT VOLTAGE PROGRAMMING

Dynamic VID

Modern microprocessors need to make changes to their core voltage as part of normal operation. They direct the ISL6312A to do this by making changes to the VID inputs. The ISL6312A is required to monitor the DAC inputs and respond to on-the-fly VID changes in a controlled manner, supervising a safe output voltage transition without discontinuity or disruption. The DAC mode for the ISL6312A is operating in determines how the controller responds to a dynamic VID change.

INTEL DYNAMIC VID TRANSITIONS

When in Intel VR10 or VR11 mode the ISL6312A checks the VID inputs on the positive edge of an internal 3MHz clock. If a new code is established and it remains stable for 3 consecutive readings ($1\mu\text{s}$ to $1.33\mu\text{s}$), the ISL6312A recognizes the new code and changes the internal DAC reference directly to the new level. The Intel processor controls the VID transitions and is responsible for incrementing or decrementing one VID step at a time. In VR10 and VR11 settings, the ISL6312A will immediately change the internal DAC reference to the new requested value as-soon-as the request is validated, which means the fastest recommended rate at which a bit change can occur once every $2\mu\text{s}$. In cases where the reference step is too large, the sudden change can trigger overcurrent or overvoltage events.

In order to ensure the smooth transition of output voltage during a VR10 or VR11 VID change, a VID step change smoothing network is required. This network is composed of an internal $1\text{k}\Omega$ resistor between the DAC and the REF pin, and the external capacitor C_{REF} , between the REF pin and ground. The selection of C_{REF} is based on the time duration for 1-bit VID change and the allowable delay time.

Assuming the microprocessor controls the VID change at 1-bit every T_{VID} , the relationship between C_{REF} and T_{VID} is given by Equation 14.

$$C_{\text{REF}} = 0.001(\text{S}) \cdot T_{\text{VID}} \quad (\text{EQ. 14})$$

As an example, for a VID step change rate of $5\mu\text{s}$ per bit, the value of C_{REF} is 5600pF based on Equation 14.

AMD DYNAMIC VID TRANSITIONS

When running in AMD 5-bit or 6-bit modes of operation, the ISL6312A responds differently to a dynamic VID change when is in Intel VR10 or VR11 mode. In the AMD modes the ISL6312A still checks the VID inputs on the positive edge of an internal 3MHz clock. In these modes the VID code can be changed by more than a 1-bit step at a time. If a new code is established and it remains stable for 3 consecutive readings ($1\mu\text{s}$ to $1.33\mu\text{s}$), the ISL6312A recognizes the change and begins slewing the DAC in 6.25mV steps at a stepping frequency of 330kHz until the VID and DAC are equal. Thus, the total time required for a VID change, t_{DVID} , is dependent only on the size of the VID change (ΔV_{VID}).

The time required for a ISL6312A based converter in AMD 5-bit DAC configuration to make a 1.1V to 1.5V reference voltage change is about $194\mu\text{s}$, as calculated using Equation 15.

$$t_{\text{DVID}} = \frac{1}{330 \times 10^3} \cdot \left(\frac{\Delta V_{\text{VID}}}{0.00625} \right) \quad (\text{EQ. 15})$$

In order to ensure the smooth transition of output voltage during an AMD VID change, a VID step change smoothing network is required. This network is composed of an internal 1k Ω resistor between the DAC and the REF pin, and the external capacitor C_{REF} between the REF pin and ground. For AMD VID transitions C_{REF} should be a 1000pF capacitor.

User Selectable Adaptive Deadtime Control Techniques

The ISL6312A integrated drivers incorporate two different adaptive deadtime control techniques, which the user can choose between. Both of these control techniques help to minimize deadtime, resulting in high efficiency from the reduced freewheeling time of the lower MOSFET body-diode conduction, and both help to prevent the upper and lower MOSFETs from conducting simultaneously. This is accomplished by ensuring either rising gate turns on its MOSFET with minimum and sufficient delay after the other has turned off.

The difference between the two adaptive deadtime control techniques is the method in which they detect that the lower MOSFET has transitioned off in order to turn on the upper MOSFET. The state of the DRSEL pin chooses, which of the two control techniques is active. By tying the DRSEL pin directly to ground, the PHASE Detect Scheme is chosen, which monitors the voltage on the PHASE pin to determine if the lower MOSFET has transitioned off or not. Tying the DRSEL pin to VCC through a 50k Ω resistor selects the LGATE Detect Scheme, which monitors the voltage on the LGATE pin to determine if the lower MOSFET has turned off or not. For both schemes, the method for determining whether the upper MOSFET has transitioned off in order to signal to turn on the lower MOSFET is the same.

PHASE DETECT

If the DRSEL pin is tied directly to ground, the PHASE Detect adaptive deadtime control technique is selected. For the PHASE detect scheme, during turn-off of the lower MOSFET, the PHASE voltage is monitored until it reaches a -0.3V to +0.8V (forward/reverse inductor current). At this time the UGATE is released to rise. An auto-zero comparator is used to correct the $r_{DS(ON)}$ drop in the phase voltage preventing false detection of the -0.3V phase level during $r_{DS(ON)}$ conduction period. In the case of zero current, the UGATE is released after 35ns delay of the LGATE dropping below 0.5V. When LGATE first begins to transition low, this quick transition can disturb the PHASE node and cause a false trip, so there is 20ns of blanking time once LGATE falls until PHASE is monitored.

Once the PHASE is high, the advanced adaptive shoot-through circuitry monitors the PHASE and UGATE voltages during a PWM falling edge and the subsequent UGATE turn-off. If either the UGATE falls to less than 1.75V above the PHASE or the PHASE falls to less than +0.8V, the LGATE is released to turn-on.

LGATE DETECT

If the DRSEL pin is tied to VCC through a 50k Ω resistor, the LGATE Detect adaptive deadtime control technique is selected. For the LGATE detect scheme, during turn-off of the lower MOSFET, the LGATE voltage is monitored until it reaches 1.75V. At this time the UGATE is released to rise.

Once the PHASE is high, the advanced adaptive shoot-through circuitry monitors the PHASE and UGATE voltages during a PWM falling edge and the subsequent UGATE turn-off. If either the UGATE falls to less than 1.75V above the PHASE or the PHASE falls to less than +0.8V, the LGATE is released to turn on.

Internal Bootstrap Device

All three integrated drivers feature an internal bootstrap schottky diode. Simply adding an external capacitor across the BOOT and PHASE pins completes the bootstrap circuit. The bootstrap function is also designed to prevent the bootstrap capacitor from overcharging due to the large negative swing at the PHASE node. This reduces voltage stress on the boot to phase pins.

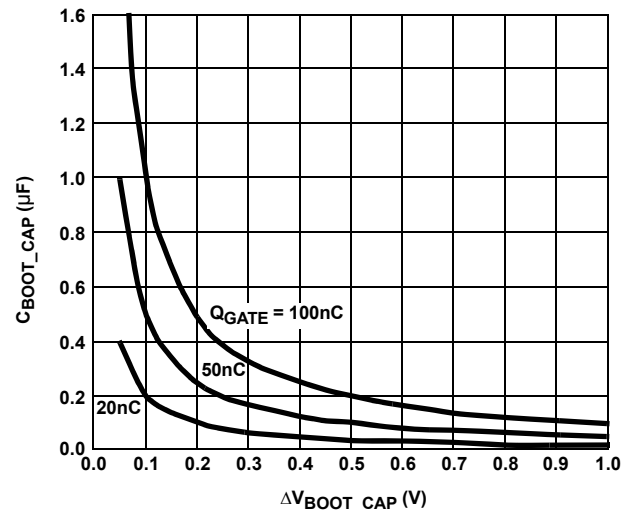

FIGURE 9. BOOTSTRAP CAPACITANCE vs BOOT RIPPLE VOLTAGE

The bootstrap capacitor must have a maximum voltage rating above $PVCC + 4V$ and its capacitance value can be chosen from [Equation 16](#):

$$C_{BOOT_CAP} \geq \frac{Q_{GATE}}{\Delta V_{BOOT_CAP}} \quad (\text{EQ. 16})$$

$$Q_{GATE} = \frac{Q_{G1} \cdot PVCC}{V_{GS1}} \cdot N_{Q1}$$

where Q_{G1} is the amount of gate charge per upper MOSFET at V_{GS1} gate-source voltage and N_{Q1} is the number of control MOSFETs. The ΔV_{BOOT_CAP} term is defined as the allowable droop in the rail of the upper gate drive.

Gate Drive Voltage Versatility

The ISL6312A provides the user flexibility in choosing the gate drive voltage for efficiency optimization. The controller ties the upper and lower drive rails together. Simply applying a voltage from 5V up to 12V on PVCC sets both gate drive rail voltages simultaneously.

Initialization

Prior to initialization, proper conditions must exist on the EN, VCC, PVCC and the VID pins. When the conditions are met, the controller begins soft-start. Once the output voltage is within the proper window of operation, the controller asserts PGOOD.

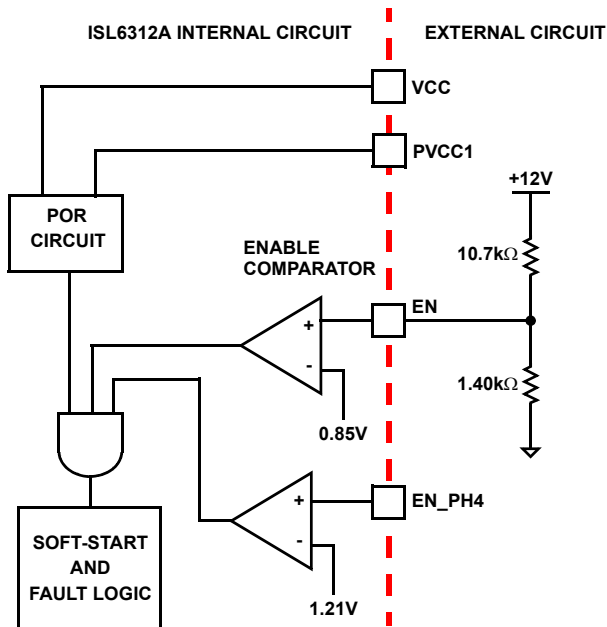

FIGURE 10. POWER SEQUENCING USING THRESHOLD-SENSITIVE ENABLE (EN)

Enable and Disable

While in shutdown mode, the PWM outputs are held in a high-impedance state to assure the drivers remain off. The following input conditions must be met, for both Intel and AMD modes of operation, before the ISL6312A is released from shutdown mode to begin the soft-start and start-up sequence:

1. The bias voltage applied at VCC must reach the internal power-on reset (POR) rising threshold. Once this threshold is reached, proper operation of all aspects of the ISL6312A is guaranteed. Hysteresis between the rising and falling thresholds assure that once enabled, the ISL6312A will not inadvertently turn off unless the bias voltage drops substantially (see "Electrical Specifications" on [page 7](#)).
2. The voltage on EN must be above 0.85V. The EN input allows for power sequencing between the controller bias voltage and another voltage rail. The enable comparator holds the ISL6312A in shutdown until the voltage at EN

risers above 0.85V. The enable comparator has 110mV of hysteresis to prevent bounce.

3. The voltage on the EN_PH4 pin must be above 1.21V. The EN_PH4 input allows for power sequencing between the controller and the external driver.
4. The driver bias voltage applied at the PVCC pins must reach the internal power-on reset (POR) rising threshold. In order for the ISL6312A to begin operation, PVCC1 is the only pin that is required to have a voltage applied that exceeds POR. However, for 2- or 3-phase operation PVCC2 and PVCC3 must also exceed the POR threshold. Hysteresis between the rising and falling thresholds assure that once enabled, the ISL6312A will not inadvertently turn off unless the PVCC bias voltage drops substantially (see "[Electrical Specifications](#)" on [page 7](#)).

For Intel VR10, VR11 and AMD 6-bit modes of operation these are the only conditions that must be met for the controller to immediately begin the soft-start sequence. If running in AMD 5-bit mode of operation there is one more condition that must be met:

5. The VID code must not be 11111 in AMD 5-bit mode. This code signals the controller that no load is present. The controller will not allow soft-start to begin if this VID code is present on the VID pins.

Once all of these conditions are met the controller will begin the soft-start sequence and will ramp the output voltage up to the user designated level.

Intel Soft-Start

The soft-start function allows the converter to bring up the output voltage in a controlled fashion, resulting in a linear ramp-up. The soft-start sequence for the Intel modes of operation is slightly different than the AMD soft-start sequence.

For the Intel VR10 and VR11 modes of operation, the soft-start sequence is composed of four periods, as shown in [Figure 6](#) on [page 20](#). Once the ISL6312A is released from shutdown and soft-start begins (as described in "[Enable and Disable](#)" on [page 23](#)), the controller will have fixed delay period TD1. After this delay period, the VR will begin first soft-start ramp until the output voltage reaches 1.1V VBOOT voltage. Then, the controller will regulate the VR voltage at 1.1V for another fixed period TD3. At the end of TD3 period, ISL6312A will read the VID signals. If the VID code is valid, ISL6312A will initiate the second soft-start ramp until the output voltage reaches the VID voltage plus/minus any offset or droop voltage.

The soft-start time is the sum of the 4 periods as shown in [Equation 17](#).

$$T_{SS} = TD1 + TD2 + TD3 + TD4 \quad (\text{EQ. 17})$$

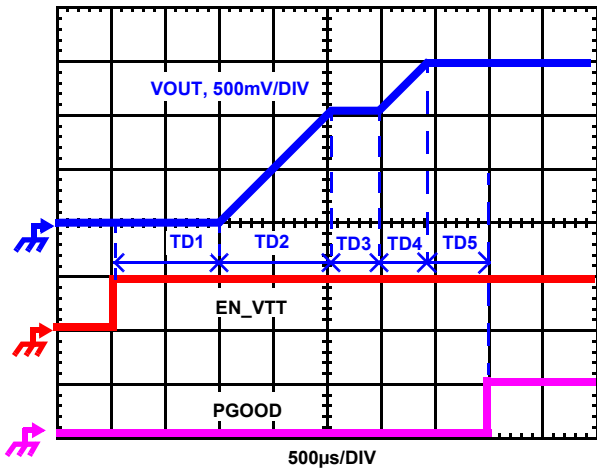

FIGURE 11. SOFT-START WAVEFORMS

TD1 is a fixed delay with the typical value as 1.40ms. TD3 is determined by the fixed 85µs plus the time to obtain valid VID voltage. If the VID is valid before the output reaches the 1.1V, the minimum time to validate the VID input is 500ns. Therefore the minimum TD3 is about 86µs.

During TD2 and TD4, ISL6312A digitally controls the DAC voltage change at 6.25mV per step. The time for each step is determined by the frequency of the soft-start oscillator which is defined by the resistor R_{SS} from SS pin to GND. The second soft-start ramp time TD2 and TD4 can be calculated based on [Equations 18 and 19](#):

$$TD2 = \frac{1.1 \cdot R_{SS}}{6.25 \cdot 25} (\mu s) \quad (\text{EQ. 18})$$

$$TD4 = \frac{(V_{VID} - 1.1) \cdot R_{SS}}{6.25 \cdot 25} (\mu s) \quad (\text{EQ. 19})$$

For example, when VID is set to 1.5V and the R_{SS} is set at 100kΩ, the first soft-start ramp time TD2 will be 704µs and the second soft-start ramp time TD4 will be 256µs.

NOTE: If the SS pin is grounded, the soft-start ramp in TD2 and TD4 will be defaulted to a 6.25mV step frequency of 330kHz.

After the DAC voltage reaches the final VID setting, PGOOD will be set to high with the fixed delay TD5. The typical value for TD5 is 440µs.

AMD Soft-Start

For the AMD 5-bit and 6-bit modes of operation, the soft-start sequence is composed of three periods, as shown in [Figure 12](#). At the beginning of soft-start, the VID code is immediately obtained from the VID pins, followed by a fixed delay period TDA. After this delay period the ISL6312A will begin ramping the output voltage to the desired DAC level at a fixed rate of 6.25mV per step, with a stepping frequency of 330kHz. The amount of time required to ramp the output voltage to the final DAC voltage is referred to as TDB, and can be calculated as shown in [Equation 20](#).

$$TDB = \frac{1}{330 \times 10^3} \cdot \left(\frac{V_{VID}}{0.00625} \right) \quad (\text{EQ. 20})$$

After the DAC voltage reaches the final VID setting, PGOOD will be set to high with the fixed delay TDC. The typical value for TDC can range between 1.5ms and 3.0ms.

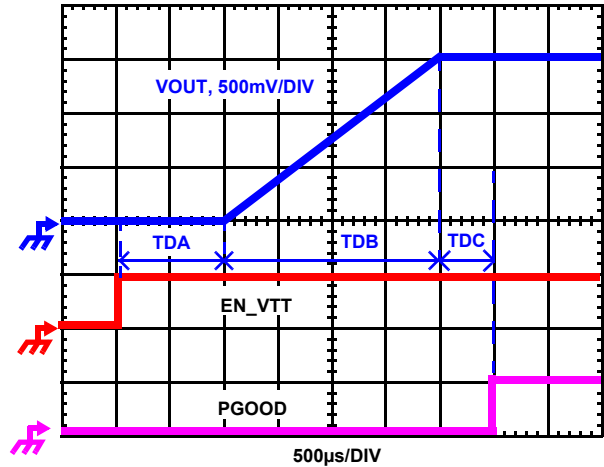

FIGURE 12. SOFT-START WAVEFORMS

Pre-Biased Soft-Start

The ISL6312A also has the ability to start up into a pre-charged output, without causing any unnecessary disturbance. The FB pin is monitored during soft-start, and should it be higher than the equivalent internal ramping reference voltage, the output drives hold both MOSFETs off.

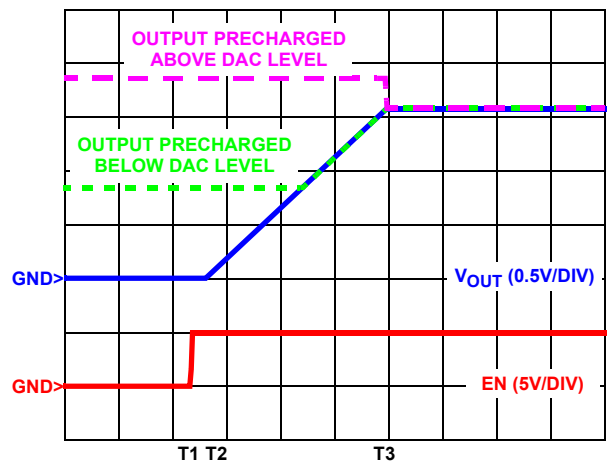

FIGURE 13. SOFT-START WAVEFORMS FOR ISL6312A BASED MULTIPHASE CONVERTER

Once the internal ramping reference exceeds the FB pin potential, the output drives are enabled, allowing the output to ramp from the pre-charged level to the final level dictated by the DAC setting. Should the output be pre-charged to a level exceeding the DAC setting, the output drives are enabled at the end of the soft-start period, leading to an abrupt correction in the output voltage down to the DAC-set level.

power supply cuts off. For complete protection, the low side MOSFET should have a gate threshold well below the maximum voltage rating of the load/microprocessor.

In the event that during normal operation the PVCC or V_{CC} voltage falls back below the POR threshold, the pre-POR overvoltage protection circuitry reactivates to protect from any more pre-POR overvoltage events.

Undervoltage Detection

The undervoltage threshold is set at 60% of the VID code. When the output voltage (VSEN-RGND) is below the undervoltage threshold, PGOOD gets pulled low. No other action is taken by the controller. PGOOD will return high if the output voltage rises above 70% of the VID code.

Open Sense Line Prevention

In the case that either of the remote sense lines, VSEN or GND, become open, the ISL6312A is designed to prevent the controller from regulating. This is accomplished by means of a small 5µA pull-up current on VSEN, and a pull-down current on RGND. If the sense lines are opened at any time, the voltage difference between VSEN and RGND will increase until an overvoltage event occurs, at which point overvoltage protection activates and the controller stops regulating. The ISL6312A will be latched off and cannot be restarted until the controller is reset.

Overcurrent Protection

The ISL6312A takes advantage of the proportionality between the load current and the average current, I_{AVG}, to detect an overcurrent condition. Two different methods of detecting overcurrent events are available on the ISL6312A. The first method continually compares the average sense current with a constant 125µA OCP reference current as shown in [Figure 14](#). Once the average sense current exceeds the OCP reference current, a comparator triggers the converter to begin overcurrent protection procedures.

This first method for detecting overcurrent events limits the minimum overcurrent trip threshold because of the fact the ISL6312A uses set internal R_{ISEN} current sense resistors. For this first method the minimum overcurrent trip threshold is dictated by the DCR of the inductors and the number of active channels. To calculate the minimum overcurrent trip level, I_{OCP,(min)}, use [Equation 21](#), where N is the number of active channels, DCR is the individual inductor's DCR, and R_{ISEN} is the 300Ω internal current sense resistor.

$$I_{OCP,(min)} = \frac{125 \cdot 10^{-6} \cdot R_{ISEN} \cdot N}{DCR} \quad (\text{EQ. 21})$$

If the desired overcurrent trip level is greater than the minimum overcurrent trip level, I_{OCP,min}, then the resistor divider R-C circuit around the inductor shown in [Figure 5](#) should be used to set the desired trip level.

$$I_{OCP} = \left(\frac{125 \cdot 10^{-6} \cdot R_{ISEN} \cdot N}{DCR} \right) \cdot \left(\frac{R_1 + R_2}{R_2} \right) \quad (\text{EQ. 22})$$

$$I_{OCP} > I_{OCP,(min)}$$

If an overcurrent trip level lower than I_{OCP,(min)} is desired, then a second method for setting the OCP trip level is available.

The second method for detecting overcurrent events continuously compares the voltage on the IOUT pin, VIOUT, to the overcurrent protection voltage, V_{OCP}, as shown in [Figure 14](#). The average channel sense current flows out the IOUT pin and through R_{IOUT}, creating the IOUT pin voltage which is proportional to the output current. When the IOUT pin voltage exceeds the V_{OCP} voltage of 2.0V, the overcurrent protection circuitry activates. Since the IOUT pin voltage is proportional to the output current, the overcurrent trip level, I_{OCP}, can be set by selecting the proper value for R_{IOUT}, as shown in [Equation 23](#).

$$I_{OCP} = \frac{V_{OCP} \cdot R_{ISEN} \cdot n}{DCR \cdot R_{IOUT}} \quad I_{OCP} < I_{OCP,(min)} \quad (\text{EQ. 23})$$

Once the output current exceeds the overcurrent trip level, VIOUT will exceed V_{OCP} and a comparator will trigger the converter to begin overcurrent protection procedures.

At the beginning of an overcurrent shutdown, the controller turns off both upper and lower MOSFETs. The system remains in this state for fixed period of 12ms. If the controller is still enabled at the end of this wait period, it will attempt a soft-start. If the fault remains, the trip-retry cycles will continue indefinitely until either the controller is disabled or the fault is cleared. Note that the energy delivered during trip-retry cycling is much less than during full-load operation, so there is no thermal hazard.

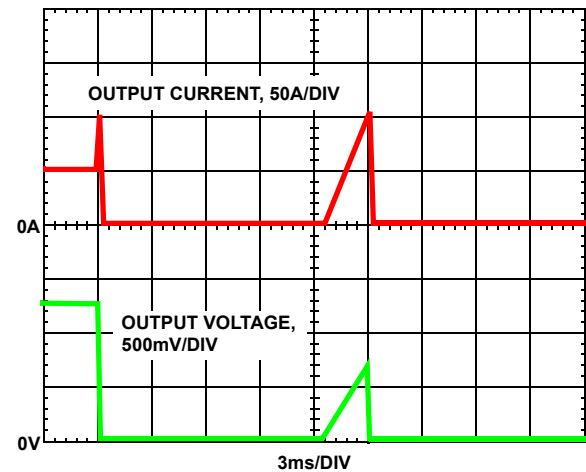

FIGURE 15. OVERCURRENT BEHAVIOR IN HICCUP MODE

Individual Channel Overcurrent Limiting

The ISL6312A has the ability to limit the current in each individual channel without shutting down the entire regulator. This is accomplished by continuously comparing the sensed currents of each channel with a constant 170µA OCL reference current as shown in [Figure 14](#). If a channel's individual sensed current exceeds this OCL limit, the UGATE signal of that channel is immediately forced low, and the LGATE signal is forced high. This turns off the upper MOSFET(s), turns on the lower MOSFET(s), and stops the rise of current in that channel, forcing the current in the channel to decrease. That channel's UGATE signal will not be able to return high until the sensed channel current falls back below the 170µA reference.

General Design Guide

This design guide is intended to provide a high-level explanation of the steps necessary to create a multiphase power converter. It is assumed that the reader is familiar with many of the basic skills and techniques referenced below. In addition to this guide, Intersil provides complete reference designs that include schematics, bills of materials, and example board layouts for all common microprocessor applications.

Power Stages

The first step in designing a multiphase converter is to determine the number of phases. This determination depends heavily on the cost analysis which in turn depends on system constraints that differ from one design to the next. Principally, the designer will be concerned with whether components can be mounted on both sides of the circuit board, whether through-hole components are permitted, the total board space available for power supply circuitry, and the maximum amount of load current. Generally speaking, the most economical solutions are those in which each phase handles between 25A and 30A. All surface mount designs will tend toward the lower end of this current range. If through hole MOSFETs and inductors can be used, higher per-phase currents are possible. In cases where board space is the limiting constraint, current can be pushed as high as 40A per phase, but these designs require heat sinks and forced air to cool the MOSFETs, inductors and heat-dissipating surfaces.

MOSFETS

The choice of MOSFETs depends on the current each MOSFET will be required to conduct, the switching frequency, the capability of the MOSFETs to dissipate heat, and the availability and nature of heat sinking and air flow.

LOWER MOSFET POWER CALCULATION

The calculation for power loss in the lower MOSFET is simple, since virtually all of the loss in the lower MOSFET is due to current conducted through the channel resistance ($r_{DS(ON)}$). In [Equation 24](#), I_M is the maximum continuous output current, I_{P-P} is the peak-to-peak inductor current (see [Equation 1](#)), and d is the duty cycle (V_{OUT}/V_{IN}).

$$P_{LOW,1} = r_{DS(ON)} \cdot \left[\left(\frac{I_M}{N} \right)^2 \cdot (1-d) + \frac{(I_{L,P-P})^2 \cdot (1-d)}{12} \right] \quad (\text{EQ. 24})$$

An additional term can be added to the lower MOSFET loss equation to account for additional loss accrued during the deadtime, when inductor current is flowing through the lower MOSFET body diode. This term is dependent on the diode forward voltage at I_M , $V_{D(ON)}$, the switching frequency, f_S , and the length of dead times, t_{d1} and t_{d2} , at the beginning and the end of the lower MOSFET conduction interval respectively.

$$P_{LOW,2} = V_{D(ON)} \cdot f_S \cdot \left[\left(\frac{I_M}{N} + \frac{I_{P-P}}{2} \right) \cdot t_{d1} + \left(\frac{I_M}{N} - \frac{I_{P-P}}{2} \right) \cdot t_{d2} \right] \quad (\text{EQ. 25})$$

The total maximum power dissipated in each lower MOSFET is approximated by the summation of $P_{LOW,1}$ and $P_{LOW,2}$.

UPPER MOSFET POWER CALCULATION

In addition to $r_{DS(ON)}$ losses, a large portion of the upper MOSFET losses are due to currents conducted across the input voltage (V_{IN}) during switching. Since a substantially higher portion of the upper MOSFET losses are dependent on switching frequency, the power calculation is more complex. Upper MOSFET losses can be divided into separate components involving the upper MOSFET switching times, the lower MOSFET body-diode reverse-recovery charge, Q_{rr} , and the upper MOSFET $r_{DS(ON)}$ conduction loss.

When the upper MOSFET turns off, the lower MOSFET does not conduct any portion of the inductor current until the voltage at the phase node falls below ground. Once the lower MOSFET begins conducting, the current in the upper MOSFET falls to zero as the current in the lower MOSFET ramps up to assume the full inductor current. In [Equation 26](#), the required time for this commutation is t_1 and the approximated associated power loss is $P_{UP,1}$.

$$P_{UP,1} \approx V_{IN} \cdot \left(\frac{I_M}{N} + \frac{I_{P-P}}{2} \right) \cdot \left(\frac{t_1}{2} \right) \cdot f_S \quad (\text{EQ. 26})$$

At turn on, the upper MOSFET begins to conduct and this transition occurs over a time t_2 . In [Equation 27](#), the approximate power loss is $P_{UP,2}$.

$$P_{UP,2} \approx V_{IN} \cdot \left(\frac{I_M}{N} - \frac{I_{P-P}}{2} \right) \cdot \left(\frac{t_2}{2} \right) \cdot f_S \quad (\text{EQ. 27})$$

A third component involves the lower MOSFET reverse-recovery charge, Q_{rr} . Since the inductor current has fully commutated to the upper MOSFET before the lower MOSFET body diode can recover all of Q_{rr} , it is conducted through the upper MOSFET across V_{IN} . The power dissipated as a result is $P_{UP,3}$.

$$P_{UP,3} = V_{IN} \cdot Q_{rr} \cdot f_S \quad (\text{EQ. 28})$$

Finally, the resistive part of the upper MOSFET is given in [Equation 29](#) as $P_{UP,4}$:

$$P_{UP,4} \approx r_{DS(ON)} \cdot d \cdot \left[\left(\frac{I_M}{N} \right)^2 + \frac{I_{P,P}^2}{12} \right] \quad (\text{EQ. 29})$$

The total power dissipated by the upper MOSFET at full load can now be approximated as the summation of the results from [Equations 26, 27, 28 and 29](#). Since the power equations depend on MOSFET parameters, choosing the correct MOSFETs can be an iterative process involving repetitive solutions to the loss equations for different MOSFETs and different switching frequencies.

Package Power Dissipation

When choosing MOSFETs it is important to consider the amount of power being dissipated in the integrated drivers located in the controller. Since there are a total of three drivers in the controller package, the total power dissipated by all three drivers must be less than the maximum allowable power dissipation for the QFN package.

Calculating the power dissipation in the drivers for a desired application is critical to ensure safe operation. Exceeding the maximum allowable power dissipation level will push the IC beyond the maximum recommended operating junction temperature of +125°C. The maximum allowable IC power dissipation for the 7x7 QFN package is approximately 3.5W at room temperature. See [“Layout Considerations” on page 33](#) for thermal transfer improvement suggestions.

When designing the ISL6312A into an application, it is recommended that the following calculation is used to ensure safe operation at the desired frequency for the selected MOSFETs. The total gate drive power losses, P_{Qg_TOT} , due to the gate charge of MOSFETs and the integrated driver’s internal circuitry and their corresponding average driver current can be estimated with [Equations 30 and 31](#), respectively.

$$P_{Qg_TOT} = P_{Qg_Q1} + P_{Qg_Q2} + I_Q \cdot V_{CC} \quad (\text{EQ. 30})$$

$$P_{Qg_Q1} = \frac{3}{2} \cdot Q_{G1} \cdot PV_{CC} \cdot F_{SW} \cdot N_{Q1} \cdot N_{PHASE}$$

$$P_{Qg_Q2} = Q_{G2} \cdot PV_{CC} \cdot F_{SW} \cdot N_{Q2} \cdot N_{PHASE} \quad (\text{EQ. 31})$$

$$I_{DR} = \left(\frac{3}{2} \cdot Q_{G1} \cdot N_{Q1} + Q_{G2} \cdot N_{Q2} \right) \cdot N_{PHASE} \cdot F_{SW} + I_Q$$

In [Equations 30 and 31](#), P_{Qg_Q1} is the total upper gate drive power loss and P_{Qg_Q2} is the total lower gate drive power loss; the gate charge (Q_{G1} and Q_{G2}) is defined at the particular gate to source drive voltage PV_{CC} in the corresponding MOSFET data sheet; I_Q is the driver total quiescent current with no load at both drive outputs; N_{Q1} and N_{Q2} are the number of upper and lower MOSFETs per phase, respectively; N_{PHASE} is the number

of active phases. The $I_Q \cdot V_{CC}$ product is the quiescent power of the controller without capacitive load and is typically 75mW at 300kHz.

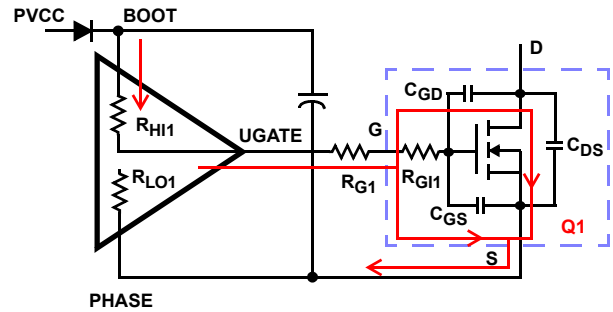

FIGURE 16. TYPICAL UPPER-GATE DRIVE TURN-ON PATH

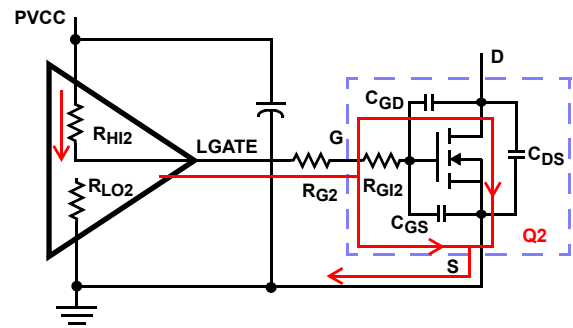

FIGURE 17. TYPICAL LOWER-GATE DRIVE TURN-ON PATH

The total gate drive power losses are dissipated among the resistive components along the transition path and in the bootstrap diode. The portion of the total power dissipated in the controller itself is the power dissipated in the upper drive path resistance, P_{DR_UP} , the lower drive path resistance, P_{DR_LOW} , and in the boot strap diode, P_{BOOT} . The rest of the power will be dissipated by the external gate resistors (R_{G1} and R_{G2}) and the internal gate resistors (R_{GI1} and R_{GI2}) of the MOSFETs.

[Figures 16 and 17](#) show the typical upper and lower gate drives turn-on transition path. The total power dissipation in the controller itself, P_{DR} , can be roughly estimated as:

$$P_{DR} = P_{DR_UP} + P_{DR_LOW} + P_{BOOT} + (I_Q \cdot V_{CC}) \quad (\text{EQ. 32})$$

$$P_{BOOT} = \frac{P_{Qg_Q1}}{3}$$

$$P_{DR_UP} = \left(\frac{R_{HI1}}{R_{HI1} + R_{EXT1}} + \frac{R_{LO1}}{R_{LO1} + R_{EXT1}} \right) \cdot \frac{P_{Qg_Q1}}{3}$$

$$P_{DR_LOW} = \left(\frac{R_{HI2}}{R_{HI2} + R_{EXT2}} + \frac{R_{LO2}}{R_{LO2} + R_{EXT2}} \right) \cdot \frac{P_{Qg_Q2}}{2}$$

$$R_{EXT1} = R_{G1} + \frac{R_{GI1}}{N_{Q1}}$$

$$R_{EXT2} = R_{G2} + \frac{R_{GI2}}{N_{Q2}}$$

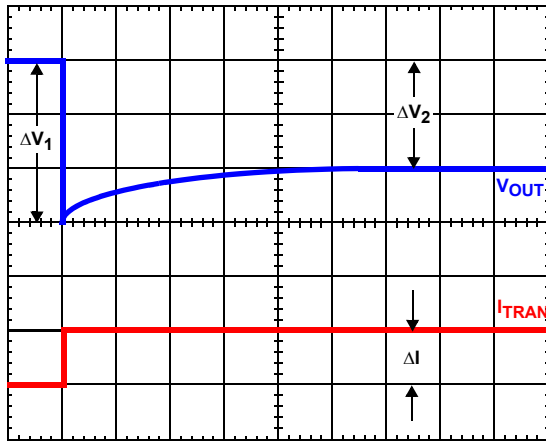

FIGURE 19. TIME CONSTANT MISMATCH BEHAVIOR

Loadline Regulation Resistor

For loadline regulation a copy of the internal average sense current flows out of the FB pin across the loadline regulation resistor, labeled R_{FB} in Figure 6. This resistor's value sets the desired loadline required for the application. The desired loadline, R_{LL} , can be calculated by the following Equation 39 where V_{DROOP} is the desired droop voltage at the full load current I_{FL} .

$$R_{LL} = \frac{V_{DROOP}}{I_{FL}} \quad (\text{EQ. 39})$$

Based on the desired loadline, the loadline regulation resistor, R_{FB} , can be calculated from Equation 40 or Equation 41, depending on the R-C current sense circuitry being employed. If a basic R-C sense circuit consisting of C_1 and R_1 is being used, use Equation 40. If a resistor divider R-C sense circuit consisting of R_1 , R_2 , and C_1 is being used, use Equation 41.

$$R_{FB} = \frac{R_{LL} \cdot N \cdot 300}{DCR} \quad (\text{EQ. 40})$$

$$R_{FB} = \frac{R_{LL} \cdot N \cdot 300 \cdot (R_1 + R_2)}{DCR \cdot R_2} \quad (\text{EQ. 41})$$

In Equations 40 and 41, R_{LL} is the loadline resistance; N is the number of active channels; DCR is the DCR of the individual output inductors; and R_1 and R_2 are the current sense R-C resistors.

IOUT Pin Resistor

A copy of the average sense current flows out of the IOUT pin, and a resistor, R_{IOUT} , placed from this pin to ground can be used to set the overcurrent protection trip level. Based on the desired overcurrent trip threshold, I_{OCP} , the IOUT pin resistor, R_{IOUT} , can be calculated from Equation 42 or Equation 43, depending on the R-C current sense circuitry being employed. If a basic R-C sense circuit consisting of C_1 and R_1 is being

used, use Equation 42. If a resistor divider R-C sense circuit consisting of R_1 , R_2 , and C_1 is being used, use Equation 43.

$$R_{IOUT} = \frac{600 \cdot N}{DCR \cdot I_{OCP}} \quad I_{OCP} \leq I_{OCP, \min} \quad (\text{EQ. 42})$$

$$R_{IOUT} = \frac{600 \cdot N}{DCR \cdot I_{OCP}} \cdot \left(\frac{R_1 + R_2}{R_2} \right) \quad I_{OCP} > I_{OCP, \min} \quad (\text{EQ. 43})$$

Compensation

The two opposing goals of compensating the voltage regulator are stability and speed.

The load-line regulated converter behaves in a similar manner to a peak current mode controller because the two poles at the output filter L-C resonant frequency split with the introduction of current information into the control loop. The final location of these poles is determined by the system function, the gain of the current signal, and the value of the compensation components, R_C and C_C .

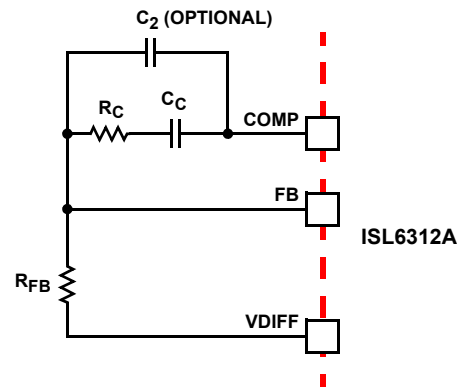

FIGURE 20. COMPENSATION CONFIGURATION FOR LOAD-LINE REGULATED ISL6312A CIRCUIT

Since the system poles and zero are affected by the values of the components that are meant to compensate them, the solution to the system equation becomes fairly complicated. Fortunately, there is a simple approximation that comes very close to an optimal solution. Treating the system as though it were a voltage-mode regulator, by compensating the L-C poles and the ESR zero of the voltage mode approximation, yields a solution that is always stable with very close to ideal transient performance.

Select a target bandwidth for the compensated system, f_0 . The target bandwidth must be large enough to assure adequate transient performance, but smaller than 1/3 of the per-channel switching frequency. The values of the compensation components depend on the relationships of f_0 to the L-C pole frequency and the ESR zero frequency. For each of the following three, there is a separate set of equations for the compensation components.

$$\begin{aligned}
 \text{Case 1: } & \frac{1}{2 \cdot \pi \cdot \sqrt{L \cdot C}} > f_0 \\
 & R_C = R_{FB} \cdot \frac{2 \cdot \pi \cdot f_0 \cdot V_{P-P} \cdot \sqrt{L \cdot C}}{0.66 \cdot V_{IN}} \\
 & C_C = \frac{0.66 \cdot V_{IN}}{2 \cdot \pi \cdot V_{P-P} \cdot R_{FB} \cdot f_0} \\
 \\
 \text{Case 2: } & \frac{1}{2 \cdot \pi \cdot \sqrt{L \cdot C}} \leq f_0 < \frac{1}{2 \cdot \pi \cdot C \cdot ESR} \\
 & R_C = R_{FB} \cdot \frac{V_{P-P} \cdot (2 \cdot \pi)^2 \cdot f_0^2 \cdot L \cdot C}{0.66 \cdot V_{IN}} \quad (\text{EQ. 44}) \\
 & C_C = \frac{0.66 \cdot V_{IN}}{(2 \cdot \pi)^2 \cdot f_0^2 \cdot V_{P-P} \cdot R_{FB} \cdot \sqrt{L \cdot C}} \\
 \\
 \text{Case 3: } & f_0 > \frac{1}{2 \cdot \pi \cdot C \cdot ESR} \\
 & R_C = R_{FB} \cdot \frac{2 \cdot \pi \cdot f_0 \cdot V_{P-P} \cdot L}{0.66 \cdot V_{IN} \cdot ESR} \\
 & C_C = \frac{0.66 \cdot V_{IN} \cdot ESR \cdot \sqrt{C}}{2 \cdot \pi \cdot V_{P-P} \cdot R_{FB} \cdot f_0 \cdot \sqrt{L}}
 \end{aligned}$$

In [Equation 44](#), L is the per-channel filter inductance divided by the number of active channels; C is the sum total of all output capacitors; ESR is the equivalent series resistance of the bulk output filter capacitance; and V_{P-P} is the peak-to-peak sawtooth signal amplitude as described in the [“Electrical Specifications”](#) on [page 7](#).

Once selected, the compensation values in [Equation 44](#) assure a stable converter with reasonable transient performance. In most cases, transient performance can be improved by making adjustments to R_C . Slowly increase the value of R_C while observing the transient performance on an oscilloscope until no further improvement is noted. Normally, C_C will not need adjustment. Keep the value of C_C from [Equation 44](#) unless some performance issue is noted.

The optional capacitor C_2 , is sometimes needed to bypass noise away from the PWM comparator (see [Figure 20](#)). Keep a position available for C_2 , and be prepared to install a high frequency capacitor of between 22pF and 150pF in case any leading edge jitter problem is noted.

Output Filter Design

The output inductors and the output capacitor bank together to form a low-pass filter responsible for smoothing the pulsating voltage at the phase nodes. The output filter also must provide the transient energy until the regulator can respond. Because it has a low bandwidth compared to the switching frequency, the output filter limits the system transient response. The output capacitors must supply or sink load current while the current in the output inductors increases or decreases to meet the demand.

In high-speed converters, the output capacitor bank is usually the most costly (and often the largest) part of the circuit. Output filter design begins with minimizing the cost of this part of the circuit. The critical load parameters in choosing the output capacitors are the maximum size of the load step, ΔI , the load-current slew rate, di/dt , and the maximum allowable output voltage deviation under transient loading, ΔV_{MAX} . Capacitors are characterized according to their capacitance, ESR, and ESL (equivalent series inductance).

At the beginning of the load transient, the output capacitors supply all of the transient current. The output voltage will initially deviate by an amount approximated by the voltage drop across the ESL. As the load current increases, the voltage drop across the ESR increases linearly until the load current reaches its final value. The capacitors selected must have sufficiently low ESL and ESR so that the total output voltage deviation is less than the allowable maximum. Neglecting the contribution of inductor current and regulator response, the output voltage initially deviates by showing an amount on [Equation 45](#):

$$\Delta V \approx ESL \cdot \frac{di}{dt} + ESR \cdot \Delta I \quad (\text{EQ. 45})$$

The filter capacitor must have sufficiently low ESL and ESR so that $\Delta V < \Delta V_{MAX}$.

Most capacitor solutions rely on a mixture of high frequency capacitors with relatively low capacitance in combination with bulk capacitors having high capacitance but limited high frequency performance. Minimizing the ESL of the high frequency capacitors allows them to support the output voltage as the current increases. Minimizing the ESR of the bulk capacitors allows them to supply the increased current with less output voltage deviation.

The ESR of the bulk capacitors also creates the majority of the output voltage ripple. As the bulk capacitors sink and source the inductor AC ripple current (see [“Interleaving”](#) on [page 11](#) and [Equation 2](#)), a voltage develops across the bulk capacitor ESR equal to $I_{C,PP}(ESR)$. Thus, once the output capacitors are selected, the maximum allowable ripple voltage, $V_{PP(MAX)}$, determines the lower limit on the inductance.

$$L \geq ESR \cdot \frac{(V_{IN} - N \cdot V_{OUT}) \cdot V_{OUT}}{f_S \cdot V_{IN} \cdot V_{PP(MAX)}} \quad (\text{EQ. 46})$$

Since the capacitors are supplying a decreasing portion of the load current while the regulator recovers from the transient, the capacitor voltage becomes slightly depleted. The output inductors must be capable of assuming the entire load current before the output voltage decreases more than ΔV_{MAX} . This places an upper limit on inductance.

[Equation 47](#) gives the upper limit on L for the cases, when the trailing edge of the current transient causes a greater output voltage deviation than the leading edge. [Equation 47](#)

addresses the leading edge. Normally, the trailing edge dictates the selection of L because duty cycles are usually less than 50%. Nevertheless, both inequalities should be evaluated, and L should be selected based on the lower of the two results. In each equation, L is the per-channel inductance, C is the total output capacitance, and N is the number of active channels.

$$L \leq \frac{2 \cdot N \cdot C \cdot V_O}{(\Delta I)^2} \cdot [\Delta V_{MAX} - (\Delta I \cdot ESR)] \quad (EQ. 47)$$

$$L \leq \frac{1.25 \cdot N \cdot C}{(\Delta I)^2} \cdot [\Delta V_{MAX} - (\Delta I \cdot ESR)] \cdot (V_{IN} - V_O) \quad (EQ. 48)$$

Switching Frequency

There are a number of variables to consider when choosing the switching frequency, as there are considerable effects on the upper MOSFET loss calculation. These effects are outlined in *MOSFETs*, and they establish the upper limit for the switching frequency. The lower limit is established by the requirement for fast transient response and small output-voltage ripple. Choose the lowest switching frequency that allows the regulator to meet the transient-response requirements.

Switching frequency is determined by the selection of the frequency-setting resistor, R_T . [Figure 21](#) and [Equation 49](#) are provided to assist in selecting the correct value for R_T .

$$R_T = 10^{[10.61 - (1.035 \cdot \log(f_S))]} \quad (EQ. 49)$$

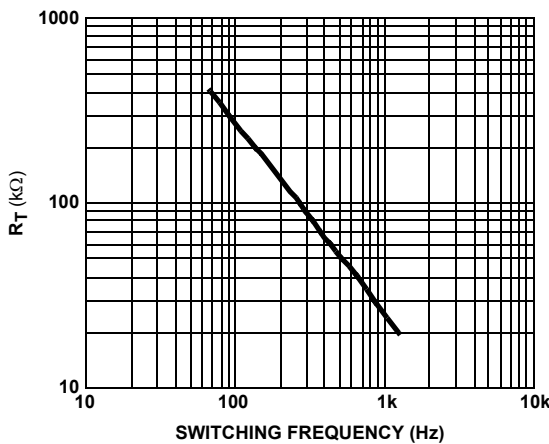

FIGURE 21. R_T vs SWITCHING FREQUENCY

Input Capacitor Selection

The input capacitors are responsible for sourcing the AC component of the input current flowing into the upper MOSFETs. Their RMS current capacity must be sufficient to handle the AC component of the current drawn by the upper MOSFETs which is related to duty cycle and the number of active phases.

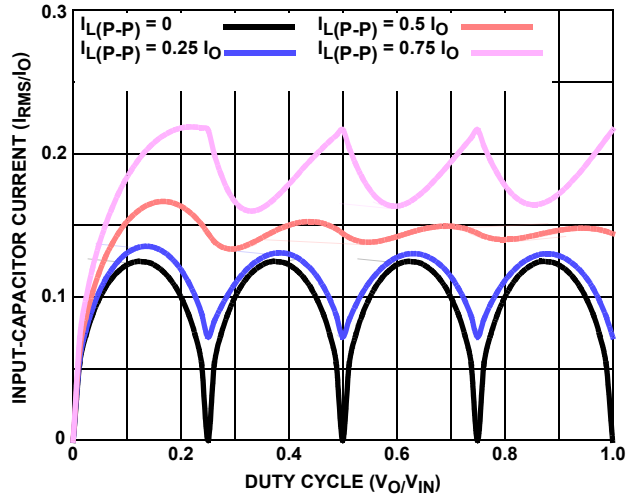

FIGURE 22. NORMALIZED INPUT-CAPACITOR RMS CURRENT vs DUTY CYCLE FOR 4-PHASE CONVERTER

For a four-phase design, use [Figure 22](#) to determine the input-capacitor RMS current requirement set by the duty cycle, maximum sustained output current (I_O), and the ratio of the peak-to-peak inductor current ($I_{L,P-P}$) to I_O . Select a bulk capacitor with a ripple current rating which will minimize the total number of input capacitors required to support the RMS current calculated.

The voltage rating of the capacitors should also be at least 1.25x greater than the maximum input voltage. [Figures 23 and 24](#) provide the same input RMS current information for three-phase and two-phase designs respectively. Use the same approach for selecting the bulk capacitor type and number.

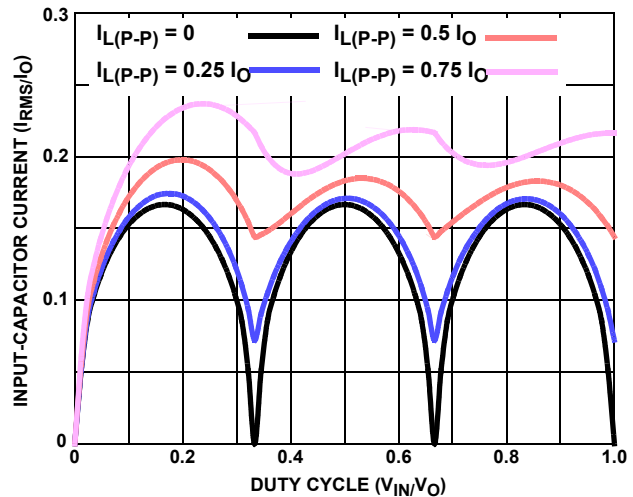

FIGURE 23. NORMALIZED INPUT-CAPACITOR RMS CURRENT FOR 3-PHASE CONVERTER

Low capacitance, high frequency ceramic capacitors are needed in addition to the input bulk capacitors to suppress leading and falling edge voltage spikes. The spikes result from the high current slew rate produced by the upper MOSFET turn on and off. Select low ESL ceramic capacitors and place one as close as possible to each upper MOSFET drain to minimize board parasitics and maximize suppression.

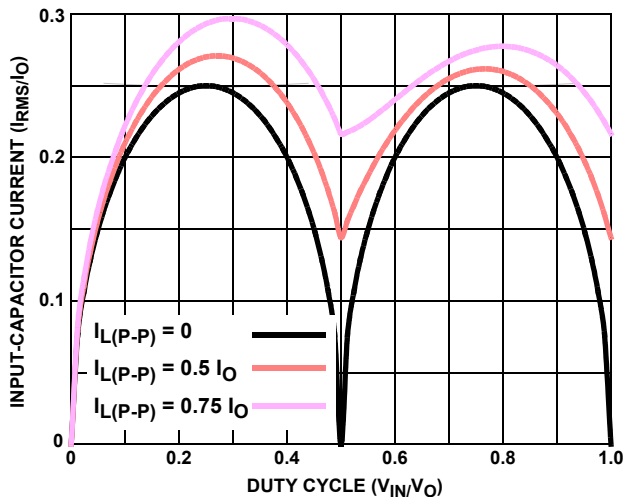

FIGURE 24. NORMALIZED INPUT-CAPACITOR RMS CURRENT FOR 2-PHASE CONVERTER

Layout Considerations

MOSFETs switch very fast and efficiently. The speed with which the current transitions from one device to another causes voltage spikes across the interconnecting impedances and parasitic circuit elements. These voltage spikes can degrade efficiency, radiate noise into the circuit and lead to device overvoltage stress. Careful component selection, layout, and placement minimizes these voltage spikes. Consider, as an example, the turn off transition of the upper PWM MOSFET. Prior to turnoff, the upper MOSFET was carrying channel current. During the turn off, current stops flowing in the upper MOSFET and is picked up by the lower MOSFET. Any inductance in the switched current path generates a large voltage spike during the switching interval. Careful component selection, tight layout of the critical components, and short, wide circuit traces minimize the magnitude of voltage spikes.

There are two sets of critical components in a DC/DC converter using a ISL6312A controller. The power components are the most critical because they switch large amounts of energy. Next are small signal components that connect to sensitive nodes or supply critical bypassing current and signal coupling.

The power components should be placed first, which include the MOSFETs, input and output capacitors, and the inductors. It is important to have a symmetrical layout for each power train, preferably with the controller located equidistant from each. Symmetrical layout allows heat to be dissipated equally across all power trains. Equidistant placement of the controller to the

first three power trains it controls through the integrated drivers helps keep the gate drive traces equally short, resulting in equal trace impedances and similar drive capability of all sets of MOSFETs.

When placing the MOSFETs try to keep the source of the upper FETs and the drain of the lower FETs as-close-as-thermally-possible. Input Bulk capacitors should be placed close to the drain of the upper FETs and the source of the lower FETs. Locate the output inductors and output capacitors between the MOSFETs and the load. The high frequency input and output decoupling capacitors (ceramic) should be placed as close as practicable to the decoupling target, making use of the shortest connection paths to any internal planes, such as vias to GND next or on the capacitor solder pad.

The critical small components include the bypass capacitors for V_{CC} and $PVCC$, and many of the components surrounding the controller including the feedback network and current sense components. Locate the $V_{CC}/PVCC$ bypass capacitors as close to the ISL6312A as possible. It is especially important to locate the components associated with the feedback circuit close to their respective controller pins, since they belong to a high-impedance circuit loop, sensitive to EMI pick-up.

A multi-layer printed circuit board is recommended. A shows the connections of the critical components for the converter. Note that capacitors C_{xxIN} and C_{xxOUT} could each represent numerous physical capacitors. Dedicate one solid layer, usually the one underneath the component side of the board, for a ground plane and make all critical component ground connections with vias to this layer.

Dedicate another solid layer as a power plane and break this plane into smaller islands of common voltage levels. Keep the metal runs from the PHASE terminal to output inductors short. The power plane should support the input power and output power nodes. Use copper filled polygons on the top and bottom circuit layers for the phase nodes. Use the remaining printed circuit layers for small signal wiring.

Routing UGATE, LGATE, and PHASE Traces

Great attention should be paid to routing the UGATE, LGATE, and PHASE traces since they drive the power train MOSFETs using short, high current pulses. It is important to size them as large and as short as possible to reduce their overall impedance and inductance. They should be sized to carry at least one ampere of current (0.02" to 0.05"). Going between layers with vias should also be avoided, but if so, use two vias for interconnection when possible.

Extra care should be given to the LGATE traces in particular since keeping their impedance and inductance low helps to significantly reduce the possibility of shoot-through. It is also important to route each channels UGATE and PHASE traces in as close proximity as possible to reduce their inductances.

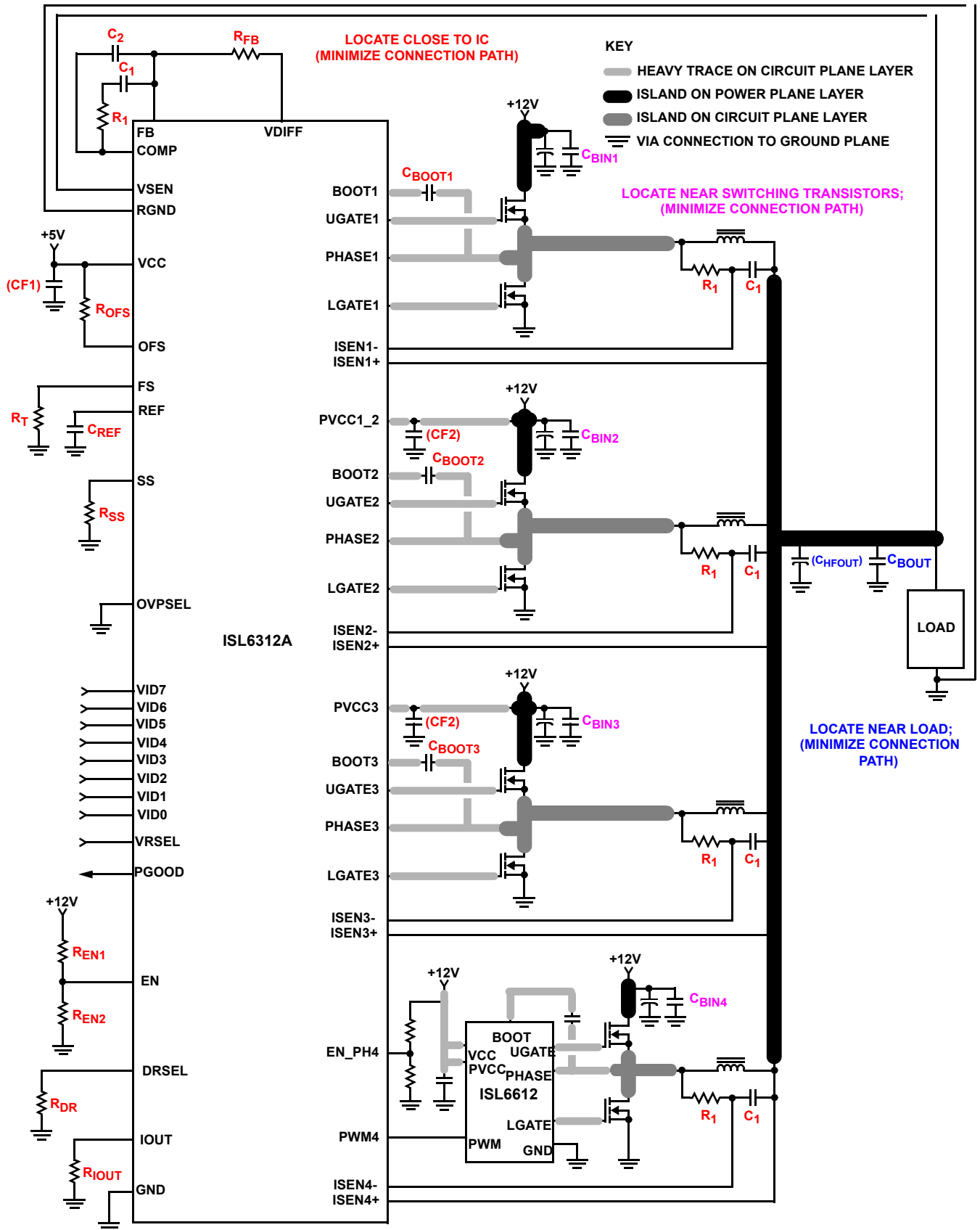

FIGURE 25. PRINTED CIRCUIT BOARD POWER PLANES AND ISLANDS

Current Sense Component Placement and Trace Routing

One of the most critical aspects of the ISL6312A regulator layout is the placement of the inductor DCR current sense components and traces. The R-C current sense components must be placed as close to their respective ISEN+ and ISEN- pins on the ISL6312A as possible.

The sense traces that connect the R-C sense components to each side of the output inductors should be routed on the bottom of the board, away from the noisy switching components located on the top of the board. These traces should be routed side by side, and they should be very thin traces. It's important to route these traces as far away from any other noisy traces or planes as possible. These traces should pick up as little noise as possible.

Thermal Management

For maximum thermal performance in high current, high switching frequency applications, connecting the thermal GND pad of the ISL6312A to the ground plane with multiple vias is recommended. This heat spreading allows the part to achieve its full thermal potential. It is also recommended that the controller be placed in a direct path of airflow if possible to help thermally manage the part.

© Copyright Intersil Americas LLC 2006-2015. All Rights Reserved.
All trademarks and registered trademarks are the property of their respective owners.

For additional products, see www.intersil.com/en/products.html

Intersil products are manufactured, assembled and tested utilizing ISO9001 quality systems as noted in the quality certifications found at www.intersil.com/en/support/qualandreliability.html

Intersil products are sold by description only. Intersil may modify the circuit design and/or specifications of products at any time without notice, provided that such modification does not, in Intersil's sole judgment, affect the form, fit or function of the product. Accordingly, the reader is cautioned to verify that datasheets are current before placing orders. Information furnished by Intersil is believed to be accurate and reliable. However, no responsibility is assumed by Intersil or its subsidiaries for its use; nor for any infringements of patents or other rights of third parties which may result from its use. No license is granted by implication or otherwise under any patent or patent rights of Intersil or its subsidiaries.

For information regarding Intersil Corporation and its products, see www.intersil.com

Looking for pricing, stock, or lifecycle information?

Click below to explore more details on WIN SOURCE:

 [View ISL6312ACRZ-T on WIN SOURCE](#)

 [Intersil Information](#)

Optimize Your Supply Chain with WIN SOURCE Solutions

-  Global Sourcing Solution
-  Obsolete Management
-  Cost Control Management
-  Shortage Management
-  Alternative Solution
-  Excess Inventory Management