



**THE DATASHEET OF
ISL6444CA**



ISL6444

Dual PWM Controller with DDR Memory Option for Gateway Applications

FN9069
Rev 3.00
Apr 12, 2007

The ISL6444 PWM controller provides high efficiency and regulation for two output voltages adjustable in the range from 0.9V to 5.5V that are required to power I/O, chip-sets, and memory banks in high-performance notebook computers, PDAs, and Internet appliances.

Synchronous rectification and hysteretic operation at light loads contribute to a high efficiency over a wide range of loads. The hysteretic mode of operation can be disabled separately on each PWM converter if continuous conduction operation is desired for all load levels. Efficiency is even further enhanced by using MOSFET's $r_{DS(ON)}$ as a current sense component.

Feed-forward ramp modulation, current mode control scheme, and internal feed-back compensation provide fast response to load transients. Out-of-phase operation with a 180° phase shift reduces the input current ripple.

The controller can be transformed in a complete DDR memory power supply solution by activating a DDR pin. In DDR mode of operation one of the channels tracks the output voltage of another channel and provides output current sink and source capability—features essential for proper powering of DDR chips. The buffered reference voltage required by this type of memory is also provided.

The ISL6444 monitors the output voltages. Each PWM controller generates a PGOOD (power good) signal when the soft-start is completed and the output is within ±10% of the set point.

A built-in overvoltage protection prevents output voltage from going above 115% of the set point. Normal operation automatically restores when the overvoltage conditions go away. Undervoltage protection latches the chip off when either output drops below 75% of its set value after the soft-start sequence for this output is completed. An adjustable overcurrent function monitors the output current by sensing the voltage drop across the lower MOSFET. If precision current-sensing is required, an external current-sense resistor may optionally be used.

The IC comes in a 28 Ld SSOP package.

Features

- Provides regulated output voltage in the range 0.9V to 5.5V
 - High efficiency over wide load range
 - Synchronous buck converter with hysteretic operation at light load
- Complete DDR memory power solution
 - VTT tracks VDDQ/2
 - VDDQ/2 buffered reference output
- No current-sense resistor required
 - Uses MOSFET's $r_{DS(ON)}$
 - Optional current-sense resistor for precision overcurrent
- Undervoltage lock-out on VCC pin
- Dual mode operation
 - Operates directly from battery 5.0V to 24V input
 - Operates from 3.3V or 5V system rail
- Excellent dynamic response
 - Combined voltage feed-forward and current mode control
- Power-good signal for each channel
- 300kHz switching frequency
 - Out-of-phase operation for reduced input ripple
 - In-phase operation in DDR mode for reduced channel interference
 - Out-of-phase operation with 90° phase shift for two-stage conversion in DDR mode
- Pb-free plus anneal available (RoHS compliant)

Applications

- Residential and Enterprise Gateways
- DSL Modems
- Routers and Switchers

Ordering Information

PART NUMBER	PART MARKING	TEMP. RANGE (°C)	PACKAGE	PKG. DWG. #
ISL6444CA*	ISL 6444CA	-10 to +85	28 Ld QSOP	M28.15
ISL6444CAZ* (Note)	ISL 6444CAZ	-10 to +85	28 Ld QSOP (Pb-free)	M28.15

*Add "-T" suffix for tape and reel.

NOTE: Intersil Pb-free plus anneal products employ special Pb-free material sets; molding compounds/die attach materials and 100% matte tin plate termination finish, which are RoHS compliant and compatible with both SnPb and Pb-free soldering operations. Intersil Pb-free products are MSL classified at Pb-free peak reflow temperatures that meet or exceed the Pb-free requirements of IPC/JEDEC J STD-020.

Pinout

ISL6444
(28 LD QSOP)
TOP VIEW

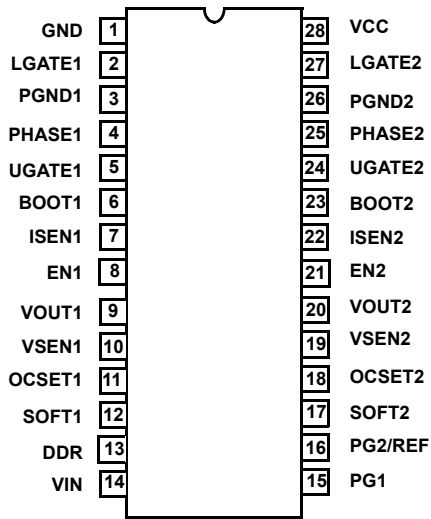

Generic Application Circuits

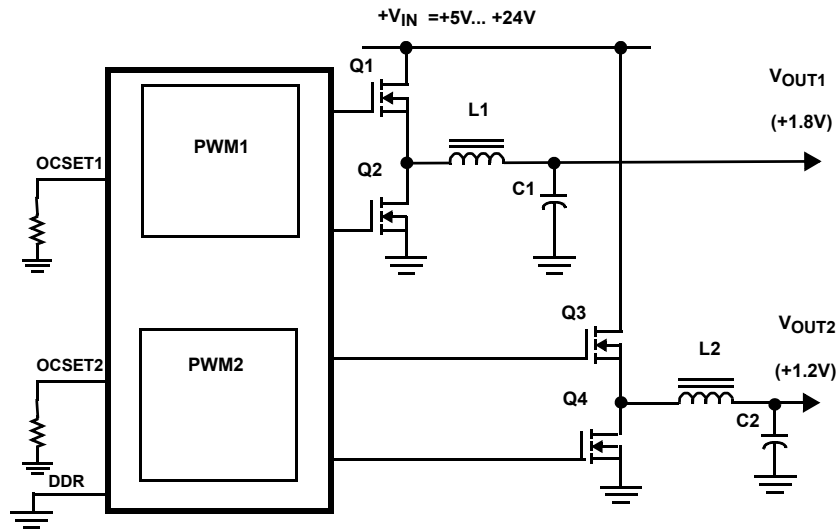

ISL6444 APPLICATION CIRCUIT FOR TWO CHANNEL POWER SUPPLY

Generic Application Circuits (Continued)

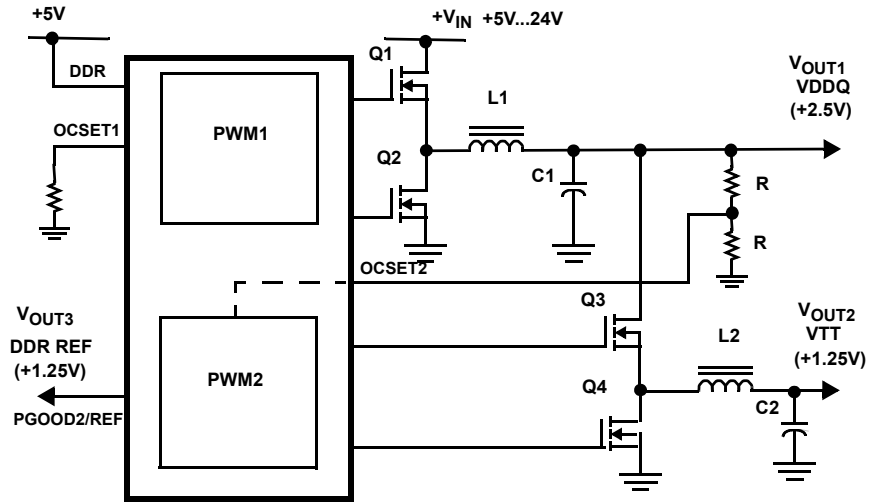

ISL6444 APPLICATION CIRCUIT FOR COMPLETE DDR MEMORY POWER SUPPLY

Absolute Maximum Ratings

Bias Voltage, V_{CC}	+6.5V
Input Voltage, V_{IN}	+27.0V
PHASE, BOOT, ISEN, UGATE	GND -0.3V to +33.0V
BOOT with respect to PHASE	+6.5V
All Other Pins	GND -0.3V to V_{CC} + 0.3V
ESD Classification	Class 2

Thermal Information

Thermal Resistance (Typical, Note 1)	θ_{JA} (°C/W)
QSOP Package	78
Maximum Junction Temperature (Plastic Package)	+125°C
Maximum Storage Temperature Range	-65°C to +150°C
Maximum Lead Temperature (Soldering 10s)	+300°C
(QSOP - Lead Tips Only)	

Recommended Operating Conditions

Bias Voltage, V_{CC}	+5.0V ±5%
Input Voltage, V_{IN}	+5.0V to +24.0V
Ambient Temperature Range	-10°C to +85°C
Junction Temperature Range	-10°C to +125°C

CAUTION: Stresses above those listed in "Absolute Maximum Ratings" may cause permanent damage to the device. This is a stress only rating and operation of the device at these or any other conditions above those indicated in the operational sections of this specification is not implied.

NOTE:

- θ_{JA} is measured with the component mounted on a high effective thermal conductivity test board in free air. See Tech Brief TB379 for details.

Electrical Specifications Recommended Operating Conditions, Unless Otherwise Noted.

PARAMETER	SYMBOL	TEST CONDITIONS	MIN	TYP	MAX	UNITS
VCC SUPPLY						
Bias Current	I_{CC}	LGATEx, UGATEx Open, VSENx forced above regulation point, DDR = 0, $V_{IN} > 5V$	-	2.2	3.2	mA
Shut-Down Current	I_{CCSN}		-	-	30	μA
VCC UVLO						
Rising V_{CC} Threshold	V_{CCU}		4.3	4.65	4.75	V
Falling V_{CC} Threshold	V_{CCD}		4.1	4.35	4.45	V
VIN						
Input Voltage Pin Current (Sink)	I_{VIN}		10	-	30	μA
Input Voltage Pin Current (Source)	I_{VINO}		-	-15	-30	μA
Shut-Down Current	I_{VINS}		-	-	1	μA
OSCILLATOR						
PWM1 Oscillator Frequency	F_C		255	300	345	kHz
Ramp Amplitude, pk-pk	V_{R1}	$V_{IN} = 16V$, by characterization	-	2	-	V
Ramp Amplitude, pk-pk	V_{R2}	$V_{IN} = 5V$, by characterization	-	1.25	-	V
Ramp Offset	V_{ROFF}	By characterization	-	0.5	-	V
Ramp/ V_{IN} Gain	G_{RB1}	$V_{IN} \geq 3V$, by characterization	-	125	-	mV/V
Ramp/ V_{IN} Gain	G_{RB2}	$1 \leq V_{IN} \leq 3V$, by characterization	-	250	-	mV/V
REFERENCE AND SOFT START						
Internal Reference Voltage	V_{REF}		-	0.9	-	V
Reference Voltage Accuracy			-1.0	-	+1.0	%
Soft-Start Current During Start-Up	I_{SOFT}		-	-5	-	μA
Soft-Start Complete Threshold	V_{ST}	By characterization	-	1.5	-	V
PWM CONVERTERS						
Load Regulation		$0.0mA < I_{VOUT1} < 5.0A$; $5.0V < V_{BATT} < 24.0V$	-2.0	-	+2.0	%
VSEN Pin Bias Current	I_{VSEN}	By characterization	50	80	120	nA
VOUT Pin Input Impedance	I_{VOUT}	$V_{OUT} = 5V$	40	55	65	kΩ

Electrical Specifications Recommended Operating Conditions, Unless Otherwise Noted. (Continued)

PARAMETER	SYMBOL	TEST CONDITIONS	MIN	TYP	MAX	UNITS
Undervoltage Shut-Down Level	V _{UVL}	Fraction of the set point; ~2μs noise filter	70	-	85	%
Overvoltage Shut-Down	V _{OVP1}	Fraction of the set point; ~2μs noise filter	110	-	130	%
GATE DRIVERS						
Upper Drive Pull-Up Resistance	R _{2UGPUP}	V _{CC} = 4.5V	-	8	15	Ω
Upper Drive Pull-Down Resistance	R _{2UGPDN}	V _{CC} = 4.5V	-	3.2	5	Ω
Lower Drive Pull-Up Resistance	R _{2LGPUP}	V _{CC} = 4.5V	-	8	15	Ω
Lower Drive Pull-Down Resistance	R _{2LGPDN}	V _{CC} = 4.5V	-	1.8	3	Ω
POWER GOOD AND CONTROL FUNCTIONS						
Power Good Lower Threshold	V _{PG-}	Fraction of the set point; ~3μs noise filter	-13	-	-7	%
Power Good Higher Threshold	V _{PG+}	Fraction of the set point; ~3μs noise filter. Guaranteed by characterization.	12	-	16	%
PGOODx Leakage Current	I _{PGLKG}	V _{PULLUP} = 5.5V	-	-	1	μA
PGOODx Voltage Low	V _{PGOOD}	I _{PGOOD} = -4mA	-	0.5	0.85	V
EN - Low (Off)			-	-	0.8	V
EN - High (On)			2.5	-	-	V
CCM Enforced (Hysteretic Operation Inhibited)		VOUTX pulled low	-	-	0.1	V
Automatic CCM/Hysteretic Operation Enabled		VOUTX connected to the output	0.9	-	-	V
DDR - Low (Off)			-	-	0.8	V
DDR - High (On)			2.5	-	-	V
DDR REF Output Voltage	V _{DDREF}	DDR = 1, I _{REF} = 0...10mA	0.99* V _{OC2}	V _{OC2}	1.01* V _{OC2}	V
DDR REF Output Current	I _{DDREF}	DDR = 1. Guaranteed by characterization.	-	10	16	mA

Block Diagram

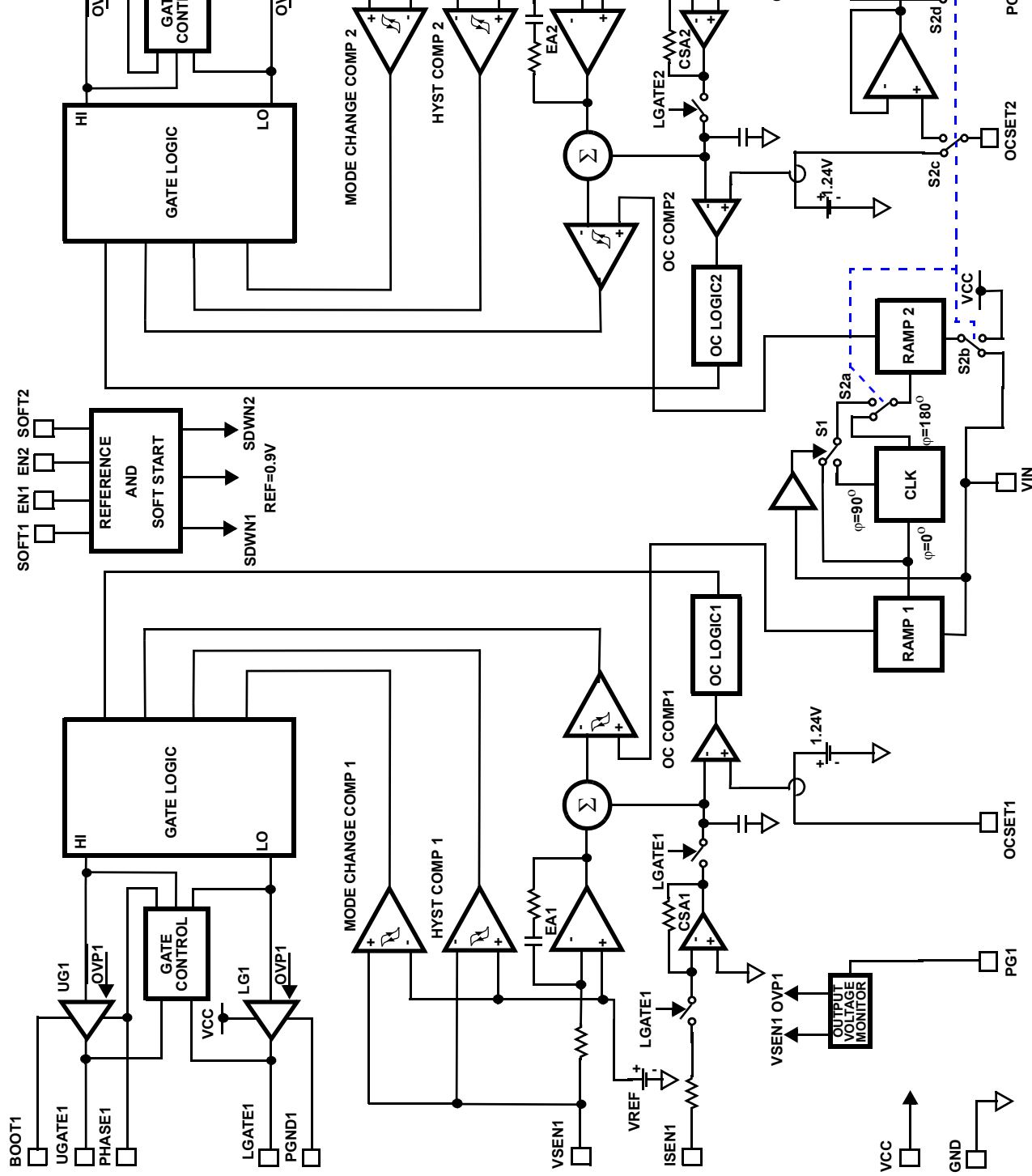

Functional Pin Description

GND (Pin 1)

Signal ground for the IC.

LGATE1, LGATE2 (Pin 2, 27)

These are outputs of the lower MOSFET drivers.

PGND1, PGND2 (Pin 3, 26)

These pins provide the return connection for lower gate drivers. These pins are connected to sources of the lower MOSFETs of their respective converters.

PHASE1, PHASE2 (Pin 4, 25)

The PHASE1 and PHASE2 points are the junction points of the upper MOSFET sources, output filter inductors, and lower MOSFET drains. Connect these pins to the respective converter's upper MOSFET source.

UGATE1, UGATE2 (Pin 5, 24)

These pins provide the gate drive for the upper MOSFETs.

BOOT1, BOOT2 (Pin 6, 23)

These pins power the upper MOSFET drivers of the PWM converter. Connect this pin to the junction of the bootstrap capacitor with the cathode of the bootstrap diode. Anode of the bootstrap diode is connected to the VCC pin.

ISEN1, ISEN2 (Pin 7, 22)

These pins are used to monitor the voltage drop across the lower MOSFET for current feedback and overcurrent protection. For precise current detection these inputs can be connected to the optional current sense resistors placed in series with the source of the lower MOSFETs.

EN1, EN2 (Pin 8, 21)

These pins enable operation of the respective converter when high. When both pins are low, the chip is disabled and only low leakage current $<1\mu\text{A}$ is taken from VCC and VIN.

VOUT1, VOUT2 (Pin 9, 20)

These pins when connected to the converters' respective outputs provide the output voltage inside the chip to reduce output voltage excursion during HYS/PWM transition. When connected to ground, the se pins command forced converters operate in continuous conduction mode at all load levels.

VSEN1, VSEN2 (Pin 10, 19)

These pins are connected to the resistive dividers that set the desired output voltage. The PGOOD, UVP, and OVP circuits use this signal to report output voltage status.

OCSET1 (Pin 11)

A resistor from this pin to ground sets the over current threshold for the first controller.

SOFT1, SOFT2 (Pin 12, 17)

These pins provide soft-start function for their respective controllers. When the chip is enabled, the regulated $5\mu\text{A}$ pull-up current source charges the capacitor connected from the pin to ground. The output voltage of the converter follows the ramping voltage on the SOFT pin.

DDR (Pin 13)

This pin, when high, transforms dual channel chip into complete DDR memory solution. The OCSET2 pin becomes an input to provide the required tracking function. The channel synchronization is changed from out-of-phase to in-phase. The PG2/REF pin becomes the output of the VDDQ/2 buffered voltage that is used as a reference voltage by the second channel.

VIN (Pin 14)

Provides battery voltage to the oscillator for feed-forward rejection of the input voltage variation.

When connected to ground via $100\text{k}\Omega$ resistor while the DDR pin is high, this pin commands the out-of-phase 90° channels synchronization for reduces inter-channel interference.

PG1 (Pin 15)

PGOOD1 is an open drain output used to indicate the status of the output voltage. This pin is pulled low when the first channel output is not within $\pm 10\%$ of the set value.

PG2/REF (Pin 16)

This pin has a double function depending on the mode the chip is operating. When the chip is used as a dual channel PWM controller (DDR = 0), the pin provides a PGOOD2 function for the second channel. The pin is pulled low when the second channel output is not within $\pm 10\%$ of the set value.

In DDR mode (DDR = 1), this pin serves as an output of the buffer amplifier that provides VDDQ/2 reference voltage applied to the OCSET2 pin.

OCSET2 (Pin 18)

In a dual channel application (DDR = 0), a resistor from this pin to ground sets the over current threshold for the second controller.

In the DDR application (DDR = 1), this pin sets the output voltage of the buffer amplifier and the second controller and should be connected to the center point of a divider from the VDDQ output.

VCC (Pin 28)

This pin powers the controller.

Description

Operation

The ISL6444 is a dual channel PWM controller intended for use in power supplies for graphic chipset, SDRAM, DDR DRAM or other low voltage power applications in modern notebook and sub-notebook PCs. The IC integrates two control circuits for two synchronous buck converters. The output voltage of each controller can be set in the range of 0.9V to 5.5V by an external resistive divider. Out-of-phase operation with 180° phase shift reduces input current ripple.

The synchronous buck converters can operate from either an unregulated DC source such as a notebook battery with a voltage ranging from 5.0V to 24V, or from a regulated system rail of 3.3V or 5V. In either mode of operation, the controller is biased from the +5V source.

The controllers operate in the current mode with input voltage feed-forward for simplified feedback loop compensation and reduced effect of the input voltage variation. An integrated feedback loop compensation dramatically reduces the number of external components.

Depending on the load level, converters can operate either in a fixed-frequency mode or in a hysteretic mode. Switch-over to the hysteretic mode operation at light loads improves the converters' efficiency and prolongs battery run time. The hysteretic mode of operation can be inhibited independently for each channel if a variable frequency operation is not desired.

The ISL6444 has a special means to rearrange its internal architecture into a complete DDR solution. When DDR input is set high, the second channel can provide the capability to track the output voltage of the first channel. The buffered reference voltage required by DDR memory chips is also provided.

Initialization

The ISL6444 initializes if at least one of the enable pins is set high. The Power-On Reset (POR) function continually monitors the bias supply voltage on the VCC pin and initiates soft-start operation after the input supply voltage exceeds 4.5V. Should this voltage drop lower than 4.0V, the POR disables the chip.

Soft-Start

When soft start is initiated, the voltage on the SOFT pin of the enabled channel starts to ramp gradually due to the 5 μ A current sourced into the external soft-start capacitor. The output voltage starts to follow the soft-start voltage.

When the SOFT pin voltage reaches a level of 0.9V, the output voltage comes into regulation while the soft-start pin voltage continues to rise. When the SOFT voltage reaches

1.5V, the power good (PGOOD), the mode control, and the fault functions are enabled, as depicted in Figure 1.

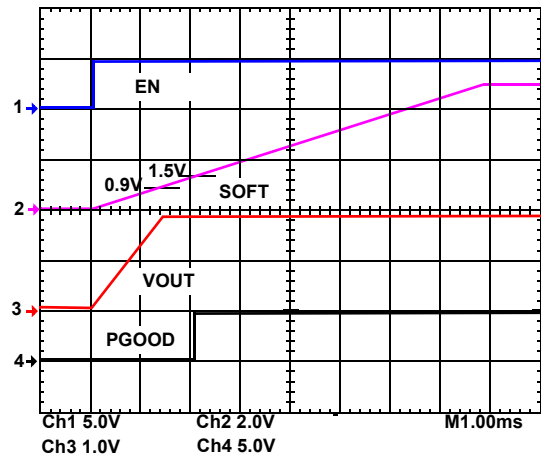

FIGURE 1. START-UP

This completes the soft start sequence. Further rise of pin voltage does not affect the output voltage. During the soft-start, the converter always operates in continuous conduction mode independently of the load level or FCCM pin potential.

The soft-start time (the time from the moment when EN becomes high to the moment when PGOOD is reported) is determined by Equation 1.

$$T_{\text{SOFT}} = \frac{1.5V \times C_{\text{soft}}}{5\mu\text{A}} \quad (\text{EQ. 1})$$

The time it takes the output voltage to come into regulation can be obtained from Equation 2.

$$T_{\text{RISE}} = 0.6 \times T_{\text{SOFT}} \quad (\text{EQ. 2})$$

Having such a spread between the time when the output voltage reaches the regulation point and the moment when PGOOD is reported allows for a fault-safe test mode by means of an external circuit that clamps the SOFT pin voltage on the level $0.9V < V_{\text{SOFT}} < 1.5V$.

Output Voltage Program

The output voltage of either channel is set by a resistive divider from the output to ground. The center point of the divider is connected to VSEN pin as shown in Figure 2. The output voltage value is determined by Equation 3.

$$V_O = \frac{0.9V \cdot (R1 + R2)}{R2} \quad (\text{EQ. 3})$$

Where 0.9V is the value of the internal reference. The VSEN pin voltage is also used by the controller for the power good function and to detect undervoltage and overvoltage conditions.

Automatic Operation Mode Control

In nominal currents the synchronous buck converter operates in continuous-conduction constant-frequency mode. This mode of operation achieves higher efficiency due to the substantially lower voltage drop across the

synchronous MOSFET compared to a Shottky diode. In contrast, continuous-conduction operation in load currents lower than the inductor critical value results in lower efficiency. In this case, during a fraction of a switching cycle, the direction of the inductor current changes to the opposite actively discharging the output filter capacitor.

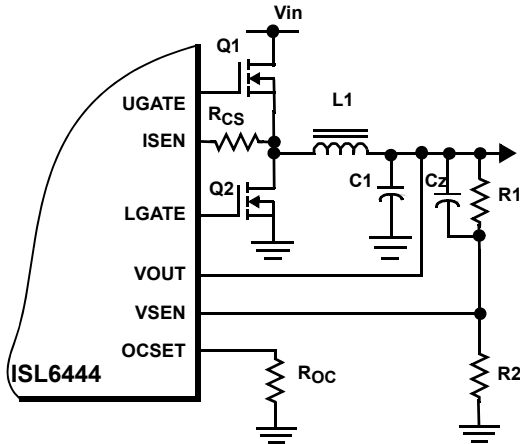

FIGURE 2. OUTPUT VOLTAGE PROGRAM

To maintain the output voltage in regulation, the discharged energy should be restored during the consequent cycle of operation by the cost of increased circulating current and losses associated with it.

The critical value of the inductor current can be estimated by the following expression.

$$I_{HYS} = \frac{(V_{IN} - V_O) \cdot V_O}{2 \cdot F_{SW} \cdot L_O \cdot V_{IN}} \quad (EQ. 4)$$

To improve converter efficiency in loads lower than critical, the switch-over to variable frequency hysteretic operation with diode emulation is implemented into the PWM scheme. The switch-over is provided automatically by the mode control circuit that constantly monitors the inductor current and alters the way the PWM signal is generated.

The voltage across the synchronous MOSFET at the moment of time just before the upper-MOSFET turns on is monitored for purposes of mode change. When the converter operates in currents higher than critical, this voltage is always positive as shown in Figure 3 and 4. In currents lower than critical, the voltage is always negative. The mode control circuit uses a sign of voltage across the synchronous devices to determine if the load current is higher or lower than the critical value.

To prevent chatter between operating modes, the circuit looks for eight sequential matching sign signals before it makes its decision to perform a mode change. The same algorithm is true for both CCM-hysteretic and hysteretic-CCM transitions.

Hysteretic Operation

When the critical inductor current is detected, the converter enters hysteretic mode. The PWM comparator and the error amplifier that provided control in the CCM mode are inhibited and the hysteretic comparator is now activated. A change is also made to the gate logic. In hysteretic mode the synchronous rectifier MOSFET is controlled in diode emulation mode, hence conduction in the second quadrant is prohibited.

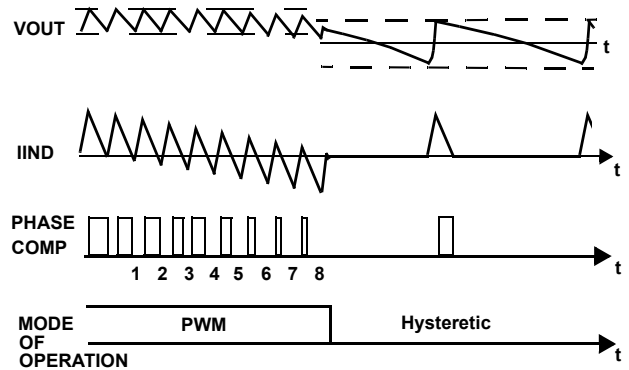

FIGURE 3. CCM -- HYSTERETIC TRANSITION

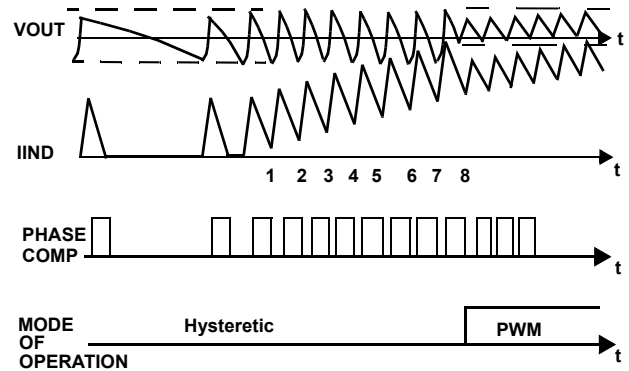

FIGURE 4. HYSTERETIC -- CCM TRANSITION

The hysteretic comparator initiates the PWM signal when the output voltage gets below the lower threshold and terminates the PWM signal when the output voltage rises over the upper threshold. A spread or hysteresis between these two thresholds determines the switching frequency and the peak value of the inductor current. A transition to a constant frequency CCM mode will happen when the load current gets to a level higher than the critical:

$$I_{CCM} \approx \frac{\Delta V_{hys}}{2 \cdot ESR} \quad (EQ. 5)$$

Where, $\Delta V_{hys} = 15mV$, is a hysteretic comparator window, ESR is the equivalent series resistance of the output capacitor.

Because of different control mechanisms, the value of the load current where transition into CCM operation takes place

is usually higher compared to the load level at which transition into hysteretic mode had occurred.

VOUT pin and Forced Continuous Conduction Mode (FCCM)

The error amplifier that provides control over the converter during CCM mode is excluded from the regulation loop in the hysteretic mode. Due to that, its output voltage eventually runs away from the operation point that is normally related to the desired output voltage. When the converter transitions from hysteretic mode of operation into CCM, the output voltage transient can occur as it takes some time for the error amplifier to catch-up with regulation.

To reduce undesirable effects of the error amplifier run away during mode change, the exact value of the output voltage is provided to the internal circuit via the VOUT pin, Figure 2.

In case the hysteretic mode of operation is not required, the controller can be put in a forced continuous conduction mode (FCCM) of operation. That can be accomplished by connecting the VOUT pin to ground, which disables the mode control circuit.

Such dual function of the VOUT pin enhances applicability of the controller and allows for lower pin count.

Feedback Loop Compensation

To reduce the number of external components and remove the burden of determining compensation components from a system designer, both PWM controllers have internally compensated error amplifiers. To make internal compensation possible several design measures were taken.

First, the ramp signal applied to the PWM comparator is proportional to the input voltage provided via the VIN pin. This keeps the modulator gain constant when the input voltage varies. The second, the load current proportional signal is derived from the voltage drop across the lower MOSFET during the PWM time interval and is added to the amplified error signal on the comparator input. This effectively creates an internal current control loop. The resistor connected to the ISEN pin sets the gain in the current feedback loop. Equation 6 estimates the required value of the current sense resistor depending on the maximum load current and the value of the MOSFET's $r_{DS(ON)}$.

$$R_{CS} = \frac{I_{MAX} \cdot r_{DS(ON)}}{75\mu A} - 100\Omega \quad (EQ. 6)$$

Due to implemented current feedback, the modulator has a single pole response with -1 slope at a frequency determined by the load in Equation 7.

where: R_o -- is load resistance and C_o -- is load capacitance.

$$F_{PO} = \frac{1}{2\pi \cdot R_o \cdot C_o} \quad (EQ. 7)$$

For this type of modulator, a Type 2 compensation circuit is usually sufficient.

Figure 5 shows a Type 2 amplifier and its response along with the responses of the current mode modulator and the converter. The Type 2 amplifier, in addition to the pole at origin, has a zero-pole pair that causes a flat gain region at frequencies in between the zero and the pole.;

$$F_Z = \frac{1}{2\pi \cdot R_2 \cdot C_1} = 6kHz \quad (EQ. 8)$$

$$F_P = \frac{1}{2\pi \cdot R_1 \cdot C_2} = 600kHz \quad (EQ. 9)$$

This region is also associated with phase 'bump' or reduced phase shift. The amount of phase shift reduction depends on how wide the region of flat gain is and has a maximum value of 90°. To further simplify the converter compensation, the modulator gain is kept independent of the input voltage variation by providing feed-forward of V_{IN} to the oscillator ramp.

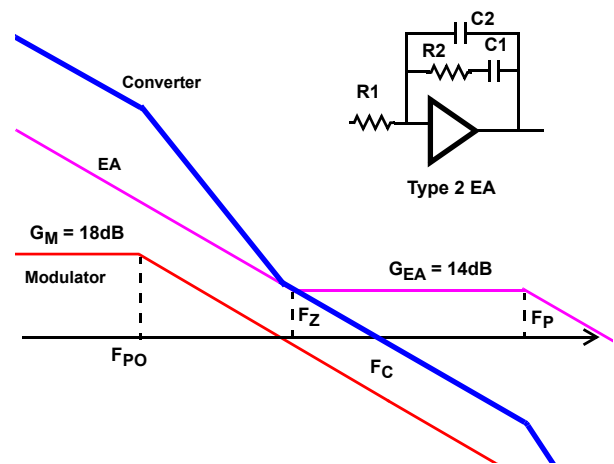

FIGURE 5. FEEDBACK LOOP COMPENSATION

The zero frequency, the amplifier high-frequency gain, and the modulator gain are chosen to satisfy most typical applications. The crossover frequency will appear at the point where the modulator attenuation equals the amplifier high frequency gain. The only task that the system designer has to complete is to specify the output filter capacitors to position the load main pole somewhere within one decade lower than the amplifier zero frequency. With this type of compensation plenty of phase margin is easily achieved due to zero-pole pair phase 'boost'.

Conditional stability may occur only when the main load pole is positioned too much to the left side on the frequency axis due to excessive output filter capacitance. In this case, the ESR zero placed within 10kHz...50kHz range gives some additional phase 'boost'. Some phase boost can also be achieved by connecting capacitor C_2 in parallel with the upper resistor R_1 of the divider that sets the output voltage value, as shown in Figure 2.

Gate Control Logic

The gate control logic translates generated PWM signals into gate drive signals providing necessary amplification, level shift, and shoot-through protection. Also, it bears some functions that help to optimize the IC performance over a wide range of the operational conditions. As MOSFET switching time can vary dramatically from type to type and with the input voltage, the gate control logic provides adaptive dead time by monitoring real gate waveforms of both the upper and the lower MOSFETs.

Dual-Step Conversion

The ISL6444 dual channel controller can be used either in power systems with a single-stage power conversion when the battery power is converted into the desired output voltage in one step, or in the systems where some intermediate voltages are initially established. The choice of the approach may be dictated by the overall system design criteria or simply to be a matter of voltages available to the system designer, like in the case of PCI card applications.

When the power input voltage is a regulated 5V or 3.3V system bus, the feed-forward ramp may become too shallow, which creates the possibility of duty-factor jitter especially in a noisy environment. The noise susceptibility when operating from low level regulated power sources can be improved by connecting the VIN pin to ground via a resistor. The internal pull-up current source of $\sim 15\mu\text{A}$ will create a voltage drop across the resistor. If this voltage is lower than 2.5V, the feed-forward ramp generator will be internally reconnected from the VIN pin to the VCC pin and the ramp slew rate will be doubled. Application circuits for dual-step power conversion are presented in Figure 10.

Protections

The converter output is monitored and protected against extreme overload, short circuit, overvoltage, and undervoltage conditions.

A sustained overload on the output sets the PGOOD low and latches-off the whole chip. The controller operation can be restored by cycling the VCC voltage or an enable (EN) pin.

Overcurrent Protection

Both PWM controllers use the lower MOSFET's on-resistance $r_{\text{DS(ON)}}$ to monitor the current for protection against shorted outputs. The sensed current from the ISEN pin is compared with a current set by a resistor connected from the OCSET pin to ground.

$$R_{\text{OCSET}} = \frac{11.2\text{V} \cdot (R_{\text{CS}} + 100\Omega)}{I_{\text{OC}} \cdot R_{\text{DS(ON)}}}$$

Where, I_{OC} is a desired overcurrent protection threshold and R_{CS} is the value of the current sense resistor connected to the ISEN pin.

If the lower MOSFET current exceeds the overcurrent threshold, a pulse skipping circuit is activated. The upper MOSFET will not be turned on as long as the sensed current is higher than the threshold value. This limits the current supplied by the DC voltage source. This condition keeps on for eight clock cycles after the overcurrent comparator was tripped for the first time. If after these first eight clock cycles, the current exceeds the overcurrent threshold again in a time interval of another eight clock cycles, the overcurrent protection latches and disables the chip. If the overcurrent condition goes away during the first eight clock cycles, normal operation is restored and the overcurrent circuit resets itself sixteen clock cycles after the overcurrent threshold was exceeded the first time, Figure 6.

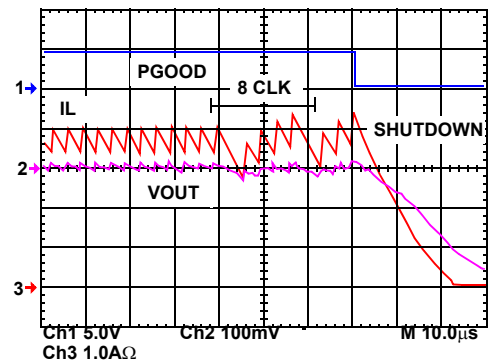

FIGURE 6. OVERCURRENT PROTECTION WAVEFORMS

If load step is strong enough to pull output voltage lower than the undervoltage threshold, the chip shuts down immediately.

Because of the nature of the used current sensing technique, and to accommodate wide range of the $r_{\text{DS(ON)}}$ variation, the value of the overcurrent threshold should represent overload current about 150%...180% of the nominal value. If accurate current protection is desired, a current sense resistor placed in series with the lower MOSFET source may be used.

Overvoltage Protection

Should the output voltage increase over 115% of the normal value due to the upper MOSFET failure, or other reasons, the overvoltage protection comparator will force the synchronous rectifier gate driver high. This action actively pulls down the output voltage and eventually attempts to blow the battery fuse. As soon as the output voltage drops below the threshold, the OVP comparator is disengaged.

This OVP scheme provides a 'soft' crowbar function which helps to tackle severe load transients and does not invert the output voltage when activated -- a common problem for OVP schemes with a latch.

Overtemperature Protection

The chip incorporates an over temperature protection circuit that shuts the chip down when the die temperature of +150°C is reached. Normal operation restores at die temperatures below +125°C through the full soft-start cycle.

DDR Application

Double Data Rate (DDR) memory chips are expected to take a place of memory of choice in many newly designed computers including high-end notebooks due to increased throughput. A novelty feature associated with this type of memory is new referencing and data bus termination techniques. These techniques employ a reference voltage, VREF, that tracks the center point of VDDQ and VSS voltages and an additional VTT power source to which all terminating resistors are connected. Despite the additional power source, the overall memory power consumption is reduced compared to traditional termination.

The added power source has a cluster of requirements that should be observed and considered. Due to reduced differential thresholds of DDR memory, the termination power supply voltage, VTT, shall closely track VDDQ/2 voltage. Another very important feature for the termination power supply is a capability to equally operate in sourcing and sinking modes. The VTT supply shall regulate the output voltage with the same degree of precision when current is floating from the supply to the load and when the current is diverted back from the load into the power supply. The last mode of operation usually conflicts with the way most PWM controllers operate.

The ISL6444 dual channel PWM controller possesses several important means that allow re configuration for this particular application and provide all three voltages required in DDR memory compliant computer.

To reconfigure the ISL6444 for a complete DDR solution, the DDR pin shall be permanently set high. The simplest way to do that is to connect it to the VCC rail. This activates some functions inside the chip that are specific to the DDR memory power needs.

In DDR application presented in Figure 12, the first controller regulates VDDQ rail to 2.5V. The output voltage is set by an external divider R3 and R4. The second controller regulates the VTT rail to VDDQ/2. The OCSET2 pin function is now different. The pin serves now as an input that brings VDDQ/2 voltage created by R5 and R6 divider inside the chip. That effectively provides a tracking function for the VTT voltage.

The PG2 pin function is also different in DDR mode. This pin becomes the output of the buffer, which input is connected via the OCSET2 pin to the center point of the R/R divider from the VDDQ output. The buffer output voltage serves as 1.25V reference for the DDR memory chips. Current capability of this pin is about 10mA.

For the VTT channel some control and protective functions can be significantly simplified as this output is derived from the VDDQ output. For example, the overcurrent and overvoltage protections for the second controller are disabled when the DDR pin is set high. The hysteretic mode of operation is also disabled on the VTT channel to allow sinking capability to be independent from the load level. As the VTT channel tracks the VDDQ/2 voltage, the soft-start function is not required and the SOFT2 pin may be left open or may be connected to VCC.

Channel Synchronization in DDR Applications

Presence of two PWM controllers on the same die require channel synchronization to reduce inter channel interference that may cause the duty factor jitter and increased output ripple. The PWM controller is mostly susceptible to noise when an error signal on the input of the PWM comparator approaches the decision making point. False triggering can occur causing jitter and affecting the output regulation.

Out-of-phase operation is a common approach to synchronize dual channel converters as it reduces an input current ripple and provides a minimum interference for channels that control different voltage levels. When used in DDR application with cascaded converters (VTT generated from VDDQ), the turn-on of the upper MOSFET in the VDDQ channel happens to be just before the decision making point in the VTT channel that is running with a duty-factor close to 50%, Figure 7 and Figure 8. This makes out-of-phase channel synchronization undesirable when one of the channels is running on a duty-factor of 50%. Inversely, the in-phase channel arrangement does not have this drawback. Points of decision are far from noisy moments of time in both sourcing and sinking modes of operation for $V_{IN} = 7.5V$ to 24V as it is shown in Figure 7.

In the case when power for VDDQ is taken from the +5V system rail, as Figure 8 shows, both in-phase and out-of-phase approaches are susceptible to noise in the sourcing mode.

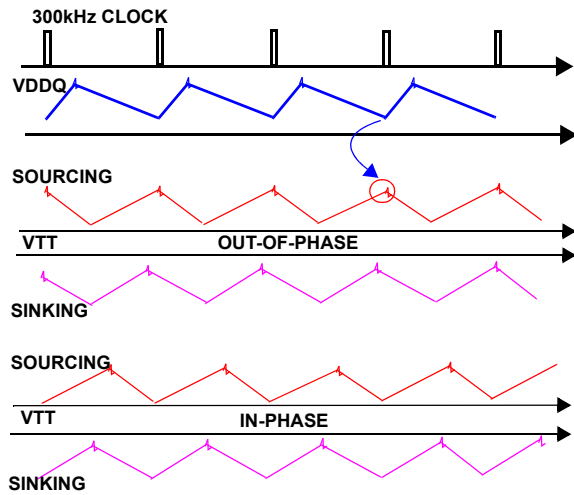

FIGURE 7. CHANNEL INTERFERENCE VIN = 7.5V...24V

Noise immunity can be improved by operating the VTT converter with a 90° phase shift. As the time diagrams in Figure 8 show, the points of concern are always about a quarter of the period away from the noise emitting transitions.

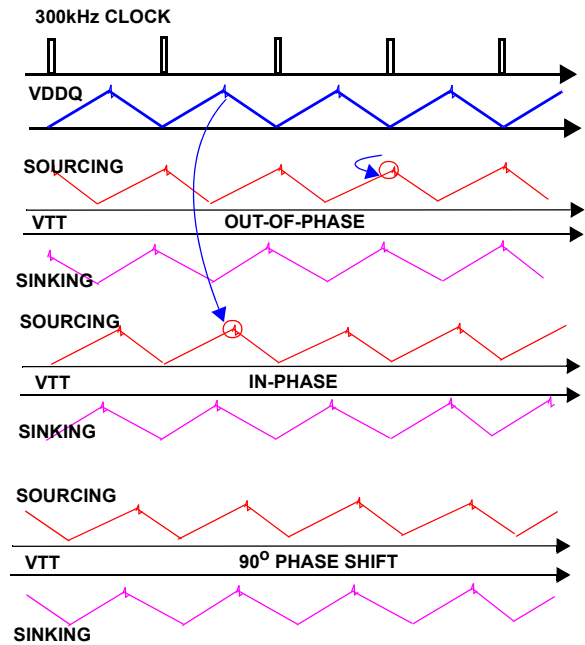

FIGURE 8. CHANNEL INTERFERENCE VIN = 5V

Several ways of synchronization are implemented into the chip. When the DDR pin is connected to GND, the channels operate 180° out-of-phase. In the DDR mode when the DDR pin is connected to VCC, the channels operate either in-phase when the VIN pin is connected to the input voltage source, or with 90° phase shift if the VIN pin is connected to GND via the 100kΩ resistor.

ISL6444 DC/DC Converter Application Circuits

Figures 9 and 10 show application circuits of a dual channel DC/DC converter for a notebook PC.

The power supply in Figure 9 provides +V2.5S and +V1.8S voltages for memory and graphic interface chipset from +5.0V to +24VDC battery voltage.

Figure 10 shows the power supply that provides +V2.5S and +V1.8S voltages for memory and graphic interface chipset from +5.0V system rail.

Figure 11 shows an application circuit for a single-output split input power supply with current sharing for advanced graphic card applications.

Figure 12 and 13 show application circuits of a complete power solution for DDR memory that becomes a preferred choice in modern computers.

The power supply shown in Figure 12 generates +2.5V VDDQ voltage from a battery. The +1.25V VTT termination voltage tracks VDDQ/2 and is derived from +2.5V VDDQ. To complete the DDR memory power requirements, the +1.25V reference voltage is also provided. The PG2 pin serves as an output for the reference voltage in this mode.

Figure 13 depicts the DDR solution in the case where the 5V system rail is used as a primary voltage source.

For detailed information on the circuit, including a Bill-of-Materials and circuit board description, see Application Note AN9995. Also see Intersil's web site (www.intersil.com) for the latest information.

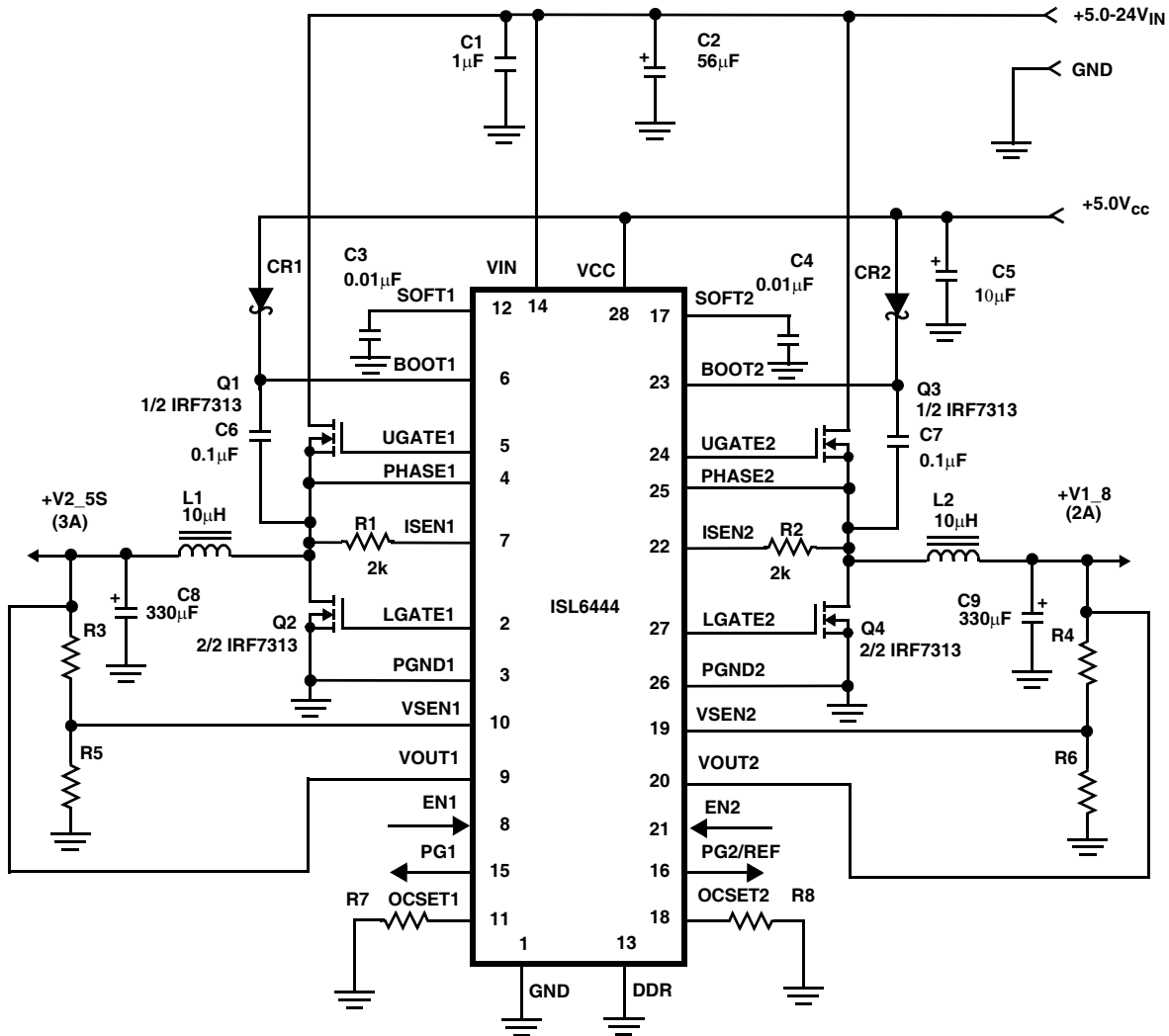

FIGURE 9. DUAL OUTPUT APPLICATION CIRCUIT FOR ONE-STEP CONVERSION

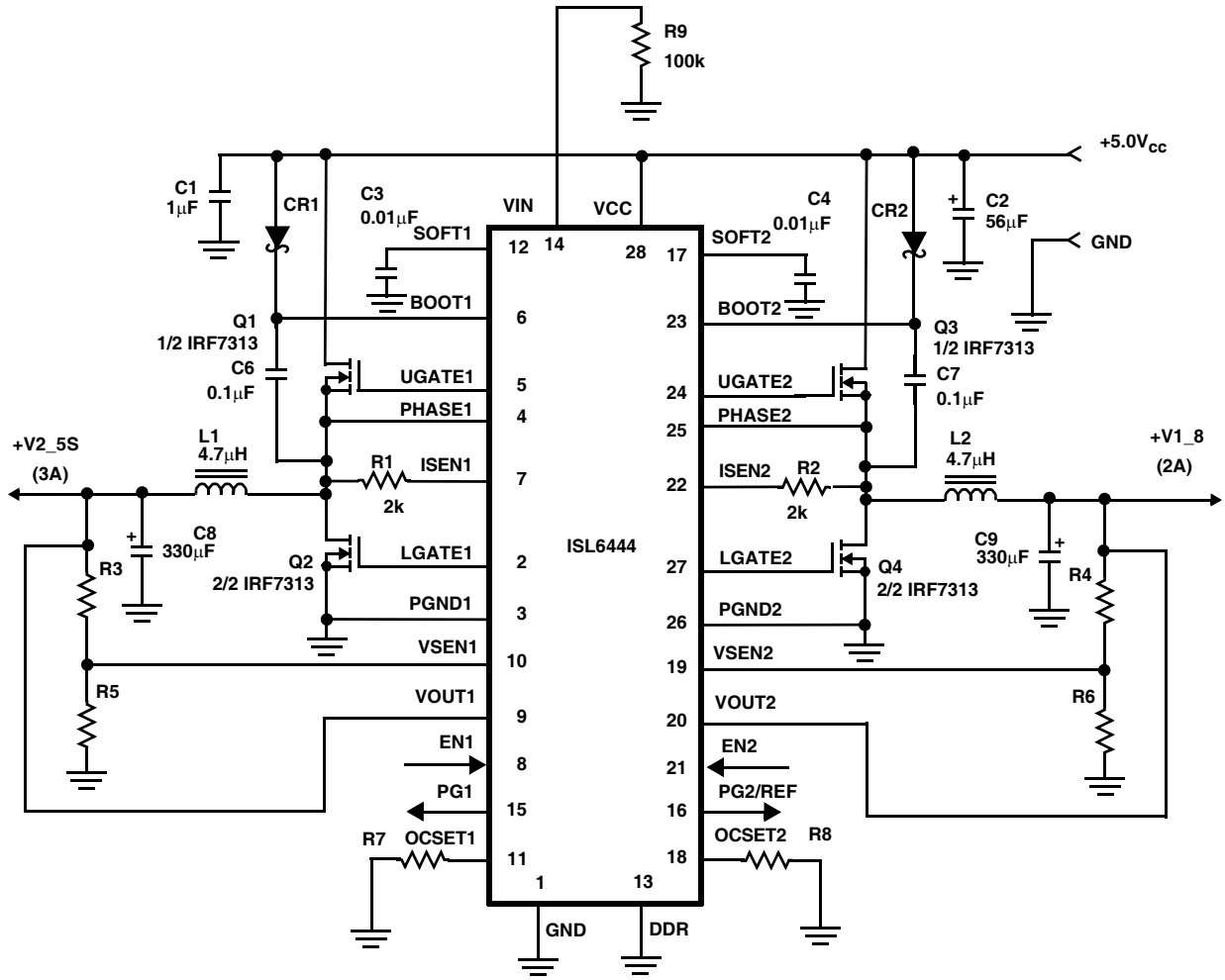

FIGURE 10. DUAL OUTPUT APPLICATION CIRCUIT FOR TWO-STEP CONVERSION

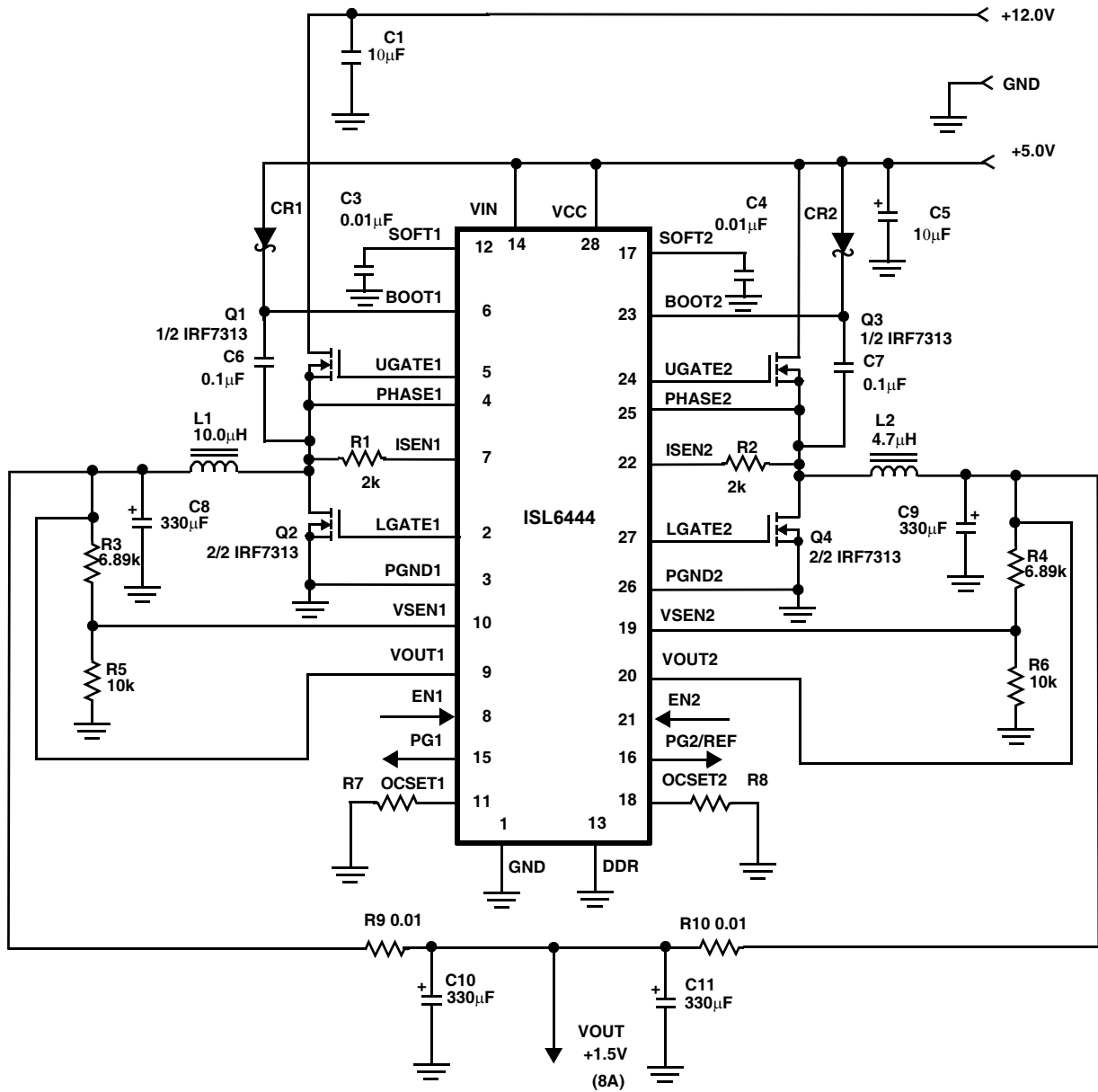

FIGURE 11. SINGLE-OUTPUT SPLIT INPUT POWER SUPPLY

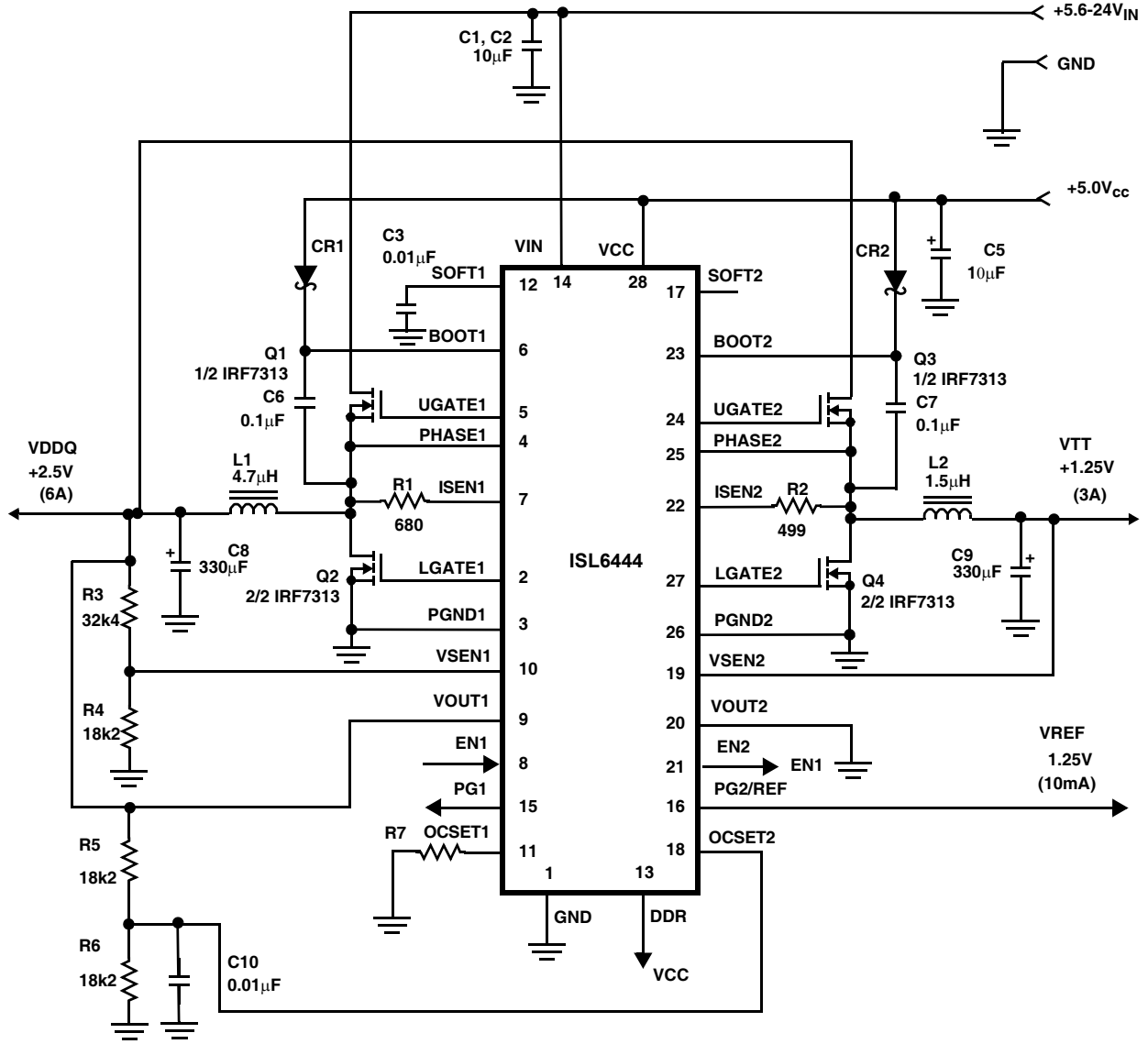

FIGURE 12. APPLICATION CIRCUIT FOR COMPLETE DDR MEMORY POWER SOLUTION WITH ONE-STEP CONVERSION

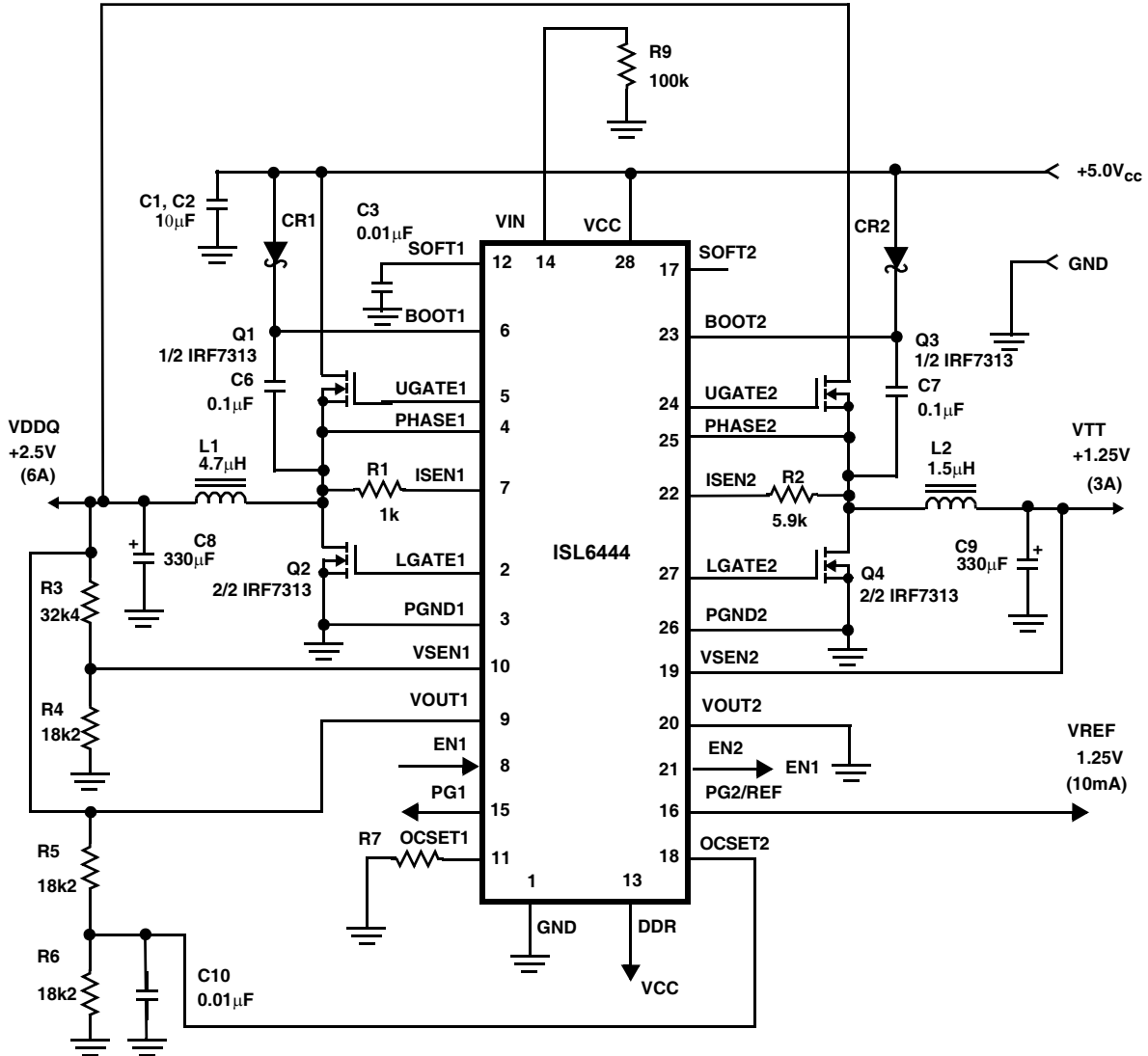

FIGURE 13. APPLICATION CIRCUIT FOR COMPLETE DDR MEMORY POWER SOLUTION WITH TWO-STEP CONVERSION

© Copyright Intersil Americas LLC 2002-2015. All Rights Reserved.
 All trademarks and registered trademarks are the property of their respective owners.

For additional products, see www.intersil.com/en/products.html

Intersil products are manufactured, assembled and tested utilizing ISO9001 quality systems as noted in the quality certifications found at www.intersil.com/en/support/qualandreliability.html

Intersil products are sold by description only. Intersil may modify the circuit design and/or specifications of products at any time without notice, provided that such modification does not, in Intersil's sole judgment, affect the form, fit or function of the product. Accordingly, the reader is cautioned to verify that datasheets are current before placing orders. Information furnished by Intersil is believed to be accurate and reliable. However, no responsibility is assumed by Intersil or its subsidiaries for its use; nor for any infringements of patents or other rights of third parties which may result from its use. No license is granted by implication or otherwise under any patent or patent rights of Intersil or its subsidiaries.

For information regarding Intersil Corporation and its products, see www.intersil.com

**Shrink Small Outline Plastic Packages (SSOP)
Quarter Size Outline Plastic Packages (QSOP)**

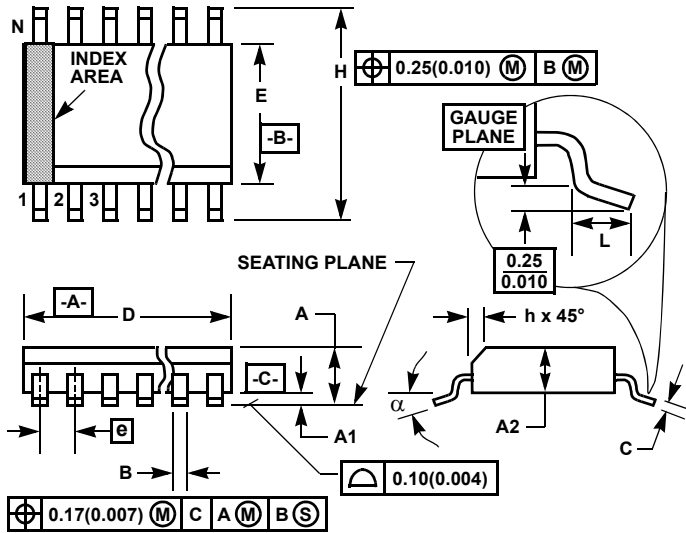

NOTES:

1. Symbols are defined in the "MO Series Symbol List" in Section 2.2 of Publication Number 95.
2. Dimensioning and tolerancing per ANSI Y14.5M-1982.
3. Dimension "D" does not include mold flash, protrusions or gate burrs. Mold flash, protrusion and gate burrs shall not exceed 0.15mm (0.006 inch) per side.
4. Dimension "E" does not include interlead flash or protrusions. Interlead flash and protrusions shall not exceed 0.25mm (0.010 inch) per side.
5. The chamfer on the body is optional. If it is not present, a visual index feature must be located within the crosshatched area.
6. "L" is the length of terminal for soldering to a substrate.
7. "N" is the number of terminal positions.
8. Terminal numbers are shown for reference only.
9. Dimension "B" does not include dambar protrusion. Allowable dambar protrusion shall be 0.10mm (0.004 inch) total in excess of "B" dimension at maximum material condition.
10. Controlling dimension: INCHES. Converted millimeter dimensions are not necessarily exact.

M28.15

**28 LEAD SHRINK SMALL OUTLINE PLASTIC PACKAGE
(0.150" WIDE BODY)**

SYMBOL	INCHES		MILLIMETERS		NOTES
	MIN	MAX	MIN	MAX	
A	0.053	0.069	1.35	1.75	-
A1	0.004	0.010	0.10	0.25	-
A2	-	0.061	-	1.54	-
B	0.008	0.012	0.20	0.30	9
C	0.007	0.010	0.18	0.25	-
D	0.386	0.394	9.81	10.00	3
E	0.150	0.157	3.81	3.98	4
e	0.025 BSC		0.635 BSC		-
H	0.228	0.244	5.80	6.19	-
h	0.0099	0.0196	0.26	0.49	5
L	0.016	0.050	0.41	1.27	6
N	28		28		7
α	0°	8°	0°	8°	-

Rev. 1 6/04

Looking for pricing, stock, or lifecycle information?

Click below to explore more details on WIN SOURCE:

 [View ISL6444CA on WIN SOURCE](#)

 [Intersil Information](#)

Optimize Your Supply Chain with WIN SOURCE Solutions

-  Global Sourcing Solution
-  Obsolete Management
-  Cost Control Management
-  Shortage Management
-  Alternative Solution
-  Excess Inventory Management