



**THE DATASHEET OF  
ISL8120CRZ-T**



ISL8120

Dual/n-Phase Buck PWM Controller with Integrated Drivers

FN6641  
Rev.3.00  
July 20, 2016

The [ISL8120](#) integrates two voltage-mode PWM leading-edge modulation control, with input feed-forward synchronous buck PWM controllers, to control a dual independent voltage regulator or a 2-phase single output regulator. It also integrates current sharing control for the power module to operate in parallel, which offers high system flexibility.

The ISL8120 integrates an internal linear regulator, which generates VCC from input rail for applications with only one single supply rail. The internal oscillator is adjustable from 150kHz to 1.5MHz, and is able to synchronize to an external clock signal for frequency synchronization and phase paralleling applications. Its PLL circuit can output a phase-shift programmable clock signal for the system to be expanded to 3-, 4-, 6-, 12- phases with desired interleaving phase shift.

The ISL8120's Fault Hand Shake feature protects any channel from overloading/stressing due to system faults or phase failure. The undervoltage fault protection features are also designed to prevent a negative transient on the output voltage during falling down. This eliminates the Schottky diode that is used in some systems for protecting the load device from reversed output voltage damage.

**Related Literature**

- Technical Brief [TB389](#) "PCB Land Pattern Design and Surface Mount Guidelines for QFN (MLFP) Packages"
- [AN1528](#), "ISL8120EVAL3Z Evaluation Board Setup Procedure"
- [AN1607](#), "ISL8120EVAL4Z Evaluation Board Setup Procedure"

**Features**

- Wide  $V_{IN}$  range operation: 3V to 22V
  - $V_{CC}$  operation from 3V to 5.60V
- Excellent output voltage regulation:  $0.6V \pm 0.6\% / \pm 0.9\%$  internal reference over commercial/industrial temperature
- Frequency synchronization
- Programmable phase shift for 1-, 2-, 3-, 4-, 6-, up to 12-phase applications
- Fault hand shake capability for high system reliability
- Digital soft-start with precharged output start-up capability
- Dual independent channel enable inputs with precision voltage monitor and voltage feed-forward capability
  - Programmable input voltage POR and its hysteresis with a resistor divider at EN input
- Extensive circuit protection functions: output overvoltage, undervoltage, overcurrent protection, over temperature and pre-power-on reset overvoltage protection option

**Applications**

- Power supply for datacom/telecom and POL
- Paralleling power module
- Wide and narrow input voltage range buck regulators
- DDR I and II applications
- High current density power supplies
- Multiple outputs VRM and VRD

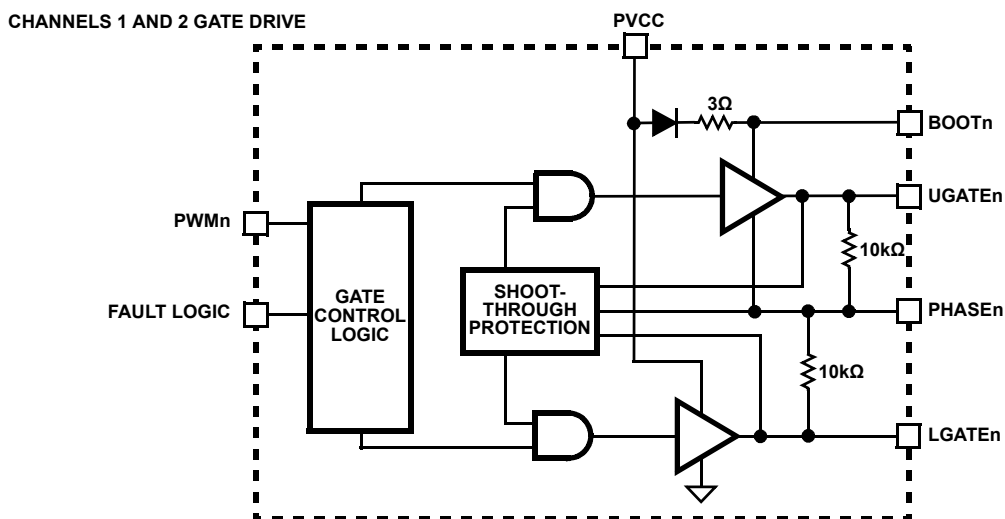
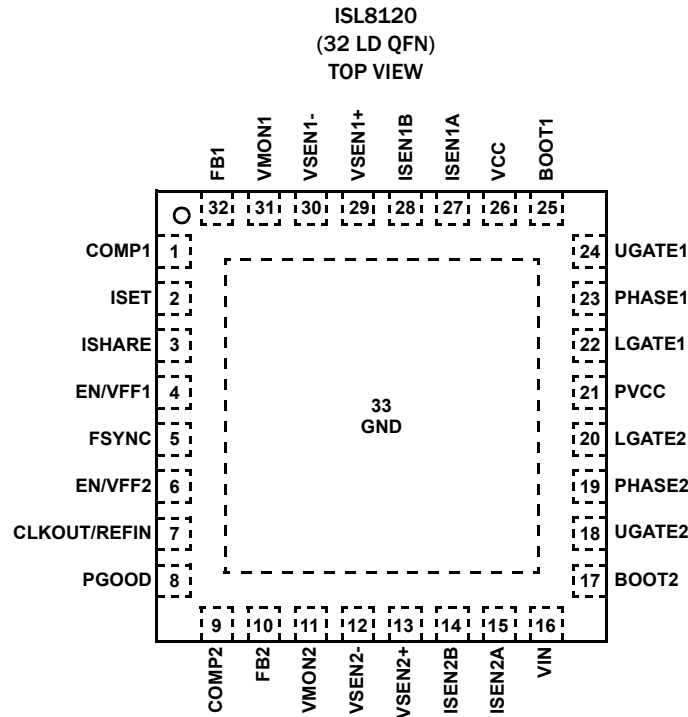

FIGURE 1. INTEGRATED DRIVER BLOCK DIAGRAM

# Table of Contents

<b>Pin Configuration</b> .....	<b>3</b>
<b>Functional Pin Descriptions</b> .....	<b>3</b>
<b>Ordering Information</b> .....	<b>5</b>
<b>Controller Block Diagram</b> .....	<b>6</b>
<b>Typical Application Circuits</b> .....	<b>7</b>
2-Phase Operation with DCR Sensing .....	7
2-Phase Operation with $r_{DS(ON)}$ Sensing .....	8
Dual Regulators with DCR Sensing and Remote Sense .....	9
Double Data Rate I or II .....	10
3-Phase Regulator with Precision Resistor Sensing .....	11
4-Phase Operation with DCR Sensing .....	12
Multiple Power Modules in Parallel with Current Sharing Control .....	13
3-Phase Regulator with Resistor Sensing and 1 Phase Regulator .....	14
6-Phase Operation with DCR Sensing .....	15
<b>Absolute Maximum Ratings</b> .....	<b>16</b>
<b>Thermal Information</b> .....	<b>16</b>
<b>Recommended Operating Conditions</b> .....	<b>16</b>
<b>Electrical Specifications</b> .....	<b>16</b>
<b>Typical Performance Curves</b> .....	<b>19</b>
<b>Modes of Operation</b> .....	<b>21</b>
<b>Functional Description</b> .....	<b>23</b>
Initialization .....	24
Voltage Feed-Forward .....	24
Soft-Start .....	25
Power-Good .....	25
Overvoltage and Undervoltage Protection .....	25
PRE-POR Overvoltage Protection (PRE-POR-OVP) .....	26
Over-Temperature Protection (OTP) .....	26
Inductor Current Sensing .....	26
Resistive Sensing .....	27
Overcurrent Protection .....	28
Current Sharing Loop .....	29
Internal Series Linear and Power Dissipation .....	32
Oscillator .....	33
Frequency Synchronization and Phase Lock Loop .....	33
Differential Amplifier for Remote Sense .....	33
Internal Reference and System Accuracy .....	34
DDR and Dual Mode Operation .....	35
Layout Considerations .....	36
<b>Revision History</b> .....	<b>38</b>
<b>About Intersil</b> .....	<b>38</b>
<b>Package Outline Drawing</b> .....	<b>39</b>

# Pin Configuration



## Functional Pin Descriptions

PIN NUMBER	SYMBOL	DESCRIPTION
1	COMP1	These pins are the error amplifier outputs. They should be connected to FB1, FB2 pins through desired compensation networks when both channels are operating independently. When VSEN1-, VSEN2- are pulled within 400mV of VCC, the corresponding error amplifier is disabled and its output (COMP pin) is high impedance. Thus, in multiphase operations, all other SLAVE phases' COMP pins can tie to the MASTER phase's COMP1 pin (1st phase), which modulates each phase's PWM pulse with a single voltage feedback loop. While the error amplifier is not disabled, an independent compensation network is required for each cascaded IC.
9	COMP2	
2	ISET	This pin sources a 15µA offset current plus the average current of both channels in multiphase mode or only Channel 1's current in independent mode. The voltage (VISET) set by an external resistor (RISET) represents the average current level of the local active channel(s).
3	ISHARE	This pin is used for current sharing purposes and is configured to current share bus representing all modules' average current. It sources 15µA offset current plus the average current of both channels in multiphase mode or Channel 1's current in independent mode. The share bus (ISHARE pins connected together) voltage (VISHARE) set by an external resistor (RISHARE) represents the average current level of all ISL8120 controller connected to current share bus. The ISHARE bus voltage compares with ISET voltage to generates current share error signal for current correction block of each cascaded controller. The share bus impedance RISHARE should be set as RISET/NCTRL (RISET divided by number of ISL8120 in current sharing controllers). There is a 1.2V threshold for average overcurrent protection on this pin. VISHARE is compared with a 1.2V threshold for average overcurrent protections. For full-scale current, RISHARE should be $1.2V/123\mu A \approx 10k\Omega$ . Typically 10kΩ is used for RSHARE and RSET.
4	EN/VFF1	These pins have triple functions. The voltage on EN/FF_ pin is compared with a precision 0.8V threshold for system enable to initiate soft-start. With a voltage lower than the threshold, the corresponding channel can be disabled independently. By connecting these pins to the input rail through a voltage resistor divider, the input voltage can be monitored for UVLO (Undervoltage Lockout) function. The undervoltage lockout and its hysteresis levels can be programmed by these resistor dividers. The voltages on these pins are also fed into the controller to adjust the sawtooth amplitude of each channel independently to realize the feed-forward function. Furthermore, during fault (such as overvoltage, overcurrent, and over-temperature) conditions, these pins are pulled low to communicate the information to other cascaded ICs.
6	EN/VFF2	

## Functional Pin Descriptions (Continued)

PIN NUMBER	SYMBOL	DESCRIPTION
5	FSYNC	The oscillator switching frequency is adjusted by placing a resistor (RFS) from this pin to GND. The internal oscillator will lock to an external frequency source if this pin is connected to a switching square pulse waveform, typically the CLKOUT input signal from another ISL8120 or an external clock. The internal oscillator synchronizes with the leading edge of the input signal.
7	CLKOUT/REFIN	This pin has a dual function depending on the mode in which the chip is operating. It provides a clock signal to synchronize with other ISL8120(s) with its VSEN2- pulled within 400mV of VCC for multiphase (3-, 4-, 6-, 8-, 10-, or 12-phase) operation. When the VSEN2- pin is not within 400mV of VCC, ISL8120 is in dual mode (dual independent PWM output). The clockout signal of this pin is not available in this mode, however, the ISL8120 can be synchronized to external clock. In dual mode, this pin works as the following two functions: <ol style="list-style-type: none"> <li>1. An external reference (0.6V target only) can be in place of the Channel 2's internal reference through this pin for DDR/tracking applications (see <a href="#">"DDR and Dual Mode Operation" on page 35</a>).</li> <li>2. The ISL8120 operates as a dual-PWM controller for two independent regulators with selectable phase degree shift, which is programmed by the voltage level on REFIN (see <a href="#">"DDR and Dual Mode Operation" on page 35</a>).</li> </ol>
8	PGOOD	Provides an open drain power-good signal when both channels are within 9% of the nominal output regulation point with 4% hysteresis (13%/9%) and soft-start complete. PGOOD monitors the outputs (VMON1/2) of the internal differential amplifiers.
32	FB1	These pins are the inverting inputs of the error amplifiers. These pins should be connected to VMON1, VMON2 with the compensation feedback network. No direct connection between FB and VMON pins is allowed. With VSEN2- pulled within 400mV of VCC, the corresponding error amplifier is disabled and the amplifier's output is high impedance. FB2 is one of the two pins to determine the relative phase relationship between the internal clock of both channels and the CLKOUT signal. See <a href="#">Table 1 on page 22</a> .
10	FB2	
31	VMON1	These pins are outputs of the unity gain amplifiers. They are connected internally to the OV/UV/PGOOD comparators. These pins should be connected to the FB1, FB2 pins by a standard feedback network when both channels are operating independently. When VSEN1-, VSEN2- are pulled within 400mV of VCC, the corresponding differential amplifier is disabled and its output (VMON pin) is high impedance. In such an event, the VMON pin can be used as an additional monitor of the output voltage with a resistor divider to protect the system against single point of failure, which occurs in the system using the same resistor divider for both of the UV/OV comparator and output voltage feedback.
11	VMON2	
30	VSEN1-	These pins are the negative inputs of standard unity gain operational amplifier for differential remote sense for the corresponding regulator (Channels 1 and 2), and should be connected to the negative rail of the load/processor. When VSEN1-, VSEN2- are pulled within 400mV of VCC, the corresponding error amplifier and differential amplifier are disabled and their outputs are high impedance. Both VSEN2+ and FB2 input signal levels determine the relative phases between the internal controllers as well as the CLKOUT signal. See <a href="#">Table 1 on page 22</a> . When configured as multiple power modules (each module with independent voltage loop) operating in parallel, in order to implement the current sharing control, a resistor (100Ω typical) needs to be inserted between the VSEN1- pin and the output voltage negative sense point (between VSEN1- and lower voltage sense resistor), as shown in the "Typical Application Circuits" <a href="#">"Multiple Power Modules in Parallel with Current Sharing Control" on page 13</a> . This introduces a correction voltage for the modules with lower load current to keep the current distribution balanced among modules. The module with the highest load current will automatically become the master module. The recommended value for the VSEN1- resistor is 100Ω and it should not be large in order to keep the unit gain amplifier input impedance compatibility.
12	VSEN2-	
29	VSEN1+	These pins are the positive inputs of the standard unity gain operational amplifier for differential remote sense for the corresponding channel (Channels 1 and 2), and should be connected to the positive rail of the load/processor. These pins can also provide precision output voltage trimming capability by pulling a resistor from this pin to the positive rail of the load (trimming down) or the return (typical VSEN1-, VSEN2- pins) of the load (trimming up). The typical input impedance of VSEN+ with respect to VSEN- is 600kΩ. By setting the resistor divider connected from the output voltage to the input of the differential amplifier, the desired output voltage can be programmed. To minimize the system accuracy error introduced by the input impedance of the differential amplifier, a resistor below 1k is recommended to be used for the lower leg (ROS) of the feedback resistor divider. With VSEN2- pulled within 400mV of VCC, the corresponding error amplifier is disabled and VSEN2+ is one of the two pins to determine the relative phase relationship between the internal clock of both channels and the CLKOUT signal. See <a href="#">Table 1 on page 22</a> for details.
13	VSEN2+	
28	ISEN1B	These pins are the inverting (-) inputs of the current sensing amplifiers to provide $r_{DS(ON)}$ , DCR, or precision resistor current sensing together with the ISEN1A, ISEN2A pins. Refer to "Typical Application Circuits" <a href="#">"2-Phase Operation with DCR Sensing" on page 7</a> for DCR sensing set up and <a href="#">"2-Phase Operation with <math>r_{DS(ON)}</math> Sensing" on page 8</a> for $r_{DS(ON)}$ sensing set up.
14	ISEN2B	

## Functional Pin Descriptions (Continued)

PIN NUMBER	SYMBOL	DESCRIPTION
27	ISEN1A	These pins are the noninverting (+) inputs of the current sensing amplifiers to provide $r_{DS(ON)}$ , DCR, or precision resistor current sensing together with the ISEN1B, ISEN2B pins.
15	ISEN2A	
16	VIN	This pin is the input of the internal linear regulator. It should be tied directly to the input rail. The internal linear device is protected against reverse bias generated by the remaining charge of the decoupling capacitor at PVCC when losing the input rail. When used with an external 3.3V to 5V supply, this pin should be tied directly to PVCC.
25	BOOT1	These pins provide the bootstrap biases for the high-side drivers. Internal bootstrap diodes connected to the PVCC pin provide the necessary bootstrap charge. Its typical operational voltage range is 2.5V to 5.6V.
17	BOOT2	
24	UGATE1	These pins provide the gate signals to drive the high-side devices and should be connected to the MOSFETs' gates.
18	UGATE2	
23	PHASE1	Connect these pins to the source of the high-side MOSFETs and the drain of the low-side MOSFETs. These pins represent the return path for the high-side gate drives.
19	PHASE2	
22	LGATE1	These pins provide the drive for the low-side devices and should be connected to the MOSFETs' gates.
20	LGATE2	
21	PVCC	This pin is the output of the internal series linear regulator. It provides the bias for both low-side and high-side drives. Its operational voltage range is 3V to 5.6V. The decoupling ceramic capacitor in the PVCC pin is 10 $\mu$ F.
26	VCC	This pin provides bias power for the analog circuitry. An RC filter is recommended between the connection of this pin to a 3V to 5.6V bias (typically PVCC). R is suggested to be a 5 $\Omega$ resistor. And in 3.3V applications, the R could be shorted to allow the low end input in concerns of the VCC falling threshold. The VCC decoupling capacitor is strongly recommended to be as large as a 10 $\mu$ F ceramic capacitor. This pin can be powered either by the internal linear regulator or by an external voltage source.
33	GND	The bottom pad is the signal and power ground plane. All voltage levels are referenced to this pad. This pad provides a return path for the low-side MOSFET drives and internal power circuitries as well as all analog signals. Connect this pad to the circuit ground with the shortest possible path (more than 5 to 6 vias to the internal ground plane, placed on the soldering pad are recommended).

## Ordering Information

PART NUMBER (Notes 3, 4)	PART MARKING	TEMP. RANGE (°C)	PACKAGE (RoHS COMPLIANT)	PKG. DWG.#
ISL8120CRZ (Note 1)	ISL8120 CRZ	0 to +70	32 Ld QFN	L32.5x5B
ISL8120IRZ (Note 2)	ISL8120 IRZ	-40 to +85	32 Ld QFN	L32.5x5B

1. Add "-T" suffix for 6000 unit Tape and Reel option. Please refer to [TB347](#) for details on reel specifications.
2. Add "-T" suffix for 6000 unit or "-TK" suffix for 1000 unit Tape and Reel options. Please refer to [TB347](#) for details on reel specifications.
3. These Intersil Pb-free plastic packaged products employ special Pb-free material sets, molding compounds/die attach materials, and 100% matte tin plate plus anneal (e3 termination finish, which is RoHS compliant and compatible with both SnPb and Pb-free soldering operations). Intersil Pb-free products are MSL classified at Pb-free peak reflow temperatures that meet or exceed the Pb-free requirements of IPC/JEDEC J STD-020.
4. For Moisture Sensitivity Level (MSL), please see device information page for [ISL8120](#). For more information on MSL please see techbrief [TB363](#).

# Controller Block Diagram

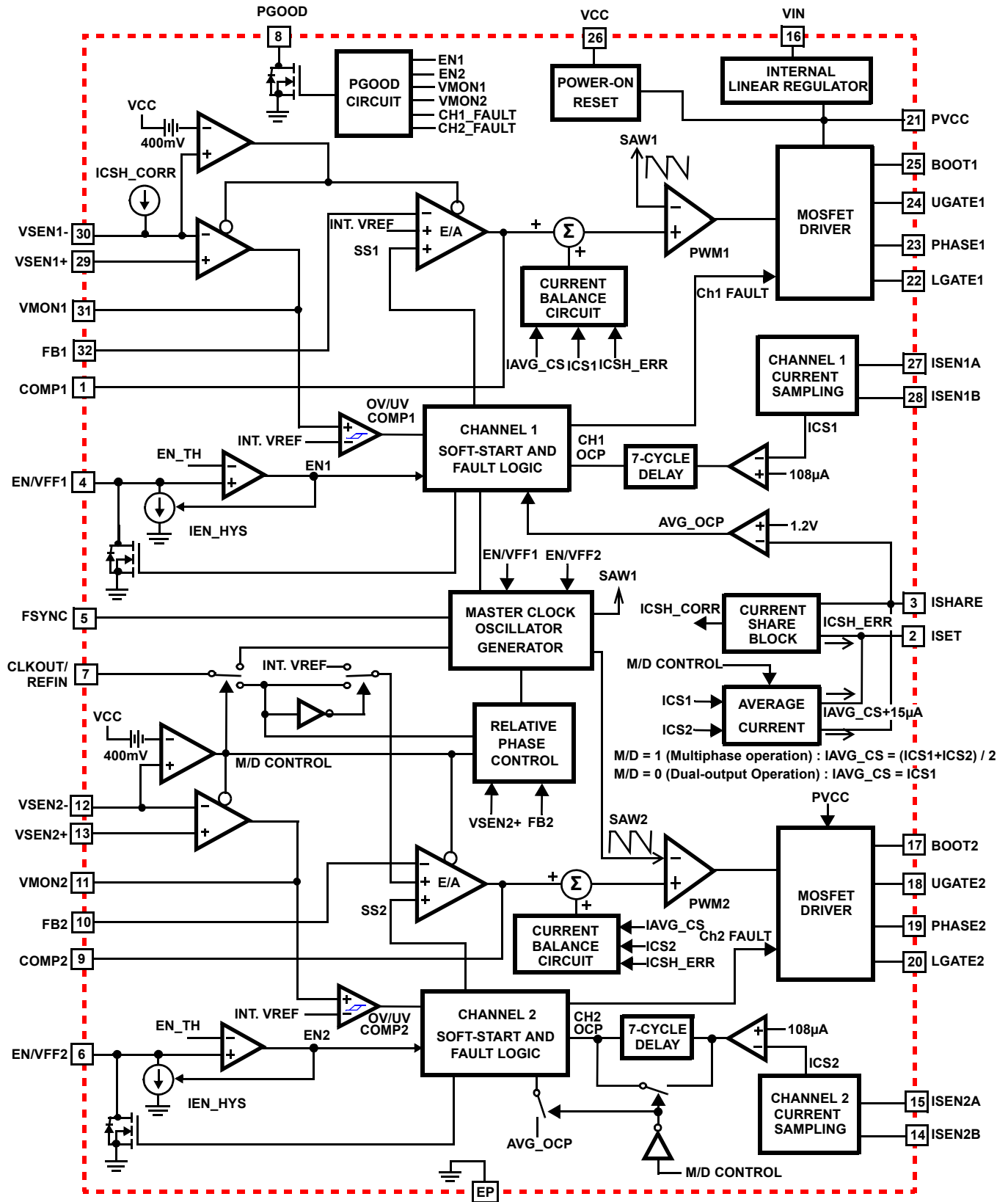

FIGURE 2. CONTROLLER BLOCK DIAGRAM

# Typical Application Circuits

## 2-Phase Operation with DCR Sensing

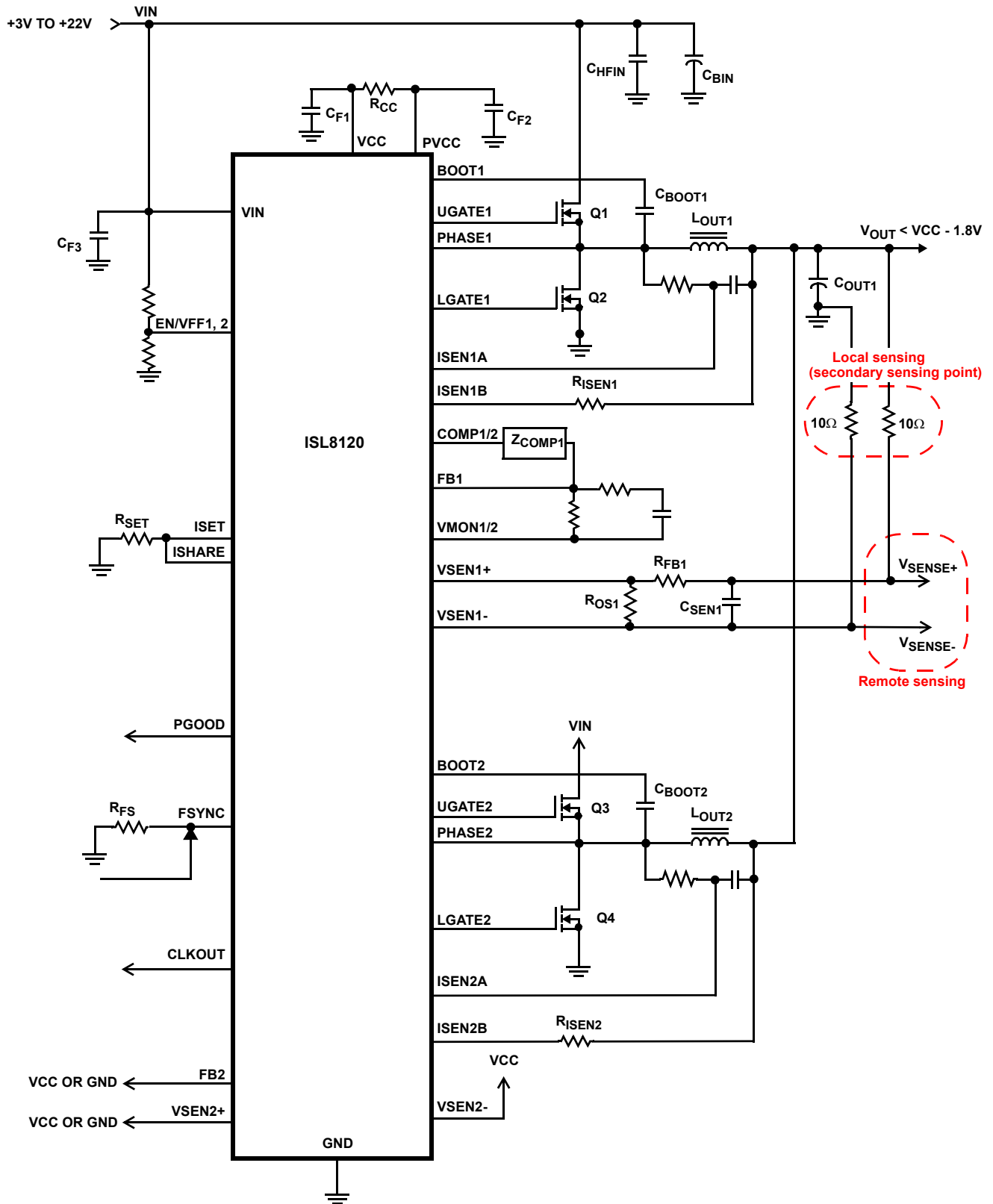

FIGURE 3. 2-PHASE OPERATION WITH DCR SENSING

## Typical Application Circuits (Continued)

### 2-Phase Operation with $r_{DS(ON)}$ Sensing

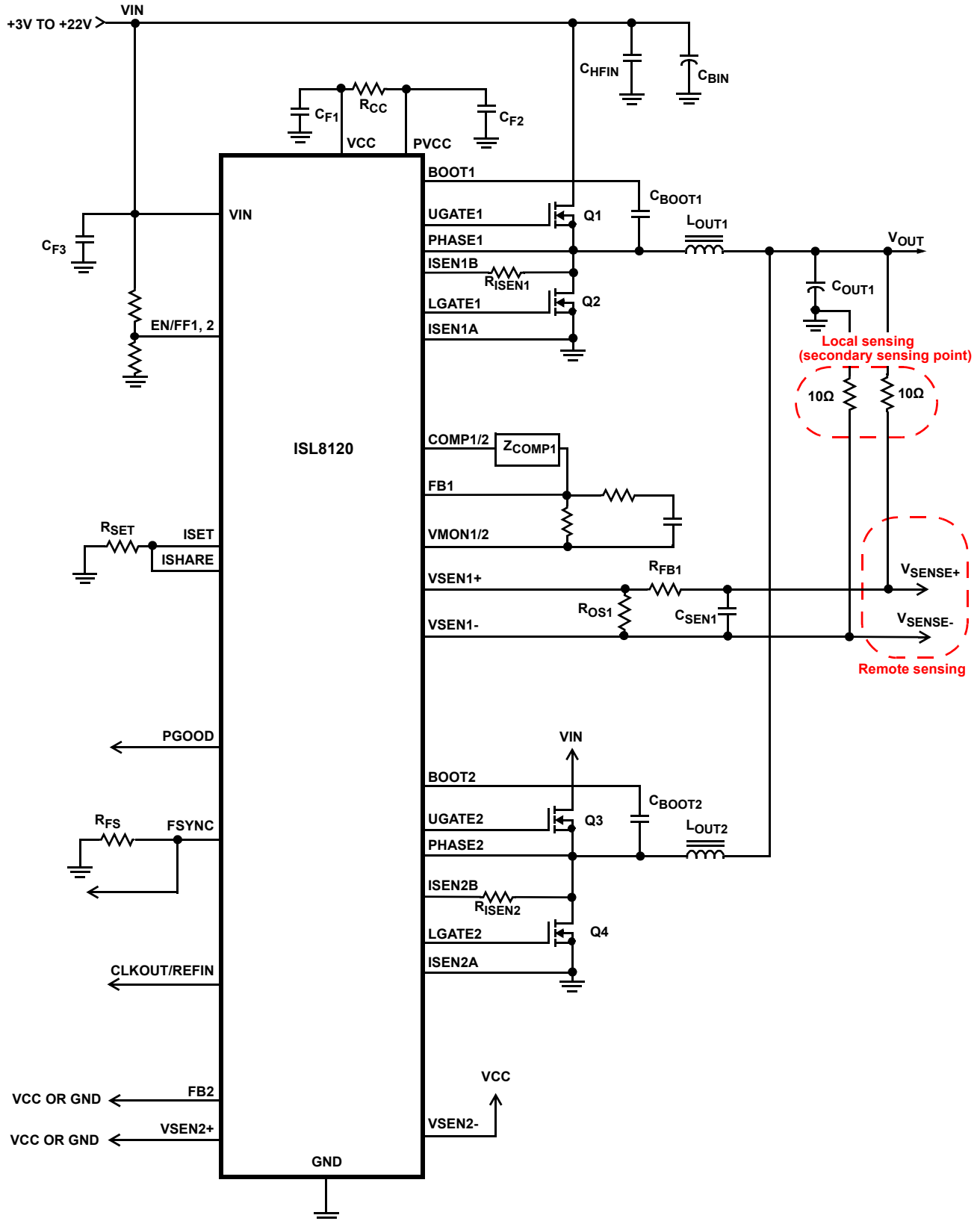

FIGURE 4. 2-PHASE OPERATION WITH  $r_{DS(ON)}$  SENSING

# Typical Application Circuits (Continued)

## Dual Regulators with DCR Sensing and Remote Sense

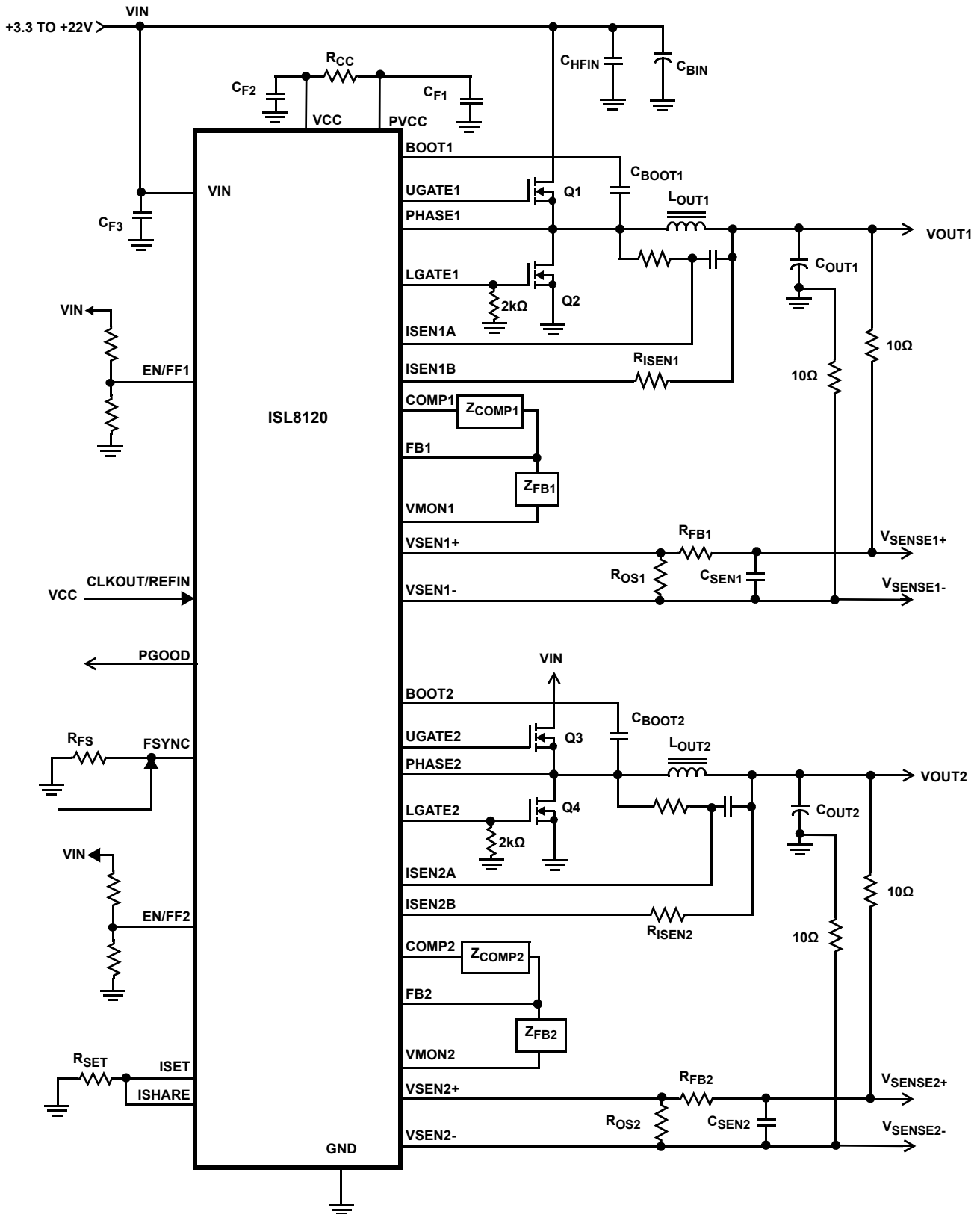
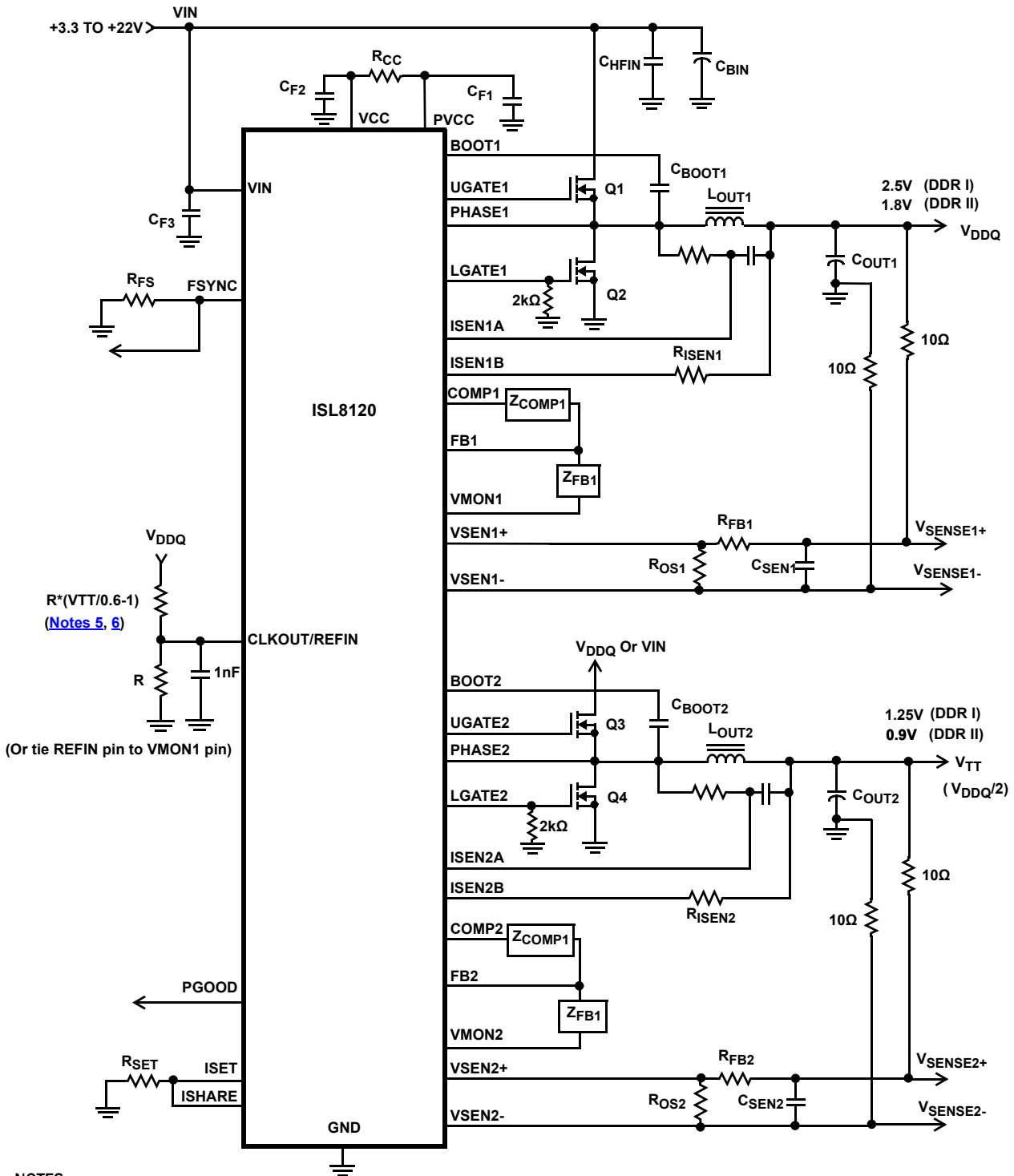

FIGURE 5. DUAL REGULATORS WITH DCR SENSING AND REMOTE SENSE

# Typical Application Circuits (Continued)

## Double Data Rate I or II



**NOTES:**

5. Setting the upper resistor to be a little higher than  $R^*(V_{DDQ}/0.6 - 1)$  will set the final REF pin voltage (steady state voltage after soft-start) derived from the V<sub>DDQ</sub> to be a little higher than internal 0.6V reference. In this way, the V<sub>TT</sub> final voltage will use the internal 0.6V reference after soft-start. The other way is to add more delay at EN/VFF1 pin to have Channel 2 tracking V<sub>DDQ</sub> (check [Table 1 on page 22](#) for more details).
6. Another way to set REF pin voltage is to connect VMON1 directly to the REF pin.

**FIGURE 6. DOUBLE DATA RATE I OR II**

## Typical Application Circuits (Continued)

### 3-Phase Regulator with Precision Resistor Sensing

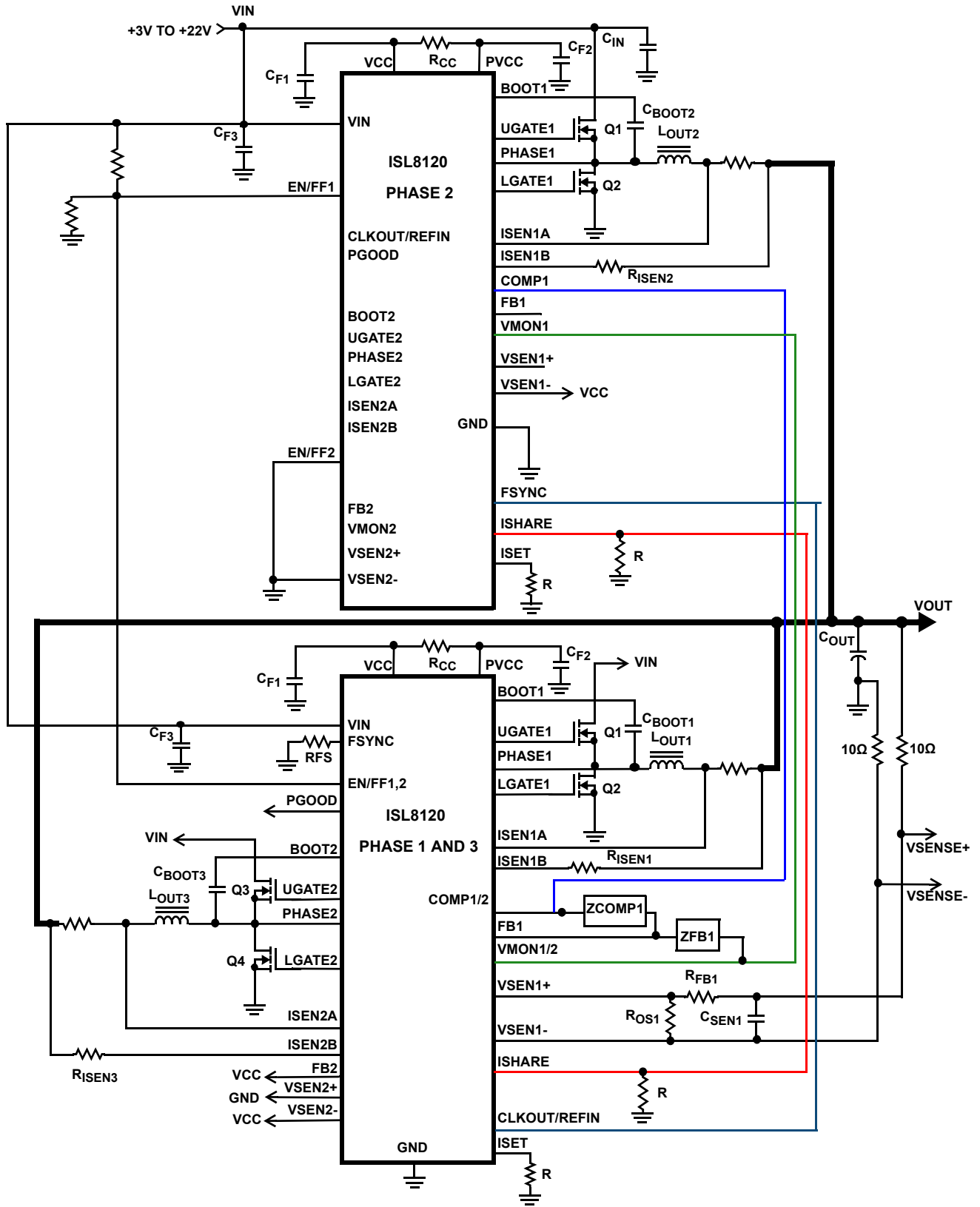

FIGURE 7. 3-PHASE REGULATOR WITH PRECISION RESISTOR SENSING

# Typical Application Circuits (Continued)

## 4-Phase Operation with DCR Sensing

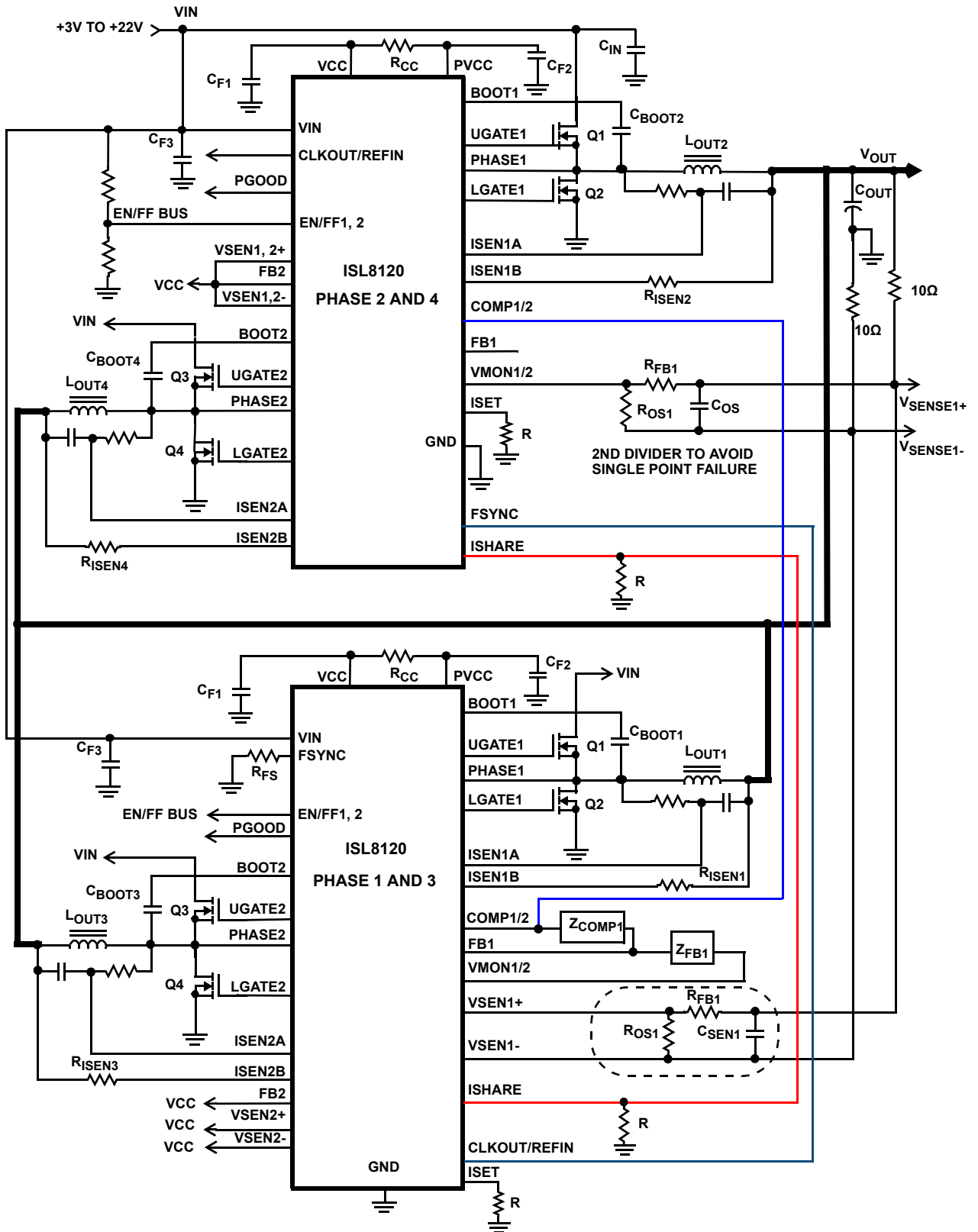

FIGURE 8. 4-PHASE OPERATION WITH DCR SENSING

# Typical Application Circuits (Continued)

## Multiple Power Modules in Parallel with Current Sharing Control

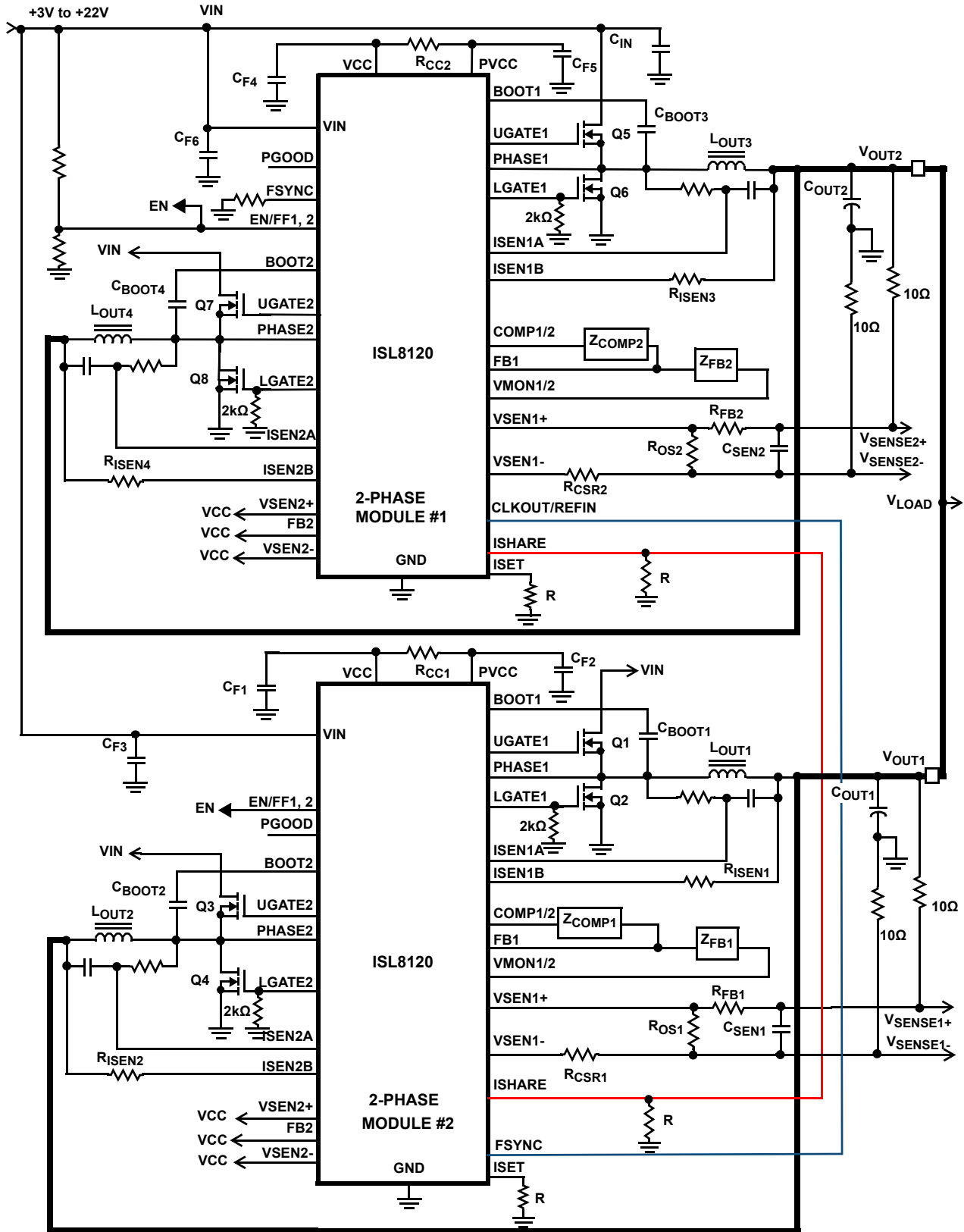

FIGURE 9. MULTIPLE POWER MODULES IN PARALLEL WITH CURRENT SHARING CONTROL

## Typical Application Circuits (Continued)

### 3-Phase Regulator with Resistor Sensing and 1 Phase Regulator

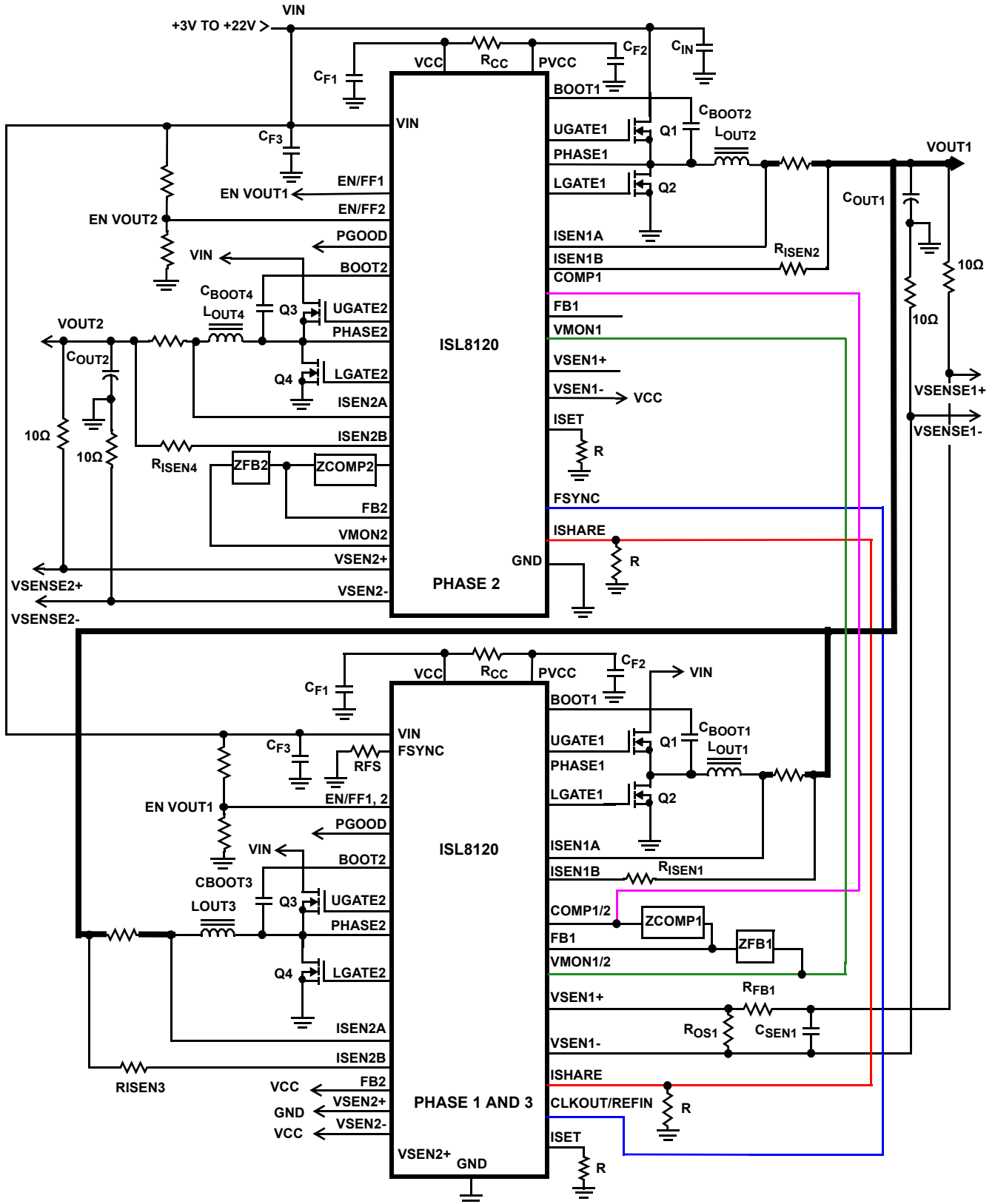

FIGURE 10. 3-PHASE REGULATOR WITH RESISTOR SENSING AND 1 PHASE REGULATOR

# Typical Application Circuits (Continued)

## 6-Phase Operation with DCR Sensing

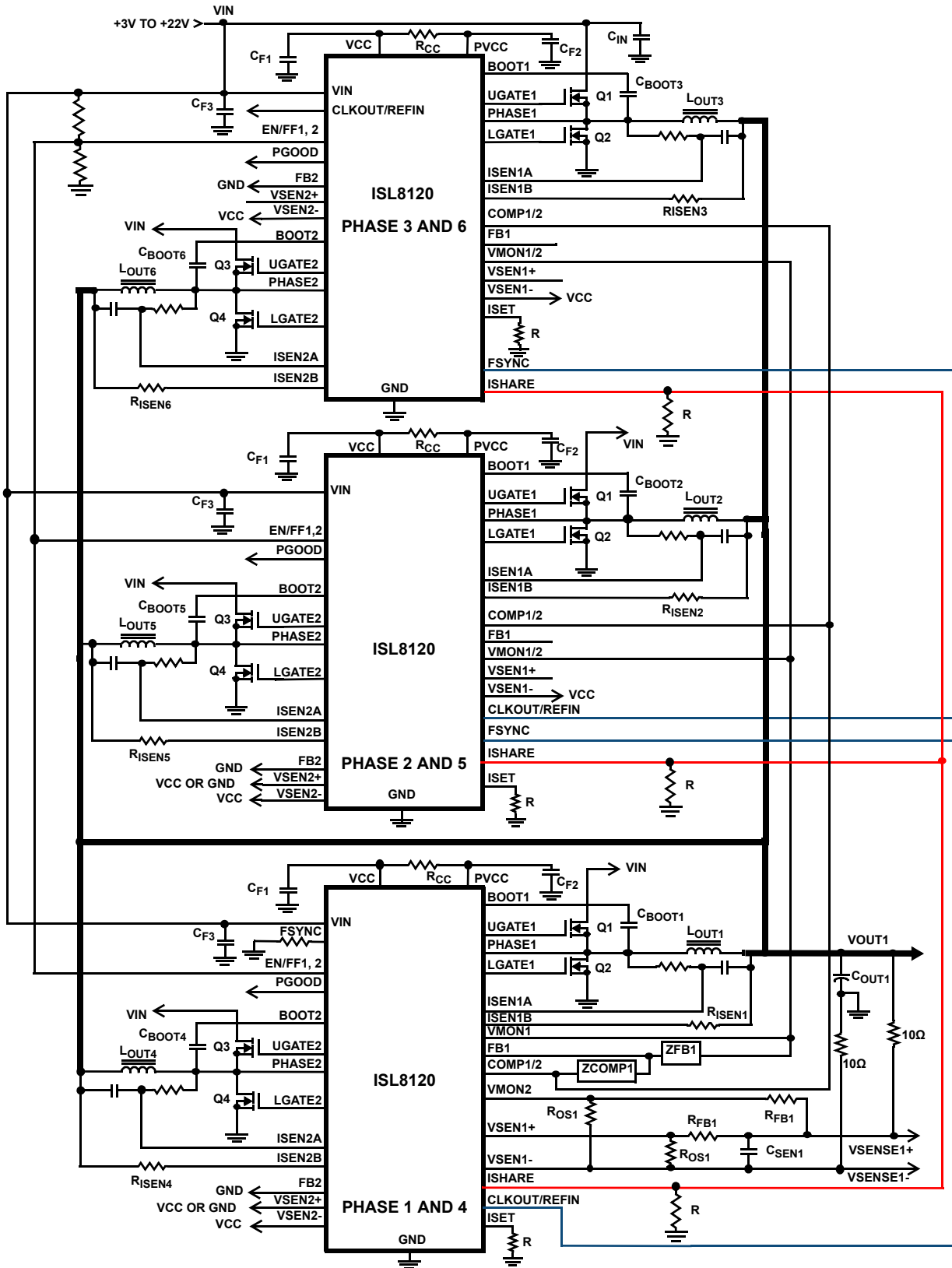

FIGURE 11. 6-PHASE OPERATION WITH DCR SENSING

## Absolute Maximum Ratings

Input Voltage, $V_{IN}$	-0.3V to +27V
Driver Bias Voltage, $PV_{CC}$	-0.3V to +6.5V
Signal Bias Voltage, $V_{CC}$	-0.3V to +6.5V
BOOT/UGATE Voltage, $V_{BOOT}$	-0.3V to +36V
Phase Voltage, $V_{PHASE}$	$(V_{BOOT} - 7V)$ to $V_{BOOT} + 0.3V$
BOOT to PHASE Voltage, $(V_{BOOT} - V_{PHASE})$	-0.3V to $V_{CC} + 0.3V$
Input, Output or I/O Voltage	-0.3V to $V_{CC} + 0.3V$

## Thermal Information

Thermal Resistance (Typical <a href="#">Notes 7, 8</a> )	$\theta_{JA}$ (°C/W)	$\theta_{JC}$ (°C/W)
32 Ld QFN Package	32	3.5
Maximum Junction Temperature	-55°C to +150°C	
Maximum Storage Temperature Range	-65°C to +150°C	
Pb-Free Reflow Profile	see <a href="#">TB493</a>	

## Recommended Operating Conditions

Input Voltage, $V_{IN}$	3V to 22V
Driver Bias Voltage, $PV_{CC}$	3V to 5.6V
Signal Bias Voltage, $V_{CC}$	3V to 5.6V
Boot to Phase Voltage (Overcharged), $(V_{BOOT} - V_{PHASE})$	<6V
Commercial Ambient Temperature Range	0°C to +70°C
Industrial Ambient Temperature Range	-40°C to +85°C
Maximum Junction Temperature Range	+125°C

**CAUTION:** Do not operate at or near the maximum ratings listed for extended periods of time. Exposure to such conditions may adversely impact product reliability and result in failures not covered by warranty.

### NOTES:

- $\theta_{JA}$  is measured in free air with the component mounted on a high effective thermal conductivity test board with “direct attach” features. See Tech Brief [TB379](#).
- For  $\theta_{JC}$ , the “case temp” location is the center of the exposed metal pad on the package underside.

**Electrical Specifications** Recommended operating conditions, unless otherwise noted. **Boldface limits apply across the operating temperature range, -40°C to +85°C (Industrial) or 0°C to +70°C (Commercial).**

PARAMETER	SYMBOL	TEST CONDITIONS	MIN ( <a href="#">Note 10</a> )	TYP	MAX ( <a href="#">Note 10</a> )	UNIT
<b>VCC SUPPLY CURRENT</b>						
Nominal Supply $V_{IN}$ Current	$I_{Q\_VIN}$	$V_{IN} = 20V$ ; $V_{CC} = PV_{CC}$ ; $f_{SW} = 500kHz$ ; UGATE, LGATE = open	<b>11</b>	15	<b>20</b>	mA
Nominal Supply $V_{IN}$ Current	$I_{Q\_VIN}$	$V_{IN} = 3.3V$ ; $V_{CC} = PV_{CC}$ ; $f_{SW} = 500kHz$ ; UGATE, LGATE = open	<b>8</b>	12	<b>14</b>	mA
Shutdown Supply $PV_{CC}$ Current	$I_{PV_{CC}}$	EN = 0V, $PV_{CC} = 5V$	<b>0.5</b>	1.0	<b>1.4</b>	mA
Shutdown Supply VCC Current	$I_{V_{CC}}$	EN = 0V, $V_{CC} = 3V$	<b>7</b>	10	<b>12</b>	mA
<b>INTERNAL LINEAR REGULATOR</b>						
Maximum Current ( <a href="#">Note 9</a> )	$I_{PV_{CC}}$	$PV_{CC} = 4V$ to 5.6V		250		mA
		$PV_{CC} = 3V$ to 4V		150		mA
Saturated Equivalent Impedance ( <a href="#">Note 9</a> )	$R_{LDO}$	P-Channel MOSFET ( $V_{IN} = 5V$ )		1		$\Omega$
PVCC Voltage Level	PVCC	$I_{PV_{CC}} = 0mA$ ; 0°C < $T_A$ < +85°C; $V_{IN} = 12V$	<b>5.15</b>	5.40	<b>5.65</b>	V
		$I_{PV_{CC}} = 0mA$ ; -40°C < $T_A$ < +85°C; $V_{IN} = 12V$	<b>5.15</b>	5.40	<b>5.95</b>	V
Equivalent LDO Output Resistance	$R_{LDO\_OUT}$	$V_{IN} = 12V$		0.3		$\Omega$
<b>POWER-ON RESET</b>						
Rising $V_{CC}$ Threshold				2.85	<b>2.97</b>	V
Falling $V_{CC}$ Threshold				2.65	<b>2.75</b>	V
Rising $PV_{CC}$ Threshold		0°C < $T_A$ < +75°C		2.85	<b>2.97</b>	V
		-40°C < $T_A$ < +85°C		2.85	<b>3.05</b>	V
Falling $PV_{CC}$ Threshold				2.65	<b>2.75</b>	V

**Electrical Specifications** Recommended operating conditions, unless otherwise noted. **Boldface limits apply across the operating temperature range, -40°C to +85°C (Industrial) or 0°C to +70°C (Commercial). (Continued)**

PARAMETER	SYMBOL	TEST CONDITIONS	MIN (Note 10)	TYP	MAX (Note 10)	UNIT
System Soft-Start Delay (Note 9)	t <sub>SS_DLY</sub>	After PLL, V <sub>CC</sub> , and PV <sub>CC</sub> PORs, and EN(s) above their thresholds		384		Cycles
<b>ENABLE</b>						
Turn-On Threshold Voltage			<b>0.75</b>	0.8	<b>0.86</b>	V
Hysteresis Sink Current	I <sub>EN_HYS</sub>	0°C < T <sub>A</sub> < +85°C	<b>25</b>	30	<b>35</b>	μA
		-40°C < T <sub>A</sub> < +85°C	<b>23</b>	30	<b>35</b>	μA
Undervoltage Lockout Hysteresis (Note 9)	V <sub>EN_HYS</sub>	V <sub>EN_RTH</sub> = 10.6V; V <sub>EN_FTH</sub> = 9V R <sub>UP</sub> = 53.6kΩ, R <sub>DOWN</sub> = 5.23kΩ		1.6		V
Sink Current	I <sub>EN_SINK</sub>	V <sub>ENFF</sub> = 1V	<b>15.4</b>			mA
Sink Impedance	R <sub>EN_SINK</sub>	V <sub>ENFF</sub> = 1V			<b>64</b>	Ω
<b>OSCILLATOR</b>						
Oscillator Frequency Range			<b>150</b>		<b>1500</b>	kHz
Oscillator Frequency		R <sub>FS</sub> = 100k, <a href="#">Figure 42 on page 33</a>	<b>344</b>	377	<b>406</b>	kHz
Total Variation		V <sub>CC</sub> = 5V; -40°C < T <sub>A</sub> < +85°C	<b>-9</b>		<b>+9</b>	%
Peak-to-Peak Ramp Amplitude	ΔV <sub>RAMP</sub>	V <sub>CC</sub> = 5V, V <sub>EN</sub> = 0.8V		1		V <sub>P-P</sub>
Linear Gain of Ramp Over V <sub>EN</sub>	G <sub>RAMP</sub>	G <sub>RAMP</sub> = ΔV <sub>RAMP</sub> /V <sub>EN</sub>		1.25		
Ramp Peak Voltage	V <sub>RAMP_PEAK</sub>	V <sub>EN</sub> = V <sub>CC</sub>		V <sub>CC</sub> - 1.4		V
Peak-to-Peak Ramp Amplitude	ΔV <sub>RAMP</sub>	V <sub>EN</sub> = V <sub>CC</sub> = 5.4V, R <sub>UP</sub> = 2k		3		V <sub>P-P</sub>
Peak-to-Peak Ramp Amplitude	ΔV <sub>RAMP</sub>	V <sub>EN</sub> = V <sub>CC</sub> = 3V; R <sub>UP</sub> = 2k		0.6		V <sub>P-P</sub>
Ramp Amplitude Upon Disable	ΔV <sub>RAMP</sub>	V <sub>EN</sub> = 0V; V <sub>CC</sub> = 3.5V to 5.5V		1		V <sub>P-P</sub>
Ramp Amplitude Upon Disable	ΔV <sub>RAMP</sub>	V <sub>EN</sub> = 0V; V <sub>CC</sub> < 3.4V		V <sub>CC</sub> - 2.4		V <sub>P-P</sub>
Ramp DC Offset	V <sub>RAMP_OS</sub>			1		V
<b>FREQUENCY SYNCHRONIZATION AND PHASE LOCK LOOP</b>						
Synchronization Frequency		V <sub>CC</sub> = 5V	<b>150</b>		<b>1500</b>	kHz
PLL Locking Time		V <sub>CC</sub> = 5.4V; f <sub>SW</sub> = 400kHz		105		μs
		V <sub>CC</sub> = 2.97V; f <sub>SW</sub> = 400kHz		150		μs
Input Signal Duty Cycle Range (Note 9)			<b>10</b>		<b>90</b>	%
<b>PWM</b>						
Minimum PWM OFF Time	t <sub>MIN_OFF</sub>		<b>310</b>	345	<b>410</b>	ns
Current Sampling Blanking Time (Note 9)	t <sub>BLANKING</sub>			175		ns
<b>REFERENCE</b>						
Channel 1 Reference Voltage (Include Error and Differential Amplifiers' Offsets)	V <sub>REF1</sub>	-0°C < T <sub>A</sub> < +70°C		0.6		V
			<b>-0.6</b>		<b>0.6</b>	%
		-40°C < T <sub>A</sub> < +85°C		0.6		V
			<b>-0.7</b>		<b>0.7</b>	%
Channel 2 Reference Voltage (Include Error and Differential Amplifiers' Offsets)	V <sub>REF2</sub>	-0°C < T <sub>A</sub> < +70°C		0.6		V
			<b>-0.75</b>		<b>0.75</b>	%
		-40°C < T <sub>A</sub> < +85°C		0.6		V
			<b>-0.75</b>		<b>0.95</b>	%

**Electrical Specifications** Recommended operating conditions, unless otherwise noted. **Boldface limits apply across the operating temperature range, -40°C to +85°C (Industrial) or 0°C to +70°C (Commercial).** (Continued)

PARAMETER	SYMBOL	TEST CONDITIONS	MIN (Note 10)	TYP	MAX (Note 10)	UNIT
<b>ERROR AMPLIFIER</b>						
DC Gain (Note 9)		$R_L = 10k, C_L = 100pF$ , at COMP Pin		98		dB
Unity Gain-Bandwidth (Note 9)	UGBW_EA	$R_L = 10k, C_L = 100pF$ , at COMP Pin		80		MHz
Input Common-Mode Range (Note 9)			<b>-0.2</b>		<b><math>V_{CC} - 1.8</math></b>	V
Output Voltage Swing		$V_{CC} = 5V$	<b>0.85</b>		<b><math>V_{CC} - 1.0</math></b>	V
Slew Rate (Note 9)	SR_EA	$R_L = 10k, C_L = 100pF$ , at COMP Pin		20		V/ $\mu$ s
Input Current (Note 9)	$I_{FB}$	Positive direction Into the FB pin		100		nA
Output Sink Current	$I_{COMP}$			3		mA
Output Source Current	$I_{COMP}$			6		mA
Disable Threshold (Note 9)	$V_{VSEN-}$			$V_{CC} - 0.4$		V
<b>DIFFERENTIAL AMPLIFIER</b>						
DC Gain (Note 9)	UG_DA	Unity Gain Amplifier		0		dB
Unity Gain Bandwidth (Note 9)	UGBW_DA			5		MHz
VSEN+ pin Sourcing Current	$I_{VSEN+}$		<b>0.2</b>	1	<b>2.5</b>	$\mu$ A
Maximum Source Current for Current Sharing (See Figure 7 on page 11) (Note 9)	$I_{VSEN1-}$	VSEN1- Source current for current Sharing when parallel multiple modules each of which has its own voltage loop		350		$\mu$ A
Input Impedance	$R_{VSEN+ \text{ to } VSEN-}$	$V_{VSEN+} / I_{VSEN+}, V_{VSEN+} = 0.6V$		-600		k $\Omega$
Output Voltage Swing (Note 9)			<b>0</b>		<b><math>V_{CC} - 1.8</math></b>	V
Input Common-Mode Range (Note 9)			<b>-0.2</b>		<b><math>V_{CC} - 1.8</math></b>	V
Disable Threshold (Note 9)	$V_{VSEN-}$	$V_{MON1}, V_{MON2} = \text{Tri-state}$		$V_{CC} - 0.4$		V
<b>GATE DRIVERS</b>						
Upper Drive Source Resistance	$R_{UGATE}$	45mA source current		1.0		$\Omega$
Upper Drive Sink Resistance	$R_{UGATE}$	45mA sink current		1.0		$\Omega$
Lower Drive Source Resistance	$R_{LGATE}$	45mA source current		1.0		$\Omega$
Lower Drive Sink Resistance	$R_{LGATE}$	45mA sink current		0.4		$\Omega$
<b>OVERCURRENT PROTECTION</b>						
Channel Overcurrent Limit (Note 9)	$I_{SOURCE}$	$V_{CC} = 2.97V$ to 5.6V		108		$\mu$ A
Channel Overcurrent Limit	$I_{SOURCE}$	$V_{CC} = 5V; 0^\circ C < T_A < +70^\circ C$	<b>94</b>	108	<b>122</b>	$\mu$ A
		$V_{CC} = 5V; -40^\circ C < T_A < +85^\circ C$	<b>89</b>	108	<b>122</b>	$\mu$ A
Share Pin OC Threshold	$V_{OC\_SHARE}$	$V_{CC} = 2.97V$ to 5.6V (comparator offset included)		1.20		V
		$V_{CC} = 5V$ (comparator offset included)	<b>1.16</b>	1.20	<b>1.22</b>	V
<b>CURRENT SHARE</b>						
Internal Balance Accuracy (Note 9)		$V_{CC} = 2.97V$ and 5.6V, 1% resistor sense, 10mV signal		$\pm 5$		%
Internal Balance Accuracy (Note 9)		$V_{CC} = 4.5V$ and 5.6V, 1% resistor sense, 10mV signal		$\pm 5$		%

**Electrical Specifications** Recommended operating conditions, unless otherwise noted. **Boldface limits apply across the operating temperature range, -40°C to +85°C (Industrial) or 0°C to +70°C (Commercial).** (Continued)

PARAMETER	SYMBOL	TEST CONDITIONS	MIN (Note 10)	TYP	MAX (Note 10)	UNIT
External Current Share Accuracy (Note 9)		$V_{CC} = 2.97V$ and $5.6V$ , 1% resistor sense, 10mV signal		$\pm 20$		%
<b>POWER-GOOD MONITOR</b>						
Undervoltage Falling Trip Point	$V_{UVF}$	Percentage below reference point	<b>-15</b>	<b>-13</b>	<b>-11</b>	%
Undervoltage Rising Hysteresis	$V_{UVR\_HYS}$	Percentage above UV trip point		<b>4</b>		%
Overvoltage Rising Trip Point	$V_{OVR}$	Percentage above reference point	<b>11</b>	<b>13</b>	<b>15</b>	%
Overvoltage Falling Hysteresis	$V_{OVF\_HYS}$	Percentage below OV trip point		<b>4</b>		%
PGOOD Low Output Voltage		$I_{PGOOD} = 2mA$			<b>0.35</b>	V
Sinking Impedance		$I_{PGOOD} = 2mA$			<b>70</b>	$\Omega$
Maximum Sinking Current (Note 9)		$V_{PGOOD} < 0.8V$		<b>10</b>		mA
<b>OVERVOLTAGE PROTECTION</b>						
OV Latching Trip Point		EN/FF = UGATE = LATCH low, LGATE = High	<b>118</b>	<b>120</b>	<b>122</b>	%
OV Non-Latching Trip Point (Note 9)		EN/FF = Low, UGATE = Low, LGATE = High		<b>113</b>		%
LGATE Release Trip Point		EN/FF = Low/HIGH, UGATE = Low, LGATE = Low		<b>87</b>		%
<b>OVER-TEMPERATURE PROTECTION</b>						
Over-Temperature Trip (Note 9)				<b>150</b>		$^{\circ}C$
Over-Temperature Release Threshold (Note 9)				<b>125</b>		$^{\circ}C$

## NOTES:

- Limits should be considered typical and are not production tested.
- Compliance to datasheet limits is assured by one or more methods: production test, characterization and/or design.

## Typical Performance Curves

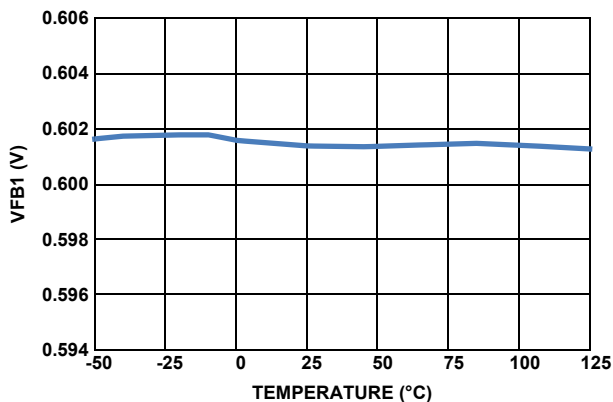

FIGURE 12. CHANNEL 1 ACCURACY vs TEMPERATURE

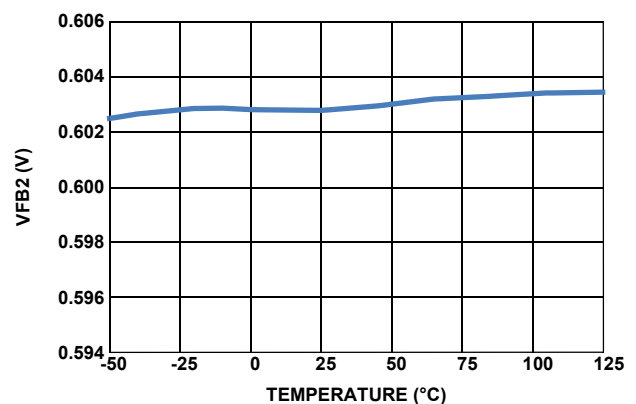

FIGURE 13. CHANNEL 2 ACCURACY vs TEMPERATURE

## Typical Performance Curves (Continued)

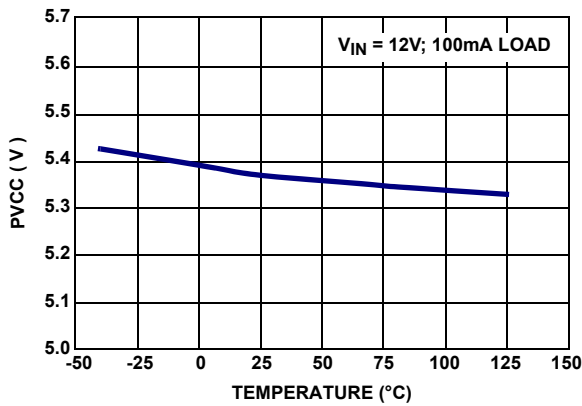

FIGURE 14. PVCC vs TEMPERATURE

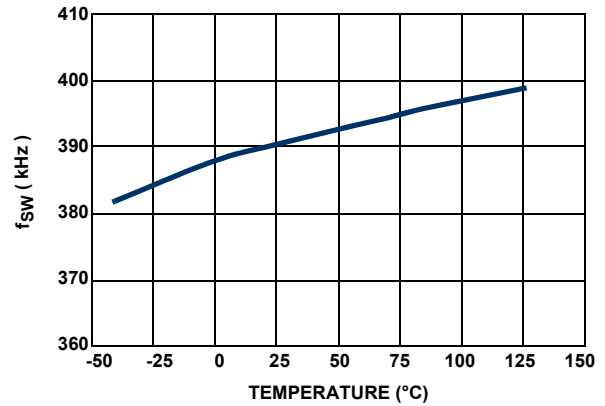

FIGURE 15. SWITCHING FREQUENCY vs TEMPERATURE

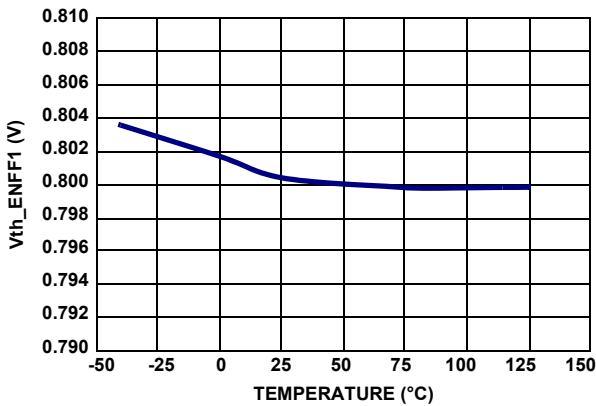

FIGURE 16. VENFF1 ENABLE THRESHOLD vs TEMPERATURE

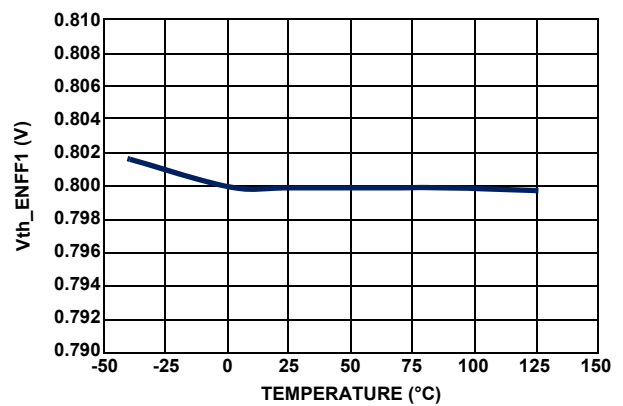

FIGURE 17. VENFF2 ENABLE THRESHOLD vs TEMPERATURE

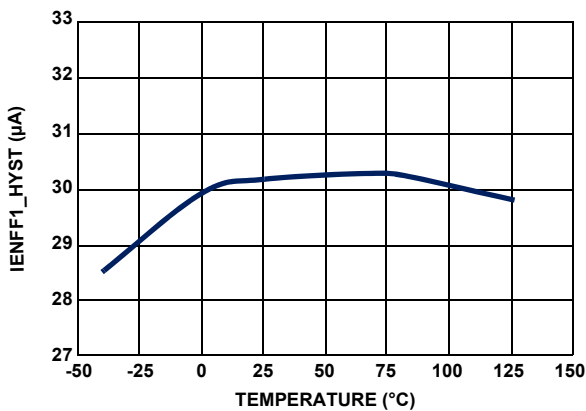

FIGURE 18. ENFF1 HYSTERESIS CURRENT vs TEMPERATURE

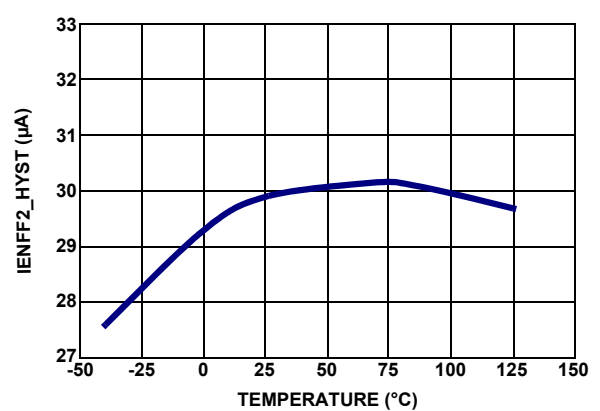

FIGURE 19. ENFF2 HYSTERESIS CURRENT vs TEMPERATURE

## Modes of Operation

There are 9 typical operation modes depending upon the signal levels on EN1/FF1, EN2/FF2, VSEN2+, VSEN2-, FB2 and CLKOUT/REFIN.

**MODE 1:** The IC is completely disabled when EN1/FF1 and EN2/FF2 are pulled below 0.8V.

**MODE 2:** With EN1/FF1 pulled low and EN2/FF2 pulled high (Mode 2A), or EN1/FF1 pulled high and EN2/FF2 pulled low (Mode 2B), the ISL8120 operates as a single phase regulator. The current sourcing out from the ISHARE pin represents the first channel current plus 15 $\mu$ A offset current.

**MODE 3:** When VSEN2- is used as a negative sense line, both channels' phase shift depends upon the voltage level of CLKOUT/REFIN. When the CLKOUT/REFIN pin is within 29% to 45% of VCC, Channel 2 delays 0° over Channel 1 (Mode 3A); when within 45% to 62% of VCC, 90° delay (Mode 3B); when greater than 62% to VCC, 180° delay (Mode 3C). Refer to the [“Internal Reference and System Accuracy” on page 34](#).

**MODE 4:** When VSEN2- is used as a negative remote sense line, and CLKOUT/REFIN is connected to an external voltage ramp lower than the internal soft-start ramp and lower than 0.6V, the external ramp signal will replace Channel 2's internal soft-start ramp to be tracked at start-up, controller operating in DDR mode. The controller will use the lowest voltage among the internal 0.6V reference, the external voltage in CLKOUT/REFIN pin and the soft-start ramp signal. Channel 1 is delayed 60° behind Channel 2. Refer to the [“Internal Reference and System Accuracy” on page 34](#).

**MODE 5:** With VSEN2- pulled within 400mV of VCC and FB2 pulled to ground, the internal channels are 180° out-of-phase and operate in 2-phase single output mode (5A). The CLKOUT/REFIN pin (rising edge) also signals out clock with 60° phase shift relative to the Channel 1's clock signal (falling edge of PWM) for 6-phase operation with two other ISL8120s (5B). When the share pins are not connected to each other for the three ICs in sync, two of which can operate in Mode 5A (3 independent outputs can be generated (Mode 5D) and Modes 3 and 4 (to generate 4 independent outputs (Mode 5C), respectively.

**MODE 6:** With VSEN2- pulled within 400mV of VCC, FB2 pulled high and VSEN2+ pulled low, the internal channels (as 1st and 3rd Phase, respectively) are 240° out-of-phase and operate in 3-phase single output mode, combined with another ISL8120 at MODE 2B. The CLKOUT/REFIN pin signals out 120° relative phases to the falling edge of Channel 1's clock signal to synchronize with the second ISL8120's Channel 1 (as 2nd Phase).

**MODE 7:** With VSEN2- pulled within 400mV of VCC and FB2 and VSEN2+ pulled high, the internal channel is 180° out-of-phase. The CLKOUT/REFIN pin (rising edge) signals out 90° relative phase to the Channel 1's clock signal (falling edge of PWM) to synchronize with another ISL8120, which can operate at Mode 3, 4, 5A, or 7A. A 4-phase single output converter can be constructed with two ISL8120s operating in Mode 5A or 7A (Mode 7A). If the share bus is not connected between ICs, each IC could generate an independent output (Mode 7B). When the second ISL8120 operates as two independent regulators (Mode 3) or in DDR mode (Mode 4), then a three independent output system is generated (Mode 7C). Both ICs can also be constructed as a 3-phase converter (0°, 90°, and 180°, not an equal phase shift for 3-phase) with a single phase regulator (270°).

**MODE 8:** The output CLKOUT signal allows expansion for 12-phase operation with the cascaded sequencing, as shown in [Table 1 on page 22](#). No external clock is required in this mode for the desired phase shift.

**MODE 9:** With an external clock, the part can be expanded for 5-, 7-, 8-, 9- 10- and 11-phase single output operation with the desired phase shift.

TABLE 1.

MODE	1ST IC (I = INPUT; O = OUTPUT; I/O = INPUT AND OUTPUT, BIDIRECTION)										MODES OF OPERATION	
	EN1/ VFF1 (I)	EN2/ VFF2 (I)	VSEN2- (I)	FB2 (I)	VSEN2+ (I)	CLKOUT/REFIN WRT 1ST (I or O)	ISHARE (I/O) REPRESENTS WHICH CHANNEL(S) CURRENT	2ND CHANNEL WRT 1ST (O) (Note 11)	OPERATION MODE of 2ND IC	OPERATION MODE of 3RD IC		
1	<0.8V	<0.8V	-	-	-	-	-	-	-	-		
2A	<0.8V	>0.8V	ACTIVE	ACTIVE	ACTIVE	-	N/A	-	-	-		
2B	>0.8V	<0.8V	-	-	-	-	1 <sup>ST</sup> Channel	-	-	-		
3A	>0.8V	>0.8V	<V <sub>CC</sub> -0.4V	ACTIVE	ACTIVE	29% to 45% of V <sub>CC</sub> (I)	1 <sup>ST</sup> Channel	0°	-	-		
3B	>0.8V	>0.8V	<V <sub>CC</sub> -0.4V	ACTIVE	ACTIVE	45% to 62% of V <sub>CC</sub> (I)	1 <sup>ST</sup> Channel	90°	-	-		
3C	>0.8V	>0.8V	<V <sub>CC</sub> -0.4V	ACTIVE	ACTIVE	> 62% of V <sub>CC</sub> (I)	1 <sup>ST</sup> Channel	180°	-	-		
4	>0.8V	>0.8V	<V <sub>CC</sub> -0.4V	ACTIVE	ACTIVE	< 29% of V <sub>CC</sub> (I)	1 <sup>ST</sup> Channel	-60°	-	-		
5A	Note 12	Note 12	V <sub>CC</sub>	GND	V <sub>CC</sub> /GND	60°	Average of Channel 1 and 2	180°	-	-		
5B	Note 12	Note 12	V <sub>CC</sub>	GND	V <sub>CC</sub> /GND	60°	Average of Channel 1 and 2	180°	5A	5A or 7A		
5C	Note 12	Note 12	V <sub>CC</sub>	GND	V <sub>CC</sub> /GND	60°	Average of Channel 1 and 2	180°	5A	5A or 7A		
5D	Note 12	Note 12	V <sub>CC</sub>	GND	V <sub>CC</sub> /GND	60°	Average of Channel 1 and 2	180°	5A	3 or 4		
6	Note 12	Note 12	V <sub>CC</sub>	V <sub>CC</sub>	GND	120°	Average of Channel 1 and 2	240°	2B	-		
7A	Note 12	Note 12	V <sub>CC</sub>	V <sub>CC</sub>	V <sub>CC</sub>	90°	Average of Channel 1 and 2	180°	5A or 7A	-		
7B	Note 12	Note 12	V <sub>CC</sub>	V <sub>CC</sub>	V <sub>CC</sub>	90°	Average of Channel 1 and 2	180°	5A or 7A	-		
7C	Note 12	Note 12	V <sub>CC</sub>	V <sub>CC</sub>	V <sub>CC</sub>	90°	Average of Channel 1 and 2	180°	3, 4	-		
8	Cascaded IC Operation MODEs 5A + 5A + 7A + 5A + 5A + 5A + 5A/7A, No External Clock Required											
9	External Clock or External Logic Circuits Required for Equal Phase Interval											

NOTES:

11. "2ND CHANNEL WRT 1ST" is referred to as "Channel 2 lag Channel 1 by the degrees specified by the number in the corresponding table cells". For example, 90° means Channel 2 lags Channel 1 by 90°; -60° with 2ND CHANNEL WRT 1ST means Channel 2 leads Channel 1 by 60°.
12. All EN/FF pins are tied together.

# Functional Description

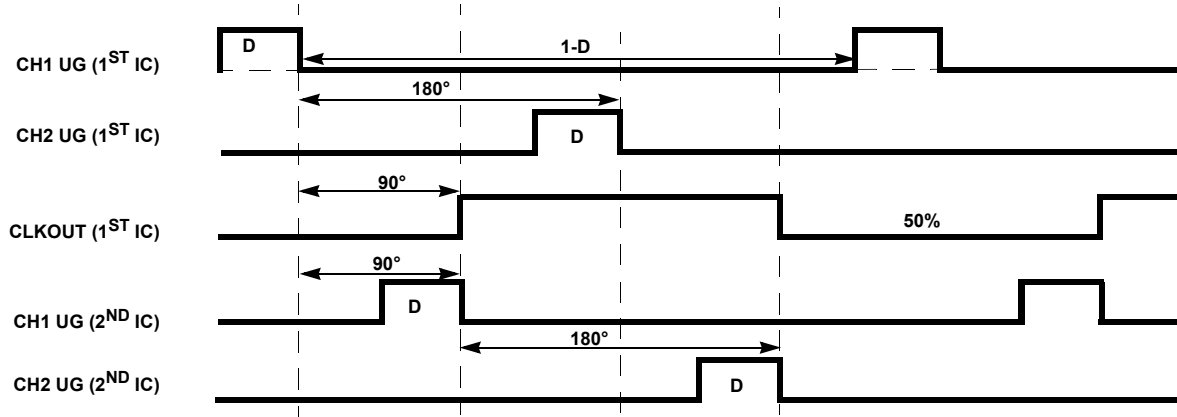

FIGURE 20. 4-PHASE TIMING DIAGRAM (MODE 7A)

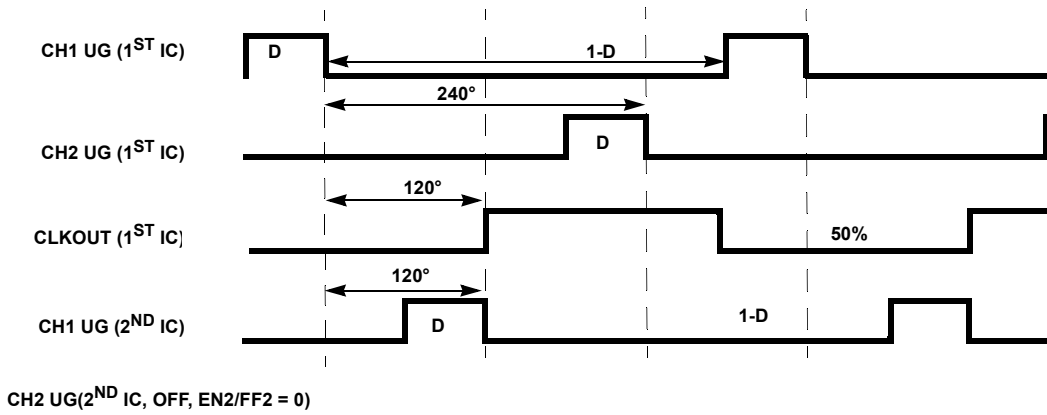

FIGURE 21. 3-PHASE TIMING DIAGRAM (MODE 6)

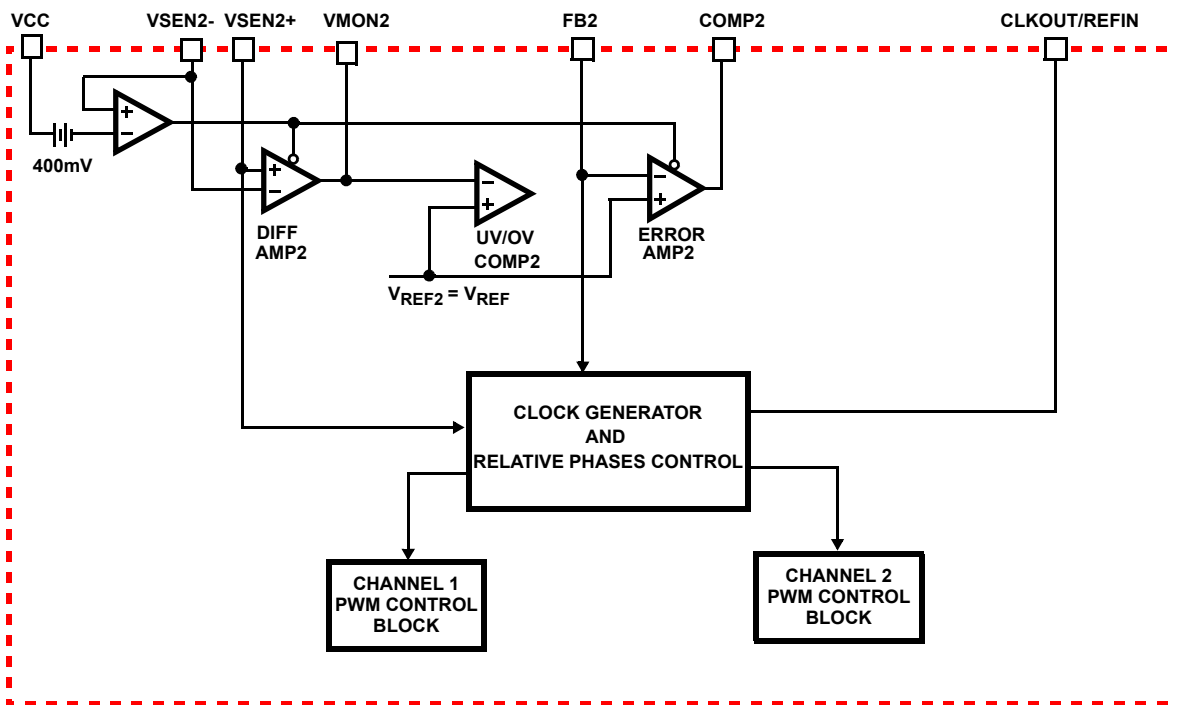

FIGURE 22. SIMPLIFIED RELATIVE PHASES CONTROL

### Initialization

Initially, the ISL8120 Power-On Reset (POR) circuits continually monitor the bias voltages (PVCC and VCC) and the voltage at the EN pin. The POR function initiates soft-start operation 384 clock cycles after the EN pin voltage is pulled to be above 0.8V, all input supplies exceed their POR thresholds and the PLL locking time expires, as shown in Figure 23. During shutdown or fault conditions, the soft-start is reset quickly while UGATE and LGATE change states immediately (<100ns) upon the input drop below falling POR.

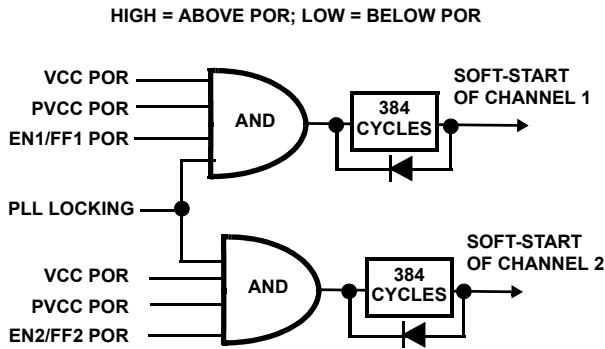

FIGURE 23. SOFT-START INITIALIZATION LOGIC

The enable pin can be used as a voltage monitor and to set the desired hysteresis with an internal 30µA sinking current going through an external resistor divider. The sinking current is disengaged after the system is enabled. This feature is especially designed for applications that require higher input rail POR for better undervoltage protection. For example, in 12V applications,  $R_{UP} = 53.6k$  and  $R_{DOWN} = 5.23k$  will set the turn-on threshold ( $V_{EN\_RTH}$ ) to 10.6V and turn-off threshold ( $V_{EN\_FTH}$ ) to 9V, with 1.6V hysteresis ( $V_{EN\_HYS}$ ).

The multiphase system can immediately turn off all ICs under fault conditions of one or more phases by pulling all EN/FF pins low. Thus, no bouncing occurs among channels at fault and no single phase could carry all current and be over stressed.

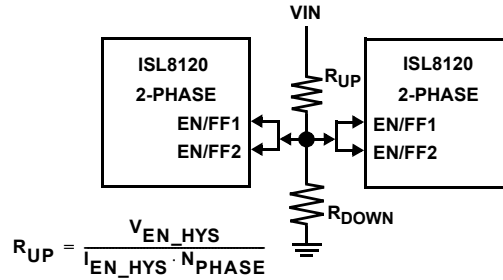

FIGURE 24. TYPICAL 4-PHASE WITH FAULT HANDSHAKE

There is an internal transistor which will pull-down the EN/FF pin under fault conditions. The multiphase system can immediately turn off all ICs under fault conditions of one or more phases by pulling all EN/FF pins low. Thus, no bouncing occurs among channels at fault and no single phase could carry all current and be overstressed. The pull-up resistor ( $R_{UP}$ ) should be scaled to sink no more than 5mA current to the EN/VFF pin. Essentially, the EN/FF pins cannot be directly connected to VCC.

### Voltage Feed-Forward

Other than used as a voltage monitor described in the previous section, the voltages applied to the EN/FF pins are also fed to adjust the amplitude of each channel's individual sawtooth. The amplitude of each channel's sawtooth is set to 1.25 times the corresponding EN/FF voltage upon its enable (above 0.8V). This helps to maintain a constant gain ( $G_M = V_{IN} \cdot D_{MAX} / \Delta V_{RAMP}$ ) contributed by the modulator and the input voltage to achieve optimum loop response over a wide input voltage range. The amplitude of each channel's sawtooth is set to 1.25 times the corresponding EN/VFF voltage upon its enable (above 0.8V). The sawtooth ramp offset voltage is 1V, and the peak of the sawtooth is limited to  $V_{CC} - 1.4V$ . This allows a maximum peak-to-peak amplitude of sawtooth ramp to be  $V_{CC} - 2.4V$ . A constant voltage (0.8V) is fed into the ramp generator to maintain a minimum peak-to-peak ramp.

$$R_{UP} = \frac{V_{EN\_HYS}}{N \cdot I_{EN\_HYS}} \quad R_{DOWN} = \frac{R_{UP} \cdot V_{EN\_REF}}{V_{EN\_FTH} - V_{EN\_REF}}$$

Where N is number of EN/FF pins connected together

$$V_{EN\_FTH} = V_{EN\_RTH} - V_{EN\_HYS}$$

$$\Delta V_{RAMP} = \text{LIMIT}(V_{CC\_FF} \times G_{RAMP}, V_{CC} - 1.4V - V_{RAMP\_OFFSET})$$

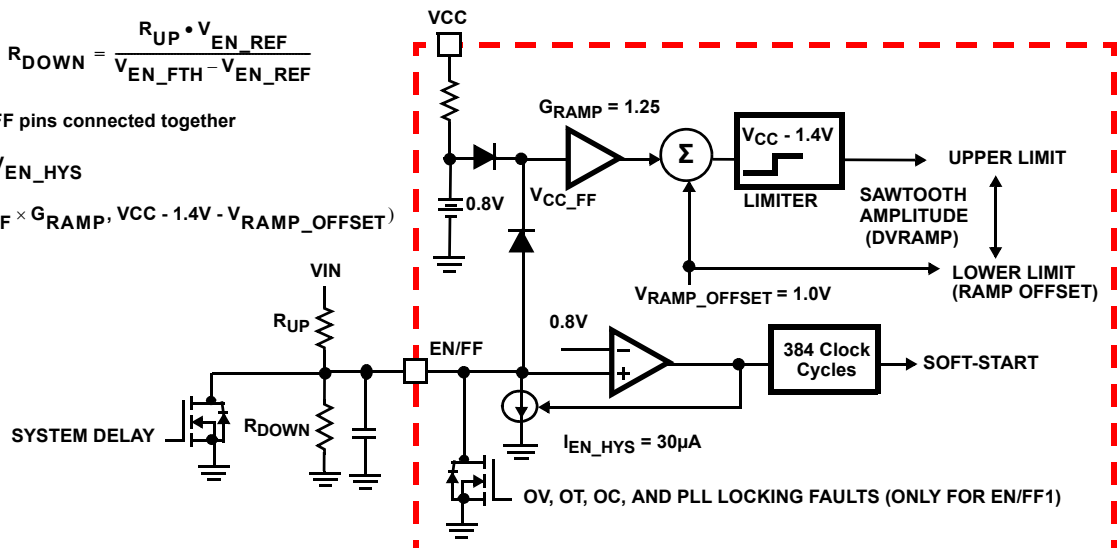

FIGURE 25. SIMPLIFIED ENABLE AND VOLTAGE FEEDFORWARD CIRCUIT

With  $V_{CC} = 5.4V$ , the ramp has an allowable maximum peak-to-peak voltage of 3V and minimum of 1V. Therefore, the feed-forward voltage effective range is typically 3x.

A 384 cycle delay is added after the system reaches its rising POR and prior to the soft-start. The RC timing at the EN/FF pin should be sufficiently small to ensure that the input bus reaches its static state and the internal ramp circuitry stabilizes before soft-start. A large RC could cause the internal ramp amplitude not to synchronize with the input bus voltage during output start-up or when recovering from faults. It is recommended to use an open drain or open collector to gate this pin for any system delay, as shown in [Figure 25](#).

**Soft-Start**

The ISL8120 has two independent digital soft-start circuitry with fixed 1280 switching cycles. The soft-start time is inversely proportional to the switching frequency and is determined by the 1280-cycle digital counter. Refer to [Figure 26](#). The full soft-start time from 0V to 0.6V can be estimated using [Equation 1](#).

$$t_{SS} = \frac{1280}{f_{SW}} \quad (EQ. 1)$$

The ISL8120 has the ability to work under a precharged output (see [Figure 27](#)). The output voltage would not be yanked down during precharged start-up. If the precharged output voltage is greater than the final target level but lowered to 120% setpoint, the switching will not start until the FB voltage reduces to the internal soft-start signal or the end of the soft-start is declared (see [Figure 28](#)).

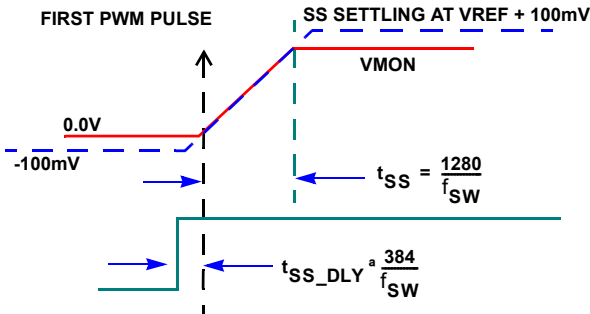

FIGURE 26. SOFT-START WITH  $V_{OUT} = 0V$

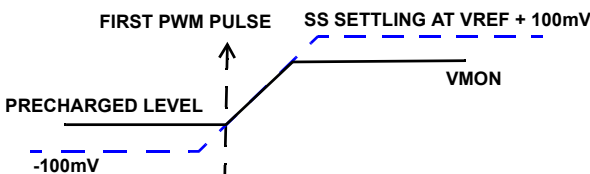

FIGURE 27. SOFT-START WITH  $V_{OUT} = UV$

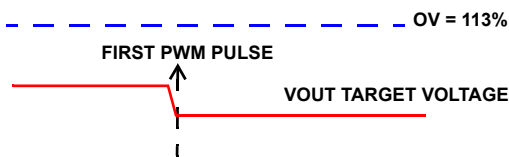

FIGURE 28. SOFT-START WITH  $V_{OUT}$  BELOW OV BUT ABOVE FINAL TARGET VOLTAGE

**Power-Good**

Both channels share the same PGOOD output. Either of the channels indicating out-of-regulation will pull-down the PGOOD pin. The power-good comparators monitor the voltage on the VMON pins. The trip points are shown in [Figure 29](#). PGOOD will not be asserted until after the completion of the soft-start cycle of both channels. States of both EN/FF1 and EN/FF2 have impact on the PGOOD signal. If one of the VMON pins' voltage is out of the threshold window, PGOOD will not pull low until the fault presents for three consecutive clock cycles.

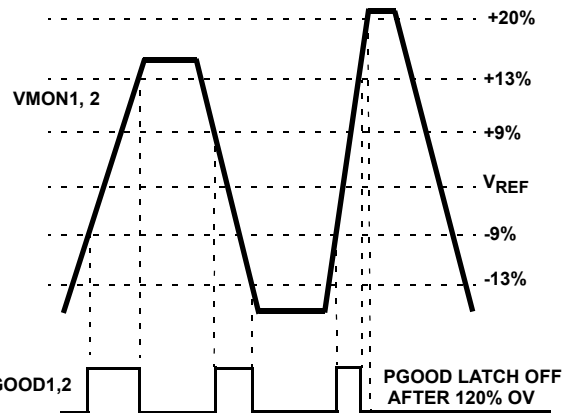
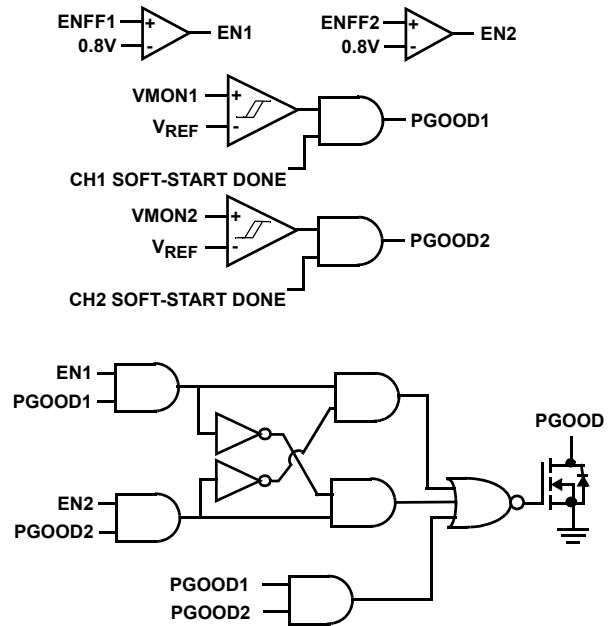

FIGURE 29. POWER-GOOD THRESHOLD WINDOW

**Overvoltage and Undervoltage Protection**

The Overvoltage (OV) and Undervoltage (UV) protection circuitry monitor the voltage on the VMON pins.

OV protection is active upon VCC POR. An OV condition (>120%) would latch IC off (the high-side MOSFET to latch off permanently; the low-side MOSFET turns on immediately at the time of OV trip and then turns off after the VMON drops below 87%). The EN/FF and PGOOD are also latched low at OV event. The latch condition can be reset only by recycling VCC. In

Dual/DDR mode, each channel is responsible for its own OV event with the corresponding VMON as the monitor. In multiphase mode, both channels respond simultaneously when either triggers an OV event.

There is another non-latch OV protection (113% of target level). At the condition of EN/FF low and the output over 113% OV, the lower side MOSFET will turn on until the output drops below 87%. This is to protect the overall power trains in case of only one channel of a multiphase system detecting OV. The low-side MOSFET always turns on at the conditions of EN/FF = LOW and the output voltage above 113% (all VMON pins and EN/FF pins are tied together) and turns off after the output drops below 87%. Thus, in a high phase count application (Multiphase Mode), all cascaded ICs can latch off simultaneously via the EN/FF pins (EN/FF pins are tied together in multiphase mode), and each IC shares the same sink current to reduce the stress and eliminate the bouncing among phases.

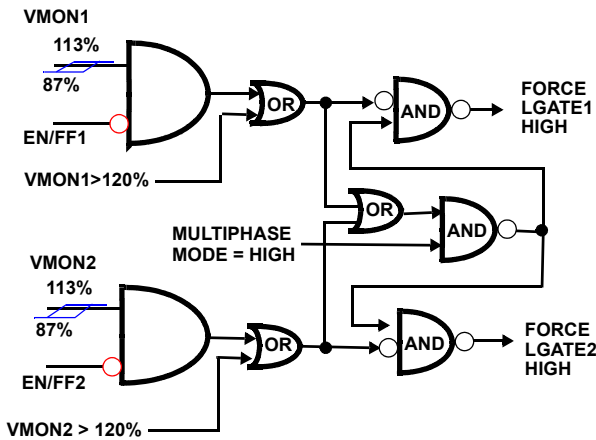

FIGURE 30. FORCE LGATE HIGH LOGIC

The UV functionality is not enabled until the end of soft-start. In a UV event, if the output drops below -13% of the target level due to some reason (cases when EN/FF is not pulled low) other than OV, OC, OT, and PLL faults, the lower MOSFETs will turn off to avoid any negative voltage ringing.

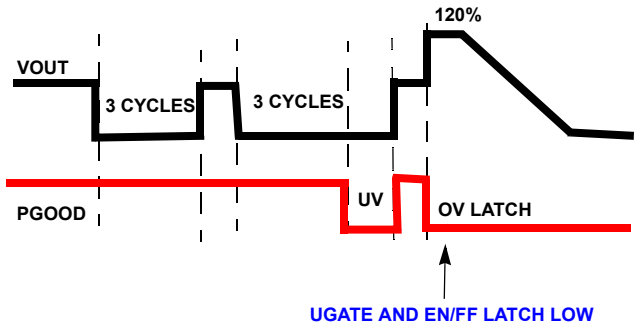

FIGURE 31. PGOOD TIMING UNDER UV AND OV

### PRE-POR Overvoltage Protection (PRE-POR-OVP)

When both the  $V_{CC}$  and  $PVCC$  are below PORs (not including EN POR), the UGATE is low and LGATE is floating (high impedance). EN/VFF has no control on LGATE when  $V_{CC}$  and  $PVCC$  are below their PORs. When  $V_{CC}$  and  $PVCC$  are above their PORs, the LGATE would not be floating, however, toggling with its PWM pulses. An internal 10k $\Omega$  resistor, connected in between PHASE and LGATE nodes, implements the PRE-POR-OVP circuit. The output of the converter that is equal to phase node voltage via output inductors is then effectively clamped to the low-side MOSFET's gate threshold voltage, which provides some protection to the load if the upper MOSFET(s) is shorted during start-up, shutdown, or normal operations. For complete protection, the low-side MOSFET should have a gate threshold that is much smaller than the maximum voltage rating of the load.

The PRE-POR-OVP works against prebiased start-up when precharged output voltage is higher than the threshold of the low-side MOSFET, however, it can be disabled by placing a resistor from LGATE to ground. The resistor value can be estimated from Equation 2.

$$R < \frac{10k}{\frac{V_{pre-biased(max)}}{V_{th(min)}} - 1} \quad (EQ. 2)$$

The resistor value should be as large as possible to minimize power dissipation, while providing sufficient margin for the internal 10k $\Omega$  and MOSFET's  $V_{th}$  tolerances. For example, a 2k $\Omega$  resistor is recommended for applications using logic-level MOSFET with the maximum prebiased voltage less than 5V.

### Over-Temperature Protection (OTP)

When the junction temperature of the IC is greater than +150 $^{\circ}$ C (typically), both EN/FF pins pull low to inform other cascaded channels via their EN/FF pins. All connected EN/FFs stay low and release after the IC's junction temperature drops below +125 $^{\circ}$ C (typically), with a +25 $^{\circ}$ C hysteresis (typical).

### Inductor Current Sensing

The ISL8120 supports inductor DCR sensing, MOSFET's  $r_{DS(ON)}$  sensing, or resistive sensing techniques. The circuits shown in Figures 32, 33, and 34 represent one channel of the controller. This circuitry is identical for both channels.

Note that the common-mode input voltage range of the current sense amplifiers is  $V_{CC} - 1.8V$ . Therefore, the  $r_{DS(ON)}$  sensing must be used for applications with output voltage greater than  $V_{CC} - 1.8V$ . For example, when  $V_{CC} = 5.4V$ , the inductor DCR and the resistive sensing configurations can be used for output voltage less than 3V. For higher output voltage,  $r_{DS(ON)}$  sensing configuration must be used.

**INDUCTOR DCR SENSING**

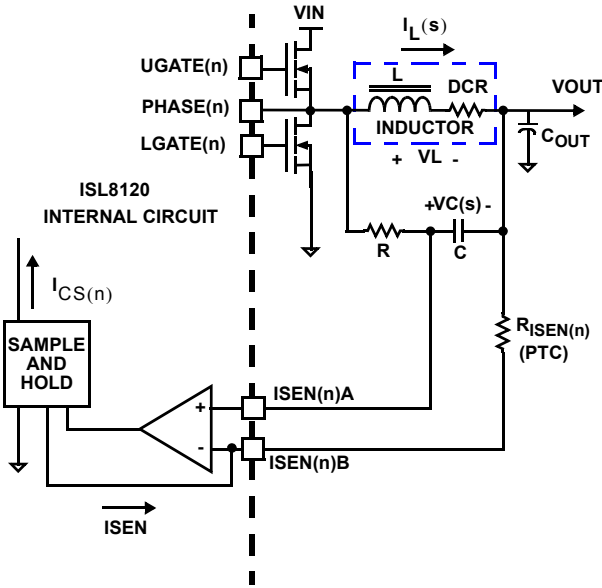

**FIGURE 32. DCR SENSING CONFIGURATION**

An inductor’s winding is characteristic of a distributed resistance as measured by the DCR (Direct Current Resistance) parameter. Consider the inductor DCR as a separate lumped quantity, as shown in [Figure 32](#). The inductor current,  $I_L$ ; will also pass through the DCR. [Equation 3](#) shows the s-domain equivalent voltage across the inductor  $V_L$ .

$$V_L = I_L \cdot (s \cdot L + DCR) \tag{EQ. 3}$$

A simple R-C network across the inductor extracts the DCR voltage, as shown in [Figure 32](#). The voltage on the capacitor  $V_C$ , can be shown to be proportional to the inductor current  $I_L$ , see [Equation 4](#).

$$V_C = \frac{(s \cdot \frac{L}{DCR} + 1) \cdot (DCR \cdot I_L)}{(s \cdot RC + 1)} \tag{EQ. 4}$$

If the R-C network components are selected such that the RC time constant ( $= R \cdot C$ ) matches the inductor time constant ( $= L/DCR$ ), the voltage across the capacitor  $V_C$  is equal to the voltage drop across the DCR, i.e., proportional to the inductor current. The value of R should be as small as feasible for best signal-to-noise ratio. Make sure the resistor package size is appropriate for the power dissipated and include this loss in efficiency calculations. In calculating the minimum value of R, the average voltage across C (which is the average  $I_L DCR$  product) is small and can be neglected. Therefore, the minimum value of R may be approximated using [Equation 5](#).

$$R_{min} = \frac{D \cdot (V_{IN-max} - V_{OUT})^2 + (1-D) \cdot V_{OUT}^2}{k \cdot P_{R-pkg} \cdot \delta_P} \tag{EQ. 5}$$

Where  $P_{R-pkg}$  is the maximum power dissipation specification for the resistor package and  $\delta_P$  is the derating factor for the same parameter (eg.:  $P_{R-pkg} = 0.063W$  for 0402 package,  $\delta_P = 80\%$  at  $+85^\circ C$ ). k is the margin factor, also to limit

temperature raise in the resistor package, recommend using 0.4. Once  $R_{min}$  has been calculated, solve for the maximum value of C using [Equation 6](#) and choose the next-lowest readily available value. Then substitute the chosen value into the same equation and recalculate the value of R. Choose the 1% resistor standard value closest to this recalculated value of R.

$$C_{max} = \frac{L}{R_{min} \cdot DCR} \tag{EQ. 6}$$

For example, when  $V_{IN\_MAX} = 14.4V$ ,  $V_{OUT} = 2.5V$ ,  $L = 1\mu H$  and  $DCR = 1.5m\Omega$ , with 0402 package [Equation 5](#) yields  $R_{MIN}$  of  $1476\Omega$  and [Equation 6](#) yields  $C_{MAX}$  of  $0.45\mu F$ . By choosing  $0.39\mu F$  and recalculating the resistor it yields  $1.69k\Omega$ .

With the internal low-offset current amplifier, the capacitor voltage  $V_C$  is replicated across the sense resistor  $R_{ISEN}$ . Therefore, the current out of ISEN(n)B pin,  $I_{SEN}$ , is proportional to the inductor current. After 175ns blanking period with respect to the falling edge of the PWM pulse of each channel, the  $I_{SEN}$  current is filtered and sampled for 175ns. The sampling current  $I_{CS}$  then can be derived as shown by [Equation 7](#):

$$I_{CS} = \frac{(I_L + \frac{V_{OUT}}{L} \cdot (\frac{1-D}{2f_{SW}} - t_{MIN\_OFF})) \cdot DCR}{R_{ISEN}} \tag{EQ. 7}$$

Where  $I_L$  is the inductor DC current,  $f_{SW}$  is the switching frequency, and  $t_{MIN\_OFF}$  is 350ns.

**Resistive Sensing**

For accurate current sense, a dedicated current-sense resistor  $R_{SENSE}$  in series with the output inductor can serve as the current sense element (see [Figure 33](#)). This technique is more accurate, however, reduces overall converter efficiency due to the additional power loss on the current sense element  $R_{SENSE}$ .

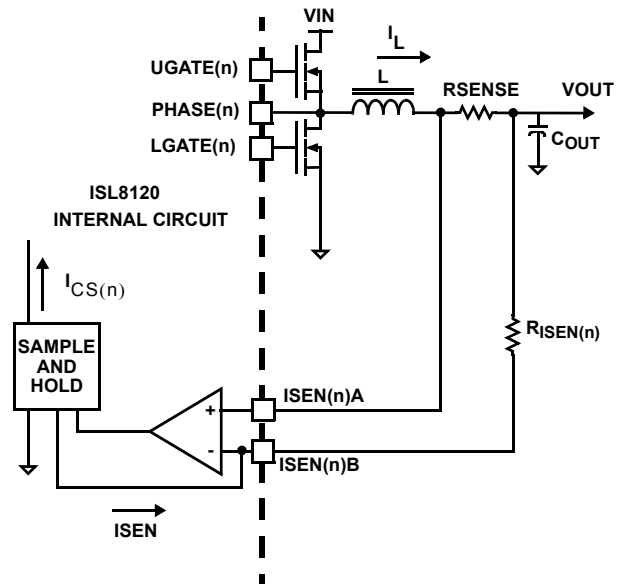

**FIGURE 33. SENSE RESISTOR IN SERIES WITH INDUCTOR**

[Equation 8](#) shows the sampling current,  $I_{CS}$ , when using sensing resistor

$$I_{CS} = \frac{\left( I_L + \frac{V_{OUT}}{L} \cdot \left( \frac{1-D}{2f_{SW}} - t_{MIN\_OFF} \right) \right) \cdot R_{SENSE}}{R_{ISEN}} \quad (\text{EQ. 8})$$

Similar to DCR current sensing approach, the resistive sensing approach can be used with output voltage less than  $V_{CC} - 1.8V$ .

### MOSFET $r_{DS(ON)}$ SENSING

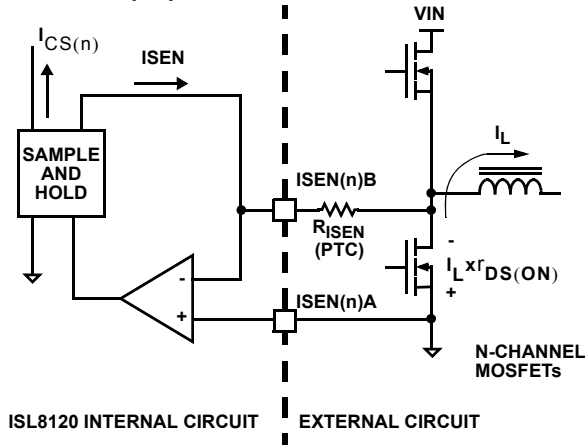

FIGURE 34. MOSFET  $r_{DS(ON)}$  CURRENT-SENSING CIRCUIT

The controller can also sense the channel load current by sampling the voltage across the synchronous MOSFET  $r_{DS(ON)}$  (see [Figure 34](#)). The amplifier is ground-referenced by connecting the ISEN(n)A pin to the source of the synchronous MOSFET. ISEN(n)B pin is connected to the synchronous MOSFET'S drain through the current sense resistor  $R_{ISEN}$ . The voltage across  $R_{ISEN}$  is equivalent to the voltage drop across the  $r_{DS(ON)}$  of the lower MOSFET while it is conducting. The resulting current out of the ISEN(n)B pin is proportional to the channel current  $I_L$ .

[Equation 9](#) shows the sampling current,  $I_{CS}$ , when using MOSFET  $r_{DS(ON)}$  sensing.

$$I_{CS} = \frac{\left( I_L + \frac{V_{OUT}}{L} \cdot \left( \frac{1-D}{2f_{SW}} - t_{MIN\_OFF} \right) \right) \cdot r_{DS(ON)}}{R_{ISEN}} \quad (\text{EQ. 9})$$

Both inductor DCR and MOSFET  $r_{DS(ON)}$  value will increase as the temperature increases. Therefore the sensed current will increase as the temperature of the current sense element increases. In order to compensate the temperature effect on the sensed current signal, a Positive Temperature Coefficient (PTC) resistor can be selected for the sense resistor  $R_{ISEN}$ .

### Overcurrent Protection

For overload and hard short condition, the overcurrent protection reduces the regulator RMS output current much less than full load by putting the controller into hiccup mode. A delay time, equal to 3 soft-start intervals, is inserted to allow the disturbance to be cleared out. After the delay time, the controller then initiates a soft-start interval. If the output voltage comes up and returns to the regulation, PGOOD transitions high. If the OC trip is exceeded during the soft-start interval, the controller pulls

EN/VFF low again. The PGOOD signal will remain low and the soft-start interval will be allowed to expire. Another soft-start interval will be initiated after the delay interval. If an overcurrent trip occurs again, this same cycle repeats until the fault is removed.

The OCP function is enabled at start-up. The ISL8120 monitors 2 signals: sampled channel current,  $I_{CS}$  and ISHARE voltage for over current protection.

### CHANNEL CURRENT OCP

Each sampled channel current,  $I_{CS}$ , is compared to  $108\mu A$  (typical) for the OCP trip point. The channel overcurrent trip point can be set by using  $R_{ISEN}$  value such that the overcurrent trip point corresponds to the channel sensing current,  $I_{CS}$ , of  $108\mu A$ . For DCR current sensing, [Equation 7](#), and  $r_{DS(ON)}$  current sensing, [Equation 9](#), the  $R_{ISEN}$  can be estimated from [Equations 10](#) and [11](#), respectively.

$$R_{ISEN} = \frac{\left( I_{OC} + \frac{V_{OUT}}{L} \cdot \left( \frac{1-D}{2f_{SW}} - t_{MIN\_OFF} \right) \right) \cdot DCR}{108\mu A} \quad (\text{EQ. 10})$$

$$R_{ISEN} = \frac{\left( I_{OC} + \frac{V_{OUT}}{L} \cdot \left( \frac{1-D}{2f_{SW}} - t_{MIN\_OFF} \right) \right) \cdot r_{DS(ON)}}{108\mu A} \quad (\text{EQ. 11})$$

Without temperature compensation, the OCP trip point should be evaluated based on the DCR or MOSFET  $r_{DS(ON)}$  values at the maximum device's temperature.

While configured as multiphase operation ( $V_{SEN2} > V_{CC} - 400mV$ ), the channel OCP has 7 clock cycles delay before entering hiccup mode.

In dual-output operation, the 7-clock cycle delay on Channel 2 is bypassed so the circuit responds to over current condition immediately. In this mode, the 7-clock cycle delay in Channel 1 is still active. The fast OCP response on Channel 1 will rely on the OCP on the ISHARE pin where the voltage on this pin represents the Channel 1 current.

### ISHARE OCP

Refer to the block diagram, ISHARE pin sources out a current IAVG\_CS with  $15\mu A$  offset. In the 2-phase mode, IAVG\_CS is the average of both Channels 1 and 2 sampled currents as calculated in [Equation 12](#).

$$IAVG\_CS = \frac{ICS1 + ICS2}{2} \quad (\text{EQ. 12})$$

While in the dual-output mode, IAVG\_CS is a copy of Channel 1's sampled current.

In multiphase operation, the VISHARE represents the average current of all ISL8120 and compares with the ISHARE pin precision 1.2V threshold to determine the overcurrent condition. At the same time, each channel has additional overcurrent trip point at  $108\mu A$  with 7-cycle delay for channel overcurrent protection. This scheme helps protect against loss of channel(s) in multi-phase mode so that no single channel could carry excessive current in such event. With  $R_{ISHARE} = 10k\Omega$ , It would

make the channel current OCP and ISHARE OCP trip at the same over current level;  $(108\mu\text{A} + 15\mu\text{A}) \times 10\text{k}\Omega = 1.23\text{V}$ .

Note that it is not necessary for the  $R_{\text{ISHARE}}$  to be scaled to trip at the same level as the  $108\mu\text{A}$  OCP comparator if the application allows. For instance, when Channel 1 operates independently, the OC trip set by 1.2V comparator can be lower than 108A trip point.

To set the ISHARE OCP in the multiphase configuration, the  $R_{\text{ISEN}}$  must be determined first by using [Equations 10](#) or [11](#). The IOC in [Equations 10](#) or [11](#) is overcurrent for each phase, which is approximately  $\text{IOC}_{\text{total}}/\text{number of phases}$ . Upon determining  $R_{\text{ISET}}$ , [Equations 7](#), [8](#), [9](#) and [11](#) can be used to determine ISHARE OCP, as shown in [Equation 12](#).

$$R_{\text{ISHARE}} = \frac{1.2\text{V}}{N_{\text{CNTL}} \sum_{i=1} (I_{\text{AVG\_CS}} + 15\mu\text{A})_i} \quad (\text{EQ. 13})$$

$$R_{\text{ISET}} = R_{\text{ISHARE}} \cdot N_{\text{CNTL}}$$

Where  $N_{\text{CNTL}}$  is the number of the ISL8120 controllers in parallel or multiphase operations.

For the  $R_{\text{ISEN}}$  chosen for OCP setting, the final value is usually higher than the number calculated from [Equation 9](#). The reason for which is practical, especially for low DCR applications since the PCB and inductor pad soldering resistance would have large effects in total impedance, affecting the DCR voltage to be sensed.

## Current Sharing Loop

When the ISL8120 operates in 2-phase mode ( $V_{\text{SEN2-}}$  is pulled within  $V_{\text{CC}} - 400\text{mV}$ ), the current control loop keeps Channel 1 and Channel 2 currents in balance. The sensed currents from both channels are combined to create an average current reference ( $I_{\text{AVG}}$ ), which represents average current of both channel currents. The signal  $I_{\text{AVG}}$  is then subtracted from the individual sensed current ( $I_{\text{CS1}}$  or  $I_{\text{CS2}}$ ) to produce a current correction signal for each channel. The block diagram of current sharing control circuit is shown in [Figure 36](#).

When both channels operate independently, the average function is disabled, and the current correction block of Channel 2 is also disabled. The  $I_{\text{AVG\_CS}}$  is Channel 1 sensed current  $I_{\text{CS1}}$ . Channel 1 makes any necessary current correction by comparing the voltages at ISET and ISHARE pins (for 3-phase, two ISL8120s configuration).

When the share bus does not connect to other ICs, the ISET and ISHARE pins can be shorted together and grounded via a single resistor to ensure zero share error.

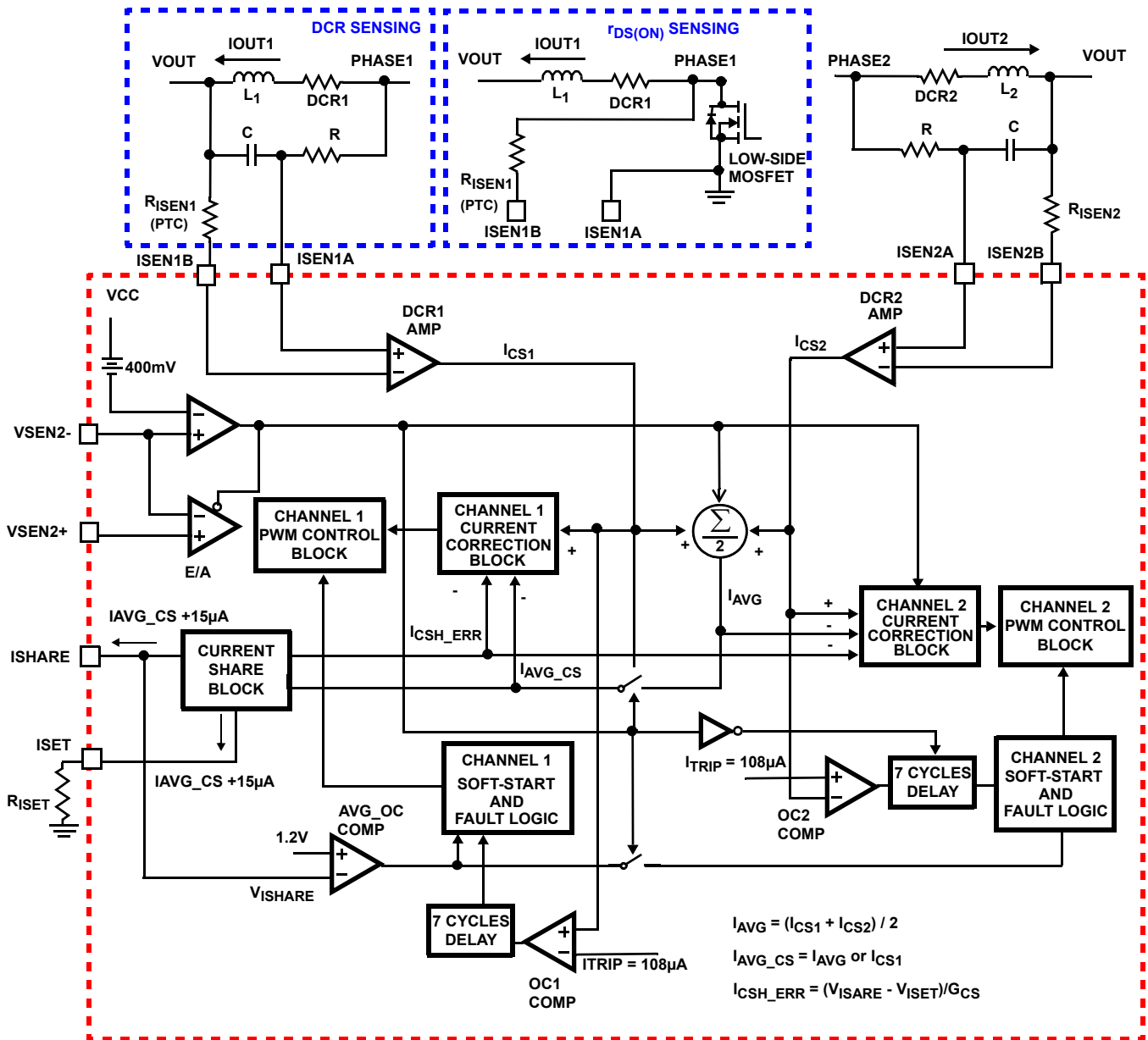

FIGURE 35. SIMPLIFIED CURRENT SAMPLING AND OVERCURRENT PROTECTION

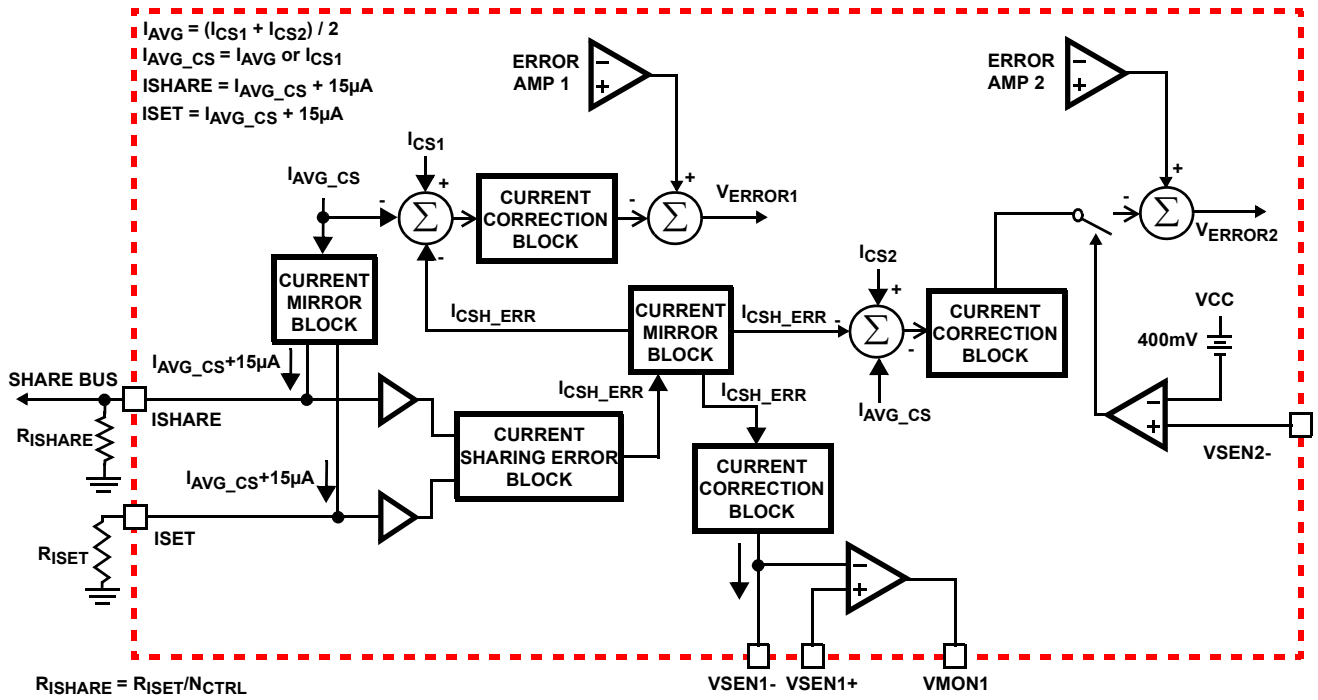

FIGURE 36. SIMPLIFIED CURRENT SHARE AND INTERNAL BALANCE IMPLEMENTATION

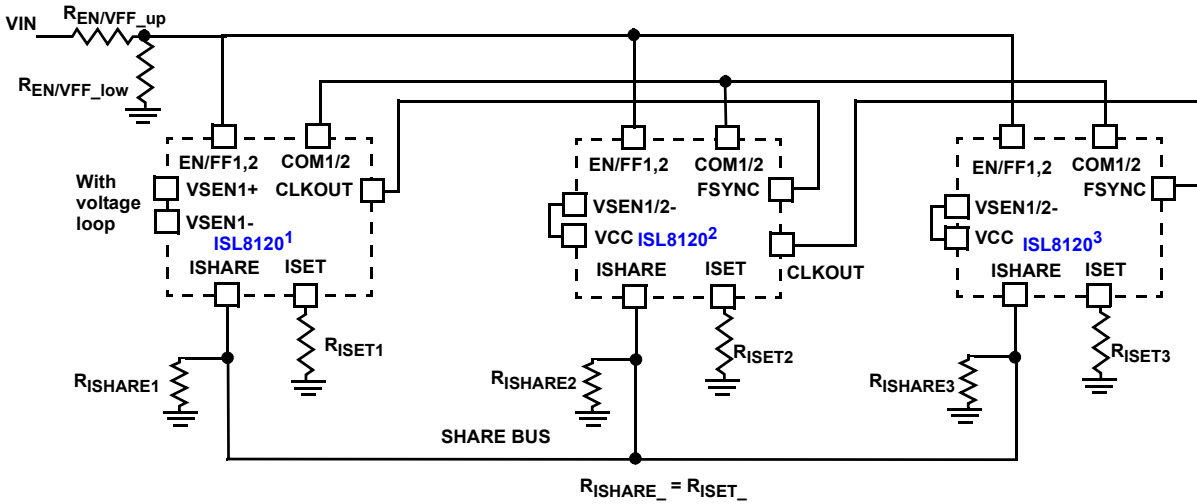

FIGURE 37. SIMPLIFIED 6-PHASE SINGLE OUTPUT IMPLEMENTATION

**CURRENT SHARE CONTROL IN MULTIPHASE SINGLE OUTPUT WITH SHARED COMP VOLTAGE**

In multiphase/multi-IC implementation with one single error amplifier for the voltage loop, all COMP pins must be tied together. Therefore, all other channels' error amplifiers that are not used in voltage loop should be disabled with their corresponding VSEN- pulled to VCC, as shown in [Figure 37 on page 31](#).

For current sharing purposes, all ISHARE pins must also be tied together. The share bus (V<sub>ISHARE</sub>) represents the average current of all ISL8120s connected to the same ISHARE bus. The ISHARE pin sources a copy of the I<sub>AVG\_CS</sub> with 15µA offset (I<sub>AVG\_CS</sub> equals to I<sub>AVG</sub> or I<sub>CS1</sub> depending upon the configuration). The ISET pin also sources out a copy of I<sub>AVG\_CS</sub> with 15µA offset. The voltage on ISET pin represents individual current for each IC. The current share error signal (I<sub>CSH\_ERR</sub>) is then fed into the current correction block to adjust each channel's PWM pulse accordingly.

If one single external resistor is used as R<sub>ISHARE</sub> connecting the ISHARE bus to ground for all the ICs in parallel, R<sub>ISHARE</sub> should be set equal to R<sub>ISET</sub>/N<sub>CTRL</sub> (where N<sub>CTRL</sub> is the number of the ISL8120 controllers in parallel or multiphase operations), and the share bus voltage (V<sub>ISHARE</sub>) set by the R<sub>ISHARE</sub> represents the average current of all channels. R<sub>ISHARE</sub> can also be set by putting one resistor in each IC's ISHARE pin and using the same value with R<sub>ISET</sub> (R<sub>ISHARE</sub> = R<sub>ISET</sub>), which results in the total equivalent resistance value as R<sub>ISET</sub>/N<sub>CTRL</sub>.

**CURRENT SHARE CONTROL LOOP IN MULTI-MODULE WITH INDEPENDENT VOLTAGE LOOP**

The power module controlled by ISL8120 with its own voltage loop can be paralleled to supply one common output load with its integrated master-slave current sharing control, as shown in the [Figure 9 on page 13](#). A resistor R<sub>CSR</sub> need to be inserted between VSEN1- pin and the lower resistor of the voltage sense resistor divider for each module. With this resistor, the correction current sourcing from the VSEN1- pin will create a voltage offset to maintain even current sharing among modules. The recommended value for the VSEN1- resistor R<sub>CSR</sub> is 100Ω and it should not be large in order to keep the unity gain amplifier input pin impedance compatibility. The maximum source current from the VSEN1- pin is 350µA, which is combined with R<sub>CSR</sub> to determine the current sharing regulation range. The generated correction voltage on R<sub>CSR</sub> is suggested to be within 5% of VREF (0.6V) to avoid fault triggering of UV/OV and PGOOD during dynamic events.

It is recommended to have 3 analog signals: CLKOUT-SYNC, ISHARE and EN/FF for communication among the paralleled modules. All the modules are synchronized and the phase shift can also be configured to optimal to reduce the input current ripple by interleaving effects. The connections of these three wires allows the system to be started at the same time and achieve good current balance in start-up without overcurrent trip.

**Internal Series Linear and Power Dissipation**

The VIN pin is connected to PVCC with an internal series linear regulator. The PVCC and VIN pins should have the recommended

bypass ceramic capacitors (10µF) connected to GND for proper operation. The internal linear regulator's input (VIN) can range between 3V to 22V. The PVCC pin is the output of the internal linear regulator and it provides power for both the internal MOSFET drivers through the PVCC pin. The VCC pin is the bias input for the IC small signal analog circuitry. By connecting PVCC to the VCC pin, the internal linear regulator supplies bias power to VCC. The VCC pin should be connected to the PVCC pin with an RC filter to prevent high frequency driver switching noise from the analog circuitry. When VIN drops below 5.0V, the pass element will saturate; PVCC will track VIN with a dropout of the linear regulator. When used with an external 5V supply, the VIN pin is recommended to be tied directly to PVCC.

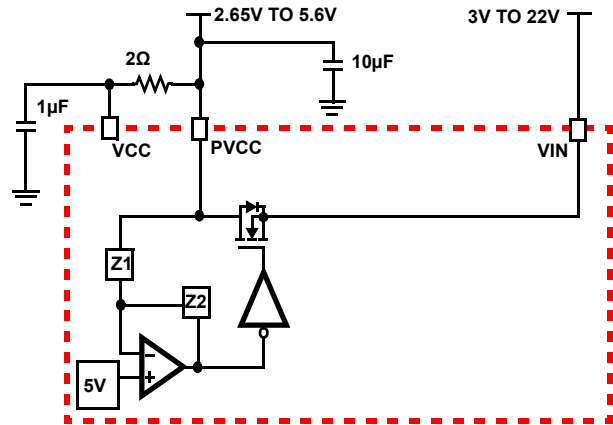

FIGURE 38. INTERNAL REGULATOR IMPLEMENTATION

The LDO is capable of supplying 250mA with regulated 5.4V output. In 3.3V input applications, when the VIN pin voltage is 3V, the LDO can still supply 150mA while maintaining LDO output voltage higher than VCC falling threshold to keep IC operating. [Figure 39](#) shows the LDO voltage drop under different load current. However, its thermal capability should not be exceeded. The power dissipation inside the IC could be estimated with [Equation 14](#).

$$P_{IC} = (VIN - PVCC) \cdot I_{VIN} + P_{DR} \tag{EQ. 14}$$

$$I_{VIN} = \left( \frac{Q_{G1} \cdot N_{Q1}}{V_{GS1}} + \frac{Q_{G2} \cdot N_{Q2}}{V_{GS2}} \right) \cdot PVCC \cdot f_{SW} + I_{Q\_VIN}$$

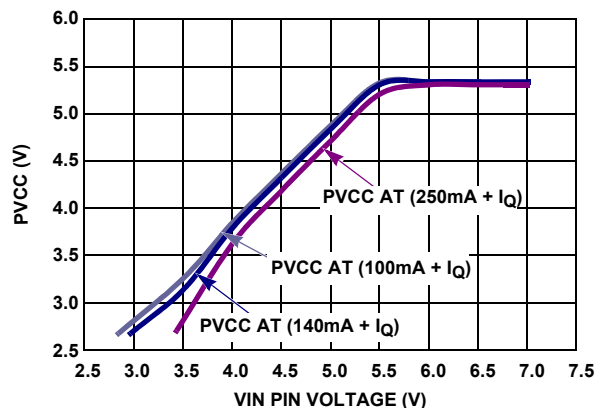

FIGURE 39. PVCC vs VIN VOLTAGE

$$P_{DR} = P_{DR\_UP} + P_{DR\_LOW}$$

$$P_{DR\_UP} = \left( \frac{R_{HI1}}{R_{HI1} + R_{EXT1}} + \frac{R_{LO1}}{R_{LO1} + R_{EXT1}} \right) \cdot \frac{P_{Qg\_Q1}}{2}$$

$$P_{DR\_LOW} = \left( \frac{R_{HI2}}{R_{HI2} + R_{EXT2}} + \frac{R_{LO2}}{R_{LO2} + R_{EXT2}} \right) \cdot \frac{P_{Qg\_Q2}}{2}$$

$$P_{Qg\_Q1} = \frac{Q_{G1} \cdot PVCC^2}{V_{GS1}} \cdot f_{SW} \cdot N_{Q1}$$

$$P_{Qg\_Q2} = \frac{Q_{G2} \cdot PVCC^2}{V_{GS2}} \cdot f_{SW} \cdot N_{Q2}$$

$$R_{EXT1} = R_{G1} + \frac{R_{GI1}}{N_{Q1}} \quad R_{EXT2} = R_{G2} + \frac{R_{GI2}}{N_{Q2}}$$

(EQ. 15)

Where the gate charge ( $Q_{G1}$  and  $Q_{G2}$ ) is defined at a particular gate to source voltage ( $V_{GS1}$  and  $V_{GS2}$ ) in the corresponding MOSFET datasheet;  $I_{Q\_VIN}$  is the driver's total quiescent current with no load at drive outputs;  $N_{Q1}$  and  $N_{Q2}$  are number of upper and lower MOSFETs, respectively.

To keep the IC within its operating temperature range, an external power resistor could be used in series with VIN pin to bring the heat out of the IC, or an external LDO could be used when necessary.

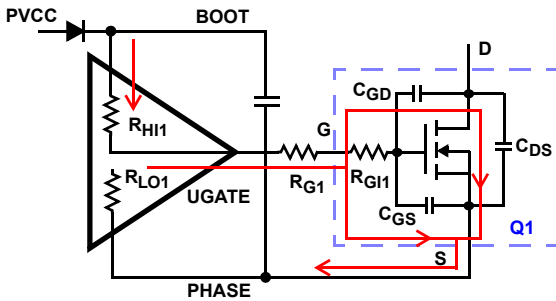

FIGURE 40. TYPICAL UPPER-GATE DRIVE TURN-ON PATH

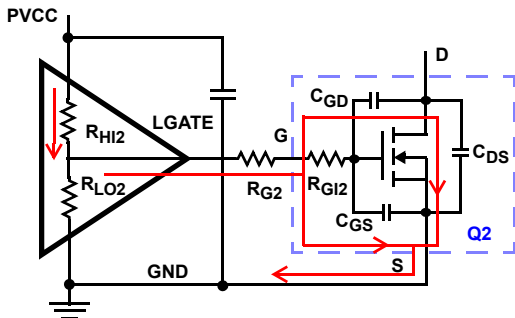

FIGURE 41. TYPICAL LOWER-GATE DRIVE TURN-ON PATH

### Oscillator

The Oscillator is a sawtooth waveform, providing for leading edge modulation with 350ns minimum PWM off-time. The oscillator (Sawtooth) waveform has a DC offset of 1.0V. Each channel's peak-to-peak of the ramp amplitude is set proportional the voltage applied to its corresponding EN/FF pin. See ["Voltage Feed-Forward" on page 24](#).

### Frequency Synchronization and Phase Lock Loop

The FSYNC pin has two primary capabilities: fixed frequency operation and synchronized frequency operation. By tying a resistor ( $R_{FSYNC}$ ) to GND from the FSYNC pin, the switching frequency can be set at any frequency between 150kHz and 1.5MHz. The value of  $R_{FSYNC}$  can be estimated using [Equation 16](#). The frequency setting curve shown in [Figure 42](#) is also provided to assist in selecting the correct value for  $R_{FSYNC}$ .

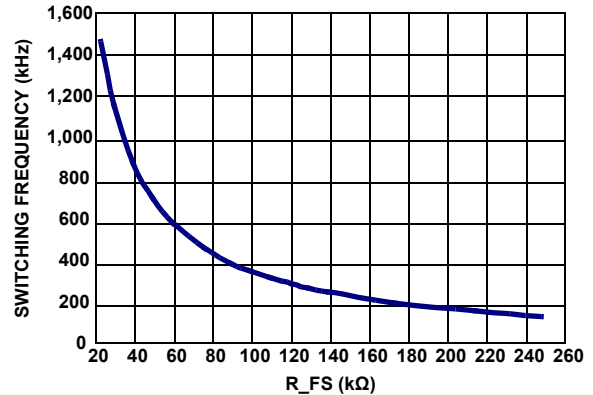

FIGURE 42.  $R_{FS}$  vs SWITCHING FREQUENCY

$$R_{FSYNC}[k\Omega] = 4.671 \times 10^4 \cdot f_{SW}[kHz]^{-1.04}$$

(EQ. 16)

By connecting the FSYNC pin to an external square pulse waveform (such as the CLOCK signal, typically 50% duty cycle from another ISL8120), the ISL8120 will synchronize its switching frequency to the fundamental frequency of the input waveform. The maximum voltage to the FSYNC pin is  $V_{CC} + 0.3V$ . The frequency synchronization feature will synchronize the leading edge of CLKOUT signal with the falling edge of Channel 1's PWM clock signal. The CLKOUT is not available until the PLL locks.

The locking time is typically 130μs for  $f_{SW} = 500kHz$ . EN/FF1 is released for a soft-start cycle until the FSYNC stabilized and the PLL is in locking. The PLL circuits control only EN/FF1, and control Channel 2's soft-start instead of EN/FF2. Therefore, it is recommended to connect all EN/FF pins together in multiphase configuration.

The loss of a synchronization signal for 13 clock cycles causes the IC to be disabled until the PLL returns locking, at which point a soft-start cycle is initiated and normal operation resumes. Holding FSYNC low will disable the IC.

### Differential Amplifier for Remote Sense

The differential remote sense buffers help compensate the droop due to load on the positive and negative rails and maintain the high system accuracy of  $\pm 0.6\%$ . They have precision unity gain resistor matching networks, which has an ultra low offset of 1mV.

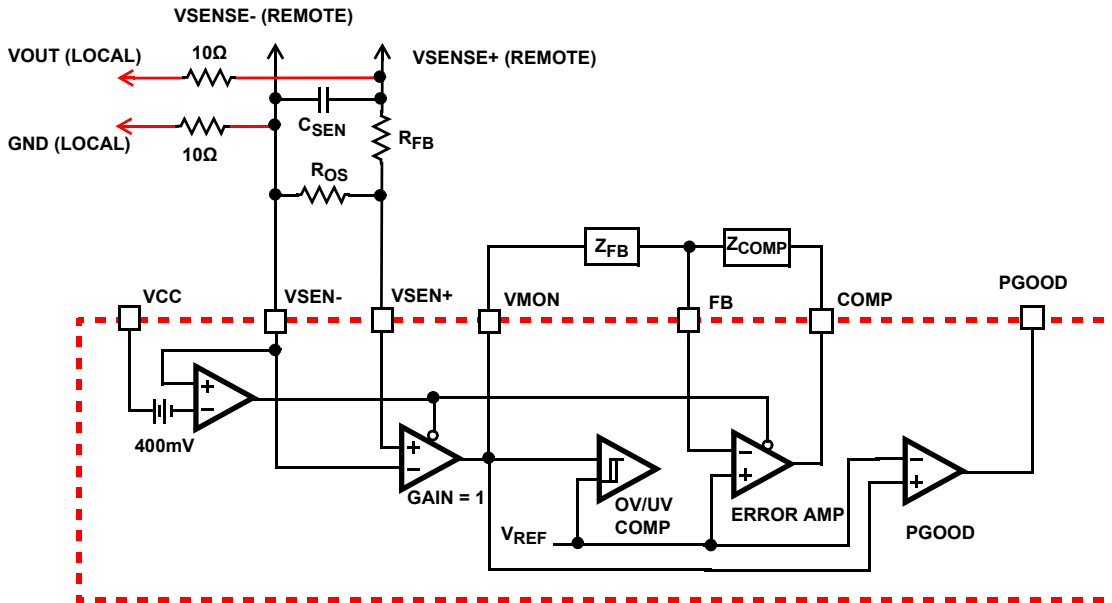

FIGURE 43. SIMPLIFIED REMOTE SENSING IMPLEMENTATION

The output of the remote sense buffer is connected directly to the internal OV/UV comparator. As a result, a resistor divider should be placed on the input of the buffer for proper regulation, as shown in Figure 43. The VMON pin should be connected to the FB pin by a standard feedback network. The output voltage can be set by using Equation 17:

$$V_{OUT} = V_{ref} \cdot \left( 1 + \frac{R_{FB}}{R_{OS}} \right) \quad (EQ. 17)$$

To optimize system accuracy, it is highly recommended to include this impedance into calculation and use resistor with resistance as low as possible for the lower leg ( $R_{OS}$ ) of the feedback resistor divider. Note that any RC filter at the inputs of the differential amplifier, will contribute as a pole to the overall loop compensation.

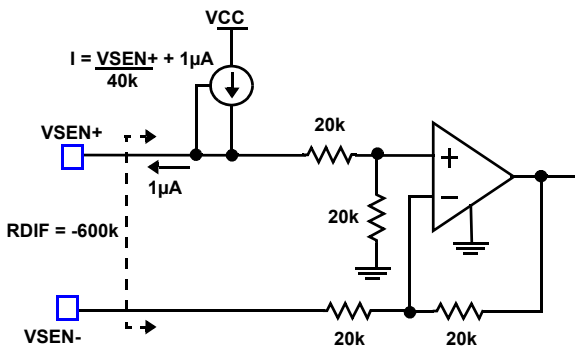

FIGURE 44. EQUIVALENT DIFFERENTIAL AMPLIFIER

The differential remote sense buffer has a precision unity gain resistor matching network, which has an ultra low offset of 1mV. This true remote sensing scheme helps compensate the droop due to load on the positive and negative rails and maintain the high system accuracy of  $\pm 0.6\%$ .

As some applications will not need the differential remote sense, the output of the remote sense buffer can be disabled and be placed in high impedance by pulling VSEN- within 400mV of  $V_{CC}$ .

In such an event, the VMON pin can be used as an additional monitor of the output voltage with a resistor divider to protect the system against single point of failure, which occurs in the system using the same resistor divider for the UV/OV comparator and the output regulation. The resistor divider ratio should be the same as the one for the output regulation so that the correct voltage information is provided to the OV/UV comparator. Figure 45 shows the differential sense amplifier can be directly used as a monitor without pulling VSEN- high.

### Internal Reference and System Accuracy

The internal reference is set to 0.6V. Including bandgap variation and offset of differential and error amplifiers, it has an accuracy of  $\pm 0.6\%$  over commercial temperature range, and 0.9% over industrial temperature range. While the remote sense is not used, its offset ( $V_{OS\_DA}$ ) should be included in the tolerance calculation. Equations 18 and 19 show the worst case of system accuracy calculation.  $V_{OS\_DA}$  should set to zero when the differential amplifier is in the loop, the differential amplifier's input impedance ( $R_{DIF}$ ) is typically  $-600k\Omega$  with a tolerance of 20% ( $R_{DIF}\%$ ) and can be neglected when  $R_{OS}$  is less than  $100\Omega$ . To set a precision setpoint,  $R_{OS}$  can be scaled by two paralleled resistors.

Figure 46 shows the tolerance of various output voltage regulation for 1%, 0.5%, and 0.1% feedback resistor dividers. Note that the farther the output voltage setpoint away from the internal reference voltage, the larger the tolerance; the lower the resistor tolerance (R%), the tighter the regulation.

$$\%min = (V_{ref} \cdot (1 - Ref\%) - V_{OS\_DA}) \cdot \left( 1 + \frac{R_{FB} \cdot (1 - R\%)}{R_{OSMAX}} \right) \quad (EQ. 18)$$

$$R_{OSMAX} = \frac{1}{\frac{1}{R_{OS} \cdot (1 + R\%)} + \frac{1}{R_{DIF} \cdot (1 + R_{DIF}\%)}}$$

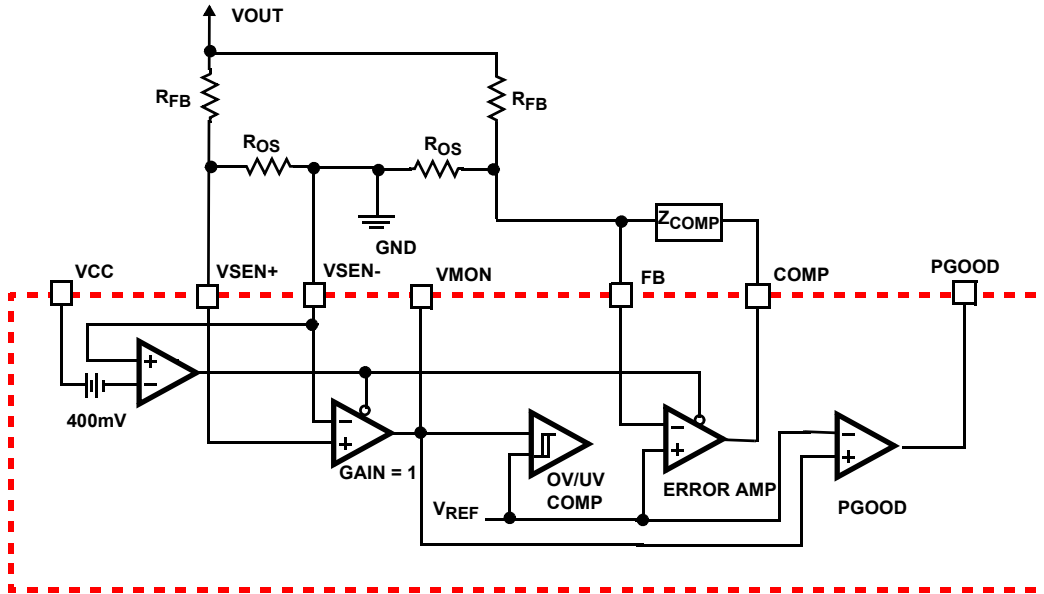

FIGURE 45. DUAL OUTPUT VOLTAGE SENSE FOR SINGLE POINT OF FAILURE PROTECTION

$$\%max = (V_{ref} \cdot (1 - Ref\%) - V_{OS\_DA}) \cdot \left(1 + \frac{R_{FB} \cdot (1 - R\%)}{R_{OSMIN}}\right) \tag{EQ. 19}$$

$$R_{OSMIN} = \frac{1}{\frac{1}{R_{OS} \cdot (1 - R\%)} + \frac{1}{R_{DIF} \cdot (1 - R_{DIF}\%)}}$$

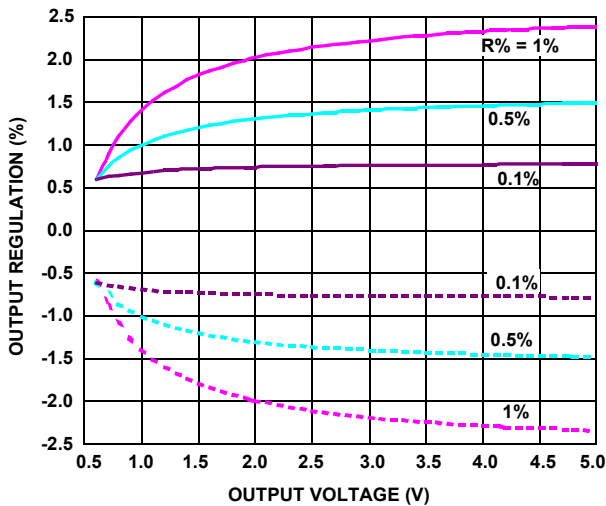

FIGURE 46. OUTPUT REGULATION WITH DIFFERENT RESISTOR TOLERANCE FOR Ref% = ±0.6%

**DDR and Dual Mode Operation**

If the CLKOUT/REFIN is less than 29% of V<sub>CC</sub>, an external soft-start ramp (0.6V) can be in parallel with the Channel 2's internal soft-start ramp for DDR/tracking applications (DDR Mode).

The output voltage (typical VTT output) of Channel 2 tracks with the input voltage (typical VDDQ\*(1+k) from Channel 1) at the CLKOUT/REFIN pin. As for the external input signal and internal

reference signal (ramp and 0.6V), the one with the lowest voltage will be the one to be used as the reference comparing with FB signal. So in DDR configuration, VTT channel should start-up later after its internal soft-start ramp in which way the VTT will track the voltage on REFIN pin derived from VDDQ. This can be achieved by adding more filtering at EN//FF1 compared with EN//FF2.

Since the UV/OV comparator uses the same internal reference 0.6V, to guarantee UV/OV and precharged start-up functions of Channel 2, the target voltage derived from Channel 1 (VDDQ) should be scaled close to 0.6V, and it is suggested to be slightly above (+2%) 0.6V with an external resistor divider, which will have Channel 2 use the internal 0.6V reference after soft-start. Any capacitive load at the REFIN pin should not slow down the ramping of this input 150mV lower than the Channel 2' internal ramp. Otherwise, the UV protection could be fault triggered prior to the end of the soft-start. The start-up of Channel 2 can be delayed to avoid such situation happening, if high capacitive load presents at the REFIN pin for noise decoupling. During shutdown, Channel 2 will follow Channel 1 until both channels drops below 87%, at which point both channels enter UV protection zone. Depending on the loading, Channel 1 might drop faster than Channel 2. To solve this race condition, Channel 2 can either power up from Channel 1 or bridge the Channel 1 with a high current Schottky diode. If the system requires to shutdown both channels when either has a fault, tying EN//FF1 and EN//FF2 will do the job. In DDR mode, Channel 1 delays 60° over Channel 2.

In Dual mode, depending upon the resistor divider level of REFIN from V<sub>CC</sub>, the ISL8120 operates as a dual-PWM controller for two independent regulators with a phase shift, as shown in [Table 2 on page 36](#). The phase shift is latched as V<sub>CC</sub> raises above POR and cannot be changed on the fly.

TABLE 2.

MODE	DECODING REFIN RANGE	PHASE FOR CHANNEL 2 WRT CHANNEL 1	REQUIRED REFIN
DDR	<29% of $V_{CC}$	-60°	0.6V
Dual	29% to 45% of $V_{CC}$	0°	37% $V_{CC}$
Dual	45% to 62% of $V_{CC}$	90°	53% $V_{CC}$
Dual	62% to $V_{CC}$	180°	$V_{CC}$

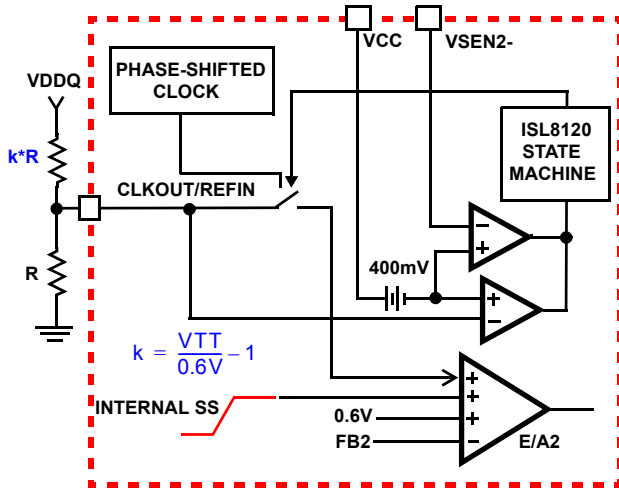

FIGURE 47. SIMPLIFIED DDR IMPLEMENTATION

## Layout Considerations

MOSFETs switch very fast and efficiently. The speed at which the current transitions from one device to another causes voltage spikes across the interconnecting impedances and parasitic circuit elements. These voltage spikes can degrade efficiency, radiate noise into the circuit and lead to device overvoltage stress. Careful component selection, layout and placement minimizes these voltage spikes. Consider, as an example, the turnoff transition of the upper PWM MOSFET. Prior to turnoff, the upper MOSFET was carrying current. During the turnoff, current stops flowing in the upper MOSFET and is picked up by the lower MOSFET. Any inductance in the switched current path generates a large voltage spike during the switching interval. Careful component selection, tight layout of the critical components, and short, wide circuit traces minimize the magnitude of voltage spikes.

There are two sets of critical components in a DC/DC converter using an ISL8120 controller. The power components are the most critical because they switch large amounts of energy. Next, are small signal components that connect to sensitive nodes or supply critical bypassing current and signal coupling.

The power components should be placed first, which include the MOSFETs, input and output capacitors, and the inductors. It is important to have a symmetrical layout for each power train, preferably with the controller located equidistant from each. Symmetrical layout allows heat to be dissipated equally across all power trains. Equidistant placement of the controller to the power trains (it controls through the integrated drivers), helps

keep the gate drive traces equally short, resulting in equal trace impedances and similar drive capability of all sets of MOSFETs.

When placing the MOSFETs, try to keep the source of the upper FETs and the drain of the lower FETs as close as thermally possible. Input high-frequency capacitors,  $C_{HF}$  should be placed close to the drain of the upper FETs and the source of the lower FETs. Input bulk capacitors,  $C_{BULK}$ , case size typically limits following the same rule as the high-frequency input capacitors. Place the input bulk capacitors as close to the drain of the upper FETs as possible and minimize the distance to the source of the lower FETs.

Locate the output inductors and output capacitors between the MOSFETs and the load. The high-frequency output decoupling capacitors (ceramic) should be placed as close as practicable to the decoupling target, making use of the shortest connection paths to any internal planes, such as vias to GND next or on the capacitor solder pad.

The critical small components include the bypass capacitors ( $C_{FILTER}$ ) for VCC and PVCC, and many of the components surrounding the controller including the feedback network and current sense components. Locate the VCC/PVCC bypass capacitors as close to the ISL8120 as possible. It is especially important to locate the components associated with the feedback circuit close to their respective controller pins, since they belong to a high-impedance circuit loop, sensitive to EMI pick-up.

A multi-layer printed circuit board is recommended. Dedicate one solid layer, usually the one underneath the component side of the board, for a ground plane and make all critical component ground connections with vias to this layer. Dedicate another solid layer as a power plane and break this plane into smaller islands of common voltage levels. Keep the metal runs from the PHASE terminal to output inductors short. The power plane should support the input power and output power nodes. Use copper filled polygons on the top and bottom circuit layers for the phase nodes. Use the remaining printed circuit layers for small signal wiring.

## ROUTING UGATE, LGATE AND PHASE TRACES

Special attention should be paid to routing the UGATE, LGATE and PHASE traces since they drive the power train MOSFETs using short, high current pulses. It is important to size them as large and as short as possible to reduce their overall impedance and inductance. They should be sized to carry at least one ampere of current (0.02" to 0.05"). Going between layers with vias should also be avoided, however, if so, use two vias for interconnection when possible.

Extra care should be given to the LGATE traces in particular since keeping their impedance and inductance low helps to significantly reduce the possibility of shoot-through. It is also important to route each channels UGATE and PHASE traces in as close proximity as possible to reduce their inductances.

## CURRENT SENSE COMPONENT PLACEMENT AND TRACE ROUTING

One of the most critical aspects of the ISL8120 regulator layout is the placement of the inductor DCR current sense components and traces. The R-C current sense components must be placed as close to their respective ISENA and ISENB pins on the ISL8120 as possible.

The sense traces that connect the R-C sense components to each side of the output inductors should be routed away from the noisy switching components. These traces should be routed side by side, and they should be very thin traces. It is important to route these traces as far away from any other noisy traces or planes as possible. These traces should pick up as little noise as possible. These traces should also originate from the geometric center of the inductor pin pads and that location should be the single point of contact the trace makes with its respective net.

## GENERAL POWERPAD DESIGN CONSIDERATIONS

The following is an example of how to use vias to remove heat from the IC.

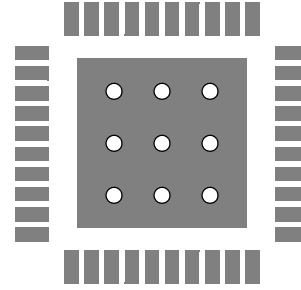

FIGURE 48. PCB VIA PATTERN

It is recommended to fill the thermal pad area with vias. A typical via array fills the thermal pad foot print such that their centers are 3x the radius apart from each other. Keep the vias small, however, not so small that their inside diameter prevents solder wicking through during reflow.

Connect all vias to the ground plane. It is important the vias have a low thermal resistance for efficient heat transfer. It is important to have a complete connection of the plated-through hole to each plane.

© Copyright Intersil Americas LLC 2008-2016. All Rights Reserved.  
All trademarks and registered trademarks are the property of their respective owners.

For additional products, see [www.intersil.com/en/products.html](http://www.intersil.com/en/products.html)

Intersil products are manufactured, assembled and tested utilizing ISO9001 quality systems as noted in the quality certifications found at [www.intersil.com/en/support/qualandreliability.html](http://www.intersil.com/en/support/qualandreliability.html)

*Intersil products are sold by description only. Intersil may modify the circuit design and/or specifications of products at any time without notice, provided that such modification does not, in Intersil's sole judgment, affect the form, fit or function of the product. Accordingly, the reader is cautioned to verify that datasheets are current before placing orders. Information furnished by Intersil is believed to be accurate and reliable. However, no responsibility is assumed by Intersil or its subsidiaries for its use; nor for any infringements of patents or other rights of third parties which may result from its use. No license is granted by implication or otherwise under any patent or patent rights of Intersil or its subsidiaries.*

For information regarding Intersil Corporation and its products, see [www.intersil.com](http://www.intersil.com)

**Revision History** The revision history provided is for informational purposes only and is believed to be accurate, but not warranted. Please go to the web to make sure that you have the latest revision.

DATE	REVISION	CHANGE
July 20, 2016	FN6641.3	Applied Intersil Standards throughout datasheet. Updated Related Literature section. Updated Note 1. Added Note 2. Added Units to Rising PVCC Threshold on page 16 and PLL Locking Time on page 16. Updated Column header of Table 1(second column) from EN1/FF1 to EN1/VFF1. Corrected typo on page 25 changed OV to OV. Added Revision History and About Intersil sections.

## About Intersil

Intersil Corporation is a leading provider of innovative power management and precision analog solutions. The company's products address some of the largest markets within the industrial and infrastructure, mobile computing and high-end consumer markets.

For the most updated datasheet, application notes, related documentation and related parts, please see the respective product information page found at [www.intersil.com](http://www.intersil.com).

You may report errors or suggestions for improving this datasheet by visiting [www.intersil.com/ask](http://www.intersil.com/ask).

Reliability reports are also available from our website at [www.intersil.com/support](http://www.intersil.com/support).

# Package Outline Drawing

## L32.5x5B

32 LEAD QUAD FLAT NO-LEAD PLASTIC PACKAGE

Rev 3, 5/10

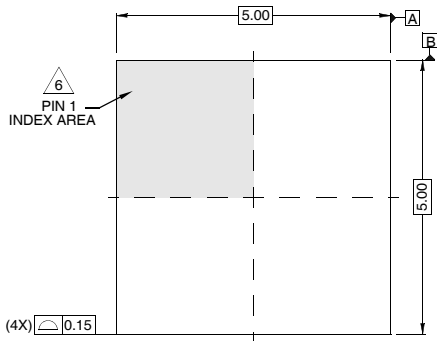

TOP VIEW

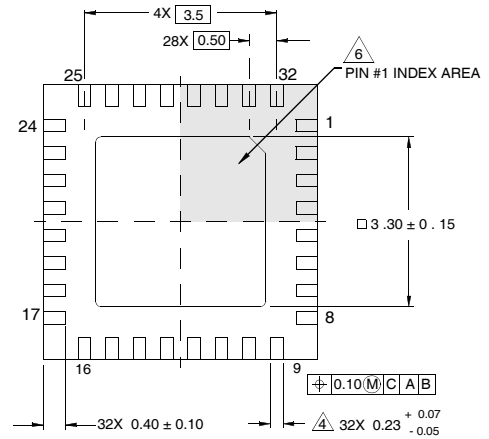

BOTTOM VIEW

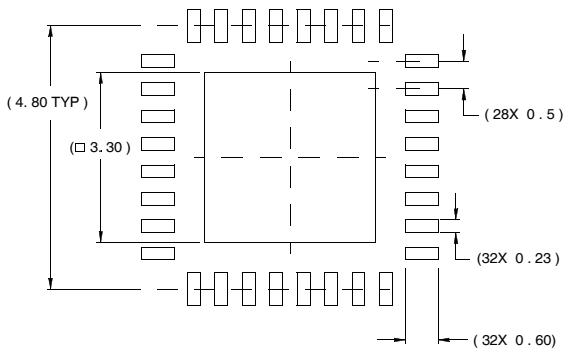

TYPICAL RECOMMENDED LAND PATTERN

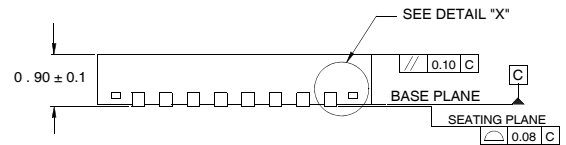

SIDE VIEW

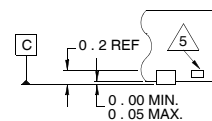

DETAIL "X"

NOTES:

1. Dimensions are in millimeters.  
Dimensions in ( ) for Reference Only.
2. Dimensioning and tolerancing conform to AMSE Y14.5m-1994.
3. Unless otherwise specified, tolerance : Decimal ± 0.05
- ④ Dimension applies to the metallized terminal and is measured between 0.15mm and 0.30mm from the terminal tip.
- ⑤ Tiebar shown (if present) is a non-functional feature.
- ⑥ The configuration of the pin #1 identifier is optional, but must be located within the zone indicated. The pin #1 identifier may be either a mold or mark feature.

## Looking for pricing, stock, or lifecycle information?

Click below to explore more details on WIN SOURCE:

 [View ISL8120CRZ-T on WIN SOURCE](#)

 [Intersil Information](#)

## Optimize Your Supply Chain with WIN SOURCE Solutions

-  Global Sourcing Solution
-  Obsolete Management
-  Cost Control Management
-  Shortage Management
-  Alternative Solution
-  Excess Inventory Management