



**THE DATASHEET OF
ISL84714IHZ-T**



ISL84714

Ultra Low ON-Resistance, Low Voltage, Single Supply, SPDT Analog Switch

FN6086
Rev 3.00
January 19, 2009

The Intersil ISL84714 device is a low ON-resistance, low voltage, bidirectional, single pole/double throw (SPDT) analog switch designed to operate from a single +1.65V to +3.6V supply. Targeted applications include battery powered equipment that benefit from low ON-resistance and fast switching speeds ($t_{ON} = 7.5\text{ns}$, $t_{OFF} = 2.9\text{ns}$). The digital logic input is 1.8V CMOS compatible when using a single +3V supply.

Cell phones, for example, often face ASIC functionality limitations. The number of analog input or GPIO pins may be limited and digital geometries are not well suited to analog switch performance. This part may be used to “mux-in” additional functionality while reducing ASIC design risk. The ISL84714 is offered in the 6 Ld SC70 package, alleviating board space limitations.

The ISL84714 is a committed SPDT that consists of one normally open (NO) and one normally closed (NC) switch. This configuration can also be used as a 2-to-1 multiplexer.

TABLE 1. FEATURES AT A GLANCE

ISL84714	
Number of Switches	1
SW	SPDT or 2-1 MUX
1.8V r_{ON}	0.75 Ω
1.8V t_{ON}/t_{OFF}	15.6ns/4.5ns
3V r_{ON}	0.38 Ω
3V t_{ON}/t_{OFF}	7.5ns/2.9ns
Package	6 Ld SC70

Features

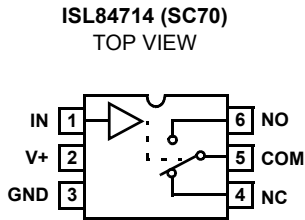
- Pb-Free Available (RoHS Compliant)
- Drop In Replacement for the MAX4714
- ON-resistance (r_{ON})
 - $V_{CC} = +2.7V$ 0.44 Ω
 - $V_{CC} = +1.8V$ 0.75 Ω
- r_{ON} Matching Between Channels 0.005 Ω
- r_{ON} Flatness (+2.7V Supply) 0.06 Ω
- Single Supply Operation. +1.65V to +3.6V
- Fast Switching Action (+2.7V Supply)
 - t_{ON} 7.5ns
 - t_{OFF} 2.9ns
- Guaranteed Break-Before-Make
- ESD HBM rating >6kV
- 1.8V, CMOS Logic Compatible (+3V supply)
- Available in 6 LD SC70 package

Applications

- Battery Powered, Handheld, and Portable Equipment
 - Cellular/Mobile Phones
 - Pagers
 - Laptops, Notebooks, Palmtops
- Portable Test and Measurement
- Medical Equipment
- Audio and Video Switching

Related Literature

- Technical Brief TB363 “Guidelines for Handling and Processing Moisture Sensitive Surface Mount Devices (SMDs)”

Pinout (Note)

Note: Switches Shown for Logic "0" Input.

Truth Table

LOGIC	PIN NC	PIN NUMBER
0	On	Off
1	Off	On

Note: Logic "0" $\leq 0.5V$. Logic "1" $\geq 1.4V$ with a 3V supply.

Pin Descriptions

PIN	FUNCTION
V+	System Power Supply Input (+1.65V to +3.6V)
GND	Ground Connection
IN	Digital Control Input
COM	Analog Switch Common Pin
NO	Analog Switch Normally Open Pin
NC	Analog Switch Normally Closed Pin

Ordering Information

PART NUMBER (Note)	PART MARKING	TEMP. RANGE (°C)	PACKAGE	PKG. DWG. NO.
ISL84714IH-T*	CAA	-40 to +85	6 Ld SC70 Tape and Reel	P6.049
ISL84714IHZ-T*	CDA	-40 to +85	6 Ld SC70 Tape and Reel (Pb-free)	P6.049

*Please refer to TB347 for details on reel specifications

NOTE: These Intersil Pb-Free plastic packaged products employ special Pb-Free material sets, molding compounds/die attach materials, and 100% matte tin plate plus anneal (e3 termination finish, which is RoHS compliant and compatible with both SnPb and Pb-Free soldering operations). Intersil Pb-Free products are MSL classified at Pb-Free peak reflow temperatures that meet or exceed the Pb-Free requirements of IPC/JEDEC J STD-020..

Absolute Maximum Ratings

V+ to GND	-0.3V to 4.8V
Input Voltages	
NO, NC, IN (Note 1)	-0.3 to ((V+) + 0.3V)
Output Voltages	
COM (Note 1)	-0.3 to ((V+) + 0.3V)
Continuous Current NO, NC, or COM	±150mA
Peak Current NO, NC, or COM	
(Pulsed 1ms, 10% Duty Cycle, Max)	±300mA
ESD Rating:	
HBM	>6kV
MM	>300V
CDM	>1000V

Thermal Information

Thermal Resistance (Typical, Note 2)	θ_{JA} (°C/W)
6 Ld SC70 Package	590
Maximum Junction Temperature (Plastic Package)	+150°C
Maximum Storage Temperature Range	-65°C to +150°C
Pb-Free Reflow Profile	see link below http://www.intersil.com/pbfree/Pb-FreeReflow.asp

Operating Conditions

Temperature Range	
ISL84714IH	-40°C to +85°C

CAUTION: Do not operate at or near the maximum ratings listed for extended periods of time. Exposure to such conditions may adversely impact product reliability and result in failures not covered by warranty.

NOTES:

- Signals on NC, NO, IN, or COM exceeding V+ or GND are clamped by internal diodes. Limit forward diode current to maximum current ratings.
- θ_{JA} is measured with the component mounted on a high effective thermal conductivity test board in free air. See Tech Brief TB379 for details.

Electrical Specifications - 3V Supply

Test Conditions: V+ = +2.7V to +3.6V, GND = 0V, V_{INH} = 1.4V, V_{INL} = 0.5V (Note 3), Unless Otherwise Specified.

PARAMETER	TEST CONDITIONS	TEMP (°C)	MIN (Note 7)	TYP	MAX (Note 7)	UNITS
ANALOG SWITCH CHARACTERISTICS						
Analog Signal Range, V _{ANALOG}		Full	0	-	V+	V
ON Resistance, r _{ON}	V+ = 2.7V, I _{COM} = 100mA, V _{NO} or V _{NC} = 1.5V (See Figure 5)	25	-	0.44	0.6	Ω
		Full	-	-	0.7	Ω
r _{ON} Matching Between Channels, Δr _{ON}	V+ = 2.7V, I _{COM} = 100mA, V _{NO} or V _{NC} = 1.5V	25	-	0.005	0.03	Ω
		Full	-	-	0.04	Ω
r _{ON} Flatness, R _{FLAT(ON)}	V+ = 2.7V, I _{COM} = 100mA, V _{NO} or V _{NC} = 0.6V, 1.5V, 2.1V (Note 5)	25	-	0.06	0.1	Ω
		Full	-	-	0.12	Ω
NO or NC OFF Leakage Current, I _{NO(OFF)} or I _{NC(OFF)}	V+ = 3.3V, V _{COM} = 0.3V, 3V, V _{NO} or V _{NC} = 3V, 0.3V	25	-2	-	2	nA
		Full	-10	-	10	nA
COM ON Leakage Current, I _{COM(ON)}	V+ = 3.3V, V _{COM} = 0.3V, 3V, or V _{NO} or V _{NC} = 0.3V, 3V, or Floating	25	-2	-	2	nA
		Full	-20	-	20	nA
DYNAMIC CHARACTERISTICS						
Turn-ON Time, t _{ON}	V+ = 2.7V, V _{NO} or V _{NC} = 1.5V, R _L = 50Ω, C _L = 35pF (See Figure 1, Note 6)	25	-	7.5	11	ns
		Full	-	-	13	ns
Turn-OFF Time, t _{OFF}	V+ = 2.7V, V _{NO} or V _{NC} = 1.5V, R _L = 50Ω, C _L = 35pF (See Figure 1, Note 6)	25	-	2.9	7	ns
		Full	-	-	9	ns
Break-Before-Make Time Delay, t _D	V+ = 3.0V, V _{NO} or V _{NC} = 1.5V, R _L = 50Ω, C _L = 35pF (See Figure 3, Note 6)	Full	1	4	-	ns
Charge Injection, Q	V _G = V+/2, R _G = 0Ω, C _L = 1.0nF (See Figure 2)	25	-	20	-	pC
OFF Isolation	R _L = 50Ω, C _L = 5pF, f = 1MHz, V _{COM} = 1V _{RMS} (See Figure 4)	25	-	-50	-	dB
Crosstalk (Channel-to-Channel)	R _L = 50Ω, C _L = 5pF, f = 1MHz, V _{COM} = 1V _{RMS} (See Figure 6)	25	-	-50	-	dB
Total Harmonic Distortion	f = 20Hz to 20kHz, V _{COM} = 2V _{P-P} , R _L = 32Ω	25	-	0.006	-	%
NO or NC OFF Capacitance, C _{OFF}	f = 1MHz, V _{NO} or V _{NC} = V _{COM} = 0V (See Figure 7)	25	-	40	-	pF
COM ON Capacitance, C _{COM(ON)}	f = 1MHz, V _{NO} or V _{NC} = V _{COM} = 0V (See Figure 7)	25	-	100	-	pF
POWER SUPPLY CHARACTERISTICS						
Power Supply Range		Full	1.65	-	3.6	V

Electrical Specifications - 3V Supply

Test Conditions: $V_+ = +2.7V$ to $+3.6V$, $GND = 0V$, $V_{INH} = 1.4V$, $V_{INL} = 0.5V$ (Note 3),
Unless Otherwise Specified. **(Continued)**

PARAMETER	TEST CONDITIONS	TEMP (°C)	MIN (Note 7)	TYP	MAX (Note 7)	UNITS
Positive Supply Current, I_+	$V_+ = 3.6V$, $V_{IN} = 0V$ or V_+	25	-	0.018	0.05	μA
		Full	-	-	0.35	μA
DIGITAL INPUT CHARACTERISTICS						
Input Voltage Low, V_{INL}		Full	-	-	0.5	V
Input Voltage High, V_{INH}		Full	1.4	-	-	V
Input Current, I_{INH} , I_{INL}	$V_+ = 3.6V$, $V_{IN} = 0V$ or V_+ (Note 6)	Full	-1	-	1	μA

NOTES:

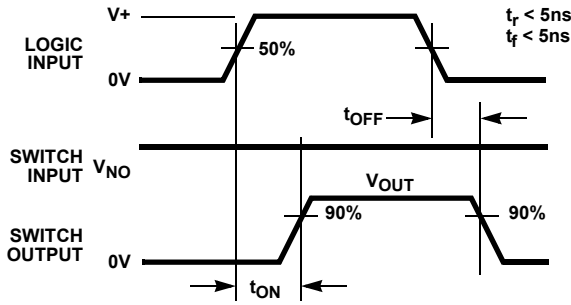
- V_{IN} = input voltage to perform proper function.
- The algebraic convention, whereby the most negative value is a minimum and the most positive a maximum, is used in this data sheet.
- Flatness is defined as the difference between maximum and minimum value of ON-resistance over the specified analog signal range.
- Limits should be considered typical and are not production tested.
- Parameters with MIN and/or MAX limits are 100% tested at $+25^\circ C$, unless otherwise specified. Temperature limits established by characterization and are not production tested.

Electrical Specifications - 1.8V Supply

Test Conditions: $V_+ = +1.8V$, $GND = 0V$, $V_{INH} = 1V$, $V_{INL} = 0.4V$ (Notes 3),
Unless Otherwise Specified.

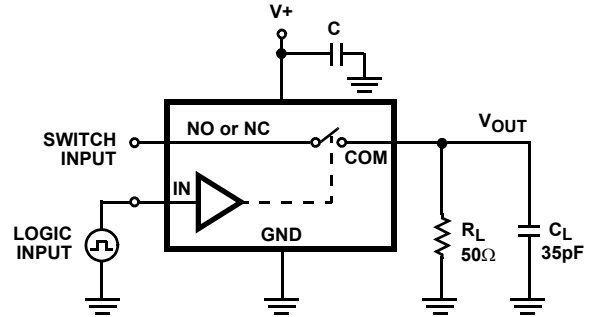
PARAMETER	TEST CONDITIONS	TEMP (°C)	MIN (Note 7)	TYP	MAX (Note 7)	UNITS
ANALOG SWITCH CHARACTERISTICS						
Analog Signal Range, V_{ANALOG}		Full	0	-	V_+	V
ON Resistance, r_{ON}	$V_+ = 1.8V$, $I_{COM} = 10mA$, V_{NO} or $V_{NC} = 0.9V$ (See Figure 5)	25	-	0.75	0.9	Ω
		Full	-	-	1	Ω
NO or NC OFF Leakage Current, $I_{NO(OFF)}$ or $I_{NC(OFF)}$	$V_+ = 1.8V$, $V_{COM} = 0.3V, 1.5V$, V_{NO} or $V_{NC} = 1.5V, 0.3V$	25	-2	-	2	nA
		Full	-10	-	10	nA
COM ON Leakage Current, $I_{COM(ON)}$	$V_+ = 1.8V$, $V_{COM} = 0.3V, 1.5V$, or V_{NO} or $V_{NC} = 0.3V, 1.5V$, or Floating	25	-2	-	2	nA
		Full	-20	-	20	nA
DYNAMIC CHARACTERISTICS						
Turn-ON Time, t_{ON}	$V_+ = 1.8V$, V_{NO} or $V_{NC} = 1.5V$, $R_L = 50\Omega$, $C_L = 35pF$ (See Figure 1, Note 6)	25	-	15.6	19	ns
		Full	-	-	21	ns
Turn-OFF Time, t_{OFF}	$V_+ = 1.8V$, V_{NO} or $V_{NC} = 1.5V$, $R_L = 50\Omega$, $C_L = 35pF$ (See Figure 1, Note 6)	25	-	4.5	9	ns
		Full	-	-	11	ns
Break-Before-Make Time Delay, t_D	$V_+ = 1.8V$, V_{NO} or $V_{NC} = 1.5V$, $R_L = 50\Omega$, $C_L = 35pF$ (See Figure 3, Note 6)	Full	2	5	-	ns
Charge Injection, Q	$V_G = V_+/2$, $R_G = 0\Omega$, $C_L = 1.0nF$ (See Figure 2)	25	-	15	-	pC
POWER SUPPLY CHARACTERISTICS						
Positive Supply Current, I_+	$V_{IN} = 0V$ or V_+	25	-	0.018	0.05	μA
		Full	-	-	0.35	μA
DIGITAL INPUT CHARACTERISTICS						
Input Voltage Low, V_{INL}		Full	-	-	0.4	V
Input Voltage High, V_{INH}		Full	1	-	-	V
Input Current, I_{INH} , I_{INL}	$V_{IN} = 0V$ or V_+	Full	-1	-	1	μA

Test Circuits and Waveforms



NOTE: LOGIC INPUT WAVEFORM IS INVERTED FOR SWITCHES THAT HAVE THE OPPOSITE LOGIC SENSE.

FIGURE 1A. MEASUREMENT POINTS



NOTE: REPEAT TEST FOR ALL SWITCHES. CL INCLUDES FIXTURE AND STRAY CAPACITANCE.

$$V_{OUT} = V_{(NO \text{ or } NC)} \frac{R_L}{R_L + r_{i(ON)}}$$

FIGURE 1B. TEST CIRCUIT

FIGURE 1. SWITCHING TIMES

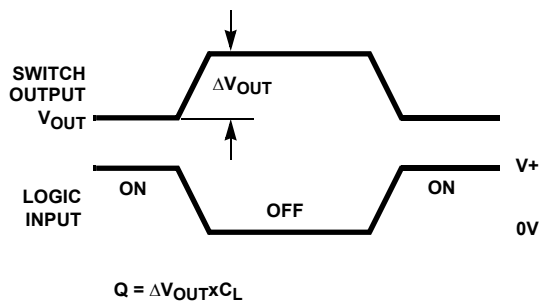


FIGURE 2A. MEASUREMENT POINTS



FIGURE 2B. TEST CIRCUIT

FIGURE 2. CHARGE INJECTION

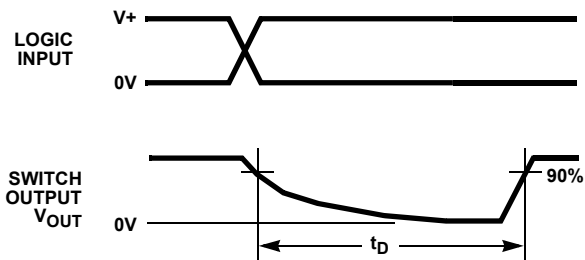
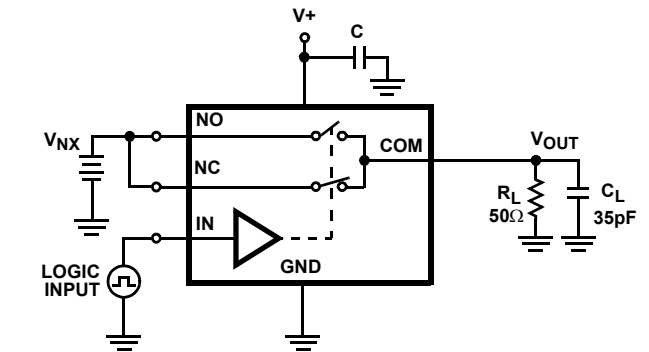


FIGURE 3A. MEASUREMENT POINTS



NOTE: CL INCLUDES FIXTURE AND STRAY CAPACITANCE.

FIGURE 3B. TEST CIRCUIT

FIGURE 3. BREAK-BEFORE-MAKE TIME

Test Circuits and Waveforms (Continued)

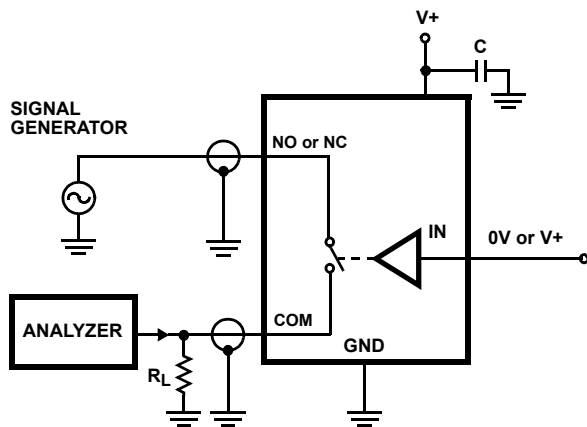


FIGURE 4. OFF ISOLATION TEST CIRCUIT

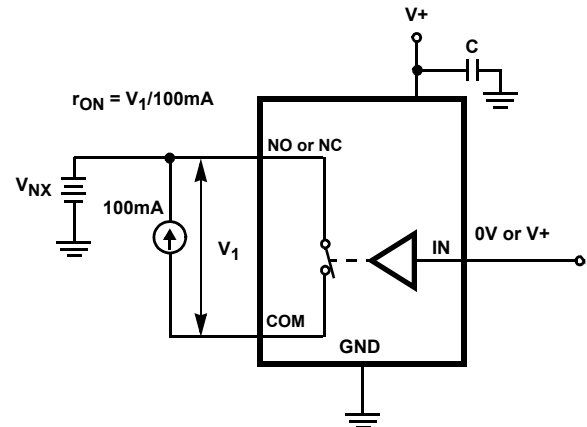
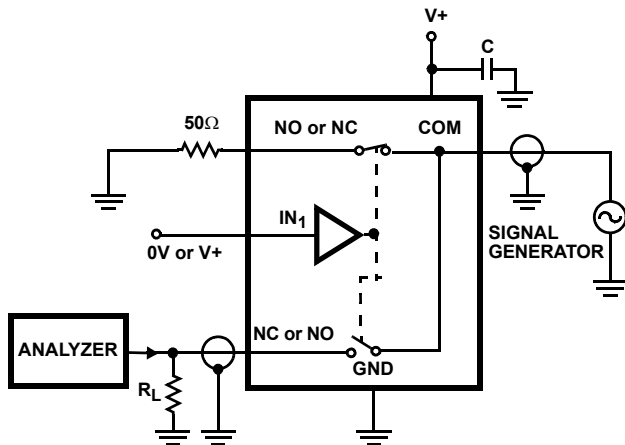
FIGURE 5. r_{ON} TEST CIRCUIT

FIGURE 6. CROSSTALK TEST CIRCUIT

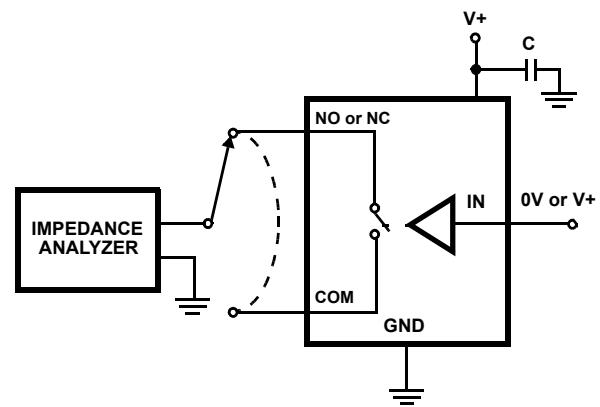


FIGURE 7. CAPACITANCE TEST CIRCUIT

Detailed Description

The ISL84714 is a bi-directional, single pole/double throw (SPDT) analog switch that offers precise switching capability from a single 1.65V to 3.6V supply with low ON-resistance (0.44Ω) and high speed operation ($t_{ON} = 7.5\text{ns}$, $t_{OFF} = 2.9\text{ns}$). The device is especially well suited for portable battery powered equipment due to its low operating supply voltage (1.65V), low power consumption ($1.05\mu\text{W}$), low leakage currents (20nA max), and the tiny SC70 packaging. The ultra low ON-resistance and r_{ON} flatness provide very low insertion loss and distortion to application that require signal reproduction.

Supply Sequencing And Overvoltage Protection

With any CMOS device, proper power supply sequencing is required to protect the device from excessive input currents which might permanently damage the IC. All I/O pins contain ESD protection diodes from the pin to V+ and to GND (See Figure 8). To prevent forward biasing these diodes, V+ must be applied before any input signals, and the input signal voltages must remain between V+ and GND. If these conditions cannot be guaranteed, then one of the following two protection methods should be employed.

Logic inputs can easily be protected by adding a 1k Ω resistor in series with the input (see Figure 8). The resistor limits the input current below the threshold that produces permanent damage, and the sub-microamp input current produces an insignificant voltage drop during normal operation.

This method is not acceptable for the signal path inputs. Adding a series resistor to the switch input defeats the purpose of using a low r_{ON} switch, so two small signal diodes can be added in series with the supply pins to provide overvoltage protection for all pins (see Figure 8). These additional diodes limit the analog signal from 1V below $V+$ to 1V above GND. The low leakage current performance is unaffected by this approach, but the switch signal range is reduced and the resistance may increase, especially at low supply voltages.

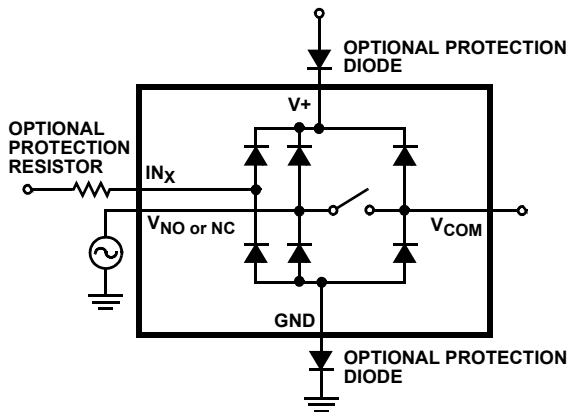


FIGURE 8. OVERVOLTAGE PROTECTION

Power-Supply Considerations

The ISL84714 construction is typical of most single supply CMOS analog switches, in that they have two supply pins: $V+$ and GND. $V+$ and GND drive the internal CMOS switches and set their analog voltage limits. Unlike switches with a 4V maximum supply voltage, the ISL84714 4.8V maximum supply voltage provides plenty of room for the 10% tolerance of 3.6V supplies, as well as room for overshoot and noise spikes.

The minimum recommended supply voltage is 1.65V but the part will operate with a supply below 1.5V. It is important to note that the input signal range, switching times, and ON-resistance degrade at lower supply voltages. Refer to the “Electrical Specifications” Table beginning on page 3 and “Typical Performance Curves” on page 8 for details.

$V+$ and GND also power the internal logic and level shifters. The level shifters convert the input logic levels to switched $V+$ and GND signals to drive the analog switch gate terminals.

This family of switches cannot be operated with bipolar supplies, because the input switching point becomes negative in this configuration.

Logic-Level Thresholds

This switch family is 1.8V CMOS compatible (0.5V and 1.4V) over a supply range of 2V to 3.6V (see Figure 15). At 3.6V the V_{IH} level is about 1.1V. This is still below the 1.8V CMOS guaranteed high output minimum level of 1.4V, but noise margin is reduced.

The digital input stages draw supply current whenever the digital input voltage is not at one of the supply rails. Driving the digital input signals from GND to $V+$ with a fast transition time minimizes power dissipation.

High-Frequency Performance

In 50 Ω systems, signal response is reasonably flat even past 90MHz (see Figure 16). The frequency response is very consistent over a wide $V+$ range, and for varying analog signal levels.

An OFF switch acts like a capacitor and passes higher frequencies with less attenuation, resulting in signal feedthrough from a switch’s input to its output. OFF Isolation is the resistance to this feedthrough, while crosstalk indicates the amount of feedthrough from one switch to another. Figure 17 details the high OFF Isolation and crosstalk rejection provided by this family. At 1MHz, Off Isolation is about 50dB in 50 Ω systems, decreasing approximately 20dB per decade as frequency increases. Higher load impedances decrease OFF Isolation and crosstalk rejection due to the voltage divider action of the switch OFF impedance and the load impedance.

Leakage Considerations

Reverse ESD protection diodes are internally connected between each analog-signal pin and both $V+$ and GND. One of these diodes conducts if any analog signal exceeds $V+$ or GND.

Virtually all the analog leakage current comes from the ESD diodes to $V+$ or GND. Although the ESD diodes on a given signal pin are identical and therefore fairly well balanced, they are reverse biased differently. Each is biased by either $V+$ or GND and the analog signal. This means their leakages will vary as the signal varies. The difference in the two diode leakages to the $V+$ and GND pins constitutes the analog-signal-path leakage current. All analog leakage current flows between each pin and one of the supply terminals, not to the other switch terminal. This is why both sides of a given switch can show leakage currents of the same or opposite polarity. There is no connection between the analog signal paths and $V+$ or GND.

Typical Performance Curves $T_A = +25^\circ\text{C}$, Unless Otherwise Specified

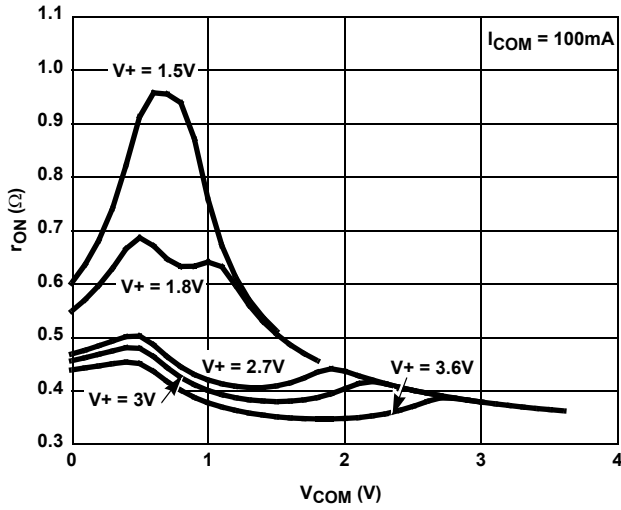


FIGURE 9. ON-RESISTANCE vs SUPPLY VOLTAGE vs SWITCH VOLTAGE

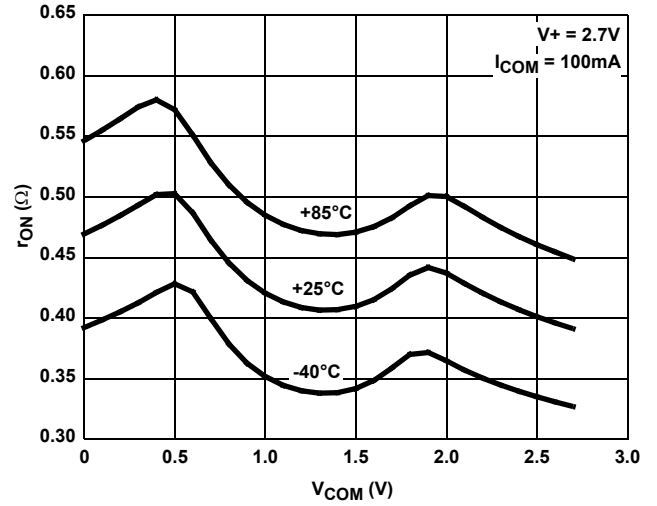


FIGURE 10. ON-RESISTANCE vs SWITCH VOLTAGE

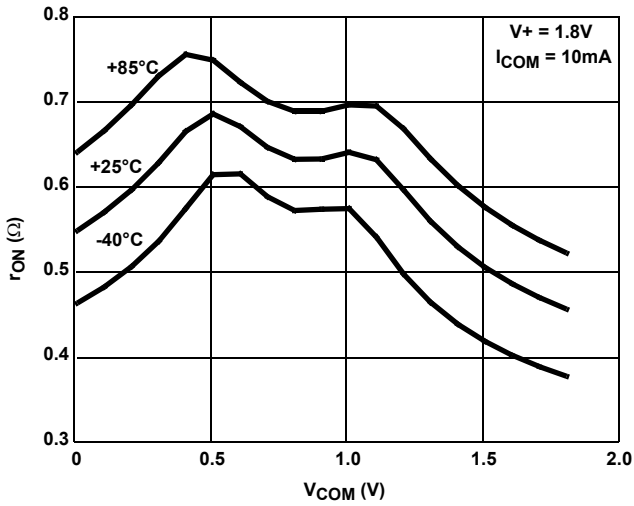


FIGURE 11. ON-RESISTANCE vs SWITCH VOLTAGE

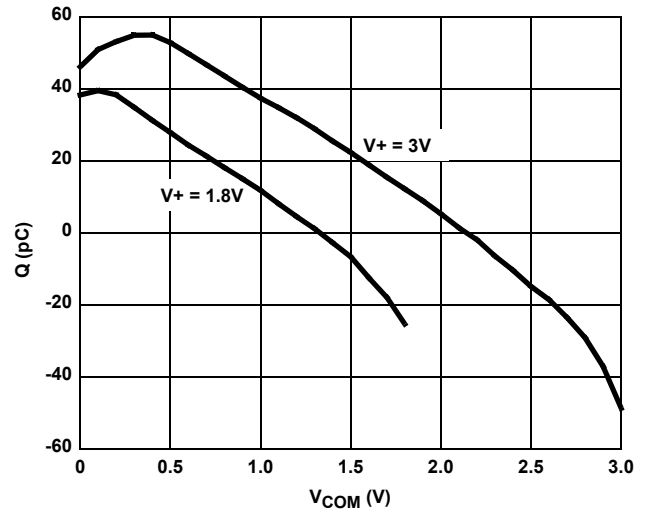


FIGURE 12. CHARGE INJECTION vs SWITCH VOLTAGE

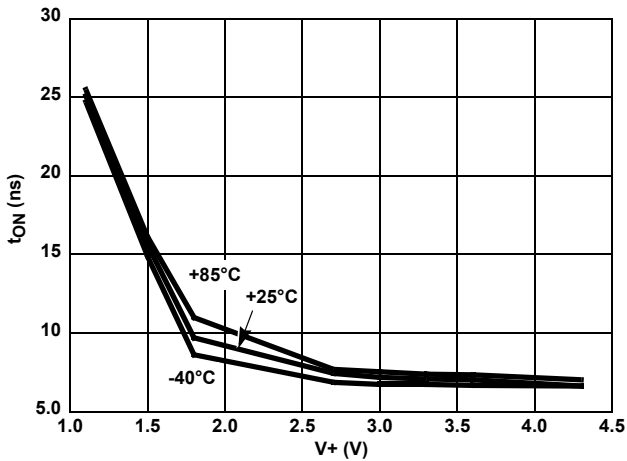


FIGURE 13. TURN-ON TIME vs SUPPLY VOLTAGE

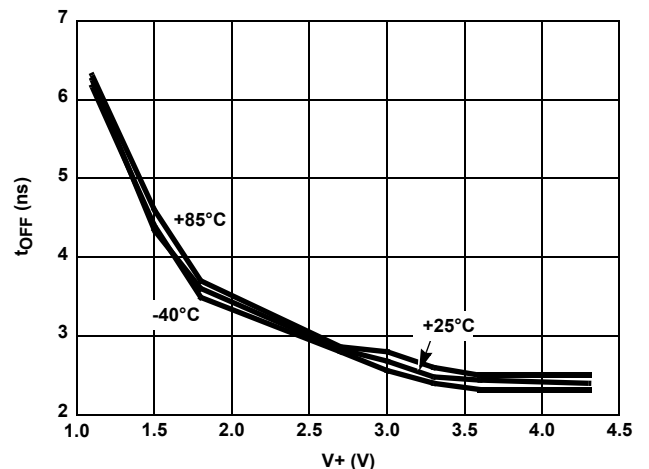


FIGURE 14. TURN-OFF TIME vs SUPPLY VOLTAGE

Typical Performance Curves $T_A = +25^\circ\text{C}$, Unless Otherwise Specified (Continued)

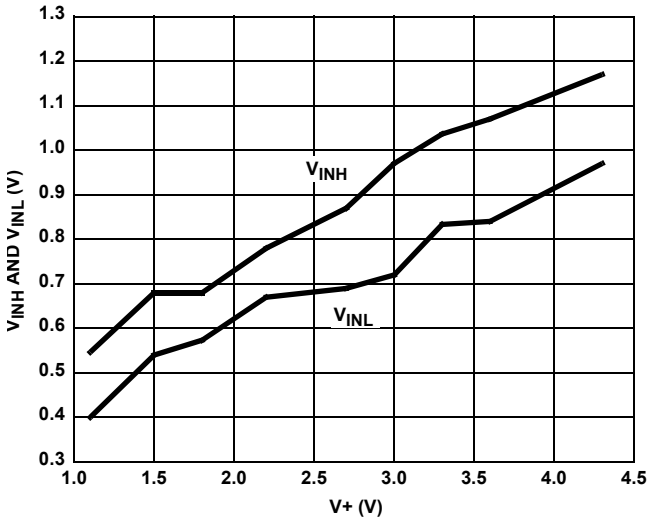


FIGURE 15. DIGITAL SWITCHING POINT vs SUPPLY VOLTAGE

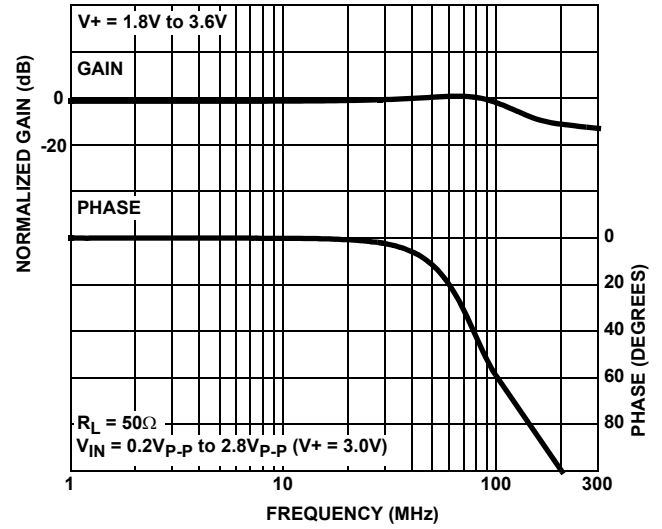


FIGURE 16. FREQUENCY RESPONSE

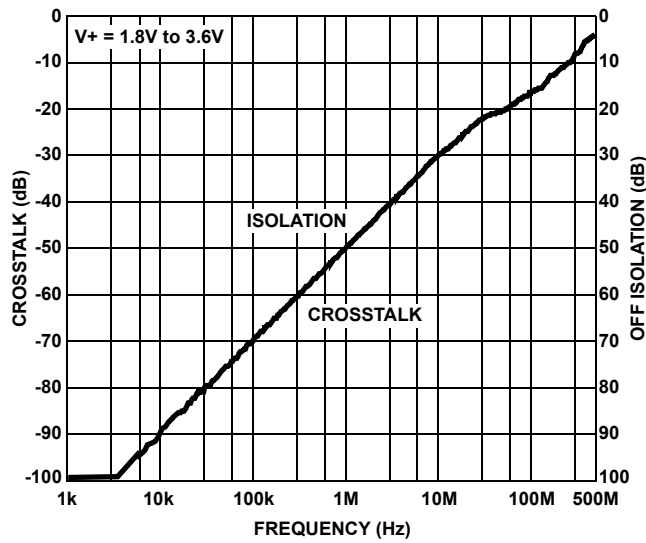


FIGURE 17. CROSSTALK AND OFF ISOLATION

Die Characteristics

SUBSTRATE POTENTIAL (POWERED UP):

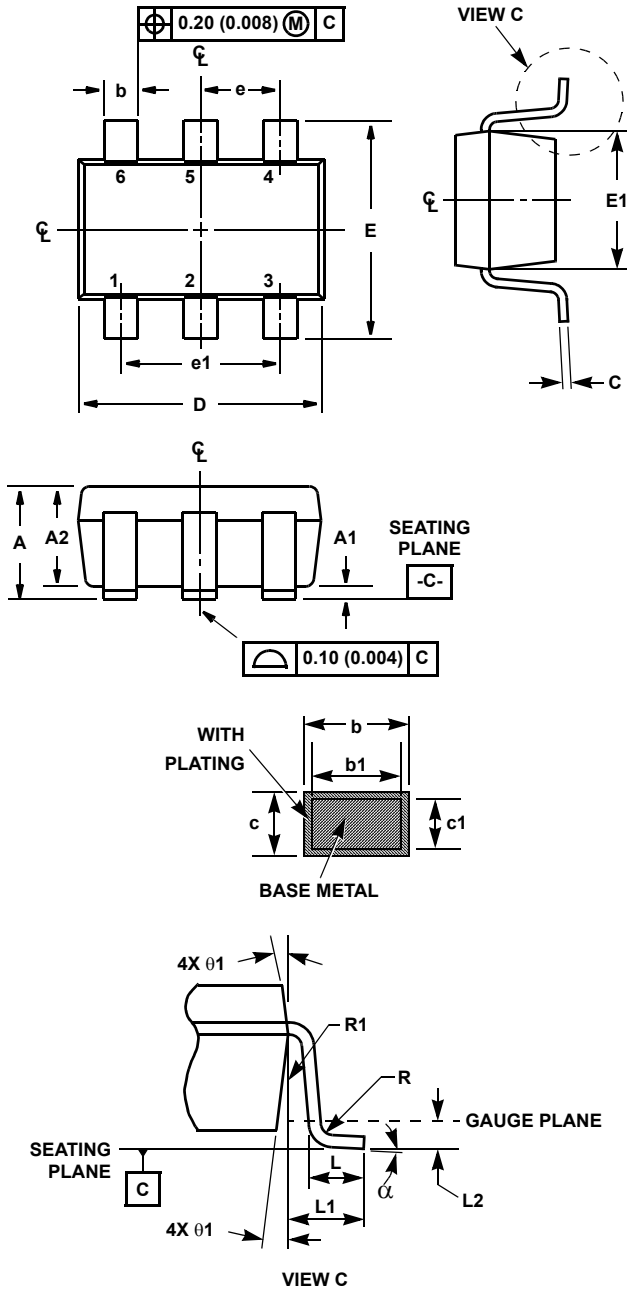
GND

TRANSISTOR COUNT: 57

PROCESS:

Submicron CMOS

Small Outline Transistor Plastic Packages (SC70-6)



P6.049

6 LEAD SMALL OUTLINE TRANSISTOR PLASTIC PACKAGE

SYMBOL	INCHES		MILLIMETERS		NOTES
	MIN	MAX	MIN	MAX	
A	0.031	0.043	0.80	1.10	-
A1	0.000	0.004	0.00	0.10	-
A2	0.031	0.039	0.00	1.00	-
b	0.006	0.012	0.15	0.30	-
b1	0.006	0.010	0.15	0.25	-
c	0.003	0.009	0.08	0.22	6
c1	0.003	0.009	0.08	0.20	6
D	0.073	0.085	1.85	2.15	3
E	0.071	0.094	1.80	2.40	-
E1	0.045	0.053	1.15	1.35	3
e	0.0256 Ref		0.65 Ref		-
e1	0.0512 Ref		1.30 Ref		-
L	0.010	0.018	0.26	0.46	4
L1	0.017 Ref.		0.420 Ref.		-
L2	0.006 BSC		0.15 BSC		-
N	6		6		5
R	0.004	-	0.10	-	-
R1	0.004	0.010	0.15	0.25	-
alpha	0°	8°	0°	8°	-

Rev. 2 9/03

NOTES:

1. Dimensioning and tolerance per ASME Y14.5M-1994.
2. Package conforms to EIAJ SC70 and JEDEC MO203AB.
3. Dimensions D and E1 are exclusive of mold flash, protrusions, or gate burrs.
4. Footlength L measured at reference to gauge plane.
5. "N" is the number of terminal positions.
6. These Dimensions apply to the flat section of the lead between 0.08mm and 0.15mm from the lead tip.
7. Controlling dimension: MILLIMETER. Converted inch dimensions are for reference only

© Copyright Intersil Americas LLC 2004-2009. All Rights Reserved.
 All trademarks and registered trademarks are the property of their respective owners.

For additional products, see www.intersil.com/en/products.html

Intersil products are manufactured, assembled and tested utilizing ISO9001 quality systems as noted in the quality certifications found at www.intersil.com/en/support/qualandreliability.html

Intersil products are sold by description only. Intersil may modify the circuit design and/or specifications of products at any time without notice, provided that such modification does not, in Intersil's sole judgment, affect the form, fit or function of the product. Accordingly, the reader is cautioned to verify that datasheets are current before placing orders. Information furnished by Intersil is believed to be accurate and reliable. However, no responsibility is assumed by Intersil or its subsidiaries for its use; nor for any infringements of patents or other rights of third parties which may result from its use. No license is granted by implication or otherwise under any patent or patent rights of Intersil or its subsidiaries.

For information regarding Intersil Corporation and its products, see www.intersil.com

Looking for pricing, stock, or lifecycle information?

Click below to explore more details on WIN SOURCE:

 [View ISL84714IHZ-T on WIN SOURCE](#)

 [Intersil Information](#)

Optimize Your Supply Chain with WIN SOURCE Solutions

-  Global Sourcing Solution
-  Obsolete Management
-  Cost Control Management
-  Shortage Management
-  Alternative Solution
-  Excess Inventory Management