



## ISL97645A

Boost + V<sub>ON</sub> Slice + V<sub>COM</sub> + Reset

FN6353  
Rev 1.00  
October 21, 2010

The ISL97645A represents an integrated DC/DC regulator for monitor and notebook applications with screen sizes up to 20". The device integrates a boost converter for generating A<sub>VDD</sub>, a V<sub>ON</sub> slice circuit, and a high performance V<sub>COM</sub> amplifier.

The boost converter features a 2.6A FET and has user programmable soft-start and compensation. With efficiencies up to 92%, the A<sub>VDD</sub> is user selectable from 7V to 20V.

The V<sub>ON</sub> slice circuit can control gate voltages up to 30V. High and low levels are programmable, as well as discharge rate and timing.

The supply monitor can be used to monitor the input voltage to prevent low voltage operation.

The integrated V<sub>COM</sub> features high speed and drive capability. With 30MHz bandwidth and 50V/μs slew rate, the V<sub>COM</sub> amplifier is capable of driving 400mA peaks, and 100mA continuous output current.

### Ordering Information

PART NUMBER (Notes 1, 2, 3)	PART MARKING	TEMP. RANGE (°C)	PACKAGE (Pb-Free)	PKG. DWG. #
ISL97645AIRZ	976 45AIRZ	-40 to +85	24 Ld 4x4 QFN	L24.4x4D

#### NOTES:

1. Add "-T\*" suffix for tape and reel. Please refer to [TB347](#) for details on reel specifications.
2. These Intersil Pb-free plastic packaged products employ special Pb-free material sets, molding compounds/die attach materials, and 100% matte tin plate plus anneal (e3 termination finish, which is RoHS compliant and compatible with both SnPb and Pb-free soldering operations). Intersil Pb-free products are MSL classified at Pb-free peak reflow temperatures that meet or exceed the Pb-free requirements of IPC/JEDEC J STD-020.
3. For Moisture Sensitivity Level (MSL), please see device information page for [ISL97645A](#). For more information on MSL please see techbrief [TB363](#).

### Features

- 2.7V to 5.5V Input
- 2.6A Integrated Boost for Up to 20V A<sub>VDD</sub>
- Integrated V<sub>ON</sub> Slice
- RESET signal generated by Supply Monitor
- 600kHz/1.2MHz f<sub>S</sub>
- V<sub>COM</sub> Amplifier
  - 30MHz BW
  - 50V/μs SR
  - 400mA Peak Output Current
- UV and OT Protection
- 24 Ld 4x4 QFN
- Pb-Free (RoHS Compliant)

### Applications

- LCD Monitors (15"+)
- Notebook Display (up to 16")

### Pinout

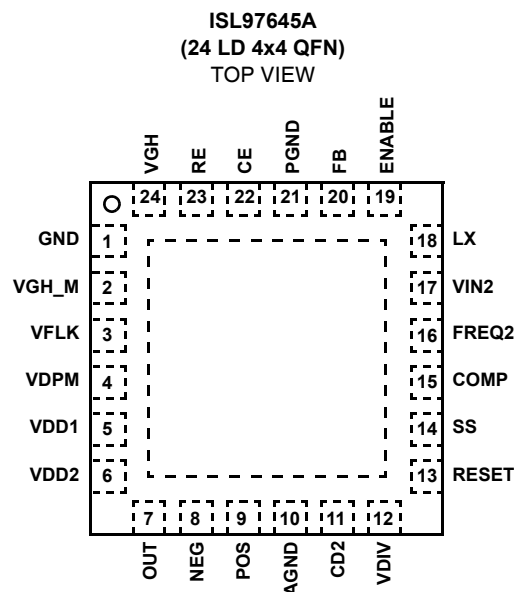

## Pin Descriptions

PIN NUMBER	NAME	DESCRIPTION
1	GND	Signal ground
2	VGH_M	Gate Pulse Modulator Output
3	VFLK	Gate Pulse Modulator Control input
4	VDPM	Gate Pulse Modulator Enable. Connect a capacitor from VDPM to GND to set the delay time before GPM is enabled. A 20 $\mu$ A current source charges CDPM. Power on delay time = 60.75k*CDPM.
5	VDD1	Gate Pulse Modulator Low Voltage Input
6	VDD2	VCOM Amplifier Supply
7	OUT	VCOM Amplifier Output
8	NEG	VCOM Amplifier Inverting input
9	POS	VCOM Amplifier Non-inverting input
10	AGND	VCOM Amplifier Ground
11	CD2	Voltage detector rising edge delay. Connect a capacitor between this pin and GND to set the rising edge delay.
12	VDIV	Voltage detector threshold. Connect to the center of a resistive divider between V <sub>IN</sub> and GND.
13	RESET	Voltage detector reset output.
14	SS	Boost Converter Soft-Start. Connect a capacitor between this pin and GND to set the soft-start time.
15	COMP	Boost Converter Compensation pin. Connect a series resistor and capacitor between this pin and GND to optimize transient response.
16	FREQ	Boost Converter frequency select
17	VIN2	Boost Converter power supply
18	LX	Boost Converter Switching Node
19	ENABLE	Chip Enable pin. Connect to VIN1 for normal operation, GND for shutdown.
20	FB	Boost Converter Feedback
21	PGND	Boost Converter Power Ground
22	RE	Gate Pulse Modulator Slew Control. Connect a resistor between this pin and GND to set the falling slew rate.
23	CE	Gate Pulse Modulator Delay Control. Connect a capacitor between this pin and GND to set the delay time.
24	VGH	Gate Pulse Modulator High Voltage Input

**Absolute Maximum Ratings**

Lx to GND, AGND and PGND	-0.5 to +25V
VDD2, OUT, NEG and POS	
to GND, AGND and PGND	-0.5 to +25V
VDD1, VGH and VGH_M	
to GND, AGND and PGND	-0.5 to +32V
Differential Voltage Between POS and NEG	±6V
Voltage Between GND, AGND and PGND	±0.5V
All Other Pins to GND, AGND and PGND	-0.5 to +6.5V
Input, Output, or I/O Voltage	GND -0.3V to VIN + 0.3V

**Recommended Operating Conditions**

Input Voltage Range, VS	2.7V to 5.5V
Boost Output Voltage Range, AVDD	8V to 20V
Input Capacitance, CIN	22µF
Boost Inductor, L1	3.3µH to 10µH
Output Capacitance, COUT	2µF x 22µF
Operating Ambient Temperature Range	-40°C to +85°C
Operating Junction Temperature	-40°C to +125°C

**CAUTION:** Do not operate at or near the maximum ratings listed for extended periods of time. Exposure to such conditions may adversely impact product reliability and result in failures not covered by warranty.

**NOTES:**

4.  $\theta_{JA}$  is measured in free air with the component mounted on a high effective thermal conductivity test board with "direct attach" features. See Tech Brief TB379.
5. For  $\theta_{JC}$ , the "case temp" location is the center of the exposed metal pad on the package underside.

**Electrical Specifications**  $V_{IN} = \text{ENABLE} = 5V$ ,  $V_{DD1} = V_{DD2} = 14V$ ,  $V_{GH} = 25V$ ,  $AV_{DD} = 10V$ ,  $T_A = -40^\circ\text{C}$  to  $+85^\circ\text{C}$   
Unless Otherwise Noted. **Boldface limits apply over the operating temperature range, -40°C to +85°C.**

SYMBOL	PARAMETER	TEST CONDITION	MIN (Note 6)	TYP	MAX (Note 6)	UNIT
<b>GENERAL</b>						
$V_S$	$V_{IN}$ Input Voltage Range		<b>2.7</b>	3.3	<b>5.5</b>	V
$I_{S\_DIS}$	$V_{IN}$ Supply Currents when Disabled	ENABLE = 0V		1	<b>3.5</b>	µA
$I_S$	$V_{IN}$ Supply Currents	ENABLE = 5V, LX not switching		1		mA
UVLO	Under Voltage Lockout Threshold	$V_{IN2}$ Rising	<b>2.3</b>	2.45	<b>2.6</b>	V
		$V_{IN2}$ Falling	<b>2.2</b>	2.35	<b>2.5</b>	V
$OT_R$	Thermal Shutdown Temperature	Temperature Rising		140		°C
$OT_F$		Temperature Falling		100		°C
<b>LOGIC INPUT CHARACTERISTICS - ENABLE, VFLK, FREQ, VDPM</b>						
$V_{IL}$	Low Voltage Threshold				<b>0.8</b>	V
$V_{IH}$	High Voltage Threshold		<b>2.2</b>			V
$R_{IL}$	Pull-Down Resistor	Enabled, Input at $V_{IN}$	<b>150</b>	250	<b>400</b>	kΩ
<b>STEP-UP SWITCHING REGULATOR</b>						
$AV_{DD}$	Output Voltage Range		$V_{IN} * 1.25$		<b>20</b>	V
$\Delta V_{BOOST}/\Delta I_{OUT}$	Load Regulation	$50\text{mA} < I_{LOAD} < 250\text{mA}$		0.2		%
$\Delta V_{BOOST}/\Delta V_{IN}$	Line Regulation	$I_{LOAD} = 150\text{mA}$ , $3.0 < V_{IN} < 5.5V$		0.15	<b>0.25</b>	%
$ACC_{AV_{DD}}$	Overall Accuracy (Line, Load, Temperature)	$10\text{mA} < I_{LOAD} < 300\text{mA}$ , $3.0 < V_{IN} < 5.5V$ , $0^\circ\text{C} < T_A < +85^\circ\text{C}$	<b>-3</b>		<b>3</b>	%
$V_{FB}$	Feedback Voltage ( $V_{FB}$ )	$I_{LOAD} = 100\text{mA}$ , $T_A = +25^\circ\text{C}$	1.20	1.21	1.22	V
		$I_{LOAD} = 100\text{mA}$ , $T_A = -40^\circ\text{C}$ to $+85^\circ\text{C}$	<b>1.19</b>	1.21	<b>1.23</b>	V

**Thermal Information**

Thermal Resistance	$\theta_{JA}$ (°C/W)	$\theta_{JC}$ (°C/W)
4x4 QFN Package (Notes 4, 5)	39	2.5
Storage Temperature	-65°C to +150°C	
Maximum Continuous Junction Temperature	+125°C	
Power Dissipation		
$T_A \leq +25^\circ\text{C}$	2.44W	
$T_A = +70^\circ\text{C}$	1.34W	
$T_A = +85^\circ\text{C}$	0.98W	
$T_A = +100^\circ\text{C}$	0.61W	
Pb-Free Reflow Profile	see link below	
	<a href="http://www.intersil.com/pbfree/Pb-FreeReflow.asp">http://www.intersil.com/pbfree/Pb-FreeReflow.asp</a>	

**Electrical Specifications**  $V_{IN} = \text{ENABLE} = 5\text{V}$ ,  $V_{DD1} = V_{DD2} = 14\text{V}$ ,  $V_{GH} = 25\text{V}$ ,  $AV_{DD} = 10\text{V}$ ,  $T_A = -40^\circ\text{C}$  to  $+85^\circ\text{C}$   
 Unless Otherwise Noted. **Boldface limits apply over the operating temperature range,  $-40^\circ\text{C}$  to  $+85^\circ\text{C}$ . (Continued)**

SYMBOL	PARAMETER	TEST CONDITION	MIN (Note 6)	TYP	MAX (Note 6)	UNIT
$I_{FB}$	FB Input Bias Current			250	<b>500</b>	nA
$r_{DS(ON)}$	Switch ON-resistance			150	<b>300</b>	$m\Omega$
EFF	Peak Efficiency			92		%
$I_{LIM}$	Switch Current Limit			2.9		A
$D_{MAX}$	Max Duty Cycle		<b>85</b>	90		%
$f_{OSC}$	Oscillator Frequency	FREQ = 0V	<b>550</b>	650	<b>800</b>	kHz
		FREQ = $V_{IN2}$	<b>1.0</b>	1.2	<b>1.4</b>	MHz
$I_{SS}$	Soft-Start Slew Current	SS < 1V, $T_A = +25^\circ\text{C}$		2.75		$\mu\text{A}$
<b>V<sub>COM</sub> AMPLIFIER</b> $R_{LOAD} = 10\text{k}$ , $C_{LOAD} = 10\text{pF}$ , Unless Otherwise Stated						
$V_{SAMP}$	Supply Voltage		<b>4.5</b>		<b>20</b>	V
$I_{SAMP}$	Supply Current			3		mA
$V_{OS}$	Offset Voltage			3	<b>20</b>	mV
$I_B$	Noninverting Input Bias Current			0	<b>100</b>	nA
CMIR	Common Mode Input Voltage Range		<b>0</b>		<b>VDD2</b>	V
CMRR	Common-Mode Rejection Ratio		<b>50</b>	70		dB
PSRR	Power Supply Rejection Ratio		<b>70</b>	85		dB
$V_{OH}$	Output Voltage Swing High	$I_{OUT}(\text{source}) = 5\text{mA}$		VDD2 - 50		mV
$V_{OH}$	Output Voltage Swing High	$I_{OUT}(\text{source}) = 50\text{mA}$		VDD2 - 450		mV
$V_{OL}$	Output Voltage Swing Low	$I_{OUT}(\text{sink}) = 5\text{mA}$		50		mV
$V_{OL}$	Output Voltage Swing Low	$I_{OUT}(\text{sink}) = 50\text{mA}$		450		mV
$I_{SC}$	Output Short Circuit Current		<b>250</b>	400		mA
SR	Slew Rate			50		V/ $\mu\text{s}$
BW	Gain Bandwidth	-3dB gain point		30		MHz
<b>GATE PULSE MODULATOR</b>						
$V_{GH}$	VGH Voltage		<b>7</b>		<b>30</b>	V
$V_{IH\_VDPM}$	VDPM Enable Threshold		<b>1.18</b>	1.215	<b>1.25</b>	V
$I_{VGH}$	VGH Input Current	VFLK = 0		260		$\mu\text{A}$
		RE = 33k $\Omega$ , VFLK = VDD1		40		$\mu\text{A}$
$V_{DD1}$	VDD1 Voltage		<b>3</b>		<b>VGH - 2</b>	V
$I_{VDD1}$	VDD1 Input Current		<b>-2</b>	0.1	<b>2</b>	$\mu\text{A}$
$R_{ONVGH}$	VGH to VGH_M On Resistance			70		$\Omega$
$I_{DIS\_VGH}$	VGH_M Discharge Current	RE = 33k $\Omega$		8		mA
IDPM	VDPM Charge Current			20		$\mu\text{A}$
$t_{DEL}$	DELAY Time	CE = 470pF, RE = 33k $\Omega$		1.9		$\mu\text{s}$

**Electrical Specifications**  $V_{IN} = \text{ENABLE} = 5V$ ,  $V_{DD1} = V_{DD2} = 14V$ ,  $V_{GH} = 25V$ ,  $A_{VDD} = 10V$ ,  $T_A = -40^{\circ}C$  to  $+85^{\circ}C$   
 Unless Otherwise Noted. **Boldface limits apply over the operating temperature range,  $-40^{\circ}C$  to  $+85^{\circ}C$ .** (Continued)

SYMBOL	PARAMETER	TEST CONDITION	MIN (Note 6)	TYP	MAX (Note 6)	UNIT
<b>SUPPLY MONITOR</b>						
$V_{IH\_VDIV}$	VDIV High Threshold	VDIV rising	<b>1.18</b>			V
$V_{IL\_VDIV}$	VDIV Low Threshold	VDIV falling			<b>1.05</b>	V
$I_{CD2}$	CD2 Charge Current			10		$\mu A$
$R_{IL\_RESET}$	RESET Pull-Down Resistance			750		$\Omega$
$t_{DELAY\_RESET}$	RESET Delay on the Rising Edge			121.5k*CD		s

NOTE:

- 6. Parameters with MIN and/or MAX limits are 100% tested at  $+25^{\circ}C$ , unless otherwise specified. Temperature limits established by characterization and are not production tested.

**Typical Performance Curves**

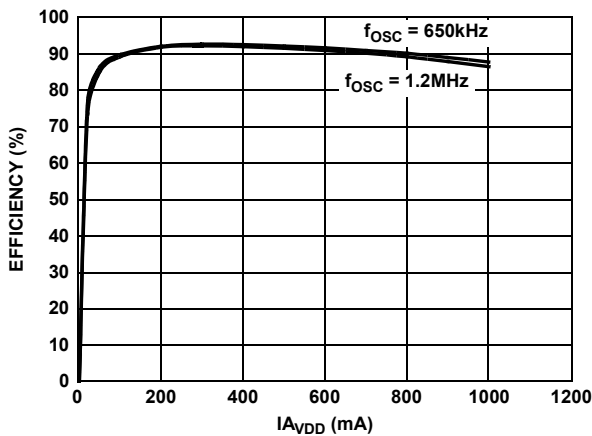

FIGURE 1.  $A_{VDD}$  EFFICIENCY vs  $I_{A_{VDD}}$

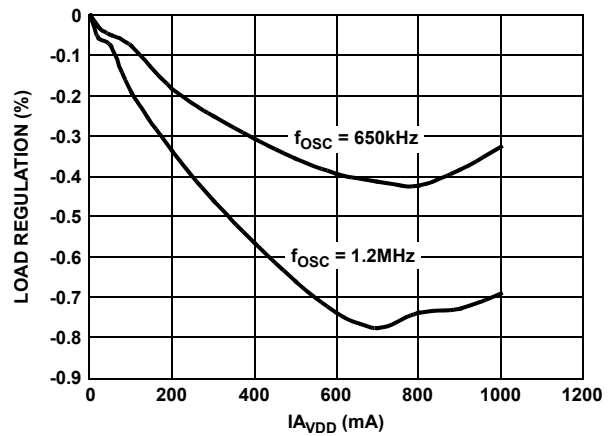

FIGURE 2.  $A_{VDD}$  LOAD REGULATION vs  $I_{A_{VDD}}$

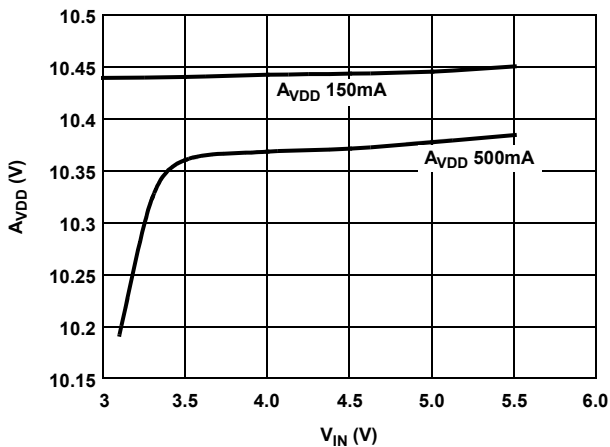

FIGURE 3. LINE REGULATION  $A_{VDD}$  vs  $V_{IN}$

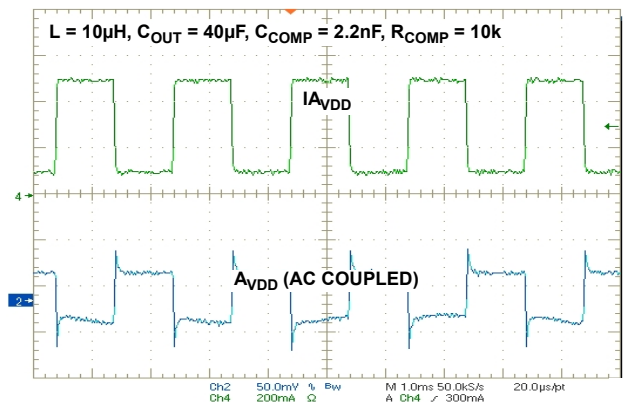

FIGURE 4. BOOST CONVERTER TRANSIENT RESPONSE

Typical Performance Curves (Continued)

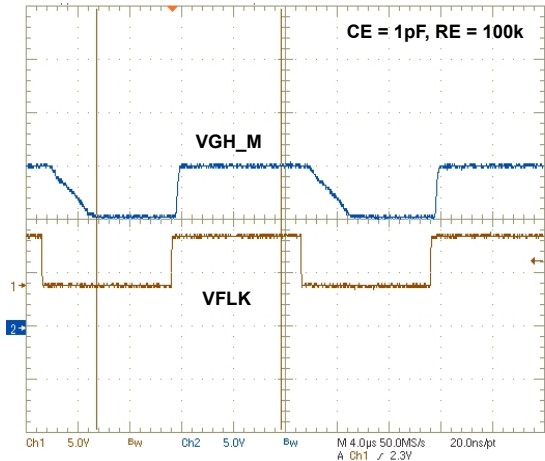

FIGURE 5. GPM CIRCUIT WAVEFORM

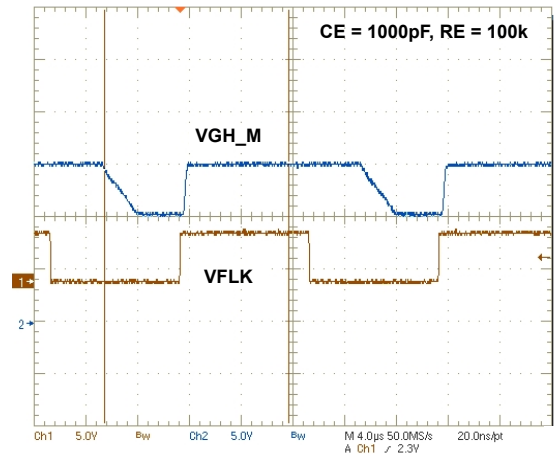

FIGURE 6. GPM CIRCUIT WAVEFORM

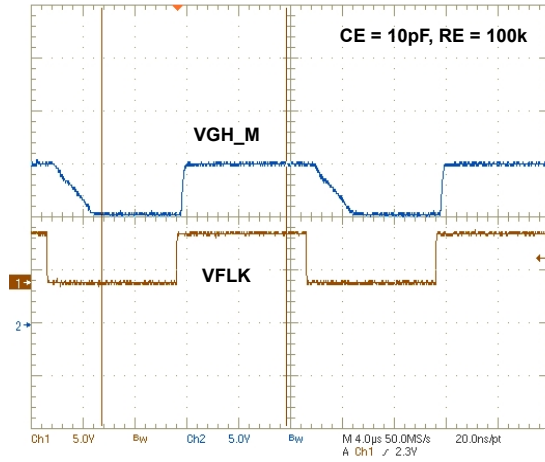

FIGURE 7. GPM CIRCUIT WAVEFORM

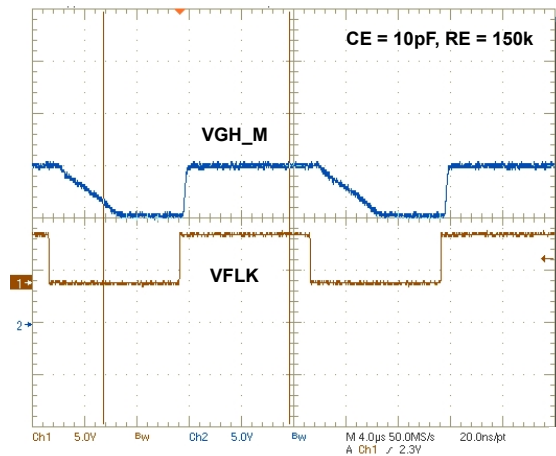

FIGURE 8. GPM CIRCUIT WAVEFORM

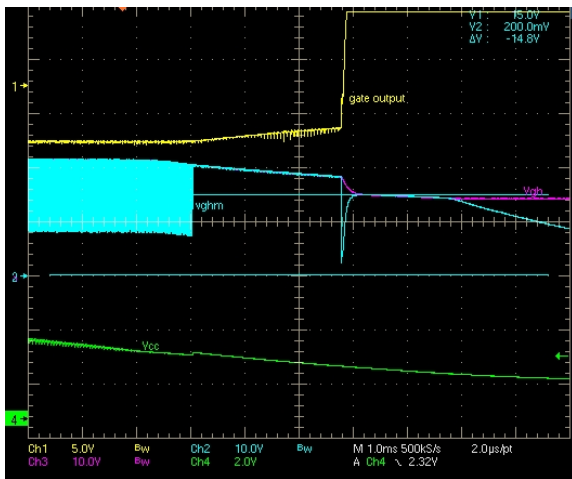

FIGURE 9.  $V_{GHM}$  FOLLOWS  $V_{GH}$  WHEN THE SYSTEM POWERS OFF

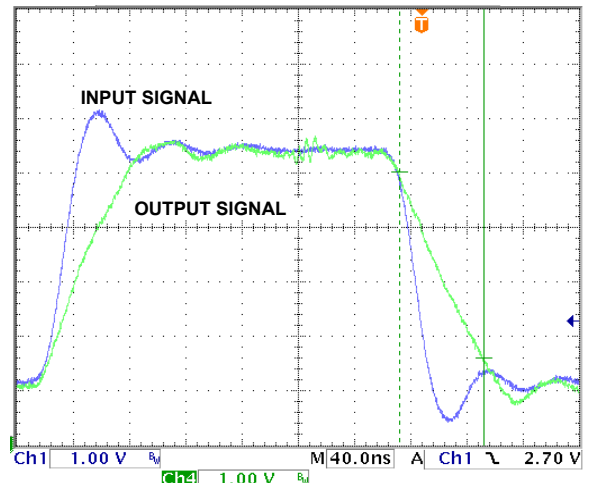

FIGURE 10.  $V_{COM}$  RISING SLEW RATE

Typical Performance Curves (Continued)

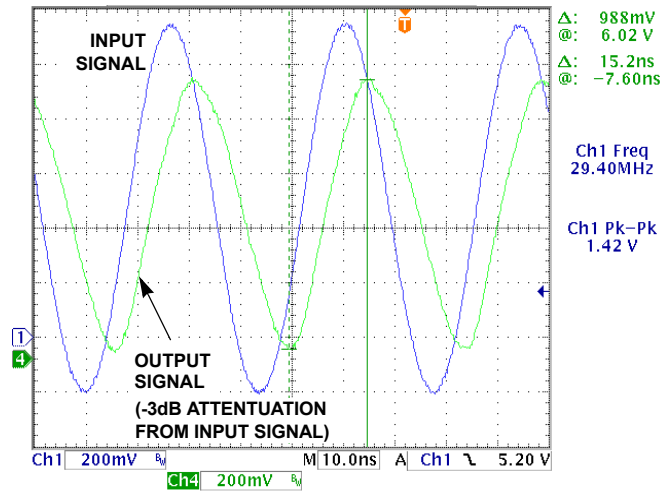

FIGURE 11.  $V_{COM}$  BANDWIDTH MEASUREMENT

**Block Diagram**

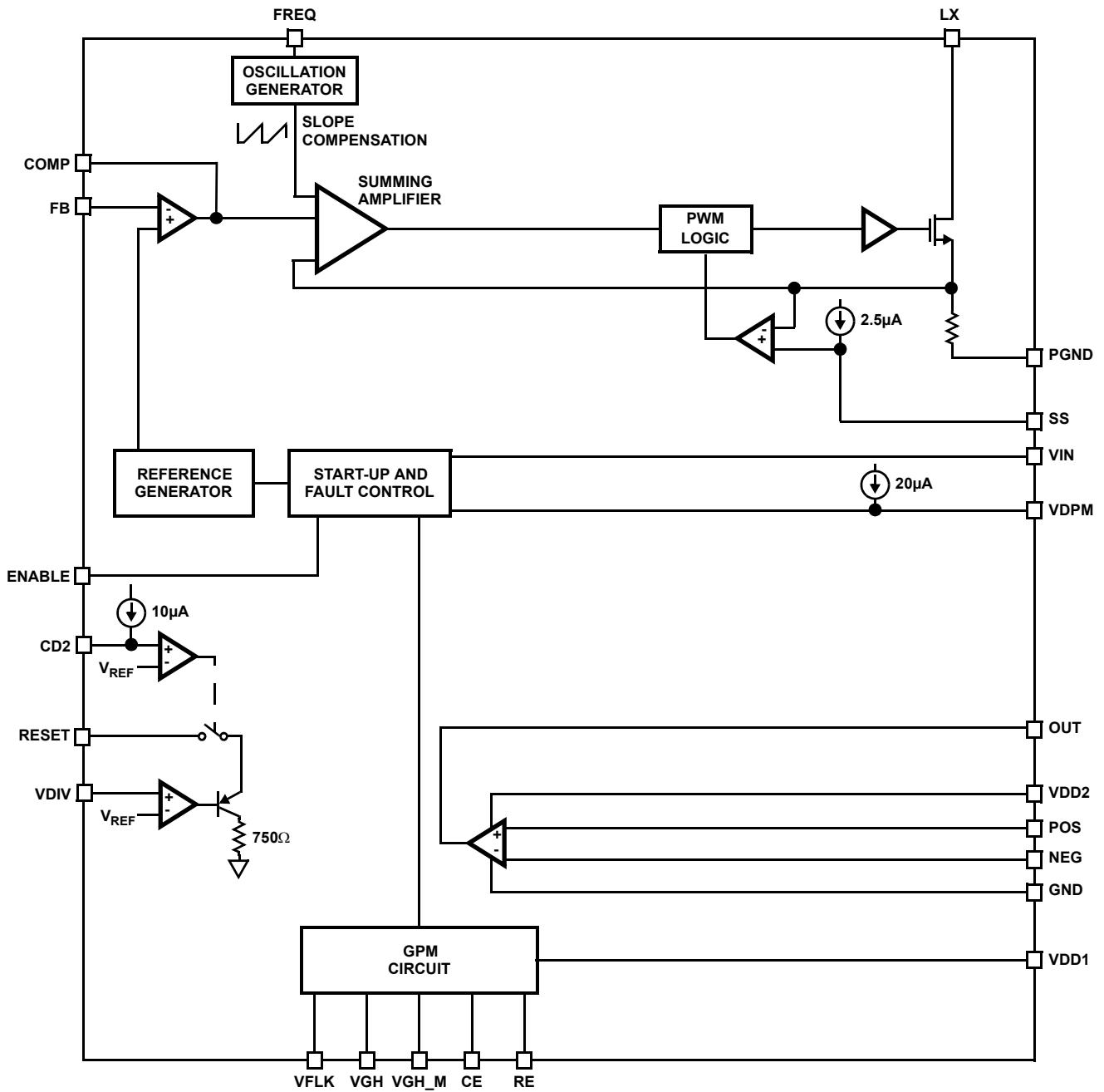

FIGURE 12. ISL97645A BLOCK DIAGRAM



## Operation

The boost converter is a current mode PWM converter operating at either a 650kHz or 1.2MHz. It can operate in both discontinuous conduction mode (DCM) at light load and continuous mode (CCM). In continuous current mode, current flows continuously in the inductor during the entire switching cycle in steady state operation. The voltage conversion ratio in continuous current mode is given by Equation 1:

$$\frac{V_{\text{Boost}}}{V_{\text{IN}}} = \frac{1}{1-D} \quad (\text{EQ. 1})$$

Where D is the duty cycle of the switching MOSFET.

Figure 12 shows the block diagram of the boost regulator. It uses a summing amplifier architecture consisting of gm stages for voltage feedback, current feedback and slope compensation. A comparator looks at the peak inductor current cycle by cycle and terminates the PWM cycle if the current limit is reached.

An external resistor divider is required to divide the output voltage down to the nominal reference voltage. Current drawn by the resistor network should be limited to maintain the overall converter efficiency. The maximum value of the resistor network is limited by the feedback input bias current and the potential for noise being coupled into the feedback pin. A resistor network in the order of 60kΩ is recommended. The boost converter output voltage is determined by Equation 2:

$$V_{\text{Boost}} = \frac{R_1 + R_2}{R_2} \times V_{\text{FB}} \quad (\text{EQ. 2})$$

The current through the MOSFET is limited to  $2.6A_{\text{PEAK}}$ .

This restricts the maximum output current (average) based on Equation 3:

$$I_{\text{OMAX}} = \left( I_{\text{LMT}} - \frac{\Delta I_L}{2} \right) \times \frac{V_{\text{IN}}}{V_{\text{O}}} \quad (\text{EQ. 3})$$

Where  $\Delta I_L$  is peak to peak inductor ripple current, and is set by Equation 4:

$$\Delta I_L = \frac{V_{\text{IN}}}{L} \times \frac{D}{f_s} \quad (\text{EQ. 4})$$

where  $f_s$  is the switching frequency (650kHz or 1.2MHz).

Table 2 gives typical values (margins are considered 10%, 3%, 20%, 10% and 15% on  $V_{\text{IN}}$ ,  $V_{\text{O}}$ , L,  $f_s$  and  $I_{\text{OMAX}}$ ).

## Capacitor

An input capacitor is used to suppress the voltage ripple injected into the boost converter. The ceramic capacitor with capacitance larger than 10μF is recommended. The voltage rating of input capacitor should be larger than the maximum input voltage. Some capacitors are recommended in Table 1 for input capacitor.

**TABLE 1. BOOST CONVERTER INPUT CAPACITOR RECOMMENDATION**

CAPACITOR	SIZE	MFG	PART NUMBER
10μF/16V	1206	TDK	C3216X7R1C106M
10μF/10V	0805	Murata	GRM21BR61A106K
22μF/10V	1210	Murata	GRB32ER61A226K

**TABLE 2. MAXIMUM OUTPUT CURRENT CALCULATION**

$V_{\text{IN}}$ (V)	$V_{\text{O}}$ (V)	L (μH)	$f_s$ (MHz)	$I_{\text{OMAX}}$ (mA)
3	9	10	0.65	636
3	12	10	0.65	419
3	15	10	0.65	289
5	9	10	0.65	1060
5	12	10	0.65	699
5	15	10	0.65	482
5	18	10	0.65	338
3	9	10	1.2	742
3	12	10	1.2	525
3	15	10	1.2	395
5	9	10	1.2	1236
5	12	10	1.2	875
5	15	10	1.2	658
5	18	10	1.2	514

### Inductor

The boost inductor is a critical part which influences the output voltage ripple, transient response, and efficiency. Values of 3.3μH to 10μH are used to match the internal slope compensation. The inductor must be able to handle the following average and peak current are in Equation 5:

$$I_{LAVG} = \frac{I_O}{1-D} \quad (\text{EQ. 5})$$

$$I_{LPK} = I_{LAVG} + \frac{\Delta I_L}{2}$$

Some inductors are recommended in Table 3.

**TABLE 3. BOOST INDUCTOR RECOMMENDATION**

INDUCTOR	DIMENSIONS (mm)	MFG	PART NUMBER
6.8μH/3A <sub>PEAK</sub>	7.3x6.8x3.2	TDK	RLF7030T-6R8N3R0
10μH/4A <sub>PEAK</sub>	8.3x8.3x4.5	Sumida	CDR8D43-100NC
5.2μH/4.55A <sub>PEAK</sub>	10x10.1x3.8	Cooper Bussmann	CD1-5R2

### Rectifier Diode

A high-speed diode is necessary due to the high switching frequency. Schottky diodes are recommended because of their fast recovery time and low forward voltage. The reverse voltage rating of this diode should be higher than the maximum output voltage. The rectifier diode must meet the output current and peak inductor current requirements. The following table is some recommendations for boost converter diode.

**TABLE 4. BOOST CONVERTER RECTIFIER DIODE RECOMMENDATION**

DIODE	V <sub>R</sub> /I <sub>AVG</sub> RATING	PACKAGE	MFG
SS23	30V/2A	SMB	Fairchild Semiconductor
MBRS340	40V/3A	SMC	International Rectifier
SL23	30V/2A	SMB	Vishay Semiconductor

### Output Capacitor

The output capacitor supplies the load directly and reduces the ripple voltage at the output. Output ripple voltage consists of two components:

1. the voltage drop due to the inductor ripple current flowing through the ESR of output capacitor.
2. charging and discharging of the output capacitor.

$$V_{RIPPLE} = I_{LPK} \times ESR + \frac{V_O - V_{IN}}{V_O} \times \frac{I_O}{C_{OUT}} \times \frac{1}{f_s} \quad (\text{EQ. 6})$$

For low ESR ceramic capacitors, the output ripple is dominated by the charging and discharging of the output capacitor. The voltage rating of the output capacitor should be greater than the maximum output voltage.

Note: Capacitors have a voltage coefficient that makes their effective capacitance drop as the voltage across them increases. C<sub>OUT</sub> in the equation above assumes the effective value of the capacitor at a particular voltage and not the manufacturer's stated value, measured at 0V.

Table 5 shows some selections of output capacitors.

**TABLE 5. BOOST OUTPUT CAPACITOR RECOMMENDATION**

CAPACITOR	SIZE	MFG	PART NUMBER
10μF/25V	1210	TDK	C3225X7R1E106M
10μF/25V	1210	Murata	GRM32DR61E106K

### Compensation

The boost converter of ISL97645A can be compensated by a RC network connected from CM1 pin to ground. 4.7nF and 10k RC network is used in the demo board. The larger value resistor and lower value capacitor can lower the transient overshoot, however, at the expense of stability of the loop.

### Cascaded MOSFET Application

An 20V N-Channel MOSFET is integrated in the boost regulator. For the applications where the output voltage is greater than 20V, an external cascaded MOSFET is needed as shown in Figure 14. The voltage rating of the external MOSFET should be greater than A<sub>VDD</sub>.

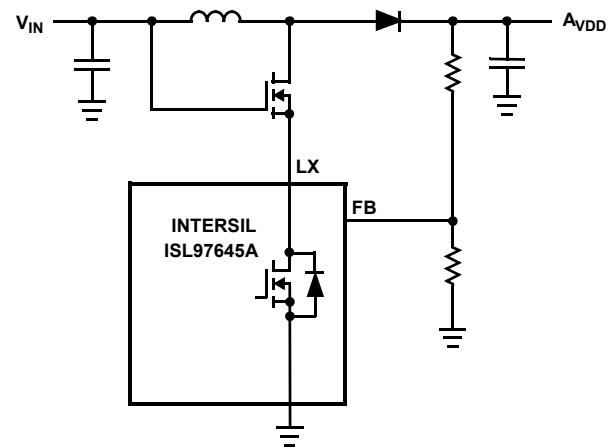

**FIGURE 14. CASCADED MOSFET TOPOLOGY FOR HIGH OUTPUT VOLTAGE APPLICATIONS**

## Supply Monitor Circuit

The Supply Monitor circuit monitors the voltage on VDIV, and sets open-drain output RESET low when VDIV is below 1.15V (rising) or 1.1V (falling).

There is a delay on the rising edge, controlled by a capacitor on CD2. When VDIV exceeds 1.15V (rising), CD2 is charged up from 0V to 1.215V by a 10 $\mu$ A current source. Once CD2 exceeds 1.215V, RESET will go tri-state. When VDIV falls below 1.1V, RESET will become low with a 750 pull-down resistance. The delay time is controlled by Equation 7:

$$t_{\text{delay}} = 121.5k \times CD2 \quad (\text{EQ. 7})$$

For example, the delay time is 12.15ms if the CD2 = 100nF.

Figure 15 is the Supply Monitor Circuit timing diagram.

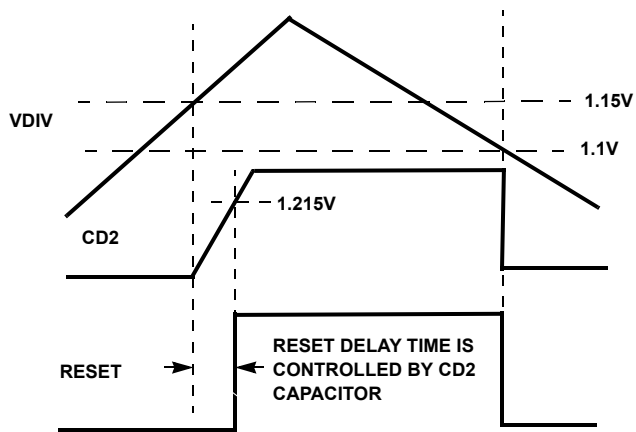

FIGURE 15. SUPPLY MONITOR CIRCUIT TIMING DIAGRAM

## Gate Pulse Modulator Circuit

The gate pulse modulator circuit functions as a three way multiplexer, switching VGHM between ground, VDD1 and VGH. Voltage selection is provided by digital inputs VDPM (enable) and VFLK (control). High to low delay and slew control is provided by external components on pins CE and RE, respectively. A block diagram of the gate pulse modulator circuit is shown in Figure 16.

When VDPM is LOW, the block is disabled and VGHM is grounded. When the input voltage exceeds UVLO threshold, VDPM starts to drive an external capacitor with 20 $\mu$ A. Once VDPM exceeds 1.215V, the GPM circuit is enabled, and the output VGH\_M is determined by VFLK, RESET signal and VGH voltage. If RESET signal is high, and when VFLK goes high, VGHM is pulled to VGH by a 70 $\Omega$  switch. When VFLK goes low, there is a delay controlled by capacitor CE, following which VGHM is driven to VDD1, with a slew rate controlled by resistor RE. Note that VDD1 is used only as a reference voltage for an amplifier, thus does not have to source or sink a significant DC current.

Low to high transition is determined primarily by the switch resistance and the external capacitive load. High to low transition is more complex. Take the case where the block is already enabled (VDPM is H). When VFLK is H, pin CE is grounded. On the falling edge of VFLK, a current is passed into pin CE, to charge an external capacitor to 1.2V. This creates a delay, equal to  $CE \cdot 4200$ . At this point, the output begins to pull down from VGH to VDD1. The slew current is equal to  $300 / (RE + 5000)$ , and the  $dv/dt$  slew rate is  $Isl / C_{LOAD}$ .

where  $C_{LOAD}$  is the load capacitance applied to VGHM.

When RESET signal changes to low, and VGH voltage is above 2.5V, the VGH\_M will be tied to VGH voltage until the VGH voltage falls down to 2.5V. If the VGH voltage is lower than 2.5V, GPM block will not work properly, and there is no active control for VGH\_M output. The following table shows the VGH\_M status based on  $V_{IN}$ , VGH and RESET:

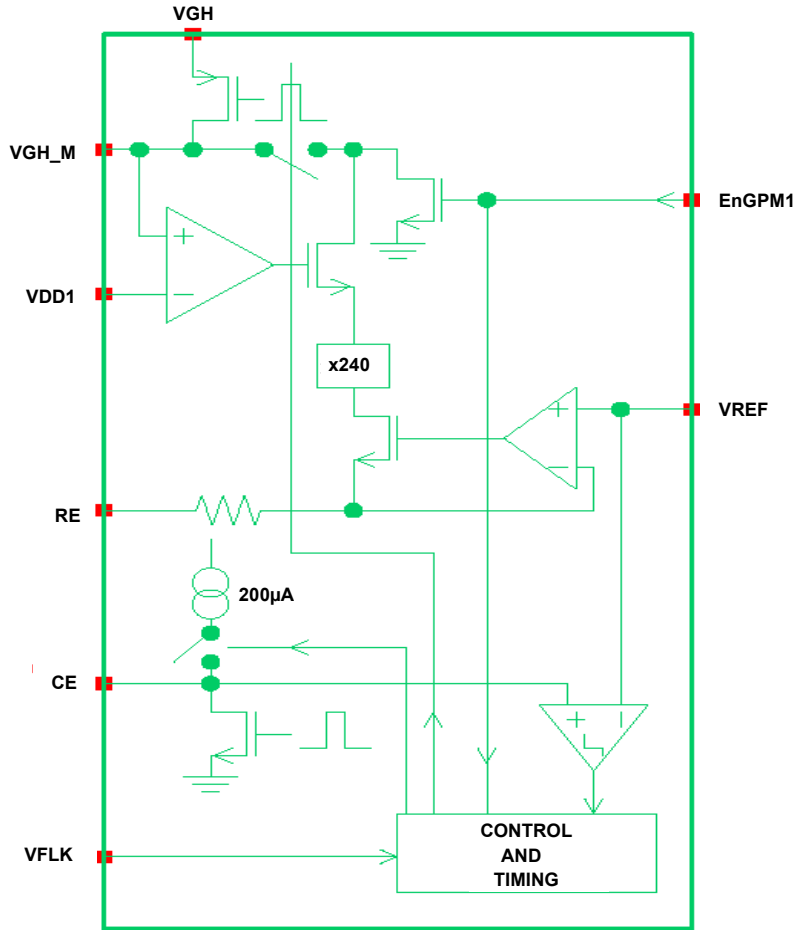

FIGURE 16. GATE PULSE MODULATOR CIRCUIT BLOCK DIAGRAM

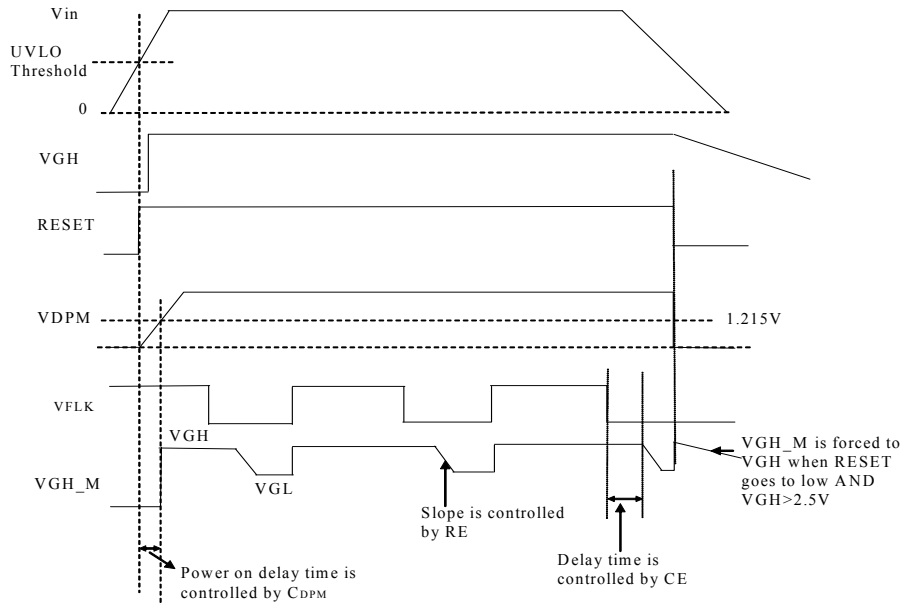

FIGURE 17. GATE PULSE MODULATOR TIMING DIAGRAM

TABLE 6. VGH\_M STATUS TABLE

V <sub>IN</sub>	VDPM	RESET	VGH	VGH_M	COMMENT
x	x	x	<2.5V	GROUND	Will be grounded if VIN is above a logic threshold. Could occur at power-up or power-down
>VLOR	<1.215V	x	>2.5V	GROUND	Start-up only condition: If either V <sub>IN</sub> > VLOR or reset is H, but VDPM < 1.215V, GND VGHM
x	<1.215V	High	>2.5V	GROUND	
>VLOR	>1.215V	High	>2.5V	Switching controlled by VFLK	
x	x	Low	>2.5V	VGH	Power-down state. Could occur at power-up if part starts with VGH > 2.5V

### Start-Up Sequence

When V<sub>IN</sub> exceeds VLOR and ENABLE reaches the VIH threshold value, Boost converter starts up, and gate pulse modulator circuit output holds until VDPM is charged to 1.215V. Note that there is a DC path in the boost converter from the input to the output through the inductor and diode, hence the input voltage will be seen at output with a forward voltage drop of diode before the part is enabled. If this voltage is not desired, the following circuit can be inserted between input and inductor to disconnect the DC path when the part is disabled.

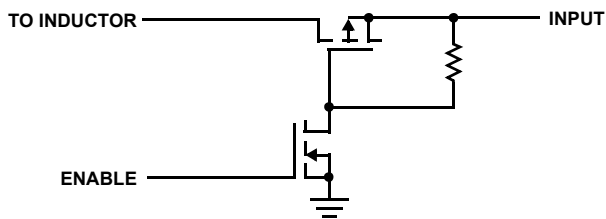

FIGURE 18. CIRCUIT TO DISCONNECT THE DC PATH OF BOOST CONVERTER

### V<sub>COM</sub> Amplifier

The V<sub>COM</sub> amplifier is designed to control the voltage on the back plate of an LCD display. This plate is capacitively coupled to the pixel drive voltage which alternately cycles positive and negative at the line rate for the display. Thus the amplifier must be capable of sourcing and sinking capacitive pulses of current, which can occasionally be quite large (a few 100mA for typical applications).

The ISL97645A V<sub>COM</sub> amplifier's output current is limited to 400mA. This limit level, which is roughly the same for sourcing and sinking, is included to maintain reliable operation of the part. It does not necessarily prevent a large temperature rise if the current is maintained. (In this case the whole chip may be shut down by the thermal trip to protect functionality.) If the display occasionally demands current pulses higher than this limit, the reservoir capacitor will provide the excess and the

amplifier will top the reservoir capacitor back up once the pulse has stopped. This will happen on the μs time scale in practical systems and for pulses 2 or 3 times the current limit, the V<sub>COM</sub> voltage will have settled again before the next line is processed.

### Fault Protection

ISL97645A provides the overall fault protections including over current protection and over-temperature protection.

An internal temperature sensor continuously monitors the die temperature. In the event that die temperature exceeds the thermal trip point, the device will shut down and disable itself. The upper and lower trip points are typically set to +140°C and +100°C respectively.

---

## Layout Recommendation

The device's performance including efficiency, output noise, transient response and control loop stability is dramatically affected by the PCB layout. PCB layout is critical, especially at high switching frequency.

There are some general guidelines for layout:

1. Place the external power components (the input capacitors, output capacitors, boost inductor and output diodes, etc.) in close proximity to the device. Traces to these components should be kept as short and wide as possible to minimize parasitic inductance and resistance.
2. Place  $V_{IN}$  and VDD bypass capacitors close to the pins.
3. Reduce the loop area with large AC amplitudes and fast slew rate.
4. The feedback network should sense the output voltage directly from the point of load, and be as far away from LX node as possible.
5. The power ground (PGND) and signal ground (SGND) pins should be connected at only one point.
6. The exposed die plate, on the underneath of the package, should be soldered to an equivalent area of metal on the PCB. This contact area should have multiple via connections to the back of the PCB as well as connections to intermediate PCB layers, if available, to maximize thermal dissipation away from the IC.
7. To minimize the thermal resistance of the package when soldered to a multi-layer PCB, the amount of copper track and ground plane area connected to the exposed die plate should be maximized and spread out as far as possible from the IC. The bottom and top PCB areas especially should be maximized to allow thermal dissipation to the surrounding air.
8. A signal ground plane, separate from the power ground plane and connected to the power ground pins only at the exposed die plate, should be used for ground return connections for control circuit.
9. Minimize feedback input track lengths to avoid switching noise pick-up.

A demo board is available to illustrate the proper layout implementation.

© Copyright Intersil Americas LLC 2007-2010. All Rights Reserved.  
All trademarks and registered trademarks are the property of their respective owners.

For additional products, see [www.intersil.com/en/products.html](http://www.intersil.com/en/products.html)

---

Intersil products are manufactured, assembled and tested utilizing ISO9001 quality systems as noted in the quality certifications found at [www.intersil.com/en/support/qualandreliability.html](http://www.intersil.com/en/support/qualandreliability.html)

---

*Intersil products are sold by description only. Intersil may modify the circuit design and/or specifications of products at any time without notice, provided that such modification does not, in Intersil's sole judgment, affect the form, fit or function of the product. Accordingly, the reader is cautioned to verify that datasheets are current before placing orders. Information furnished by Intersil is believed to be accurate and reliable. However, no responsibility is assumed by Intersil or its subsidiaries for its use; nor for any infringements of patents or other rights of third parties which may result from its use. No license is granted by implication or otherwise under any patent or patent rights of Intersil or its subsidiaries.*

---

For information regarding Intersil Corporation and its products, see [www.intersil.com](http://www.intersil.com)

# Package Outline Drawing

## L24.4x4D

24 LEAD QUAD FLAT NO-LEAD PLASTIC PACKAGE

Rev 2, 10/06

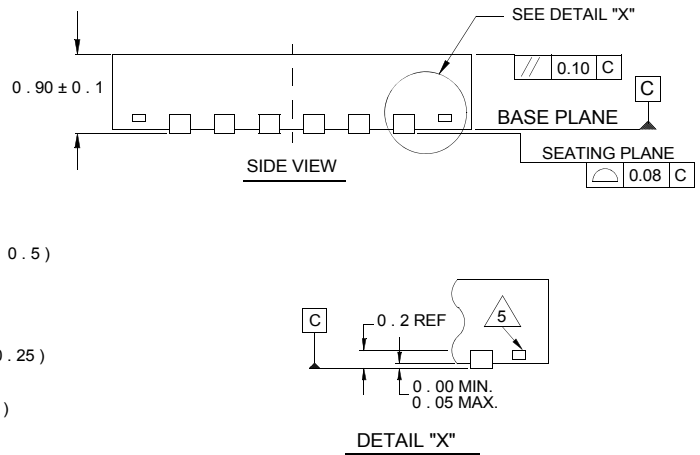
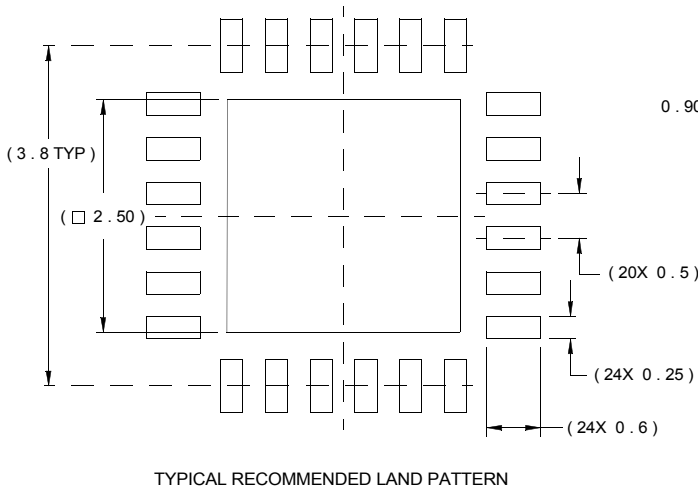
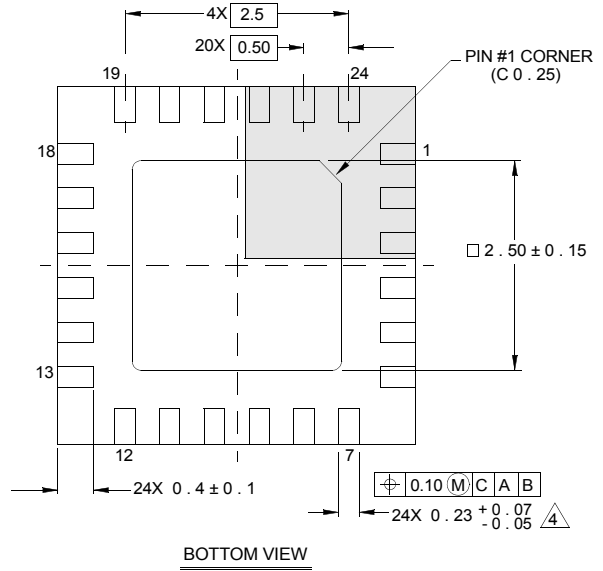
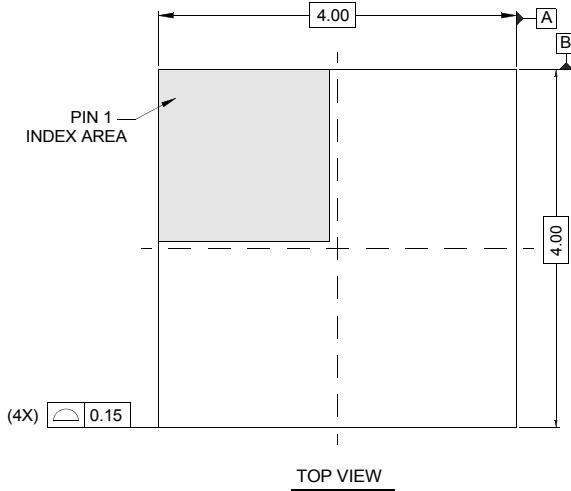

NOTES:

1. Dimensions are in millimeters.  
Dimensions in ( ) for Reference Only.
2. Dimensioning and tolerancing conform to AMSE Y14.5m-1994.
3. Unless otherwise specified, tolerance : Decimal ± 0.05
4. Dimension b applies to the metallized terminal and is measured between 0.15mm and 0.30mm from the terminal tip.
5. Tiebar shown (if present) is a non-functional feature.
6. The configuration of the pin #1 identifier is optional, but must be located within the zone indicated. The pin #1 identifier may be either a mold or mark feature.

## Looking for pricing, stock, or lifecycle information?

Click below to explore more details on WIN SOURCE:

 [View ISL97645AIRZ-T on WIN SOURCE](#)

 [Intersil Information](#)

## Optimize Your Supply Chain with WIN SOURCE Solutions

-  Global Sourcing Solution
-  Obsolete Management
-  Cost Control Management
-  Shortage Management
-  Alternative Solution
-  Excess Inventory Management