

ISO124 ± 10 -V Input, Precision Isolation Amplifier

1 Features

- 100% Tested for High-Voltage Breakdown
- Rated 1500 Vrms
- High IMR: 140 dB at 60 Hz
- Maximum Nonlinearity: 0.010%
- Bipolar Operation: $V_O = \pm 10$ V
- Packages: PDIP-16 and SOIC-28
- Ease of Use: Fixed Unity Gain Configuration
- Supply Range: ± 4.5 -V to ± 18 -V

2 Applications

- Industrial Process Control:
 - Transducer Isolator, Isolator for Thermocouples, RTDs, Pressure Bridges, and Flow Meters, 4-mA to 20-mA Loop Isolation
- Ground Loop Elimination
- Motor and SCR Control
- Power Monitoring
- PC-Based Data Acquisition
- Test Equipment

3 Description

The ISO124 is a precision isolation amplifier incorporating a novel duty cycle modulation-demodulation technique. The signal is transmitted digitally across a 2-pF differential capacitive barrier. With digital modulation, the barrier characteristics do not affect signal integrity, thus resulting in excellent reliability and good high-frequency transient immunity across the barrier. Both barrier capacitors are imbedded in the plastic body of the package.

The ISO124 is easy to use. No external components are required for operation. The key specifications are 0.010% maximum nonlinearity, 50-kHz signal bandwidth, and 200- μ V/ $^{\circ}$ C V_{OS} drift. A power supply range of ± 4.5 V to ± 18 V, and quiescent currents of ± 5 mA on V_{S1} and ± 5.5 mA on V_{S2} make the ISO124 device a good choice for a wide range of applications.

The ISO124 is available in 16-pin PDIP and 28-lead SOIC plastic surface-mount packages.

Device Information⁽¹⁾

PART NUMBER	PACKAGE	BODY SIZE (NOM)
ISO124	PDIP (16)	17.90 mm x 7.50 mm
	SOIC (28)	20.01 mm x 6.61 mm

(1) For all available packages, see the package option addendum at the end of the data sheet.

Simplified Schematic

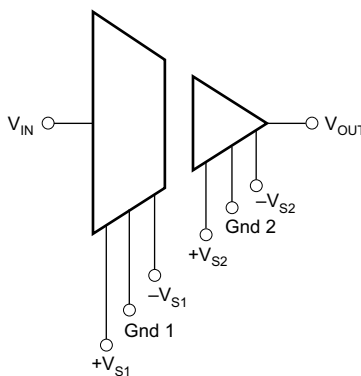

Table of Contents

1 Features 1 2 Applications 1 3 Description 1 4 Revision History 2 5 Pin Configuration and Functions 3 6 Specifications 4 6.1 Absolute Maximum Ratings 4 6.2 ESD Ratings 4 6.3 Recommended Operating Conditions 4 6.4 Thermal Information 4 6.5 Electrical Characteristics 5 6.6 Typical Characteristics 6 7 Detailed Description 8 7.1 Overview 8 7.2 Functional Block Diagram 9 7.3 Feature Description 9 7.4 Device Functional Modes 9	8 Application and Implementation 10 8.1 Application Information 10 8.2 Typical Applications 11 9 Power Supply Recommendations 19 9.1 Signal and Supply Connections 19 10 Layout 20 10.1 Layout Guidelines 20 10.2 Layout Example 20 11 Device and Documentation Support 21 11.1 Documentation Support 21 11.2 Receiving Notification of Documentation Updates 21 11.3 Community Resources 21 11.4 Trademarks 21 11.5 Electrostatic Discharge Caution 21 11.6 Glossary 21 12 Mechanical, Packaging, and Orderable Information 21
--	---

4 Revision History

Changes from Revision D (July 2016) to Revision E	Page
• Changed 16-pin SOIC package to 16-pin PDIP package to match content shown in package option addendum at the end of the data sheet.....	1
• Changed DVA and NVF pin configuration labels to match content shown in the package option addendum at the end of the data sheet.....	3
• Changed parameter name from "vs temperature" to "Input offset drift" in <i>Electrical Characteristics</i> table.....	5
• Changed parameter name from "vs power supply" to "Power-supply rejection ratio" in <i>Electrical Characteristics</i> table.....	5
• Changed location of supply voltage specifications from the <i>Electrical Characteristics</i> table to the <i>Recommended Operating Conditions</i> table.....	5
• Changed parameter name from "Quiescent current" to "High-side analog supply current", and changed symbol from "V _{S1} " to "I _{VS1} " in <i>Electrical Characteristics</i> table.....	5
• Changed parameter name from "Quiescent current" to "Low-side analog supply current", and changed symbol from "V _{S2} " to "I _{VS2} " in <i>Electrical Characteristics</i> table.....	5
• Changed location of Temperature specifications from the <i>Electrical Characteristics</i> table to the <i>Recommended Operating Conditions</i> table.....	5
• Deleted Thermal resistance parameters from <i>Electrical Characteristics</i> table; see <i>Thermal Information</i> table.....	5

Changes from Revision C (September 2005) to Revision D	Page
• Added <i>ESD Ratings</i> table, <i>Feature Description</i> section, <i>Device Functional Modes</i> , <i>Application and Implementation</i> section, <i>Power Supply Recommendations</i> section, <i>Layout</i> section, <i>Device and Documentation Support</i> section, and <i>Mechanical, Packaging, and Orderable Information</i> section.	1

5 Pin Configuration and Functions

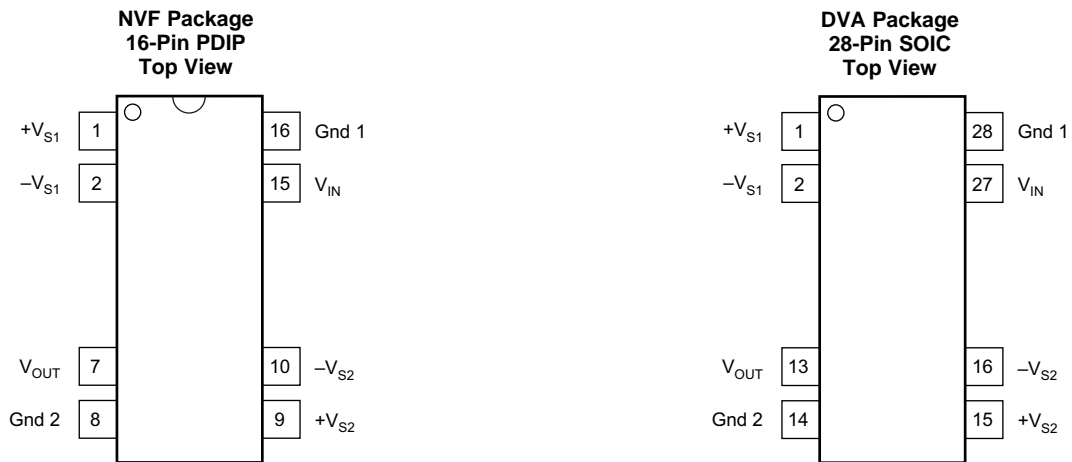

Pin Functions

NAME	PIN		I/O	DESCRIPTION
	PDIP	SOIC		
Gnd 1	16	28	—	High-side ground reference
Gnd 2	8	14	—	Low-side ground reference
V _{IN}	15	27	I	High-side analog input
V _{OUT}	7	13	O	Low-side analog output
+V _{S1}	1	1	—	High-side positive analog supply
-V _{S1}	2	2	—	High-side negative analog supply
+V _{S2}	9	15	—	Low-side positive analog supply
-V _{S2}	10	16	—	Low-side negative analog supply

6 Specifications

6.1 Absolute Maximum Ratings

over operating free-air temperature range (unless otherwise noted) ⁽¹⁾

	MIN	MAX	UNIT
Supply voltage		±18	V
Analog input voltage, V_{IN}		100	V
Continuous isolation voltage		1500	V _{rms}
Junction temperature		125	°C
Output short to common		Continuous	
Storage temperature, T_{stg}	–40	125	°C

- (1) Stresses beyond those listed under *Absolute Maximum Ratings* may cause permanent damage to the device. These are stress ratings only, which do not imply functional operation of the device at these or any other conditions beyond those indicated under *Recommended Operating Conditions*. Exposure to absolute-maximum-rated conditions for extended periods may affect device reliability.

6.2 ESD Ratings

		VALUE	UNIT
$V_{(ESD)}$ Electrostatic discharge	Human body model (HBM), per ANSI/ESDA/JEDEC JS-001 ⁽¹⁾	±1000	V
	Charged-device model (CDM), per JEDEC specification JESD22-C101 ⁽²⁾	±500	

- (1) JEDEC document JEP155 states that 500-V HBM allows safe manufacturing with a standard ESD control process.
 (2) JEDEC document JEP157 states that 250-V CDM allows safe manufacturing with a standard ESD control process.

6.3 Recommended Operating Conditions

over operating free-air temperature range (unless otherwise noted)

		MIN	NOM	MAX	UNIT
V_{S1}	High-side analog supply voltage ($\pm V_{S1}$ to GND1)	±4.5	±15	±18	V
V_{S2}	Low-side analog supply voltage ($\pm V_{S2}$ to GND2)	±4.5	±15	±18	V
V_{IN}	Analog input voltage		±10		V
T_A	Operating temperature	–25		85	°C

6.4 Thermal Information

THERMAL METRIC ⁽¹⁾		ISO124		UNIT
		DVA (SOIC)	NVF (PDIP)	
		28 PINS	16 PINS	
$R_{\theta JA}$	Junction-to-ambient thermal resistance	79.8	51.0	°C/W
$R_{\theta JC(top)}$	Junction-to-case (top) thermal resistance	32.9	32.4	°C/W
$R_{\theta JB}$	Junction-to-board thermal resistance	42.2	29.5	°C/W
ψ_{JT}	Junction-to-top characterization parameter	6.6	10.4	°C/W
ψ_{JB}	Junction-to-board characterization parameter	40.9	29.0	°C/W

- (1) For more information about traditional and new thermal metrics, see the [Semiconductor and IC Package Thermal Metrics](#) application report.

6.5 Electrical Characteristics

at $T_A = +25^\circ\text{C}$, $V_{S1} = V_{S2} = \pm 15\text{ V}$, and $R_L = 2\text{ k}\Omega$ (unless otherwise noted)

PARAMETER		TEST CONDITIONS	MIN	TYP	MAX	UNIT
ISOLATION						
Rated voltage		Continuous ac 60 Hz	1500			Vac
100% test ⁽¹⁾		Test time = 1 s, partial discharge $\leq 5\text{ pC}$	2400			Vac
Isolation mode rejection		60 Hz	140			dB
Barrier impedance			$10^{14} \parallel 2$			$\Omega \parallel \text{pF}$
Leakage current at 60 Hz		$V_{\text{ISO}} = 240\text{ V}_{\text{rms}}$	0.18	0.5		μArms
GAIN						
Nominal gain		$V_O = \pm 10\text{ V}$	1			V/V
Gain error		$V_O = \pm 10\text{ V}$	± 0.05	± 0.50		%FSR
Gain vs temperature			± 10			ppm/ $^\circ\text{C}$
Nonlinearity ⁽²⁾			± 0.005	± 0.010		%FSR
INPUT OFFSET VOLTAGE						
Initial offset			± 20	± 50		mV
Input offset drift			± 200			$\mu\text{V}/^\circ\text{C}$
PSR R	Power-supply rejection ratio		± 2			mV/V
	Noise		4			$\mu\text{V}/\sqrt{\text{Hz}}$
INPUT						
Input voltage			± 10	± 12.5		V
Resistance			200			k Ω
OUTPUT						
Output voltage			± 10	± 12.5		V
Current drive			± 5	± 15		mA
Capacitive load drive			0.1			μF
Ripple voltage ⁽³⁾			20			mVp-p
FREQUENCY RESPONSE						
Small-signal bandwidth			50			kHz
Slew rate			2			V/ μs
Settling Time 0.10%		$V_O = \pm 10\text{ V}$	50			μs
Settling Time 0.01%		$V_O = \pm 10\text{ V}$	350			μs
Overload recovery time			150			μs
POWER SUPPLIES						
$I_{V_{S1}}$	High-side analog supply current		± 5.0	± 7.0		mA
$I_{V_{S2}}$	Low-side analog supply current		± 5.5	± 7.0		mA

(1) Tested at 1.6x rated, fail on 5-pC partial discharge.

(2) Nonlinearity is the peak deviation of the output voltage from the best-fit straight line, and is expressed as the ratio of deviation to FSR.

(3) Ripple frequency is at carrier frequency (500 kHz).

6.6 Typical Characteristics

at $T_A = +25^\circ\text{C}$, and $V_S = \pm 15\text{ V}$ (unless otherwise noted)

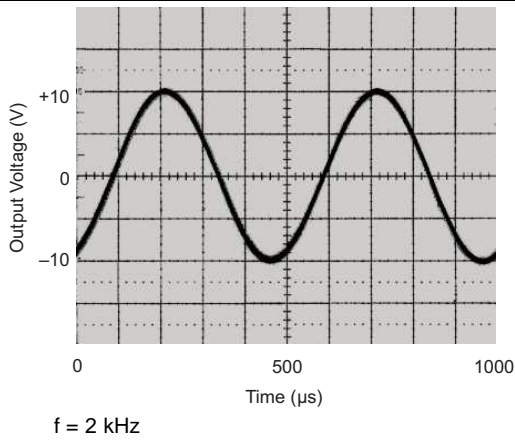

Figure 1. Sine Response

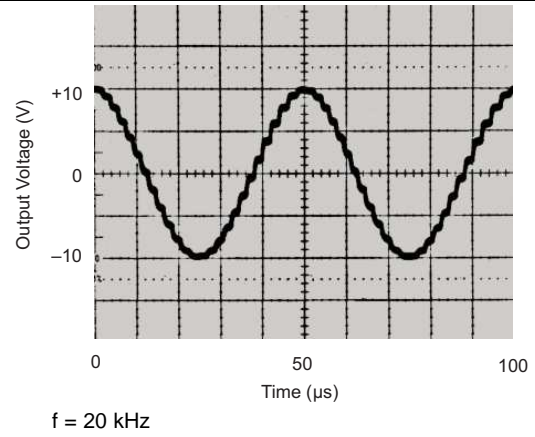

Figure 2. Sine Response

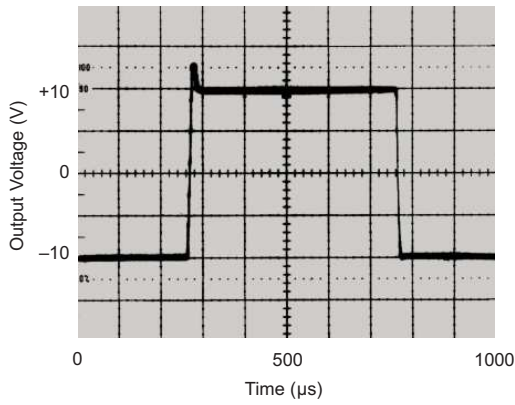

Figure 3. Step Response

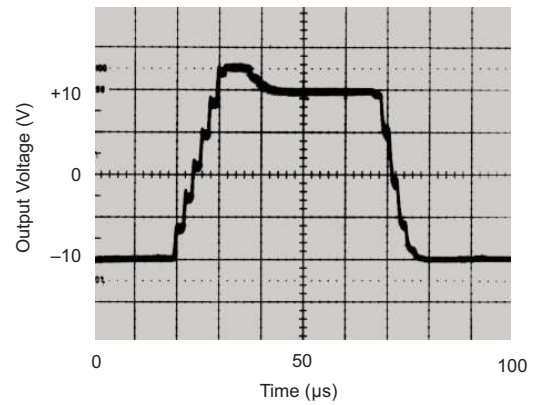

Figure 4. Step Response

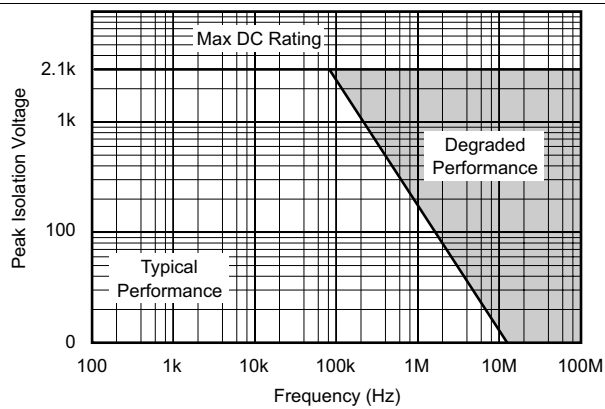

Figure 5. Isolation Voltage vs Frequency

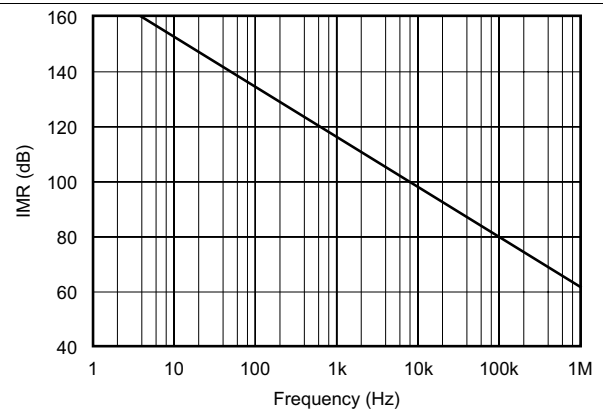

Figure 6. IMR vs Frequency

Typical Characteristics (continued)

at $T_A = +25^\circ\text{C}$, and $V_S = \pm 15\text{ V}$ (unless otherwise noted)

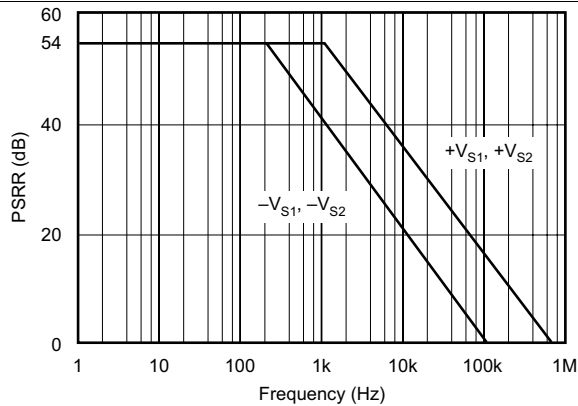

Figure 7. PSRR vs Frequency

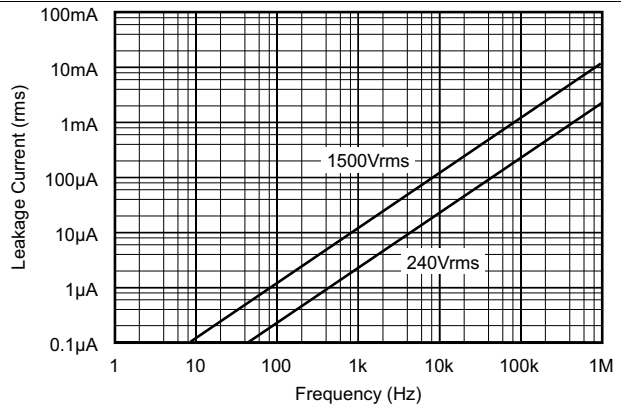
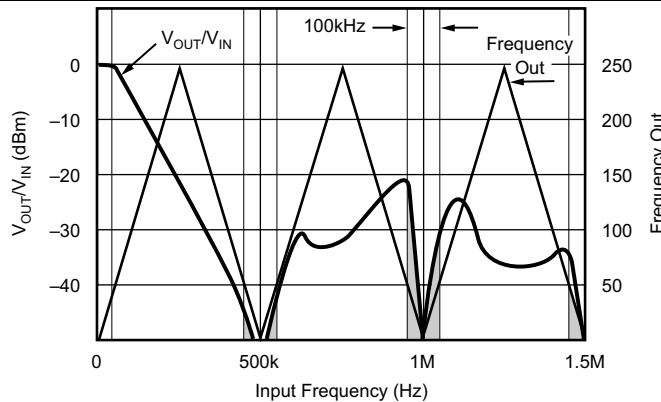

Figure 8. Isolation Leakage Current vs Frequency



NOTE: Shaded area shows aliasing frequencies that cannot be removed by a low-pass filter at the output.

Figure 9. Signal Response to Inputs Greater than 250 kHz

7 Detailed Description

7.1 Overview

The ISO124 isolation amplifier uses an input and an output section galvanically isolated by matched 1-pF isolating capacitors built into the plastic package. The input is duty-cycle modulated and transmitted digitally across the barrier. The output section receives the modulated signal, converts it back to an analog voltage and removes the ripple component inherent in the demodulation. Input and output sections are fabricated, then laser trimmed for exceptional circuitry matching common to input and output sections. The sections are then mounted on opposite ends of the package with the isolating capacitors mounted between the two sections. The ISO124 contains 250 transistors.

7.1.1 Modulator

An input amplifier (A1, as shown in [Functional Block Diagram](#)) integrates the difference between the input current ($V_{IN}/200\text{ k}\Omega$) and a switched $\pm 100\text{-}\mu\text{A}$ current source. This current source is implemented by a switchable $200\text{-}\mu\text{A}$ source and a fixed $100\text{-}\mu\text{A}$ current sink. To understand the basic operation of the modulator, assume that $V_{IN} = 0\text{ V}$. The integrator will ramp in one direction until the comparator threshold is exceeded. The comparator and sense amp will force the current source to switch; the resultant signal is a triangular waveform with a 50% duty cycle. The internal oscillator forces the current source to switch at 500 kHz. The resultant capacitor drive is a complementary duty-cycle modulation square wave.

7.1.2 Demodulator

The sense amplifier detects the signal transitions across the capacitive barrier and drives a switched current source into integrator A2. The output stage balances the duty-cycle modulated current against the feedback current through the $200\text{-k}\Omega$ feedback resistor, resulting in an average value at the V_{OUT} pin equal to V_{IN} . The sample-and-hold amplifiers in the output feedback loop serve to remove undesired ripple voltages inherent in the demodulation process.

7.2 Functional Block Diagram

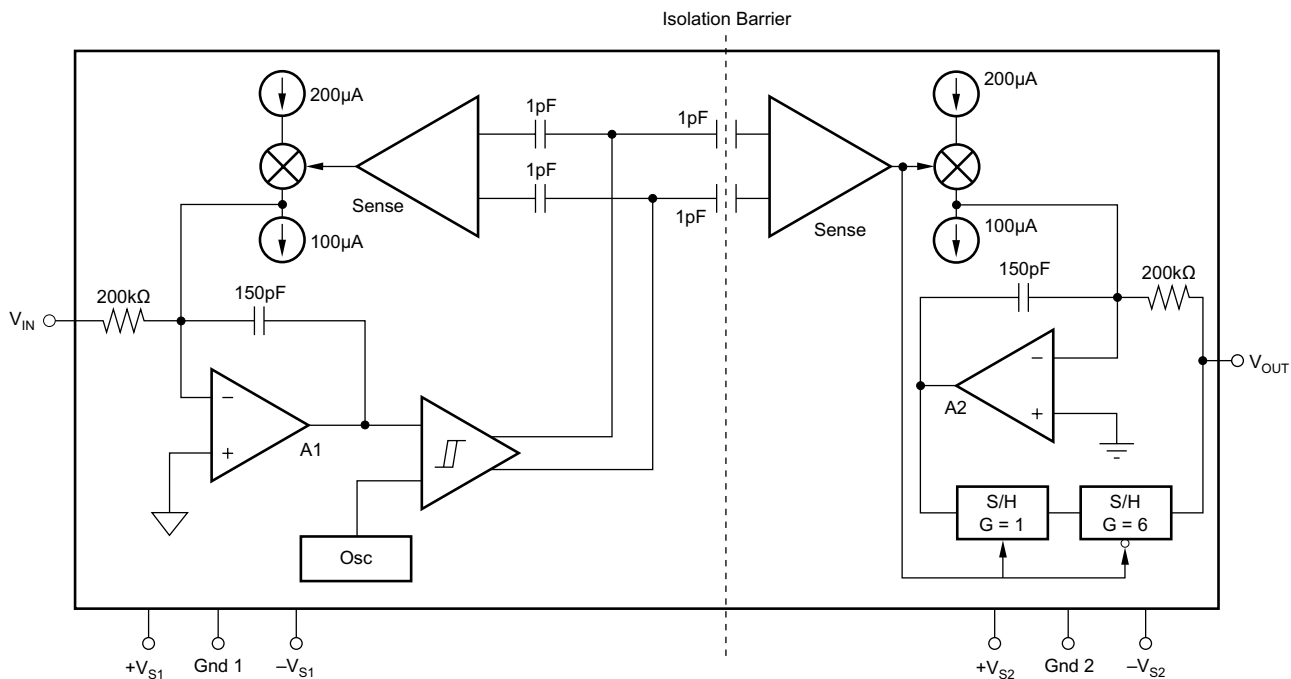

7.3 Feature Description

7.3.1 Isolation Amplifier

The ISO124 is a precision analog isolation amplifier. The input signal is transmitted digitally across a high-voltage differential capacitive barrier. With digital modulation, the barrier characteristics do not affect signal integrity, resulting in excellent reliability and high-frequency transient immunity.

7.4 Device Functional Modes

The ISO124 device does not have any additional functional modes.

8 Application and Implementation

NOTE

Information in the following applications sections is not part of the TI component specification, and TI does not warrant its accuracy or completeness. TI's customers are responsible for determining suitability of components for their purposes. Customers should validate and test their design implementation to confirm system functionality.

8.1 Application Information

8.1.1 Carrier Frequency Considerations

The ISO124 amplifier transmits the signal across the isolation barrier by a 500-kHz duty-cycle modulation technique. For input signals having frequencies below 250 kHz, this system works like any linear amplifier. But for frequencies above 250 kHz, the behavior is similar to that of a sampling amplifier. [Figure 9](#) shows this behavior graphically; at input frequencies above 250 kHz, the device generates an output signal component of reduced magnitude at a frequency below 250 kHz. This is the aliasing effect of sampling at frequencies less than two times the signal frequency (the Nyquist frequency). At the carrier frequency and its harmonics, both the frequency and amplitude of the aliasing go to zero.

8.1.2 Isolation Mode Voltage Induced Errors

IMV can induce errors at the output as indicated by the plots of IMV vs Frequency. It should be noted that if the IMV frequency exceeds 250 kHz, the output also will display spurious outputs (aliasing) in a manner similar to that for $V_{IN} > 250$ kHz and the amplifier response will be identical to that shown in [Figure 9](#). This occurs because IMV-induced errors behave like input-referred error signals. To predict the total error, divide the isolation voltage by the IMR shown in [Figure 11](#) and compute the amplifier response to this input-referred error signal from the data shown in [Figure 9](#). For example, if a 800-kHz 1000-Vrms IMR is present, then a total of $[(-60 \text{ dB}) + (-30 \text{ dB})] \times (1000 \text{ V}) = 32\text{-mV}$ error signal at 200 kHz plus a 1-V, 800-kHz error signal will be present at the output.

8.1.3 High IMV dV/dt Errors

As the IMV frequency increases and the dV/dt exceeds 1000 V/ μ s, the sense amp may start to false trigger, and the output will display spurious errors. The common-mode current being sent across the barrier by the high slew rate is the cause of the false triggering of the sense amplifier. Lowering the power-supply voltages below ± 15 V may decrease the dV/dt to 500 V/Ms for typical performance.

8.1.4 High Voltage Testing

TI has adopted a partial discharge test criterion that conforms to the German VDE0884 Optocoupler Standards. This method requires the measurement of minute current pulses (< 5 pC) while applying 2400-Vrms, 60-Hz high-voltage stress across every ISO124 isolation barrier. No partial discharge may be initiated to pass this test. This criterion confirms transient overvoltage (1.6×1500 Vrms) protection without damage to the ISO124. Lifetest results verify the absence of failure under continuous rated voltage and maximum temperature.

This new test method represents the “state-of-the art” for nondestructive high-voltage reliability testing. It is based on the effects of nonuniform fields that exist in heterogeneous dielectric material during barrier degradation. In the case of void nonuniformities, electric field stress begins to ionize the void region before bridging the entire high-voltage barrier. The transient conduction of charge during and after the ionization can be detected externally as a burst of 0.01–0.1- μ s current pulses that repeat on each ac voltage cycle. The minimum ac barrier voltage that initiates partial discharge is defined as the “inception voltage.” Decreasing the barrier voltage to a lower level is required before partial discharge ceases and is defined as the “extinction voltage.” The package insulation processes have been characterized and developed to yield an inception voltage in excess of 2400 Vrms so that transient overvoltages below this level will not damage the ISO124. The extinction voltage is above 1500 Vrms so that even overvoltage induced partial discharge will cease once the barrier voltage is reduced to the 1500-Vrms (rated) level. Older high-voltage test methods relied on applying a large enough overvoltage (above rating) to break down marginal parts, but not so high as to damage good ones. Our new partial discharge testing gives us more confidence in barrier reliability than breakdown/no breakdown criteria.

8.2 Typical Applications

8.2.1 Output Filters

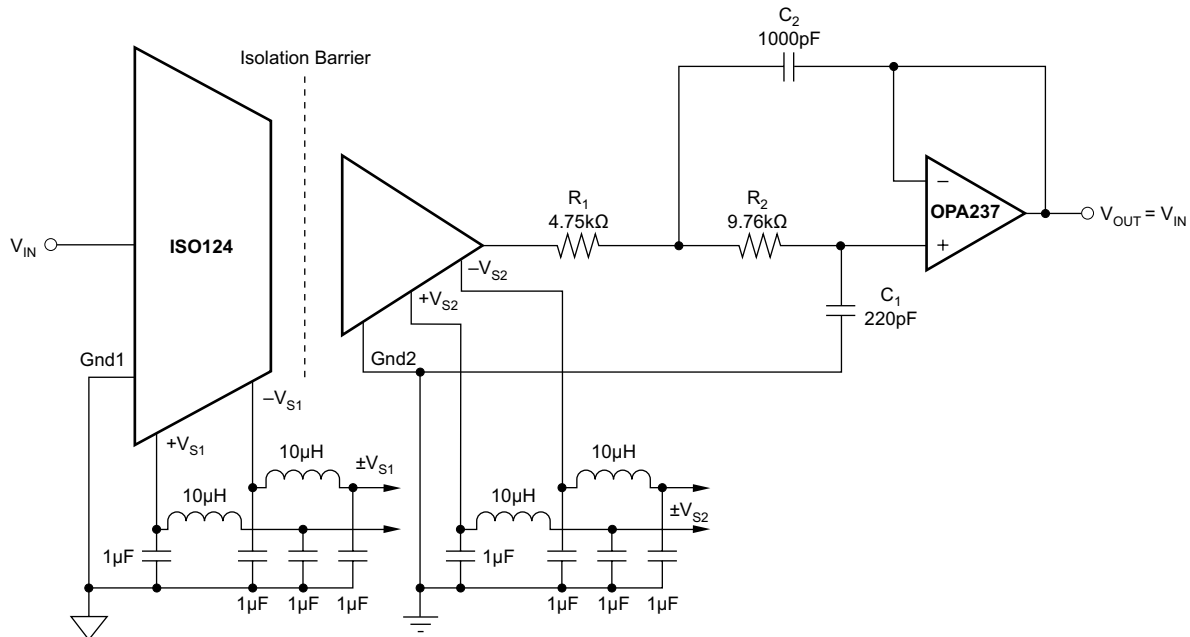

For more information concerning output filters, see [Simple Output Filter Eliminates ISO Amp Output Ripple and Keeps Full Bandwidth](#) and [FilterPro™ MFB and Sallen-Key Low-Pass Filter Design Program User Guide](#).

Figure 10. ISO124 With Output Filter for Improved Ripple

8.2.1.1 Design Requirements

The ISO124 isolation amplifiers (ISO amps) have a small (10 to 20 mVp-p typical) residual demodulator ripple at the output. A simple filter can be added to eliminate the output ripple without decreasing the 50kHz signal bandwidth of the ISO amp.

8.2.1.2 Detailed Design Procedure

The ISO124 device is designed to have a 50-kHz single-pole (Butterworth) signal response. By cascading the ISO amp with a simple 50-kHz, $Q = 1$, two-pole, low-pass filter, the overall signal response becomes three-pole Butterworth. The result is a maximally flat 50-kHz magnitude response and the output ripple reduced below the noise level. [Figure 10](#) shows the complete circuit. The two-pole filter is a unity-gain Sallen-Key type consisting of A1, R1, R2, C1, and C2. The values shown give $Q = 1$ and f_{-3dB} bandwidth = 50 kHz. Because the op amp is connected as a unity-gain follower, gain and gain accuracy of the ISO amp are unaffected. Using a precision op amp such as the OPA602 also preserves the DC accuracy of the ISO amp.

Typical Applications (continued)

8.2.1.3 Application Curves

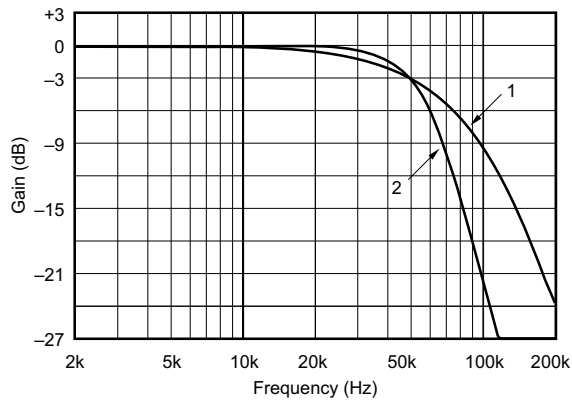

- 1) Standard ISO124 has 50kHz single-pole (Butterworth) response.
- 2) ISO124 with cascaded 50kHz, Q = 1, two-pole, low-pass filter has three-pole Butterworth response.

Figure 11. Gain vs. Frequency

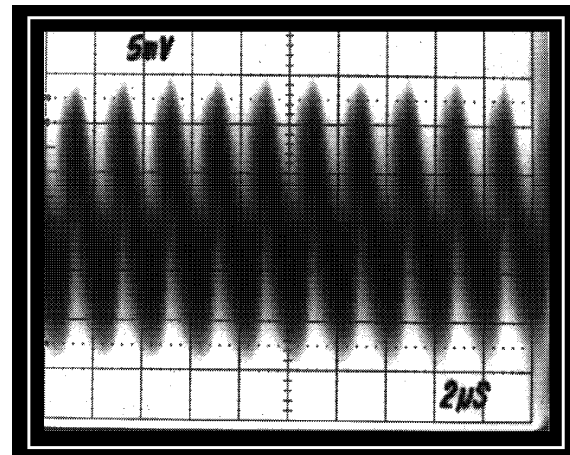

Figure 12. Standard ISO124 (Approximately 20-mVp-p Output Ripple)

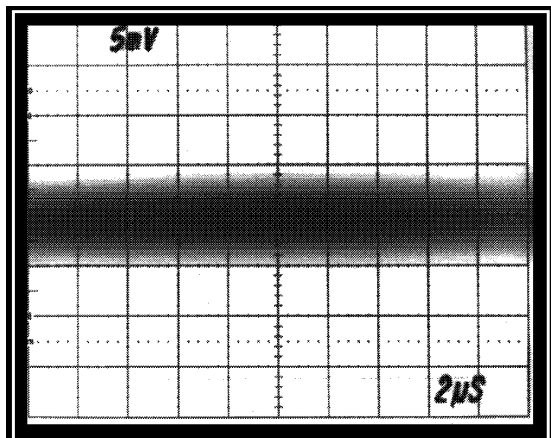

Figure 13. Filtered ISO124 (No Visible Output Ripple)

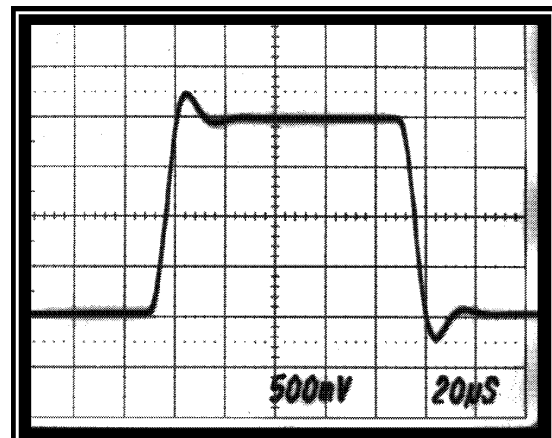

Figure 14. Step Response of Standard ISO124

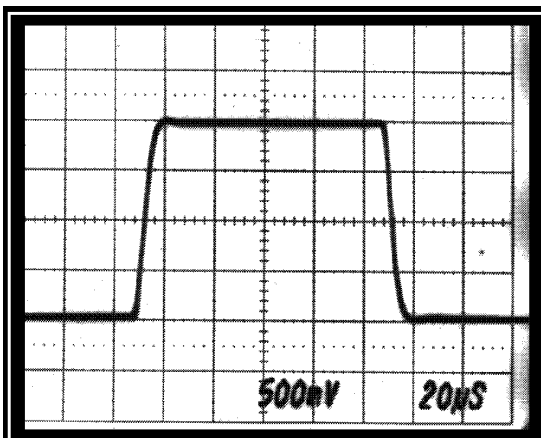

Figure 15. Step Response of ISO124 With Added Twopole Output Filter

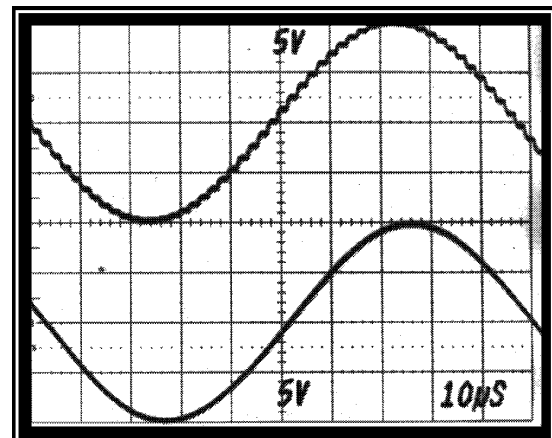
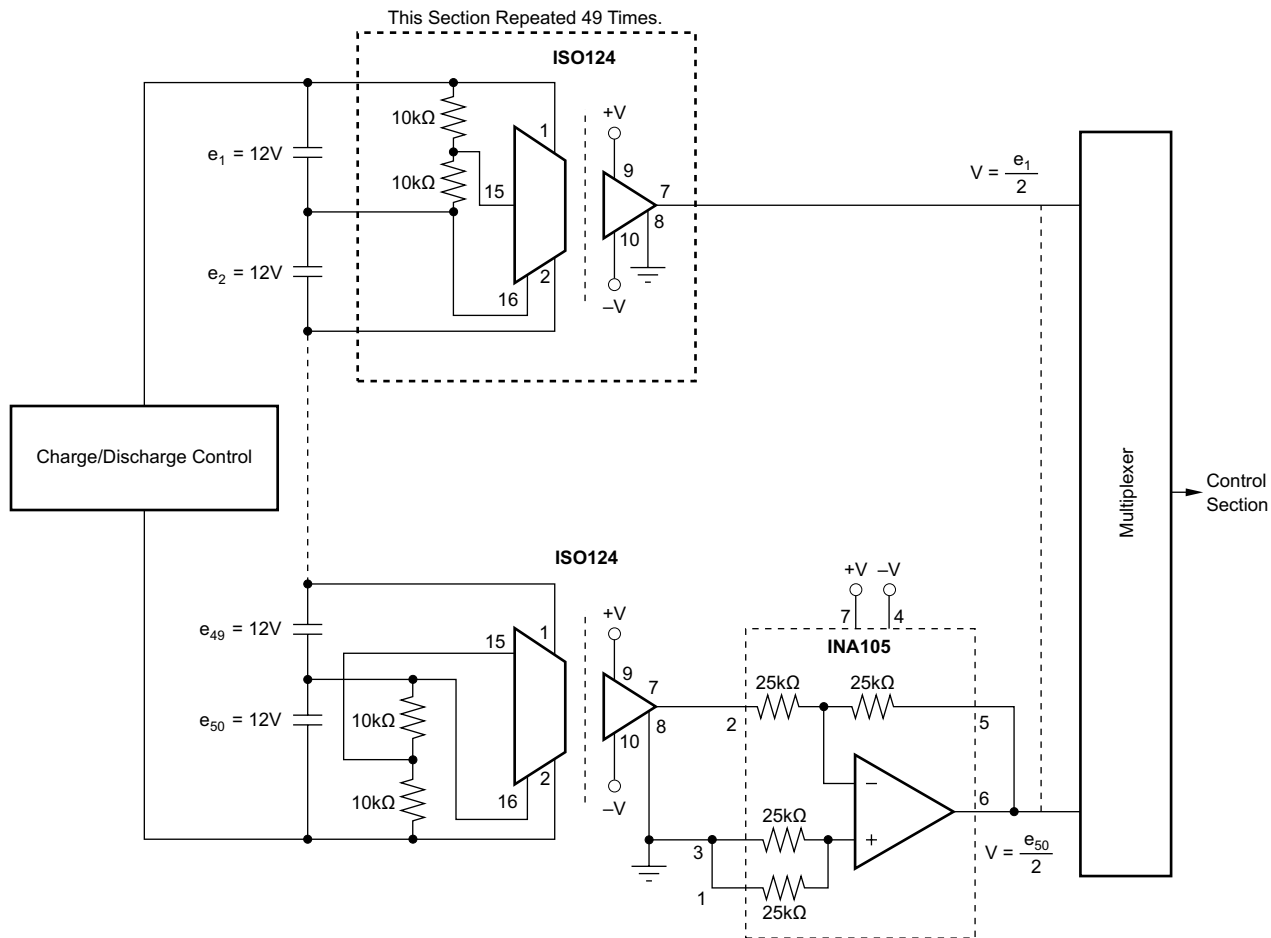

Figure 16. Large-signal, 10-kHz Sine-wave Response of ISO124 With and Without Output Filter

Typical Applications (continued)

8.2.2 Battery Monitor

Figure 17 provides a means to monitor the cell voltage on a 600-V battery stack by using the battery as a power source for the isolated voltage.



(Derives input power from the battery.)

Figure 17. Battery Monitor for a 600-V Battery Power System

Typical Applications (continued)

8.2.3 Programmable Gain Amplifier

In applications where variable gain configurations are required, a programmable gain amplifier like the PGA102 can be used with the ISO124 device. Figure 18 uses an ISO150 device to provide gain pin selection options to the PGA102 device.

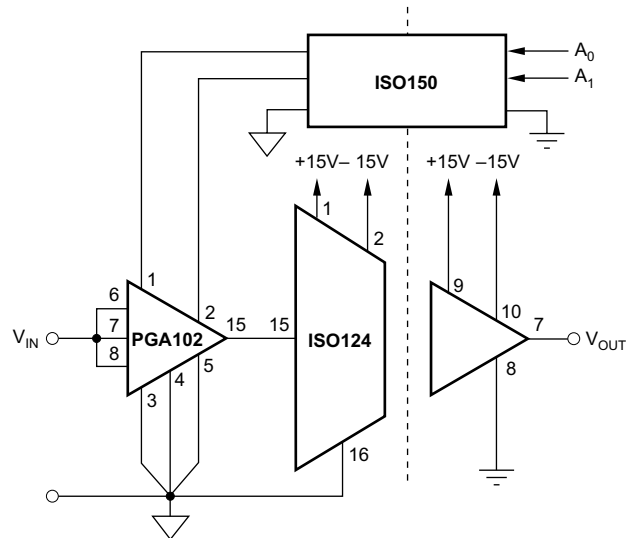

Figure 18. Programmable-Gain Isolation Channel With Gains of 1, 10, and 100

Typical Applications (continued)

8.2.4 Thermocouple Amplifier

For isolated temperature measurements, [Figure 19](#) provides an application solution using the INA114 or INA128 devices, feeding the input stage of the ISO124 device. The table provides suggested resistor values based on the type of thermistor used in the application.

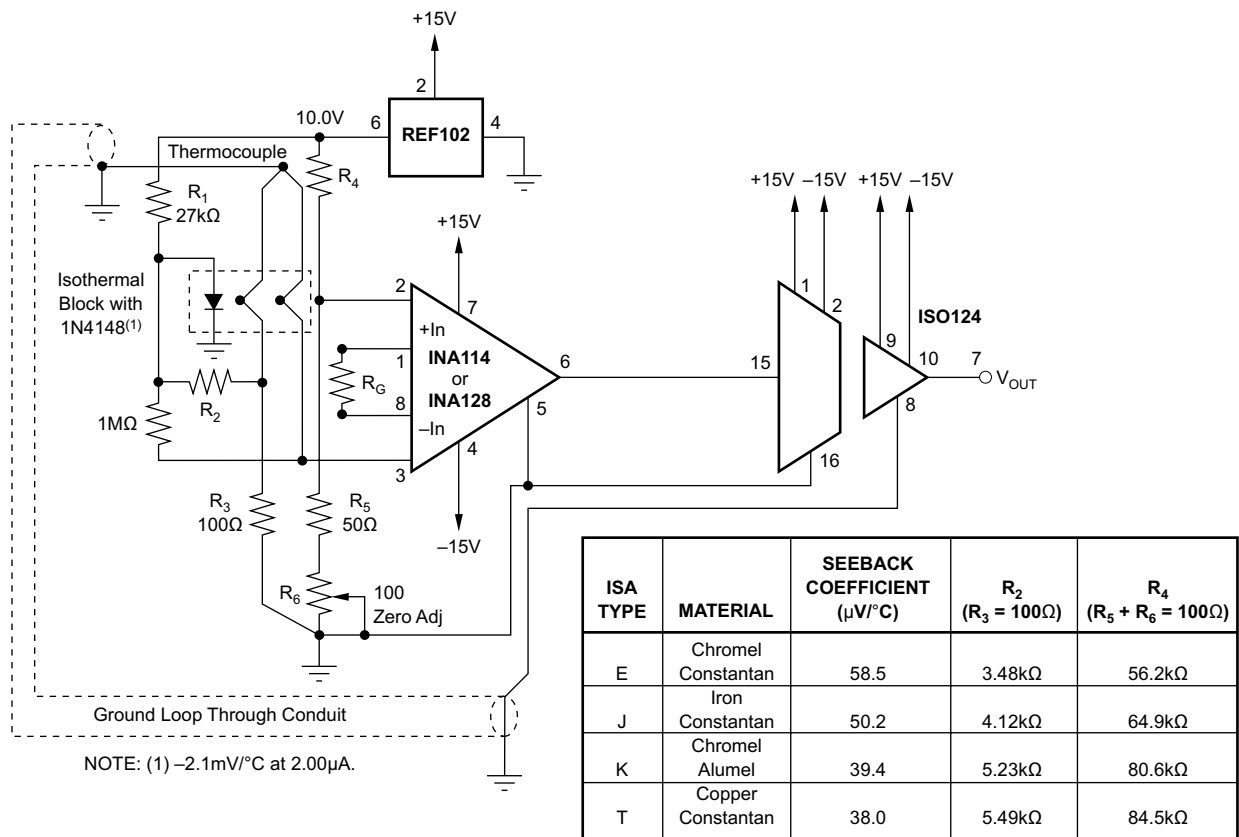

Figure 19. Thermocouple Amplifier With Ground Loop Elimination, Cold Junction Compensation, and Up-scale Burn-out

Typical Applications (continued)

8.2.5 Isolated 4-mA to 20-mA Instrument Loop

For isolated temperature measurements in a 4-mA to 20-mA loop, [Figure 20](#) provides a solution using the XTR101 and RCV420 devices. A high-performance PT100 resistance temperature detector (RTD) provides the user with an isolated 0-V to 5-V representation of the isolated temperature measurement.

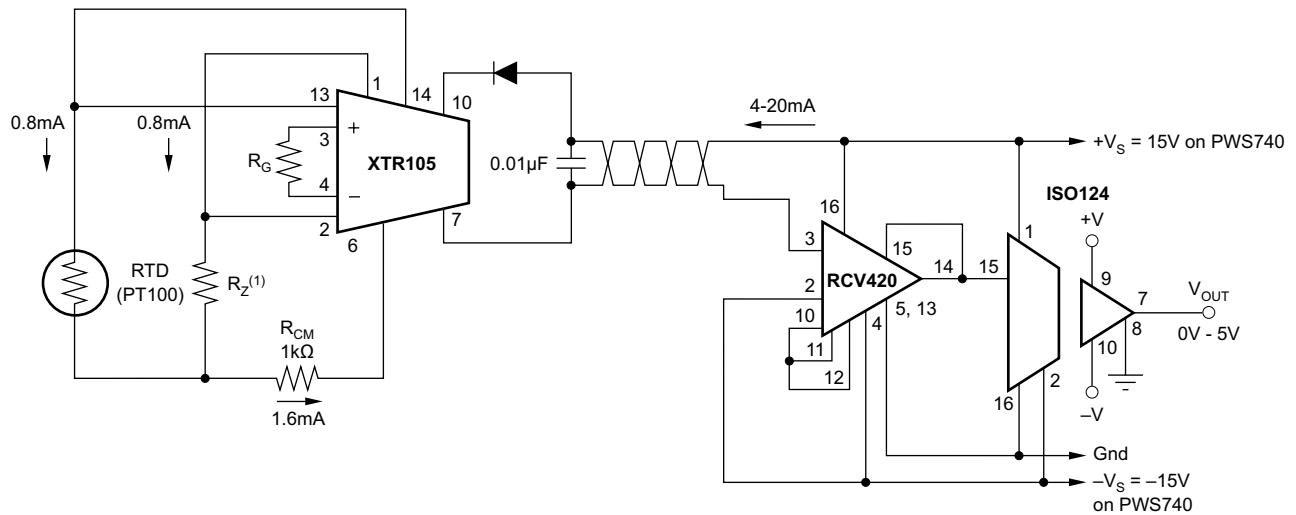
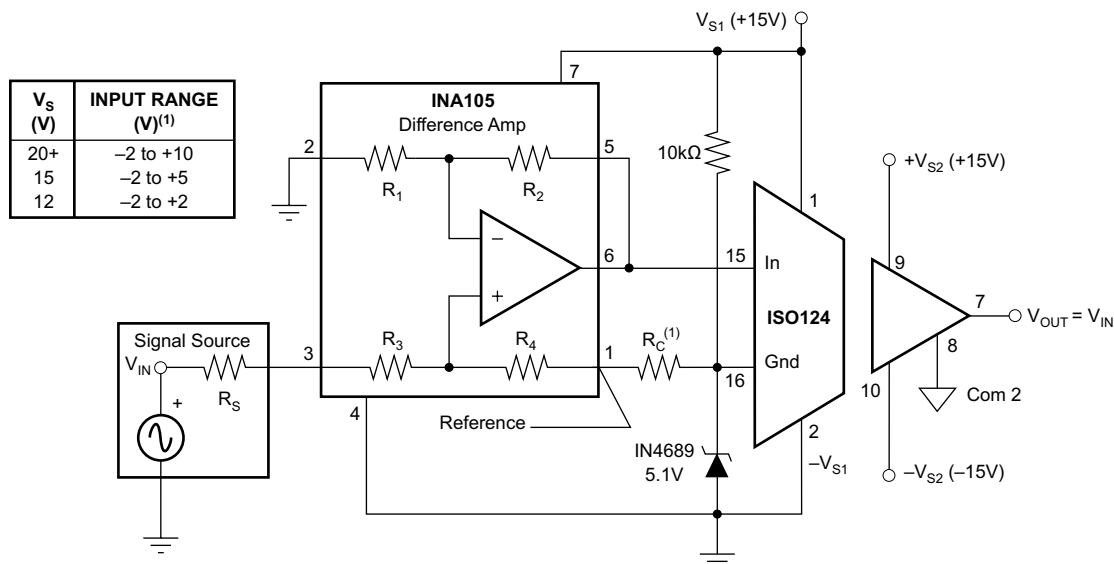

Figure 20. Isolated 4- to 20-mA Instrument Loop (RTD Shown)

8.2.6 Single-Supply Operation of the ISO124 Isolation Amplifier

The circuit shown in [Figure 21](#) uses a 5.1-V Zener diode to generate the negative supply for an ISO12x from a single supply on the high-voltage side of the isolation amplifier. The input measuring range will be dependent on the applied voltage as noted in the accompanying table.



NOTE: Because the amplifier is unity gain, the input range is also the output range. The output can go to -2 V because the output section of the ISO amp operates from dual supplies.

For additional information see [Single-Supply Operation of Isolation Amplifiers](#).

Figure 21. Single-Supply Operation of the ISO124 Isolation Amplifier Schematic

Typical Applications (continued)

8.2.7 Input-Side Powered ISO Amplifier

The user side of the ISO124 device can be powered from the high voltage side using an isolated DC-DC converter as shown in Figure 22.

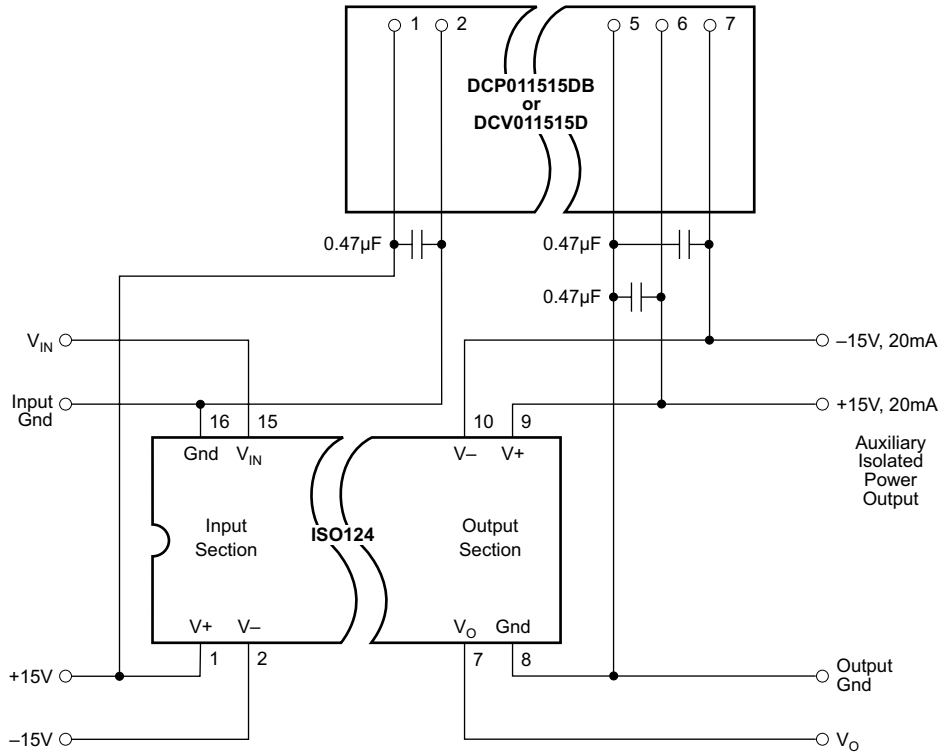

Figure 22. Input-Side Powered ISO Amplifier Schematic

Typical Applications (continued)

8.2.8 Powered ISO Amplifier With Three-Port Isolation

Figure 23 illustrates an application solution that provides isolated power to both the user and high-voltage sides of the ISO124 amplifier.

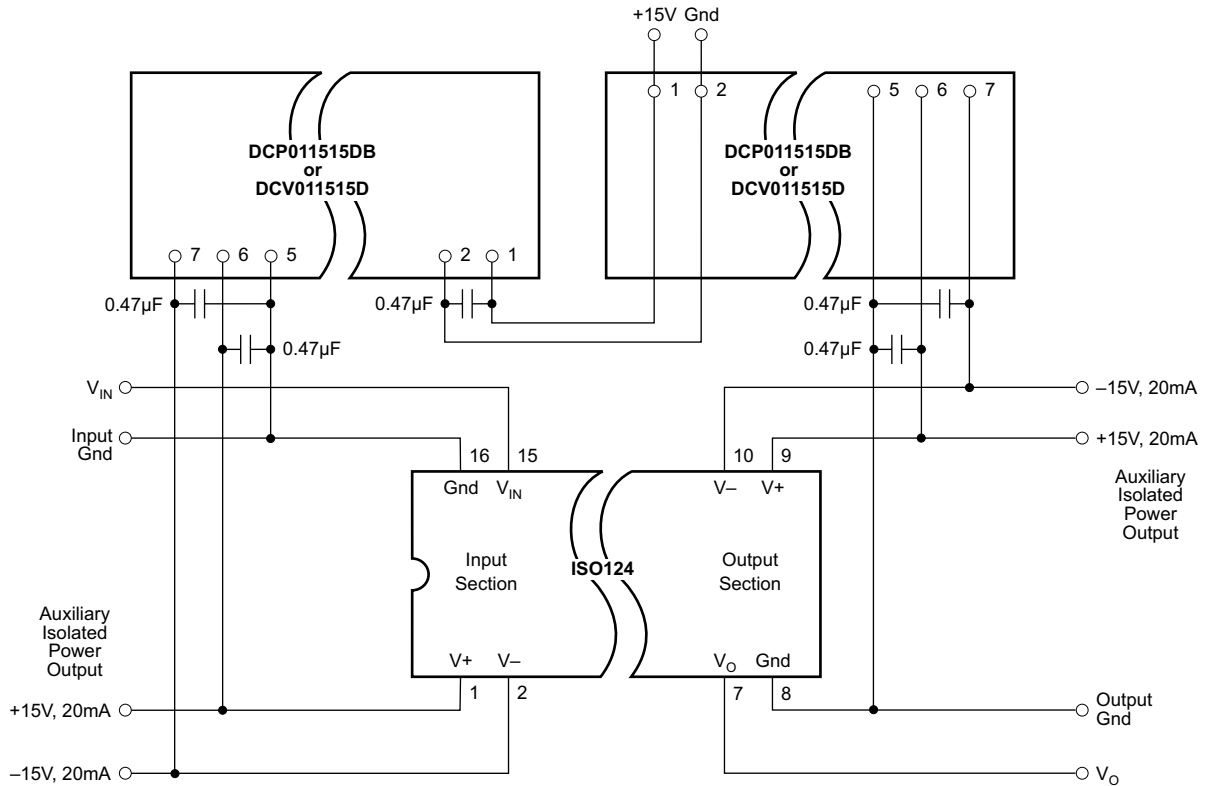

Figure 23. Powered ISO Amplifier With Three-Port Isolation Schematic

9 Power Supply Recommendations

9.1 Signal and Supply Connections

Each power-supply pin should be bypassed with 1- μF tantalum capacitors located as close to the amplifier as possible. The internal frequency of the modulator/demodulator is set at 500 kHz by an internal oscillator. Therefore, if it is desired to minimize any feedthrough noise (beat frequencies) from a DC-DC converter, use a π filter on the supplies (see Figure 10). The ISO124 output has a 500-kHz ripple of 20 mV, which can be removed with a simple 2-pole low-pass filter with a 100-kHz cutoff using a low-cost op amp (see Figure 10).

The input to the modulator is a current (set by the 200-k Ω integrator input resistor) that makes it possible to have an input voltage greater than the input supplies, as long as the output supply is at least ± 15 V. It is therefore possible, when using an unregulated DC-DC converter, to minimize PSR related output errors with ± 5 -V voltage regulators on the isolated side and still get the full ± 10 -V input and output swing.

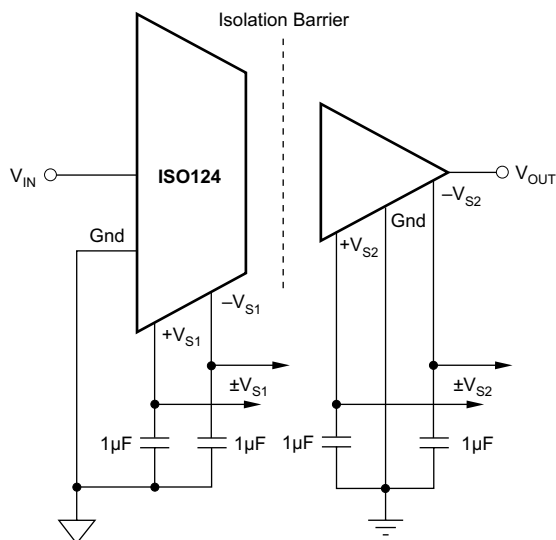

Figure 24. Basic Signal and Power Connections

10 Layout

10.1 Layout Guidelines

To maintain the isolation barrier of the device, the distance between the high-side ground (pin 16 or 28) and the low-side ground (pin 8 or 14) should be kept at maximum; that is, the entire area underneath the device should be kept free of any conducting materials.

10.2 Layout Example

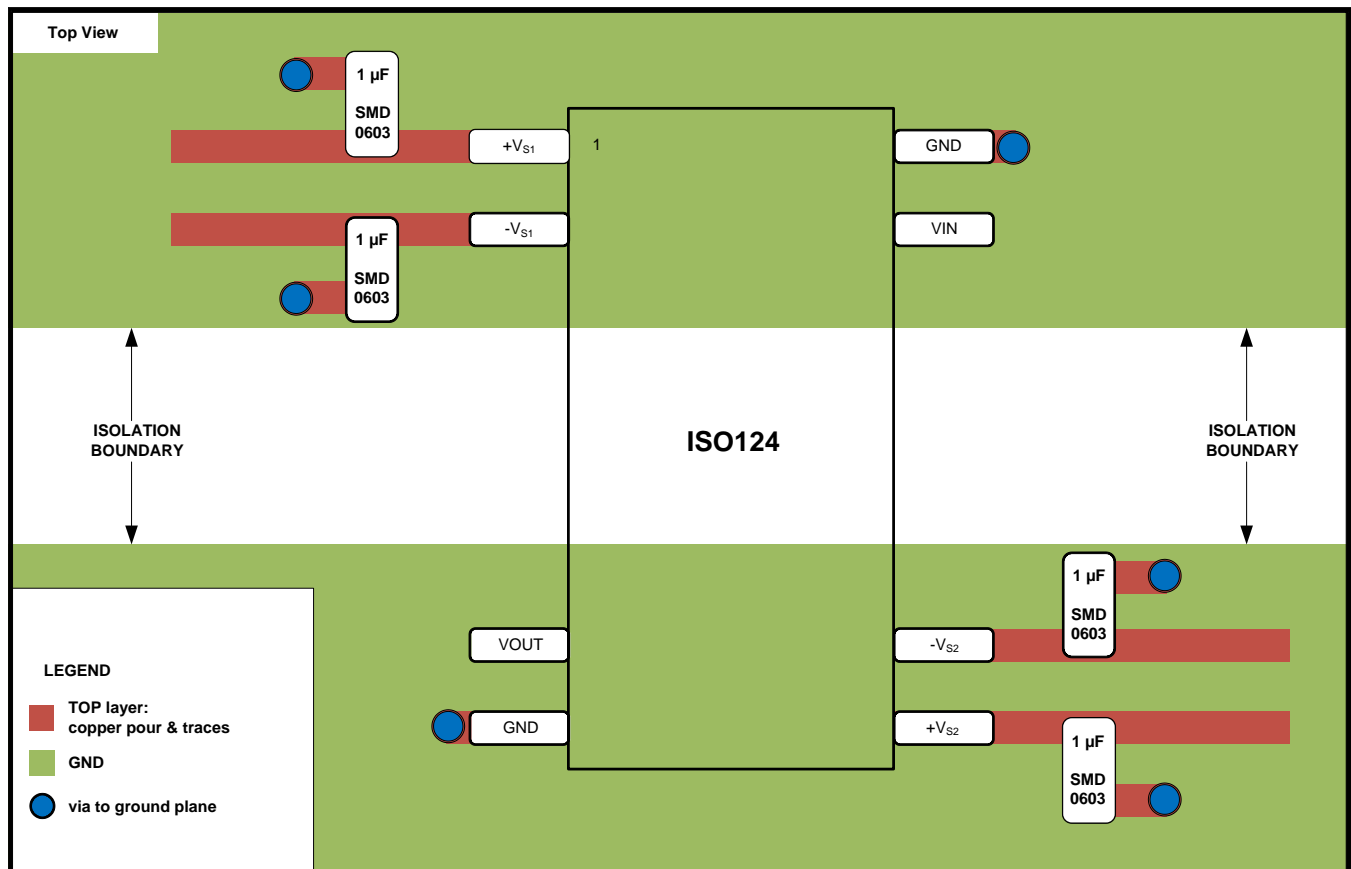

Figure 25. ISO124 Layout Example

11 Device and Documentation Support

11.1 Documentation Support

11.1.1 Related Documentation

For related documentation see the following:

- [Single-Supply Operation of Isolation Amplifiers.](#)
- [Simple Output Filter Eliminates ISO Amp Output Ripple and Keeps Full Bandwidth.](#)
- [FilterPro™ User's Guide.](#)

11.2 Receiving Notification of Documentation Updates

To receive notification of documentation updates, navigate to the device product folder on ti.com. In the upper right corner, click on *Alert me* to register and receive a weekly digest of any product information that has changed. For change details, review the revision history included in any revised document.

11.3 Community Resources

The following links connect to TI community resources. Linked contents are provided "AS IS" by the respective contributors. They do not constitute TI specifications and do not necessarily reflect TI's views; see TI's [Terms of Use](#).

TI E2E™ Online Community *TI's Engineer-to-Engineer (E2E) Community.* Created to foster collaboration among engineers. At e2e.ti.com, you can ask questions, share knowledge, explore ideas and help solve problems with fellow engineers.

Design Support *TI's Design Support* Quickly find helpful E2E forums along with design support tools and contact information for technical support.

11.4 Trademarks

FilterPro, E2E are trademarks of Texas Instruments.
All other trademarks are the property of their respective owners.

11.5 Electrostatic Discharge Caution



This integrated circuit can be damaged by ESD. Texas Instruments recommends that all integrated circuits be handled with appropriate precautions. Failure to observe proper handling and installation procedures can cause damage.

ESD damage can range from subtle performance degradation to complete device failure. Precision integrated circuits may be more susceptible to damage because very small parametric changes could cause the device not to meet its published specifications.

11.6 Glossary

SLYZ022 — *TI Glossary.*

This glossary lists and explains terms, acronyms, and definitions.

12 Mechanical, Packaging, and Orderable Information

The following pages include mechanical, packaging, and orderable information. This information is the most current data available for the designated devices. This data is subject to change without notice and revision of this document. For browser-based versions of this data sheet, refer to the left-hand navigation.

PACKAGING INFORMATION

Orderable Device	Status (1)	Package Type	Package Drawing	Pins	Package Qty	Eco Plan (2)	Lead finish/ Ball material (6)	MSL Peak Temp (3)	Op Temp (°C)	Device Marking (4/5)	Samples
ISO124P	ACTIVE	PDIP	NVF	8	25	RoHS & Non-Green	NIPDAU	N / A for Pkg Type	-25 to 85	ISO124P	Samples
ISO124U	ACTIVE	SOIC	DVA	8	20	RoHS & Green	NIPDAU	Level-3-260C-168 HR	-25 to 85	ISO 124U	Samples
ISO124U/1K	ACTIVE	SOIC	DVA	8	1000	RoHS & Green	NIPDAU	Level-3-260C-168 HR	-25 to 85	ISO 124U	Samples
ISO124U/1KE4	ACTIVE	SOIC	DVA	8	1000	RoHS & Green	NIPDAU	Level-3-260C-168 HR	-25 to 85	ISO 124U	Samples
ISO124UE4	ACTIVE	SOIC	DVA	8	20	RoHS & Green	NIPDAU	Level-3-260C-168 HR	-25 to 85	ISO 124U	Samples

(1) The marketing status values are defined as follows:

ACTIVE: Product device recommended for new designs.

LIFEBUY: TI has announced that the device will be discontinued, and a lifetime-buy period is in effect.

NRND: Not recommended for new designs. Device is in production to support existing customers, but TI does not recommend using this part in a new design.

PREVIEW: Device has been announced but is not in production. Samples may or may not be available.

OBSOLETE: TI has discontinued the production of the device.

(2) **RoHS:** TI defines "RoHS" to mean semiconductor products that are compliant with the current EU RoHS requirements for all 10 RoHS substances, including the requirement that RoHS substance do not exceed 0.1% by weight in homogeneous materials. Where designed to be soldered at high temperatures, "RoHS" products are suitable for use in specified lead-free processes. TI may reference these types of products as "Pb-Free".

RoHS Exempt: TI defines "RoHS Exempt" to mean products that contain lead but are compliant with EU RoHS pursuant to a specific EU RoHS exemption.

Green: TI defines "Green" to mean the content of Chlorine (Cl) and Bromine (Br) based flame retardants meet JS709B low halogen requirements of <=1000ppm threshold. Antimony trioxide based flame retardants must also meet the <=1000ppm threshold requirement.

(3) MSL, Peak Temp. - The Moisture Sensitivity Level rating according to the JEDEC industry standard classifications, and peak solder temperature.

(4) There may be additional marking, which relates to the logo, the lot trace code information, or the environmental category on the device.

(5) Multiple Device Markings will be inside parentheses. Only one Device Marking contained in parentheses and separated by a "~" will appear on a device. If a line is indented then it is a continuation of the previous line and the two combined represent the entire Device Marking for that device.

(6) Lead finish/Ball material - Orderable Devices may have multiple material finish options. Finish options are separated by a vertical ruled line. Lead finish/Ball material values may wrap to two lines if the finish value exceeds the maximum column width.

Important Information and Disclaimer: The information provided on this page represents TI's knowledge and belief as of the date that it is provided. TI bases its knowledge and belief on information provided by third parties, and makes no representation or warranty as to the accuracy of such information. Efforts are underway to better integrate information from third parties. TI has taken and continues to take reasonable steps to provide representative and accurate information but may not have conducted destructive testing or chemical analysis on incoming materials and chemicals. TI and TI suppliers consider certain information to be proprietary, and thus CAS numbers and other limited information may not be available for release.

In no event shall TI's liability arising out of such information exceed the total purchase price of the TI part(s) at issue in this document sold by TI to Customer on an annual basis.

TAPE AND REEL INFORMATION

QUADRANT ASSIGNMENTS FOR PIN 1 ORIENTATION IN TAPE

*All dimensions are nominal

Device	Package Type	Package Drawing	Pins	SPQ	Reel Diameter (mm)	Reel Width W1 (mm)	A0 (mm)	B0 (mm)	K0 (mm)	P1 (mm)	W (mm)	Pin1 Quadrant
ISO124U/1K	SOIC	DVA	8	1000	330.0	24.4	10.9	18.3	3.2	12.0	24.0	Q1

TAPE AND REEL BOX DIMENSIONS

*All dimensions are nominal

Device	Package Type	Package Drawing	Pins	SPQ	Length (mm)	Width (mm)	Height (mm)
ISO124U/1K	SOIC	DVA	8	1000	367.0	367.0	45.0

TUBE

*All dimensions are nominal

Device	Package Name	Package Type	Pins	SPQ	L (mm)	W (mm)	T (μm)	B (mm)
ISO124P	NVF	PDIP	8	25	506	13.97	11230	4.32
ISO124U	DVA	SOIC	8	20	507	12.83	5080	6.6
ISO124UE4	DVA	SOIC	8	20	507	12.83	5080	6.6

NVF (R-PDIP-T8/16)

PLASTIC DUAL-IN-LINE

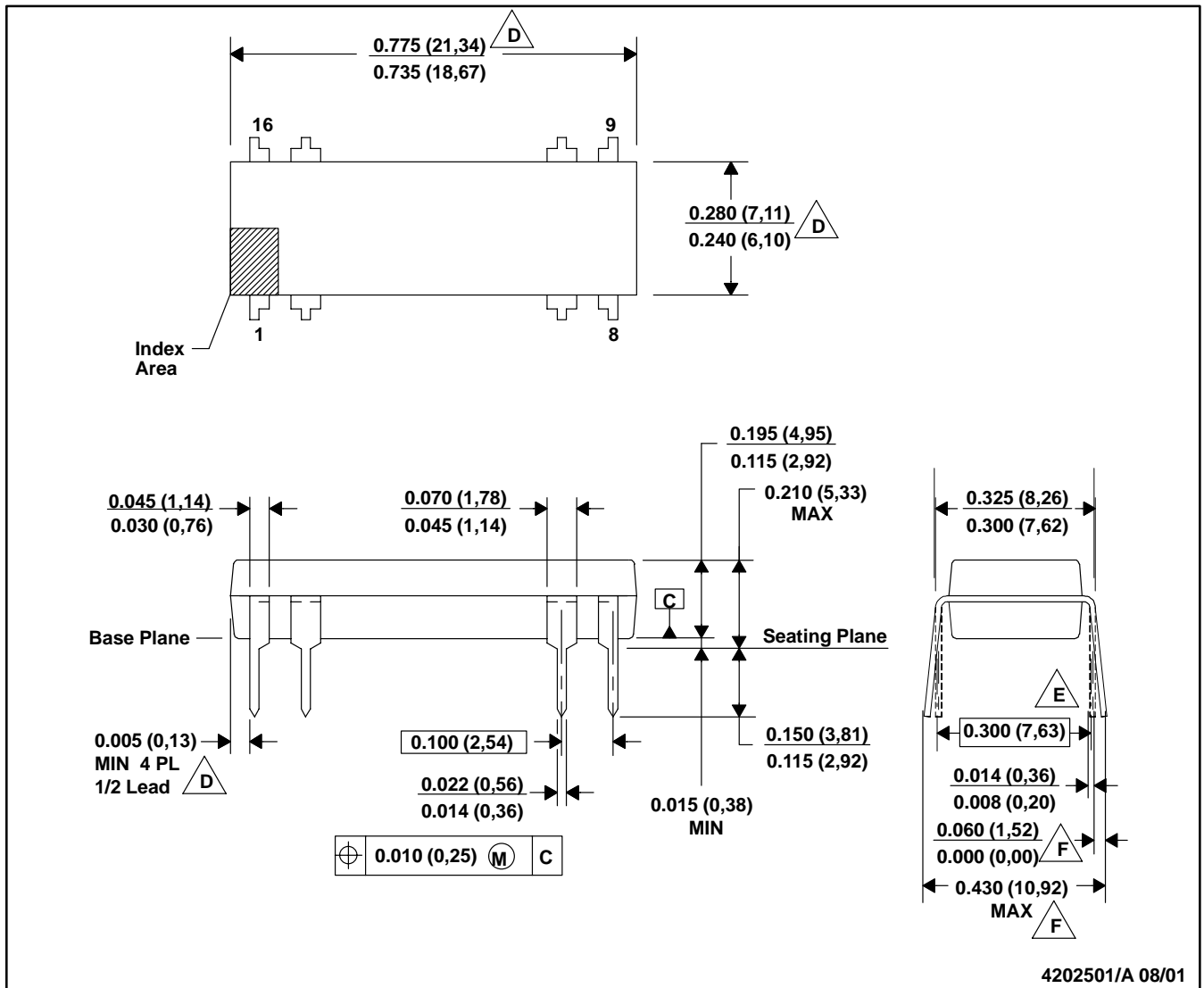

- A. All linear dimensions are in inches (millimeters).
- B. This drawing is subject to change without notice.
- C. Falls within JEDEC MS-001-BB with the exception of lead count.
- $\triangle D$. Dimensions do not include mold flash or protrusions. Mold flash or protrusions shall not exceed 0.010 (0,25).
- $\triangle E$. Dimensions measured with the leads constrained to be perpendicular to Datum C.
- $\triangle F$. Dimensions are measured at the lead tips with the leads unconstrained.
- G. A visual index feature must be located within the cross-hatched area.

DVA (R-PDSO-G8/28)

PLASTIC SMALL-OUTLINE

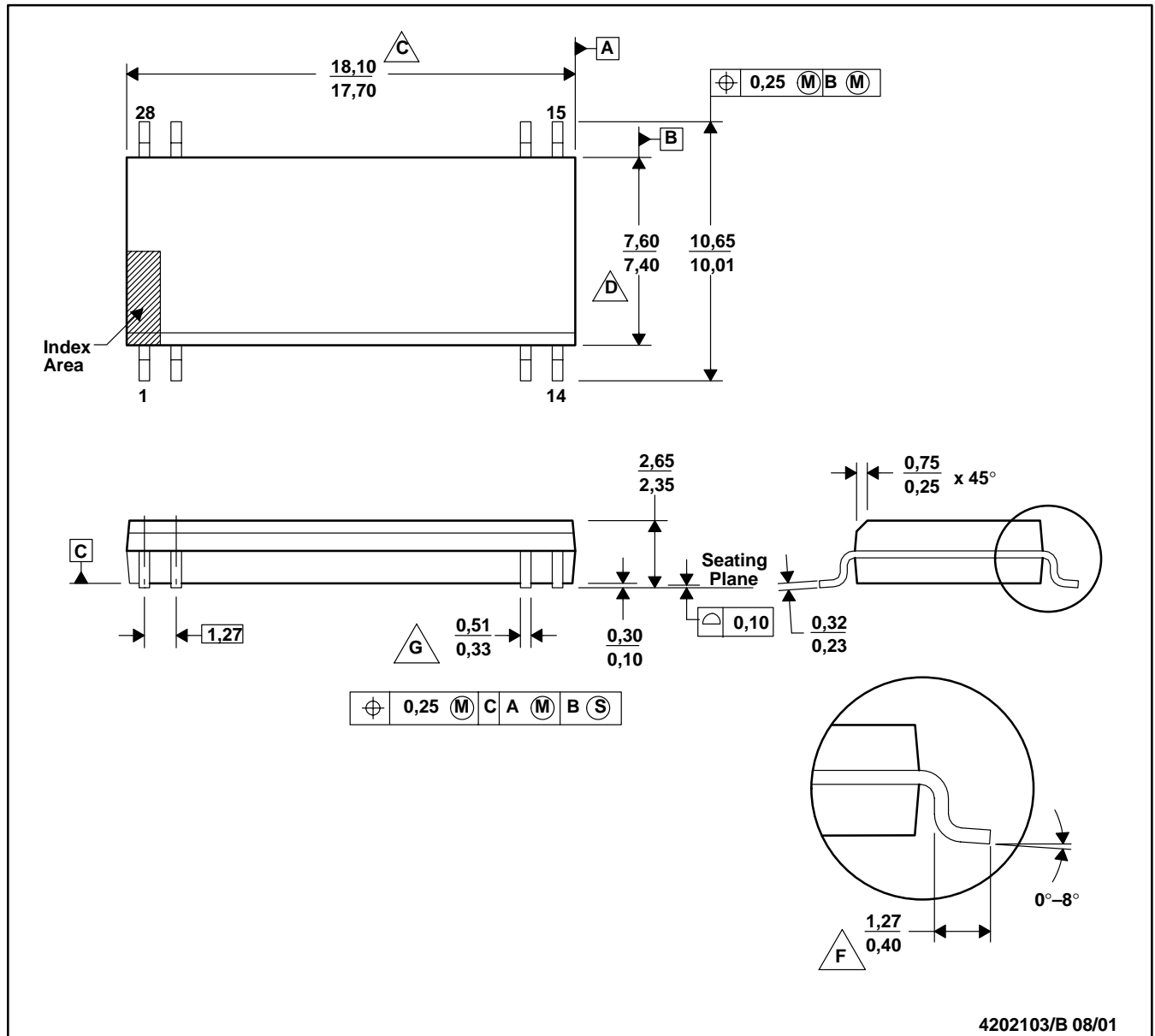

NOTES: A. All linear dimensions are in millimeters.

B. This drawing is subject to change without notice.

C. Body length dimension does not include mold flash, protrusions, or gate burrs. Mold flash, protrusions, and gate burrs shall not exceed 0,15 mm per side.

D. Body width dimension does not include inter-lead flash or protrusions. Inter-lead flash and protrusions shall not exceed 0,25 mm per side.

E. The chamfer on the body is optional. If it is not present, a visual index feature must be located within the cross-hatched area.

F. Lead dimension is the length of terminal for soldering to a substrate.

G. Lead width, as measured 0,36 mm or greater above the seating plane, shall not exceed a maximum value of 0,61 mm.

H. Lead-to-lead coplanarity shall be less than 0,10 mm from seating plane.

I. Falls within JEDEC MS-013-AE with the exception of the number of leads.

IMPORTANT NOTICE AND DISCLAIMER

TI PROVIDES TECHNICAL AND RELIABILITY DATA (INCLUDING DATA SHEETS), DESIGN RESOURCES (INCLUDING REFERENCE DESIGNS), APPLICATION OR OTHER DESIGN ADVICE, WEB TOOLS, SAFETY INFORMATION, AND OTHER RESOURCES "AS IS" AND WITH ALL FAULTS, AND DISCLAIMS ALL WARRANTIES, EXPRESS AND IMPLIED, INCLUDING WITHOUT LIMITATION ANY IMPLIED WARRANTIES OF MERCHANTABILITY, FITNESS FOR A PARTICULAR PURPOSE OR NON-INFRINGEMENT OF THIRD PARTY INTELLECTUAL PROPERTY RIGHTS.

These resources are intended for skilled developers designing with TI products. You are solely responsible for (1) selecting the appropriate TI products for your application, (2) designing, validating and testing your application, and (3) ensuring your application meets applicable standards, and any other safety, security, regulatory or other requirements.

These resources are subject to change without notice. TI grants you permission to use these resources only for development of an application that uses the TI products described in the resource. Other reproduction and display of these resources is prohibited. No license is granted to any other TI intellectual property right or to any third party intellectual property right. TI disclaims responsibility for, and you will fully indemnify TI and its representatives against, any claims, damages, costs, losses, and liabilities arising out of your use of these resources.



TI's products are provided subject to [TI's Terms of Sale](#) or other applicable terms available either on ti.com or provided in conjunction with such TI products. TI's provision of these resources does not expand or otherwise alter TI's applicable warranties or warranty disclaimers for TI products.

TI objects to and rejects any additional or different terms you may have proposed.

Mailing Address: Texas Instruments, Post Office Box 655303, Dallas, Texas 75265
Copyright © 2022, Texas Instruments Incorporated

Looking for pricing, stock, or lifecycle information?

Click below to explore more details on WIN SOURCE:

-  [View ISO124U](#) on WIN SOURCE
-  [Texas Instruments](#) Information

Optimize Your Supply Chain with WIN SOURCE Solutions

-  Global Sourcing Solution
-  Obsolete Management
-  Cost Control Management
-  Shortage Management
-  Alternative Solution
-  Excess Inventory Management