

BQ34Z100-R2 Wide Range Fuel Gauge with Impedance Track™ Technology

1 Features

- Supports Li-ion, LiFePO₄, PbA, NiMH, and NiCd chemistries
- Capacity estimation using patented Impedance Track™ technology for batteries from 3 V to 16.7 KV
 - Aging compensation
 - Self-discharge compensation
- Supports battery capacities up to 7000 Ah with standard configuration options
- Supports charge and discharge currents up to 8160 A with standard configuration options
- External NTC thermistor support
- Supports two-wire I²C and HDQ single-wire communication interfaces with host system
- SHA-1/HMAC authentication
- One- or four-LED direct display control
- Five-LED and higher display through port expander
- Reduced power modes (typical battery pack operating range conditions)
 - NORMAL operation: < 145-μA average
 - SLEEP: < 84-μA average
 - FULL SLEEP: < 30-μA average
- Package: 14-pin TSSOP

2 Applications

- [Light electric vehicles](#)
- [Medical instrumentation](#)
- [Mobile radios](#)
- [Power tools](#)
- [Uninterruptible power supplies \(UPS\)](#)

3 Description

The BQ34Z100-R2 device is an Impedance Track™ fuel gauge for Li-ion, PbA, NiMH, and NiCd batteries, and works independently of battery series-cell configurations. Batteries from 3 V to 16.7 KV can be easily supported through an external voltage translation circuit that is controlled automatically to reduce system power consumption.

The BQ34Z100-R2 device provides several interface options, including an I²C peripheral, an HDQ peripheral, one or four direct LEDs, and an ALERT output pin. Additionally, the BQ34Z100-R2 provides support for an external port expander for more than four LEDs.

Device Information

PART NUMBER ⁽¹⁾	PACKAGE	BODY SIZE (NOM)
BQ34Z100-R2	TSSOP (14)	5.00 mm × 4.40 mm

(1) For all available packages, see the orderable addendum at the end of the data sheet.

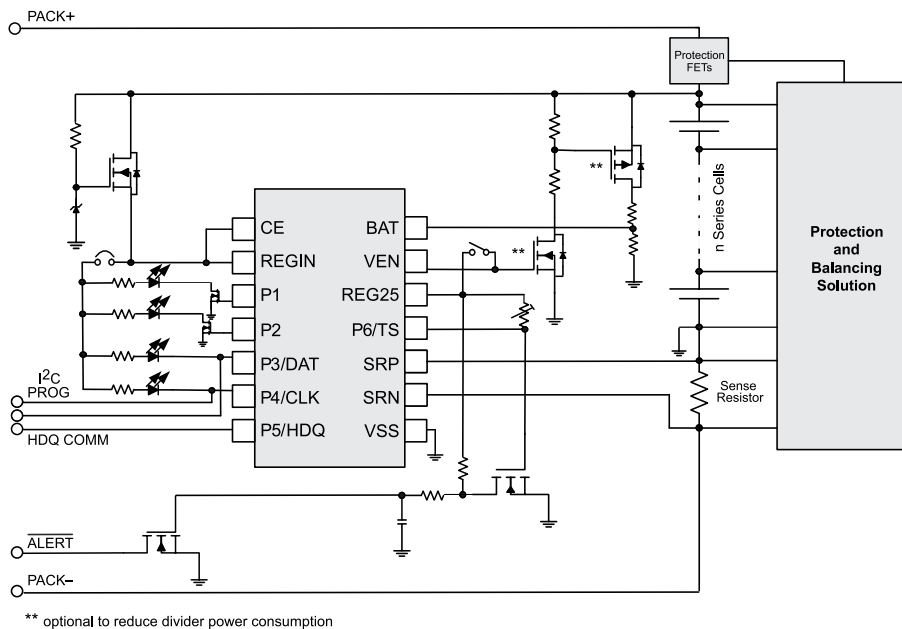

Simplified Schematic



Table of Contents

1 Features	1	6.12 Electrical Characteristics: Data Flash Memory Characteristics.....	7
2 Applications	1	6.13 Timing Requirements: HDQ Communication.....	7
3 Description	1	6.14 Timing Requirements: I ² C-Compatible Interface.....	8
4 Revision History	2	6.15 Typical Characteristics.....	9
5 Pin Configuration and Functions	3	7 Functional Block Diagram	10
6 Specifications	4	8 Application and Implementation	11
6.1 Absolute Maximum Ratings.....	4	8.1 Application Information.....	11
6.2 ESD Ratings.....	4	8.2 Typical Applications.....	11
6.3 Recommended Operating Conditions.....	4	9 Power Supply Recommendations	17
6.4 Thermal Information.....	5	10 Layout	18
6.5 Electrical Characteristics: Power-On Reset.....	5	10.1 Layout Guidelines.....	18
6.6 Electrical Characteristics: LDO Regulator.....	5	10.2 Layout Example.....	18
6.7 Electrical Characteristics: Internal Temperature Sensor Characteristics.....	5	11 Device and Documentation Support	21
6.8 Electrical Characteristics: Low-Frequency Oscillator.....	6	11.1 Documentation Support.....	21
6.9 Electrical Characteristics: High-Frequency Oscillator.....	6	11.2 Receiving Notification of Documentation Updates..	21
6.10 Electrical Characteristics: Integrating ADC (Coulomb Counter) Characteristics.....	6	11.3 Support Resources.....	21
6.11 Electrical Characteristics: ADC (Temperature and Cell Measurement) Characteristics.....	6	11.4 Trademarks.....	21
		11.5 Electrostatic Discharge Caution.....	21
		11.6 Glossary.....	21
		12 Mechanical, Packaging, and Orderable Information	21

4 Revision History

NOTE: Page numbers for previous revisions may differ from page numbers in the current version.

DATE	REVISION	NOTES
December 2022	*	Initial Release

5 Pin Configuration and Functions

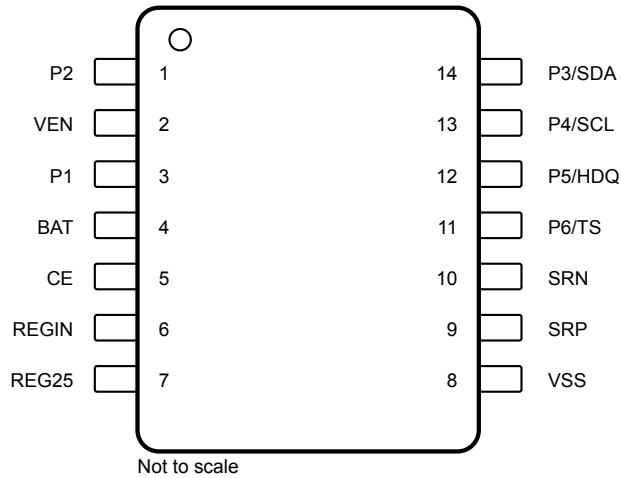

Table 5-1. Pin Functions

PIN		TYPE	DESCRIPTION
NAME	NUMBER		
P2	1	O	LED 2 or Not Used (connect to VSS)
VEN	2	O	Active High Voltage Translation Enable. This signal is optionally used to switch the input voltage divider on/off to reduce the power consumption (typ 45 μ A) of the divider network. If not used, then this pin can be left floating or tied to VSS.
P1	3	O	LED 1 or Not Used (connect to VSS). This pin is also used to drive an LED for single-LED mode. Use a small signal N-FET (Q1) in series with the LED as shown on Figure 8-4 .
BAT	4	I	Translated Battery Voltage Input
CE	5	I	Chip Enable. Internal LDO is disconnected from REGIN when driven low.
REGIN	6	P	Internal integrated LDO input. Decouple with a 0.1- μ F ceramic capacitor to VSS.
REG25	7	P	2.5-V output voltage of the internal integrated LDO. Decouple with 1- μ F ceramic capacitor to VSS.
VSS	8	P	Device ground
SRP	9	I	Analog input pin connected to the internal coulomb-counter peripheral for integrating a small voltage between SRP and SRN where SRP is nearest the BAT– connection.
SRN	10	I	Analog input pin connected to the internal coulomb-counter peripheral for integrating a small voltage between SRP and SRN where SRN is nearest the PACK– connection.
P6/TS	11	I	Pack thermistor voltage sense (use a 103AT-type thermistor)
P5/HDQ	12	I/O	Open-drain HDQ Serial communication line (target). If not used, then this pin can be left floating or tied to VSS.
P4/SCL	13	I	Target I ² C serial communication clock input. Use with a 10-k Ω pullup resistor (typical). This pin is also used for LED 4 in the four-LED mode. If not used, then this pin can be left floating or tied to VSS.
P3/SDA	14	I/O	Open-drain target I ² C serial communication data line. Use with a 10-k Ω pullup resistor (typical). This pin is also used for LED 3 in the four-LED mode. If not used, then this pin can be left floating or tied to VSS.

6 Specifications

6.1 Absolute Maximum Ratings

Over operating free-air temperature range (unless otherwise noted)⁽¹⁾

		MIN	MAX	UNIT
V _{REGIN}	Regulator Input Range	-0.3	5.5	V
V _{CC}	Supply Voltage Range	-0.3	2.75	V
V _{IOD}	Open-drain I/O pins (SDA, SCL, HDQ, VEN)	-0.3	5.5	V
V _{BAT}	Bat Input pin	-0.3	5.5	V
V _I	Input Voltage range to all other pins (P1, P2, SRP, SRN)	-0.3	V _{CC} + 0.3	V
ESD	Human-body model (HBM), BAT pin		1.5	kV
	Human-body model (HBM), all other pins		2	kV
T _A	Operating free-air temperature range	-40	85	°C
T _F	Functional temperature range	-40	100	°C
T _{STG}	Storage temperature range	-65	150	°C
	Lead temperature (soldering, 10 s)	-40	100	°C

- (1) Operation outside the Absolute Maximum Ratings may cause permanent device damage. Absolute Maximum Ratings do not imply functional operation of the device at these or any other conditions beyond those listed under Recommended Operating Conditions. If outside the Recommended Operating Conditions but within the Absolute Maximum Ratings, the device may not be fully functional, and this may affect device reliability, functionality, performance, and shorten the device lifetime.

6.2 ESD Ratings

		VALUE	UNIT
V _(ESD)	Electrostatic discharge	Human body model (HBM), per ANSI/ESDA/JEDEC JS-001 ⁽¹⁾	±2000
		Charged device model (CDM), per ANSI/ESDA/JEDEC JS-002 ⁽²⁾	±500

- (1) JEDEC document JEP155 states that 500-V HBM allows safe manufacturing with a standard ESD control process.
(2) JEDEC document JEP157 states that 250-V CDM allows safe manufacturing with a standard ESD control process.

6.3 Recommended Operating Conditions

T_A = -40°C to 85°C; Typical Values at T_A = 25°C C_{LDO25} = 1.0 µF, and V_{REGIN} = 3.6 V (unless otherwise noted)

			MIN	NOM	MAX	UNIT
V _{REGIN}	Supply Voltage	No operating restrictions		2.7	4.5	V
		No FLASH writes		2.45	2.7	V
C _{REGIN}	External input capacitor for internal LDO between REGIN and VSS	Nominal capacitor values specified. Recommend a 10% ceramic X5R type capacitor located close to the device.		0.1		µF
C _{LDO25}	External output capacitor for internal LDO between VCC and VSS		0.47	1		µF
I _{CC}	NORMAL operating-mode current	Gas Gauge in NORMAL mode, I _{LOAD} > Sleep Current		145		µA
I _{SLP}	SLEEP operating-mode current	Gas Gauge in SLEEP mode, I _{LOAD} < Sleep Current		84		µA
I _{SLP+}	FULLSLEEP operating-mode current	Gas Gauge in FULL SLEEP mode, I _{LOAD} < Sleep Current		30		µA
V _{OL}	Output voltage, low (SCL, SDA, HDQ, VEN)	I _{OL} = 3 mA			0.4	V
V _{OH(PP)}	Output voltage, high	I _{OH} = -1 mA	V _{CC} - 0.5			V
V _{OH(OD)}	Output voltage, high (SDA, SCL, HDQ, VEN)	External pull-up resistor connected to V _{CC}	V _{CC} - 0.5			V
V _{IL}	Input voltage, low		-0.3		0.6	V

6.3 Recommended Operating Conditions (continued)

$T_A = -40^\circ\text{C}$ to 85°C ; Typical Values at $T_A = 25^\circ\text{C}$ $C_{LDO25} = 1.0\ \mu\text{F}$, and $V_{\text{REGIN}} = 3.6\ \text{V}$ (unless otherwise noted)

		MIN	NOM	MAX	UNIT
$V_{\text{IH(OD)}}$	Input voltage, high (SDA, SCL, HDQ)	1.2		6	V
V_{A1}	Input voltage range (TS)	$V_{\text{SS}} - 0.05$		1	V
V_{A2}	Input voltage range (BAT)	$V_{\text{SS}} - 0.125$		5	V
V_{A3}	Input voltage range (SRP, SRN)	$V_{\text{SS}} - 0.125$		0.125	V
I_{LKG}	Input leakage current (I/O pins)			0.3	μA
t_{PUCD}	Power-up communication delay		250		ms

6.4 Thermal Information

THERMAL METRIC ⁽¹⁾		BQ34Z100-R2			UNIT
		TSSOP (PW)			
		14 PINS			
$R_{\theta\text{JA, High K}}$	Junction-to-ambient thermal resistance	103.8			$^\circ\text{C}/\text{W}$
$R_{\theta\text{JC(top)}}$	Junction-to-case(top) thermal resistance	31.9			
$R_{\theta\text{JB}}$	Junction-to-board thermal resistance	46.6			
Ψ_{JT}	Junction-to-top characterization parameter	2.0			
Ψ_{JB}	Junction-to-board characterization parameter	45.9			
$R_{\theta\text{JC(bottom)}}$	Junction-to-case(bottom) thermal resistance	N/A			

(1) For more information about traditional and new thermal metrics, see the *Semiconductor and IC Package Thermal Metrics Application Report*, [SPRA953](#).

6.5 Electrical Characteristics: Power-On Reset

$T_A = -40^\circ\text{C}$ to 85°C ; Typical Values at $T_A = 25^\circ\text{C}$ and $V_{\text{REGIN}} = 3.6\ \text{V}$ (unless otherwise noted)

PARAMETER	TEST CONDITIONS	MIN	TYP	MAX	UNIT
$V_{\text{IT+}}$	Positive-going battery voltage input at REG25	2.05	2.20	2.31	V
V_{HYS}	Power-on reset hysteresis	45	115	185	mV

6.6 Electrical Characteristics: LDO Regulator

$T_A = 25^\circ\text{C}$, $C_{LDO25} = 1.0\ \mu\text{F}$, $V_{\text{REGIN}} = 3.6\ \text{V}$ (unless otherwise noted)⁽¹⁾

PARAMETER	TEST CONDITIONS		MIN	TYP	MAX	UNIT	
V_{REG25}	Regulator output voltage	$2.7\ \text{V} \leq V_{\text{REGIN}} \leq 4.5\ \text{V}$, $I_{\text{OUT}} \leq 16\ \text{mA}$	$T_A = -40^\circ\text{C}$ to 85°C	2.3	2.5	2.7	V
		$2.45\ \text{V} \leq V_{\text{REGIN}} < 2.7\ \text{V}$ (low battery), $I_{\text{OUT}} \leq 3\ \text{mA}$	$T_A = -40^\circ\text{C}$ to 85°C	2.3			
$I_{\text{SHORT}}^{(2)}$	Short Circuit Current Limit	$V_{\text{REG25}} = 0\ \text{V}$	$T_A = -40^\circ\text{C}$ to 85°C		250	mA	

(1) LDO output current, I_{OUT} , is the sum of internal and external load currents.

(2) Specified by design. Not production tested.

6.7 Electrical Characteristics: Internal Temperature Sensor Characteristics

$T_A = -40^\circ\text{C}$ to 85°C , $2.4\ \text{V} < \text{REG25} < 2.6\ \text{V}$; Typical Values at $T_A = 25^\circ\text{C}$ and $\text{REG25} = 2.5\ \text{V}$ (unless otherwise noted)

PARAMETER	TEST CONDITIONS	MIN	TYP	MAX	UNIT
G_{TEMP}	Temperature sensor voltage gain		-2		$\text{mV}/^\circ\text{C}$

6.8 Electrical Characteristics: Low-Frequency Oscillator

$T_A = -40^\circ\text{C}$ to 85°C , $2.4\text{ V} < \text{REG25} < 2.6\text{ V}$; Typical Values at $T_A = 25^\circ\text{C}$ and $\text{REG25} = 2.5\text{ V}$ (unless otherwise noted)

PARAMETER	TEST CONDITIONS	MIN	TYP	MAX	UNIT
$f_{(\text{LOSC})}$	Operating frequency		32.768		kHz
$f_{(\text{LEIO})}$	Frequency error ^{(1) (2)}	$T_A = 0^\circ\text{C}$ to 60°C	-1.5%	0.25%	1.5%
		$T_A = -20^\circ\text{C}$ to 70°C	-2.5%	0.25%	2.5%
		$T_A = -40^\circ\text{C}$ to 85°C	-4%	0.25%	4%
$t_{(\text{LSXO})}$	Start-up time ⁽³⁾		500		μs

(1) The frequency drift is included and measured from the trimmed frequency at $V_{\text{CC}} = 2.5\text{ V}$, $T_A = 25^\circ\text{C}$.

(2) The frequency error is measured from 32.768 kHz.

(3) The startup time is defined as the time it takes for the oscillator output frequency to be $\pm 3\%$.

6.9 Electrical Characteristics: High-Frequency Oscillator

$T_A = -40^\circ\text{C}$ to 85°C , $2.4\text{ V} < \text{REG25} < 2.6\text{ V}$; Typical Values at $T_A = 25^\circ\text{C}$ and $\text{REG25} = 2.5\text{ V}$ (unless otherwise noted)

PARAMETER	TEST CONDITIONS	MIN	TYP	MAX	UNIT
$f_{(\text{OSC})}$	Operating frequency		8.389		MHz
$f_{(\text{EIO})}$	Frequency error ^{(1) (2)}	$T_A = 0^\circ\text{C}$ to 60°C	-2%	0.38%	2%
		$T_A = -20^\circ\text{C}$ to 70°C	-3%	0.38%	3%
		$T_A = -40^\circ\text{C}$ to 85°C	-4.5%	0.38%	4.5%
$t_{(\text{SXO})}$	Start-up time ⁽²⁾		2.5	5	ms

(1) The frequency error is measured from 2.097 MHz.

(2) The startup time is defined as the time it takes for the oscillator output frequency to be $\pm 3\%$.

6.10 Electrical Characteristics: Integrating ADC (Coulomb Counter) Characteristics

$T_A = -40^\circ\text{C}$ to 85°C , $2.4\text{ V} < \text{REG25} < 2.6\text{ V}$; Typical Values at $T_A = 25^\circ\text{C}$ and $\text{REG25} = 2.5\text{ V}$ (unless otherwise noted)

PARAMETER	TEST CONDITIONS	MIN	TYP	MAX	UNIT
$V_{(\text{SR})}$	Input voltage range, $V_{(\text{SRN})}$ and $V_{(\text{SRP})}$	$V_{(\text{SR})} = V_{(\text{SRN})} - V_{(\text{SRP})}$	-0.125	0.125	V
$t_{\text{SR_CONV}}$	Conversion time	Single conversion	1		s
	Resolution		14	15	bits
$V_{\text{OS}(\text{SR})}$	Input offset		10		μV
I_{NL}	Integral nonlinearity error		$\pm 0.007\%$	$\pm 0.034\%$	FSR ⁽²⁾
$Z_{\text{IN}(\text{SR})}$	Effective input resistance ⁽¹⁾		2.5		M Ω
$I_{\text{kg}(\text{SR})}$	Input leakage current ⁽¹⁾			0.3	μA

(1) Specified by design. Not tested in production.

(2) Full-scale reference

6.11 Electrical Characteristics: ADC (Temperature and Cell Measurement) Characteristics

$T_A = -40^\circ\text{C}$ to 85°C , $2.4\text{ V} < \text{REG25} < 2.6\text{ V}$; Typical Values at $T_A = 25^\circ\text{C}$ and $\text{REG25} = 2.5\text{ V}$ (unless otherwise noted)

PARAMETER	TEST CONDITIONS	MIN	TYP	MAX	UNIT
$V_{\text{IN}(\text{ADC})}$	Input voltage range	0.05		1	V
$t_{\text{ADC_CONV}}$	Conversion time			125	ms
	Resolution		14	15	bits
$V_{\text{OS}(\text{ADC})}$	Input offset		1		mV
$Z_{\text{ADC}1}$	Effective input resistance (TS) ⁽¹⁾		8		M Ω
$Z_{\text{ADC}2}$	Effective input resistance (BAT) ⁽¹⁾	BQ34Z100-R2 not measuring cell voltage	8		M Ω
		BQ34Z100-R2 measuring cell voltage		100	K Ω

6.11 Electrical Characteristics: ADC (Temperature and Cell Measurement) Characteristics (continued)

$T_A = -40^\circ\text{C}$ to 85°C , $2.4\text{ V} < \text{REG25} < 2.6\text{ V}$; Typical Values at $T_A = 25^\circ\text{C}$ and $\text{REG25} = 2.5\text{ V}$ (unless otherwise noted)

PARAMETER	TEST CONDITIONS	MIN	TYP	MAX	UNIT
$I_{\text{kg(ADC)}}$	Input leakage current ⁽¹⁾			0.3	μA

(1) Specified by design. Not tested in production.

6.12 Electrical Characteristics: Data Flash Memory Characteristics

$T_A = -40^\circ\text{C}$ to 85°C , $2.4\text{ V} < \text{REG25} < 2.6\text{ V}$; Typical Values at $T_A = 25^\circ\text{C}$ and $\text{REG25} = 2.5\text{ V}$ (unless otherwise noted)

PARAMETER	TEST CONDITIONS	MIN	TYP	MAX	UNIT
t_{DR}	Data retention ⁽¹⁾		10		Years
	Flash-programming write cycles ⁽¹⁾		20,000		Cycles
t_{WORDPROG}	Word programming time ⁽¹⁾			2	ms
I_{CCPROG}	Flash-write supply current ⁽¹⁾		5	10	mA

(1) Specified by design. Not tested in production.

6.13 Timing Requirements: HDQ Communication

$T_A = -40^\circ\text{C}$ to 85°C , $2.45\text{ V} < V_{\text{REGIN}} = V_{\text{BAT}} < 5.5\text{ V}$; typical values at $T_A = 25^\circ\text{C}$ and $V_{\text{REGIN}} = V_{\text{BAT}} = 3.6\text{ V}$ (unless otherwise noted)

PARAMETER	TEST CONDITIONS	MIN	NOM	MAX	UNIT
$t_{\text{(CYCH)}}$	Cycle time, host to BQ34Z100-R2	190			μs
$t_{\text{(CYCD)}}$	Cycle time, BQ34Z100-R2 to host	190	205	250	μs
$t_{\text{(HW1)}}$	Host sends 1 to BQ34Z100-R2	0.5		50	μs
$t_{\text{(DW1)}}$	BQ34Z100-R2 sends 1 to host	32		50	μs
$t_{\text{(HW0)}}$	Host sends 0 to BQ34Z100-R2	86		145	μs
$t_{\text{(DW0)}}$	BQ34Z100-R2 sends 0 to host	80		145	μs
$t_{\text{(RSPS)}}$	Response time, BQ34Z100-R2 to host	190		950	μs
$t_{\text{(B)}}$	Break time	190			μs
$t_{\text{(BR)}}$	Break recovery time	40			μs
$t_{\text{(RISE)}}$	HDQ line rising time to logic 1 (1.2 V)			950	ns
$t_{\text{(RST)}}$	HDQ Reset	1.8		2.2	s

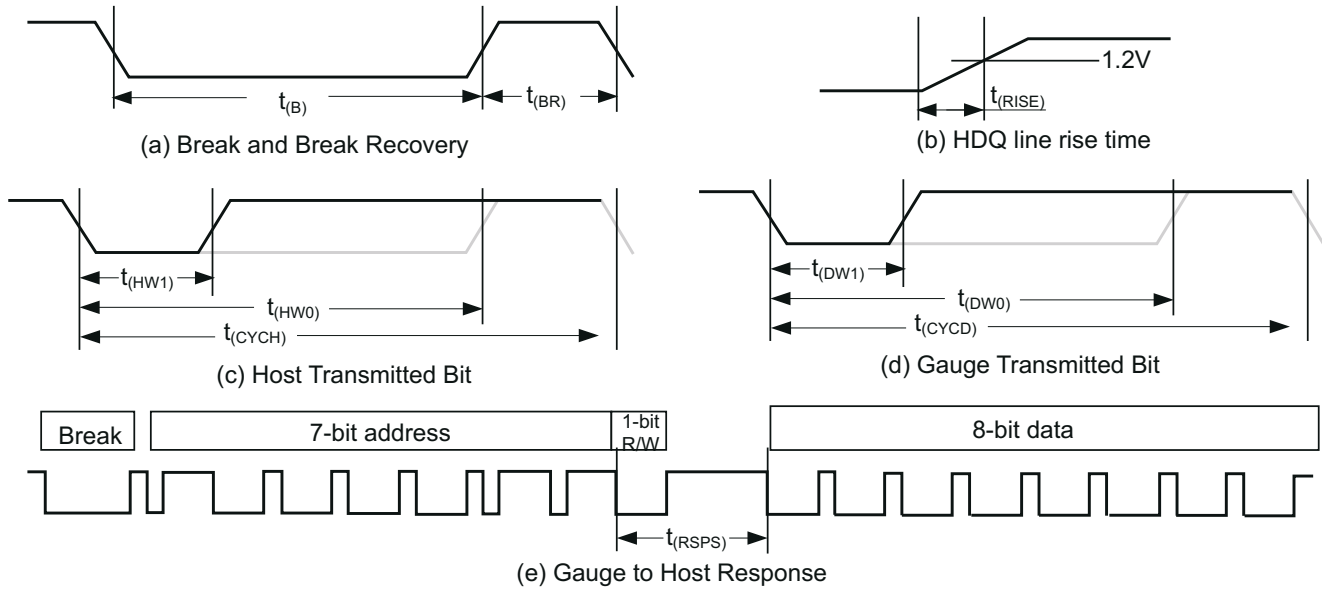

Figure 6-1. Timing Diagrams

6.14 Timing Requirements: I²C-Compatible Interface

$T_A = -40^{\circ}\text{C}$ to 85°C , $2.45\text{ V} < V_{\text{REGIN}} = V_{\text{BAT}} < 5.5\text{ V}$; typical values at $T_A = 25^{\circ}\text{C}$ and $V_{\text{REGIN}} = V_{\text{BAT}} = 3.6\text{ V}$ (unless otherwise noted)

PARAMETER		TEST CONDITIONS	MIN	NOM	MAX	UNIT
t_r	SCL/SDA rise time				300	ns
t_f	SCL/SDA fall time				300	ns
$t_{w(H)}$	SCL pulse width (high)		600			ns
$t_{w(L)}$	SCL pulse width (low)		1.3			μs
$t_{\text{su(STA)}}$	Setup for repeated start		600			ns
$t_{\text{d(STA)}}$	Start to first falling edge of SCL		600			ns
$t_{\text{su(DAT)}}$	Data setup time		100			ns
$t_{\text{h(DAT)}}$	Data hold time		0			ns
$t_{\text{su(STOP)}}$	Setup time for stop		600			ns
t_{BUF}	Bus free time between stop and start		66			μs
f_{SCL}	Clock frequency				400	kHz

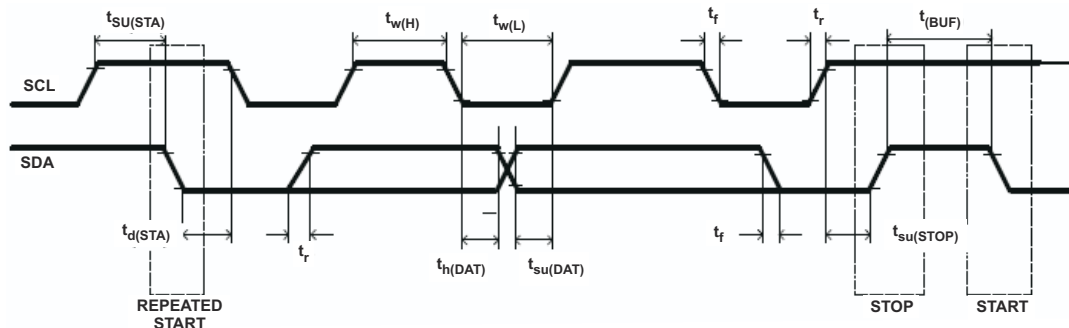
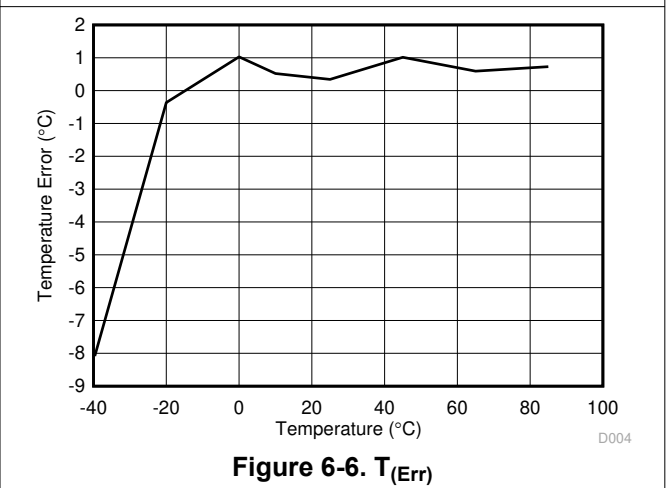
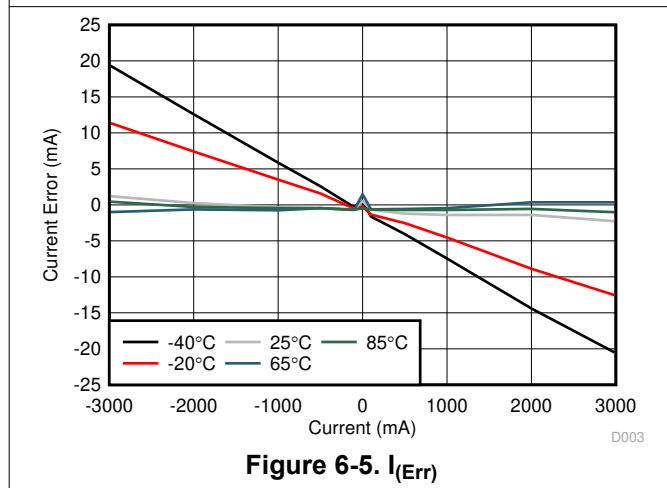
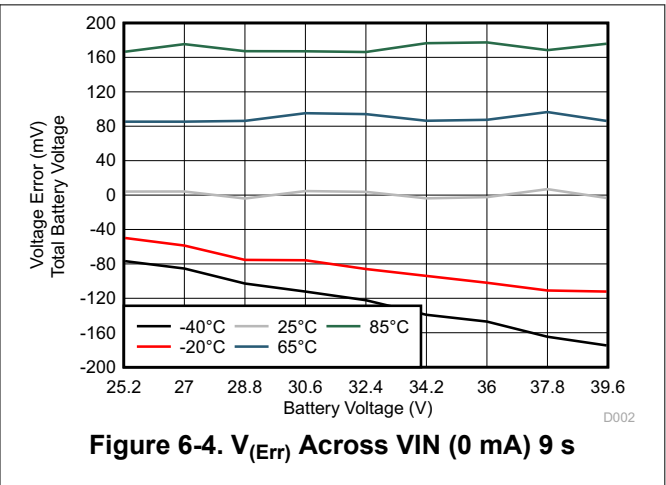
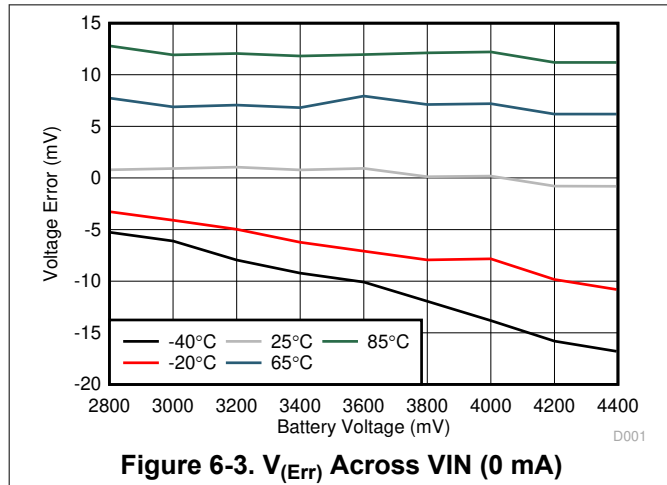
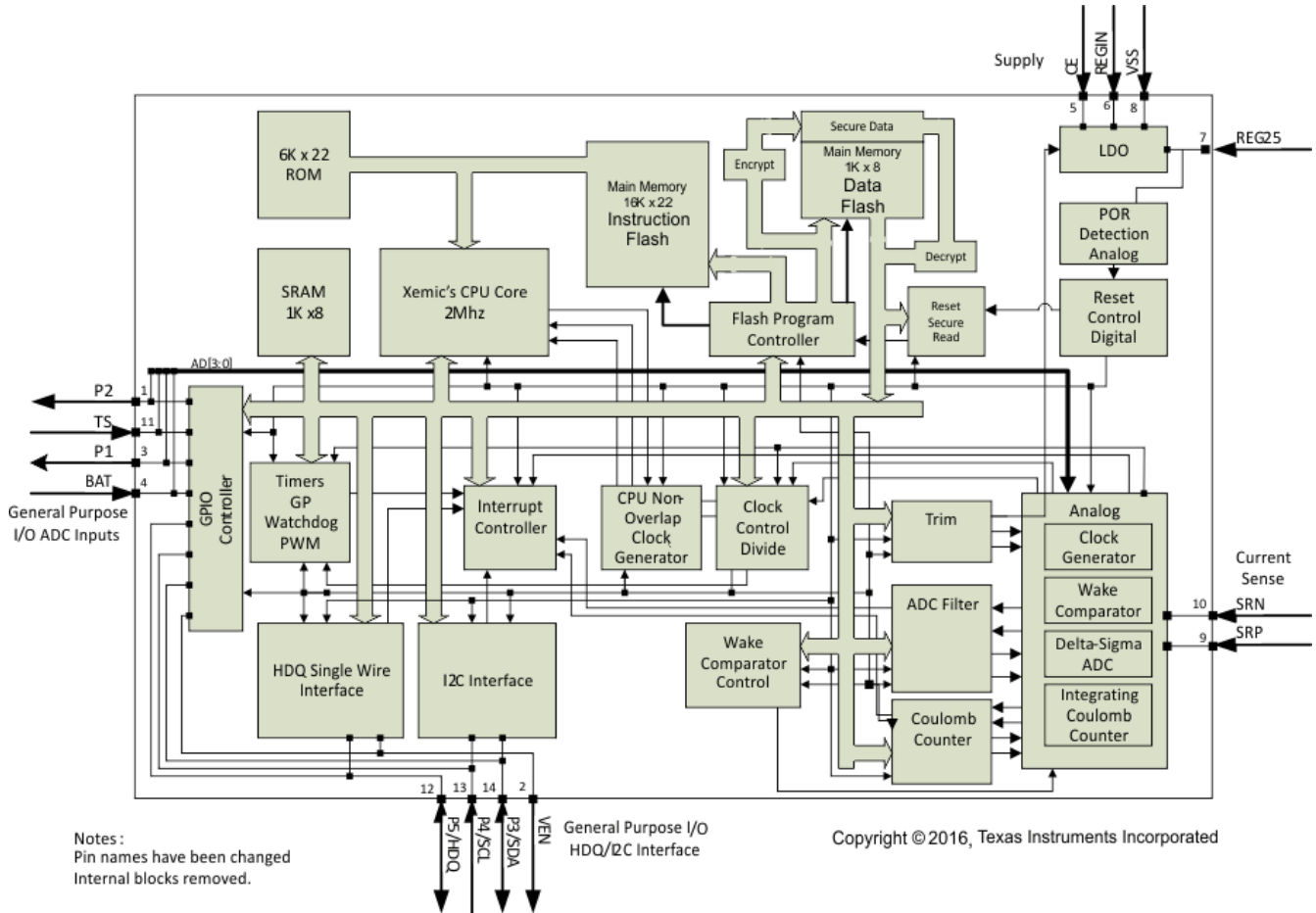

Figure 6-2. I²C-Compatible Interface Timing Diagrams

6.15 Typical Characteristics



7 Functional Block Diagram



8 Application and Implementation

Note

Information in the following applications sections is not part of the TI component specification, and TI does not warrant its accuracy or completeness. TI's customers are responsible for determining suitability of components for their purposes, as well as validating and testing their design implementation to confirm system functionality.

8.1 Application Information

The BQ34Z100-R2 is a flexible gas gauge device with many options. The major configuration choices comprise the battery chemistry, digital interface, and display.

8.2 Typical Applications

Figure 8-1 is a simplified diagram of the main features of the BQ34Z100-R2. Specific implementations detailing the main configuration options are shown later in this section.

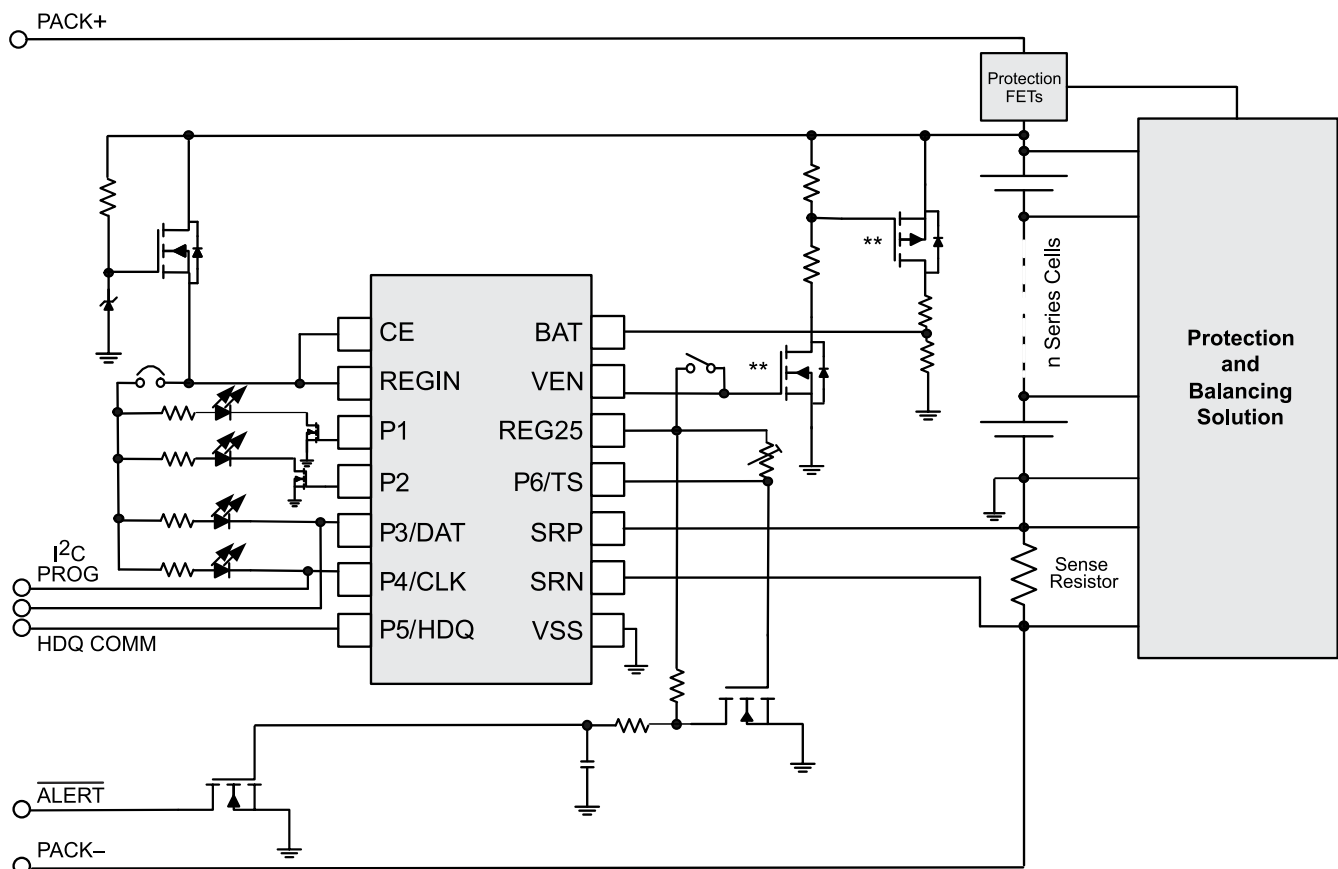

** optional to reduce divider power consumption

Figure 8-1. BQ34Z100-R2 Simplified Implementation

The BQ34Z100-R2 can be used to provide a single Li-ion cell gas gauge with a 5-bar LED display.

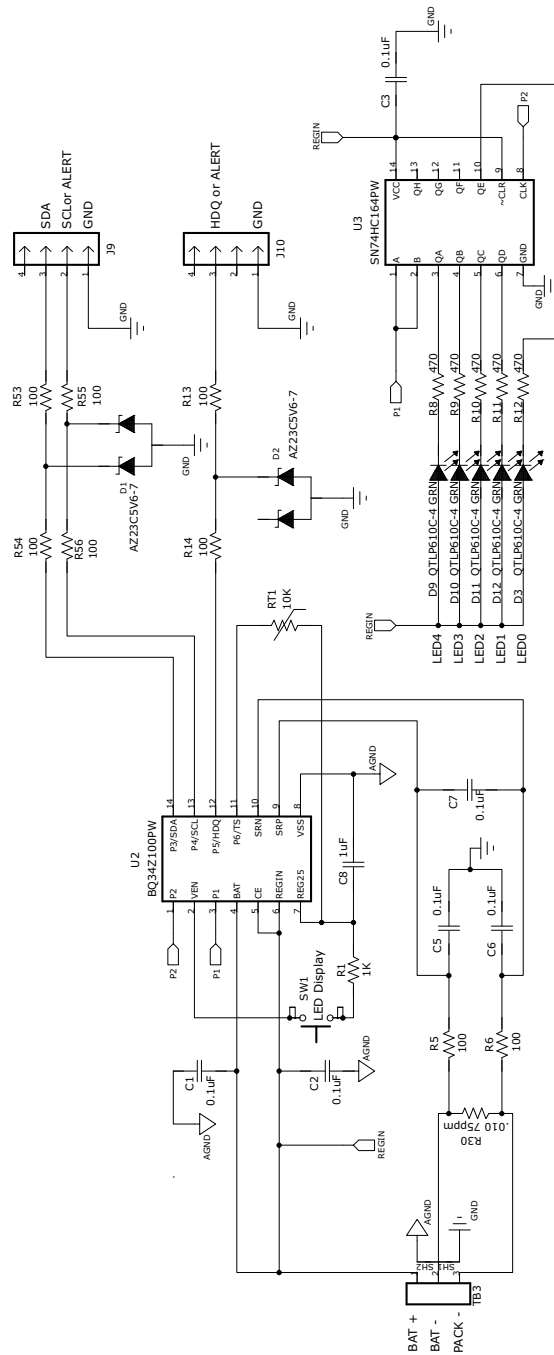

Copyright © 2016, Texas Instruments Incorporated

Figure 8-2. 1-Cell Li-ion and 5-LED Display

The BQ34Z100-R2 can also be used to provide a gas gauge for a multi-cell Li-ion battery with a 5-bar LED display.

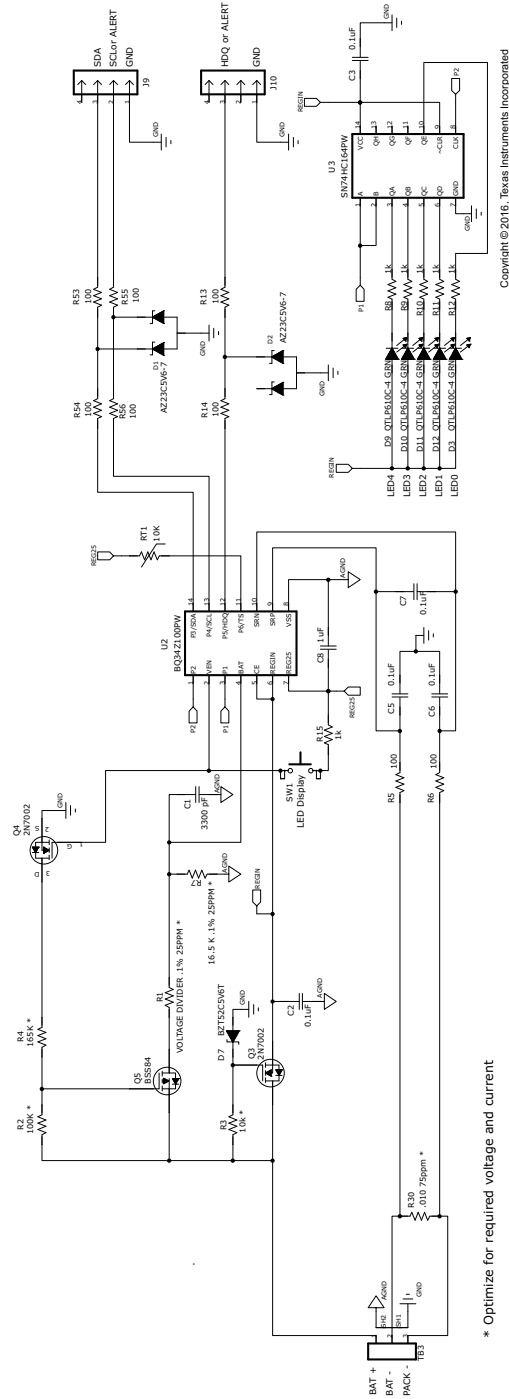

Figure 8-3. Multi-Cell and 5-LED Display

Figure 8-4 shows the BQ34Z100-R2 full features enabled.

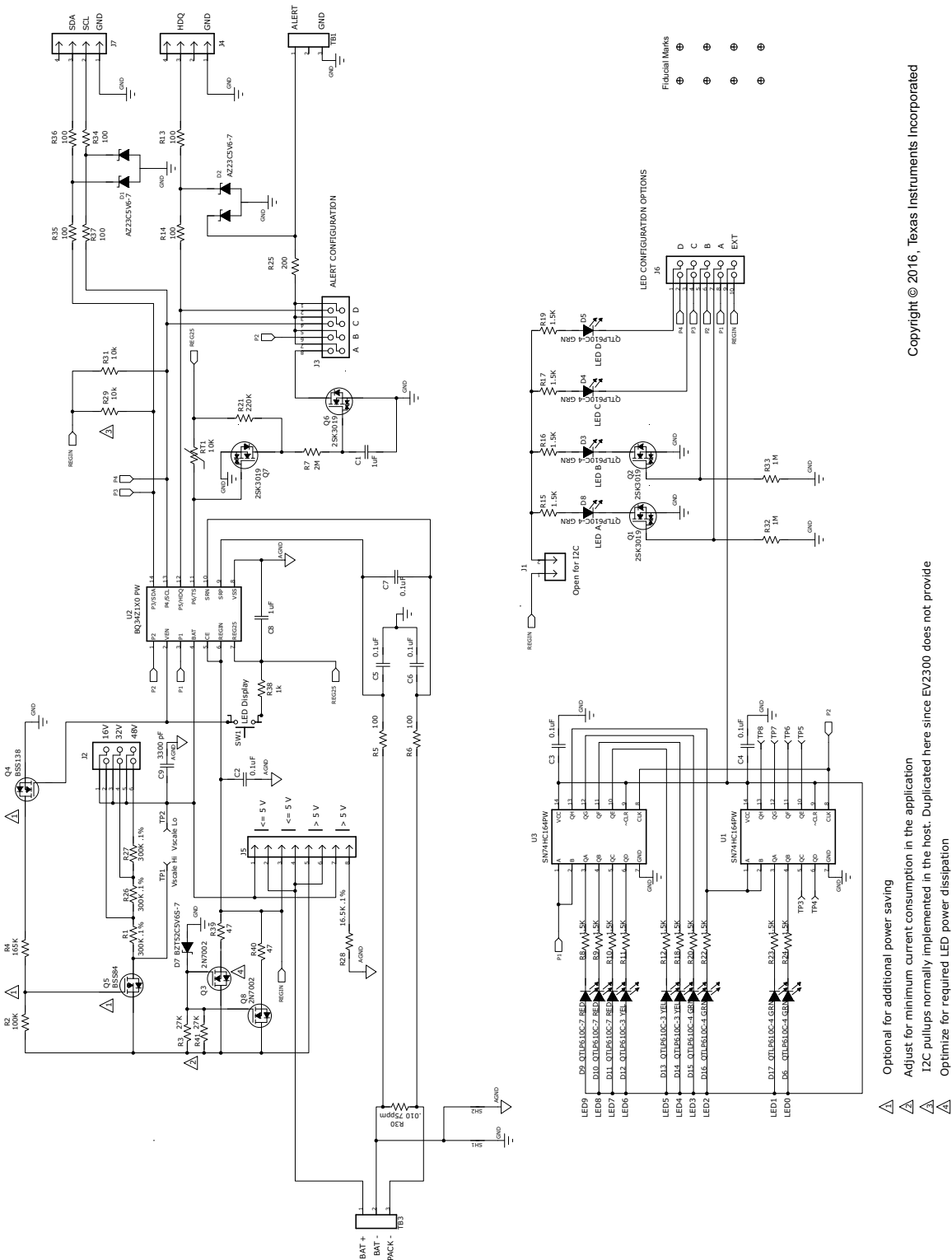

Figure 8-4. Full-Featured Evaluation Module EVM

8.2.1 Design Requirements

For additional design guidelines, refer to the *BQ34Z100 EVM Wide Range Impedance Track Enabled Battery Fuel Gauge User's Guide (SLUU904)*.

- △ Optional for additional power saving
- △ Adjust for minimum current consumption in the application
- △ 12C pullups normally implemented in the host. Duplicated here since EV2300 does not provide
- △ Optimize for required LED power dissipation

Copyright © 2016, Texas Instruments Incorporated

8.2.2 Detailed Design Procedure

8.2.2.1 Step-by-Step Design Procedure

8.2.2.1.1 STEP 1: Review and Modify the Data Flash Configuration Data.

While many of the default parameters in the data flash are suitable for most applications, the following should first be reviewed and modified to match the intended application.

- **Design Capacity:** Enter the value in mAh divided by *CurrScale()* for the battery, even from the “design energy” point of view.
- **Design Energy:** Enter the value in cWh divided by *EnergyScale()*.
- **Cell Charge Voltage Tx-Ty:** Enter the desired cell charge voltage for each JEITA temperature range.

8.2.2.1.2 STEP 2: Review and Modify the Data Flash Configuration Registers.

- **LED_Comm Configuration:** See in the [BQ34Z100-R2 Technical Reference Manual](#) to aid in selection of an LED mode. Note that the pin used for the optional Alert signal is dependent upon the LED mode selected.
- **Alert Configuration:** See the [BQ34Z100-R2 Technical Reference Manual](#) to aid in selection of which faults trigger the ALERT pin.
- **Number of Series Cells**
- **Pack Configuration:** Ensure that the VOLSEL bit is set for multicell applications and cleared for single-cell applications.

8.2.2.1.3 STEP 3: Design and Configure the Voltage Divider.

If the battery contains more than 1-s cells, a voltage divider network is required. Design the divider network, based on the formula below. The voltage division required is from the highest expected battery voltage, down to approximately 900 mV. For example, using a lower leg resistor of 16.5 KΩ where the highest expected voltage is 32000 mV:

$$R_{series} = 16.5 \text{ K}\Omega (32000 \text{ mV} - 900 \text{ mV})/900 \text{ mV} = 570.2 \text{ K}\Omega$$

Based on price and availability, a 600-K resistor or pair of 300-K resistors could be used in the top leg along with a 16.5-K resistor in the bottom leg.

Set the **Voltage Divider** in the Data Flash Calibration section of the Evaluation Software to 32000 mV with *VoltScale()* = 1.

Use the Evaluation Software to calibrate to the applied nominal voltage; for example, 24000 mV. After calibration, a slightly different value appears in the **Voltage Divider** parameter, which can be used as a default value for the project. For the applications with voltage higher than 65535 mV, please refer to the [BQ34Z100-R2 Technical Reference Manual](#).

Following the successful voltage calibration, calculate and apply the value to **Flash Update OK Cell Volt** as: **Flash Update OK Cell Volt** = 2800 mV × **Number Of Series Cells** × 5000 / **Voltage Divider** / *VoltScale()*.

8.2.2.1.4 STEP 4: Determine the Sense Resistor Value.

To ensure accurate current measurement, the input voltage generated across the current sense resistor should not exceed +/-125 mV. For applications with a very high dynamic range, it is allowable to extend this range to absolute maximum of +/-300 mV for overload conditions where a protector device will be taking independent protective action. In such an overloaded state, current reporting and gauging accuracy will not function correctly.

The value of the current sense resistor should be entered into both **CC Gain** and **CC Delta** parameters in the Data Flash Calibration section of the Evaluation Software.

8.2.2.1.5 STEP 5: Review and Modify the Data Flash Gas Gauging Configuration, Data, and State.

- **Load Select:** See *Current Model Used When Load Mode = 0* and *Constant-Power Model Used When Load Mode = 1* in the [BQ34Z100-R2 Technical Reference Manual](#).
- **Load Mode:** See *Current Model Used When Load Mode = 0* and *Constant-Power Model Used When Load Mode =* in the [BQ34Z100-R2 Technical Reference Manual](#).

- **Cell Terminate Voltage:** This is the theoretical voltage where the system begins to fail. It is defined as a zero state-of-charge. Generally, a more conservative level is used to have some reserve capacity. Note the value is for a single cell only.
- **Quit Current:** Generally, this should be set to a value slightly above the expected idle current of the system.
- **Qmax Cell 0:** Start with the C-rate value of your battery.

8.2.2.1.6 STEP 6: Determine and Program the Chemical ID.

Use the BQChem feature in the Evaluation Software to select and program the chemical ID matching your cell. If no match is found, use the procedure defined in TI's ([Mathcad Chemistry Selection Tool \(SLUC138\)](#)).

8.2.2.1.7 STEP 7: Calibrate.

Follow the steps on the **Calibration** screen in the Evaluation Software. Achieving the best possible calibration is important before moving on to Step 8. For mass production, calibration is not required for single-cell applications. For multi-cell applications, only voltage calibration is required. Current and temperature may be calibrated to improve gauging accuracy if needed.

8.2.2.1.8 STEP 8: Run an Optimization Cycle.

Refer to the [Preparing Optimized Default Flash Constants for Specific Battery Types Application Report \(SLUA334B\)](#).

9 Power Supply Recommendations

Power supply requirements for the BQ34Z100-R2 are simplified due to the presence of the internal LDO voltage regulation. The REGIN pin accepts any voltage level between 2.7 V and 4.5 V, which is optimum for a single-cell Li-ion application. For higher battery voltage applications, a simple pre-regulator can be provided to power the bq34Z100-R2 and any optional LEDs. Decoupling the REGIN pin should be done with a 0.1- μ F 10% ceramic X5R capacitor placed close to the device. While the pre-regulator circuit is not critical, special attention should be paid to its quiescent current and power dissipation. The input voltage should handle the maximum battery stack voltage. The output voltage can be centered within the 2.7-V to 4.5-V range as recommended for the REGIN pin.

For high stack count applications, a commercially available LDO is often the best quality solution, but comes with a cost tradeoff. To lower the BOM cost, the following approaches are recommended.

In [Figure 9-1](#), Q1 is used to drop the battery stack voltage to roughly 4 V to power the BQ34Z100-R2 REGIN pin and also to feed the anode of any LEDs used in the application. To avoid unwanted quiescent current consumption, R1 should be set as high as is practical. It is recommended to use a low-current Zener diode.

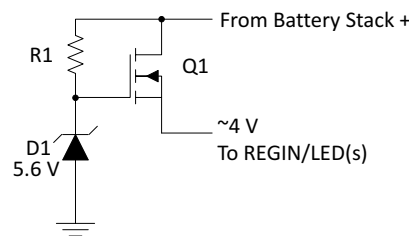

Figure 9-1. Q1 Dropping Battery Stack Voltage to 4 V

Alternatively, if the range of a high-voltage battery stack can be well defined, a simple source follower based on a resistive divider can be used to lower the BOM cost and the quiescent current. For example:

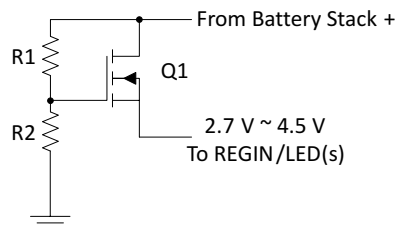

Figure 9-2. Source Follower on a Resistive Divider

Power dissipation of the linear pre-regulator may become an important design decision when multiple LEDs are employed in the application. For example, the BQ34Z100-R2 EVM uses a pair of FETs in parallel to inexpensively dissipate enough power for 10-LED evaluation.

10 Layout

10.1 Layout Guidelines

10.1.1 Introduction

Attention to layout is critical to the success of any battery management circuit board. The mixture of high-current paths with an ultralow-current microcontroller creates the potential for design issues that are not always trivial to solve. Some of the key areas of concern are described in the following sections, and can help to enable success.

10.1.2 Power Supply Decoupling Capacitor

Power supply decoupling from VCC to ground is important for optimal operation of the gas gauge. To keep the loop area small, place this capacitor next to the IC and use the shortest possible traces. A large loop area renders the capacitor useless and forms a small-loop antenna for noise pickup.

Ideally, the traces on each side of the capacitor should be the same length and run in the same direction to avoid differential noise during ESD. If possible, place a via near the VSS pin to a ground plane layer.

10.1.3 Capacitors

Power supply decoupling for the gas gauges requires a pair of 0.1- μ F ceramic capacitors for (BAT) and (VCC) pins. These should be placed reasonably close to the IC without using long traces back to VSS. The LDO voltage regulator, whether external or internal to the main IC, requires a 0.47- μ F ceramic capacitor to be placed fairly close to the regulation output pin. This capacitor is for amplifier loop stabilization and as an energy well for the 2.5-V supply.

10.1.4 Communication Line Protection Components

The 5.6-V Zener diodes, used to protect the communication pins of the gas gauge from ESD, should be located as close as possible to the pack connector. The grounded end of these Zener diodes should be returned to the Pack(-) node rather than to the low-current digital ground system. This way, ESD is diverted away from the sensitive electronics as much as possible.

In some applications, it is sometimes necessary to cause transitions on the communication lines to trigger events that manage the gas gauge power modes. An example of one of these transitions is detecting a sustained low logic level on the communication lines to detect that a pack has been removed. Given that most of the gas gauges do not have internal pulldown networks, it is necessary to add a weak pulldown resistor to accomplish this when there's an absence of a strong pullup resistor on the system side. If the weak pulldown resistor is used, it may take less board space to use a small capacitor in parallel instead of the Zener diode to absorb any ESD transients that are received through communication lines.

10.2 Layout Example

10.2.1 Ground System

The gas gauge requires a low-current ground system separate from the high-current PACK(-) path. ESD ground is defined along the high-current path from the PACK(-) terminal to low-side protector FETs (if present) or the sense resistor. It is important that the low-current ground systems only connect to the BAT(-) path at the sense resistor Kelvin pick-off point. It is recommended to use an optional inner layer ground plane for the low-current ground system. In [Figure 10-1](#), the green is an example of using the low-current ground as a shield for the gas gauge circuit. Notice how it is kept separate from the high-current ground, which is shown in red. The high-current path is joined with the low-current path only at one point, shown with the small blue connection between the two planes.

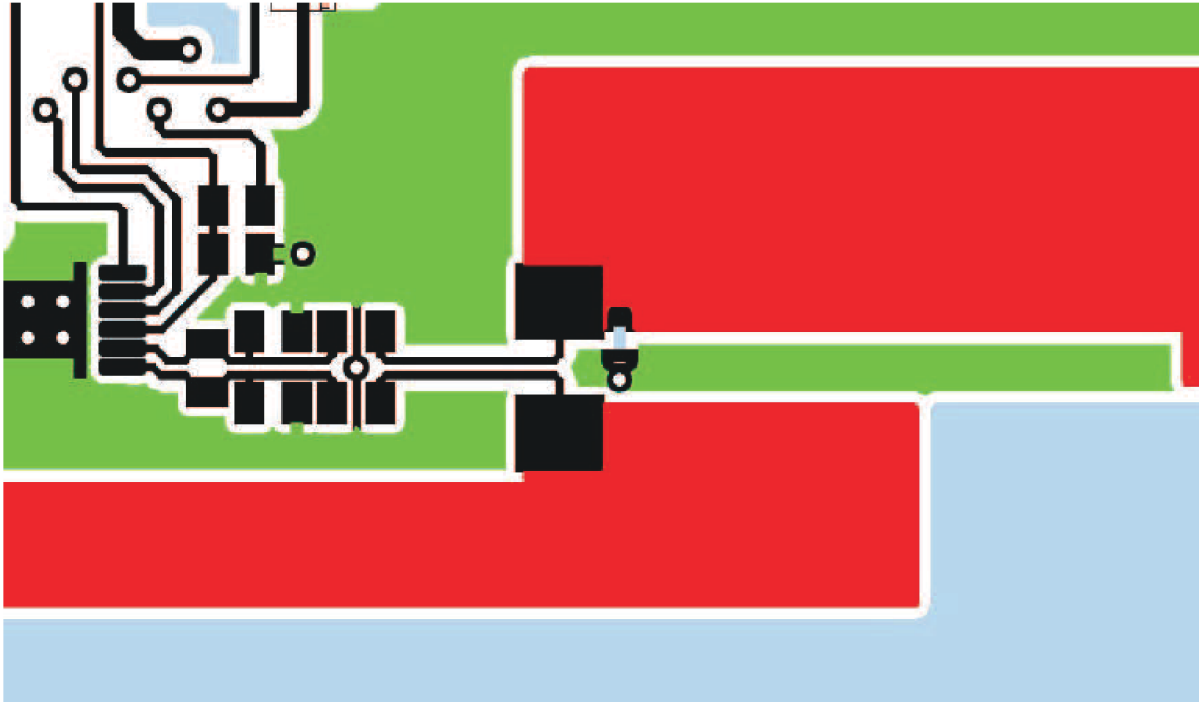

Figure 10-1. Differential Filter Component with Symmetrical Layout

10.2.2 Kelvin Connections

Kelvin voltage sensing is very important to accurately measure current and cell voltage. Notice how the differential connections at the sense resistor do not add any voltage drop across the copper etch that carries the high current path through the sense resistor. See [Figure 10-1](#) and [Figure 10-2](#).

10.2.3 Board Offset Considerations

Although the most important component for board offset reduction is the decoupling capacitor for V_{CC} , additional benefit is possible by using this recommended pattern for the coulomb counter differential low-pass filter network. Maintain the symmetrical placement pattern shown for optimum current offset performance. Use symmetrical shielded differential traces, if possible, from the sense resistor to the 100- Ω resistors, as shown in [Figure 10-2](#).

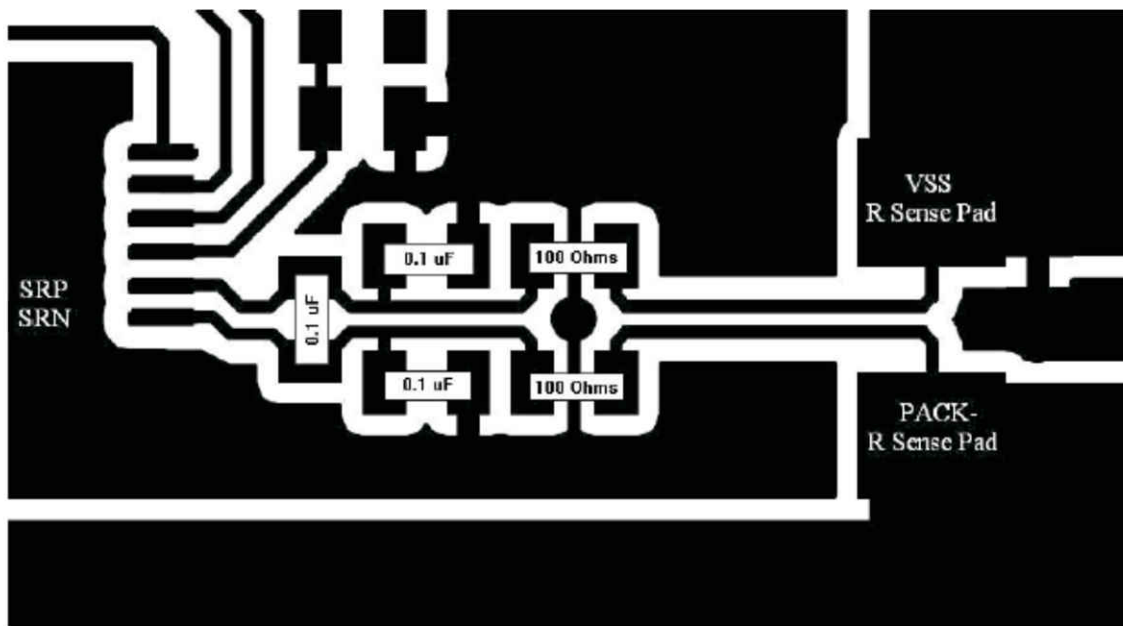

Figure 10-2. Differential Connection Between SRP and SRN Pins with Sense Resistor

10.2.4 ESD Spark Gap

Protect the communication lines from ESD with a spark gap at the connector. Figure 10-3 shows the recommended pattern with its 0.2-mm spacing between the points.

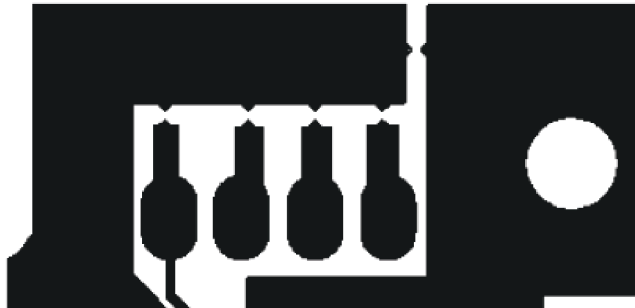

Figure 10-3. Recommended Spark-Gap Pattern Helps Protect Communication Lines from ESD

11 Device and Documentation Support

11.1 Documentation Support

For related documentation, see the following:

- [BQ34Z100-R2 Technical Reference Manual](#)
- [BQ34Z100-R2 High Cell Count and High Capacity Applications application report](#)

11.2 Receiving Notification of Documentation Updates

To receive notification of documentation updates, navigate to the device product folder on [ti.com](#). Click on *Subscribe to updates* to register and receive a weekly digest of any product information that has changed. For change details, review the revision history included in any revised document.

11.3 Support Resources

[TI E2E™ support forums](#) are an engineer's go-to source for fast, verified answers and design help — straight from the experts. Search existing answers or ask your own question to get the quick design help you need.

Linked content is provided "AS IS" by the respective contributors. They do not constitute TI specifications and do not necessarily reflect TI's views; see TI's [Terms of Use](#).

11.4 Trademarks

Impedance Track™ is a trademark of Texas Instruments.

TI E2E™ are trademarks of Texas Instruments.

All trademarks are the property of their respective owners.

11.5 Electrostatic Discharge Caution



This integrated circuit can be damaged by ESD. Texas Instruments recommends that all integrated circuits be handled with appropriate precautions. Failure to observe proper handling and installation procedures can cause damage.

ESD damage can range from subtle performance degradation to complete device failure. Precision integrated circuits may be more susceptible to damage because very small parametric changes could cause the device not to meet its published specifications.

11.6 Glossary

[TI Glossary](#) This glossary lists and explains terms, acronyms, and definitions.

12 Mechanical, Packaging, and Orderable Information

The following pages include mechanical, packaging, and orderable information. This information is the most current data available for the designated devices. This data is subject to change without notice and revision of this document. For browser-based versions of this data sheet, refer to the left-hand navigation.

PACKAGING INFORMATION

Orderable part number	Status (1)	Material type (2)	Package Pins	Package qty Carrier	RoHS (3)	Lead finish/ Ball material (4)	MSL rating/ Peak reflow (5)	Op temp (°C)	Part marking (6)
BQ34Z100PWR-R2	Active	Production	TSSOP (PW) 14	2000 LARGE T&R	Yes	NIPDAU	Level-2-260C-1 YEAR	-40 to 85	34Z100
BQ34Z100PWR-R2.B	Active	Production	TSSOP (PW) 14	2000 LARGE T&R	Yes	NIPDAU	Level-2-260C-1 YEAR	-40 to 85	34Z100

(1) **Status:** For more details on status, see our [product life cycle](#).

(2) **Material type:** When designated, preproduction parts are prototypes/experimental devices, and are not yet approved or released for full production. Testing and final process, including without limitation quality assurance, reliability performance testing, and/or process qualification, may not yet be complete, and this item is subject to further changes or possible discontinuation. If available for ordering, purchases will be subject to an additional waiver at checkout, and are intended for early internal evaluation purposes only. These items are sold without warranties of any kind.

(3) **RoHS values:** Yes, No, RoHS Exempt. See the [TI RoHS Statement](#) for additional information and value definition.

(4) **Lead finish/Ball material:** Parts may have multiple material finish options. Finish options are separated by a vertical ruled line. Lead finish/Ball material values may wrap to two lines if the finish value exceeds the maximum column width.

(5) **MSL rating/Peak reflow:** The moisture sensitivity level ratings and peak solder (reflow) temperatures. In the event that a part has multiple moisture sensitivity ratings, only the lowest level per JEDEC standards is shown. Refer to the shipping label for the actual reflow temperature that will be used to mount the part to the printed circuit board.

(6) **Part marking:** There may be an additional marking, which relates to the logo, the lot trace code information, or the environmental category of the part.

Multiple part markings will be inside parentheses. Only one part marking contained in parentheses and separated by a "~" will appear on a part. If a line is indented then it is a continuation of the previous line and the two combined represent the entire part marking for that device.

Important Information and Disclaimer: The information provided on this page represents TI's knowledge and belief as of the date that it is provided. TI bases its knowledge and belief on information provided by third parties, and makes no representation or warranty as to the accuracy of such information. Efforts are underway to better integrate information from third parties. TI has taken and continues to take reasonable steps to provide representative and accurate information but may not have conducted destructive testing or chemical analysis on incoming materials and chemicals. TI and TI suppliers consider certain information to be proprietary, and thus CAS numbers and other limited information may not be available for release.

In no event shall TI's liability arising out of such information exceed the total purchase price of the TI part(s) at issue in this document sold by TI to Customer on an annual basis.

TAPE AND REEL INFORMATION

QUADRANT ASSIGNMENTS FOR PIN 1 ORIENTATION IN TAPE

*All dimensions are nominal

Device	Package Type	Package Drawing	Pins	SPQ	Reel Diameter (mm)	Reel Width W1 (mm)	A0 (mm)	B0 (mm)	K0 (mm)	P1 (mm)	W (mm)	Pin1 Quadrant
BQ34Z100PWR-R2	TSSOP	PW	14	2000	330.0	12.4	6.9	5.6	1.6	8.0	12.0	Q1

TAPE AND REEL BOX DIMENSIONS

*All dimensions are nominal

Device	Package Type	Package Drawing	Pins	SPQ	Length (mm)	Width (mm)	Height (mm)
BQ34Z100PWR-R2	TSSOP	PW	14	2000	338.1	338.1	20.6



NOTES:

1. All linear dimensions are in millimeters. Any dimensions in parenthesis are for reference only. Dimensioning and tolerancing per ASME Y14.5M.
2. This drawing is subject to change without notice.
3. This dimension does not include mold flash, protrusions, or gate burrs. Mold flash, protrusions, or gate burrs shall not exceed 0.15 mm per side.
4. This dimension does not include interlead flash. Interlead flash shall not exceed 0.25 mm per side.
5. Reference JEDEC registration MO-153.

EXAMPLE BOARD LAYOUT

PW0014A

TSSOP - 1.2 mm max height

SMALL OUTLINE PACKAGE



LAND PATTERN EXAMPLE
EXPOSED METAL SHOWN
SCALE: 10X



4220202/B 12/2023

NOTES: (continued)

- 6. Publication IPC-7351 may have alternate designs.
- 7. Solder mask tolerances between and around signal pads can vary based on board fabrication site.

EXAMPLE STENCIL DESIGN

PW0014A

TSSOP - 1.2 mm max height

SMALL OUTLINE PACKAGE



SOLDER PASTE EXAMPLE
BASED ON 0.125 mm THICK STENCIL
SCALE: 10X

4220202/B 12/2023

NOTES: (continued)

8. Laser cutting apertures with trapezoidal walls and rounded corners may offer better paste release. IPC-7525 may have alternate design recommendations.
9. Board assembly site may have different recommendations for stencil design.

IMPORTANT NOTICE AND DISCLAIMER

TI PROVIDES TECHNICAL AND RELIABILITY DATA (INCLUDING DATASHEETS), DESIGN RESOURCES (INCLUDING REFERENCE DESIGNS), APPLICATION OR OTHER DESIGN ADVICE, WEB TOOLS, SAFETY INFORMATION, AND OTHER RESOURCES "AS IS" AND WITH ALL FAULTS, AND DISCLAIMS ALL WARRANTIES, EXPRESS AND IMPLIED, INCLUDING WITHOUT LIMITATION ANY IMPLIED WARRANTIES OF MERCHANTABILITY, FITNESS FOR A PARTICULAR PURPOSE OR NON-INFRINGEMENT OF THIRD PARTY INTELLECTUAL PROPERTY RIGHTS.

These resources are intended for skilled developers designing with TI products. You are solely responsible for (1) selecting the appropriate TI products for your application, (2) designing, validating and testing your application, and (3) ensuring your application meets applicable standards, and any other safety, security, regulatory or other requirements.

These resources are subject to change without notice. TI grants you permission to use these resources only for development of an application that uses the TI products described in the resource. Other reproduction and display of these resources is prohibited. No license is granted to any other TI intellectual property right or to any third party intellectual property right. TI disclaims responsibility for, and you fully indemnify TI and its representatives against any claims, damages, costs, losses, and liabilities arising out of your use of these resources.

TI's products are provided subject to [TI's Terms of Sale](#), [TI's General Quality Guidelines](#), or other applicable terms available either on ti.com or provided in conjunction with such TI products. TI's provision of these resources does not expand or otherwise alter TI's applicable warranties or warranty disclaimers for TI products. Unless TI explicitly designates a product as custom or customer-specified, TI products are standard, catalog, general purpose devices.

TI objects to and rejects any additional or different terms you may propose.

Copyright © 2025, Texas Instruments Incorporated

Last updated 10/2025

Looking for pricing, stock, or lifecycle information?

Click below to explore more details on WIN SOURCE:

 [View BQ34Z100PWR-R2 on WIN SOURCE](#)

 [Texas Instruments](#) Information

Optimize Your Supply Chain with WIN SOURCE Solutions

-  Global Sourcing Solution
-  Obsolete Management
-  Cost Control Management
-  Shortage Management
-  Alternative Solution
-  Excess Inventory Management