

ISO722x Dual-Channel Digital Isolators

1 Features

- 1, 5, 25, and 150-Mbps Signaling Rate Options
 - Low Channel-to-Channel Output Skew; 1-ns Max
 - Low Pulse-Width Distortion (PWD); 1-ns Max
 - Low Jitter Content; 1 ns Typ at 150 Mbps
- 50 kV/μs Typical Transient Immunity
- Operates with 2.8-V (C-Grade), 3.3-V, or 5-V Supplies
- 4-kV ESD Protection
- High Electromagnetic Immunity
- –40°C to +125°C Operating Range
- Typical 28-Year Life at Rated Voltage
(see [High-Voltage Lifetime of the ISO72x Family of Digital Isolators](#) and [Isolation Capacitor Lifetime Projection](#))
- Safety-Related Certifications
 - VDE Basic Insulation with 4000- V_{PK} V_{IOTM} , 560 V_{PK} V_{IORM} per DIN VDE V 0884-11:2017-01 and DIN EN 61010-1 (VDE 0411-1)
 - 2500 V_{RMS} Isolation per UL 1577
 - CSA Approved for IEC 60950-1 and IEC 62368-1

2 Applications

- Industrial Fieldbus
 - Modbus
 - Profibus™
 - DeviceNet™ Data Buses
- Computer Peripheral Interface
- Servo Control Interface
- Data Acquisition

3 Description

The ISO7220x and ISO7221x family devices are dual-channel digital isolators. To facilitate PCB layout, the channels are oriented in the same direction in the ISO7220x and in opposite directions in the ISO7221x. These devices have a logic input and output buffer separated by TI's silicon-dioxide (SiO₂) isolation barrier, providing galvanic isolation of up to 4000 V_{PK} per VDE. Used in conjunction with isolated power supplies, these devices block high voltage and isolate grounds, as well as prevent noise currents on a data bus or other circuits from entering the local ground and interfering with or damaging sensitive circuitry.

A binary input signal is conditioned, translated to a balanced signal, then differentiated by the capacitive

isolation barrier. Across the isolation barrier, a differential comparator receives the logic transition information, then sets or resets a flip-flop and the output circuit accordingly. A periodic update pulse is sent across the barrier to ensure the proper dc level of the output. If this dc-refresh pulse is not received every 4 μs, the input is assumed to be unpowered or not being actively driven, and the failsafe circuit drives the output to a logic high state.

The small capacitance and resulting time constant provide fast operation with signaling rates available from 0 Mbps (DC) to 150 Mbps (The signaling rate of a line is the number of voltage transitions that are made per second expressed in the units bps). The A-option, B-option, and C-option devices have TTL input thresholds and a noise filter at the input that prevents transient pulses from being passed to the output of the device. The M-option devices have CMOS $V_{CC}/2$ input thresholds and do not have the input noise filter and the additional propagation delay.

The ISO7220x and ISO7221x family of devices require two supply voltages of 2.8 V (C-Grade), 3.3 V, 5 V, or any combination. All inputs are 5-V tolerant when supplied from a 2.8-V or 3.3-V supply and all outputs are 4-mA CMOS.

The ISO7220x and ISO7221x family of devices are characterized for operation over the ambient temperature range of –40°C to +125°C.

Device Information (1)

PART NUMBER	PACKAGE	BODY SIZE (NOM)
ISO7220x	SOIC (8)	4.90 mm × 3.91 mm
ISO7221x		

- (1) For all available packages, see the orderable addendum at the end of the data sheet.

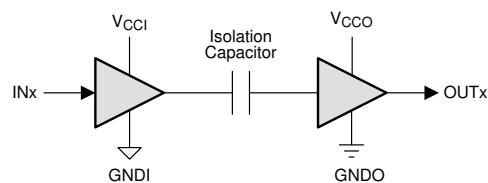

V_{CCI} and $GNDI$ are supply and ground connections respectively for the input channels.

V_{CCO} and $GNDO$ are supply and ground connections respectively for the output channels.

Simplified Schematic



Table of Contents

1 Features	1	6.17 Switching Characteristics—3.3-V V_{CC1} and V_{CC2} Supplies.....	19
2 Applications	1	6.18 Switching Characteristics—2.8-V V_{CC1} and V_{CC2} Supplies.....	19
3 Description	1	6.19 Insulation Characteristics Curves.....	20
4 Revision History	2	6.20 Typical Characteristics.....	21
5 Pin Configuration and Functions	6	7 Parameter Measurement Information	23
6 Specifications	6	8 Detailed Description	25
6.1 Absolute Maximum Ratings.....	6	8.1 Overview.....	25
6.2 ESD Ratings.....	7	8.2 Functional Block Diagram.....	25
6.3 Recommended Operating Conditions.....	8	8.3 Feature Description.....	26
6.4 Thermal Information.....	8	8.4 Device Functional Modes.....	26
6.5 Power Ratings.....	8	9 Application and Implementation	27
6.6 Insulation Specifications.....	9	9.1 Application Information.....	27
6.7 Safety-Related Certifications.....	10	9.2 Typical Application.....	27
6.8 Safety Limiting Values.....	10	10 Power Supply Recommendations	29
6.9 Electrical Characteristics—5-V V_{CC1} and V_{CC2} Supplies.....	11	11 Layout	29
6.10 Electrical Characteristics—5-V V_{CC1} and 3.3-V V_{CC2} Supply.....	12	11.1 Layout Guidelines.....	29
6.11 Electrical Characteristics—3.3-V V_{CC1} and 5-V V_{CC2} Supply.....	13	11.2 Layout Example.....	29
6.12 Electrical Characteristics—3.3-V V_{CC1} and V_{CC2} Supplies.....	14	12 Device and Documentation Support	30
6.13 Electrical Characteristics—2.8-V V_{CC1} and V_{CC2} Supplies.....	14	12.1 Device Support.....	30
6.14 Switching Characteristics—5-V V_{CC1} and V_{CC2} Supplies.....	16	12.2 Documentation Support.....	30
6.15 Switching Characteristics—5-V V_{CC1} and 3.3-V V_{CC2} Supply.....	17	12.3 Related Links.....	30
6.16 Switching Characteristics—3.3-V V_{CC1} and 5-V V_{CC2} Supplies.....	18	12.4 Receiving Notification of Documentation Updates.....	30
		12.5 Support Resources.....	30
		12.6 Trademarks.....	31
		12.7 Electrostatic Discharge Caution.....	31
		12.8 Glossary.....	31
		13 Mechanical, Packaging, and Orderable Information	31

4 Revision History

NOTE: Page numbers for previous revisions may differ from page numbers in the current version.

Changes from Revision P (August 2018) to Revision Q (January 2021) Page

- Removed nominal specifications in the RECOMMENDED OPERATING CONDITIONS table..... 8

Changes from Revision O (April 2017) to Revision P (August 2018) Page

- Changed (VDE V 0884-10):2006-12 to DIN VDE V 0884-11:2017-01 throughout the document..... 1
- Changed CSA Approved for Component Acceptance Notice 5A and IEC 60950-1 to CSA Approved for IEC 60950-1 and IEC 62368-1 throughout the document..... 1
- Added the basic insulation working voltage for CSA in the *Safety-Related Certifications* table..... 10
- Changed the VDE certification number from 40016131 to 40047657 in the *Safety-Related Certifications* table..... 10
- Changed the maximum propagation delay and pulse-width distortion in each *Switching Characteristics* table .. 16
- Added $\pm 10\%$ for the V_{CC1} and V_{CC2} voltages in the condition statement of the *Switching Characteristics—5-V V_{CC1} and V_{CC2} Supplies* table .. 16
- Changed ISO722x to ISO7220 for all part numbers for the Channel-to-channel output skew parameter in each *Switching Characteristic* table..... 16

Changes from Revision N (September 2015) to Revision O (April 2017)	Page
• Changed the <i>Dissipation Characteristics</i> table to <i>Power Ratings</i> . Combined the <i>DIN V VDE V 0884-10 (VDE V 0884-10):2006-12 Insulation Characteristics</i> table <i>IEC Package Characteristics</i> , and <i>IEC 60664-1 Ratings Table</i> in the <i>Insulation Specifications</i> table. Changed the <i>Regulatory Information</i> table to <i>Safety-Related Certifications</i>	8
• Deleted the maximum surge voltage, 4000 V _{PK} for VDE in the <i>Safety-Related Certifications</i> table.....	10
• Changed the CSA information in the <i>Safety-Related Certifications</i> table.....	10

Changes from Revision M (October 2014) to Revision N (September 2015)	Page
• Changed the VDE Certification from: DIN EN 60747-5-5 (VDE 0884-5) to: DIN V VDE V 0884-10 (VDE V 0884-10):2006-12 throughout the document.....	1
• Updated the <i>Simplified Schematic</i> to a higher quality version.....	1
• Changed the max value of the IN and OUT voltage from 6 to V _{CC} + 0.5 in the <i>Absolute Maximum Ratings</i> table.....	6
• Changed L(I01) MIN value from 4.8 to 4 in the <i>IEC Package Characteristics</i> table.....	9
• Added the JEDEC package dimensions note in the <i>IEC Package Characteristics</i> table.....	9
• Changed L(I01) MIN value from 4.8 to 4 in the <i>IEC Package Characteristics</i> table.....	9
• Added the DTI parameter to the <i>IEC Package Characteristics</i> table.....	9
• Changed the DTI test condition From: IEC 60112 / VDE 0303 Part 1 To: DIN EN 60112 (VDE 0303-11); IEC 60112.....	9
• Added = 150°C to insulation resistance test condition in the <i>DIN V VDE V 0884-10 (VDE V 0884-10):2006-12 Insulation Characteristics</i> table.	9
• Added table row with input side V _{CC} = X to the <i>ISO7220x or ISO7221x Function</i> table.....	26

Changes from Revision L (January 2012) to Revision M (August 2014)	Page
• Changed the title of this data sheet to <i>ISO722x Dual Channel Digital Isolators</i>	1
• Added <i>Pin Configuration and Functions</i> section, <i>Handling Rating</i> table, <i>Dissipation Ratings</i> table, <i>Feature Description</i> section, <i>Device Functional Modes</i> , <i>Application and Implementation</i> section, <i>Power Supply Recommendations</i> section, <i>Layout</i> section, <i>Device and Documentation Support</i> section, and <i>Mechanical, Packaging, and Orderable Information</i> section, changed <i>Thermal Information</i> table	1
• Updated the <i>Features</i> section	1
• Added per VDE to 4000 V _{PK} in second sentence of <i>Description</i>	1
• Updated the <i>Regulatory Information</i> Table.....	6
• Added the min and max values to the Storage temperature parameter in the <i>Absolute Maximum Ratings</i> table.....	6
• Changed in ROC table Max col, V _{IH} row from V _{CC} to 5.5	8
• Changed the L(I01) parameter name to external clearance (CLR) and L(I02) to external creepage (CPG). Also changed the input-to-output test voltage (V _{PR}) parameter name to apparent charge (q _{pd})	9
• Changed the <i>Device Options</i> table, Input Threshold column from ≠ symbol to ~ symbol 6 places	26
• Changed <i>Isolation Glossary</i>	30

Changes from Revision K (January 2010) to Revision L (January 2012)	Page
• Changed Feature From: Operates with 3.3-V or 5-V Supplies To: Operates with 2.8-V (C-Grade), 3.3-V or 5-V Supplies.....	1
• Changed Feature From: 4000-V _{peak} Isolation, 560 V _{peak} V _{IORM} To: 4000-V _{PK} V _{IOTM} , 560 V _{PK} V _{IORM} per IEC 60747-5-2 (VDE 0884, Rev2)	1
• Added device options to V _{CC} in the RECOMMENDED OPERATING CONDITIONS table.....	8
• Changed Note: (1) in the RECOMMENDED OPERATING CONDITIONS table.....	8
• Changed the CTI MIN value From: ≥175 V To: ≥400 V.....	9
• Updated the <i>Regulatory Information</i> table.....	10
• Changed I _{CC1} and I _{CC2} test conditions in the 5-V table.....	11

• Changed Table Note: (1).....	11
• Changed I _{CC1} and I _{CC2} test conditions in the V _{CC1} at 5 V, V _{CC2} at 3.3 V table.....	12
• Changed Table Note: (1).....	12
• Changed I _{CC1} and I _{CC2} test conditions in the V _{CC1} at 3.3 V, V _{CC2} at 5 V table.....	13
• Changed Table Note (1).....	13
• Changed I _{CC1} and I _{CC2} test conditions in the V _{CC1} and V _{CC2} at 3.3 V table.....	14
• Changed Table Note (1).....	14
• Added ELECTRICAL and Switching CHARACTERISTICS table for V _{CC1} and V _{CC2} at 2.8 V (ISO722xC-Only)	14
• Changed V _{CC} Undervoltage Threshold vs Free-Air Temperature	21
• Changed Failsafe Delay Time Test Circuit and Voltage Waveforms	23

Changes from Revision J (May 2009) to Revision K () **Page**

• Changed the RECOMMENDED OPERATING CONDITIONS so that Note (2) is associated with all device options in the Input pulse width and Signaling rate.....	8
• Changed Note (2) From: Typical signaling rate under ideal conditions at 25°C. To: Typical signaling rate and Input pulse width are measured at ideal conditions at 25°C.....	8
• Changed column 2 of the AVAILABLE OPTIONS table From: Signaling Rate To: Max Signaling Rate.....	26

Changes from Revision I (December 2008) to Revision J () **Page**

• Changed ISO7221C Marked As column From: TI7221C To: I7221C in the AVAILABLE OPTIONS table.....	26
--	----

Changes from Revision H (May 2008) to Revision I () **Page**

• Added "IEC 61010-1, IEC 60950-1 and CSA Approved" to the UL 1577 FEATURES bullet.....	1
---	---

Changes from Revision G (March 2008) to Revision H () **Page**

• Added Note: (1) to the RECOMMENDED OPERATING CONDITIONS table.....	8
• Added Note: (1) to the ELECTRICAL CHARACTERISTICS: V _{CC1} and V _{CC2} at 5-V table.....	11
• Added Note: (1) to the ELECTRICAL CHARACTERISTICS: V _{CC1} at 5 V, V _{CC2} at 3.3 V table.....	12
• Added Note (1): to the ELECTRICAL CHARACTERISTICS: V _{CC1} at 3.3 V, V _{CC2} at 5 V table.....	13
• Added Note (1): to the ELECTRICAL CHARACTERISTICS: V _{CC1} and V _{CC2} at 3.3 V.....	14

Changes from Revision F (August 2007) to Revision G () **Page**

• Added Part Numbers ISO7220B and ISO7221B to the data sheet.....	1
• Added 5-Mbps Signaling rate to the FEATURES list.....	1
• Added Part Numbers ISO7220B and ISO7221B to the ELECTRICAL CHARACTERISTICS: V _{CC1} and V _{CC2} at 5-V table.....	11
• Added Part Numbers ISO7220B and ISO7221B to the ELECTRICAL CHARACTERISTICS: V _{CC1} at 5 V, V _{CC2} at 3.3 V table.....	12
• Added Part Numbers ISO7220B and ISO7221B to the ELECTRICAL CHARACTERISTICS: V _{CC1} at 3.3 V, V _{CC2} at 5 V table.....	13
• Added Part Numbers ISO7220B and ISO7221B to the ELECTRICAL CHARACTERISTICS: V _{CC1} and V _{CC2} at 3.3 V.....	14
• Added PROPAGATION DELAY vs FREE-AIR TEMPERATURE, ISO722xB, <i>Propagation Delay vs Free-Air Temperature, ISO722xB</i>	21
• Added Part Numbers ISO7220B and ISO7221B to the AVAILABLE OPTIONS table.....	26

Changes from Revision E (July 2007) to Revision F () **Page**

• Added t _{sk(pp)} footnote to the SWITCHING CHARACTERISTICS: V _{CC1} and V _{CC2} at 5-V OPERATION table..	16
• Added t _{sk(o)} footnote to the SWITCHING CHARACTERISTICS: V _{CC1} and V _{CC2} at 5-V OPERATION table....	16

- Added $t_{sk(pp)}$ footnote to the SWITCHING CHARACTERISTICS: V_{CC1} at 5 V, V_{CC2} at 3.3 V OPERATION table 17
- Added $t_{sk(o)}$ footnote to the SWITCHING CHARACTERISTICS: V_{CC1} at 5 V, V_{CC2} at 3.3 V OPERATION table 17
- Added $t_{sk(pp)}$ footnote to the SWITCHING CHARACTERISTICS: V_{CC1} at 3.3 V, V_{CC2} at 5 V OPERATION table 18
- Added $t_{sk(o)}$ footnote to the SWITCHING CHARACTERISTICS: V_{CC1} at 3.3 V, V_{CC2} at 5 V OPERATION table 18
- Added $t_{sk(pp)}$ footnote to the SWITCHING CHARACTERISTICS table..... 19
- Changed 3.3- V_{RMS} Supply Current vs Signaling Rate - Re-scaled the Y-axis.....21
- Changed 5- V_{RMS} Supply Current vs Signaling Rate - New Curves.....21

Changes from Revision D (June 2007) to Revision E () **Page**

- Changed 3.3- V_{RMS} Supply Current vs Signaling Rate - New Curves.....21
- Changed 5- V_{RMS} Supply Current vs Signaling Rate - Re-scaled the Y-axis21

Changes from Revision C (May 2007) to Revision D () **Page**

- Changed *Typical ISO7220x Circuit Hook-Up* - Pin 2 (INA) label From: OUTPUT to INPUT..... 28

Changes from Revision B (May 2007) to Revision C () **Page**

- Added the Signaling rate values to the RECOMMENDED OPERATING CONDITIONS table.....8
- Changed the IEC 60664-1 RATINGS TABLE - Specification I-III test conditions From: Rated mains voltage ≤ 150 VRMS To: Rated mains voltage ≤ 300 VRMS. Added a row for the I-II specifications..... 9
- Added *ISO722xM Jitter vs Signaling Rate* cross reference to the Peak-to-peak eye-pattern jitter of the SWITCHING CHARACTERISTICS table..... 16
- Added *Time-Dependent Dielectric Breakdown Test Results* 28

Changes from Revision A (August 2006) to Revision B () **Page**

- Added the TYPICAL CHARACTERISTIC CURVES to the data sheet..... 21
- Added the PARAMETER MEASUREMENT INFORMATION to the data sheet.....23
- Added the APPLICATION INFORMATION section to the data sheet.....27
- Added the ISOLATION GLOSSARY section to the data sheet30

Changes from Revision * (July 2006) to Revision A () **Page**

- Deleted "and CSA Apporved" from the UL 1577 FEATURES bullet.....1
- Added option A to the AVAILABLE OPTIONS table..... 26

5 Pin Configuration and Functions

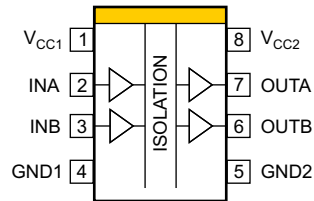

Figure 5-1. ISO7220x D Package 8-Pin SOIC Top View

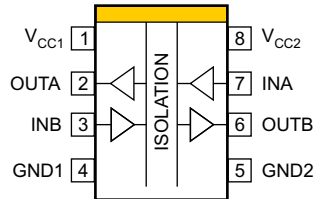

Figure 5-2. ISO7221x D Package 8-Pin SOIC Top View

Table 5-1. Pin Functions

PIN		I/O	DESCRIPTION	
NAME	ISO7220x			ISO7221x
INA	2	7	I	Input, channel A
INB	3	3	I	Input, channel B
GND1	4	4	—	Ground connection for V_{CC1}
GND2	5	5	—	Ground connection for V_{CC2}
OUTA	7	2	O	Output, channel A
OUTB	6	6	O	Output, channel B
V_{CC1}	1	1	—	Power supply, V_{CC1}
V_{CC2}	8	8	—	Power supply, V_{CC2}

6 Specifications

6.1 Absolute Maximum Ratings

over operating free-air temperature range (unless otherwise noted)⁽¹⁾

		MIN	MAX	UNIT
V_{CC}	Supply voltage ⁽²⁾ , V_{CC1} , V_{CC2}	-0.5	6	V
V_I	Voltage at IN, OUT	-0.5	$V_{CC} + 0.5$ ⁽³⁾	V
I_O	Output current	-15	15	mA
T_J	Maximum junction temperature		170	°C
T_{stg}	Storage temperature	-65	150	°C

- (1) Stresses beyond those listed under *Absolute Maximum Ratings* can cause permanent damage to the device. These ratings are stress ratings only and functional operation of the device at these or any other conditions beyond those indicated under *Recommended Operating Conditions* is not implied. Exposure to absolute-maximum-rated conditions for extended periods can affect device reliability.
- (2) All voltage values except differential I/O bus voltages are with respect to network ground pin and are peak voltage values.
- (3) Maximum voltage must not exceed 6 V.

6.2 ESD Ratings

		VALUE	UNIT	
V _(ESD)	Electrostatic discharge	Human body model (HBM), per ANSI/ESDA/JEDEC JS-001, all pins ⁽¹⁾	±4000	V
		Charged device model (CDM), per JEDEC specification JESD22-C101, all pins ⁽²⁾	±1000	V
		Machine Model, ANSI/ESDS5.2-1996	±200	V

(1) JEDEC document JEP155 states that 500-V HBM allows safe manufacturing with a standard ESD control process.

(2) JEDEC document JEP157 states that 250-V CDM allows safe manufacturing with a standard ESD control process.

6.3 Recommended Operating Conditions

		MIN	NOM	MAX	UNIT	
V _{CC}	Supply voltage ⁽²⁾ , V _{CC1} , V _{CC2}	ISO722xA, ISO722xB, ISO722xM		3	5.5	V
		ISO722xC		2.8	5.5	
I _{OH}	High-level output current	-4				mA
I _{OL}	Low-level output current				4	mA
t _{ui}	Input pulse width ⁽¹⁾	ISO722xA		1		μs
		ISO722xB		200		ns
		ISO722xC		40		
		ISO722xM		6.67		
1/t _{ui}	Signaling rate ⁽¹⁾	ISO722xA		0	1000	kbps
		ISO722xB		0	5	Mbps
		ISO722xC		0	25	
		ISO722xM		0	150	
V _{IH}	High-level input voltage	ISO722xA, ISO722xB, ISO722xC		2	5.5	V
V _{IL}	Low-level input voltage	ISO722xA, ISO722xB, ISO722xC		0	0.8	V
V _{IH}	High-level input voltage	ISO722xM		0.7 V _{CC}	V _{CC}	V
V _{IL}	Low-level input voltage	ISO722xM		0	0.3 V _{CC}	V
T _J	Junction temperature	-40			150	°C
H	External magnetic field-strength immunity per IEC 61000-4-8 and IEC 61000-4-9 certification				1000	A/m

- (1) Typical signaling rate and Input pulse width are measured at ideal conditions at 25°C.
 (2) For the 5-V operation, V_{CC1} or V_{CC2} is specified from 4.5 V to 5.5 V.
 For the 3.3-V operation, V_{CC1} or V_{CC2} is specified from 3 V to 3.6 V.
 For the 2.8-V operation, V_{CC1} or V_{CC2} is specified at 2.8 V.

6.4 Thermal Information

THERMAL METRIC ⁽¹⁾		ISO7220x ISO7221x	UNIT	
		D (SOIC)		
		8 PINS		
R _{θJA}	Junction-to-ambient thermal resistance	Low-K Thermal Resistance ⁽²⁾	212	°C/W
		High-K Thermal Resistance	122	
R _{θJC(top)}	Junction-to-case (top) thermal resistance		69.1	°C/W
R _{θJB}	Junction-to-board thermal resistance		47.7	°C/W
ψ _{JT}	Junction-to-top characterization parameter		15.2	°C/W
ψ _{JB}	Junction-to-board characterization parameter		47.2	°C/W
R _{θJC(bot)}	Junction-to-case (bottom) thermal resistance		—	°C/W

- (1) For more information about traditional and new thermal metrics, see the [Semiconductor and IC Package Thermal Metrics application report](#).
 (2) Tested in accordance with the Low-K or High-K thermal metric definitions of EIA/JESD51-3 for leaded surface mount packages.

6.5 Power Ratings

V_{CC1} = V_{CC2} = 5.5 V, T_J = 150°C, C_L = 15 pF, Input a 150 Mbps 50% duty cycle square wave

PARAMETER	TEST CONDITIONS	MIN	TYP	MAX	UNIT
P _D	Device power dissipation, ISO722xM			390	mW

6.6 Insulation Specifications

PARAMETER		TEST CONDITIONS	VALUE	UNIT
GENERAL				
CLR	External clearance ⁽¹⁾	Shortest terminal-to-terminal distance through air	4	mm
CPG	External creepage ⁽¹⁾	Shortest terminal-to-terminal distance across the package surface	4	mm
DTI	Distance through the insulation	Minimum internal gap (internal clearance)	0.008	mm
CTI	Comparative tracking index	DIN EN 60112 (VDE 0303-11); IEC 60112	400	V
	Material group		II	
	Overvoltage category	Rated mains voltage $\leq 150 V_{RMS}$	I-IV	
		Rated mains voltage $\leq 300 V_{RMS}$	I-III	
		Rated mains voltage $\leq 400 V_{RMS}$	I-II	
DIN VDE V 0884-11:2017-01⁽²⁾				
V_{IORM}	Maximum repetitive peak isolation voltage	AC voltage (bipolar)	560	V_{PK}
V_{IOTM}	Maximum transient isolation voltage	$V_{TEST} = V_{IOTM}$ $t = 60$ s (qualification), $t = 1$ s (100% production)	4000	V_{PK}
q_{pd}	Apparent charge ⁽³⁾	Method a: After I/O safety test subgroup 2/3, $V_{ini} = V_{IOTM}$, $t_{ini} = 60$ s; $V_{pd(m)} = 1.2 \times V_{IORM}$, $t_m = 10$ s	≤ 5	pC
		Method a: After environmental tests subgroup 1, $V_{ini} = V_{IOTM}$, $t_{ini} = 60$ s; $V_{pd(m)} = 1.3 \times V_{IORM}$, $t_m = 10$ s	≤ 5	
		Method b1: At routine test (100% production) and preconditioning (type test) $V_{ini} = V_{IOTM}$, $t_{ini} = 1$ s; $V_{pd(m)} = 1.5 \times V_{IORM}$, $t_m = 1$ s	≤ 5	
C_{IO}	Barrier capacitance, input to output ⁽⁴⁾	$V_{IO} = 0.4 \sin(4E6\pi t)$	1	pF
R_{IO}	Isolation resistance, input to output ⁽⁴⁾	$V_{IO} = 500$ V, $T_A = 25^\circ\text{C}$	$> 10^{12}$	Ω
		$V_{IO} = 500$ V, $100^\circ\text{C} \leq T_A \leq 125^\circ\text{C}$	$> 10^{11}$	
		$V_{IO} = 500$ V at $T_S = 150^\circ\text{C}$	$> 10^9$	
	Pollution degree		2	
	Climatic category		40/125/21	
UL 1577				
V_{ISO}	Withstand isolation voltage	$V_{TEST} = V_{ISO} = 2500 V_{RMS}$, $t = 60$ s (qualification); $V_{TEST} = 1.2 \times V_{ISO} = 3000 V_{RMS}$, $t = 1$ s (100% production)	2500	V_{RMS}

- (1) Creepage and clearance requirements should be applied according to the specific equipment isolation standards of an application. Care should be taken to maintain the creepage and clearance distance of a board design to ensure that the mounting pads of the isolator on the printed-circuit board do not reduce this distance. Creepage and clearance on a printed-circuit board become equal in certain cases. Techniques such as inserting grooves and/or ribs on a printed circuit board are used to help increase these specifications.
- (2) This coupler is suitable for *basic electrical insulation* only within the maximum operating ratings. Compliance with the safety ratings shall be ensured by means of suitable protective circuits.
- (3) Apparent charge is electrical discharge caused by a partial discharge (pd).
- (4) All pins on each side of the barrier tied together creating a two-terminal device

6.7 Safety-Related Certifications

VDE	CSA	UL
Certified according to DIN VDE V 0884-11:2017-01 and DIN EN 61010-1 (VDE 0411-1):2011-07	Certified according to IEC 60950-1 and IEC 62368-1	Recognized under UL 1577 Component Recognition Program
Basic Insulation Maximum Transient Overvoltage, 4000 V _{PK} ; Maximum Repetitive Peak Isolation Voltage, 560 V _{PK}	2000 V _{RMS} Isolation rating 400 V _{RMS} Basic insulation and 148 V _{RMS} Reinforced insulation working voltage per CSA 60950-1-07+A1+A2 and IEC 60950-1 2nd Ed. +A1+A2. 300 V _{RMS} Basic insulation working voltage per CSA 62369-1-14 and IEC 62368-1:2014 Ed. 2.	Single protection, 2500 V _{RMS}
Certificate number: 40047657	Master contract number: 220991	File number: E181974

6.8 Safety Limiting Values

Safety limiting⁽¹⁾ intends to minimize potential damage to the isolation barrier upon failure of input or output circuitry. A failure of the I/O can allow low resistance to ground or the supply and, without current limiting, dissipate sufficient power to overheat the die and damage the isolation barrier, potentially leading to secondary system failures.

PARAMETER	TEST CONDITIONS	MIN	TYP	MAX	UNIT
I _S Safety input, output, or supply current	R _{θJA} = 212°C/W, V _I = 5.5 V, T _J = 170°C, T _A = 25°C, see Figure 6-1			124	mA
	R _{θJA} = 212°C/W, V _I = 3.6 V, T _J = 170°C, T _A = 25°C, see Figure 6-1			190	
T _S Safety temperature				150	°C

- (1) The safety-limiting constraint is the maximum junction temperature specified in the data sheet. The power dissipation and junction-to-air thermal impedance of the device installed in the application hardware determines the junction temperature. The assumed junction-to-air thermal resistance in the [Section 6.4](#) table is that of a device installed on a high-K test board for leaded surface-mount packages. The power is the recommended maximum input voltage times the current. The junction temperature is then the ambient temperature plus the power times the junction-to-air thermal resistance.

6.9 Electrical Characteristics—5-V V_{CC1} and V_{CC2} Supplies

V_{CC1} and V_{CC2} at 5 V \pm 10% (over recommended operating conditions unless otherwise noted.)

PARAMETER		TEST CONDITIONS	MIN	TYP	MAX	UNIT
I_{CC1}	V_{CC1} supply current	ISO7220x quiescent, $V_I = V_{CC}$ or 0 V, no load		1	2	mA
		ISO7221 quiescent, $V_I = V_{CC}$ or 0 V, no load		8.5	17	
		ISO7220A and ISO7220B 1 Mbps, 0.5-MHz input clock signal, no load		2	3	mA
		ISO7221A, ISO7221B 1 Mbps, 0.5-MHz input clock signal, no load		10	18	
		ISO7220C, ISO7220M 25 Mbps, 12.5-MHz input clock signal, no load		4	9	mA
		ISO7221C and ISO7221M 25 Mbps, 12.5-MHz input clock signal, no load		12	22	
I_{CC2}	V_{CC2} supply current	ISO7220x quiescent, $V_I = V_{CC}$ or 0 V, no load		16	31	mA
		ISO7221x quiescent, $V_I = V_{CC}$ or 0 V, no load		8.5	17	
		ISO7220A and ISO7220B 1 Mbps, 0.5-MHz input clock signal, no load		17	32	mA
		ISO7221A, ISO7221B 1 Mbps, 0.5-MHz input clock signal, no load		10	18	
		ISO7220C, ISO7220M 25 Mbps, 12.5-MHz input clock signal, no load		20	34	mA
		ISO7221C and ISO7221M 25 Mbps, 12.5-MHz input clock signal, no load		12	22	
V_{OH}	High-level output voltage	$I_{OH} = -4$ mA, See Figure 7-1	$V_{CC} - 0.8$	4.6		V
		$I_{OH} = -20$ μ A, See Figure 7-1	$V_{CC} - 0.1$	5		
V_{OL}	Low-level output voltage	$I_{OL} = 4$ mA, See Figure 7-1		0.2	0.4	V
		$I_{OL} = 20$ μ A, See Figure 7-1		0	0.1	
$V_{I(HYS)}$	Input voltage hysteresis			150		mV
I_{IH}	High-level input current	IN from 0 V to V_{CC}			10	μ A
I_{IL}	Low-level input current	IN from 0 V to V_{CC}	-10			μ A
C_I	Input capacitance to ground	IN at V_{CC} , $V_I = 0.4 \sin(4E6\pi t)$		1		pF
CMTI	Common-mode transient immunity	$V_I = V_{CC}$ or 0 V, See Figure 7-3	25	50		kV/ μ s

6.10 Electrical Characteristics—5-V V_{CC1} and 3.3-V V_{CC2} Supply

V_{CC1} at 5 V \pm 10%, V_{CC2} at 3.3 V \pm 10% (over recommended operating conditions unless otherwise noted.)

PARAMETER	TEST CONDITIONS	MIN	TYP	MAX	UNIT
I_{CC1} V_{CC1} supply current	ISO7220x quiescent, $V_I = V_{CC}$ or 0 V, no load		1	2	mA
	ISO7221x quiescent, $V_I = V_{CC}$ or 0 V, no load		8.5	17	
	ISO7220A and ISO7220B 1 Mbps, 0.5-MHz input clock signal, no load		2	3	mA
	ISO7221A and ISO7221B 1 Mbps, 0.5-MHz input clock signal, no load		10	18	
	ISO7220C and ISO7220M 25 Mbps, 12.5-MHz input clock signal, no load		4	9	mA
	ISO7221C and ISO7221M 25 Mbps, 12.5-MHz input clock signal, no load		12	22	
I_{CC2} V_{CC2} supply current	ISO7220x quiescent, $V_I = V_{CC}$ or 0 V, no load		8	18	mA
	ISO7221x quiescent, $V_I = V_{CC}$ or 0 V, no load		4.3	9.5	
	ISO7220A and ISO7220B 1 Mbps, 0.5-MHz input clock signal, no load		9	19	mA
	ISO7221A and ISO7221B 1 Mbps, 0.5-MHz input clock signal, no load		5	11	
	ISO7220C and ISO7220M 25 Mbps, 12.5-MHz input clock signal, no load		10	20	mA
	ISO7221C and ISO7221M 25 Mbps, 12.5-MHz input clock signal, no load		6	12	
V_{OH} High-level output voltage	ISO7220x, ISO7221x (3.3-V side), $I_{OH} = -4$ mA, See Figure 7-1	$V_{CC} - 0.4$			V
	ISO7221x (5-V side), $I_{OH} = -4$ mA, See Figure 7-1	$V_{CC} - 0.8$			
	All devices, $I_{OH} = -20$ μ A, See Figure 7-1	$V_{CC} - 0.1$			
V_{OL} Low-level output voltage	$I_{OL} = 4$ mA, See Figure 7-1			0.4	V
	$I_{OL} = 20$ μ A, See Figure 7-1			0.1	
$V_{I(HYS)}$ Input voltage hysteresis			150		mV
I_{IH} High-level input current	IN from 0 V to V_{CC}			10	μ A
I_{IL} Low-level input current	IN from 0 V to V_{CC}	-10			μ A
C_I Input capacitance to ground	IN at V_{CC} , $V_I = 0.4 \sin(4E6\pi t)$		1		pF
CMTI Common-mode transient immunity	$V_I = V_{CC}$ or 0 V, See Figure 7-3	15	40		kV/ μ s

6.11 Electrical Characteristics—3.3-V V_{CC1} and 5-V V_{CC2} Supply

V_{CC1} at 3.3 V \pm 10%, V_{CC2} at 5 V \pm 10% (over recommended operating conditions unless otherwise noted.)

PARAMETER		TEST CONDITIONS	MIN	TYP	MAX	UNIT
I_{CC1}	V_{CC1} supply current	ISO7220x quiescent, $V_I = V_{CC}$ or 0 V, no load		0.6	1	mA
		ISO7221x quiescent, $V_I = V_{CC}$ or 0 V, no load		4.3	9.5	
		ISO7220A and ISO7220B 1 Mbps, 0.5-MHz input clock signal, no load		1	2	mA
		ISO7221A and ISO7221B 1 Mbps, 0.5-MHz input clock signal, no load		5	11	
		ISO7220C and ISO7220M 25 Mbps, 12.5-MHz input clock signal, no load		2	4	mA
		ISO7221C and ISO7221M 25 Mbps, 12.5-MHz input clock signal, no load		6	12	
I_{CC2}	V_{CC2} supply current	ISO7220x quiescent, $V_I = V_{CC}$ or 0 V, no load		16	31	mA
		ISO7221x quiescent, $V_I = V_{CC}$ or 0 V, no load		8.5	17	
		ISO7220A and ISO7220B 1 Mbps, 0.5-MHz input clock signal, no load		18	32	mA
		ISO7221A and ISO7221B 1 Mbps, 0.5-MHz input clock signal, no load		10	18	
		ISO7220C and ISO7220M 25 Mbps, 12.5-MHz input clock signal, no load		20	34	mA
		ISO7221C and ISO7221M 25 Mbps, 12.5-MHz input clock signal, no load		12	22	
V_{OH}	High-level output voltage	ISO7220x and ISO7221x (5-V side), $I_{OH} = -4$ mA, See Figure 7-1	$V_{CC} - 0.8$			V
		ISO7221x (3.3-V side), $I_{OH} = -4$ mA, See Figure 7-1	$V_{CC} - 0.4$			
		All devices, $I_{OH} = -20$ μ A, See Figure 7-1	$V_{CC} - 0.1$			
V_{OL}	Low-level output voltage	$I_{OL} = 4$ mA, See Figure 7-1			0.4	V
		$I_{OL} = 20$ μ A, See Figure 7-1		0	0.1	
$V_{I(HYS)}$	Input threshold voltage hysteresis			150		mV
I_{IH}	High-level input current	IN from 0 V or V_{CC}			10	μ A
I_{IL}	Low-level input current	IN from 0 V or V_{CC}		-10		μ A
C_I	Input capacitance to ground	IN at V_{CC} , $V_I = 0.4 \sin(4E6\pi t)$		1		pF
CMTI	Common-mode transient immunity	$V_I = V_{CC}$ or 0 V, See Figure 7-3	15	40		kV/ μ s

6.12 Electrical Characteristics—3.3-V V_{CC1} and V_{CC2} Supplies

V_{CC1} and V_{CC2} at 3.3 V \pm 10% (over recommended operating conditions unless otherwise noted.)⁽¹⁾

PARAMETER		TEST CONDITIONS	MIN	TYP	MAX	UNIT
I_{CC1}	V_{CC2} supply current	ISO7220x quiescent, $V_I = V_{CC}$ or 0 V, no load		0.6	1	mA
		ISO7221x quiescent, $V_I = V_{CC}$ or 0 V, no load		4.3	9.5	
		ISO7220A and ISO7220B 1 Mbps, 0.5-MHz input clock signal, no load		1	2	mA
		ISO7221A and ISO7221B 1 Mbps, 0.5-MHz input clock signal, no load		5	11	
		ISO7220C and ISO7220M 25 Mbps, 12.5-MHz input clock signal, no load		2	4	mA
		ISO7221C and ISO7221M 25 Mbps, 12.5-MHz input clock signal, no load		6	12	
I_{CC2}	V_{CC2} supply current	ISO7220x quiescent, $V_I = V_{CC}$ or 0 V, no load		8	18	mA
		ISO7221x quiescent, $V_I = V_{CC}$ or 0 V, no load		4.3	9.5	
		ISO7220A and ISO7220B 1 Mbps, 0.5-MHz input clock signal, no load		9	19	mA
		ISO7221A and ISO7221B 1 Mbps, 0.5-MHz input clock signal, no load		5	11	
		ISO7220C and ISO7220M 25 Mbps, 12.5-MHz input clock signal, no load		10	20	mA
		ISO7221C and ISO7221M 25 Mbps, 12.5-MHz input clock signal, no load		6	12	
V_{OH}	High-level output voltage	$I_{OH} = -4$ mA, See Figure 7-1	$V_{CC} - 0.4$	3	V	
		$I_{OH} = -20$ μ A, See Figure 7-1	$V_{CC} - 0.1$	3.3		
V_{OL}	Low-level output voltage	$I_{OL} = 4$ mA, See Figure 7-1		0.2		0.4
		$I_{OL} = 20$ μ A, See Figure 7-1		0		0.1
$V_{I(HYS)}$	Input voltage hysteresis			150	mV	
I_{IH}	High-level input current	IN from 0 V or V_{CC}			10	μ A
I_{IL}	Low-level input current	IN from 0 V or V_{CC}	-10			μ A
C_I	Input capacitance to ground	IN at V_{CC} , $V_I = 0.4 \sin(4E6\pi t)$		1		pF
CMTI	Common-mode transient immunity	$V_I = V_{CC}$ or 0 V, See Figure 7-3	15	40		kV/ μ s

(1) For the 3.3-V operation, V_{CC1} or V_{CC2} is specified from 3 V to 3.6 V.

6.13 Electrical Characteristics—2.8-V V_{CC1} and V_{CC2} Supplies

V_{CC1} and V_{CC2} at 2.8 V (over recommended operating conditions unless otherwise noted.) 2.8-V operation is only specified for ISO722xC with production screening starting in January 2012. The first two digits of the Lot Trace Code (YMSLLLLG4) written on top of each device can be used to identify year and month of production respectively.

PARAMETER		TEST CONDITIONS	MIN	TYP	MAX	UNIT
I_{CC1}	V_{CC1} supply current	ISO7220C quiescent, $V_I = V_{CC}$ or 0 V, no load		0.4	0.9	mA
		ISO7221C quiescent, $V_I = V_{CC}$ or 0 V, no load		3.7	7.5	
		ISO7220C 25 Mbps, 12.5-MHz input clock signal, no load		1.5	3.5	mA
		ISO7221C 25 Mbps, 12.5-MHz input clock signal, no load		4.5	10	
I_{CC2}	V_{CC2} supply current	ISO7220C quiescent, $V_I = V_{CC}$ or 0 V, no load		6.8	15	mA
		ISO7221C quiescent, $V_I = V_{CC}$ or 0 V, no load		3.7	7.5	
		ISO7220C 25 Mbps, 12.5-MHz input clock signal, no load		9	17	mA
		ISO7221C 25 Mbps, 12.5-MHz input clock signal, no load		4.5	10	
V_{OH}	High-level output voltage	$I_{OH} = -4$ mA, See Figure 7-1	$V_{CC} - 0.6$	2.55	V	
		$I_{OH} = -20$ μ A, See Figure 7-1	$V_{CC} - 0.1$	2.8		
V_{OL}	Low-level output voltage	$I_{OL} = 4$ mA, See Figure 7-1		0.25		0.6
		$I_{OL} = 20$ μ A, See Figure 7-1		0		0.1
$V_{I(HYS)}$	Input voltage hysteresis			150	mV	
I_{IH}	High-level input current	IN from 0 V or V_{CC}			10	μ A
I_{IL}	Low-level input current	IN from 0 V or V_{CC}	-10			μ A

V_{CC1} and V_{CC2} at 2.8 V (over recommended operating conditions unless otherwise noted.) 2.8-V operation is only specified for ISO722xC with production screening starting in January 2012. The first two digits of the Lot Trace Code (YMSLLLLG4) written on top of each device can be used to identify year and month of production respectively.

PARAMETER		TEST CONDITIONS	MIN	TYP	MAX	UNIT
C_i	Input capacitance to ground	IN at V_{CC} , $V_i = 0.4 \sin(4E6\pi t)$		1		pF
CMTI	Common-mode transient immunity	$V_i = V_{CC}$ or 0 V, See Figure 7-3	10	30		kV/ μ s

6.14 Switching Characteristics—5-V V_{CC1} and V_{CC2} Supplies

V_{CC1} and V_{CC2} at 5 V \pm 10% (over recommended operating conditions unless otherwise noted.)

PARAMETER		TEST CONDITIONS	MIN	TYP	MAX	UNIT
t_{PLH} , t_{PHL}	Propagation delay	ISO722xA, see Figure 7-1	280	405	600	ns
PWD	Pulse-width distortion $ t_{PHL} - t_{PLH} ^{(1)}$		1	18	ns	
t_{PLH} , t_{PHL}	Propagation delay	ISO722xB, see Figure 7-1	42	55	70	ns
PWD	Pulse-width distortion $ t_{PHL} - t_{PLH} ^{(1)}$		1	3	ns	
t_{PLH} , t_{PHL}	Propagation delay	ISO722xC, see Figure 7-1	22	32	42	ns
PWD	Pulse-width distortion $ t_{PHL} - t_{PLH} ^{(1)}$		1	2	ns	
t_{PLH} , t_{PHL}	Propagation delay	ISO722xM, see Figure 7-1	6	10	16	ns
PWD	Pulse-width distortion $ t_{PHL} - t_{PLH} ^{(1)}$		0.5	1	ns	
$t_{sk(pp)}$	Part-to-part skew ⁽²⁾	ISO722xA			180	ns
		ISO722xB			17	
		ISO722xC			10	
		ISO722xM			3	
$t_{sk(o)}$	Channel-to-channel output skew ⁽³⁾	ISO7220A		3	15	ns
		ISO7220B		0.6	3	
		ISO7220C, ISO7220M		0.2	1	
t_r	Output signal rise time	See Figure 7-1		1		ns
t_f	Output signal fall time			1		ns
t_{fs}	Failsafe output delay time from input power loss	See Figure 7-2		3		μ s
$t_{jit(pp)}$	Peak-to-peak eye-pattern jitter	ISO722xM, 150 Mbps PRBS NRZ data, 5-bit max same polarity input, both channels, See Figure 7-4 , Figure 6-13		1		ns
		ISO722xM, 150 Mbps unrestricted bit run length data input, both channels, See Figure 7-4		2		

- (1) Also referred to as pulse skew.
- (2) $t_{sk(pp)}$ is the magnitude of the difference in propagation delay times between any specified pins of two devices when both devices operate with the same supply voltages, at the same temperature, and have identical packages and test circuits.
- (3) $t_{sk(o)}$ is the skew between specified outputs of a single device with all driving inputs connected together and the outputs switching in the same direction while driving identical specified loads.

6.15 Switching Characteristics—5-V V_{CC1} and 3.3-V V_{CC2} Supply

V_{CC1} at 5 V \pm 10%, V_{CC2} at 3.3 V \pm 10% (over recommended operating conditions unless otherwise noted.)

PARAMETER		TEST CONDITIONS	MIN	TYP	MAX	UNIT
t_{PLH} , t_{PHL}	Propagation delay	ISO722xA, see Figure 7-1	285	410	585	ns
PWD	Pulse-width distortion $ t_{PHL} - t_{PLH} ^{(1)}$		1	18	ns	
t_{PLH} , t_{PHL}	Propagation delay	ISO722xB, see Figure 7-1	45	58	75	ns
PWD	Pulse-width distortion $ t_{PHL} - t_{PLH} ^{(1)}$		1	3	ns	
t_{PLH} , t_{PHL}	Propagation delay	ISO722xC, see Figure 7-1	25	36	48	ns
PWD	Pulse-width distortion $ t_{PHL} - t_{PLH} ^{(1)}$		1	2	ns	
t_{PLH} , t_{PHL}	Propagation delay	ISO722xM, see Figure 7-1	7	12	20	ns
PWD	Pulse-width distortion $ t_{PHL} - t_{PLH} ^{(1)}$		0.5	1	ns	
$t_{sk(pp)}$	Part-to-part skew ⁽²⁾	ISO722xA			180	ns
		ISO722xB			17	
		ISO722xC			10	
		ISO722xM			5	
$t_{sk(o)}$	Channel-to-channel output skew ⁽³⁾	ISO7220A		3	15	ns
		ISO7220B		0.6	3	
		ISO7220C, ISO7220M		0.2	1	
t_r	Output signal rise time	See Figure 7-1		2		ns
t_f	Output signal fall time			2		ns
t_{fs}	Failsafe output delay time from input power loss	See Figure 7-2		3		μ s
$t_{jit(pp)}$	Peak-to-peak eye-pattern jitter	ISO722xM, 150 Mbps PRBS NRZ data, 5-bit max same polarity input, both channels, See Figure 7-4 , Figure 6-13		1		ns
		ISO722xM, 150 Mbps unrestricted bit run length data input, both channels, See Figure 7-4		2		

(1) Also referred to as pulse skew.

(2) $t_{sk(pp)}$ is the magnitude of the difference in propagation delay times between any specified pins of two devices when both devices operate with the same supply voltages, at the same temperature, and have identical packages and test circuits.

(3) $t_{sk(o)}$ is the skew between specified outputs of a single device with all driving inputs connected together and the outputs switching in the same direction while driving identical specified loads.

6.16 Switching Characteristics—3.3-V_{CC1} and 5-V V_{CC2} Supplies

V_{CC1} at 3.3 V ± 10%, V_{CC2} at 5 V ± 10% (over recommended operating conditions unless otherwise noted.)

PARAMETER		TEST CONDITIONS	MIN	TYP	MAX	UNIT
t _{PLH} , t _{PHL}	Propagation delay	ISO722xA, see Figure 7-1	285	395	605	ns
PWD	Pulse-width distortion t _{PHL} – t _{PLH} (1)		1	22	ns	
t _{PLH} , t _{PHL}	Propagation delay	ISO722xB, see Figure 7-1	45	58	75	ns
PWD	Pulse-width distortion t _{PHL} – t _{PLH} (1)		1	4	ns	
t _{PLH} , t _{PHL}	Propagation delay	ISO722xC, see Figure 7-1	25	36	48	ns
PWD	Pulse-width distortion t _{PHL} – t _{PLH} (1)		1	3	ns	
t _{PLH} , t _{PHL}	Propagation delay	ISO722xM, see Figure 7-1	7	12	21	ns
PWD	Pulse-width distortion t _{PHL} – t _{PLH} (1)		0.5	1	ns	
t _{sk(pp)}	Part-to-part skew (2)	ISO722xA			190	ns
		ISO722xB			17	
		ISO722xC			10	
		ISO722xM			5	
t _{sk(o)}	Channel-to-channel output skew (3)	ISO7220A		3	15	ns
		ISO7220B		0.6	3	
		ISO7220C, ISO7220M		0.2	1	
t _r	Output signal rise time	See Figure 7-1		1		ns
t _f	Output signal fall time			1		ns
t _{fs}	Failsafe output delay time from input power loss	See Figure 7-2		3		µs
t _{jit(pp)}	Peak-to-peak eye-pattern jitter	ISO722xM, 150 Mbps PRBS NRZ data, 5-bit max same polarity input, both channels, see Figure 7-4 , Figure 6-13		1		ns
		ISO722xM, 150 Mbps unrestricted bit run length data input, both channels, see Figure 7-4		2		

- (1) Also referred to as pulse skew.
- (2) t_{sk(pp)} is the magnitude of the difference in propagation delay times between any specified pins of two devices when both devices operate with the same supply voltages, at the same temperature, and have identical packages and test circuits.
- (3) t_{sk(o)} is the skew between specified outputs of a single device with all driving inputs connected together and the outputs switching in the same direction while driving identical specified loads.

6.17 Switching Characteristics—3.3-V V_{CC1} and V_{CC2} Supplies

V_{CC1} and V_{CC2} at 3.3 V \pm 10% (over recommended operating conditions unless otherwise noted.)

PARAMETER	TEST CONDITIONS	MIN	TYP	MAX	UNIT
t_{PLH} , t_{PHL} Propagation delay	ISO722xA, see Figure 7-1	290	400	610	ns
PWD Pulse-width distortion $ t_{PHL} - t_{PLH} ^{(1)}$			1	22	ns
t_{PLH} , t_{PHL} Propagation delay	ISO722xB, see Figure 7-1	46	62	78	ns
PWD Pulse-width distortion $ t_{PHL} - t_{PLH} ^{(1)}$			1	4	ns
t_{PLH} , t_{PHL} Propagation delay	ISO722xC, see Figure 7-1	26	40	52	ns
PWD Pulse-width distortion $ t_{PHL} - t_{PLH} ^{(1)}$			1	3	ns
t_{PLH} , t_{PHL} Propagation delay	ISO722xM, see Figure 7-1	8	16	25	ns
PWD Pulse-width distortion $ t_{PHL} - t_{PLH} ^{(1)}$			0.5	1	ns
$t_{sk(pp)}$ Part-to-part skew ⁽²⁾	ISO722xA			190	ns
	ISO722xB			17	
	ISO722xC			10	
	ISO722xM			5	
$t_{sk(o)}$ Channel-to-channel output skew ⁽³⁾	ISO7220A		3	15	ns
	ISO7220B		0.6	3	
	ISO7220C, ISO7220M		0.2	1	
t_r Output signal rise time	See Figure 7-1		2		ns
t_f Output signal fall time			2		ns
t_{fs} Failsafe output delay time from input power loss	See Figure 7-2		3		μ s
$t_{jit(pp)}$ Peak-to-peak eye-pattern jitter	ISO722xM, 150 Mbps PRBS NRZ data, 5-bit max same polarity input, both channels, See Figure 7-4, Figure 6-13		1		ns
	ISO722xM, 150 Mbps unrestricted bit run length data input, both channels, See Figure 7-4		2		

(1) Also referred to as pulse skew.

(2) $t_{sk(pp)}$ is the magnitude of the difference in propagation delay times between any specified pins of two devices when both devices operate with the same supply voltages, at the same temperature, and have identical packages and test circuits.

(3) $t_{sk(o)}$ is the skew between specified outputs of a single device with all driving inputs connected together and the outputs switching in the same direction while driving identical specified loads.

6.18 Switching Characteristics—2.8-V V_{CC1} and V_{CC2} Supplies

V_{CC1} and V_{CC2} at 2.8 V (over recommended operating conditions unless otherwise noted.)

PARAMETER	TEST CONDITIONS	MIN	TYP	MAX	UNIT
t_{PLH} , t_{PHL} Propagation delay	ISO722xC, see Figure 7-1	26	45	65	ns
PWD Pulse-width distortion $ t_{PHL} - t_{PLH} ^{(1)}$			1.5	5	ns
$t_{sk(pp)}$ Part-to-part skew ⁽²⁾	ISO722xC			12	ns
$t_{sk(o)}$ Channel-to-channel output skew ⁽³⁾	ISO7220C		0.2	5	ns
t_r Output signal rise time	See Figure 7-1		2		ns
t_f Output signal fall time				2	
t_{fs} Failsafe output delay time from input power loss	See Figure 7-2		4.6		μ s

(1) Also referred to as pulse skew.

(2) $t_{sk(pp)}$ is the magnitude of the difference in propagation delay times between any specified pins of two devices when both devices operate with the same supply voltages, at the same temperature, and have identical packages and test circuits.

(3) $t_{sk(o)}$ is the skew between specified outputs of a single device with all driving inputs connected together and the outputs switching in the same direction while driving identical specified loads.

6.19 Insulation Characteristics Curves

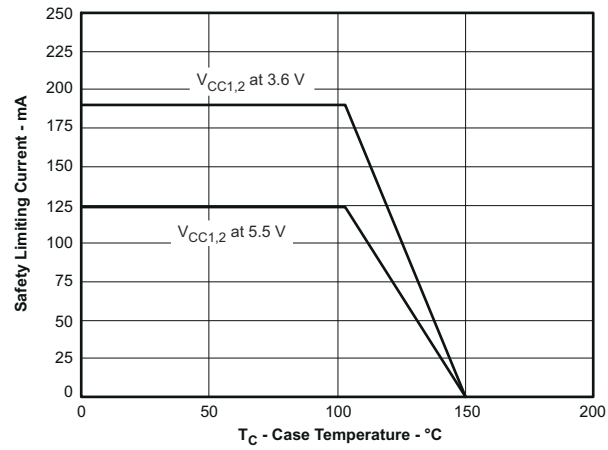

Figure 6-1. Thermal Derating Curve for Limiting Current per VDE

6.20 Typical Characteristics

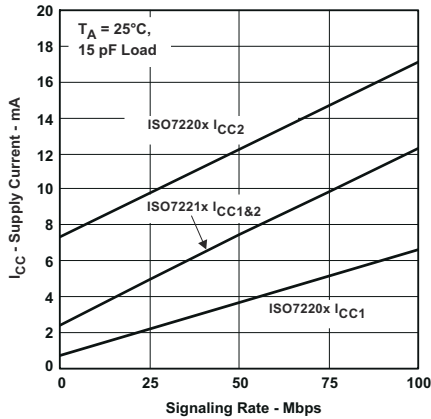

Figure 6-2. 3.3-V_{RMS} Supply Current vs Signaling Rate (Mbps)

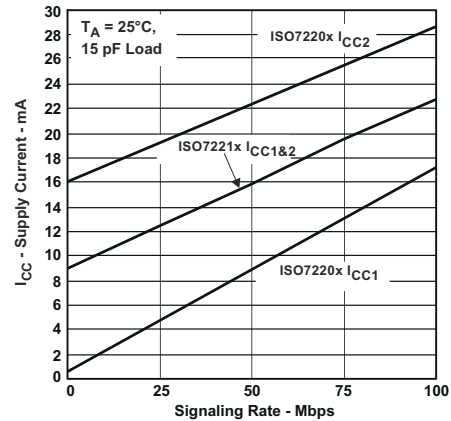

Figure 6-3. 5-V_{RMS} Supply Current vs Signaling Rate (Mbps)

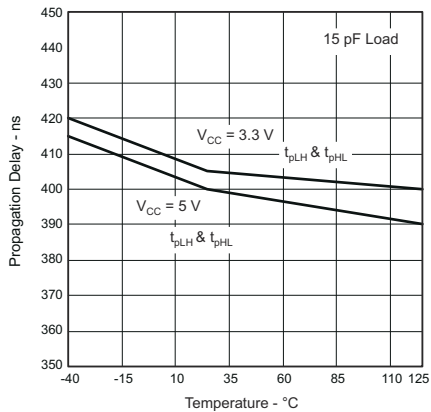

Figure 6-4. Propagation Delay vs Free-Air Temperature, ISO722xA

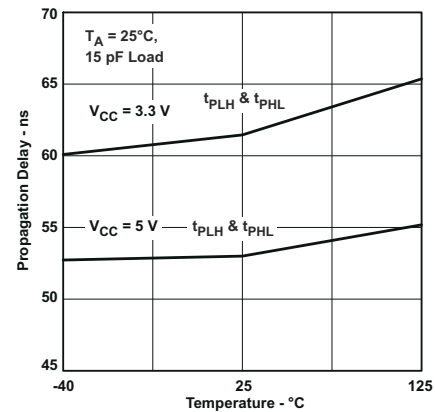

Figure 6-5. Propagation Delay vs Free-Air Temperature, ISO722xB

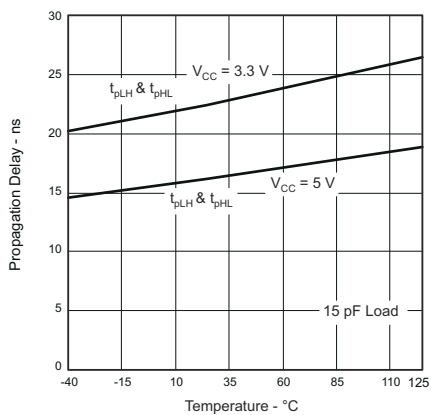

Figure 6-6. Propagation Delay vs Free-Air Temperature, ISO722xC

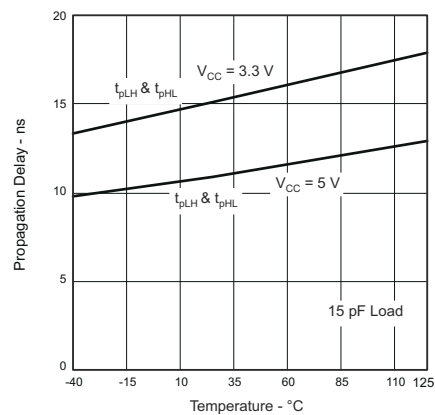

Figure 6-7. Propagation Delay vs Free-Air Temperature, ISO722xM

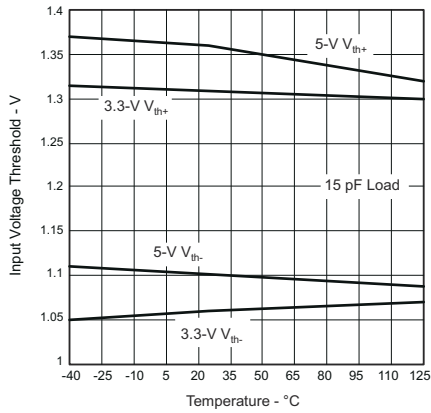

Figure 6-8. ISO722xA, ISO722xB and ISO722xC Input Voltage Low-to-High Switching Threshold vs Free-Air Temperature

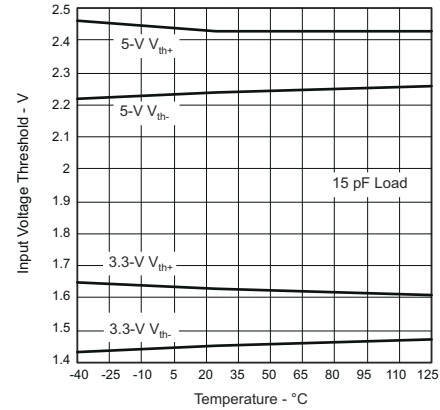

Figure 6-9. ISO722xM Input Voltage High-to-Low vs Free-Air Temperature

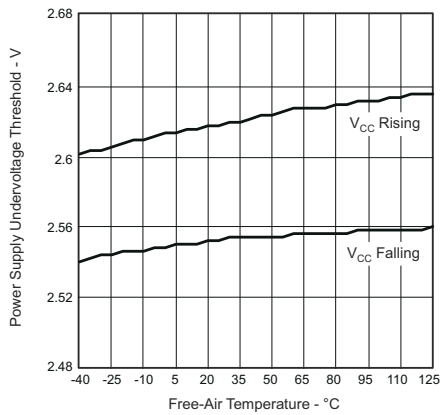

Figure 6-10. V_{CC} Undervoltage Threshold vs Free-Air Temperature

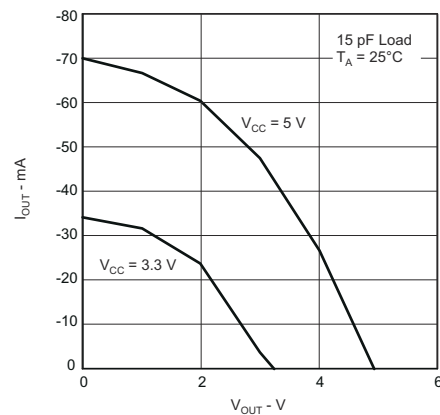

Figure 6-11. High-Level Output Current vs High-Level Output Voltage

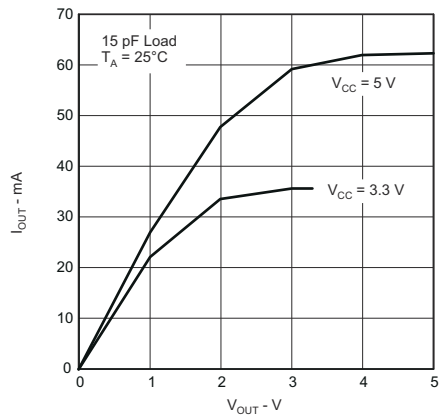

Figure 6-12. Low-Level Output Current vs Low-Level Output Voltage

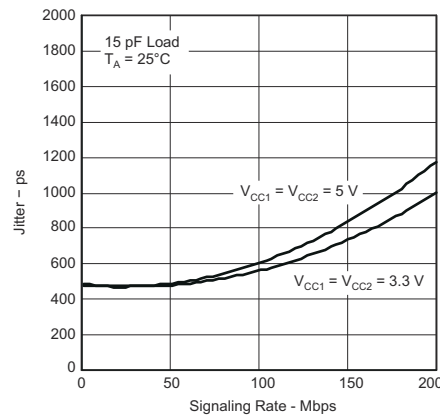
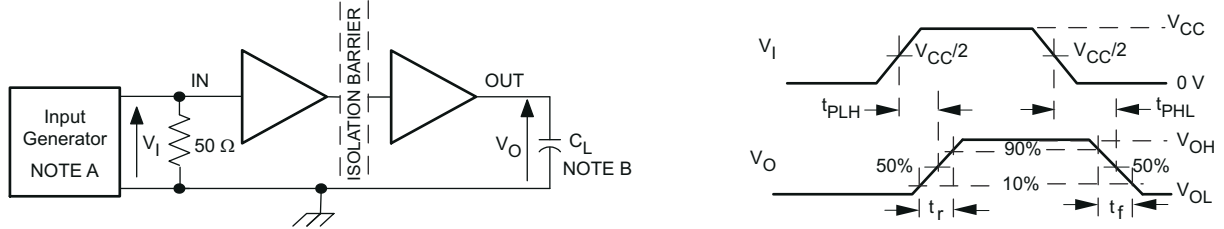

Figure 6-13. ISO722xM Jitter vs Signaling Rate

7 Parameter Measurement Information



- A. The input pulse is supplied by a generator having the following characteristics: PRR \leq 50 kHz, 50% duty cycle, $t_r \leq 3$ ns, $t_f \leq 3$ ns, $Z_0 = 50 \Omega$.
- B. $C_L = 15$ pF and includes instrumentation and fixture capacitance within $\pm 20\%$.

Figure 7-1. Switching Characteristic Test Circuit and Voltage Waveforms

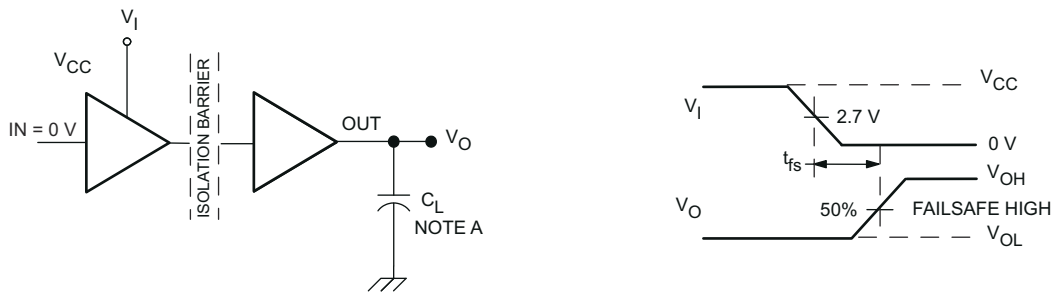

- A. $C_L = 15$ pF and includes instrumentation and fixture capacitance within $\pm 20\%$.

Figure 7-2. Failsafe Delay Time Test Circuit and Voltage Waveforms

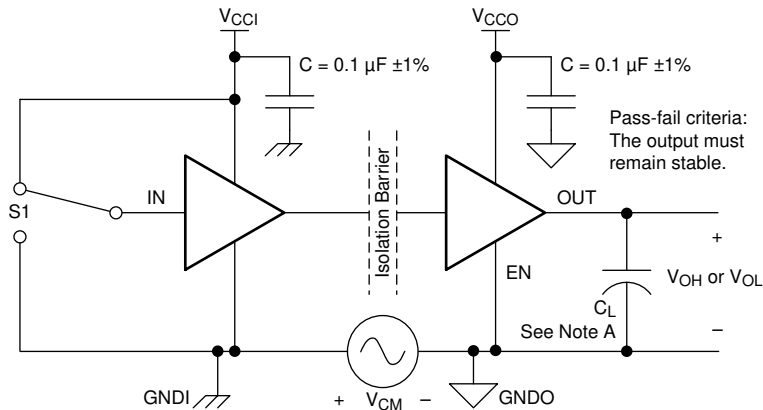

Copyright © 2016, Texas Instruments Incorporated

- A. $C_L = 15$ pF and includes instrumentation and fixture capacitance within $\pm 20\%$.

Figure 7-3. Common-Mode Transient Immunity Test Circuit

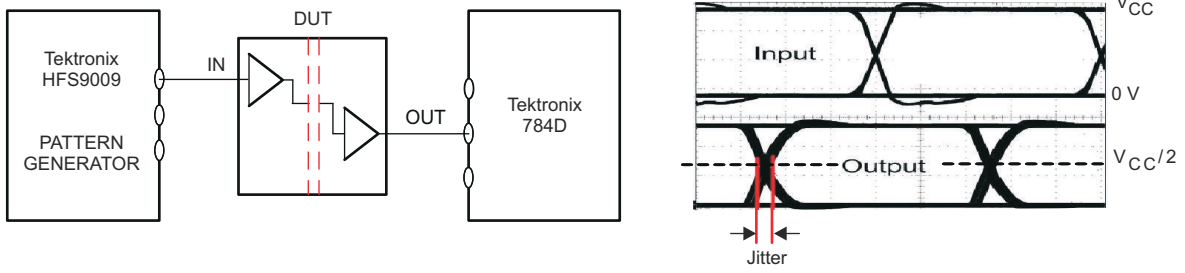

PRBS bit pattern run length is $2^{16} - 1$. Transition time is 800 ps.

Figure 7-4. Peak-to-Peak Eye-Pattern Jitter Test Circuit and Voltage Waveform

8 Detailed Description

8.1 Overview

The isolator in the [Section 8.2](#) is based on a capacitive isolation barrier technique. The I/O channel of the ISO7220x and ISO7221x family of devices consists of two internal data channels, a high-frequency channel (HF) with a bandwidth from 100 kbps up to 150 Mbps, and a low-frequency channel (LF) covering the range from 100 kbps down to DC. In principle, a single-ended input signal entering the HF-channel is split into a differential signal via the inverter gate at the input. The following capacitor-resistor networks differentiate the signal into transients, which then are converted into differential pulses by two comparators. The comparator outputs drive a NOR-gate flip-flop whose output feeds an output multiplexer. A decision logic (DCL) at the driving output of the flip-flop measures the durations between signal transients. If the duration between two consecutive transients exceeds a certain time limit, (as in the case of a low-frequency signal), the DCL forces the output-multiplexer to switch from the high-frequency to the low-frequency channel.

Because low-frequency input signals require the internal capacitors to assume prohibitively large values, these signals are pulse-width modulated (PWM) with the carrier frequency of an internal oscillator, thus creating a sufficiently high frequency signal, capable of passing the capacitive barrier. As the input is modulated, a low-pass filter (LPF) is needed to remove the high-frequency carrier from the actual data before passing it on to the output multiplexer.

8.2 Functional Block Diagram

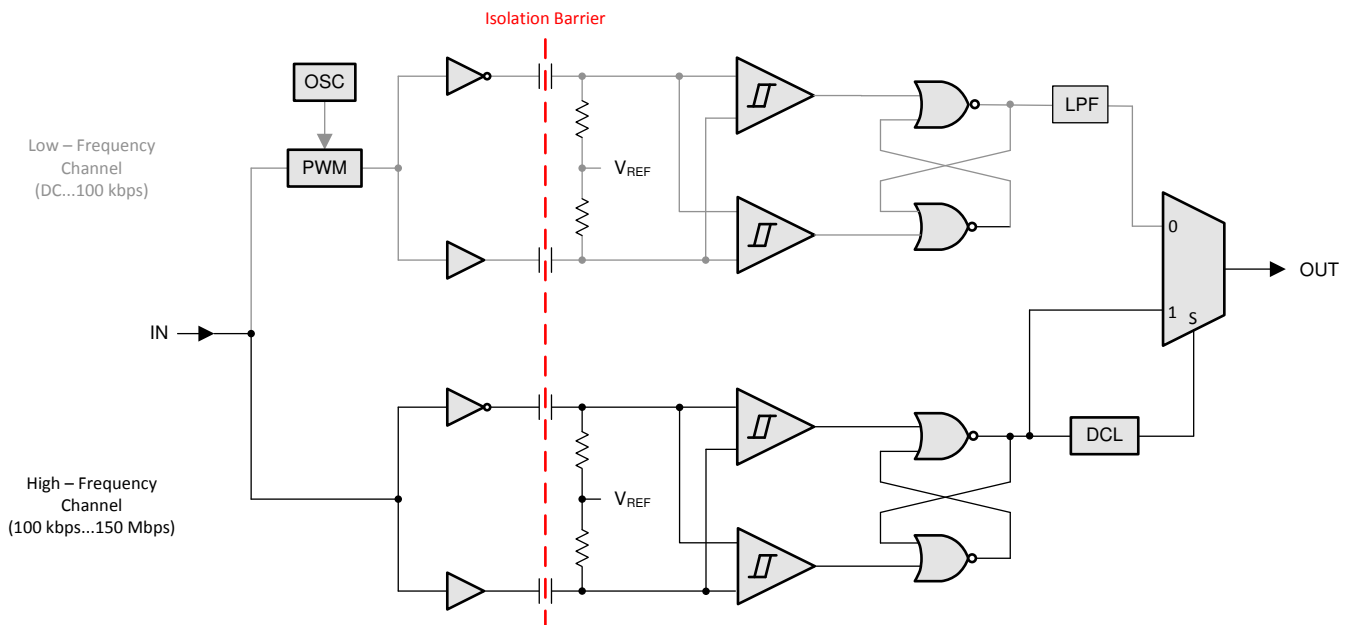

Copyright © 2016, Texas Instruments Incorporated

8.3 Feature Description

Table 8-1 provides an overview of the device features.

Table 8-1. Device Features

PART NUMBER	MAXIMUM SIGNALING RATE	INPUT THRESHOLD	CHANNEL DIRECTION
ISO7220A	1 Mbps	≈ 1.5 V (TTL) (CMOS compatible)	Same direction
ISO7220B	5 Mbps	≈ 1.5 V (TTL) (CMOS compatible)	
ISO7220C	25 Mbps	≈ 1.5 V (TTL) (CMOS compatible)	
ISO7220M	150 Mbps	$V_{CC}/2$ (CMOS)	
ISO7221A	1 Mbps	≈ 1.5 V (TTL) (CMOS compatible)	Opposite directions
ISO7221B	5 Mbps	≈ 1.5 V (TTL) (CMOS compatible)	
ISO7221C	25 Mbps	≈ 1.5 V (TTL) (CMOS compatible)	
ISO7221M	150 Mbps	$V_{CC}/2$ (CMOS)	

8.4 Device Functional Modes

The ISO7220x and ISO7221x family of devices functional modes are listed in Table 8-2.

Table 8-2. ISO7220x or ISO7221x Function Table (1)

INPUT SIDE V_{CC}	OUTPUT SIDE V_{CC}	INPUT (IN)	OUTPUT (OUT)
PU	PU	H	H
		L	L
		Open	H
PD	PU	X	H
X	PD	X	Undetermined

- (1) PU = Powered Up ($V_{CC} \geq 3.0$ V), PD = Powered Down ($V_{CC} \leq 2.5$ V), X = Irrelevant, H = High Level, L = Low Level

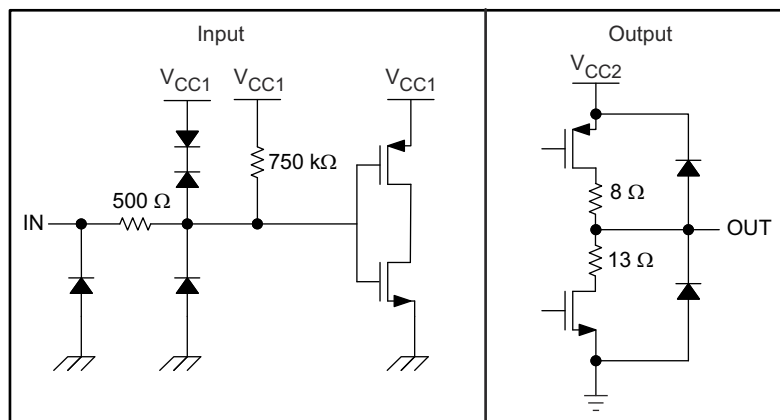

Figure 8-1. Device I/O Schematics

9 Application and Implementation

Note

Information in the following applications sections is not part of the TI component specification, and TI does not warrant its accuracy or completeness. TI's customers are responsible for determining suitability of components for their purposes, as well as validating and testing their design implementation to confirm system functionality.

9.1 Application Information

The ISO7220x and ISO7221x family devices use single-ended TTL or CMOS-logic switching technology. The supply voltage range is from 3 V (2.8 V for C-grade) to 5.5 V for both supplies, V_{CC1} and V_{CC2} . When designing with digital isolators, because of the single-ended design structure, digital isolators do not conform to any specific interface standard and are only intended for isolating single-ended CMOS or TTL digital signal lines. The isolator is typically placed between the data controller (that is, μC or UART), and a data converter or a line transceiver, regardless of the interface type or standard.

9.2 Typical Application

The ISO7221x family of devices can be used with Texas Instruments' mixed signal micro-controller, digital-to-analog converter, transformer driver, and voltage regulator to create an isolated 4- to 20-mA current loop.

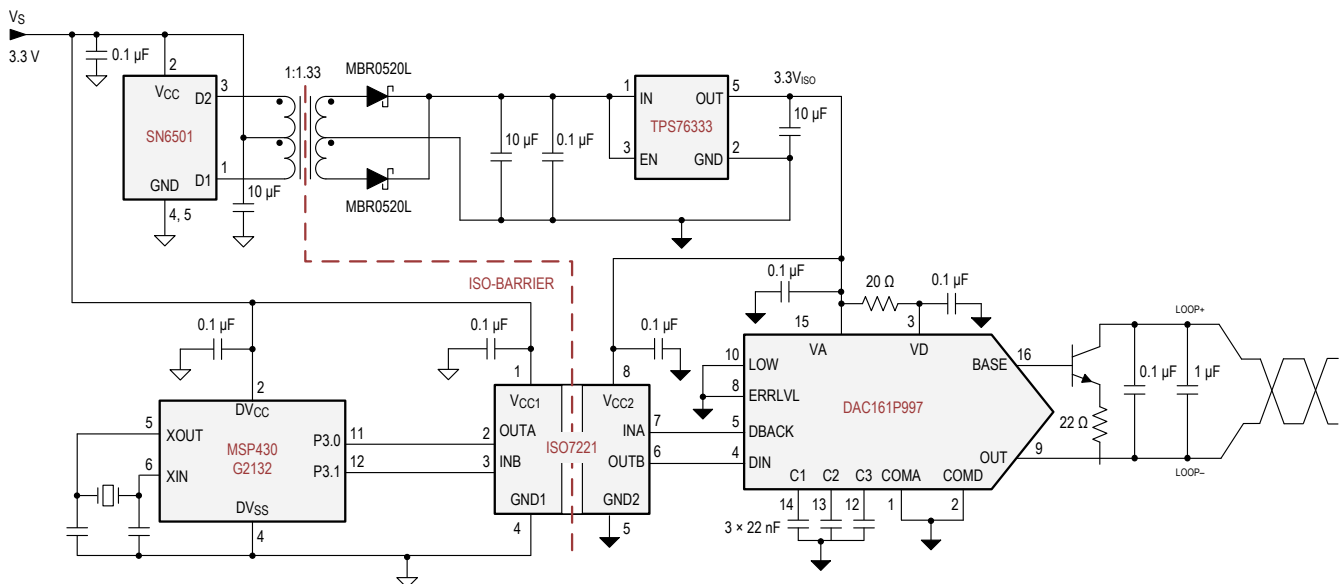

Figure 9-1. Isolated 4- to 20-mA Current Loop

9.2.1 Design Requirements

Unlike optocouplers, which require external components to improve performance, provide bias (or limit current), the ISO7220x and ISO7221x devices require only two external bypass capacitors to operate.

9.2.2 Detailed Design Procedure

Figure 9-2 and Figure 9-3 show the hookup of a typical ISO7220x and ISO7221x circuit. The only external components are two bypass capacitors.

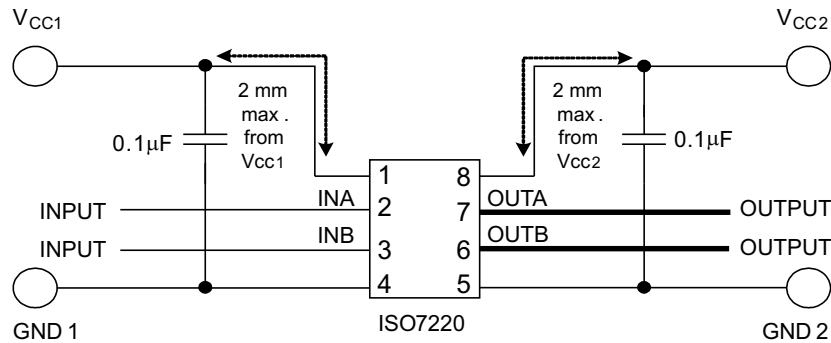

Figure 9-2. Typical ISO7220x Circuit Hook-Up

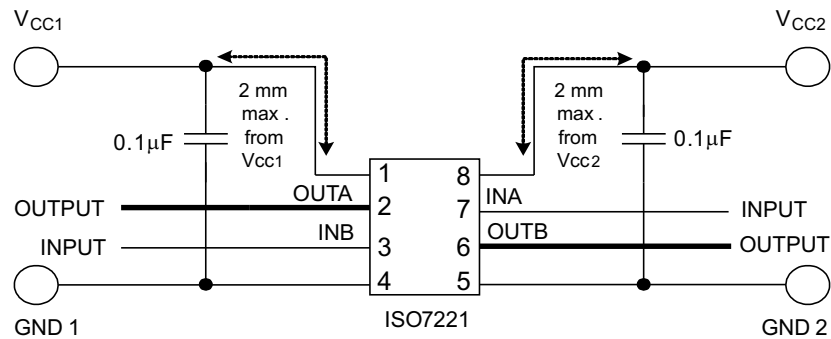

Figure 9-3. Typical ISO7221x Circuit Hook-Up

9.2.3 Application Curve

At maximum working voltage, the isolation barrier of the ISO7220x and ISO7221x family of devices has more than 28 years of life.

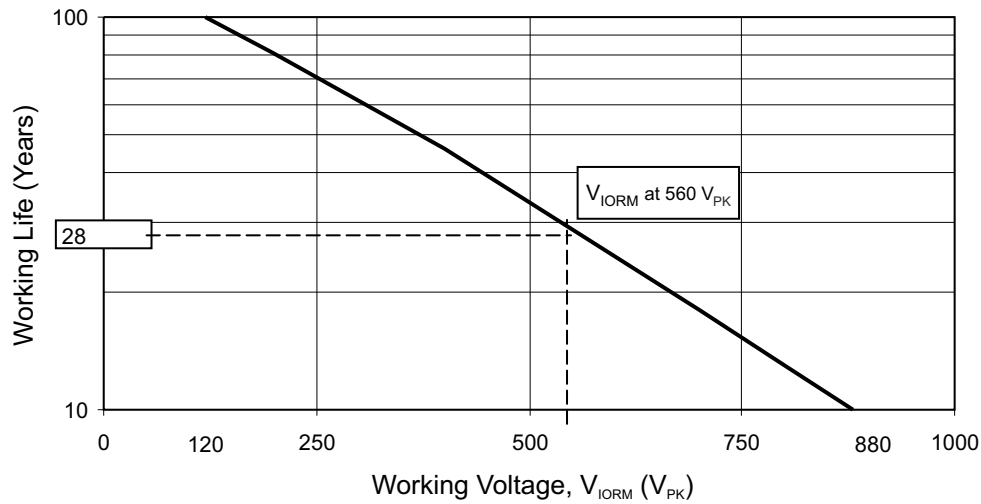

Figure 9-4. Time-Dependent Dielectric Breakdown Test Results

10 Power Supply Recommendations

To help ensure reliable operation at all data rates and supply voltages, a 0.1- μ F bypass capacitor is recommended at input and output supply pins (V_{CC1} and V_{CC2}). The capacitors should be placed as close to the supply pins as possible. If only a single primary-side power supply is available in an application, isolated power can be generated for the secondary-side with the help of a transformer driver such as Texas Instruments SN6501 device. For such applications, detailed power supply design and transformer selection recommendations are available in [SN6501 Transformer Driver for Isolated Power Supplies](#).

11 Layout

11.1 Layout Guidelines

A minimum of four layers are required to accomplish a low EMI PCB design (see [Figure 11-1](#)). Layer stacking should be in the following order (top-to-bottom): high-speed signal layer, ground plane, power plane and low-frequency signal layer.

- Route the high-speed traces on the top layer to avoid the use of vias (and the introduction of the inductances) and allow for clean interconnects between the isolator and the transmitter and receiver circuits of the data link.
- Place a solid ground plane next to the high-speed signal layer to establish controlled impedance for transmission line interconnects and provide an excellent low-inductance path for the return current flow.
- Place the power plane next to the ground plane to create additional high-frequency bypass capacitance of approximately 100 pF/in².
- Route the slower speed control signals on the bottom layer to allow for greater flexibility as these signal links usually have margin to tolerate discontinuities such as vias.

If an additional supply voltage plane or signal layer is needed, add a second power or ground plane system to the stack to keep it symmetrical. Adding a second plane system to the stack makes the stack mechanically stable and prevents it from warping. The power and ground plane of each power system can be placed closer together, thus increasing the high-frequency bypass capacitance significantly.

For detailed layout recommendations, refer to the [Digital Isolator Design Guide](#).

11.1.1 PCB Material

For digital circuit boards operating at less than 150 Mbps, (or rise and fall times greater than 1 ns), and trace lengths of up to 10 inches, use standard FR-4 UL94V-0 printed circuit board. This PCB is preferred over cheaper alternatives because of lower dielectric losses at high frequencies, less moisture absorption, greater strength and stiffness, and the self-extinguishing flammability-characteristics.

11.2 Layout Example

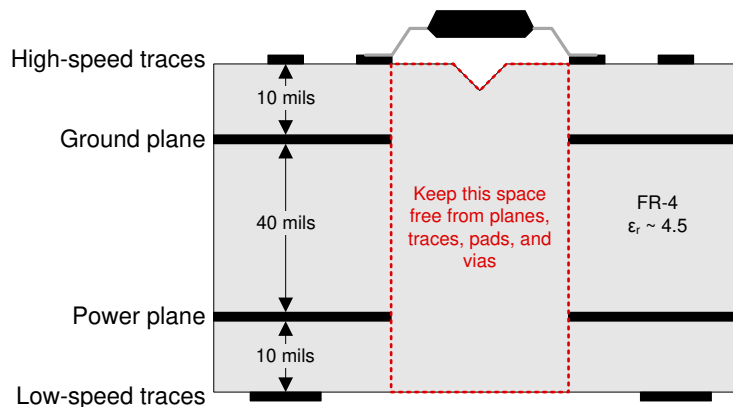

Figure 11-1. Recommended Layer Stack

12 Device and Documentation Support

12.1 Device Support

12.1.1 Development Support

For development support, refer to:

- [AC-mains LED Lighting with DALI DMX512 & Power Line Communications Reference Design](#)
- [Industrial Servo Drive and AC Inverter Drive Reference Design](#)
- [Low-Cost Single/Dual-Phase Isolated Electricity Measurement Reference Design](#)
- [Noise Tolerant Capacitive Touch HMI Reference Design](#)
- [Type 2 PoE PSE, 6kV Lightning Surge Reference Design](#)

12.2 Documentation Support

12.2.1 Related Documentation

For related documentation, see the following:

- Texas Instruments, [DAC161P997 Single-Wire 16-bit DAC for 4- to 20-mA Loops data sheet](#)
- Texas Instruments, [Digital Isolator Design Guide](#)
- Texas Instruments, [High-Voltage Lifetime of the ISO72x Family of Digital Isolators application report](#)
- Texas Instruments, [Isolation Glossary](#)
- Texas Instruments, [MSP430G2x32 Mixed Signal Microcontroller data sheet](#)
- Texas Instruments, [SN6501 Transformer Driver for Isolated Power Supplies data sheet](#)
- Texas Instruments, [TPS763xx Low-Power 150-mA Low-Dropout Linear Regulators data sheet](#)

12.3 Related Links

The table below lists quick access links. Categories include technical documents, support and community resources, tools and software, and quick access to sample or buy.

Table 12-1. Related Links

PARTS	PRODUCT FOLDER	ORDER NOW	TECHNICAL DOCUMENTS	TOOLS & SOFTWARE	SUPPORT & COMMUNITY
ISO7220A	Click here	Click here	Click here	Click here	Click here
ISO7220B	Click here	Click here	Click here	Click here	Click here
ISO7220C	Click here	Click here	Click here	Click here	Click here
ISO7220M	Click here	Click here	Click here	Click here	Click here
ISO7221A	Click here	Click here	Click here	Click here	Click here
ISO7221B	Click here	Click here	Click here	Click here	Click here
ISO7221C	Click here	Click here	Click here	Click here	Click here
ISO7221M	Click here	Click here	Click here	Click here	Click here

12.4 Receiving Notification of Documentation Updates

To receive notification of documentation updates, navigate to the device product folder on ti.com. Click on *Subscribe to updates* to register and receive a weekly digest of any product information that has changed. For change details, review the revision history included in any revised document.

12.5 Support Resources

[TI E2E™ support forums](#) are an engineer's go-to source for fast, verified answers and design help — straight from the experts. Search existing answers or ask your own question to get the quick design help you need.

Linked content is provided "AS IS" by the respective contributors. They do not constitute TI specifications and do not necessarily reflect TI's views; see TI's [Terms of Use](#).

12.6 Trademarks

Profibus™ is a trademark of Profibus.

DeviceNet™ is a trademark of Open DeviceNet Vendors Association.

TI E2E™ is a trademark of Texas Instruments.

All trademarks are the property of their respective owners.

12.7 Electrostatic Discharge Caution



This integrated circuit can be damaged by ESD. Texas Instruments recommends that all integrated circuits be handled with appropriate precautions. Failure to observe proper handling and installation procedures can cause damage.

ESD damage can range from subtle performance degradation to complete device failure. Precision integrated circuits may be more susceptible to damage because very small parametric changes could cause the device not to meet its published specifications.

12.8 Glossary

[TI Glossary](#) This glossary lists and explains terms, acronyms, and definitions.

13 Mechanical, Packaging, and Orderable Information

The following pages include mechanical, packaging, and orderable information. This information is the most current data available for the designated devices. This data is subject to change without notice and revision of this document. For browser-based versions of this data sheet, refer to the left-hand navigation.



D0008B

PACKAGE OUTLINE
SOIC - 1.75 mm max height

SMALL OUTLINE INTEGRATED CIRCUIT

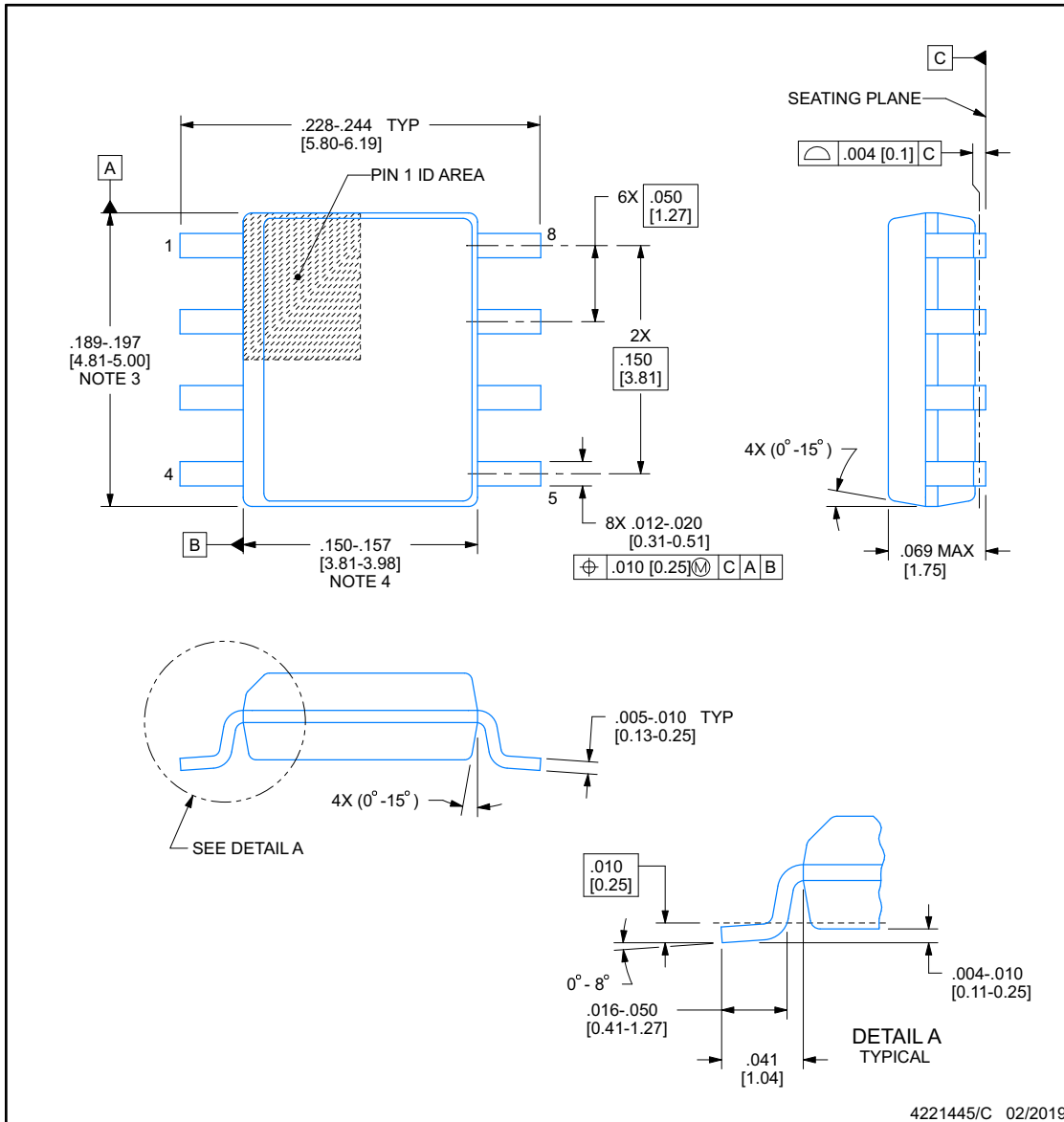

NOTES:

1. Linear dimensions are in inches [millimeters]. Dimensions in parenthesis are for reference only. Controlling dimensions are in inches. Dimensioning and tolerancing per ASME Y14.5M.
2. This drawing is subject to change without notice.
3. This dimension does not include mold flash, protrusions, or gate burrs. Mold flash, protrusions, or gate burrs shall not exceed $.006$ [0.15], per side.
4. This dimension does not include interlead flash.
5. Reference JEDEC registration MS-012, variation AA.

EXAMPLE BOARD LAYOUT

D0008B

SOIC - 1.75 mm max height

SMALL OUTLINE INTEGRATED CIRCUIT

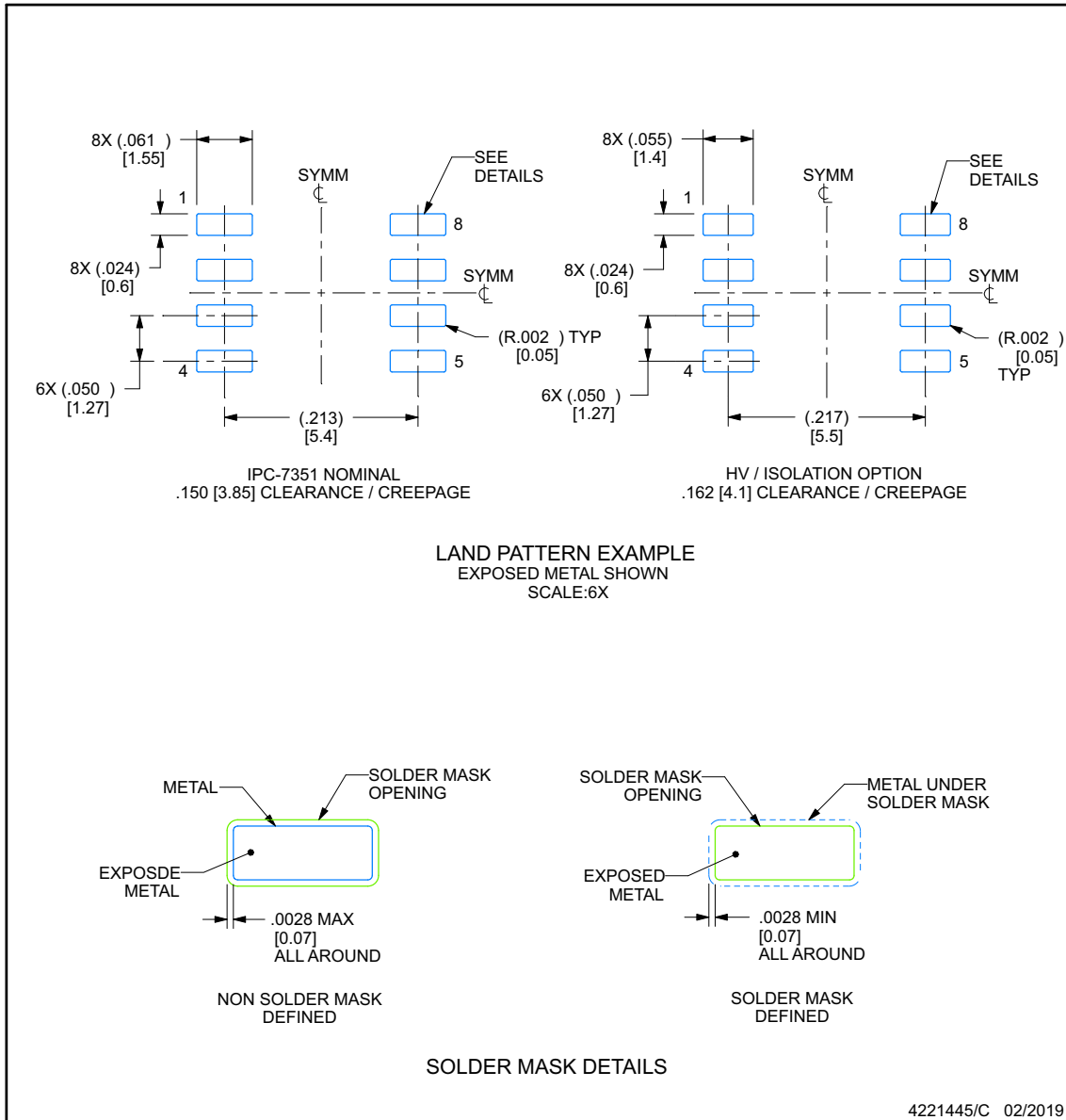

NOTES: (continued)

- Publication IPC-7351 may have alternate designs.
- Solder mask tolerances between and around signal pads can vary based on board fabrication site.

EXAMPLE STENCIL DESIGN

D0008B

SOIC - 1.75 mm max height

SMALL OUTLINE INTEGRATED CIRCUIT

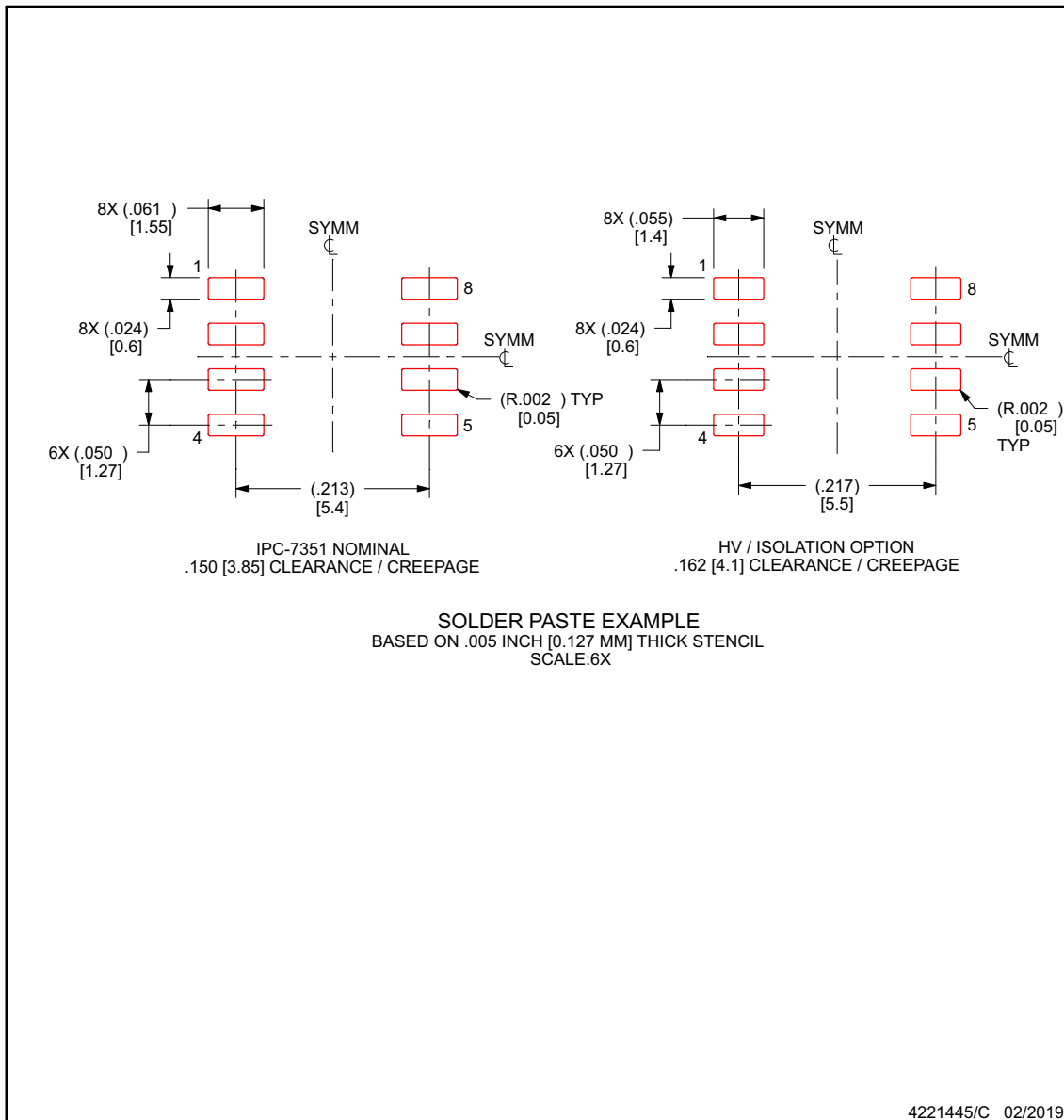

NOTES: (continued)

8. Laser cutting apertures with trapezoidal walls and rounded corners may offer better paste release. IPC-7525 may have alternate design recommendations.
9. Board assembly site may have different recommendations for stencil design.

PACKAGING INFORMATION

Orderable Device	Status (1)	Package Type	Package Drawing	Pins	Package Qty	Eco Plan (2)	Lead finish/ Ball material (6)	MSL Peak Temp (3)	Op Temp (°C)	Device Marking (4/5)	Samples
ISO7220AD	LIFEBUY	SOIC	D	8	75	RoHS & Green	NIPDAU	Level-1-260C-UNLIM	-40 to 125	I7220A	
ISO7220ADG4	LIFEBUY	SOIC	D	8	75	RoHS & Green	NIPDAU	Level-1-260C-UNLIM	-40 to 125	I7220A	
ISO7220ADR	ACTIVE	SOIC	D	8	2500	RoHS & Green	NIPDAU	Level-1-260C-UNLIM	-40 to 125	I7220A	Samples
ISO7220ADRG4	ACTIVE	SOIC	D	8	2500	RoHS & Green	NIPDAU	Level-1-260C-UNLIM	-40 to 125	I7220A	Samples
ISO7220BD	LIFEBUY	SOIC	D	8	75	RoHS & Green	NIPDAU	Level-1-260C-UNLIM	-40 to 125	I7220B	
ISO7220BDG4	LIFEBUY	SOIC	D	8	75	RoHS & Green	NIPDAU	Level-1-260C-UNLIM	-40 to 125	I7220B	
ISO7220BDR	ACTIVE	SOIC	D	8	2500	RoHS & Green	NIPDAU	Level-1-260C-UNLIM	-40 to 125	I7220B	Samples
ISO7220CD	LIFEBUY	SOIC	D	8	75	RoHS & Green	NIPDAU	Level-1-260C-UNLIM	-40 to 125	I7220C	
ISO7220CDR	ACTIVE	SOIC	D	8	2500	RoHS & Green	NIPDAU	Level-1-260C-UNLIM	-40 to 125	I7220C	Samples
ISO7220MD	LIFEBUY	SOIC	D	8	75	RoHS & Green	NIPDAU	Level-1-260C-UNLIM	-40 to 125	I7220M	
ISO7220MDG4	LIFEBUY	SOIC	D	8	75	RoHS & Green	NIPDAU	Level-1-260C-UNLIM	-40 to 125	I7220M	
ISO7220MDR	ACTIVE	SOIC	D	8	2500	RoHS & Green	NIPDAU	Level-1-260C-UNLIM	-40 to 125	I7220M	Samples
ISO7220MDRG4	ACTIVE	SOIC	D	8	2500	RoHS & Green	NIPDAU	Level-1-260C-UNLIM	-40 to 125	I7220M	Samples
ISO7221AD	LIFEBUY	SOIC	D	8	75	RoHS & Green	NIPDAU	Level-1-260C-UNLIM	-40 to 125	I7221A	
ISO7221ADG4	LIFEBUY	SOIC	D	8	75	RoHS & Green	NIPDAU	Level-1-260C-UNLIM	-40 to 125	I7221A	
ISO7221ADR	ACTIVE	SOIC	D	8	2500	RoHS & Green	NIPDAU	Level-1-260C-UNLIM	-40 to 125	I7221A	Samples
ISO7221ADRG4	ACTIVE	SOIC	D	8	2500	RoHS & Green	NIPDAU	Level-1-260C-UNLIM	-40 to 125	I7221A	Samples
ISO7221BD	LIFEBUY	SOIC	D	8	75	RoHS & Green	NIPDAU	Level-1-260C-UNLIM	-40 to 125	I7221B	
ISO7221BDR	ACTIVE	SOIC	D	8	2500	RoHS & Green	NIPDAU	Level-1-260C-UNLIM	-40 to 125	I7221B	Samples
ISO7221BDRG4	ACTIVE	SOIC	D	8	2500	RoHS & Green	NIPDAU	Level-1-260C-UNLIM	-40 to 125	I7221B	Samples
ISO7221CD	LIFEBUY	SOIC	D	8	75	RoHS & Green	NIPDAU	Level-1-260C-UNLIM	-40 to 125	I7221C	
ISO7221CDG4	LIFEBUY	SOIC	D	8	75	RoHS & Green	NIPDAU	Level-1-260C-UNLIM	-40 to 125	I7221C	
ISO7221CDR	ACTIVE	SOIC	D	8	2500	RoHS & Green	NIPDAU	Level-1-260C-UNLIM	-40 to 125	I7221C	Samples
ISO7221CDRG4	ACTIVE	SOIC	D	8	2500	RoHS & Green	NIPDAU	Level-1-260C-UNLIM	-40 to 125	I7221C	Samples

Orderable Device	Status (1)	Package Type	Package Drawing	Pins	Package Qty	Eco Plan (2)	Lead finish/ Ball material (6)	MSL Peak Temp (3)	Op Temp (°C)	Device Marking (4/5)	Samples
ISO7221MD	LIFEBUY	SOIC	D	8	75	RoHS & Green	NIPDAU	Level-1-260C-UNLIM	-40 to 125	I7221M	
ISO7221MDR	ACTIVE	SOIC	D	8	2500	RoHS & Green	NIPDAU	Level-1-260C-UNLIM	-40 to 125	I7221M	Samples

(1) The marketing status values are defined as follows:

ACTIVE: Product device recommended for new designs.

LIFEBUY: TI has announced that the device will be discontinued, and a lifetime-buy period is in effect.

NRND: Not recommended for new designs. Device is in production to support existing customers, but TI does not recommend using this part in a new design.

PREVIEW: Device has been announced but is not in production. Samples may or may not be available.

OBSOLETE: TI has discontinued the production of the device.

(2) **RoHS:** TI defines "RoHS" to mean semiconductor products that are compliant with the current EU RoHS requirements for all 10 RoHS substances, including the requirement that RoHS substance do not exceed 0.1% by weight in homogeneous materials. Where designed to be soldered at high temperatures, "RoHS" products are suitable for use in specified lead-free processes. TI may reference these types of products as "Pb-Free".

RoHS Exempt: TI defines "RoHS Exempt" to mean products that contain lead but are compliant with EU RoHS pursuant to a specific EU RoHS exemption.

Green: TI defines "Green" to mean the content of Chlorine (Cl) and Bromine (Br) based flame retardants meet JS709B low halogen requirements of <=1000ppm threshold. Antimony trioxide based flame retardants must also meet the <=1000ppm threshold requirement.

(3) MSL, Peak Temp. - The Moisture Sensitivity Level rating according to the JEDEC industry standard classifications, and peak solder temperature.

(4) There may be additional marking, which relates to the logo, the lot trace code information, or the environmental category on the device.

(5) Multiple Device Markings will be inside parentheses. Only one Device Marking contained in parentheses and separated by a "~" will appear on a device. If a line is indented then it is a continuation of the previous line and the two combined represent the entire Device Marking for that device.

(6) Lead finish/Ball material - Orderable Devices may have multiple material finish options. Finish options are separated by a vertical ruled line. Lead finish/Ball material values may wrap to two lines if the finish value exceeds the maximum column width.

Important Information and Disclaimer:The information provided on this page represents TI's knowledge and belief as of the date that it is provided. TI bases its knowledge and belief on information provided by third parties, and makes no representation or warranty as to the accuracy of such information. Efforts are underway to better integrate information from third parties. TI has taken and continues to take reasonable steps to provide representative and accurate information but may not have conducted destructive testing or chemical analysis on incoming materials and chemicals. TI and TI suppliers consider certain information to be proprietary, and thus CAS numbers and other limited information may not be available for release.

In no event shall TI's liability arising out of such information exceed the total purchase price of the TI part(s) at issue in this document sold by TI to Customer on an annual basis.

OTHER QUALIFIED VERSIONS OF ISO7220A, ISO7221A, ISO7221C :

- Automotive : [ISO7220A-Q1](#), [ISO7221A-Q1](#), [ISO7221C-Q1](#)

NOTE: Qualified Version Definitions:

- Automotive - Q100 devices qualified for high-reliability automotive applications targeting zero defects

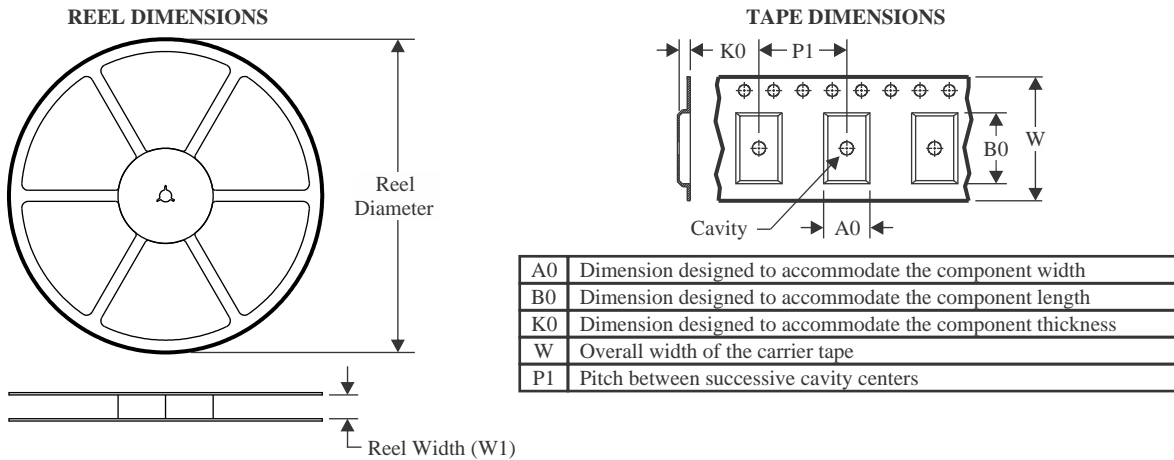
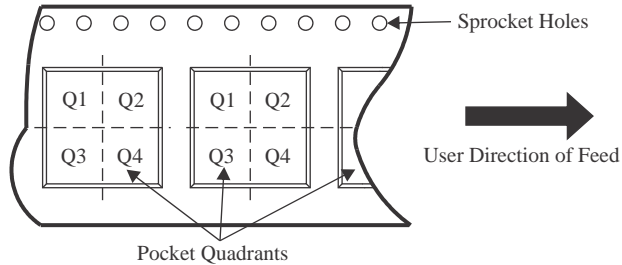
TAPE AND REEL INFORMATION

QUADRANT ASSIGNMENTS FOR PIN 1 ORIENTATION IN TAPE

*All dimensions are nominal

Device	Package Type	Package Drawing	Pins	SPQ	Reel Diameter (mm)	Reel Width W1 (mm)	A0 (mm)	B0 (mm)	K0 (mm)	P1 (mm)	W (mm)	Pin1 Quadrant
ISO7220ADR	SOIC	D	8	2500	330.0	12.4	6.4	5.2	2.1	8.0	12.0	Q1
ISO7220BDR	SOIC	D	8	2500	330.0	12.4	6.4	5.2	2.1	8.0	12.0	Q1
ISO7220CDR	SOIC	D	8	2500	330.0	12.4	6.4	5.2	2.1	8.0	12.0	Q1
ISO7220MDR	SOIC	D	8	2500	330.0	12.4	6.4	5.2	2.1	8.0	12.0	Q1
ISO7221ADR	SOIC	D	8	2500	330.0	12.4	6.4	5.2	2.1	8.0	12.0	Q1
ISO7221BDR	SOIC	D	8	2500	330.0	12.4	6.4	5.2	2.1	8.0	12.0	Q1
ISO7221CDR	SOIC	D	8	2500	330.0	12.4	6.4	5.2	2.1	8.0	12.0	Q1
ISO7221MDR	SOIC	D	8	2500	330.0	12.4	6.4	5.2	2.1	8.0	12.0	Q1

TAPE AND REEL BOX DIMENSIONS

*All dimensions are nominal

Device	Package Type	Package Drawing	Pins	SPQ	Length (mm)	Width (mm)	Height (mm)
ISO7220ADR	SOIC	D	8	2500	350.0	350.0	43.0
ISO7220BDR	SOIC	D	8	2500	350.0	350.0	43.0
ISO7220CDR	SOIC	D	8	2500	350.0	350.0	43.0
ISO7220MDR	SOIC	D	8	2500	350.0	350.0	43.0
ISO7221ADR	SOIC	D	8	2500	350.0	350.0	43.0
ISO7221BDR	SOIC	D	8	2500	350.0	350.0	43.0
ISO7221CDR	SOIC	D	8	2500	350.0	350.0	43.0
ISO7221MDR	SOIC	D	8	2500	350.0	350.0	43.0

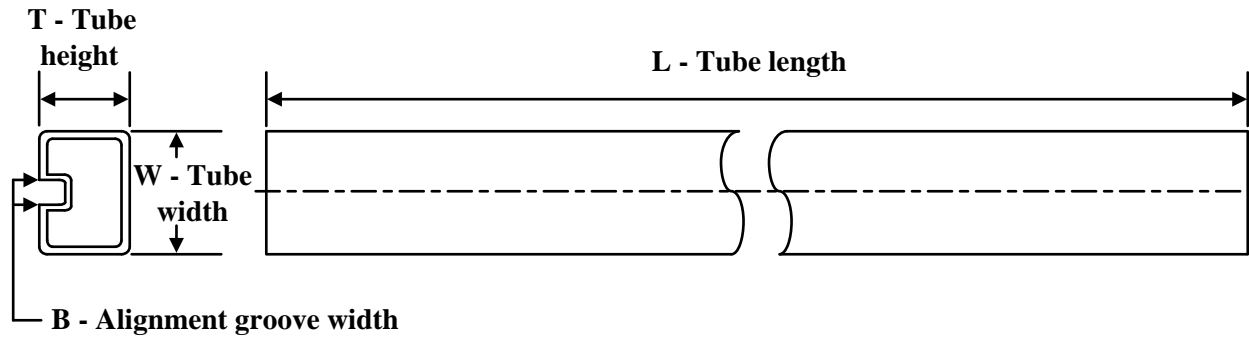
TUBE

*All dimensions are nominal

Device	Package Name	Package Type	Pins	SPQ	L (mm)	W (mm)	T (μm)	B (mm)
ISO7220AD	D	SOIC	8	75	505.46	6.76	3810	4
ISO7220ADG4	D	SOIC	8	75	505.46	6.76	3810	4
ISO7220BD	D	SOIC	8	75	505.46	6.76	3810	4
ISO7220BDG4	D	SOIC	8	75	505.46	6.76	3810	4
ISO7220CD	D	SOIC	8	75	505.46	6.76	3810	4
ISO7220MD	D	SOIC	8	75	505.46	6.76	3810	4
ISO7220MDG4	D	SOIC	8	75	505.46	6.76	3810	4
ISO7221AD	D	SOIC	8	75	505.46	6.76	3810	4
ISO7221ADG4	D	SOIC	8	75	505.46	6.76	3810	4
ISO7221BD	D	SOIC	8	75	505.46	6.76	3810	4
ISO7221CD	D	SOIC	8	75	505.46	6.76	3810	4
ISO7221CDG4	D	SOIC	8	75	505.46	6.76	3810	4
ISO7221MD	D	SOIC	8	75	505.46	6.76	3810	4



D0008A

PACKAGE OUTLINE

SOIC - 1.75 mm max height

SMALL OUTLINE INTEGRATED CIRCUIT



4214825/C 02/2019

NOTES:

1. Linear dimensions are in inches [millimeters]. Dimensions in parenthesis are for reference only. Controlling dimensions are in inches. Dimensioning and tolerancing per ASME Y14.5M.
2. This drawing is subject to change without notice.
3. This dimension does not include mold flash, protrusions, or gate burrs. Mold flash, protrusions, or gate burrs shall not exceed $.006$ [0.15] per side.
4. This dimension does not include interlead flash.
5. Reference JEDEC registration MS-012, variation AA.

EXAMPLE BOARD LAYOUT

D0008A

SOIC - 1.75 mm max height

SMALL OUTLINE INTEGRATED CIRCUIT



LAND PATTERN EXAMPLE
EXPOSED METAL SHOWN
SCALE:8X



SOLDER MASK DETAILS

4214825/C 02/2019

NOTES: (continued)

6. Publication IPC-7351 may have alternate designs.

7. Solder mask tolerances between and around signal pads can vary based on board fabrication site.

EXAMPLE STENCIL DESIGN

D0008A

SOIC - 1.75 mm max height

SMALL OUTLINE INTEGRATED CIRCUIT



SOLDER PASTE EXAMPLE
BASED ON .005 INCH [0.125 MM] THICK STENCIL
SCALE:8X

4214825/C 02/2019

NOTES: (continued)

8. Laser cutting apertures with trapezoidal walls and rounded corners may offer better paste release. IPC-7525 may have alternate design recommendations.
9. Board assembly site may have different recommendations for stencil design.

IMPORTANT NOTICE AND DISCLAIMER

TI PROVIDES TECHNICAL AND RELIABILITY DATA (INCLUDING DATA SHEETS), DESIGN RESOURCES (INCLUDING REFERENCE DESIGNS), APPLICATION OR OTHER DESIGN ADVICE, WEB TOOLS, SAFETY INFORMATION, AND OTHER RESOURCES "AS IS" AND WITH ALL FAULTS, AND DISCLAIMS ALL WARRANTIES, EXPRESS AND IMPLIED, INCLUDING WITHOUT LIMITATION ANY IMPLIED WARRANTIES OF MERCHANTABILITY, FITNESS FOR A PARTICULAR PURPOSE OR NON-INFRINGEMENT OF THIRD PARTY INTELLECTUAL PROPERTY RIGHTS.

These resources are intended for skilled developers designing with TI products. You are solely responsible for (1) selecting the appropriate TI products for your application, (2) designing, validating and testing your application, and (3) ensuring your application meets applicable standards, and any other safety, security, regulatory or other requirements.

These resources are subject to change without notice. TI grants you permission to use these resources only for development of an application that uses the TI products described in the resource. Other reproduction and display of these resources is prohibited. No license is granted to any other TI intellectual property right or to any third party intellectual property right. TI disclaims responsibility for, and you will fully indemnify TI and its representatives against, any claims, damages, costs, losses, and liabilities arising out of your use of these resources.

TI's products are provided subject to [TI's Terms of Sale](#) or other applicable terms available either on [ti.com](https://www.ti.com) or provided in conjunction with such TI products. TI's provision of these resources does not expand or otherwise alter TI's applicable warranties or warranty disclaimers for TI products.

TI objects to and rejects any additional or different terms you may have proposed.

Mailing Address: Texas Instruments, Post Office Box 655303, Dallas, Texas 75265
Copyright © 2023, Texas Instruments Incorporated

Looking for pricing, stock, or lifecycle information?

Click below to explore more details on WIN SOURCE:

 [View ISO7221CDR](#) on WIN SOURCE

 [Texas Instruments](#) Information

Optimize Your Supply Chain with WIN SOURCE Solutions

-  Global Sourcing Solution
-  Obsolete Management
-  Cost Control Management
-  Shortage Management
-  Alternative Solution
-  Excess Inventory Management