

BQ77915 3-Series to 5-Series Stackable Ultra-Low Power Primary Protector with Autonomous Cell Balancing and HIBERNATE Mode

1 Features

- Ultra-low quiescent current: 8 μA typ. (NORMAL mode), 2 μA (HIBERNATE mode)
- Full suite of voltage, current, and temperature protections
- Smart passive cell balancing removes cell-to-cell imbalance
- Scalable cell count from 3 series to 20 series or more
- Voltage protection (accuracy ± 10 mV for OV, ± 18 mV for UV)
 - Overvoltage: 3 V to 4.575 V
 - Undervoltage: 1.2 V to 3 V
- Open cell and open-wire detection (OW)
- Current protection
 - Overcurrent discharge 1: -10 mV to -85 mV
 - Overcurrent discharge 2: -20 mV to -170 mV
 - Short-circuit discharge: -40 mV to -340 mV
- Temperature protection
 - Overtemperature charge: 45°C or 50°C
 - Overtemperature discharge: 65°C or 70°C
- Additional features:
 - Independent charge (CHG) and discharge (DSG) FET drivers
 - Smart cell balancing algorithm with integrated FETs (up to 50-mA balancing current), also supports external FETs for higher cell-balancing current
 - Ultra-low power HIBERNATE mode
 - High 36-V absolute maximum rating per cell input
 - Resistor programmable overcurrent (OCD1/2) delay
- SHUTDOWN mode: 0.5- μA maximum
- [Functional Safety-Capable](#)
 - [Documentation available to aid functional safety system design](#)

2 Applications

- [Power tools, garden tools](#)
- [Robotic cleaners, vacuum cleaners, hoverboards](#)
- [e-bikes](#)
- [10.8-V to 72-V packs](#)

3 Description

The BQ77915 device is a low-power battery pack protector that implements a suite of voltage, current, and temperature protections and a smart cell balancing algorithm without microcontroller (MCU) control. The device's stackable interface provides simple scaling to support battery cell applications from 3 series to 20 series or more. Protection thresholds and delays are factory-programmed and available in a variety of configurations. Separate overtemperature and undertemperature thresholds for discharge (OTD and UTD) and charge (OTC and UTC) provide additional flexibility.

Device Information

Part Number ⁽¹⁾	Package	Body Size (NOM)
BQ77915	TSSOP-24	7.70 mm \times 4.40 mm

- (1) For all available packages, see the orderable addendum at the end of the data sheet.

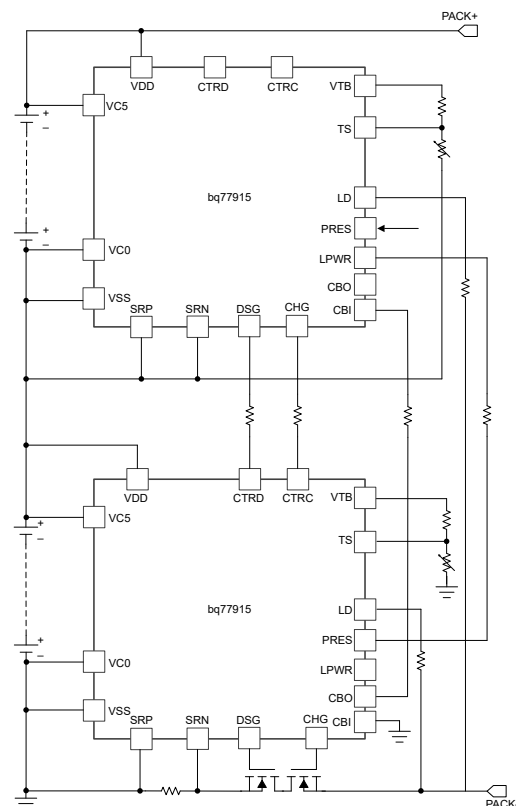

Simplified Schematic



Table of Contents

1 Features	1	9.4 Device Functional Modes.....	31
2 Applications	1	10 Application and Implementation	33
3 Description	1	10.1 Application Information.....	33
4 Revision History	2	10.2 Typical Application.....	39
5 Description (continued)	3	11 Power Supply Recommendations	44
6 Device Comparison Table	3	12 Layout	45
7 Pin Configuration and Functions	4	12.1 Layout Guidelines.....	45
8 Specifications	5	12.2 Layout Example.....	46
8.1 Absolute Maximum Ratings.....	5	13 Device and Documentation Support	47
8.2 ESD Ratings.....	5	13.1 Third-Party Products Disclaimer.....	47
8.3 Recommended Operating Conditions.....	5	13.2 Documentation Support.....	47
8.4 Thermal Information.....	7	13.3 Receiving Notification of Documentation Updates.....	47
8.5 Electrical Characteristics.....	7	13.4 Support Resources.....	47
8.6 Typical Characteristics.....	11	13.5 Trademarks.....	47
9 Detailed Description	12	13.6 Electrostatic Discharge Caution.....	47
9.1 Overview.....	12	13.7 Glossary.....	47
9.2 Functional Block Diagram.....	14	14 Mechanical, Packaging, and Orderable Information	47
9.3 Feature Description.....	14		

4 Revision History

NOTE: Page numbers for previous revisions may differ from page numbers in the current version.

Changes from Revision K (July 2023) to Revision L (August 2023)	Page
• Updated the data sheet per the latest Texas Instruments standards.....	1

Changes from Revision J (March 2022) to Revision K (July 2023)	Page
• Added the BQ7791514 device to the <i>Device Comparison Table</i>	3

Changes from Revision I (September 2020) to Revision J (March 2022)	Page
• This document was updated to the latest Texas Instruments and industry data sheet standards.....	1
• Added the BQ7791513 device to the <i>Device Comparison Table</i>	3

5 Description (continued)

The BQ77915 device provides pack protection through the integrated independent CHG and DSG low-side NMOS FET drivers, which are disabled through two control pins. These control pins also enable cell protection for higher series (6 series and beyond) in an economical manner. To do this, cascade a higher device CHG and DSG outputs to the immediate lower device control pins. For added flexibility, program the discharge overcurrent protection delays with a resistor connected from the OCDP pin to VSS.

The BQ77915 protector maintains a smart, passive cell-balancing algorithm through integrated FETs for cell balancing currents up to 50 mA. For higher cell-balancing current requirements, connect external FETs. A HIBERNATE mode for shipping and storing the battery packs enables ultra-low power operation.

The BQ77915 protector is for battery packs where no host monitoring is required.

6 Device Comparison Table

Unless otherwise specified, the device has, by default, a state comparator enabled with a 1.875-mV threshold. A filtered fault detection is used by default.

Table 6-1. Device Comparison Table

Part Number	OV			UV				OW	OCD1		OCD2		SCD		OCC
	Threshold (mV)	Delay (s)	Hyst (mV)	Threshold (mV)	Delay (s)	Hyst (mV)	Load Removal Recovery (Y/N)	Current (nA)	Threshold (mV)	Delay (ms)	Threshold (mV)	Delay (ms)	Threshold (mV)	Delay (ms)	Threshold (mV)
BQ7791500	4200	1	200	2900	1	400	Y	100	60	180	60	180	120	0.96	60
BQ7791501	4250	1	200	2800	1	400	Y	100	35	180	60	180	120	0.96	20
BQ7791502	4200	1	200	2900	1	400	Y	100	70	180	70	180	120	0.96	70
BQ7791504	4275	1	100	2000	1	200	N	Disabled							
BQ7791506	3800	1	200	2500	1	400	Y	100	50	700	100	350	300	0.4	60
BQ7791508	4200	4.5	100	3000	4.5	200	Y	100	70	1420	140	700	300	0.4	60
BQ7791513	4300	4.5	100	1800	9	200	N	Disabled							
BQ7791514	3650	1	100	2500	1	200	Y	100	50	700	100	350	200	0.4	50

Table 6-2. Device Comparison Table (continued)

Part Number	Current Fault Recovery		Temperature (°C) ⁽¹⁾				Cell Balancing		
	Delay (ms)	Method	OTD	OTC	UTD	UTC	V _{START} (V)	V _{HYST} (V _{OV} - V _{FC}) (mV)	V _{STEP} (V _{CBTH} - V _{CBTL}) (mV)
BQ7791500	N/A	Load removal only (OCD1, OCD2, SCD)/load detection only (OCC)	65	45	-10	0	3.8	100	100
BQ7791501	N/A	Load removal only (OCD1, OCD2, SCD)/load detection only (OCC)	70	50	-20	0	3.8	100	100
BQ7791502	N/A	Load removal only (OCD1, OCD2, SCD)/load detection only (OCC)	65	45	-10	0	3.8	100	100
BQ7791504	Disabled	N/A	Disabled				3.5	50	50
BQ7791506	N/A	Load removal only (OCD1, OCD2, SCD)/load detection only (OCC)	65	50	-10	0	3.5	100	50
BQ7791508	500	Load removal only (OCD1, OCD2, SCD)/load detection only (OCC)	65	50	-20	-5	3.8	100	50
BQ7791513	Disabled	N/A	Disabled				3.8	150	50
BQ7791514	N/A	Load removal only (OCD1, OCD2, SCD)/load detection only (OCC)	65	50	-10	0	3.5	100	50

- (1) These thresholds are targets, based on temperature, but they are dependent on external components that could vary based on customer selection. The circuit is based on a 103AT NTC thermistor connected to TS and VSS, and a 10-kΩ resistor connected to VTB and TS. Actual thresholds are determined in mV; refers to the overtemperature and undertemperature mV threshold in the *Electrical Characteristics* table.

7 Pin Configuration and Functions

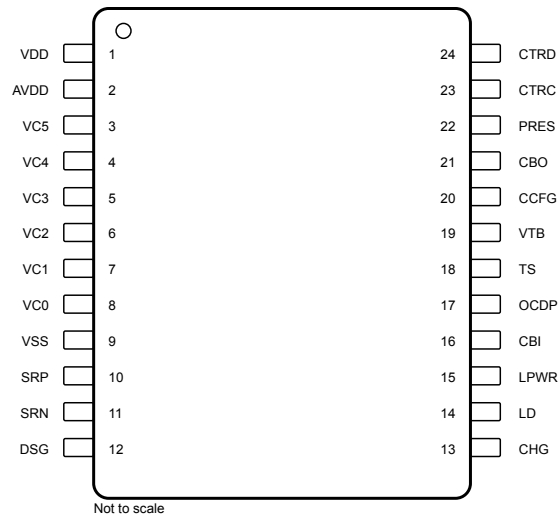

Figure 7-1. PW Package 24-Pin TSSOP Top View

Table 7-1. Pin Functions

NUMBER	NAME	I/O	DESCRIPTION
1	VDD	P ⁽¹⁾	Supply voltage
2	AVDD	O	Analog supply (only connect to a capacitor)
3	VC5	I	Cell voltage sense inputs
4	VC4	I	
5	VC3	I	
6	VC2	I	
7	VC1	I	
8	VC0	I	
9	VSS	P	Analog ground
10	SRP	I	Current sense input connecting to the battery side of the sense resistor
11	SRN	I	Current sense input connecting to the pack side of the sense resistor
12	DSG	O	DSG FET driver output
13	CHG	O	CHG FET driver output
14	LD	I	PACK– load removal detection
15	LPWR	O	HIBERNATE mode communication pin. Connect to the PRES pin of the lower device in a stack configuration. For a single device, leave the LPWR pin floating.
16	CBI	I	Cell balancing input. Leave the CBI pin floating to disable cell balancing, and do not drive with an external supply. Drive the pin low to enable cell balancing. In a stacked configuration, connect the CBI pin of an upper device to the CBO pin of the immediate lower device.
17	OCDP	I	Connecting a resistor from this pin to VSS programs the OCD1/2 fault detection delay. Connect to a 10-M Ω resistor to VSS for the upper devices in a stack.
18	TS	I	Thermistor measurement input. Connect a 10-k Ω resistor to the VSS pin if the function is not used.
19	VTB	O	Thermistor bias output
20	CCFG	I	Cell in-series configuration input
21	CBO	O	Cell balancing output. Connect through a 10-k resistor to the CBI pin of the upper device in a stacked configuration. For a single device, leave the CBO pin floating.
22	PRES	I	HIBERNATE mode input. Drive high for NORMAL mode operation. Leave the PRES pin floating for HIBERNATE mode. Connect to the LPWR pin of the upper device in a stack configuration.

Table 7-1. Pin Functions (continued)

NUMBER	NAME	I/O	DESCRIPTION
23	CTRC	I	CHG and DSG override inputs
24	CTRD	I	

(1) I = Input, O = Output, P = Power

8 Specifications

8.1 Absolute Maximum Ratings

Over operating free-air temperature range (unless otherwise noted). All values are referenced to VSS unless otherwise noted.⁽¹⁾

		MIN	MAX	UNIT	
V _I	Input voltage	VDD, VC5, VC4, VC3, VC2, VC1, CTRD, CTRC	-0.3	36	V
		LD	-30	20	V
		PRES	-0.3	36	V
		VC0, SRN, SRP, TS, AVDD, CCFG, CBI	-0.3	3.6	V
V _O	Output voltage	DSG	-0.3	20	V
		CHG	-30	20	V
		CBO	-0.3	36	V
		LPWR	-30	3.6	V
V _O	Output voltage	VTB, OCDP	-0.3	3.6	V
I _I	Input current	LD, CHG		500	μA
		DSG		1	mA
I _O	Output current	CHG, DSG		1	mA
I _O	Output current	Cell Balancing current (VC5, VC4, VC3, VC2, VC1, VC0)		50	mA
Lead temperature (soldering, 10 s), T _{SOLDER}				300	°C
Storage temperature, T _{stg}			-65	150	°C

(1) Operation outside the Absolute Maximum Ratings may cause permanent device damage. Absolute Maximum Ratings do not imply functional operation of the device at these or any other conditions beyond those listed under Recommended Operating Conditions. If outside the Recommended Operating Conditions but within the Absolute Maximum Ratings, the device may not be fully functional, and this may affect device reliability, functionality, performance, and shorten the device lifetime.

8.2 ESD Ratings

		VALUE	UNIT
V _(ESD)	Electrostatic discharge	Human-body model (HBM), per ANSI/ESDA/JEDEC JS-001 ⁽¹⁾	±1000
		Charged-device model (CDM), per JEDEC specification JESD22-C101 ⁽²⁾	±250

(1) JEDEC document JEP155 states that 500-V HBM allows safe manufacturing with a standard ESD control process.

(2) JEDEC document JEP157 states that 250-V CDM allows safe manufacturing with a standard ESD control process.

8.3 Recommended Operating Conditions

Over operating free-air temperature range (unless otherwise noted)

		MIN	NOM	MAX	UNIT
V _{BAT}	Supply voltage	VDD	3	25	V

8.3 Recommended Operating Conditions (continued)

Over operating free-air temperature range (unless otherwise noted)

		MIN	NOM	MAX	UNIT
V _I	Input voltage range	VC5-VC4, VC4-VC3, VC3-VC2, VC2-VC1, VC1-VC0	0	5	V
		CTRD, CTRC	0	(VDD + 5)	
		CCFG, CBI	0	AVDD	
		PRES	0	16	
		SRN, SRP	-0.2	0.8	
		LD	0	16	
		TS	0	VTB	
V _O	Output voltage range	CHG, DSG	0	16	V
		VTB, AVDD, LPWR	0	3	
		CBO	0	VDD	
T _{OPR}	Operating free-range temperature	-40		85	°C
R _{INE}	Cell monitor filter resistance (External Cell balancing)	± 5% tolerance	1		kΩ
C _{INE}	Cell monitor filter capacitance (External Cell balancing)	± 10% tolerance	0.1		μF
R _{INI}	Cell monitor filter resistance (Internal Cell balancing. 50-mA balancing current at 4.2-V cell voltage)	± 5% tolerance	33		Ω
C _{INI}	Cell monitor filter capacitance (Internal Cell balancing)	± 10% tolerance	1		μF
R _{VDD}	Supply voltage filter resistance	± 5% tolerance	1		kΩ
C _{VDD}	Supply voltage filter capacitance	± 20% tolerance	1		μF
R _{TS}	Thermistor	103AT, ± 3% tolerance	10		kΩ
R _{TS_PU}	Thermistor pullup resistor to VTB	± 1% tolerance	10		kΩ
R _{GS_CHG}	CHG FET gate-source resistor	± 5% tolerance	1		MΩ
R _{GS_DSG}	DSG FET gate-source resistor	± 5% tolerance	1		MΩ
R _{DSG}	DSG gate resistor, System designers should adjust this parameter to meet the desirable FET rise/fall time.	± 5% tolerance	4.5		kΩ
R _{CHG}	CHG gate resistor	± 5% tolerance. System designers should adjust this parameter to meet the desirable FET rise/fall time.	1		kΩ
		± 5% tolerance. If additional components are used to protect the CHG FET and/or to enable load removal detection for UV recovery.	1		MΩ
R _{CTRC}	CTRC current limit resistor	± 5% tolerance	10		MΩ
R _{CTRD}	CTRD current limit resistor	± 5% tolerance	10		MΩ
R _{LD}	LD resistor for load removal detection	± 5% tolerance	470		kΩ
R _{CB}	Resistor between CBO of lower device and CBI of upper device	± 5% tolerance	10		kΩ
R _{HIB}	Resistor between LPWR of upper device and PRES of upper device	± 5% tolerance	10		kΩ
R _{SNS}	Current sense resistor for current protection. System designers should change this parameter according to the application current protection requirement.	± 1% tolerance	1		mΩ

8.4 Thermal Information

Over operating free-air temperature range (unless otherwise noted)

THERMAL METRIC		BQ77915 PW (TSSOP) 24 PINS	UNIT ⁽¹⁾
R _{θJA}	Junction-to-ambient thermal resistance	88.9	°C/W
R _{θJC(top)}	Junction-to-case thermal resistance	26.5	°C/W
R _{θJB}	Junction-to-board thermal resistance	43.5	°C/W
Ψ _{JT}	Junction-to-top characterization parameter	1.1	°C/W
Ψ _{JB}	Junction-to-board characterization parameter	43	°C/W

(1) For more information about traditional and new thermal metrics, see the [Semiconductor and IC Package Thermal Metrics Application Report, SPRA953](#) SPRA953.

8.5 Electrical Characteristics

Typical values stated at T_A = 25°C and VDD = 20 V. MIN and MAX values stated with T_A = –40°C to 85°C and VDD = 3 to 25 V unless otherwise noted.

PARAMETER	TEST CONDITIONS	MIN	TYP	MAX	UNIT			
SUPPLY VOLTAGE								
V _{POR}	POR threshold	VDD rising, 0 to 6 V			4	V		
V _{SHUT}	Shutdown threshold	VDD falling, 6 to 0 V			2	3.25	V	
V _{AVDD}	AVDD voltage	C _{VDD} = 1 μF			2.1	3.6	V	
SUPPLY AND LEAKAGE CURRENT								
I _{CC}	NORMAL mode current	Cell1 through Cell5 = 4 V, VDD = 20 V, No cell balancing		8	15	μA		
		Cell balancing cells 3, 4 or 5		48	80	μA		
I _{HIB}	HIBERNATE mode current	Cell1 through Cell5 = 4 V, VDD = 20 V, HIBERNATE mode			2	3	μA	
I _{CFault}	Fault condition current	State comparator on			10	15	μA	
I _{OFF}	SHUTDOWN mode current	VDD < V _{SHUT} , CT _{RC} /CT _{RD} floating			0.5		μA	
I _{LKG_OW_DIS}	Input leakage current at VCx pins	All cell voltages = 4 V, open-wire disable configuration			–100	0	100	nA
I _{LKG_100nA}	Open-wire sink current at VCx pins	All cell voltages = 4 V, 100-nA configuration			30	110	175	nA
I _{LKG_200nA}	Open-wire sink current at VCx pins	All cell voltages = 4 V, 200-nA configuration			95	210	315	nA
I _{LKG_400nA}	Open-wire sink current at VCx pins	All cell voltages = 4 V, 400-nA configuration			220	425	640	nA
PROTECTION ACCURACIES								
V _{OV}	Overvoltage programmable threshold range				3000	4575	mV	
V _{UV}	Undervoltage programmable threshold range				1200	3000	mV	
V _{VA}	OV, UV, detection accuracy	T _A = 25°C, OV detection accuracy			–10	10	mV	
		T _A = 25°C, UV detection accuracy			–18	18	mV	
		T _A = 0 to 60°C			–28	26	mV	
		T _A = –40 to +85°C			–40	40	mV	
V _{HYS_OV}	OV hysteresis programmable threshold range				0	400	mV	
V _{HYS_UV}	UV hysteresis programmable threshold range				0	800	mV	

8.5 Electrical Characteristics (continued)

Typical values stated at $T_A = 25^\circ\text{C}$ and $V_{DD} = 20\text{ V}$. MIN and MAX values stated with $T_A = -40^\circ\text{C}$ to 85°C and $V_{DD} = 3$ to 25 V unless otherwise noted.

PARAMETER		TEST CONDITIONS	MIN	TYP	MAX	UNIT
V_{OTD}	Overtemperature in discharge programmable threshold	Threshold for 65°C based on a 10k pullup and 103AT thermistor	19.69%	20.56%	21.86%	VTB
		Threshold for 70°C based on a 10k pullup and 103AT thermistor	17.28%	18.22%	19.51%	VTB
V_{OTD_REC}	Overtemperature in discharge recovery	Recovery threshold at 55°C for when V_{OTD} is at 65°C based on a 10k pullup and 103AT thermistor	25.18%	26.12%	27.44%	VTB
		Recovery threshold at 60°C for when V_{OTD} is at 70°C based on a 10k pullup and 103AT thermistor	22.05%	23.2%	24.24%	VTB
V_{OTC}	Overtemperature in charge programmable threshold	Threshold for 45°C based on a 10k pullup and 103AT thermistor	32.14%	32.94%	34.54%	VTB
		Threshold for 50°C based on a 10k pullup and 103AT thermistor	29.15%	29.38%	31.45%	VTB
V_{OTC_REC}	Overtemperature in charge recovery	Recovery threshold at 35°C for when V_{OTD} is at 45°C based on a 10k pullup and 103AT thermistor	38.63%	40.97%	40.99%	VTB
		Recovery threshold at 40°C for when V_{OTD} is at 50°C based on a 10k pullup and 103AT thermistor	36.18%	36.82%	38.47%	VTB
V_{UTD}	Undertemperature in discharge programmable threshold	Threshold for -20°C based on a 10k pullup and 103AT thermistor	86.41%	87.14%	89.72%	VTB
		Threshold for -10°C based on a 10k pullup and 103AT thermistor	80.04%	80.94%	83.10%	VTB
V_{UTD_REC}	Undertemperature in discharge recovery	Recovery threshold at -10°C for when V_{UTD} is at -20°C based on a 10k pullup and 103AT thermistor	80.04%	80.94%	83.10%	VTB
		Recovery threshold at 0°C for when V_{UTD} is at -10°C based on a 10k pullup and 103AT thermistor	71.70%	73.18%	74.86%	VTB
V_{UTC}	Undertemperature in charge programmable threshold	Threshold for -5°C based on a 10k pullup and 103AT thermistor	75.06%	77.22%	78.32%	VTB
		Threshold for 0°C based on a 10k pullup and 103AT thermistor	71.70%	73.18%	74.86%	VTB
V_{UTC_REC}	Undertemperature in Charge Recovery	Recovery threshold at 5°C for when V_{UTC} is at -5°C based on a 10k pullup and 103AT thermistor	68.80%	69.73%	71.71%	VTB
		Recovery threshold at 10°C for when V_{UTC} is at 0°C based on a 10k pullup and 103AT thermistor	64.67%	65.52%	67.46%	VTB
V_{OCC}	Overcurrent charge programmable threshold range, ($V_{SRP}-V_{SRN}$)		5		80	mV
V_{OCD1}	Overcurrent discharge 1 programmable threshold range		-85		-10	mV
V_{OCD2}	Overcurrent discharge 2 programmable threshold range		-170		-20	mV
V_{SCD}	Short circuit discharge programmable threshold range		-340		-40	mV
V_{CCAL}	OCD1 detection accuracy at lower thresholds	$VOCD1 \leq 20\text{ mV}$	-30 %		30 %	
V_{CCAH}	OCC, OCD1, OCD2, SCD detection accuracy	$VOCD1 > 20\text{ mV}$; all OCC, OCD2 and SCD threshold ranges	-20 %		20 %	

8.5 Electrical Characteristics (continued)

Typical values stated at $T_A = 25^\circ\text{C}$ and $V_{DD} = 20\text{ V}$. MIN and MAX values stated with $T_A = -40^\circ\text{C}$ to 85°C and $V_{DD} = 3$ to 25 V unless otherwise noted.

PARAMETER		TEST CONDITIONS	MIN	TYP	MAX	UNIT
V_{OW}	Open-wire fault voltage threshold at VC_x per cell with respect to VC_{x-1}	Voltage falling on VC_x , 3.6 V to 0 V	450	500	550	mV
V_{OW_HYS}	Hysteresis for open wire fault	Voltage rising on VC_x , 0 V to 3.6 V		100		mV
PROTECTION DELAYS						
t_{OVn_DELAY}	Overvoltage detection delay time	0.5-s delay option	0.4	0.5	0.8	s
		1-s delay option	0.8	1	1.4	
		2-s delay option	1.8	2	2.7	
		4.5-s delay option	4	4.5	5.2	
t_{UVn_DELAY}	Undervoltage detection delay time	1-s delay option	0.8	1	1.5	s
		2-s delay option	1.8	2	2.7	
		4.5-s delay option	4	4.5	5.5	
		9-s delay option	8	9	10.2	
t_{OWn_DELAY}	Open-wire detection delay time		3.6	4.5	5.3	s
t_{OTC_DELAY}	Overtemperature charge detection delay time		3.6	4.5	5.3	s
t_{UTC_DELAY}	Undertemperature charge detection delay time		3.6	4.5	5.3	s
t_{OTD_DELAY}	Overtemperature discharge detection delay time		3.6	4.5	5.3	s
t_{UTD_DELAY}	Undertemperature discharge detection delay time		3.6	4.5	5.3	s
t_{OCD1_DELAY}	Overcurrent discharge 1 detection delay time	10-ms delay option	8	10	15	ms
		20-ms delay option	17	20	26	
		45-ms delay option	36	45	52	
		90-ms delay option	78	90	105	
		180-ms delay option	155	180	205	
		350-ms delay option	320	350	405	
		700-ms delay option	640	700	825	
		1420-ms delay option	1290	1420	1620	
t_{OCD2_DELAY}	Overcurrent discharge 2 detection delay time	5-ms delay option	4	5	8	ms
		10-ms delay option	8	10	15	
		20-ms delay option	17	20	26	
		45-ms delay option	36	45	52	
		90-ms delay option	78	90	105	
		180-ms delay option	155	180	205	
		350-ms delay option	320	350	405	
		700-ms delay option	640	700	825	
t_{SCD_DELAY}	Short-circuit detection delay time	960- μs delay option	528	960	1450	μs
t_{SCD_DELAY}	Short-circuit detection delay time	400- μs delay option	220	400	610	μs
t_{OCC_DELAY}	Overcurrent charge detection delay time		8	10	12	ms
t_{CD_REC}	Overcurrent discharge 1, Overcurrent discharge 2, Overcurrent charge and short-circuit recovery delay time	250-ms option	225	250	275	ms
		500-ms option	450	500	550	
CHARGE AND DISCHARGE FET DRIVERS						

8.5 Electrical Characteristics (continued)

Typical values stated at $T_A = 25^\circ\text{C}$ and $V_{DD} = 20\text{ V}$. MIN and MAX values stated with $T_A = -40^\circ\text{C}$ to 85°C and $V_{DD} = 3$ to 25 V unless otherwise noted.

PARAMETER		TEST CONDITIONS	MIN	TYP	MAX	UNIT
V_{FETON}	CHG/DSG on	$V_{DD} \geq 12\text{ V}$, $CL = 10\text{ nF}$	11	12	14	V
		$V_{DD} < 12\text{ V}$, $CL = 10\text{ nF}$	$V_{DD} - 1.5$		V_{DD}	V
V_{FETOFF}	CHG/DSG off	1-mA resistive load, CHG clamped to ground when CHG/DSG is off.			0.5	V
t_{CHGON}	CHG on rise time	$CL = 10\text{ nF}$, 10% to 90%		50	150	μs
t_{DSGON}	DSG on rise time	$CL = 10\text{ nF}$, 10% to 90%		2	75	μs
t_{CHGOFF}	CHG off fall time	$CL = 10\text{ nF}$, 90% to 10%		15	30	μs
t_{DSGOFF}	DSG off fall time	$CL = 10\text{ nF}$, 90% to 10%		5	15	μs
R_{CHGOFF}	CHG off resistance	CHG off and pin held at 2V	0.3	0.5	0.75	$\text{k}\Omega$
R_{DSGOFF}	DSG off resistance	DSG off and pin held at 100 mV		10	16	Ω
CELL BALANCING						
V_{HYST}	Hysteresis between overvoltage and full charge voltage range (VOV – VFC, 4 steps of 50 mV)	$T_A = 25^\circ\text{C}$	50		200	mV
V_{STEP}	Difference between the cell balancing threshold voltages (VCBTH – VCBTL, 4 steps of 50 mV)	$T_A = 25^\circ\text{C}$	50		200	mV
V_{CBIL}	CBI low threshold				0.5	V
t_{CBI_DEG}	CBI deglitch period			100		ms
R_{BAL}	Cell balancing internal FET resistance	Cell1 through Cell5 = 4 V, $V_{DD} = 20\text{ V}$	8	12	20	Ω
D_{BAL}	Cell balancing duty cycle	Only one cell balanced in the stack		90 %		
t_{BAL}	Odd and even cell group balancing duration			521		ms
HIBERNATE MODE						
V_{PRESH}	PRES High Threshold		1.25	1.5	1.75	V
$t_{PRES_DEG_ENT}$	PRES deglitch time (hibernate entry)			4.5		s
$t_{PRES_DEG_EXT}$	PRES deglitch time (hibernate exit)			10		ms
CTRC AND CTRD CONTROL						
V_{CTR1}	Enable FET driver (VSS)	With respect to VSS. Enabled < MAX			0.6	V
V_{CTR2}	Enable FET driver (Stacked)	Enabled > MIN	$V_{DD} + 2.2$			V
V_{CTRDIS}	Disable FET driver	Disabled between MIN and MAX	2.04	$V_{DD} + 0.7$		V
$V_{CTRMAXV}$	CTRC and CTRD clamp voltage	$I_{CTR} = 600\text{ nA}$	$V_{DD} + 2.8$	$V_{DD} + 4$	$V_{DD} + 5$	V
t_{CTRDEG_ON}	CTRC and CTRD deglitch for ON signal			8		ms
t_{CTRDEG_OFF}	CTRC and CTRD deglitch for OFF signal			8		ms
CURRENT STATE COMPARATOR						
V_{STATE_D}	Discharge qualification threshold1	Measured at SRP-SRN	–1.875			mV
$V_{STATE_D_HYS}$	Discharge qualification threshold1 hysteresis	Measured at SRP-SRN	–1.25			mV
V_{STATE_C}	Charge qualification threshold1	Measured at SRP-SRN	1.875			mV
$V_{STATE_C_HYS}$	Charge qualification threshold1 hysteresis	Measured at SRP-SRN	1.25			mV
t_{STATE}	State detection qualification time				1.2	ms

8.5 Electrical Characteristics (continued)

Typical values stated at $T_A = 25^\circ\text{C}$ and $V_{DD} = 20\text{ V}$. MIN and MAX values stated with $T_A = -40^\circ\text{C}$ to 85°C and $V_{DD} = 3$ to 25 V unless otherwise noted.

PARAMETER		TEST CONDITIONS	MIN	TYP	MAX	UNIT
LOAD DETECTION AND LOAD REMOVAL DETECTION						
$V_{LDCLAMP}$	LD clamp voltage	$I_{LDCLAMP} = 300\ \mu\text{A}$	16	19	20	V
$I_{LDCLAMP}$	LD clamp current	$V_{LDCLAMP} = 18\text{ V}$			450	μA
V_{LDT}	LD threshold	OPEN pack terminals	1.25	1.3	1.35	V
R_{LD_INT}	LD input resistance when enabled	Measured to VSS		200		k Ω
t_{LD_DEG}	LD detection de-glitch		1	1.5	2.3	ms
CCFG PIN						
V_{CCFG_L}	CCFG threshold low (ratio of V_{AVDD})	3-cell configuration			10%	AVDD
V_{CCFG_H}	CCFG threshold high (ratio of V_{AVDD})	4-cell configuration	65%		100%	AVDD
V_{CCFG_HZ}	CFG threshold high-Z (ratio of V_{AVDD})	5-cell configuration, CCFG floating, internally biased	25%	33%	45%	AVDD
t_{CCFG_DEG}	CCFG deglitch			6		ms
CUSTOMER TEST MODE						
V_{CTM}	Customer test mode entry voltage at VDD	$V_{DD} > V_{C5} + V_{CTM}$, $T_A = 25^\circ\text{C}$	8.5		10	V
t_{CTM_ENTRY}	Delay time to enter and exit customer test mode	$V_{DD} > V_{C5} + V_{CTM}$, $T_A = 25^\circ\text{C}$	50			ms
t_{CTM_DELAY}	Delay time of faults while in customer test mode	$T_A = 25^\circ\text{C}$			200	ms
$t_{CTM_OC_REC}$	Fault recovery time of OCD1, OCD2, and SCD faults while in customer test mode	250-ms and 500-ms options, $T_A = 25^\circ\text{C}$			100	ms

8.6 Typical Characteristics

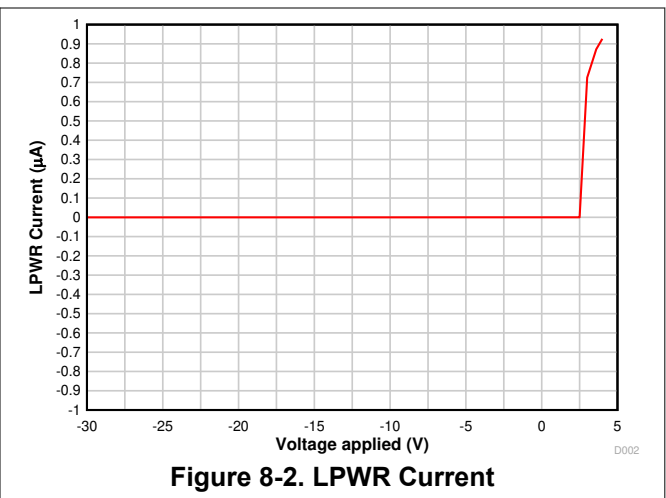
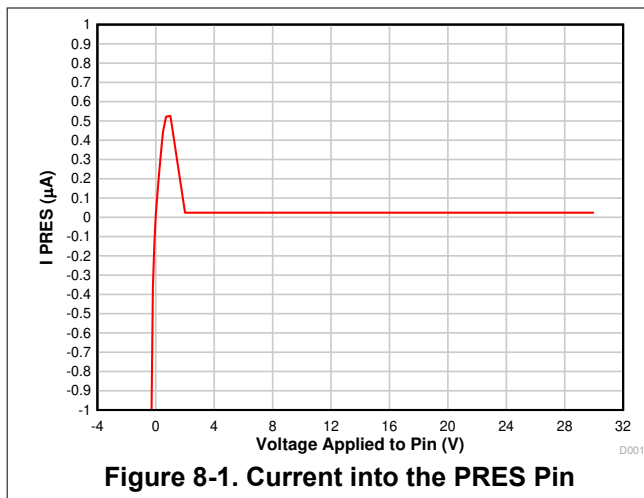

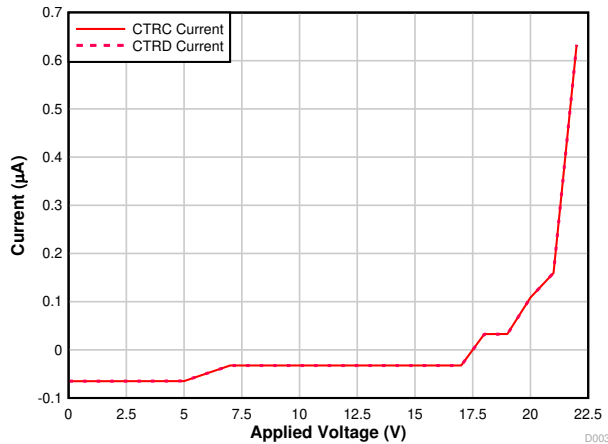

Figure 8-3. CTRC and CTRD Current

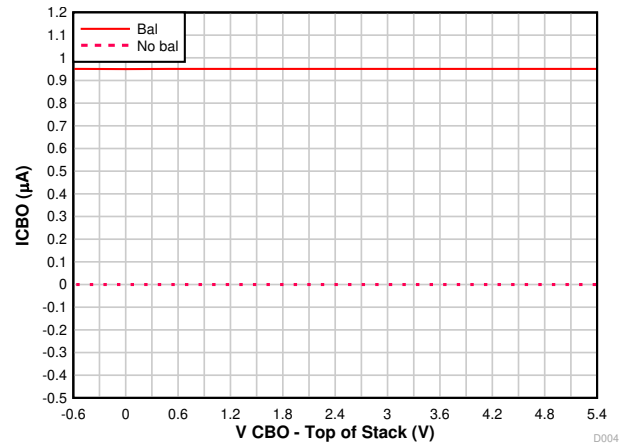

Figure 8-4. CBO Current Input at 18 V

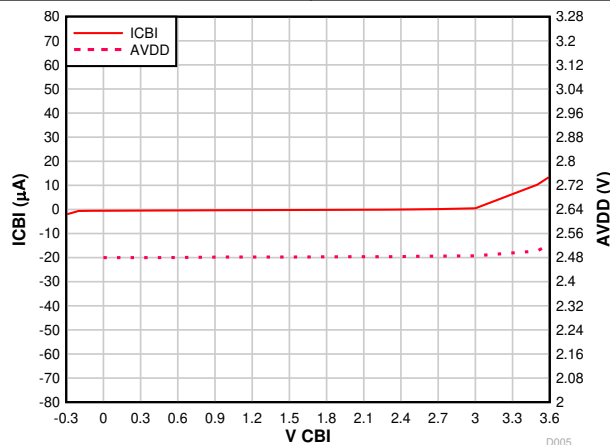

Figure 8-5. CBI Input Current vs. VCBI

9.1 Overview

The BQ77915 device is a full-feature stackable primary protector for Li-ion/Li-polymer batteries with a smart cell-balancing algorithm. The device implements a suite of protections that include the following:

- Cell voltage: overvoltage, undervoltage
- Current: overcurrent charge, overcurrent discharge 1 and 2, short circuit discharge
- Temperature: overtemperature and undertemperature in charge and discharge
- PCB: cell open-wire connection
- FET body diode protection

Protection thresholds and delays are factory-programmed and available in a variety of configurations.

The BQ77915 device supports 3-series to 5-series cell configurations. Up to four devices stack to support ≥ 6 -series cell configurations, providing protections up to a 20-series cell configuration. It is possible to support greater than 20-series cell configurations, but with careful consideration of delays.

The device has an ultra-low current HIBERNATE mode for shipping and storage. The device also features a smart cell-balancing algorithm to minimize cell-to-cell imbalance. The BQ77915 has built-in CHG and DSG drivers for low-side N-channel FET protection, which automatically open up the CHG and/or DSG FETs after protection delay time when a fault is detected. A set of CHG/DSG overrides enables disabling the CHG and/or DSG driver externally. Although the host system can use this function to disable the FET control, the main usage of these pins is to channel down the FET control signal from the upper device to the lower device in a cascading configuration in ≥ 6 -series battery packs.

9.1.1 Device Functionality Summary

Table 9-1. Device Functionality Summary

FAULT DESCRIPTOR		FAULT DETECTION THRESHOLD and DELAY OPTIONS		FAULT RECOVERY METHOD and SETTING OPTIONS	
OV	Overvoltage	3 V to 4.575 V (25-mV step)	0.5, 1, 2, 4.5 s	Hysteresis	0, 100, 200, 400 mV
UV	Undervoltage	1.2 V to 3 V (100-mV step for < 2.5 V, 50-mV step for ≥ 2.5 V)	1, 2, 4.5, 9 s	Load removal + hysteresis	0, 200, 400, 800 mV
OW	Open wire (cell to pcb disconnection)	0 (disabled), 100 nA, 200 nA, 400 nA	4.5 s	Restore bad VCx to PCB connection	VCx > V _{OW}
OTD ⁽¹⁾	Overtemperature during discharge	65°C or 70°C	4.5 s	Hysteresis or load removal + hysteresis	10°C
OTC ⁽¹⁾	Overtemperature during charge	45°C or 50°C	4.5 s	Hysteresis	10°C
UTD ⁽¹⁾	Undertemperature during discharge	-20°C or -10°C	4.5 s	Hysteresis	10°C
UTC ⁽¹⁾	Undertemperature during charge	-5°C or 0°C	4.5 s	Hysteresis	10°C
OCC	Overcurrent during charge	5 mV to 80 mV (5-mV step)	10 ms	Timer auto-release and load detection, timer auto-release only, load detection only	250 ms or 500 ms
OCD1	Overcurrent1 during discharge	-10 mV to -85 mV (5-mV step)	10, 20, 45, 90, 180, 350, 700, 1420 ms	Timer auto-release and load removal, timer auto-release only, load removal only	
OCD2	Overcurrent2 during discharge	-20 mV to -170 mV (10-mV step)	5, 10, 20, 45, 90, 180, 350, 700 ms		
SCD	Short circuit discharge	-40 mV to -340 mV (20-mV step)	400, 960 μs		
CTRC	CHG signal override control	Disable through external control or through CHG signal from the upper device in stack configuration	t _{CTRDEG_ON}	Enable through external control or through the CHG signal from the upper device in stack configuration	t _{CTRDEG_OFF}
CTRD	DSG signal override control	Disable through external control or through DSG signal from the upper device in stack configuration	t _{CTRDEG_ON}	Enable through external control or through the DSG signal from the upper device in stack configuration	t _{CTRDEG_OFF}

- (1) These thresholds are target-based on temperature, but they are dependent on external components that could vary based on customer selections. The circuit is based on a 103AT NTC thermistor connected to TS and VSS, and a 10-kΩ resistor connected to VTB and TS. Actual thresholds are determined in mV; refers to the over- and undertemperature mV threshold in the *Electrical Characteristics* table.

Table 9-2. Cell Balancing Threshold Summary

NAME	Description	Options
V _{START}	Start threshold for cell balancing	3.5 V, 3.8 V
V _{HYST}	Hysteresis between overvoltage and full charge voltage range (VOV – VFC)	50 mV, 100 mV, 150 mV, 200 mV
V _{STEP}	Difference between the cell balancing threshold voltages (VCBTH – VCBTL)	50 mV, 100 mV, 150 mV, 200 mV

9.2 Functional Block Diagram

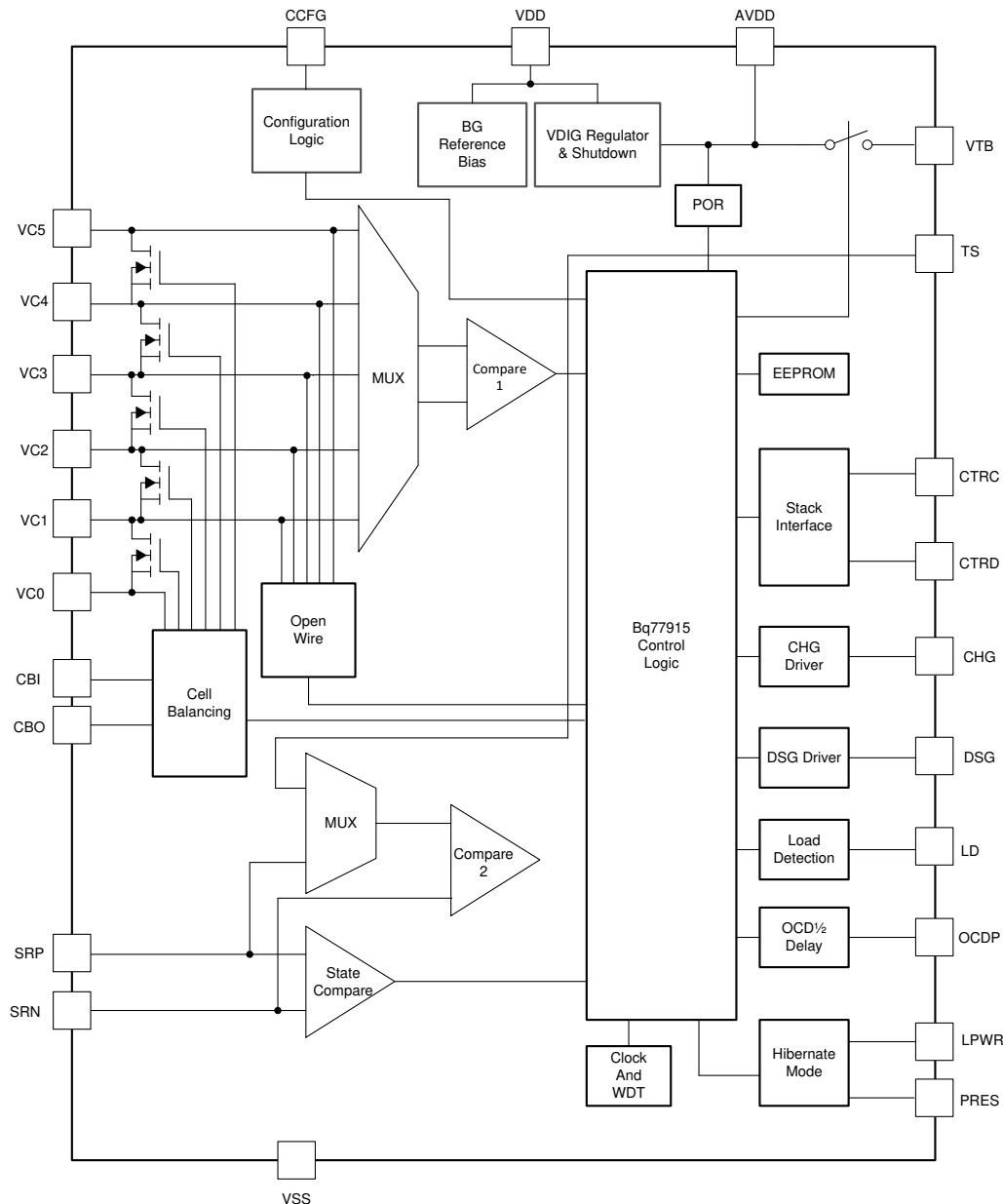

9.3 Feature Description

9.3.1 Protection Summary

Two comparators are time-multiplexed to detect all of the protection fault conditions, and to measure cell voltages for balancing. Each of the comparators runs on a time-multiplexed schedule and cycles through the assigned protection fault checks and voltage measurements. Comparator 1 checks for OV, UV, OW, OTC, OTD, UTC, and UTD protection faults and measure individual cell voltages for balancing. Comparator 2 checks for OCD1, OCD2, SCD, and OCC protection faults. For OV, UV, and OW protection faults and cell balancing, every cell is checked individually in a round-robin fashion, starting with cell 1 and ending with the highest selected cell. The number of the highest cell is configured using the CCFG pin.

Devices can be ordered with various timing and hysteresis settings. See [Table 9-1](#) for more details.

9.3.2 Fault Operation

9.3.2.1 Operation in OV

An OV fault detection occurs when at least one of the cell voltages is measured above the OV threshold, V_{OV} for a time of OV delay, t_{OVn_DELAY} . The CHG FET is turned off. The OV fault recovers when the voltage of the cell in fault is below the (OV threshold – OV hysteresis, V_{HYS_OV}) for a time of OV delay.

The device assumes an OV fault after reset, and clears automatically after an OV delay if all cell voltages are below the OV threshold minus hysteresis. In the event of an overvoltage fault condition on a particular cell, the balancing FET corresponding to that cell is turned on until the cell voltage drops to the full charge voltage or until the cell has recovered from overvoltage fault condition, whichever occurs earlier. See [Cell Balancing](#) for more details.

The state comparator is turned on when CHG is turned off. If a discharge current is detected, the device immediately switches the CHG back on. The response time of the state comparator is typically in 700 μ s and does not pose any disturbance in the discharge event.

9.3.2.2 Operation in UV

A UV fault detection is when at least one of the cell voltages is measured below the UV threshold, V_{UV} , for a duration of a UV delay, t_{UVn_DELAY} . The DSG FET is turned off. The UV fault recovers when:

- The voltage of the cell in fault goes above the (UV threshold + UV hysteresis, V_{HYS_UV}) for a time of a UV delay OR
- The voltage of the cell in fault goes above the (UV threshold + UV hysteresis, V_{HYS_UV}) for a time of a UV delay and the load is removed.

The state comparator turns on the DSG FET before the cell voltage recovers to protect the body diode.

To minimize device supply current when a UV fault has occurred or CTRD was driven to the DISABLED state, the BQ77915 device disables all discharge overcurrent detection blocks. Upon recovery from the fault or when CTRD is no longer externally driven, all discharge overcurrent detection blocks are reactivated.

9.3.2.3 Operation in OW

An OW fault detection is when at least one of the cell voltages is measured below the OW threshold, V_{OW} , for a duration of OW delay, t_{OWN_DELAY} . CHG and DSG are turned off. The OW fault recovers when the cell voltage in fault is above the OW threshold + OW hysteresis, V_{OW_HYS} , for a time of OW delay.

The t_{OWN_DELAY} time starts when the voltage at a given cell is detected below the V_{OW} threshold and is not from the time that the actual event of an open wire occurs. During an open-wire event, it is common that the device detects an undervoltage and/or overvoltage fault before detecting an open-wire fault. This occurs due to the differences in fault thresholds, fault delays, and the VCx pin filter capacitor values. For CHG and DSG to return to normal operation mode, the OW, OV, and UV faults' recovery conditions must be met.

9.3.2.4 Operation in OCD1

An OCD1 fault is when the discharge load is high enough that the voltage across the R_{SNS} resistor ($V_{SRP}-V_{SRN}$) is measured below the OCD1 voltage threshold, V_{OCD1} , for a duration of OCD1 delay, t_{OCD1_DELAY} . CHG and DSG are turned off.

The OCD1 fault recovers when:

- Load removal is detected only, $V_{LD} < V_{LDT}$, OR
- Overcurrent Recovery Timer, t_{CD_REC} , expiration only OR
- Overcurrent Recovery Timer expiration and load removal is detected.

9.3.2.5 Operation in OCD2

An OCD2 fault is when the discharge load is high enough that the voltage across the R_{SNS} resistor ($V_{SRP}-V_{SRN}$) is measured below the OCD2 voltage threshold, V_{OCD2} , for a duration of OCD2 delay, t_{OCD2_DELAY} . CHG and DSG are turned off.

The OCD2 fault recovers when:

- Load removal detected only, $V_{LD} < V_{LDT}$, OR
- Overcurrent Recovery Timer, t_{CD_REC} , expiration only OR
- Overcurrent Recovery Timer expiration and load removal is detected.

9.3.2.6 Programming the OCD1/2 Delay Using the OCDP Pin

OCD1 and OCD2 detection delays are programmed by the resistor connected from the OCDP pin to VSS. The device checks for the resistor value at power-up. For the bottom device in a stack, [Table 9-3](#) shows how the resistor values are chosen.

Table 9-3. OCD1/2 Delay Using OCDP Pin

Resistor Value	OCD1 Delay	OCD2 Delay
750 kΩ±1%	1420 ms	700 ms
604 kΩ±1%	700 ms	350 ms
487 kΩ±1%	350 ms	180 ms
383 kΩ±1%	180 ms	90 ms
294 kΩ±1%	90 ms	45 ms
196 kΩ±1%	45 ms	20 ms
100 kΩ±1%	EEPROM Delay Options (EC Table)	

The OCD2 delay is roughly half of the OCD1 delay when any of the first six resistors are connected from the OCDP pin to VSS. However, if a 100-kΩ resistor is connected, the OCD1 and OCD2 delays are independent of each other and can be chosen to have any value provided in the EC table.

For any device other than the bottom device in a stacked configuration, a 10-MΩ resistor must be connected from the OCDP pin of that device to the VSS pin of the device.

If the OCDP pin is left open, the OCD1 and OCD2 delays are determined by the EEPROM settings.

9.3.2.7 Operation in SCD

An SCD fault is when the discharge load is high enough that the voltage across the R_{SNS} resistor, ($V_{SRP}-V_{SRN}$), is measured below the SCD voltage threshold, V_{SCD} , for a duration of SCD delay, t_{SCD_DELAY} . CHG and DSG are turned off.

The SCD fault recovers when:

- Load removal detected only, $V_{LD} < V_{LDT}$, OR
- Overcurrent Recovery Timer, t_{CD_REC} , expiration only OR
- Overcurrent Recovery Timer expiration and load removal is detected.

9.3.2.8 Operation in OCC

An OCC fault is when the charging current is high enough that the voltage across the R_{SNS} resistor, ($V_{SRP}-V_{SRN}$), is measured above the OCC voltage threshold, V_{OCC} , for a duration of OCC delay, t_{OCC_DELAY} . CHG and DSG are turned off.

The OCC fault recovers when:

- Load detected only, $V_{LD} > V_{LDT}$, OR
- Overcurrent Recovery Timer, t_{CD_REC} , expiration only OR
- Overcurrent Recovery Timer expiration and load is detected.

9.3.2.9 Overcurrent Recovery Timer

The timer expiration method activates an internal recovery timer as soon as the initial fault condition exceeds the OCD1/OCD2/SCD/OCC time. When the recovery timer reaches its limit, both of the CHG and DSG drivers are turned back on. If the combination option of the timer expiration AND load removal/detection is used, then the load removal/detection condition is only evaluated upon expiration of the recovery timer, which can have an expiration period of t_{CD_REC} .

9.3.2.10 Load Detection and Load Removal Detection

The load detection and removal detection features are implemented with the LD pin. When no undervoltage fault and current fault conditions are present, the LD pin is held in an open-drain state. Once any UV, OCD1, OCD2, OCC, or SCD fault occurs and load removal or detection is selected as device of the recovery conditions, a high impedance pulldown path to VSS is enabled on the LD pin. With an external load still present, the LD pin will be externally pulled high: It is internally clamped to $V_{LDCLAMP}$ and is resistor-limited through R_{LD} externally to avoid conducting excessive current. If the LD pin voltage exceeds V_{LDT} for t_{LD_DEG} , it is interpreted as a *load present condition* and is one of the recovery mechanisms selectable for an OCC fault. When the load is eventually removed, the internal high-impedance path to VSS is sufficient to pull the LD pin below V_{LDT} for t_{LD_DEG} . This is interpreted as a *load removed condition* and is one of the recovery mechanisms selectable for UV, OCD1, OCD2, and SCD faults.

Table 9-4. Load State

LD PIN	LOAD STATE
$\geq V_{LDT}$ for t_{LD_DEG}	Load present
$< V_{LDT}$ for t_{LD_DEG}	Load removed

9.3.2.11 Operation in OTC

An OTC fault is when the temperature increases such that the voltage across an NTC thermistor goes below the OTC voltage threshold, V_{OTC} , for an OTC delay time, t_{OTC_DELAY} . CHG is turned off. The state comparator is turned on when CHG is turned off. If a discharge current is detected, the device immediately switches the CHG back on. The response time of the state comparator is typically in 700 μ s and does not pose a disturbance in the discharge event. The OTC fault recovers when the voltage across the thermistor goes above the OTC recovery threshold, V_{OTC_REC} , for an OTC delay time.

9.3.2.12 Operation in OTD

An OTD fault is when the temperature increases such that the voltage across an NTC thermistor goes below the OTD voltage threshold, V_{OTD} , for an OTD delay time, t_{OTD_DELAY} . CHG and DSG are turned off.

The OTD fault recovers when:

- The voltage across thermistor gets above OTD recovery threshold, V_{OTD_REC} , for a time of OTD delay OR
- The voltage across thermistor gets above OTD recovery threshold, V_{OTD_REC} , for a time of OTD delay and load is removed.

9.3.2.13 Operation in UTC

A UTC fault occurs when the temperature decreases such that the voltage across an NTC thermistor gets above the UTC voltage threshold, V_{UTC} , for a time of a UTC delay, t_{UTC_DELAY} . CHG is turned off. The state comparator is turned on when CHG is turned off. If a discharge current is detected, the device will immediately switch the CHG back on. The response time of the state comparator is typically in 700 μ s and not pose a disturbance in the discharge event. The UTC fault recovers when the voltage across thermistor gets below UTC recovery threshold, V_{UTC_REC} , for a time of UTC delay.

9.3.2.14 Operation in UTD

A UTD fault occurs when the temperature decreases such that the voltage across an NTC thermistor goes above the UTD voltage threshold, V_{UTD} , for a UTD delay time, t_{UTD_DELAY} . CHG and DSG are turned off. The UTD fault recovers when the voltage across thermistor gets below UTD recovery threshold, V_{UTD_REC} , for a time of UTD delay.

9.3.3 Protection Response and Recovery Summary

[Table 9-5](#) summarizes how each fault condition affects the state of the DSG and CHG output signals, as well as the recovery conditions required to resume charging and/or discharging. As a rule, the CHG and DSG output drivers are enabled only when no respective fault conditions are present. When multiple simultaneous faults (such as an OV and OTD) are present, all faults must be cleared before the FET can resume operation.

Table 9-5. Fault Condition, State, and Recovery Methods

FAULT	FAULT TRIGGER CONDITION	CHG	DSG	RECOVERY METHOD	TRIGGER DELAY	RECOVERY DELAY
CTRC disabled	CTRC disabled for deglitch delay time	OFF	—	CTRC must be enabled for deglitch delay time	t_{CTRDEG_ON}	t_{CTRDEG_OFF}
CTRD disabled	CTRD disabled for deglitch delay time	—	OFF	CTRD must be enabled for deglitch delay time		
OV	V(Cell) rises above V_{OV} for delay time	OFF	—	V(Cell) drops below $V_{OV} - V_{HYS_OV}$ for delay	t_{OVn_DELAY}	
UV	V(Cell) drops below V_{UV} for delay time	—	OFF	DSG FET turned on after Load is removed and V(Cell) rises above $V_{UV} + V_{HYS_UV}$ for delay.	t_{UVn_DELAY}	
OW	$VC_X - VC_{X-1} < V_{OW}$ for delay time	OFF	OFF	Bad VC_X recovers such that $VC_X - VC_{X-1} > V_{OW} + V_{OW_HYS}$ for delay	t_{OWn_DELAY}	
OCC	$(VSRP - VSRN) > VOCC$ for delay time	OFF	OFF	Recovery delay expires, OR LD detects $> V_{LDT}$, OR Recovery delay expires + LD detects $> V_{LDT}$	t_{OCC_DELAY}	t_{CD_REC}
OCD1, OCD2, SCD	$(VSRP - VSRN) < VOCD1$, $VOCD2$, or $VSCD$ for delay time	OFF	OFF	Recovery delay expires, OR LD detects $< V_{LDT}$, OR Recovery delay expires + LD detects $< V_{LDT}$	t_{OCD1_DELAY} , t_{OCD2_DELAY} , t_{SCD_DELAY}	t_{CD_REC}
OTC ⁽¹⁾	Temperature rises above T_{OTC} for delay time	OFF	—	Temp drops below $T_{OTC} - T_{OTC_REC}$ for delay	t_{OTC_DELAY}	
OTD ⁽¹⁾	Temperature rises above T_{OTD} for delay time	OFF	OFF	Temp drops below $T_{OTD} - T_{OTD_REC}$ for delay, OR Temp drops below $T_{OTD} - T_{OTD_REC}$ for delay and Load is removed	t_{OTD_DELAY}	
UTC ⁽¹⁾	Temperature drops below T_{UTC} for delay time	OFF	—	Temperature rises above $T_{UTC} + T_{UTC_REC}$ for delay	t_{UTC_DELAY}	
UTD ⁽¹⁾	Temp drops below T_{UTD} for delay time	OFF	OFF	Temp rises above $T_{UTD} + T_{UTD_REC}$ for delay	t_{UTD_DELAY}	

(1) T_{UTC} , T_{UTD} , T_{UTC_REC} , and T_{UTD_REC} correspond to the temperature produced by V_{UTC} , V_{UTD} , V_{UTC_REC} , and V_{UTD_REC} of the selected thermistor resistance.

To prevent FET damage, there are times when the CHG FET or DSG FET may be enabled even though a fault event has occurred. See the [State Comparator](#) section for details.

9.3.4 Cell Balancing

Cell balancing is performed by comparing the cell voltages with respect to cell balancing threshold voltages, evaluating the results of the comparison and controlling the cell balancing FET, which over a period of time will allow for closer cell voltages, thereby extending battery pack life. The conditions for performing cell balancing are: CBI is connected to VSS, no device in the stack is in a fault condition, and the pack is charging. The [State Comparator](#) section lists the conditions for the device's charging state.

CBI is the cell balancing input pin. It enables cell balancing function for the device.

- Leave the CBI pin floating to disable cell balancing. An internal circuit pulls up the CBI pin to AVDD in this case.
- Connect CBI to VSS to enable cell balancing.

In a single device, cell balancing of all the odd numbered cells can happen at the same time, and balancing of all the even numbered cells can also happen at the same time, but odd and even cells are not balanced at the same time. When devices are stacked on top of each other, verify in the PCB layout that the trace from VC5 pin to a cell and the trace from the VC0 pin of the next upper device to the immediately higher cell are kept separate.

All cell balancing FETs are turned off during voltage measurements. If odd numbered and even numbered cells need balancing at the same time, one single cycle time t_{BAL} is dedicated for odd numbered cells alone followed by the next t_{BAL} dedicated for even numbered cells alone. See an example of adjacent cell balancing in [Figure 9-1](#).

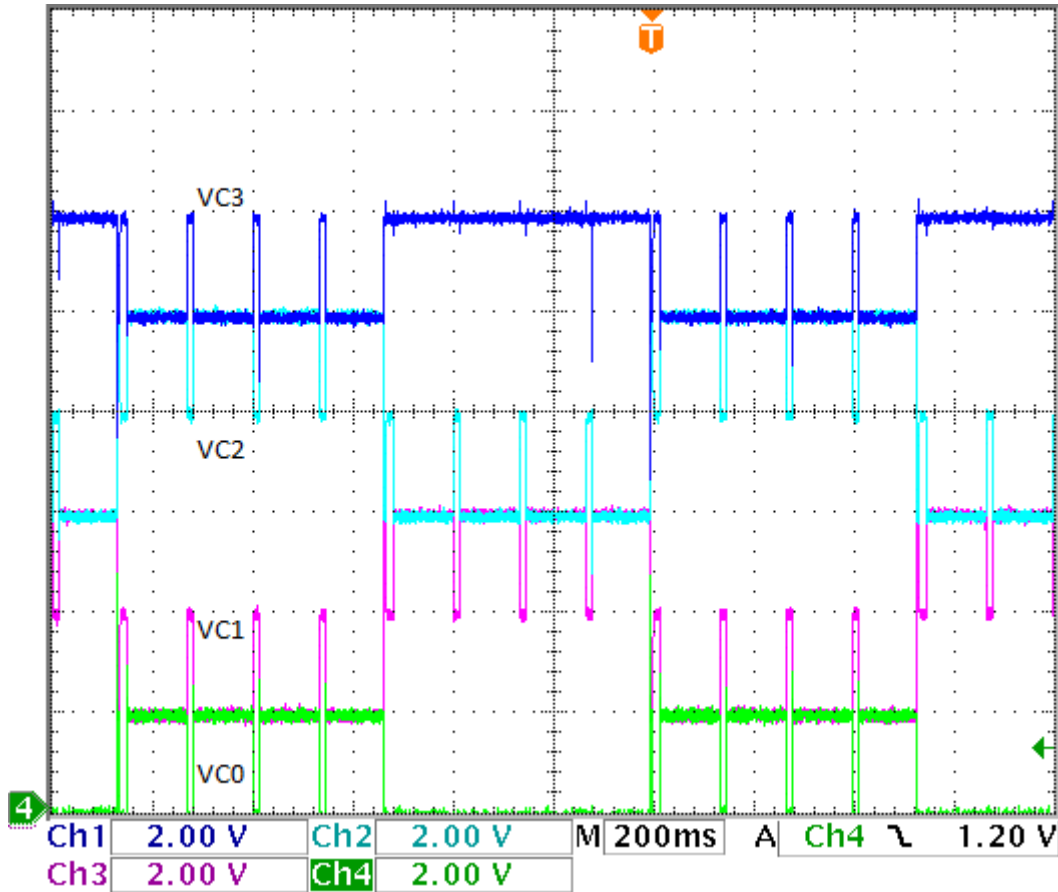

Figure 9-1. Balancing Cells 1, 2, and 3

In a stacked configuration, the CBO pin of the bottom device must be connected to the CBI pin of the next upper device through a 10-kΩ resistor and so forth.

When a cell is in OV, its corresponding balancing FET is turned on if CBI is connected to VSS and if there are no discharge faults anywhere in the stack. The balancing FET is ON until the cell voltage drops to V_{FC} or $V_{OV} - V_{HYS_OV}$, whichever occurs earlier.

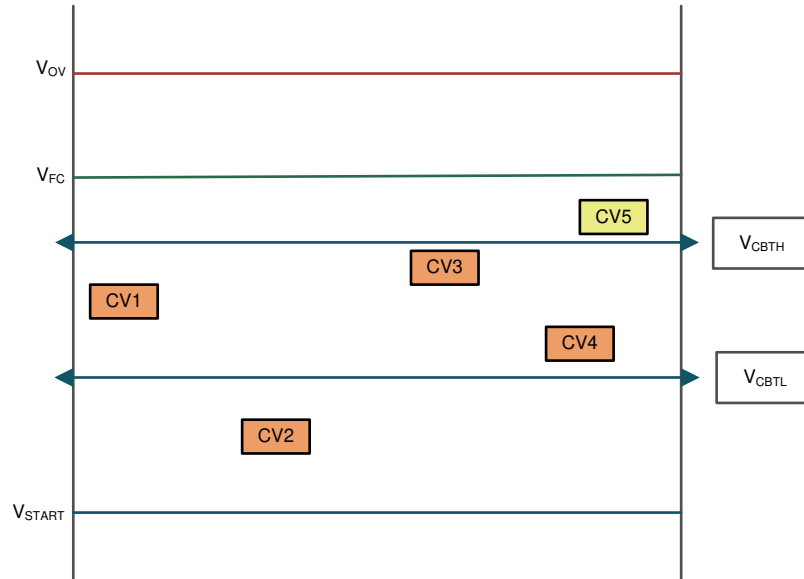

Figure 9-2. Cell-Balancing Algorithm

V_{CBTL} is the lower cell balancing threshold and V_{CBTH} is the upper cell balancing threshold. In [Figure 9-2](#), the balancing FET is turned on only for the cell CV5. The BQ77915 V_{START} is set at 3.8 V; therefore, cell balancing starts only when individual cell voltages exceed 3.8 V. The difference between V_{CBTH} and V_{CBTL} can be programmed in the EEPROM to be between 50 mV and 200 mV, in steps of 50 mV. The difference between the V_{OV} and V_{FC} can also be programmed in the EEPROM to be between 50 mV and 200 mV, in steps of 50 mV.

When using the integrated MOSFETs for cell balancing, the cell monitor filter resistance R_{INI} controls the amount of cell balancing current the device can supply to the cells. Internal cell balancing should be used for cell balancing currents up to 50 mA. External MOSFETs have to be used if higher cell balancing currents are required. In the case of external balancing, the balancing current is controlled by the resistor R_{CB} in series with the external MOSFET, as shown in [Figure 9-3](#). The pin filter resistance R_{INE} should be 1 k Ω and the capacitance C_{INE} should be 0.1 μ F. The gate bias voltage necessary to turn on the FET connected to Cell(n) is generated by the resistor R_{INE} connected to the $VC_{(n-1)}$ pin. The external MOSFET must be selected with a threshold voltage less than 1.7 V.

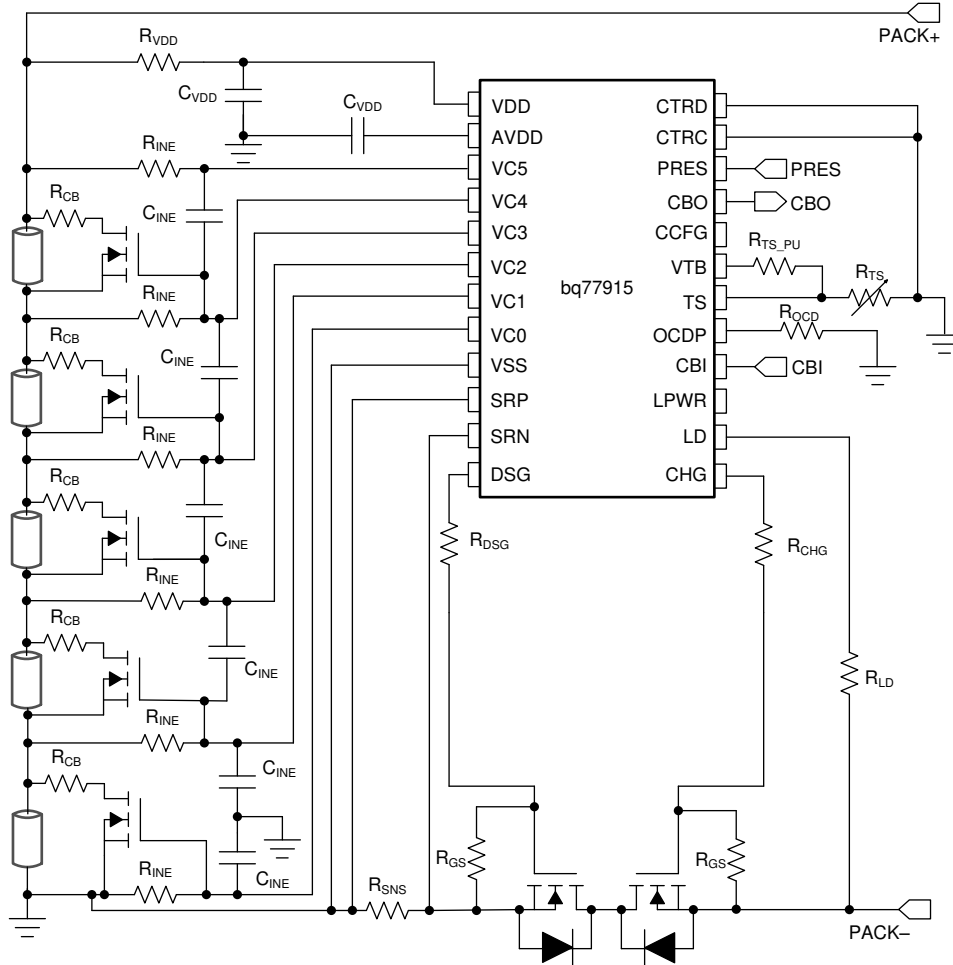

Figure 9-3. Cell Balancing with External MOSFETs

9.3.5 HIBERNATE Mode Operation

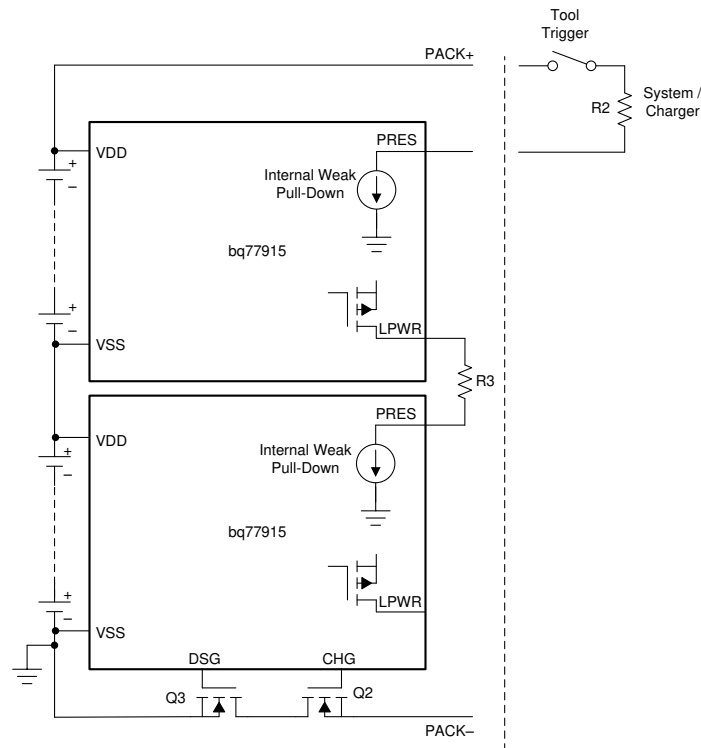

Figure 9-4. HIBERNATE Mode Simplified Schematic 1

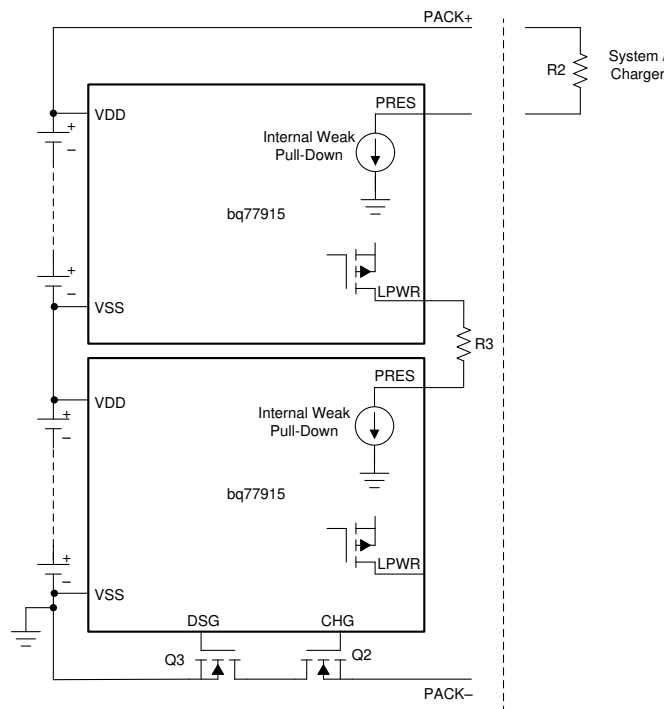

Figure 9-5. HIBERNATE Mode Simplified Schematic 2

The BQ77915 device has two dedicated pins (PRES and LPWR) for HIBERNATE mode operation. Most of the internal circuitry is turned off in HIBERNATE mode to save power. Charge and discharge FETs are turned off and all fault protections are disabled.

The PRES pin has an internal pulldown connected to the pin, which pulls PRES low. When the PRES pin is left floating (the system or charger is not connected to the pack), the load is not connected, and the device is not in any fault condition, the device enters HIBERNATE mode after $t_{PRES_DEG_ENT}$ time. Once in HIBERNATE mode, the system or the charger should drive this pin high ($>V_{PRESH}$) through the resistor R2 for NORMAL mode operation. When the battery pack (in HIBERNATE mode) is inserted to the tool/system or when a charger is connected to the pack, the system has to provide a pull-up to the PRES pin, which puts the device back to NORMAL mode. The device will exit HIBERNATE mode after a $t_{PRES_DEG_EXT}$ deglitch time.

In a stacked configuration, connect the LPWR pin of an upper device to the PRES pin of a lower device through the resistor R3.

9.3.6 Configuration CRC Check and Comparator Built-In-Self-Test

To improve reliability, the device has a built-in CRC check for all the factory-programmable configurations, such as the thresholds and delay time settings. When the device is set up in the factory, a corresponding CRC value is also programmed to the memory. During normal operation, the device compares the configuration setting against the programmed CRC periodically. A CRC error will reset the digital circuitry and increment the CRC fault counter. The digital reset forces the device to reload the configuration as an attempt to correct the configurations. A correct CRC check reduces the CRC fault counter. Three CRC fault counts will turn off both the CHG and DSG drivers. If FETs are opened due to a CRC error, only a POR can recover the FET state and reset the CRC fault.

In addition to the CRC check, the device also has built-in-self-test (BIST) on the comparators. The BIST runs in a scheduler, and each comparator is checked for a period of time. If a fault is detected for the entire check period, the particular comparator is considered at fault, and the CHG and DSG FETs are turned off. The BIST continues to run by the scheduler even if a BIST fault is detected. If the next BIST result is good, the FET driver resumes normal operation.

The CRC check and BIST check do not affect the normal operation of the device. However, there is not specific indication when a CRC or BIST error is detected besides turning off the CHG and DSG drivers. If there is no voltage, current, or temperature fault condition present, but CHG and DSG drivers remain off, it is possible either CRC or BIST error is detected. Users can POR the device to reset the device.

9.3.7 Fault Detection Method

9.3.7.1 Filtered Fault Detection

The device detects a fault once the applicable fault is triggered after accumulating sufficient trigger sample counts. The filtering scheme is based on a simple add/subtract. Starting with the triggered sample count cleared, the counts go up for a sample that is taken across the tested condition (for example, above the fault threshold when looking for a fault) and the counts go down for a sample that is taken before the tested condition (that is, below the fault threshold). [Figure 9-6](#) shows an example of a signal that triggers a fault when accumulating five counts above the fault threshold. Once a fault has been triggered, the trigger sample counts reset.

Note

With a filtered detection, when the input signal falls below the fault threshold, the sample count does not reset but only counts down, as shown in [Figure 9-6](#). Therefore, it is normal to observe a longer delay time if a signal is right at the detection threshold. The noise can push the delay count to be counting up and down, resulting in a longer time for the delay counter to reach its final accumulated trigger target.

Based on fault trigger after 5 counts

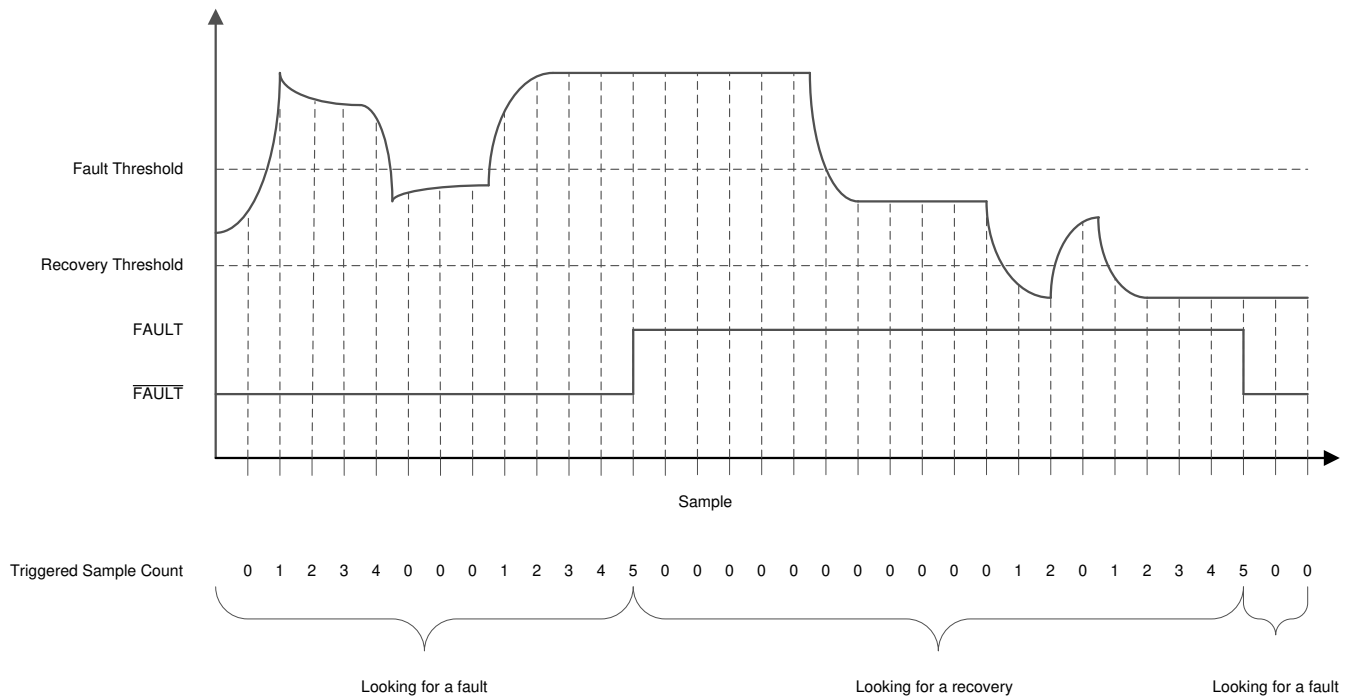

Figure 9-6. Filtered Fault Detection

9.3.8 State Comparator

A small, low-offset analog state comparator monitors the sense resistor voltage (SRP–SRN) to determine when the pack is in a DISCHARGE state less than a minimum threshold, $V_{\text{STATE_D}}$, or a CHARGE state greater than a maximum threshold, $V_{\text{STATE_C}}$. The state comparator turns on the CHG FET to prevent damage or overheating during discharge in fault states that call for having only the CHG FET off. This is vice versa for the DSG FET during charging in fault that call for having only the DSG FET off. Also, the state comparator is turned on in NORMAL mode (CHG and DSG FETs on) during cell balancing so that cell balancing is performed only when the pack is charging.

Table 9-6 summarizes when the state comparator is operational. The state comparator is on only during faults detected that call for only one FET to be turned off, and in NORMAL mode during cell balancing so that cell balancing is performed only when the pack is charging.

Table 9-6. State Comparator Operation Summary in Fault Conditions

MODE	CHG	DSG	STATE COMP
NORMAL mode, no cell balancing	ON	ON	OFF
NORMAL mode, cell balancing	ON	ON	$V_{\text{STATE_C}}$ detection
UV, CTRD	ON	OFF	$V_{\text{STATE_C}}$ detection
OV, UTC, OTC, CTRC	OFF	ON	$V_{\text{STATE_D}}$ detection
OCD1, OCD2, SCD, OCC, UTD, OTD, OW	OFF	OFF	OFF

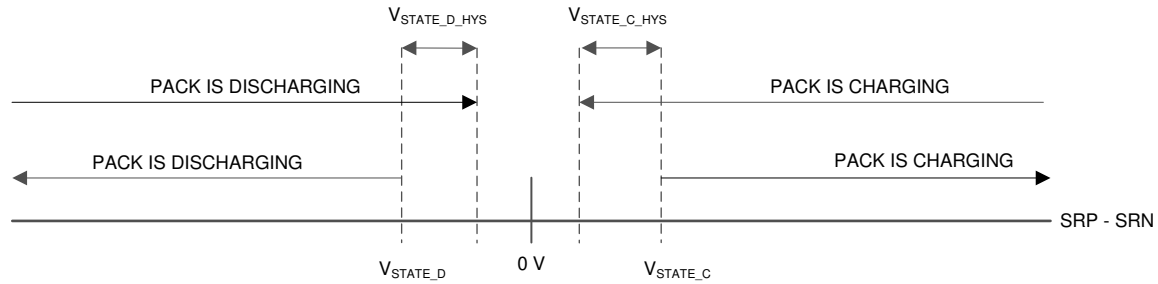

Figure 9-7. State Comparator Thresholds

Any time a CHG fault is present and a DSG fault is not present, the device enables the state comparator. If the pack is in a fault state where charging is prohibited but discharging is permitted (OV, OTC, UTC, and CTRC), a discharge is possible. When this happens, the CHG FET driver is turned on to avoid damage, as it otherwise carries the discharge current through its body diode. The state comparator (with the V_{STATE_D} threshold and $V_{STATE_D_HYS}$ hysteresis) remains on for the entire duration of a CHG fault with no DSG fault event.

If there is a DSG fault under CTRD conditions, the DSG FET is turned on if charge is detected. The state comparator (with V_{STATE_C} threshold and $V_{STATE_C_HYS}$ hysteresis) remains on for the entire duration of a DSG fault with no CHG fault event.

9.3.9 DSG FET Driver Operation

The DSG pin is driven high only when no related faults (UV, OW, OTD, UTD, OCD1, OCD2, SCD, OCC, and CTRD disabled) are present and the device is not in HIBERNATE mode of operation. It is a fast switching driver with a target on resistance of about $15\ \Omega$ – $20\ \Omega$ and an off resistance of $R_{DSG\ OFF}$. It is designed to enable customers to select the optimized R_{GS} value to archive the desirable FET rise and fall time per the application requirement and the choice of FET characteristics. When the DSG FET is turned off, the DSG pin drives low and all discharge overcurrent protections (OCD1, OCD2, SCD) are disabled to better conserve power. These resume operation when the DSG FET is turned on. The device provides FET body diode protection through the state comparator if one FET driver is on and the other FET driver is off.

The DSG driver may be turned on to prevent FET damage if the battery pack is charging while a discharge inhibit fault condition is present. This is done by the state comparator. The state comparator (with V_{STATE_C} threshold and $V_{STATE_C_HYS}$ hysteresis) remains on for the entire duration of a DSG fault with no CHG fault event.

- If $(SRP-SRN) \leq (V_{STATE_C} - V_{STATE_C_HYS})$ and no charge event is detected, the DSG FET output will remain OFF due to the presence of a DSG fault.
- If $(SRP-SRN) > V_{STATE_C}$ and a charge event is detected, the DSG FET output will turn ON for body diode protection.

See [State Comparator](#) for details.

The presence of any related faults, as shown in [Figure 9-8](#), results in the DSGFET_OFF signal.

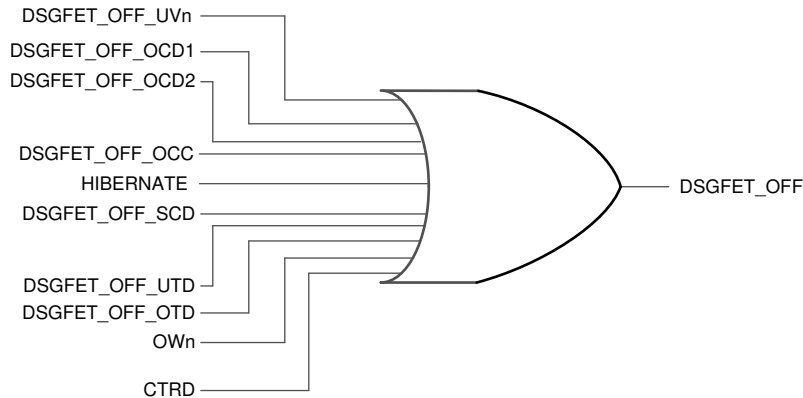

Figure 9-8. Faults that Can Qualify DSGFET_OFF

9.3.10 CHG FET Driver Operation

The CHG pin is driven high only when no related faults (OV, OW, OTC, UTC, OTD, UTD, OCD1, OCD2, SCD, OCC, and CTRC disabled) are present and the pack is not in HIBERNATE mode of operation. The CHG pin is used to drive the CHG FET, which is designed to be used on the single device configuration or used by the bottom device in a stack configuration.

Turning off the CHG pin has no influence on the overcurrent protection circuitry. The CHG pin is designed to turn on very quickly; the internal on resistance is about 2 k Ω . The CHG FET turn off relies on the external resistor connected in parallel to the gate-source nodes of the NCH power FET.

The CHG FET may be turned on to protect the FET's body diode if the pack is charging, even if a charging inhibit fault condition is present. This is done through the state comparator. The state comparator (with V_{STATE_D} threshold and $V_{STATE_D_HYS}$ hysteresis) remains on for the entire duration of a DSG fault with no CHG fault event.

- If $(SRP - SRN) > (V_{STATE_D} + V_{STATE_D_HYS})$ and no discharge event is detected, the CHG FET output will remain OFF due to the presence of a CHG fault.
- If $(SRP - SRN) \leq V_{STATE_D}$ and a discharge event is detected, the CHG FET output will turn ON for body diode protection.

The CHGFET_OFF signal is a result of the presence of any related faults as shown in [Figure 9-9](#).

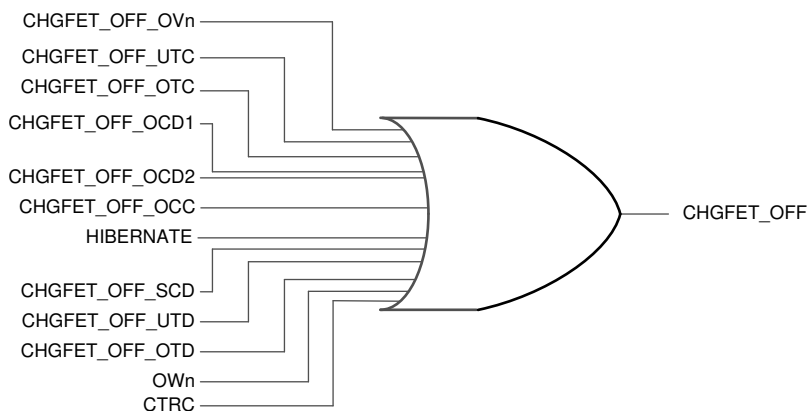

Figure 9-9. Faults that Can Qualify CHGFET OFF

9.3.11 External Override of CHG and DSG Drivers

The device allows direct disabling of the CHG and DSG drivers through the CTRC and CTRD pins, respectively. [Figure 9-10](#) shows the operation of the CTRC and CTRD pins. To support the simple-stack solution for higher-cell count packs, these pins are designed to operate above the device's VDD level. Connect a 10-M Ω resistor

between a lower device CTRC and CTRD input pins to an upper device's CHG and DSG output pins (see the schematics in [Section 9.3.13](#)).

CTRC only enables or disables the CHG pin, while CTRD only enables or disables the DSG pin. When the CTRx pin is in the DISABLED region, the respective FET pin is off, regardless of the state of the protection circuitry. When the CTRx pin is in either ENABLED region, the protection circuitry determines the state of the FET driver.

Note

In any event where CTRC is disabled, CTRD is enabled, no DSG FET related faults are present, and $(SRP-SRN) < V_{STATE_D}$, the CHG output pin is held high regardless. In any event where CTRD is disabled, CTRC is enabled, no charge FET related faults present, and $(SRP-SRN) > V_{STATE_C}$, the DSG output pin is held high regardless.

Both CTRx pins apply the fault-detection filtered method to improve the robustness of the signal detection. The counter counts up if an ENABLED signal is sampled; the counter counts down if a DISABLED signal is sampled. When the counter counts up from 0% to > 70% of its full range, which takes about 7-ms typical of a solid signal, the CTRx pins take the signal as ENABLED. If the counter counts down from 100% to < 30% of its full range, which takes about 7-ms typical of a solid signal, the CTRx pins take the signal as DISABLED. From a 0 count counter (solid DISABLE), a solid ENABLE signal takes about t_{CTRDEG_ON} time to deglitch. From a 100% count (solid ENABLE), a solid DISABLE signal takes about t_{CTRDEG_OFF} time to deglitch. Although such a filter scheme provides a certain level of noise tolerance, it is highly recommended to shield the CTRx traces and keep the traces as short as possible in the PCB layout design. The CTRx deglitch time will add onto the FET response timing on OV, UV, and OW faults in a stack configuration. The t_{CTRDEG_OFF} time adds an additional delay to the fault detection timing and the t_{CTRDEG_ON} time adds an additional delay to the fault recovery timing.

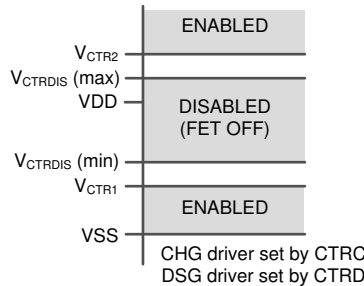

Figure 9-10. CTRC, CTRD Voltage Levels

9.3.12 Configuring 3-Series, 4-Series, or 5-Series Modes

The BQ77915 device supports 3-series, 4-series, or 5-series packs. To avoid accidentally detecting a UV fault on unused (shorted) cell inputs, the device must be configured for the specific cell count of the pack. This is set with the configuration pin, CCFG, which is mapped as shown in [Table 9-7](#). The device periodically checks the CCFG status and takes t_{CCFG_DEG} time to detect the pin status.

Table 9-7. CCFG Configurations

CCFG	CONFIGURATION	CONNECT TO
$< V_{CCFG_L}$ for t_{CCFG_DEG}	3 cells	VSS
Within V_{CCFG_M} for t_{CCFG_DEG}	4 cells	AVDD
$> V_{CCFG_H}$ for t_{CCFG_DEG}	5 cells	Floating

The CCFG pin should be tied to the recommended net from [Table 9-7](#). The device compares the CCFG input voltage to the AVDD voltage and should never be set above the AVDD voltage. When the device configuration is for 5 series, leave the CCFG pin floating. The internal pin bias is approximately 33% of the AVDD voltage for 5-series configuration.

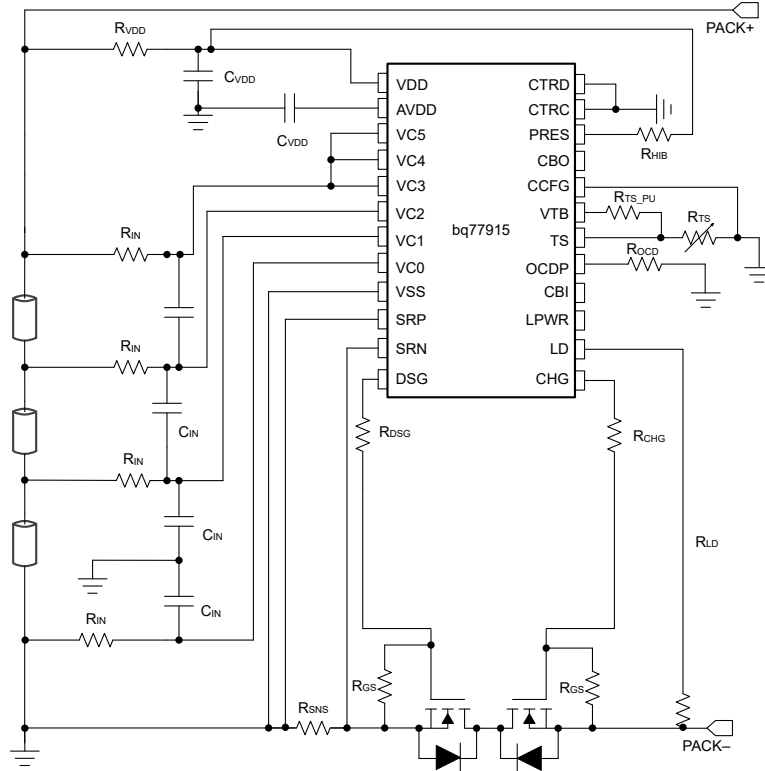

Figure 9-11. 3-Series Configuration with Cell Balancing and HIBERNATE Mode Disabled

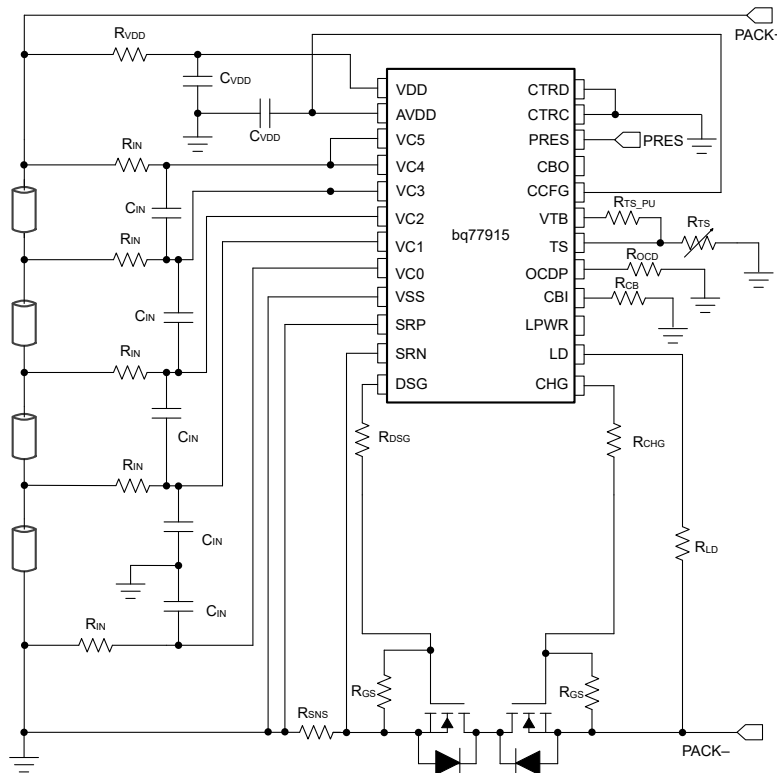

Figure 9-12. 4-Series Configuration with Internal Cell Balancing and HIBERNATE Mode Enabled

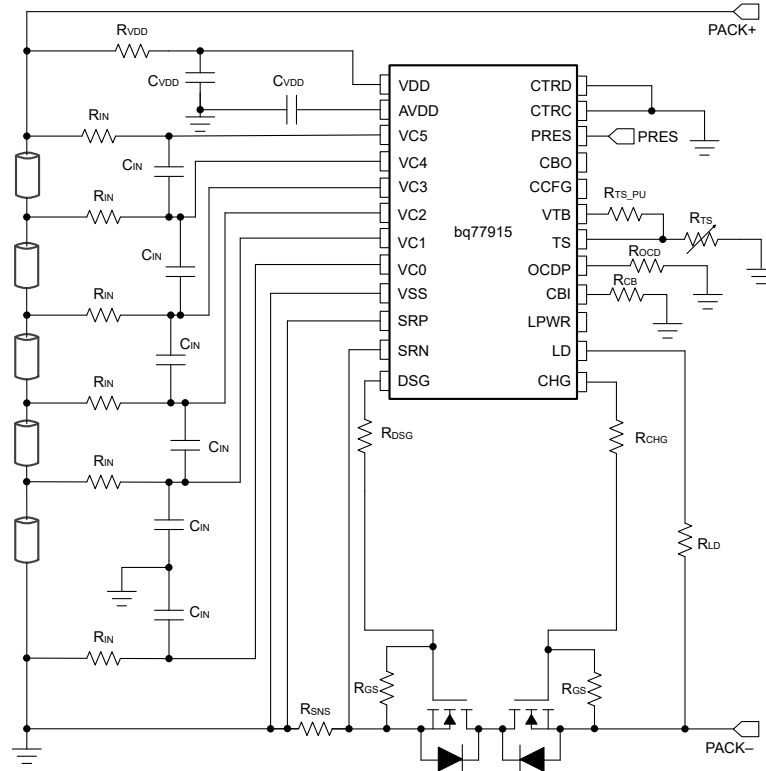

Figure 9-13. 5-Series Configuration with Internal Cell Balancing and HIBERNATE Mode Enabled

9.3.13 Stacking Implementations

To support higher than 5-series cell packs, daisy-chain multiple devices. Each device has OV, UV, OW, OTC, OTD, UTC, and UTD protections of its directly monitored cells, while any fault conditions disable the global CHG and/or DSG FET driver automatically.

Note

Upper devices do not provide OCC, OCD1, OCD2, or SCD protections, as these are based on pack current. For the BQ77915 device used on the upper stack, short the SRP and SRN pins to prevent false detection.

To configure higher-cell packs, follow this procedure:

- Connect each device on at least each of its three lowest cell input pins.
- Connect a higher cell count to the upper devices (for example, for a 7-series configuration, connect four cells on the upper device and three cells on the bottom device). This provides a stronger CTRx signal to the bottom device.
- Verify each device's CCFG pin is configured appropriately for its specific number of cells (that is, three, four, or five cells).
- Connect the upper CHG pins with an RCTR_x to the immediate lower device CTRC pin.
- Connect the upper DSG pins with an RCTR_x to the immediate lower device CTRD pin.
- All upper devices should have their SRP and SRN pins shorted to their VSS pins.
- Connect the upper CBI pins with an R_{CB} to the immediate lower device CBO pin.
- Connect the upper LPWR pins with an R_{HIB} to the immediate lower device PRES pin.
- Connect the upper OCDP pins with a 10-MΩ resistor to VSS. Use the lower OCDP pin to program the OCD1/2 delay.

9.4 Device Functional Modes

9.4.1 Power Modes

9.4.1.1 Power On Reset (POR)

The device powers up when $V_{DD} \geq V_{POR}$. At POR, the following events occur:

- A typical of 5-ms hold-off delay applies to both CHG and DSG drivers, keeping both drivers in the OFF state. This is to provide time for the internal LDO voltage to ramp up.
- The CTRC and CTRD deglitch occurs. During the deglitch time, the CHG and DSG driver remains off. Note that the deglitch time masks out the 5-ms hold-off delay.
- The device assumes an OV fault at POR; thus, the CHG driver is off for OV recovery time if all the cell voltages are $< (V_{OV} - V_{HYS_OV})$. The OV recovery time starts after the 5-ms hold-off delay. If device reset occurs when any cell voltage is above the OV hysteresis range, the CHG driver will remain off until an OV recovery condition is met.

9.4.1.2 NORMAL Mode

This is the normal operation mode. All configured protections are active, no fault is detected, and both CHG and DSG drivers are enabled. HIBERNATE mode is deactivated. While the device is in NORMAL mode, cell balancing occurs if all the necessary conditions for balancing are valid. Refer to the [Cell Balancing](#) section for details.

9.4.1.3 FAULT Mode

If any configured protection fault is detected, the device enters the FAULT mode. In this mode, the CHG and/or DSG driver can be turned off depending on the fault. Refer to [Fault Condition, State, and Recovery Methods](#) for details. When one of the FET drivers (either CHG or DSG) is turned off, while the other FET driver is still on, the state comparator is activated for FET body diode protection.

9.4.1.4 HIBERNATE Mode

If the PRES pin is left floating, the device enters HIBERNATE mode operation. In this mode, all fault detection and cell balancing is deactivated and the CHG and DSG drivers are turned off to reduce power consumption to ultra-low levels. This mode of operation is recommended when the battery packs are in shipping or storage. The device can be brought back to NORMAL mode by driving PRES high.

9.4.1.5 SHUTDOWN Mode

This is the lowest power consumption state of the device when V_{DD} falls below V_{SHUT} . In this mode, all fault detections, CHG and DSG drivers are disabled. The device will wake up and enter NORMAL mode when V_{DD} rises above V_{POR} .

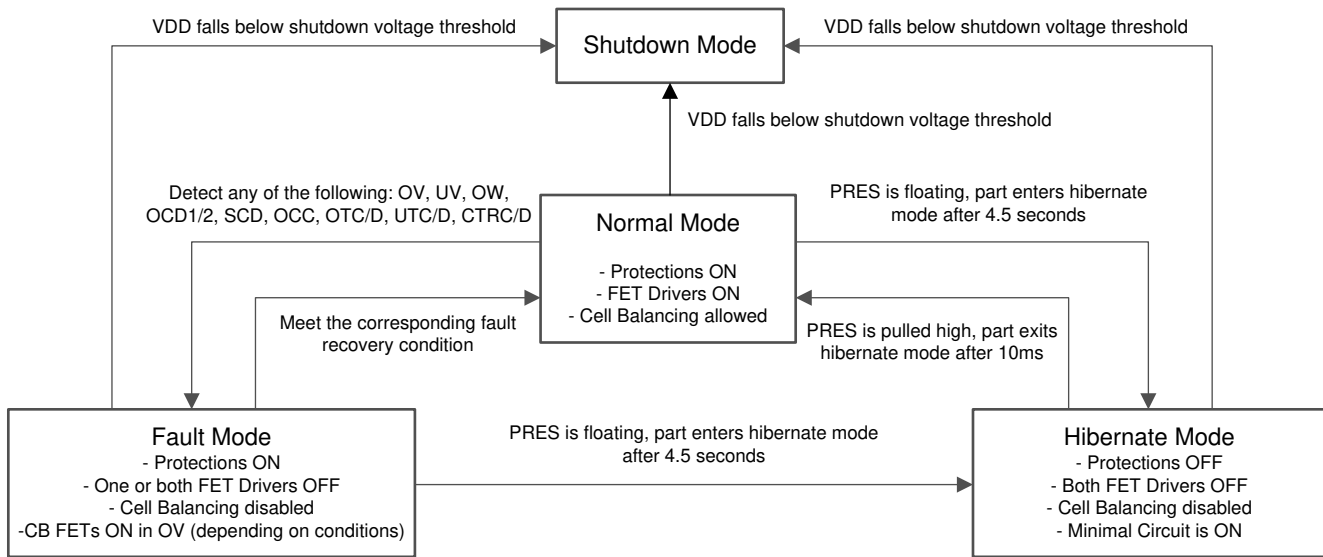

Figure 9-15. Various Operational Modes

9.4.1.6 Customer Fast Production Test Modes

The BQ77915 device supports the ability to greatly reduce production test time by cutting down on protection fault delay times. To shorten fault times, place the BQ77915 device into Customer Test Mode (CTM). CTM is triggered by raising VDD to V_{CTM} voltage above the highest cell input pin (that is, VC5) for t_{CTM_ENTRY} time.

The CTM is expected to be used in single-chip designs only. CTM is not supported for stacked designs. Once the device is in CTM, all fault delays and non-current fault's recovery delay times reduce to a value of t_{CTM_DELAY} . The fault recovery time for overcurrent faults (OCD1, OCD2, OCC, and SCD) is reduced to $t_{CTM_OC_REC}$.

Verification of protection fault functionality can be accomplished in a reduced timeframe in CTM. Reducing the VDD voltage to the same voltage applied to the highest-cell input pin for t_{CTM_ENTRY} will exit CTM.

In CTM, with reduced time for all internal delays, qualification of all faults will be reduced to a single instance. Thus, in this mode, fault-condition qualification is more susceptible to transients, so take care to have fault conditions clearly and cleanly applied during test mode to avoid false triggering of fault conditions during CTM.

10 Application and Implementation

Note

Information in the following applications sections is not device of the TI component specification, and TI does not warrant its accuracy or completeness. TI's customers are responsible for determining suitability of components for their purposes. Customers should validate and test their design implementation to confirm system functionality.

10.1 Application Information

The BQ77915 device is a low power stackable battery pack protector with integrated low-side NMOS FET drivers. The device protects and recovers without MCU control. The following sections highlight implementations for the BQ77915 device.

10.1.1 Recommended System Implementation

10.1.1.1 CHG and DSG FET Rise and Fall Time

The CHG and DSG FET drivers are designed to have fast switching time. Customers should select a proper gate resistor (R_{CHG} and R_{DSG} in the reference schematic) to set to the desired rise/fall time.



Figure 10-1. Select Proper Gate Resistor for FET Rise and Fall Time

The CHG FET fall time is generally slower because it is connected to the PACK- terminal. The CHG driver will pull to V_{SS} quickly when the driver is signaled to turn off. Once the gate of the CHG FET reaches ground or V_{gsth} , the PACK- will start to fall below ground, the CHG signal will follow suit in order to turn off the CHG FET. This portion of the fall time is strongly dependent on the FET characteristic, the number of FETs in parallel, and the value of the gate-source resistor (R_{GS_CHG}).

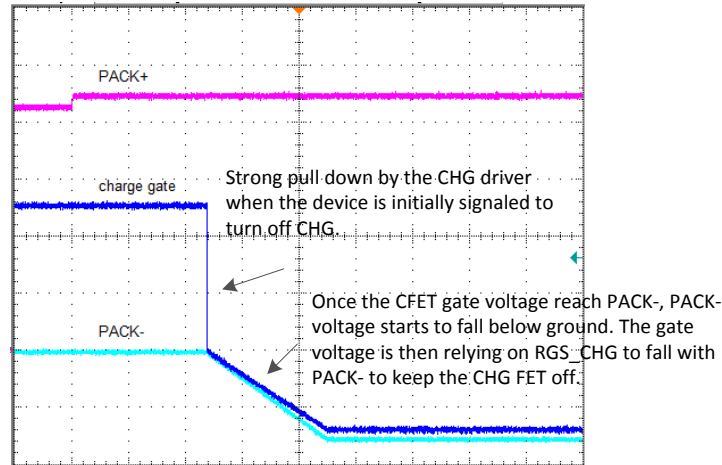

Figure 10-2. CHG FET Fall Time

10.1.1.2 Protecting CHG and LD

Because both CHG and LD are connected to PACK– terminal, these pins are specially designed to sustain an absolute max of –30 V. The device can be used in a wide variety of applications, and it is possible to expose the pins lower than –30-V absolute max rating.

To protect the pins, TI recommends to put a PMOS FET in series of the CHG pin, and a diode in series of the LD pin, as shown below.

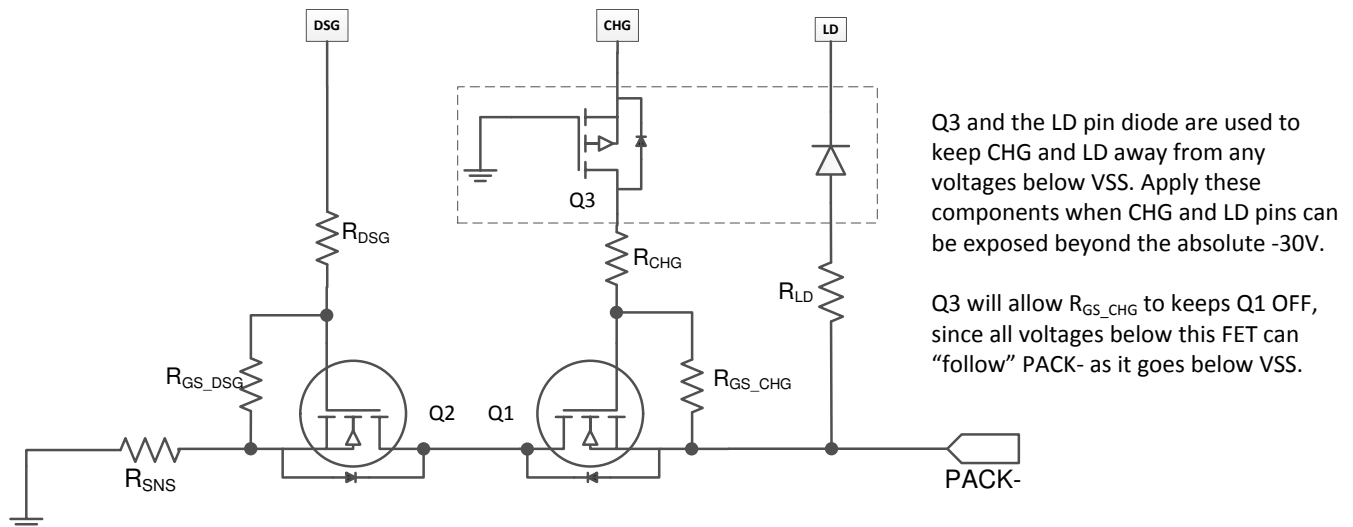

Figure 10-3. Protecting the CHG and LD Pins Below Absolute Minimum

10.1.1.3 Protecting the CHG FET

When the CHG driver is off, CHG is pulled to V_{SS} , the PACK– terminal can be pulled up to the PACK+ level when a load is connected. This can put the gate-source voltage above the absolute max of the MOSFET rating. Thus, it is common to place a Zener diode across the CHG FET's gate source to protect the CHG FET. Additional components are added when a Zener is used to limit current going into the CHG pin, as well as reducing the impact on rise time. See [Figure 10-4](#) for details.

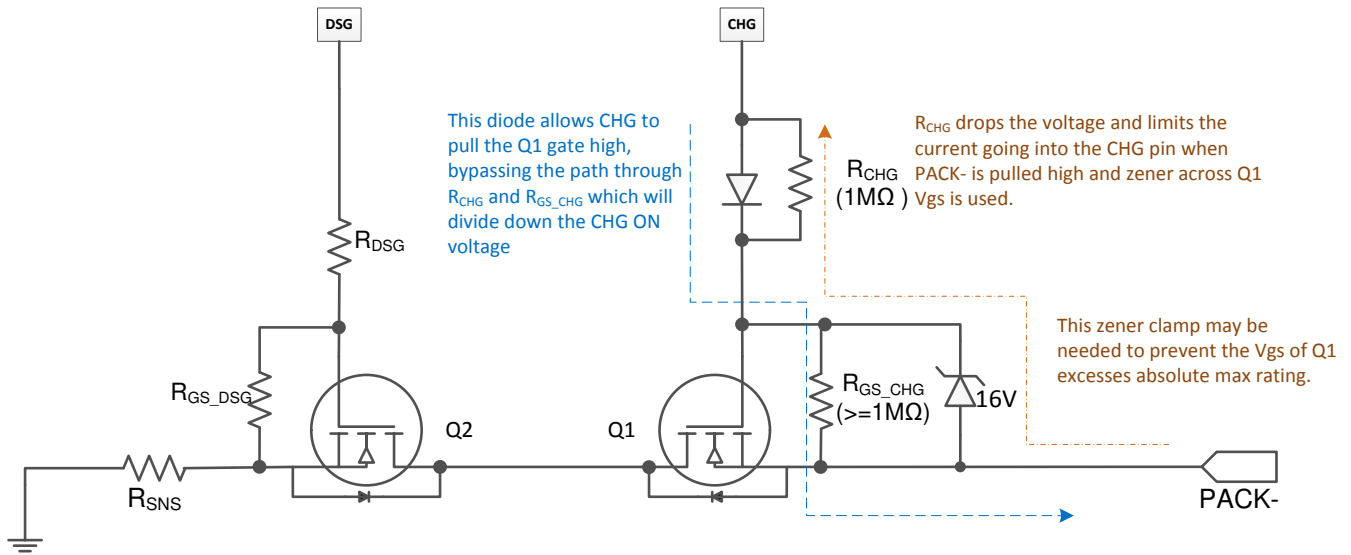

Figure 10-4. Protecting the CHG FET from High Voltage on PACK-

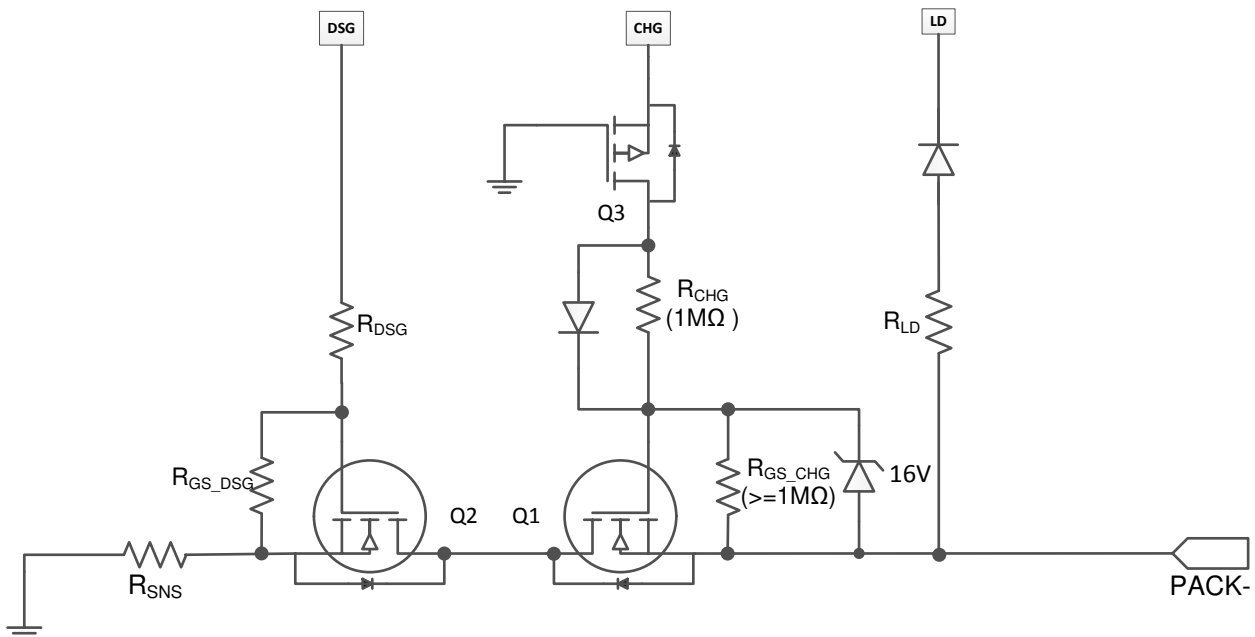

Figure 10-5. Optional Components Combining and Protections

10.1.1.4 Using Load Detect for UV Fault Recovery

A larger CHG FET gate-source resistor is required if load removal is enabled as a device of the UV recovery criteria. When the load removal circuit is enabled, the device is internally connected to V_{SS} . Because in a UV fault, the CHG driver remains on, it creates a resistor divider path to the load detect circuit.

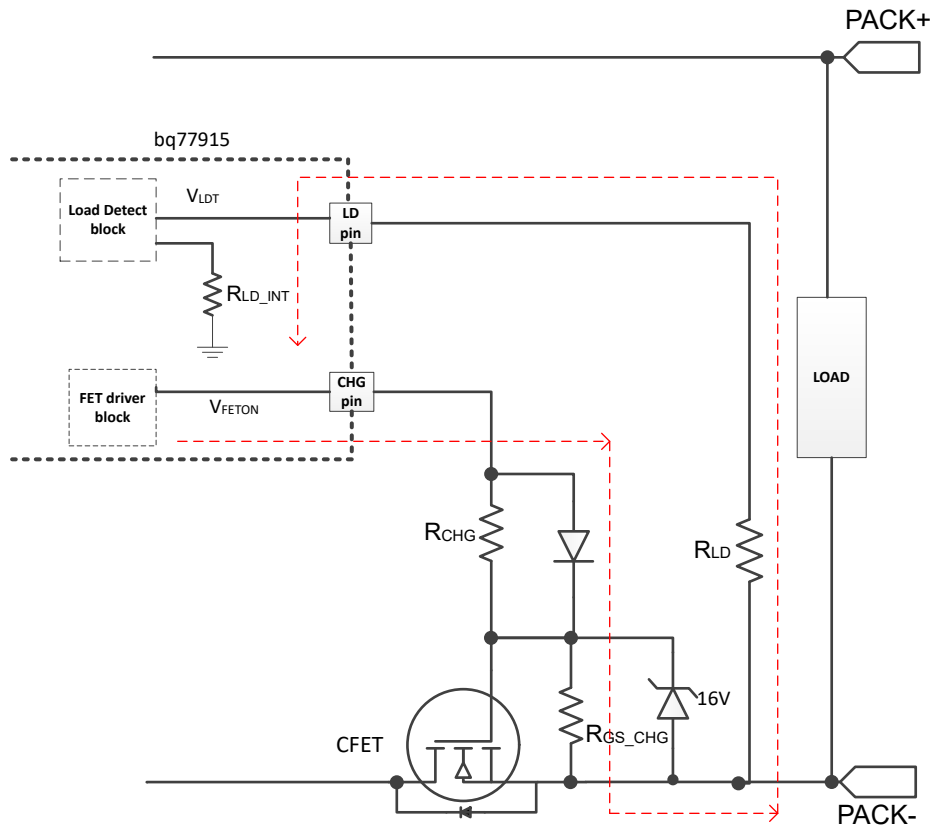

Figure 10-6. Load Detect Circuit During UV Fault

To verify load removal is detected properly during a UV fault, use $3.3\text{ M}\Omega$ for R_{GS_CHG} (instead of a typical $1\text{ M}\Omega$ when load removal is not required for UV recovery). R_{CHG} can stay in $1\text{ M}\Omega$ as recommended when using CHG FET protection components. The CHG FET rise time impact is minimized, as described in [Protecting the CHG FET](#). On a stacked configuration, connect the LD pin as shown in [Figure 10-7](#) if load removal is used for a UV fault recovery. If load detection is not required for a UV fault recovery, a larger value of R_{GS_CHG} can be used (that is, $10\text{ M}\Omega$), and the LD pin on the upper devices can be left floating.

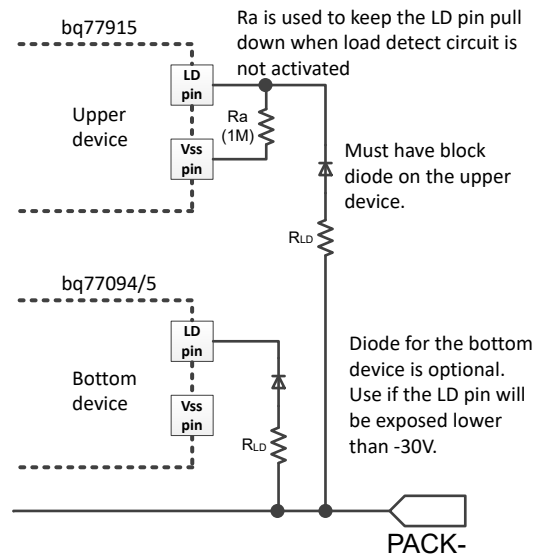

Figure 10-7. Simplified Circuit: LD Connection on Upper Device When Using for UV Fault Recovery

10.1.1.5 Temperature Protection

The device detects temperature by checking the voltage divided by R_{TS_PU} and R_{TS} , with the assumption of using $10\text{ K}\Omega$ R_{TS_PU} and 103AT NTC for R_{TS} . System designers should always check the thermistor resistance characteristic and refer to the temperature protection threshold specification in the *Electrical Characteristics* table to determine if a different pull up resistor should be used. If a different temperature trip point is required, it is possible to scale the threshold using this equation: Temperature Protection Threshold = $R_{TS}/(R_{TS} + R_{TS_PU})$.

Example: Scale OTC trip points from 50°C to 55°C

The OTC protection can be set to 45°C or 50°C . When the device's OTC threshold is set to 50°C , it is referred to configure the V_{OTC} parameter to 29.38% of V_{TB} (typical), with the assumption of $R_{TS_PU} = 10\text{ K}\Omega$ and $R_{TS} = 103\text{AT}$ or similar NTC (which the NTC resistance at $50^\circ\text{C} = 4.16\text{K}\Omega$). The V_{OTC} specification is the resistor divider ratio of R_{TS_PU} and R_{TS} .

The V_{OTC} , V_{OTD} , V_{UTC} , and V_{UTD} configuration options are fixed in the device. Hence, the actual temperature trip point can only adjust by using a different B-value NTC and/or using a different R_{TS_PU} .

In this example, the 103AT NTC resistance at 55°C is $3.536\text{ K}\Omega$. By changing the R_{TS_PU} from $10\text{ K}\Omega$ to $8.5\text{ K}\Omega$, we can scale the actual OTC temperature trip point from 50°C to 55°C . Because the R_{TS_PU} value is smaller, this change affects all the other temperature trip points and scales OTD, UTC, and UTD with the largest impact to OTD.

10.1.1.6 Adding RC Filters to the Sense Resistor

Current fault is sensed through voltage across sense resistor. Optional RC filters can be added to the sense resistor to improve stability.

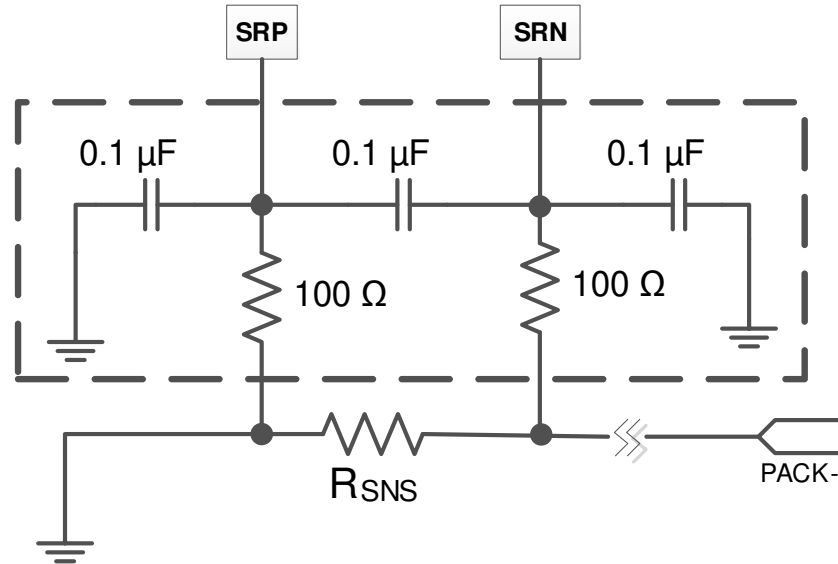

Figure 10-8. Optional Filters Improve Current Measurement

10.1.1.7 Using the State Comparator in an Application

The state comparator has built-in hysteresis and t_{STATE} qualification time. In a typical application, the sense resistor is selected according to the application current, which is not usually close to the state comparator threshold. Current variation slowly through the hysteresis range causes the FET body diode protection to toggle on and off.

10.1.1.7.1 Examples

As an example, using a 5-Ah battery, with 1C-rate (5 A) charge and 2C-rate (10 A) discharge, the sense resistor is mostly 3 mΩ or less.

The typical current to turn on the FET body diode protection is 625 mA using this example. The typical current to turn off the FET body diode protection with the 3-mΩ sense resistor is 417 mA. Using this example, a > 1 A current, either charge or discharge should provide a solid FET body diode protection detection. A momentary drop through the hysteresis threshold will not cause the body diode protection to drop, but drops of 2 ms or more will cause the FET to toggle.

Observe the device behavior during an OV event (and no other fault is detected). In an OV event, the CHG FET is off and the DSG FET is on. If a discharge of >1 A occurs, the device would turn on the CHG FET to allow the full discharge current to pass through. Once the overcharged cell is discharged to the OV recovery level, the OV fault is recovered and CHG driver turns on (or remains on in this scenario) and the state comparator is turned off.

If the discharge current drops below the $V_{(\text{STATE_D_HYS})}$ threshold for longer than t_{STATE} when the device is still in an OV fault, the CHG FET may toggle on and off until the overcharged cell voltage is reduced down to the OV recovery level. When the OV fault is recovered, the CHG FET will be turned on solidly and the state comparator is off.

Without the FET body diode protection, if a discharge occurs during an OV fault state, the discharge current can only pass through the CHG FET body diode until the OV fault is recovered. This increases the risk of damaging the CHG FET if the MOSFET is not rated to sustain such current through its body diode. It also increases the FET temperature as current is now carried through the body diode.

10.2 Typical Application

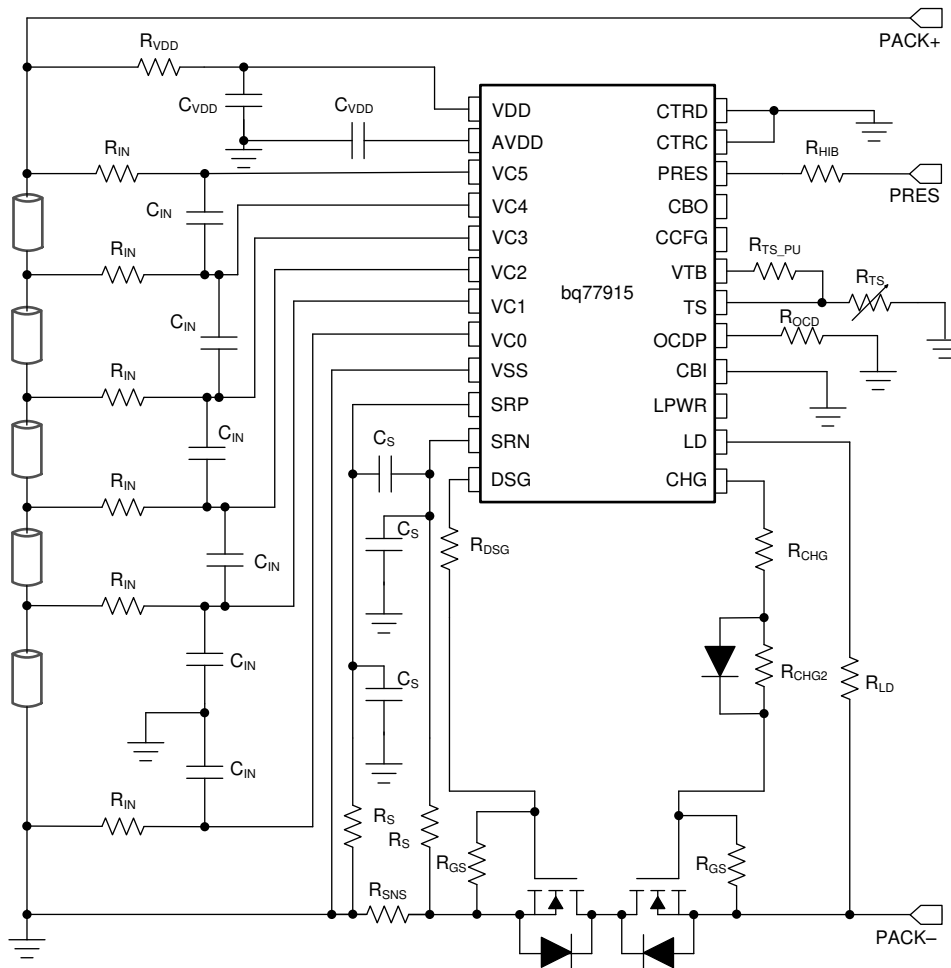

Figure 10-9. The BQ77915 Device with Five Cells

10.2.1 Design Requirements

For this design example, use the parameters shown in Table 10-1.

Table 10-1. Design Parameters

PARAMETER	DESCRIPTION	VALUES	
R_{IN}	Cell voltage sensing (VCx pins) filter resistor. System designers should change this parameter to adjust the cell balance current.	1 k Ω \pm 5%	
C_{IN}	Cell voltage sensing (VCx pins) filter capacitor	0.1 μ F \pm 10%	
R_{VDD}	Supply voltage filter resistor	1 k Ω \pm 5%	
C_{VDD}	Supply voltage filter capacitor	1 μ F \pm 20%	
R_S	Current sensing input filter resistor	100 Ω \pm 5%	
C_S	Current sensing input filter capacitor	0.1 μ F \pm 10%	
R_{TS}	NTC thermistor	103AT, 10 k Ω \pm 3%	
R_{TS_PU}	Thermistor pullup resistor to VTB pin, assuming using 103AT NTC or NTC with similar resistance-temperature characteristic	10 k Ω \pm 1%	
R_{GS_CHG}	CHG FET gate-source resistor	Load removal is enabled for UV recovery.	3.3 M Ω \pm 5%
		Load removal is disabled for UV recovery.	1 M Ω \pm 5%
R_{GS_DSG}	DSG FET gate-source resistor	1 M Ω \pm 5%	

Table 10-1. Design Parameters (continued)

PARAMETER	DESCRIPTION		VALUES
R _{CHG}	CHG gate resistor	System designers should adjust this parameter to meet the desired FET rise/fall time.	1 kΩ ±5%
		If additional components are used to protect the CHG FET and/or to enable load removal detection for UV recovery	1 MΩ ±5%
R _{DSG}	DSG gate resistor. System designers should adjust this parameter to meet the desired FET rise/fall time.		4.5 kΩ ±5%
R _{CTRC} and R _{CTRD}	CTRC and CTRD current limit resistor		10 MΩ ±5%
R _{HIB}	PRES pullup resistor for NORMAL mode		10 kΩ ±5%
R _{OCD}	OCDP discharge overcurrent protection delay pulldown resistor. System designers should change this parameter for the desired delay.		100 kΩ ±1%
R _{CB}	CBI pulldown resistor between stacked devices to enable balancing		10 kΩ ±5%
R _{LD}	LD resistor for load removal detection		450 KΩ ±5%
R _{SNS}	Current sense resistor for current protection. System designers should change this parameter according to the application current protection requirement.		1 mΩ ±1%

10.2.2 Detailed Design Procedure

The following is the detailed design procedure:

1. Select the number of devices needed for the number of cells in the system, and for the configuration of the protection thresholds.
2. Select the proper sense resistor value based on the application current. The sense resistor should enable detection of the highest current protection, as well as the short circuit current.
3. Set the temperature protection using a 103AT NTC (or an NTC with similar specifications). If using a different type of NTC, a different R_{TS_PU} may be used for the application. Refer to the actual temperature detection threshold voltage to determine the R_{TS_PU} value.
4. Connect the CCFG pin correctly for each device based on the number of cells in series.
5. Enable cell balancing if desired.
6. Select the configuration parameters and input filter resistors to set the current.
7. Review the [Recommended System Implementation](#) to determine if optional components should be added to the schematic.

10.2.2.1 Design Example

This example shows how to design protection for an 18-V Li-ion battery pack using 4.2-V cells with the following requirements:

- The system operates from 15 V to 21.5 V.
- The battery allows 4-A continuous current.
- The battery protects with 8-A discharge current > 500 ms.
- The battery has short circuit protection in < 2 ms.
- The system is for operation in an office environment: 10°C to 30°C.
- The cell normal charge voltage is 4.2 ±0.05 V to 0.05 C.
- The cell cutoff voltage is 2.75 V.
- The charge temperature is 0°C to 45°C.
- A cell configuration is selected to provide 5 Ah over the system range of operation.
- The cell assembly is capable of > 30-A short circuit current.
- Cell balancing is desired with a current of 10% of termination current.
- Low current drain is desired when the pack is removed from the system.
- Load removal for fault recovery is required. Recovery by connecting the charger is acceptable.

To start the design:

1. Start the schematic:
 - An 18-V pack using 3.6-V nominal cells requires a 5-series configuration. A single BQ77915 device is needed.

- Follow the 5-series reference schematic in this document. Follow the recommended design parameters in [Design Requirements](#).
 - Because a single device is needed, CTRC and CTRD are connected directly to GND.
 - The power FET used in this type of application usually has an absolute maximum of 20-V Vgs. For an 18-V pack design, transient voltage during an OCD may exceed 20 V, so the diode across the 1-M Ω R_{CHG2} is used. R_{CHG} helps to slow the charge FET from turning on.
 - Because a charger connection for UV recovery is acceptable, the condition in [Using Load Detect for UV Fault Recovery](#) is not a concern. A 1-M Ω R_{GS_CHG} can be used for the schematic.
 - The optional sense input filter is selected for the circuit.
 - Because low current storage is desired, the PRES pin is brought out of the pack for control by the system. The standard recommended R_{HIB} value is used.
 - Because cell balancing is required:
 - Connect the CBI pin to VSS.
 - Determine the resistance for the R_{IN} filter resistors. Since the charge taper current will be 0.05 \times 5 A or 250 mA, 10% is 25 mA. With a 4.1-V cell, 25 mA would require 164- Ω resistance. This resistance includes the internal R_{BAL} resistance and two R_{IN} resistors. 75- Ω resistors are selected for R_{IN}.
2. Decide the value of the sense resistor, R_{SNS}.
- When selecting the value of R_{SNS}, verify the voltage drop across SRP and SRN is within the available current protection threshold range.
 - In this example, only one protection threshold is specified. The minimum available OCD threshold is the –10-mV OCD1 threshold, but this would result in an odd value for R_{SNS} and the tolerance of the threshold is 30%. Using the –60-mV threshold of the BQ77915 configuration, a 10-m Ω sense resistor would give a 6-A nominal OCD threshold. With the 20% tolerance, 4 A can pass without OCD and 8 A will always cross the threshold.
 - A 30-A SCD with a 10-m Ω sense resistor would be a nominal 300-mV threshold. Tolerance must be considered and the protection threshold can be lower than the battery capability. The 120-mV threshold of the BQ77915 configuration with a 10-m Ω R_{SNS} will give a 12-A nominal short circuit threshold.
 - Select R_{SNS} = 10 m Ω for this example.
3. Determine the remaining BQ77915 protection configuration:
- Charging the cells at a lower than maximum voltage allows a margin on setting the OV threshold. The system could allow a 4.15-V OV, while the cells might allow a 4.3-V OV. Since the charge voltage will be 4.1 V/cell, this is the desired VFC point of the BQ77915 device. The 4200-mV OV threshold and 100 mV VOV – VFC of the BQ77915 device are suitable.
 - OV hysteresis and delay values are not specified requirements. A 1-s delay will be selected. Some hysteresis is desired to prevent cycling if the battery were to reach OV. 200 mV is acceptable.
 - The system will stop operation at a nominal 3 V per cell, while the cells could operate to 2.75 V. Some margin below the 3 V should be allowed, because cell voltages possibly vary at low states of charge. A 2750-mV threshold option is available, but the existing BQ77915 configuration has the 2900 threshold.
 - UV hysteresis and delay are not specified requirements. A 1-s delay is selected. Generally, a larger UV hysteresis will avoid system cycling from automatic recovery; however, in this design load, removal is required and charger connection is expected for UV recovery. The value could vary, but 400 mV is selected.
 - Open-wire protection is selected at the 100-nA level.
 - t_{OCD1} or t_{OCD2} could be programmed to 350 ms to protect in less than 500 ms, or the default BQ77915 180 ms is used. However, the 350 ms can be selected with R_{OCD}. Use 604 k Ω 1% for R_{OCD}.
 - The 2-ms SCD response time allows either SCD delay selection.
 - Overcurrent charge protection is not specified in the requirements. The BQ77915 60-mV setting will allow a 1C charge.
 - For temperature protections, the 0°C to 45°C charge temperature thresholds match the range for the cells. Use the lower range for discharge.
 - The VCBTH – VCBTHL determines the voltage spread during constant current charge when balancing is allowed. 100 mV allows some spread without balancing.
 - See the summary in [Table 10-2](#).

4. Review the available release in the [Device Comparison Table](#) to determine if it is a suitable option. In this example, the BQ7791500 configuration is suitable. If it is not suitable for your design, contact a TI representative for further assistance and for information on BQ77915 PRODUCT PREVIEW devices.

Table 10-2. Design Example Configuration

Protection	Threshold	Hysteresis	Delay	Recovery Method
OV	4.2 V	200 mV	1 s (default setting)	Hysteresis
UV	2.9 V	400 mV	1 s (default setting)	Hysteresis + load removal
OW	100 nA (default setting)	—	—	$(V_{C_x} - V_{C_{x-1}}) > 600 \text{ mV}$ (typical)
OCD1	60 mV	—	180 ms	Load removal only
OCD2	60 mV	—	180 ms (350 ms using R_{OCD})	Load removal only
SCD	120 mV	—	960 μs	Load removal only
OCC	60 mV	—	Fixed at 10 ms	Load detection only
OTC	45°C	10°C	4.5 s	Hysteresis
OTD	65°C	10°C	4.5 s	Hysteresis
UTC	0°C	10°C	4.5 s	Hysteresis
UTD	-10°C	10°C	4.5 s	Hysteresis
VOV – VFC	100 mV	—	—	—
VCBTH – VCBTL	100 mV	—	—	—
V_{START}	3.8 V	—	—	—

10.2.3 Application Curves

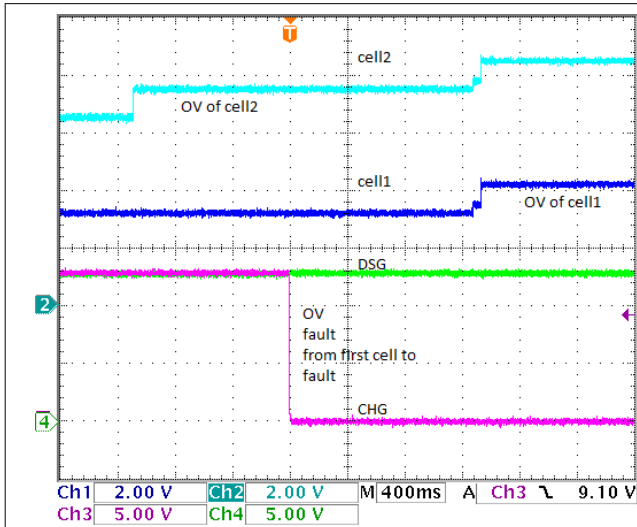

Figure 10-10. OV Fault Protection

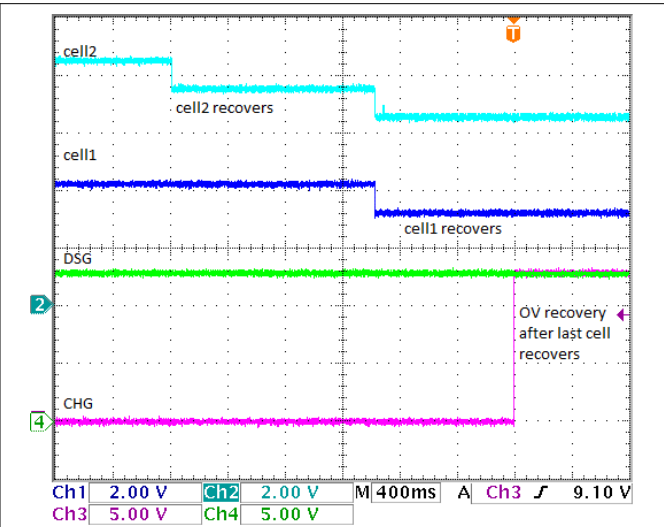

Figure 10-11. OV Fault Recovery

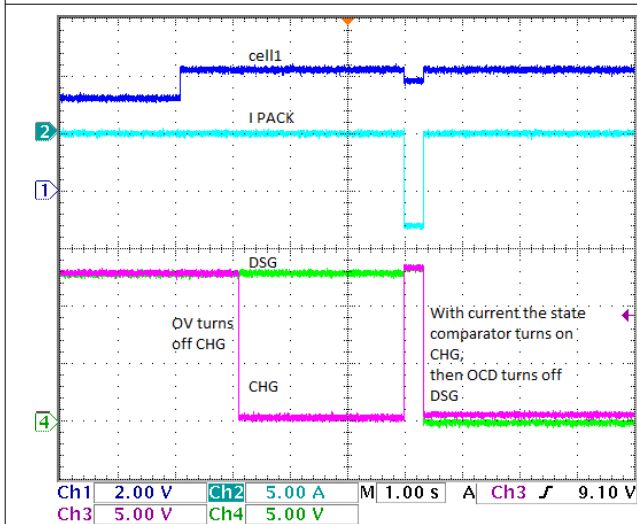

Figure 10-12. OV and OCD2 Faults Protection

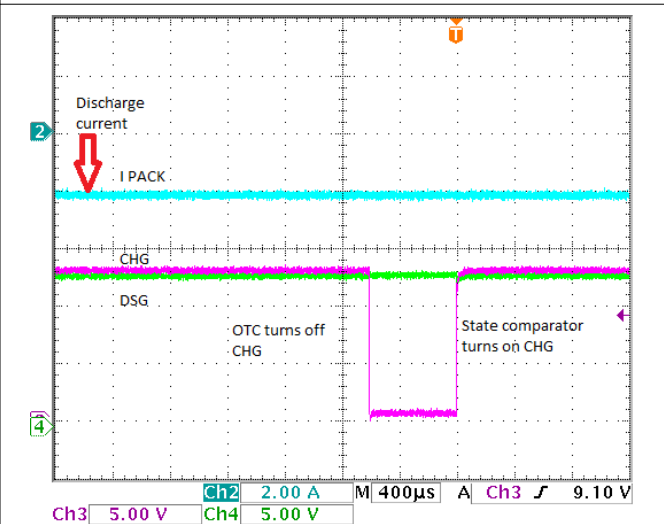
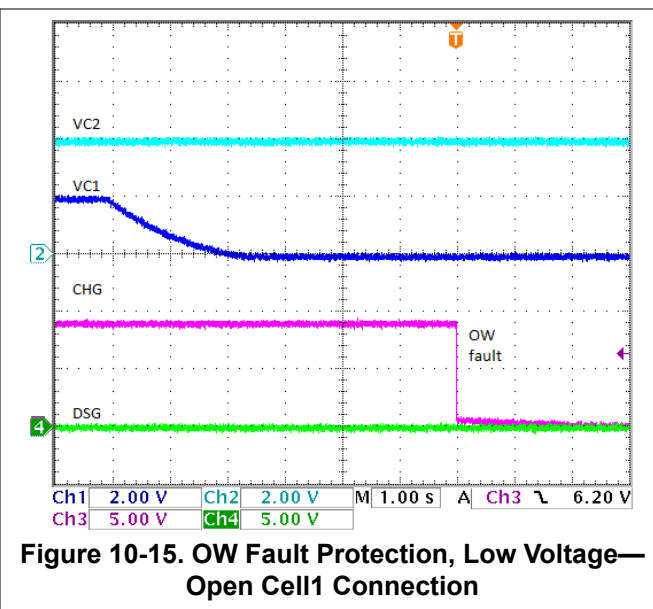
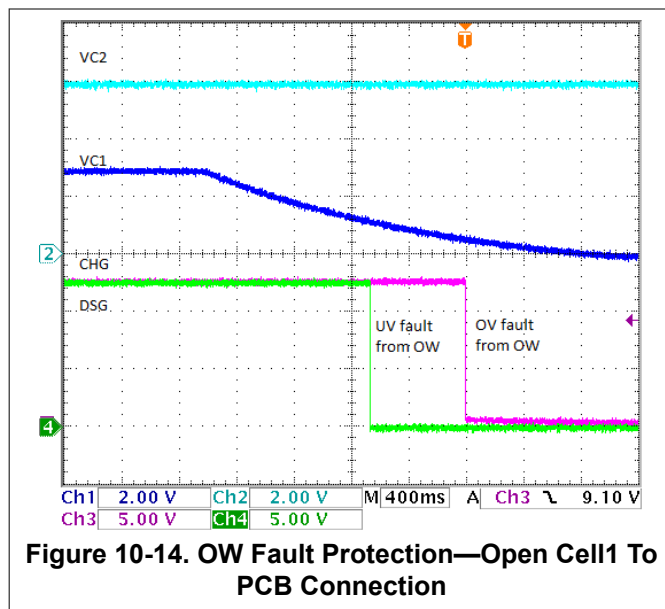

Figure 10-13. Detect OTC Fault While in Discharge



11 Power Supply Recommendations

The recommended cell voltage range is up to 5 V. If three cells in series are connecting to the BQ77915 device, the unused VCx pins should be shorted to the highest unused VCx pin. The recommended VDD range is from 3 V to 25 V. This implies the device is still operational when cell voltage is depleted down to the ~1.5-V range.

12 Layout

12.1 Layout Guidelines

1. Match SRN and SRP traces.
2. R_{IN} filters, VDD, AVDD filters, and the C_{VDD} capacitor should be placed close to the device pins.
3. Separate the device ground plane (low current ground) from the high current path. Filter capacitors should reference to the low current ground path or device Vss.
4. In a stack configuration, the R_{CTRD} and R_{CTRC} should be placed closer to the lower device CTRD and CTRC pins.
5. R_{GS} should be placed near the FETs.
6. In a stacked configuration, verify in the PCB layout that the trace from the VC5 pin to a cell and the trace from the VC0 pin of the next upper device to the immediately higher cell are kept separate.

12.2 Layout Example

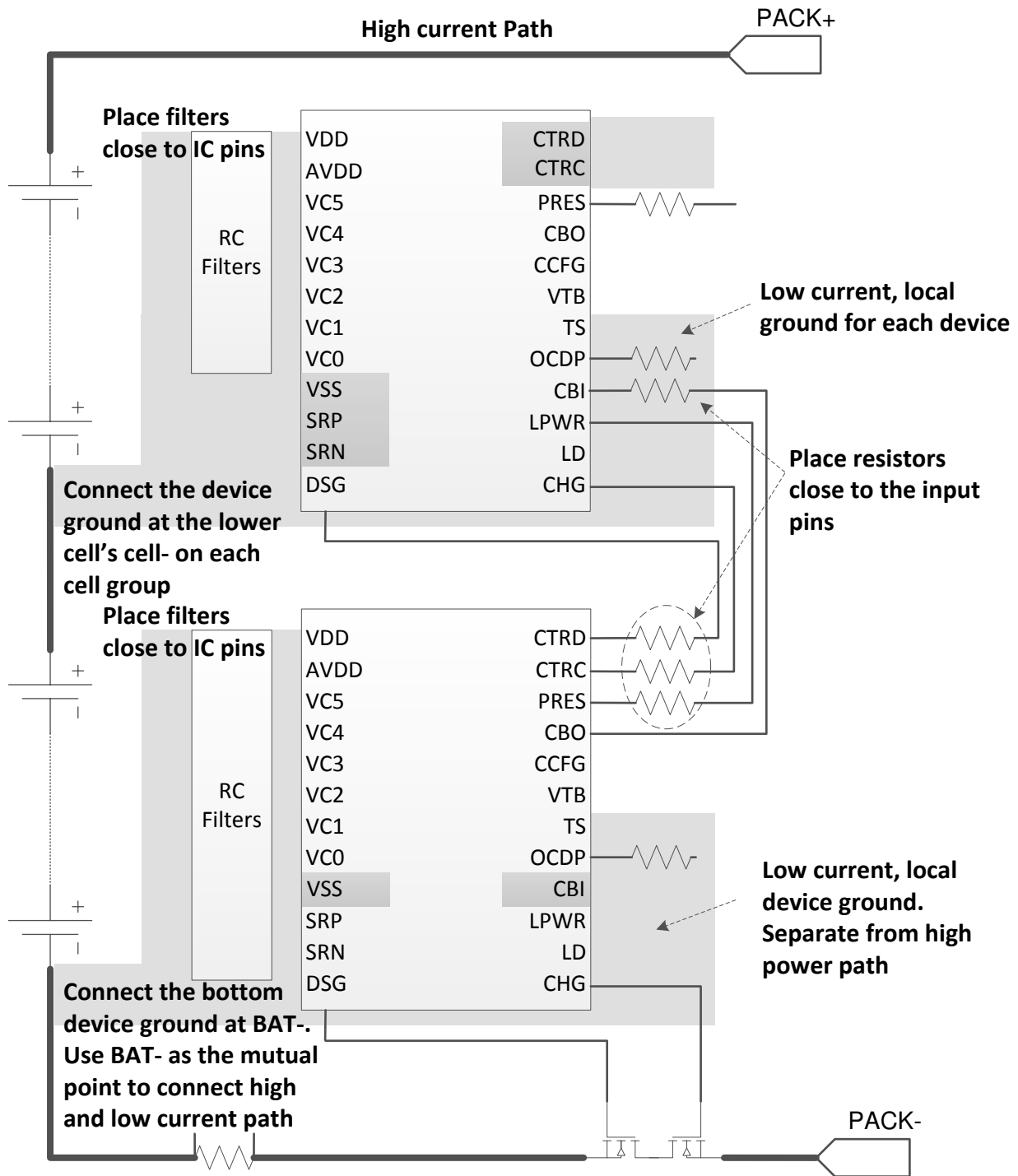

Figure 12-1. Layout Example

13 Device and Documentation Support

13.1 Third-Party Products Disclaimer

TI'S PUBLICATION OF INFORMATION REGARDING THIRD-PARTY PRODUCTS OR SERVICES DOES NOT CONSTITUTE AN ENDORSEMENT REGARDING THE SUITABILITY OF SUCH PRODUCTS OR SERVICES OR A WARRANTY, REPRESENTATION OR ENDORSEMENT OF SUCH PRODUCTS OR SERVICES, EITHER ALONE OR IN COMBINATION WITH ANY TI PRODUCT OR SERVICE.

13.2 Documentation Support

13.2.1 Related Documentation

For related documentation see the following:

- [BQ77915 3–5S Low-Power Protector Evaluation Module User's Guide](#)
- [BQ77915 Functional Safety FIT Rate, FMD, and Pin FMA Application Report](#)

13.3 Receiving Notification of Documentation Updates

To receive notification of documentation updates, navigate to the device product folder on [ti.com](#). Click on *Subscribe to updates* to register and receive a weekly digest of any product information that has changed. For change details, review the revision history included in any revised document.

13.4 Support Resources

TI E2E™ [support forums](#) are an engineer's go-to source for fast, verified answers and design help — straight from the experts. Search existing answers or ask your own question to get the quick design help you need.

Linked content is provided "AS IS" by the respective contributors. They do not constitute TI specifications and do not necessarily reflect TI's views; see TI's [Terms of Use](#).

13.5 Trademarks

TI E2E™ is a trademark of Texas Instruments.
All trademarks are the property of their respective owners.

13.6 Electrostatic Discharge Caution



This integrated circuit can be damaged by ESD. Texas Instruments recommends that all integrated circuits be handled with appropriate precautions. Failure to observe proper handling and installation procedures can cause damage.

ESD damage can range from subtle performance degradation to complete device failure. Precision integrated circuits may be more susceptible to damage because very small parametric changes could cause the device not to meet its published specifications.

13.7 Glossary

[TI Glossary](#) This glossary lists and explains terms, acronyms, and definitions.

14 Mechanical, Packaging, and Orderable Information

The following pages include mechanical, packaging, and orderable information. This information is the most current data available for the designated devices. This data is subject to change without notice and revision of this document. For browser-based versions of this data sheet, refer to the left-hand navigation.

PACKAGING INFORMATION

Orderable part number	Status (1)	Material type (2)	Package Pins	Package qty Carrier	RoHS (3)	Lead finish/ Ball material (4)	MSL rating/ Peak reflow (5)	Op temp (°C)	Part marking (6)
BQ7791500PWR	Active	Production	TSSOP (PW) 24	2000 LARGE T&R	Yes	NIPDAU	Level-2-260C-1 YEAR	-40 to 85	BQ77915
BQ7791500PWR.A	Active	Production	TSSOP (PW) 24	2000 LARGE T&R	Yes	NIPDAU	Level-2-260C-1 YEAR	-40 to 85	BQ77915
BQ7791500PWT	Active	Production	TSSOP (PW) 24	250 SMALL T&R	Yes	NIPDAU	Level-2-260C-1 YEAR	-40 to 85	BQ77915
BQ7791500PWT.A	Active	Production	TSSOP (PW) 24	250 SMALL T&R	Yes	NIPDAU	Level-2-260C-1 YEAR	-40 to 85	BQ77915
BQ7791501PWR	Active	Production	TSSOP (PW) 24	2000 LARGE T&R	Yes	NIPDAU	Level-2-260C-1 YEAR	-40 to 85	7791501
BQ7791501PWR.A	Active	Production	TSSOP (PW) 24	2000 LARGE T&R	Yes	NIPDAU	Level-2-260C-1 YEAR	-40 to 85	7791501
BQ7791501PWT	Active	Production	TSSOP (PW) 24	250 SMALL T&R	Yes	NIPDAU	Level-2-260C-1 YEAR	-40 to 85	7791501
BQ7791501PWT.A	Active	Production	TSSOP (PW) 24	250 SMALL T&R	Yes	NIPDAU	Level-2-260C-1 YEAR	-40 to 85	7791501
BQ7791502PW	Active	Production	TSSOP (PW) 24	60 TUBE	Yes	NIPDAU	Level-2-260C-1 YEAR	-40 to 85	7791502
BQ7791502PW.A	Active	Production	TSSOP (PW) 24	60 TUBE	Yes	NIPDAU	Level-2-260C-1 YEAR	-40 to 85	7791502
BQ7791502PWR	Active	Production	TSSOP (PW) 24	2000 LARGE T&R	Yes	NIPDAU	Level-2-260C-1 YEAR	-40 to 85	7791502
BQ7791502PWR.A	Active	Production	TSSOP (PW) 24	2000 LARGE T&R	Yes	NIPDAU	Level-2-260C-1 YEAR	-40 to 85	7791502
BQ7791504PW	Active	Production	TSSOP (PW) 24	60 TUBE	Yes	NIPDAU	Level-2-260C-1 YEAR	-40 to 85	7791504
BQ7791504PW.A	Active	Production	TSSOP (PW) 24	60 TUBE	Yes	NIPDAU	Level-2-260C-1 YEAR	-40 to 85	7791504
BQ7791504PWR	Active	Production	TSSOP (PW) 24	2000 LARGE T&R	Yes	NIPDAU	Level-2-260C-1 YEAR	-40 to 85	7791504
BQ7791504PWR.A	Active	Production	TSSOP (PW) 24	2000 LARGE T&R	Yes	NIPDAU	Level-2-260C-1 YEAR	-40 to 85	7791504
BQ7791506PW	Active	Production	TSSOP (PW) 24	60 TUBE	Yes	NIPDAU	Level-2-260C-1 YEAR	-40 to 85	7791506
BQ7791506PW.A	Active	Production	TSSOP (PW) 24	60 TUBE	Yes	NIPDAU	Level-2-260C-1 YEAR	-40 to 85	7791506
BQ7791506PWR	Active	Production	TSSOP (PW) 24	2000 LARGE T&R	Yes	NIPDAU	Level-2-260C-1 YEAR	-40 to 85	7791506
BQ7791506PWR.A	Active	Production	TSSOP (PW) 24	2000 LARGE T&R	Yes	NIPDAU	Level-2-260C-1 YEAR	-40 to 85	7791506
BQ7791508PW	Active	Production	TSSOP (PW) 24	60 TUBE	Yes	NIPDAU	Level-2-260C-1 YEAR	-40 to 85	7791508
BQ7791508PW.A	Active	Production	TSSOP (PW) 24	60 TUBE	Yes	NIPDAU	Level-2-260C-1 YEAR	-40 to 85	7791508
BQ7791508PWR	Active	Production	TSSOP (PW) 24	2000 LARGE T&R	Yes	NIPDAU	Level-2-260C-1 YEAR	-40 to 85	7791508
BQ7791508PWR.A	Active	Production	TSSOP (PW) 24	2000 LARGE T&R	Yes	NIPDAU	Level-2-260C-1 YEAR	-40 to 85	7791508
BQ7791513PWR	Active	Production	TSSOP (PW) 24	2000 LARGE T&R	Yes	NIPDAU	Level-2-260C-1 YEAR	-40 to 85	7791513
BQ7791513PWR.A	Active	Production	TSSOP (PW) 24	2000 LARGE T&R	Yes	NIPDAU	Level-2-260C-1 YEAR	-40 to 85	7791513
BQ7791514PWR	Active	Production	TSSOP (PW) 24	2000 LARGE T&R	Yes	NIPDAU	Level-2-260C-1 YEAR	-40 to 85	7791514
BQ7791514PWR.A	Active	Production	TSSOP (PW) 24	2000 LARGE T&R	Yes	NIPDAU	Level-2-260C-1 YEAR	-40 to 85	7791514

(1) **Status:** For more details on status, see our [product life cycle](#).

(2) **Material type:** When designated, preproduction parts are prototypes/experimental devices, and are not yet approved or released for full production. Testing and final process, including without limitation quality assurance, reliability performance testing, and/or process qualification, may not yet be complete, and this item is subject to further changes or possible discontinuation. If available for ordering, purchases will be subject to an additional waiver at checkout, and are intended for early internal evaluation purposes only. These items are sold without warranties of any kind.

(3) **RoHS values:** Yes, No, RoHS Exempt. See the [TI RoHS Statement](#) for additional information and value definition.

(4) **Lead finish/Ball material:** Parts may have multiple material finish options. Finish options are separated by a vertical ruled line. Lead finish/Ball material values may wrap to two lines if the finish value exceeds the maximum column width.

(5) **MSL rating/Peak reflow:** The moisture sensitivity level ratings and peak solder (reflow) temperatures. In the event that a part has multiple moisture sensitivity ratings, only the lowest level per JEDEC standards is shown. Refer to the shipping label for the actual reflow temperature that will be used to mount the part to the printed circuit board.

(6) **Part marking:** There may be an additional marking, which relates to the logo, the lot trace code information, or the environmental category of the part.

Multiple part markings will be inside parentheses. Only one part marking contained in parentheses and separated by a "-" will appear on a part. If a line is indented then it is a continuation of the previous line and the two combined represent the entire part marking for that device.

Important Information and Disclaimer: The information provided on this page represents TI's knowledge and belief as of the date that it is provided. TI bases its knowledge and belief on information provided by third parties, and makes no representation or warranty as to the accuracy of such information. Efforts are underway to better integrate information from third parties. TI has taken and continues to take reasonable steps to provide representative and accurate information but may not have conducted destructive testing or chemical analysis on incoming materials and chemicals. TI and TI suppliers consider certain information to be proprietary, and thus CAS numbers and other limited information may not be available for release.

In no event shall TI's liability arising out of such information exceed the total purchase price of the TI part(s) at issue in this document sold by TI to Customer on an annual basis.

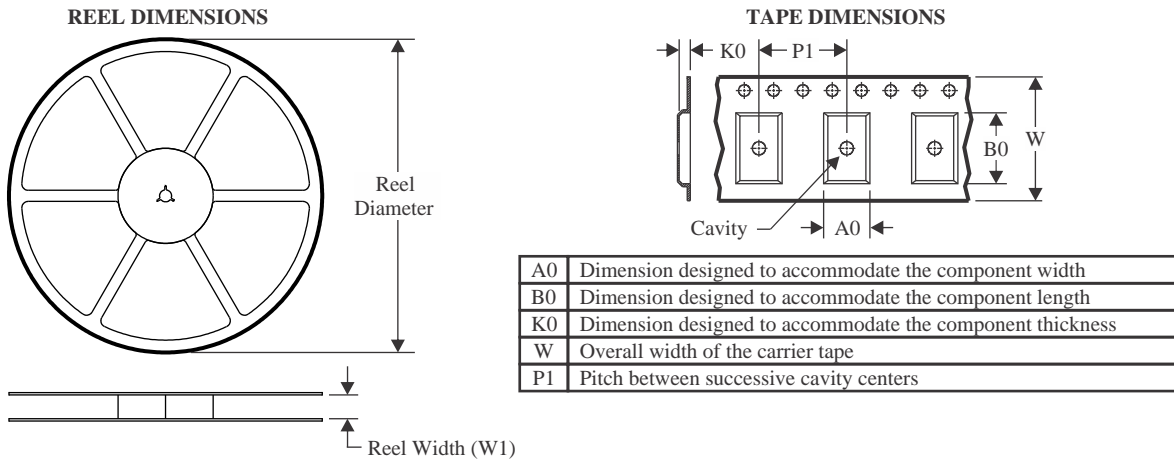
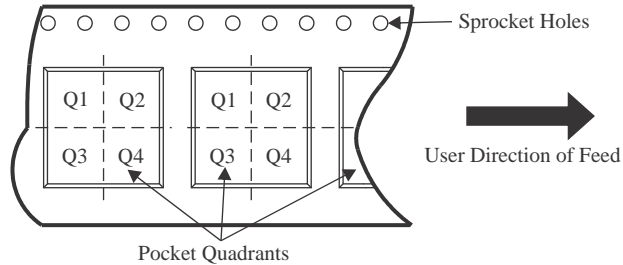
TAPE AND REEL INFORMATION

QUADRANT ASSIGNMENTS FOR PIN 1 ORIENTATION IN TAPE

*All dimensions are nominal

Device	Package Type	Package Drawing	Pins	SPQ	Reel Diameter (mm)	Reel Width W1 (mm)	A0 (mm)	B0 (mm)	K0 (mm)	P1 (mm)	W (mm)	Pin1 Quadrant
BQ7791500PWR	TSSOP	PW	24	2000	330.0	16.4	6.95	8.3	1.6	8.0	16.0	Q1
BQ7791500PWT	TSSOP	PW	24	250	180.0	16.4	6.95	8.3	1.6	8.0	16.0	Q1
BQ7791501PWR	TSSOP	PW	24	2000	330.0	16.4	6.95	8.3	1.6	8.0	16.0	Q1
BQ7791501PWT	TSSOP	PW	24	250	180.0	16.4	6.95	8.3	1.6	8.0	16.0	Q1
BQ7791502PWR	TSSOP	PW	24	2000	330.0	16.4	6.95	8.3	1.6	8.0	16.0	Q1
BQ7791504PWR	TSSOP	PW	24	2000	330.0	16.4	6.95	8.3	1.6	8.0	16.0	Q1
BQ7791506PWR	TSSOP	PW	24	2000	330.0	16.4	6.95	8.3	1.6	8.0	16.0	Q1
BQ7791508PWR	TSSOP	PW	24	2000	330.0	16.4	6.95	8.3	1.6	8.0	16.0	Q1
BQ7791513PWR	TSSOP	PW	24	2000	330.0	16.4	6.95	8.3	1.6	8.0	16.0	Q1
BQ7791514PWR	TSSOP	PW	24	2000	330.0	16.4	6.95	8.3	1.6	8.0	16.0	Q1

TAPE AND REEL BOX DIMENSIONS

*All dimensions are nominal

Device	Package Type	Package Drawing	Pins	SPQ	Length (mm)	Width (mm)	Height (mm)
BQ7791500PWR	TSSOP	PW	24	2000	353.0	353.0	32.0
BQ7791500PWT	TSSOP	PW	24	250	213.0	191.0	35.0
BQ7791501PWR	TSSOP	PW	24	2000	353.0	353.0	32.0
BQ7791501PWT	TSSOP	PW	24	250	213.0	191.0	35.0
BQ7791502PWR	TSSOP	PW	24	2000	353.0	353.0	32.0
BQ7791504PWR	TSSOP	PW	24	2000	353.0	353.0	32.0
BQ7791506PWR	TSSOP	PW	24	2000	353.0	353.0	32.0
BQ7791508PWR	TSSOP	PW	24	2000	353.0	353.0	32.0
BQ7791513PWR	TSSOP	PW	24	2000	353.0	353.0	32.0
BQ7791514PWR	TSSOP	PW	24	2000	353.0	353.0	32.0

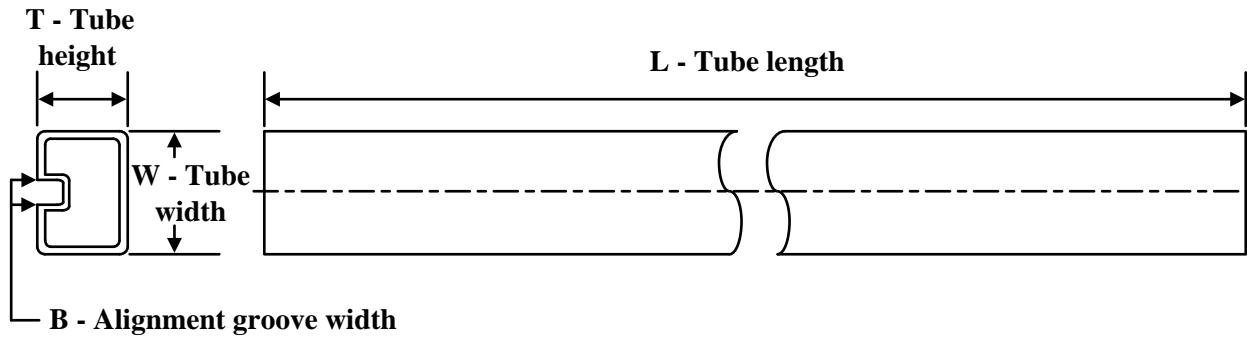
TUBE

*All dimensions are nominal

Device	Package Name	Package Type	Pins	SPQ	L (mm)	W (mm)	T (μm)	B (mm)
BQ7791502PW	PW	TSSOP	24	60	530	10.2	3600	3.5
BQ7791502PW.A	PW	TSSOP	24	60	530	10.2	3600	3.5
BQ7791504PW	PW	TSSOP	24	60	530	10.2	3600	3.5
BQ7791504PW.A	PW	TSSOP	24	60	530	10.2	3600	3.5
BQ7791506PW	PW	TSSOP	24	60	530	10.2	3600	3.5
BQ7791506PW.A	PW	TSSOP	24	60	530	10.2	3600	3.5
BQ7791508PW	PW	TSSOP	24	60	530	10.2	3600	3.5
BQ7791508PW.A	PW	TSSOP	24	60	530	10.2	3600	3.5

PW0024A

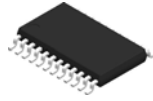

PACKAGE OUTLINE

TSSOP - 1.2 mm max height

SMALL OUTLINE PACKAGE

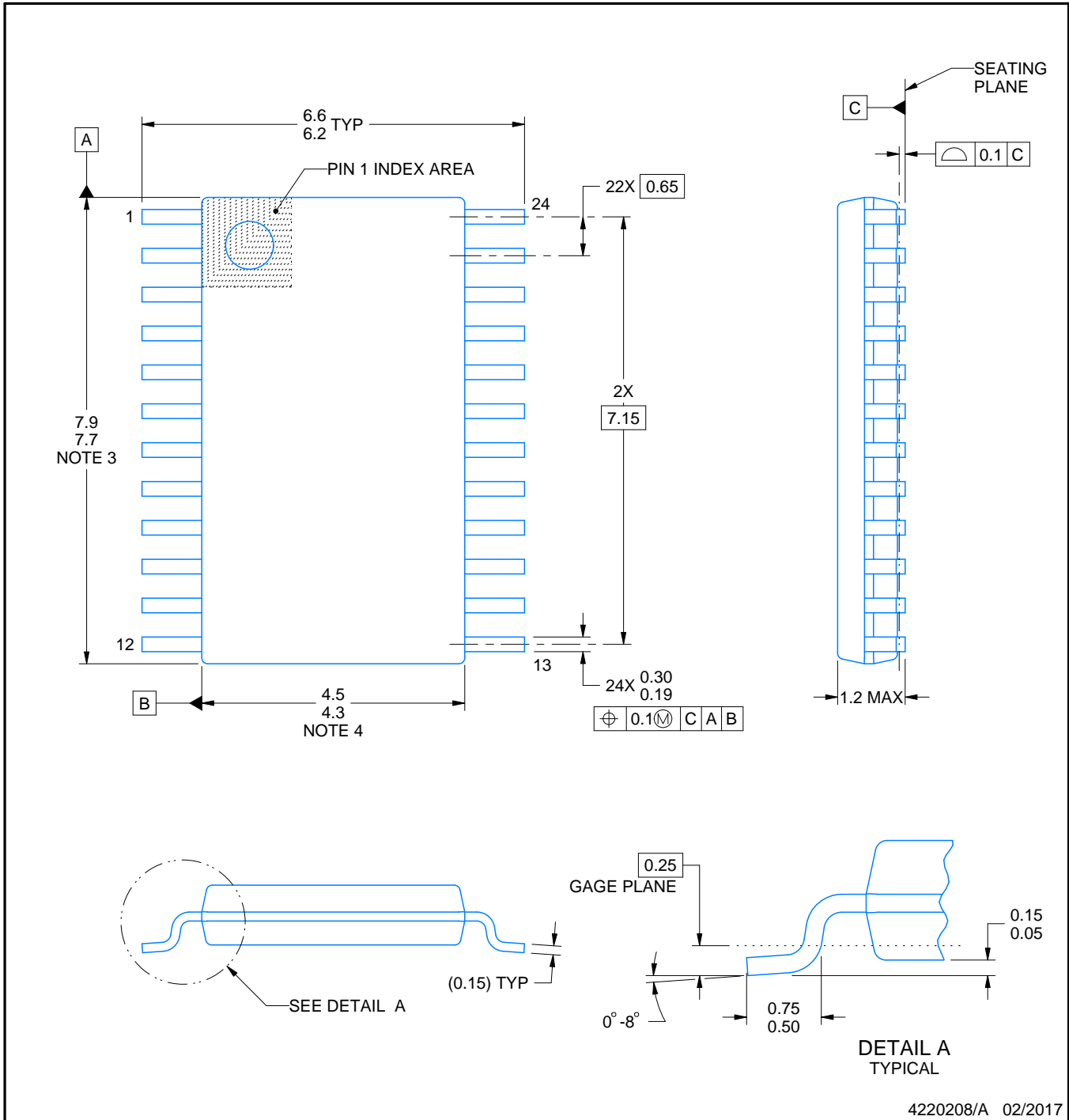

4220208/A 02/2017

NOTES:

1. All linear dimensions are in millimeters. Any dimensions in parenthesis are for reference only. Dimensioning and tolerancing per ASME Y14.5M.
2. This drawing is subject to change without notice.
3. This dimension does not include mold flash, protrusions, or gate burrs. Mold flash, protrusions, or gate burrs shall not exceed 0.15 mm per side.
4. This dimension does not include interlead flash. Interlead flash shall not exceed 0.25 mm per side.
5. Reference JEDEC registration MO-153.

EXAMPLE BOARD LAYOUT

PW0024A

TSSOP - 1.2 mm max height

SMALL OUTLINE PACKAGE

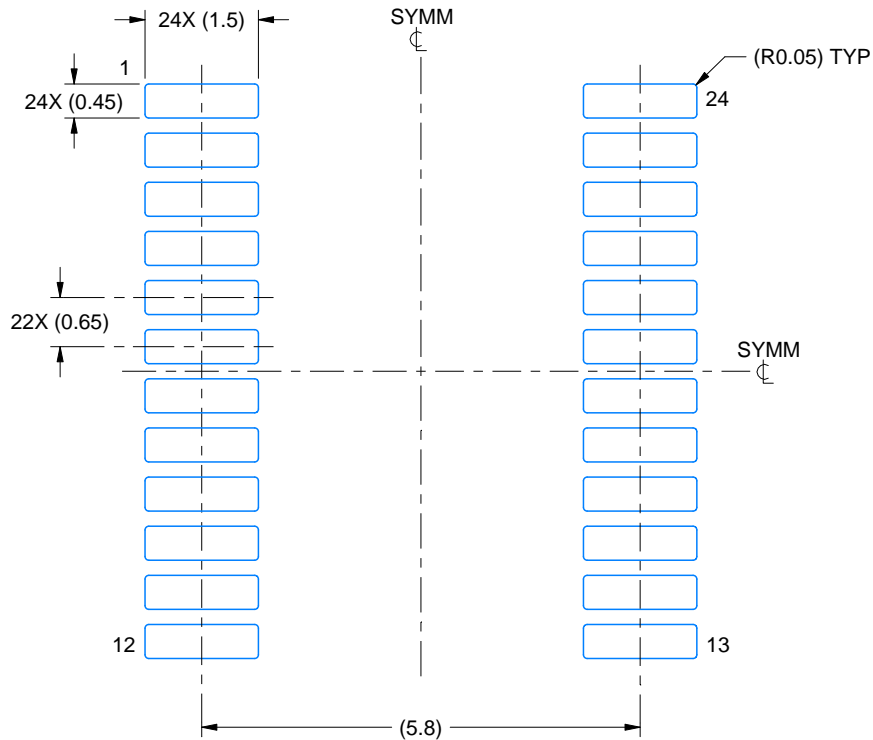

LAND PATTERN EXAMPLE
EXPOSED METAL SHOWN
SCALE: 10X

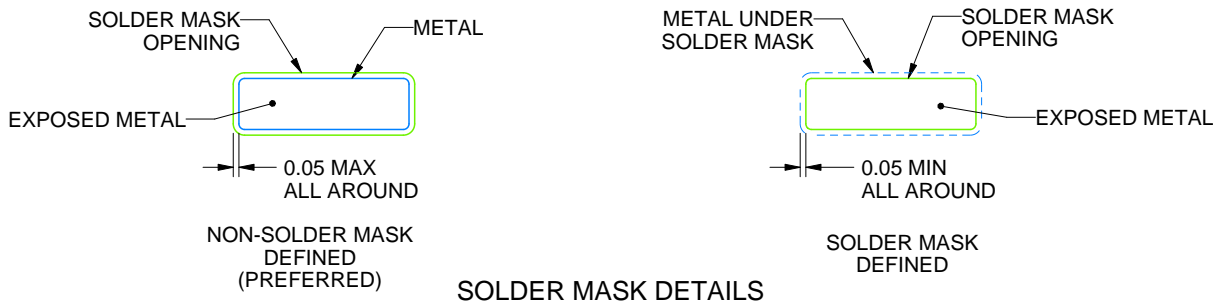

SOLDER MASK DETAILS

4220208/A 02/2017

NOTES: (continued)

- 6. Publication IPC-7351 may have alternate designs.
- 7. Solder mask tolerances between and around signal pads can vary based on board fabrication site.

EXAMPLE STENCIL DESIGN

PW0024A

TSSOP - 1.2 mm max height

SMALL OUTLINE PACKAGE

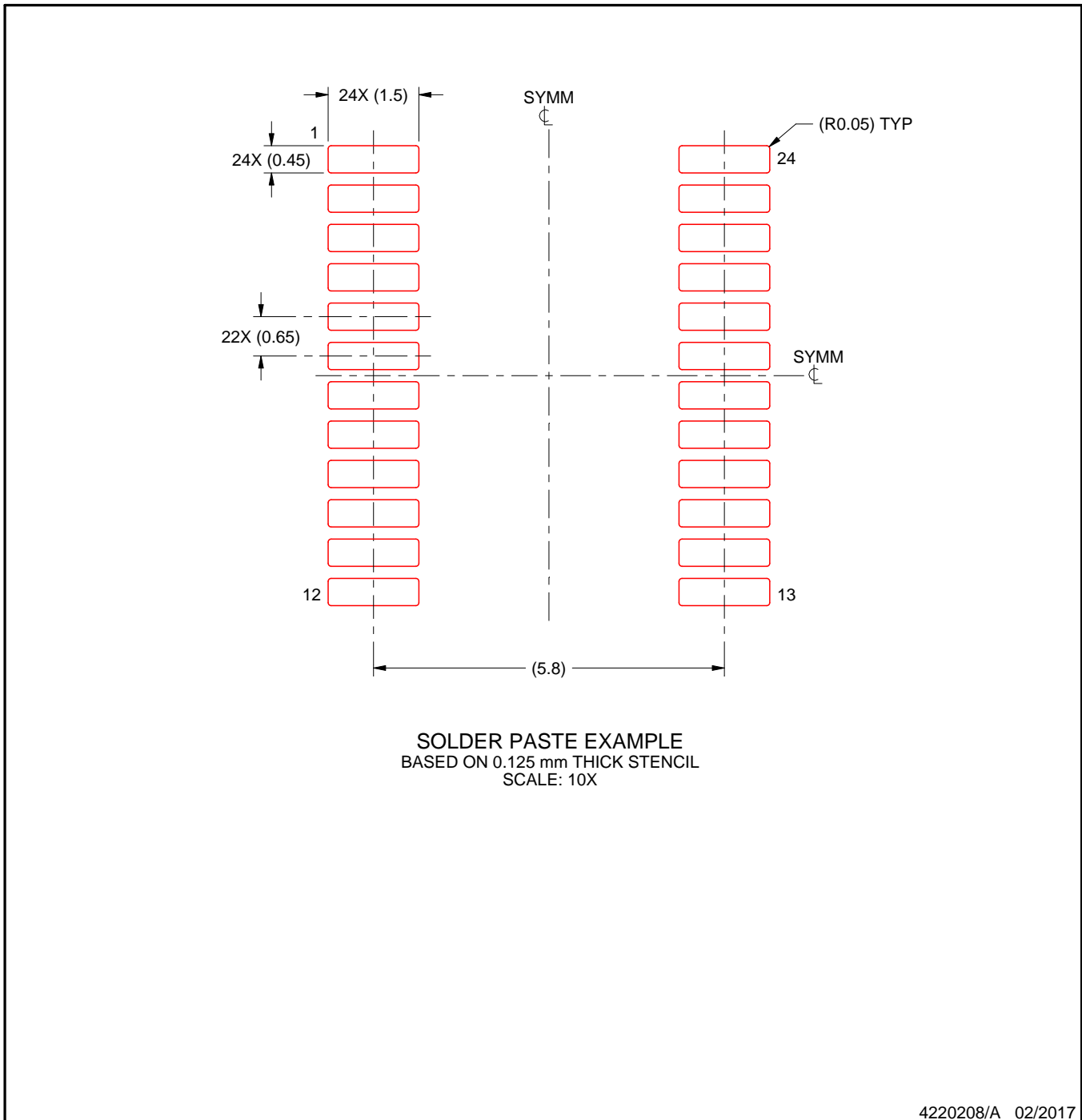

NOTES: (continued)

8. Laser cutting apertures with trapezoidal walls and rounded corners may offer better paste release. IPC-7525 may have alternate design recommendations.
9. Board assembly site may have different recommendations for stencil design.

IMPORTANT NOTICE AND DISCLAIMER

TI PROVIDES TECHNICAL AND RELIABILITY DATA (INCLUDING DATASHEETS), DESIGN RESOURCES (INCLUDING REFERENCE DESIGNS), APPLICATION OR OTHER DESIGN ADVICE, WEB TOOLS, SAFETY INFORMATION, AND OTHER RESOURCES "AS IS" AND WITH ALL FAULTS, AND DISCLAIMS ALL WARRANTIES, EXPRESS AND IMPLIED, INCLUDING WITHOUT LIMITATION ANY IMPLIED WARRANTIES OF MERCHANTABILITY, FITNESS FOR A PARTICULAR PURPOSE OR NON-INFRINGEMENT OF THIRD PARTY INTELLECTUAL PROPERTY RIGHTS.

These resources are intended for skilled developers designing with TI products. You are solely responsible for (1) selecting the appropriate TI products for your application, (2) designing, validating and testing your application, and (3) ensuring your application meets applicable standards, and any other safety, security, regulatory or other requirements.

These resources are subject to change without notice. TI grants you permission to use these resources only for development of an application that uses the TI products described in the resource. Other reproduction and display of these resources is prohibited. No license is granted to any other TI intellectual property right or to any third party intellectual property right. TI disclaims responsibility for, and you fully indemnify TI and its representatives against any claims, damages, costs, losses, and liabilities arising out of your use of these resources.

TI's products are provided subject to [TI's Terms of Sale](#), [TI's General Quality Guidelines](#), or other applicable terms available either on [ti.com](#) or provided in conjunction with such TI products. TI's provision of these resources does not expand or otherwise alter TI's applicable warranties or warranty disclaimers for TI products. Unless TI explicitly designates a product as custom or customer-specified, TI products are standard, catalog, general purpose devices.

TI objects to and rejects any additional or different terms you may propose.

Copyright © 2025, Texas Instruments Incorporated

Last updated 10/2025

Looking for pricing, stock, or lifecycle information?

Click below to explore more details on WIN SOURCE:

 [View BQ7791514PWR on WIN SOURCE](#)

 [Texas Instruments](#) Information

Optimize Your Supply Chain with WIN SOURCE Solutions

-  Global Sourcing Solution
-  Obsolete Management
-  Cost Control Management
-  Shortage Management
-  Alternative Solution
-  Excess Inventory Management