

LTC3207/LTC3207-1
600mA Universal Multi-
Output LED/CAM Driver**DESCRIPTION****WARNING!****Do not look directly at operating LED.**

This circuit produces light that can damage eyes.

Demonstration circuit 1039 is a 600mA Universal Multi-Output LED/CAM Driver with six white LEDs, two RGB LEDs, and a camera flash featuring the LTC3207/LTC3207-1.

The LTC3207/LTC3207-1 is a low noise charge pump designed to drive 12 universal LED (ULED) current sources and one high current camera flash. The LTC3207/LTC3207-1 requires only five small ceramic capacitors to form a complete LED power supply and current controller.

The maximum display currents are set with an internal precision current reference. On/Off blinking, gradation,

and intensity are achieved via an I²C serial interface. See the LTC3207/LTC3207-1 data sheet for more information on this process. There are 64 dimming states available for the universal LEDs and 16 dimming states for the camera LED.

The charge pump optimizes efficiency based on the voltage across the LED current sources. The part powers up in 1x mode and will automatically switch to boost mode whenever any enabled LED current source begins to drop out. The first dropout switches the part to 1.5x mode and a subsequent dropout switches the part into 2x mode. The part resets to 1x mode whenever a data byte is updated via the I²C port.

Design files for this circuit board are available. Call the LTC factory.

 LTC, LTM, LT are registered trademarks of Linear Technology Corporation. Other product names may be trademarks of the companies that manufacture the products.

QUICK START PROCEDURE

Demonstration circuit 1039 is easy to set up to evaluate the performance of the LTC3207/LTC3207-1. Refer to Figure 1 for proper measurement equipment setup and follow the procedure below:

NOTE. When measuring the input or output voltage ripple, care must be taken to avoid a long ground lead on the oscilloscope probe. Measure the input or output voltage ripple by touching the probe tip directly across the VBAT and GND terminals. See Figure 2 for proper scope probe technique.

1. Refer to the DC590 Quick Start Guide for QuikEval™ setup and software installation details.
2. Make sure the USB cable is connected between the computer and the DC590 controller board.

NOTE. If using the DC590B board, a specific DVCC voltage level may be selected. This is done by setting the VCCIO jumper on the DC590 board to one of the following settings: 3.3V, 5V, removed for 2.7V or set to external if use of an external supply is desired.

3. Connect DC1039 to the DC590 USB Serial Controller using the supplied 14-conductor ribbon cable as shown in Figure 1.
4. With power off, connect the input power supply to VBAT and GND with a series ammeter and a voltmeter as shown in Figure 1.
5. Turn on and set the input power supply between 2.9 – 5.5V. The DC1039 has an extra 4.7uF de-coupling capacitor between VBAT and GND to help accommodate long VBAT source lead lengths. The DC590 board gets its power from the USB cable.

NOTE. Make sure that the input voltage does not exceed 6V.

6. Run the QuikEval program. The program detects the DC1039 and displays the LTC3207 control window (shown in Figure 3).

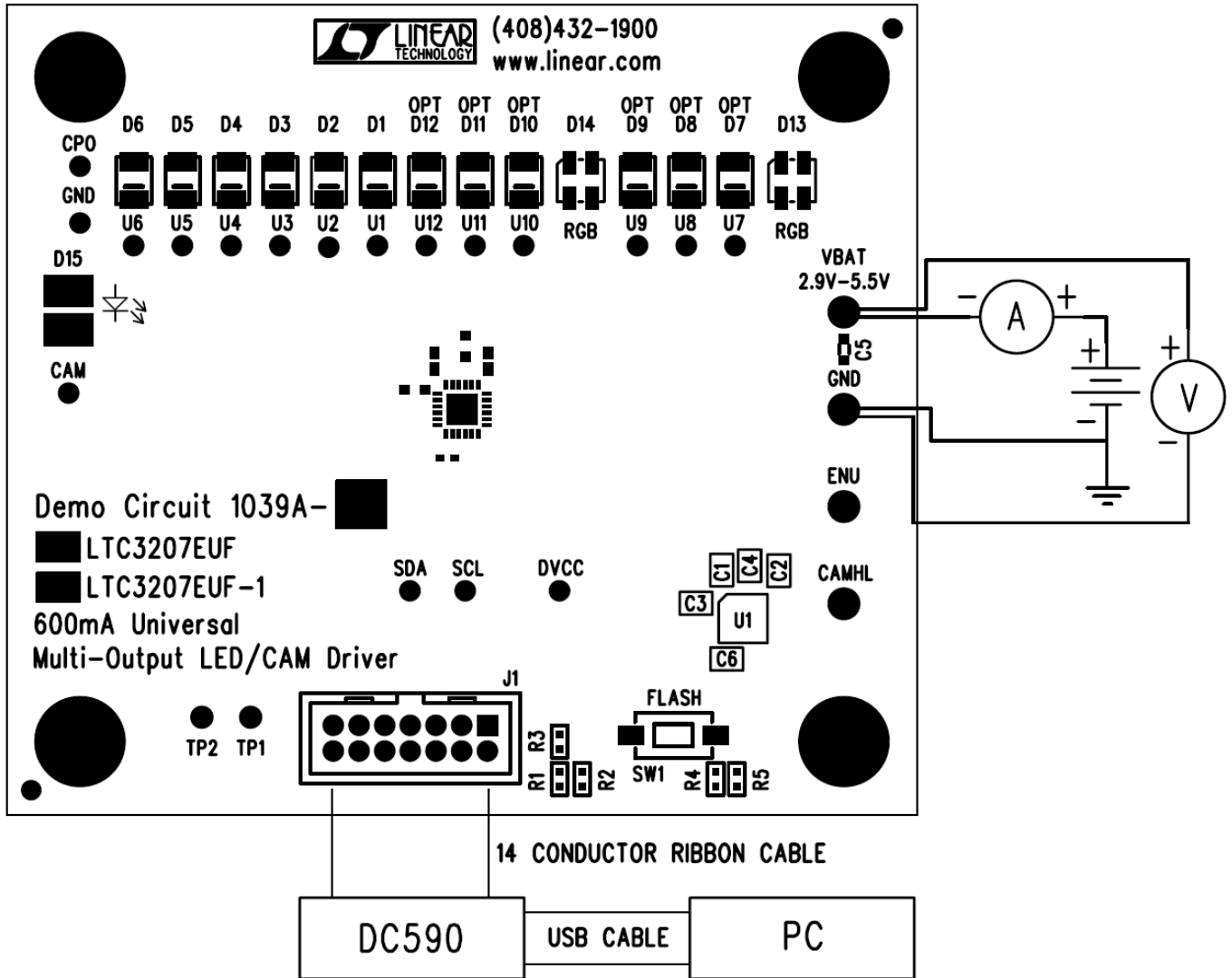

Figure 1. Proper Measurement Equipment Setup

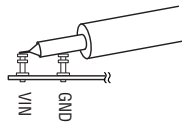

Figure 2. Measuring Input or Output Ripple

USING THE LTC3207 QUIKEVAL SOFTWARE

The LTC3207 program provides brightness controls for the universal and camera LEDs. It also allows the user to gradate the universal LEDs up or down and blink at a selected on-time and period. The LTC3207/LTC3207-1 also controls the LEDs from an external enable pin, and may flash the camera LED using the I²C port or an external switch. The intensity of the universal LEDs may be set by 1) Selecting the desired ULED select button. 2) Setting the intensity in the associated vertical slider. 3) Selecting the SET ULEDs button.

LTC3207/LTC3207-1 select button selects between the LTC3207 and the LTC3207-1 I²C address to drive demo boards with either the LTC3207 or the LTC3207-1.

VIEW LTC3207 PRODUCT PAGE button opens an internet browser and searches the Linear Technology Corporation web site for information on the LTC3207 when an internet connection is available.

REG 0 through **REG 15** text box windows display the hexadecimal value that has been written to the corresponding registers.

SELECT ALL selects all universal LEDs to change when the SET ULEDs, CLEAR ULEDs, or other ULED control buttons are selected.

DESELECT ALL deselects all selected universal LEDs and prevents the universal LEDs from changing intensity or modes.

ULED1 through **ULED12** select buttons are used to individually select or deselect the universal LEDs.

ULED (1/4) vertical slide control adjusts the intensity for selected universal LEDs U1 and U4 from 0 to 27.5mA in 64 steps. The SET ULEDs, BLINK ULEDs, or other LED control buttons need to be selected to illuminate the selected LEDs. The LED intensity slider may be adjusted by clicking on the up or down arrows to increment by one LSB or by clicking and dragging the slide pointer. The hex code is displayed in the box below the slider.

ULED (2/5) vertical slide control adjusts the intensity for selected universal LEDs U2 and U5 from 0 to 27.5mA in 64 steps. The SET ULEDs, BLINK ULEDs, or other LED control buttons need to be selected to illuminate the se-

lected LEDs. The LED intensity slider may be adjusted by clicking on the up or down arrows to increment by one LSB or by clicking and dragging the slide pointer. The hex code is displayed in the box below the slider.

ULED (3/6) vertical slide control adjusts the intensity for selected universal LEDs U3 and U6 from 0 to 27.5mA in 64 steps. The SET ULEDs, BLINK ULEDs, or other LED control buttons need to be selected to illuminate the selected LEDs. The LED intensity slider may be adjusted by clicking on the up or down arrows to increment by one LSB or by clicking and dragging the slide pointer. The hex code is displayed in the box below the slider.

RED (7/10) vertical slide control adjusts the intensity for selected universal LEDs U7 and U10 from 0 to 27.5mA in 64 steps. The SET ULEDs, BLINK ULEDs, or other LED control buttons need to be selected to illuminate the selected LEDs. The LED intensity slider may be adjusted by clicking on the up or down arrows to increment by one LSB or by clicking and dragging the slide pointer. The hex code is displayed in the box below the slider.

GREEN (8/11) vertical slide control adjusts the intensity for selected universal LEDs U8 and U11 from 0 to 27.5mA in 64 steps. The SET ULEDs, BLINK ULEDs, or other LED control buttons need to be selected to illuminate the selected LEDs. The LED intensity slider may be adjusted by clicking on the up or down arrows to increment by one LSB or by clicking and dragging the slide pointer. The hex code is displayed in the box below the slider.

BLUE (9/12) vertical slide control adjusts the intensity for selected universal LEDs U9 and U12 from 0 to 27.5mA in 64 steps. The SET ULEDs, BLINK ULEDs, or other LED control buttons need to be selected to illuminate the selected LEDs. The LED intensity slider may be adjusted by clicking on the up or down arrows to increment by one LSB or by clicking and dragging the slide pointer. The hex code is displayed in the box below the slider.

SET ULEDs button sets all selected LEDs to the selected intensity settings.

QUICK WRITE button sets all LEDs to the intensity and mode of ULED1 using the LTC3207/LTC3207-1 Quick

Write feature. The intensity of ULED1 is updated to the value indicated on the ULED (1/4) vertical slider. All vertical sliders and register text boxes on the LTC3207 Control Window are updated to match the IC settings. The ULED1 select button does not need to be selected for this button to work.

CLEAR ULEDs button turns off and clears the register for all selected LEDs.

ENU OUTPUT SELECT button sets or unsets the ENU control for the selected LEDs. When an LED ENU output is selected, the ULED register label below the ULED register text box is highlighted in blue. If gradation with ENU control is desired, use the START GRADATION WITH ENU control button.

SET ENU PIN HI/LO button sets the ENU pin high or low and turns on or off the LEDs under ENU control. If the LED is set for gradation or blinking with ENU control, the LED will gradate up/down, or start/stop blinking at the selected intensity.

GRADATION TIME option buttons set the desired time to gradate up to or down from the selected LED intensity when the GRADATE UP, GRADATE DOWN, START GRADATION WITH ENU or Demo 1 button is selected. If the DISABLED option button is selected, the universal LEDs will not gradate when any of the GRADATION control buttons are selected.

GRADATE UP button gradates the selected LEDs up to the desired intensity and disables gradation when done. The ULED select button is highlighted purple to indicate that gradation mode has been enabled.

GRADATE DOWN button gradates the selected LEDs down from the set intensity and disables gradation when done. The ULED select button is highlighted purple to indicate that gradation mode has been enabled.

START GRADATION WITH ENU button gradates the selected LEDs up to the set intensity when the ENU pin is high (SET ENU PIN HI button is selected) and down when the ENU pin is low. Note: the gradation time must be set to something other than DISABLED to gradate the LEDs. Selecting this button when GRADATION WITH ENU is enabled and the ENU PIN is high, gradation and ENU control will be disabled with the LEDs set. Selecting this button when GRADATION WITH ENU is enabled and

the ENU PIN is low, gradation and ENU control will be disabled with the LEDs off. During gradation with ENU control, all other ULEDs and the flash LED must remain off and the charge pump must remain in Auto mode (not forced to any mode). The ULED select button is highlighted purple to indicate that gradation mode has been enabled.

BLINK ONt/PERIOD option buttons set the desired blinking on-time and period to blink after the BLINK ULEDs button has been selected.

BLINK ULEDs button blinks or stops blinking the selected LEDs at the on-time and period selected by the BLINK ONt/PERIOD option buttons and at the selected LED intensity. The ULED select button is highlighted green to indicate that blink mode has been enabled.

CHARGE PUMP MODE option buttons allow the user to select between Auto switching (not forced to any mode), Force 1x, Force 1.5x, and Force 2x charge pump modes.

GPO MODE button disables or enables dropout for the selected LEDs. When dropout is disabled the LED will not cause the charge pump to switch into 1.5x or 2x modes and the pin may be used as a general-purpose output (GPO). The ULED select button is highlighted orange to indicate that GPO MODE has been selected.

UPDATE ALL REG button updates the data registers to the data displayed in the register text boxes.

LEDs OFF button turns off and resets all LEDs and LED modes, plus stops and resets all demos.

CAML intensity vertical slide control adjusts the CAM display from 0 to 170mA in 7 steps. The current is limited in software because some LEDs can not handle large continuous currents for long periods. The LED intensity may be adjusted by clicking on the up or down arrows to increment by one LSB or by clicking and dragging the slide pointer. The hex code is displayed in the box below the slider.

CAMH intensity vertical slide control sets the CAMH register from 0 to 425mA in 16 steps. When the CAM FLASH button is selected, the CAM LED illuminates at the intensity set by the CAMH register on the release of the mouse button for the length of time selected in the FLASH Time drop-down window up to two seconds. The

LED intensity may be adjusted by clicking on the up or down arrows to increment by one LSB or by clicking and dragging the slide pointer. The hex code is displayed in the box below the slider.

FLASH Time drop-down window allows the user to select a flash time from 50ms to 5000ms in various increments. The flash time is the time the program selects the CAMH register and starts on the release of the mouse button after the CAM FLASH button was selected.

CAM FLASH button will flash the CAM LED at the intensity selected in the CAMH register after the CAM FLASH button has been released. The flash will last for the period selected in the FLASH Time drop-down window or until the LTC3207's two second safety timer has elapsed. This is accomplished by setting the CAMHL bit in register 0. Once the CAM flash begins, the program will not flash the CAM LED again until double the selected flash time has elapsed to prevent any damage to the LED.

FLASH push button is located next to J1 on the DC1039 demo board. This button sets the CAMHL pin while depressed and will flash the CAM LED at the intensity selected in the CAMH register up to two seconds or until the FLASH button is released.

DEMO 1-Rainbow button may be selected to start or stop Demo 1. Demo 1 cycles through the different colors that the two RGB LEDs can produce using the LTC3207/LTC3207-1's gradation feature. The default gradation time for this demo is 0.96s, however the 0.48s or 0.24s gradation times may be used by selecting the desired gradation time prior to starting the demo.

DEMO 2-Light Cycle button gradates up and blinks all universal LEDs starting with ULED1 to ULED12. After all LEDs are up and blinking, the LEDs are gradated off starting with ULED1 to ULED12. This is accomplished using the LTC3207/LTC3207-1's gradation and blinking modes.

LTC3207/LTC3207-1

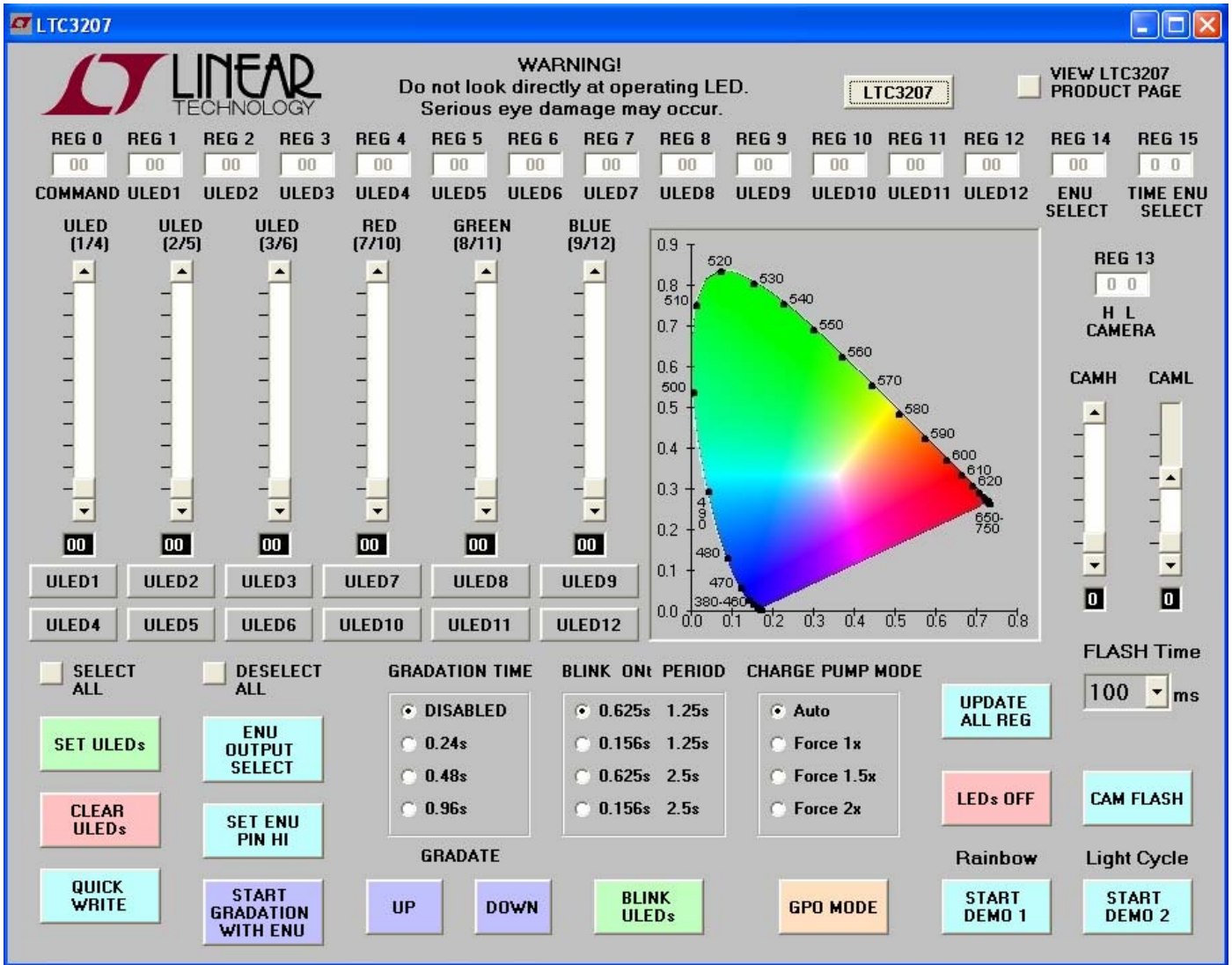
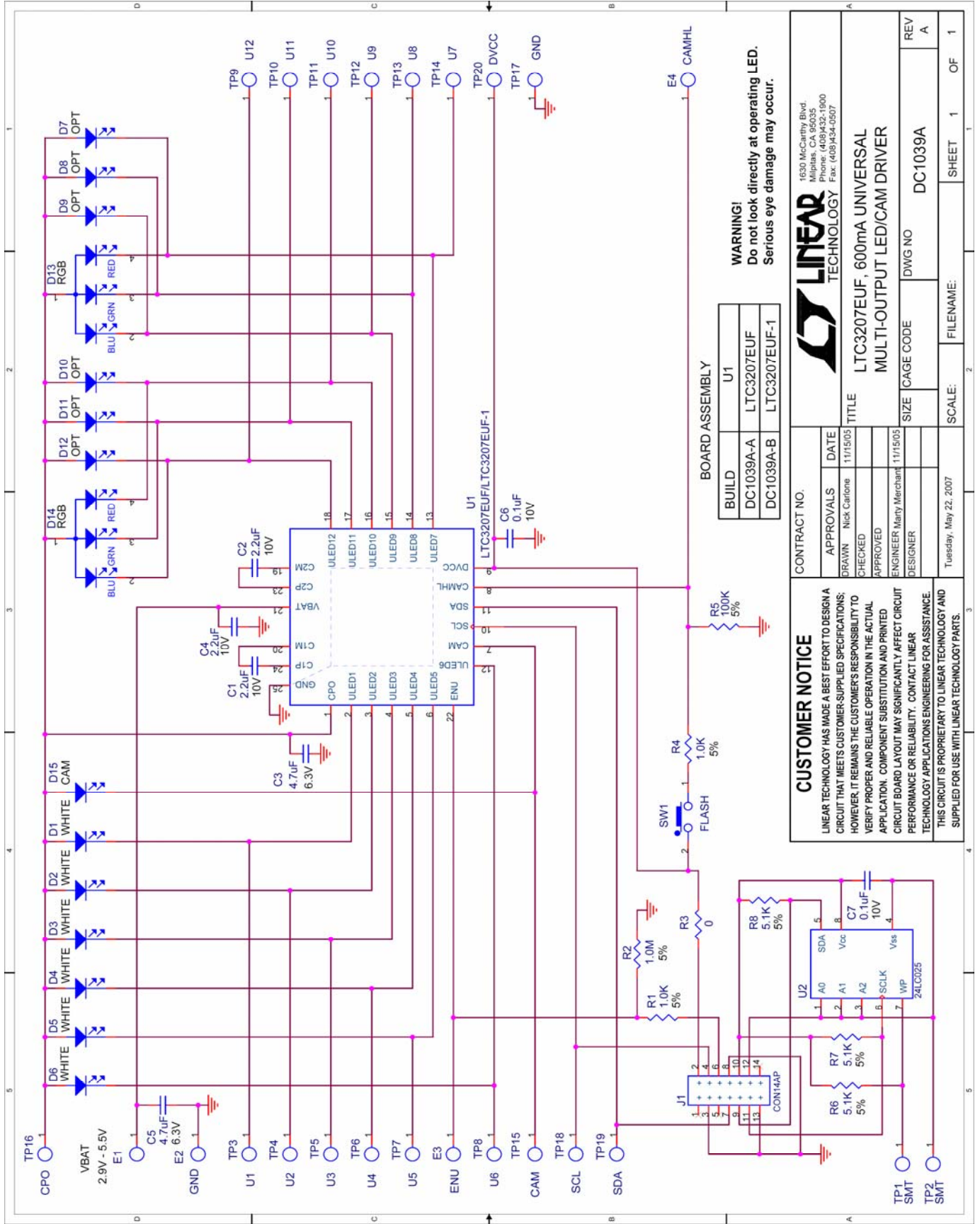

Figure 3. LTC3207 Control Window



WARNING!
Do not look directly at operating LED.
Serious eye damage may occur.

BOARD ASSEMBLY	
BUILD	U1
DC1039A-A	LTC3207EUF
DC1039A-B	LTC3207EUF-1

		1630 McCarthy Blvd. Milpitas, CA 95035 Phone: (408)432-1900 Fax: (408)434-0507	
CUSTOMER NOTICE LINEAR TECHNOLOGY HAS MADE A BEST EFFORT TO DESIGN A CIRCUIT THAT MEETS CUSTOMER-SUPPLIED SPECIFICATIONS; HOWEVER, IT REMAINS THE CUSTOMER'S RESPONSIBILITY TO VERIFY PROPER AND RELIABLE OPERATION IN THE ACTUAL APPLICATION. COMPONENT SUBSTITUTION AND PRINTED CIRCUIT BOARD LAYOUT MAY SIGNIFICANTLY AFFECT CIRCUIT PERFORMANCE OR RELIABILITY. CONTACT LINEAR TECHNOLOGY APPLICATIONS ENGINEERING FOR ASSISTANCE. THIS CIRCUIT IS PROPRIETARY TO LINEAR TECHNOLOGY AND SUPPLIED FOR USE WITH LINEAR TECHNOLOGY PARTS.		CONTRACT NO. APPROVALS DRAWN Nick Carlone 11/15/05 CHECKED APPROVED ENGINEER Mary Merchant 11/15/05 DESIGNER	
TITLE LTC3207EUF, 600mA UNIVERSAL MULTI-OUTPUT LED/CAM DRIVER		SIZE CAGE CODE DC1039A	
FILENAME: Tuesday, May 22, 2007		SCALE: 1 OF 1	

LTC3207/LTC3207-1

Linear Technology Corporation
LTC3207EUF

Parts List

Demo Circuit 1039A-A Rev A
6/15/2007

Item	Qty	Ref - Des	Desc	Manufacturer's Part Number
REQUIRED CIRCUIT COMPONENTS:				
1	3	C1, C2, C4	CAP, X5R 2.2uF 10V 10% 0603	MURATA, GRM188R61A225KE34D
2	1	C3	CAP, X5R 4.7uF 6.3V 10% 0603	TDK, C1608X5R0J475K
3	1	C6	CAP, X5R 0.1uF 10V 10% 0402	MURATA, GRM155R61A104KA01
4	6	D1-D6	LED, SMT WHITE	NICHIA, NSSW100BT
5	2	D13,D14	LED, SMT RGB	NICHIA, NSCM315C
6	1	D15	LED, SMT FLASH	AOT, AOT-2015HPW-1751B
7	1	U1	IC, 600mA UNIVERSAL LED/CAM DRIVER	LINEAR TECH., LTC3207EUF
ADDITIONAL DEMO BOARD CIRCUIT COMPONENTS:				
1	1	C5	CAP, X5R 4.7uF 6.3V 10% 0603	TDK, C1608X5R0J475K
2	1	C7	CAP, X5R 0.1uF 10V 10% 0402	MURATA, GRM155R61A104KA01
3	2	R1,R4	RES, 1.0K OHMS 5% 1/16W 0402	VISHAY, CRCW04021K00JNED
4	1	R2	RES, 1.0M OHMS 5% 1/16W 0402	VISHAY, CRCW04021M00JNED
5	1	R5	RES, 100K OHMS 5% 1/16W 0402	VISHAY, CRCW0402100KJNED
6	1	R3	RES, 0 OHMS 1/16W 0402	VISHAY, CRCW0402000Z0ED
7	3	R6,R7,R8	RES, 5.1K OHMS 5% 1/16W 0402	VISHAY, CRCW04025K10JNED
8	0	D7-D12 (OPT)	LED, SMT WHITE	NICHIA, NSSW100BT
9	1	SW1	SWITCH, PUSH BUTTON	PANASONIC, EVQPPFA25
10	1	U2	IC, SERIAL EEPROM	MICROCHIP, 24LC025-I/ST
HARDWARE FOR DEMO BOARD ONLY:				
1	1	J1	HEADER, 2X7 2MM STRAIGHT	MOLEX/WALDOM, 87831-1420
2	4	E1-E4	TURRET, TESTPOINT	MILL-MAX, 2308-02
3	4		STANDOFFS	KEYSTONE, 8831
4	1		CABLE ASSY., 8" STRIP	LINEAR RIBBON CABLE, CA-2440

Linear Technology Corporation
LTC3207EUF-1

Parts List

Demo Circuit 1039A-B Rev A
6/15/2007

Item	Qty	Ref - Des	Desc	Manufacturer's Part Number
REQUIRED CIRCUIT COMPONENTS:				
1	3	C1, C2, C4	CAP, X5R 2.2uF 10V 10% 0603	MURATA, GRM188R61A225KE34D
2	1	C3	CAP, X5R 4.7uF 6.3V 10% 0603	TDK, C1608X5R0J475K
3	1	C6	CAP, X5R 0.1uF 10V 10% 0402	MURATA, GRM155R61A104KA01
4	6	D1-D6	LED, SMT WHITE	NICHIA, NSSW100BT
5	2	D13,D14	LED, SMT RGB	NICHIA, NSCM315C
6	1	D15	LED, SMT FLASH	AOT, AOT-2015HPW-1751B
7	1	U1	IC, 600mA UNIVERSAL LED/CAM DRIVER	LINEAR TECH., LTC3207EUF-1
ADDITIONAL DEMO BOARD CIRCUIT COMPONENTS:				
1	1	C5	CAP, X5R 4.7uF 6.3V 10% 0603	TDK, C1608X5R0J475K
2	1	C7	CAP, X5R 0.1uF 10V 10% 0402	MURATA, GRM155R61A104KA01
3	2	R1,R4	RES, 1.0K OHMS 5% 1/16W 0402	VISHAY, CRCW04021K00JNED
4	1	R2	RES, 1.0M OHMS 5% 1/16W 0402	VISHAY, CRCW04021M00JNED
5	1	R5	RES, 100K OHMS 5% 1/16W 0402	VISHAY, CRCW0402100KJNED
6	1	R3	RES, 0 OHMS 1/16W 0402	VISHAY, CRCW0402000Z0ED
7	3	R6,R7,R8	RES, 5.1K OHMS 5% 1/16W 0402	VISHAY, CRCW04025K10JNED
8	0	D7-D12 (OPT)	LED, SMT WHITE	NICHIA, NSSW100BT
9	1	SW1	SWITCH, PUSH BUTTON	PANASONIC, EVQPPFA25
10	1	U2	IC, SERIAL EEPROM	MICROCHIP, 24LC025-I/ST
HARDWARE FOR DEMO BOARD ONLY:				
1	1	J1	HEADER, 2X7 2MM STRAIGHT	MOLEX/WALDOM, 87831-1420
2	4	E1-E4	TURRET, TESTPOINT	MILL-MAX, 2308-02
3	4		STANDOFFS	KEYSTONE, 8831
4	1		CABLE ASSY., 8" STRIP	LINEAR RIBBON CABLE, CA-2440

Looking for pricing, stock, or lifecycle information?

Click below to explore more details on WIN SOURCE:

 [View DC1039A-B on WIN SOURCE](#)

 [Analog Devices Inc. Information](#)

Optimize Your Supply Chain with WIN SOURCE Solutions

-  Global Sourcing Solution
-  Obsolete Management
-  Cost Control Management
-  Shortage Management
-  Alternative Solution
-  Excess Inventory Management