



**THE DATASHEET OF
XS618B1PBM12**



GENERAL DESCRIPTION

The ADIS1620x/PCBs are simple evaluation boards that provide convenient access to the ADIS1620x family of products, using a standard 2 mm, 2 × 6, connector interface. These connectors can be accessed using a variety of cable options, including standard 1 mm ribbon cables. The ADIS1620x/PCB is designed to be evaluated in an existing digital platform (such as MCU, DSP, FPGA, PLD) or as part of the ADISEVAL system. Four mounting holes (sized for 2-56 or 2 mm screws) have been provided to secure the board during evaluation.

CIRCUIT DESCRIPTION

The schematic, layout, and parts list for the ADIS1620x/PCB can be found in

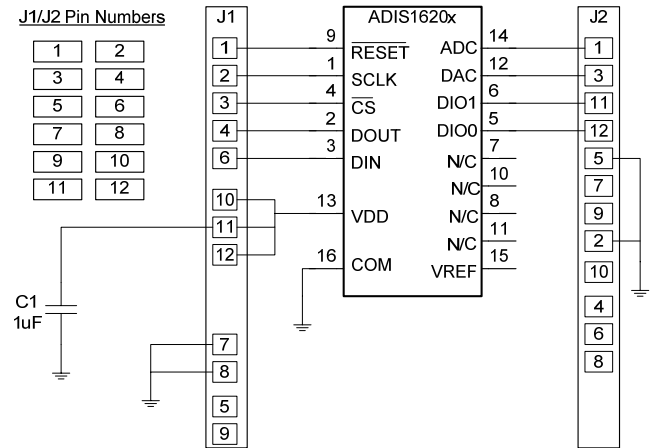

Figure 1,

Figure 1. ADIS1620x/PCB Schematic

Figure 2, and Table 1.

The ADIS1620x's digitized outputs can be accessed using the 4-wire serial port interface (SPI) signals on J1: SCLK, CS, DOUT, and DIN. For specific information on using the ADIS1620x SPI interface, refer to the [ADIS16201](#) data sheet. Auxiliary functions, such as the 12-bit ADC input, can be accessed using J2. C1 provides additional power supply filtering but is generally not required.

Table 1. Parts List

Reference Designator	Part Description
U1	ADIS1620xyCCZ ¹
J1, J2	12-pin, dual row, 2 mm connector
C1	Power supply filtering, not installed

¹ x = 0, 1, 2, 3, 4 or 9, y = B or C

SPECIAL NOTES ON HANDLING

Note that the ADIS1620x/PCB is not reverse-polarity protected. Reversing the power supply or applying inappropriate voltages (that is, voltages outside the Absolute Maximum Ratings in the ADIS1620x data sheets) to any pin may damage the ADIS1620x/PCB.

Table 2. Power Supply Levels

Parameter	Range
V _{CC}	3.0V to 3.6V

Rev. PrA

Evaluation boards are only intended for device evaluation and not for production purposes. Evaluation boards as supplied "as is" and without warranties of any kind, express, implied, or statutory including, but not limited to, any implied warranty of merchantability or fitness for a particular purpose. No license is granted by implication or otherwise under any patents or other intellectual property by application or use of evaluation boards. Information furnished by Analog Devices is believed to be accurate and reliable. However, no responsibility is assumed by Analog Devices for its use, nor for any infringements of patents or other rights of third parties that may result from its use. Analog Devices reserves the right to change devices or specifications at any time without notice. Trademarks and registered trademarks are the property of their respective owners. Evaluation boards are not authorized to be used in life support devices or systems.

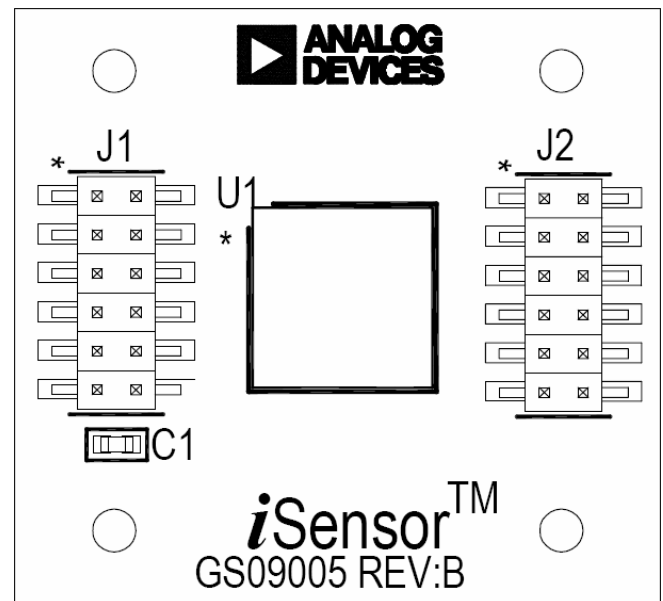

Figure 2. ADIS1620x/PCB Layout (Top View)

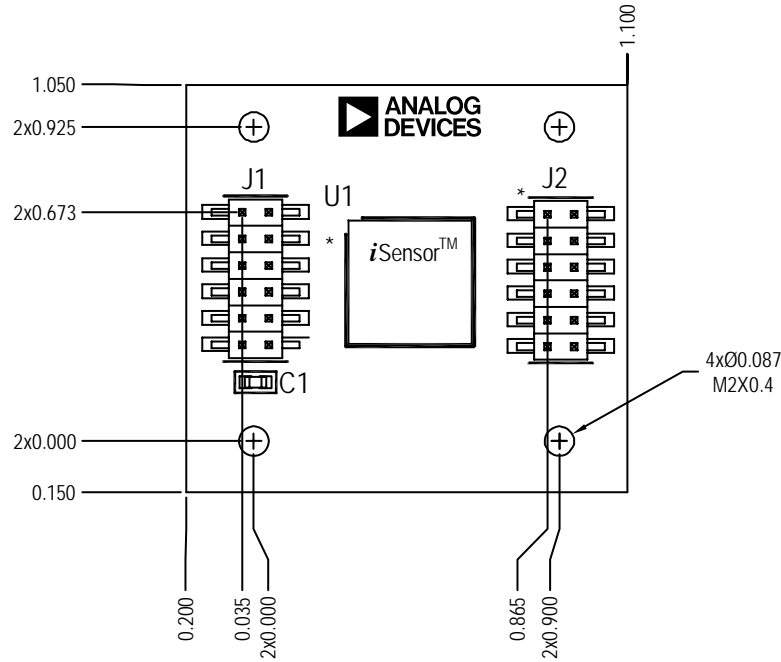

Figure 3. ADIS1620x/PCB Mechanical Drawing

ORDERING GUIDE

Model	Description
ADIS16201/PCBZ	Evaluation Board
ADIS16202/PCBZ	Evaluation Board
ADIS16203/PCBZ	Evaluation Board
ADIS16204/PCBZ	Evaluation Board
ADIS16209/PCBZ	Evaluation Board

¹ Z = RoHS Compliant Part.

ESD CAUTION



ESD (electrostatic discharge) sensitive device. Charged devices and circuit boards can discharge without detection. Although this product features patented or proprietary protection circuitry, damage may occur on devices subjected to high energy ESD. Therefore, proper ESD precautions should be taken to avoid performance degradation or loss of functionality.

Looking for pricing, stock, or lifecycle information?

Click below to explore more details on WIN SOURCE:

 [View XS618B1PBM12 on WIN SOURCE](#)

 [Manufacturer Information](#)

Optimize Your Supply Chain with WIN SOURCE Solutions

-  Global Sourcing Solution
-  Obsolete Management
-  Cost Control Management
-  Shortage Management
-  Alternative Solution
-  Excess Inventory Management