

nRF9160

Product Specification

v2.2

nRF9160 features

Features:

Microcontroller:

- Arm[®] Cortex[®]-M33
 - 247 EEMBC CoreMark[®] score running from flash memory
 - Data watchpoint and trace (DWT), embedded trace macrocell (ETM), and instrumentation trace macrocell (ITM)
 - Serial wire debug (SWD)
 - Trace port
- 1 MB flash
- 256 kB low leakage RAM
- Arm TrustZone[®]
- Arm CryptoCell[™] 310
- Up to 4x SPI master/slave with EasyDMA
- Up to 4x I2C compatible two-wire master/slave with EasyDMA
- Up to 4x UART (CTS/RTS) with EasyDMA
- I2S with EasyDMA
- Digital microphone interface (PDM) with EasyDMA
- 4x pulse width modulator (PWM) unit with EasyDMA
- 12-bit, 200 ksp/s ADC with EasyDMA - eight configurable channels with programmable gain
- 3x 32-bit timer with counter mode
- 2x real-time counter (RTC)
- Programmable peripheral interconnect (PPI)
- 32 general purpose I/O pins
- Single supply voltage: 3.0 – 5.5 V
- All necessary clock sources integrated
- Package: 10.5 × 16 × 1.04 mm LGA

LTE modem:

- Transceiver and baseband
 - 3GPP LTE release 13 Cat-M1 and Cat-NB1 compliant
 - 3GPP release 13 coverage enhancement
 - 3GPP LTE release 14 Cat-NB2 compliant
 - GPS receiver
 - GPS L1 C/A supported
 - QZSS L1 C/A supported
 - RF transceiver for global coverage
 - Up to 23 dBm output power
 - -108 dBm sensitivity (LTE-M) for low band, -107 dBm for mid band
 - Single 50 Ω antenna interface
 - LTE band support in hardware:
 - Cat-M1: B1, B2, B3, B4, B5, B8, B12, B13, B18, B19, B20, B25, B26, B28, B66
 - Cat-NB1/NB2: B1, B2, B3, B4, B5, B8, B12, B13, B17, B19, B20, B25, B26, B28, B66
 - Supports SIM and eSIM with an ETSI TS 102 221 compatible UICC interface
 - Power saving features: DRX, eDRX, PSM
 - IP v4/v6 stack
 - Secure socket (TLS/DTLS) API
- Current consumption @ 3.7 V:**
- Power saving mode (PSM) floor current: 2.7 μA
 - eDRX @ 81.92s: 18 μA in Cat-M1, 37 μA in Cat-NB1 (UICC included)

Applications:

- Sensor networks
- Logistics and asset tracking
- Smart energy
- Smart building automation
- Smart agriculture
- Industrial
- Retail and monitor devices
- Medical devices
- Wearables

Contents

nRF9160 features	ii
1 Revision history	10
2 About this document	13
2.1 Document status	13
2.2 Peripheral chapters	13
2.2.2 Peripheral instantiation	13
2.3 Register tables	14
2.3.1 Fields and values	14
2.3.2 Permissions	15
2.4 Registers	15
2.4.1 DUMMY	15
3 Product overview	16
3.1 Block diagram	16
3.2 Peripheral interface	17
3.2.1 Peripheral ID	18
3.2.2 Peripherals with shared ID	19
3.2.3 Peripheral registers	19
3.2.4 Bit set and clear	19
3.2.5 Tasks	20
3.2.6 Events	20
3.2.7 Publish and subscribe	20
3.2.8 Shortcuts	20
3.2.9 Interrupts	20
3.2.10 Secure/non-secure peripherals	21
4 Application core	22
4.1 CPU	22
4.1.1 Floating-point interrupt	22
4.1.2 CPU and support module configuration	22
4.1.3 Electrical specification	23
4.2 Memory	23
4.2.1 Memory map	25
4.2.2 Instantiation	27
4.2.3 Peripheral access control capabilities	29
4.3 VMC — Volatile memory controller	30
4.3.1 Registers	30
4.4 NVMC — Non-volatile memory controller	31
4.4.1 Writing to flash	32
4.4.2 Erasing a secure page in flash	32
4.4.3 Erasing a non-secure page in flash	32
4.4.4 Writing to user information configuration registers (UICR)	32
4.4.5 Erase all	33
4.4.6 NVMC protection mechanisms	33
4.4.7 Cache	34
4.4.8 Registers	34
4.4.9 Electrical specification	38

4.5 FICR — Factory information configuration registers.	38
4.5.1 Registers.	38
4.6 UICR — User information configuration registers.	44
4.6.1 Registers.	44
4.7 EasyDMA.	48
4.7.1 EasyDMA error handling.	49
4.7.2 EasyDMA array list.	50
4.8 AHB multilayer interconnect.	50
4.8.1 AHB multilayer priorities.	51
5 Power and clock management.	52
5.1 Power management.	52
5.1.1 System Disabled mode.	52
5.1.2 System OFF mode.	53
5.1.3 System ON mode.	54
5.1.4 Electrical specification.	54
5.2 Power supply.	54
5.2.1 General purpose I/O supply.	54
5.3 Power supply monitoring.	55
5.3.1 Power supply supervisor.	55
5.3.2 External power failure warning.	56
5.3.3 Battery monitoring on VDD.	57
5.3.4 Electrical specification.	57
5.4 Clock management.	58
5.4.1 HFCLK clock controller.	59
5.4.2 LFCLK clock controller.	60
5.4.3 Electrical specification.	60
5.5 Reset.	61
5.5.1 Power-on reset.	61
5.5.2 Pin reset.	61
5.5.3 Wakeup from System OFF mode reset.	61
5.5.4 Soft reset.	62
5.5.5 Watchdog reset.	62
5.5.6 Brownout reset.	62
5.5.7 Retained registers.	62
5.5.8 Reset behavior.	62
5.5.9 Electrical specification.	63
5.6 Current consumption.	63
5.6.1 Electrical specification.	64
5.7 Register description.	69
5.7.1 POWER — Power control.	69
5.7.2 CLOCK — Clock control.	75
5.7.3 REGULATORS — Voltage regulators control.	83
6 Peripherals.	85
6.1 CRYPTOCELL — Arm TrustZone CryptoCell 310.	85
6.1.1 Disclaimer.	86
6.1.2 Usage.	86
6.1.3 Security configuration.	86
6.1.4 Cryptographic flow.	87
6.1.5 Cryptographic key selection.	87
6.1.6 Internal memories.	89
6.1.7 Direct memory access (DMA).	89

6.1.8 Power and clock.	89
6.1.9 Interrupt handling.	90
6.1.10 Standards.	90
6.1.11 Registers.	91
6.1.12 Accelerators.	92
6.1.13 Host integration.	133
6.2 DPPI - Distributed programmable peripheral interconnect.	153
6.2.1 Subscribing to and publishing on channels.	154
6.2.2 DPPI configuration (DPPIC).	156
6.2.3 Connection examples.	156
6.2.4 Special considerations for a system implementing TrustZone for Cortex-M processors.	157
6.2.5 Registers.	158
6.3 EGU — Event generator unit.	161
6.3.1 Registers.	162
6.3.2 Electrical specification.	164
6.4 GPIO — General purpose input/output.	164
6.4.1 Pin configuration.	165
6.4.2 Pin sense mechanism.	166
6.4.3 GPIO security.	167
6.4.4 Registers.	169
6.4.5 Electrical specification.	173
6.5 GPIOTE — GPIO tasks and events.	174
6.5.1 Pin events and tasks.	174
6.5.2 Port event.	175
6.5.3 Tasks and events pin configuration.	175
6.5.4 Registers.	176
6.6 IPC — Interprocessor communication.	180
6.6.1 IPC and PPI connections.	182
6.6.2 Registers.	183
6.6.3 Electrical specification.	186
6.7 I2S — Inter-IC sound interface.	186
6.7.1 Mode.	187
6.7.2 Transmitting and receiving.	187
6.7.3 Left right clock (LRCK).	188
6.7.4 Serial clock (SCK).	188
6.7.5 Master clock (MCK).	189
6.7.6 Width, alignment, and format.	190
6.7.7 EasyDMA.	191
6.7.8 Module operation.	193
6.7.9 Pin configuration.	195
6.7.10 Registers.	195
6.7.11 Electrical specification.	206
6.8 KMU — Key management unit.	206
6.8.1 Functional view.	207
6.8.2 Access control.	207
6.8.3 Protecting the UICR content.	208
6.8.4 Usage.	208
6.8.5 Registers.	212
6.9 PDM — Pulse density modulation interface.	216
6.9.1 Master clock generator.	216
6.9.2 Module operation.	217
6.9.3 Decimation filter.	217
6.9.4 EasyDMA.	217
6.9.5 Hardware example.	218

6.9.6 Pin configuration.	219
6.9.7 Registers.	219
6.9.8 Electrical specification.	228
6.10 PWM — Pulse width modulation.	228
6.10.1 Wave counter.	229
6.10.2 Decoder with EasyDMA.	232
6.10.3 Limitations.	240
6.10.4 Pin configuration.	240
6.10.5 Registers.	240
6.11 RTC — Real-time counter.	251
6.11.1 Clock source.	252
6.11.2 Resolution versus overflow and the prescaler.	252
6.11.3 Counter register.	253
6.11.4 Overflow.	253
6.11.5 Tick event.	254
6.11.6 Event control.	254
6.11.7 Compare.	254
6.11.8 Task and event jitter/delay.	256
6.11.9 Registers.	258
6.12 SAADC — Successive approximation analog-to-digital converter.	266
6.12.1 Overview.	266
6.12.2 Digital output.	267
6.12.3 Analog inputs and channels.	268
6.12.4 Operation modes.	268
6.12.5 EasyDMA.	270
6.12.6 Resistor ladder.	271
6.12.7 Reference.	272
6.12.8 Acquisition time.	272
6.12.9 Limits event monitoring.	273
6.12.10 Registers.	274
6.12.11 Electrical specification.	291
6.12.12 Performance factors.	292
6.13 SPIM — Serial peripheral interface master with EasyDMA.	292
6.13.1 SPI master transaction sequence.	293
6.13.2 Master mode pin configuration.	294
6.13.3 Shared resources.	295
6.13.4 EasyDMA.	295
6.13.5 Low power.	295
6.13.6 Registers.	296
6.13.7 Electrical specification.	307
6.14 SPIS — Serial peripheral interface slave with EasyDMA.	308
6.14.1 Shared resources.	309
6.14.2 EasyDMA.	309
6.14.3 SPI slave operation.	309
6.14.4 Semaphore operation.	311
6.14.5 Pin configuration.	312
6.14.6 Registers.	312
6.14.7 Electrical specification.	322
6.15 SPU — System protection unit.	324
6.15.1 General concepts.	324
6.15.2 Flash access control.	325
6.15.3 RAM access control.	328
6.15.4 Peripheral access control.	331
6.15.5 Pin access control.	333

6.15.6 DPPI access control.	333
6.15.7 External domain access control.	335
6.15.8 TrustZone for Cortex-M ID allocation.	336
6.15.9 Registers.	337
6.16 TIMER — Timer/counter.	346
6.16.1 Capture.	347
6.16.2 Compare.	347
6.16.3 Task delays.	347
6.16.4 Task priority.	347
6.16.5 Registers.	348
6.17 TWIM — I ² C compatible two-wire interface master with EasyDMA.	355
6.17.1 Shared resources.	356
6.17.2 EasyDMA.	356
6.17.3 Master write sequence.	357
6.17.4 Master read sequence.	357
6.17.5 Master repeated start sequence.	358
6.17.6 Low power.	359
6.17.7 Master mode pin configuration.	359
6.17.8 Registers.	360
6.17.9 Electrical specification.	374
6.17.10 Pullup resistor.	375
6.18 TWIS — I ² C compatible two-wire interface slave with EasyDMA.	375
6.18.1 Shared resources.	377
6.18.2 EasyDMA.	377
6.18.3 TWI slave responding to a read command.	378
6.18.4 TWI slave responding to a write command.	379
6.18.5 Master repeated start sequence.	380
6.18.6 Terminating an ongoing TWI transaction.	381
6.18.7 Low power.	381
6.18.8 Slave mode pin configuration.	381
6.18.9 Registers.	381
6.18.10 Electrical specification.	395
6.19 UARTE — Universal asynchronous receiver/transmitter with EasyDMA.	395
6.19.1 EasyDMA.	396
6.19.2 Transmission.	396
6.19.3 Reception.	397
6.19.4 Error conditions.	399
6.19.5 Using the UARTE without flow control.	399
6.19.6 Parity and stop bit configuration.	399
6.19.7 Low power.	399
6.19.8 Pin configuration.	400
6.19.9 Registers.	400
6.19.10 Electrical specification.	418
6.20 WDT — Watchdog timer.	418
6.20.1 Reload criteria.	418
6.20.2 Temporarily pausing the watchdog.	419
6.20.3 Watchdog reset.	419
6.20.4 Registers.	419
6.20.5 Electrical specification.	423
7 LTE modem.	424
7.1 SIM card interface.	425
7.2 LTE coexistence interface.	426
7.3 LTE RF control external interface.	427

7.4	RF front-end interface.	428
7.5	Electrical specification.	428
7.5.1	Key RF parameters for Cat-M1.	428
7.5.2	Key RF parameters for Cat-NB1 and Cat-NB2.	428
7.5.3	Receiver parameters for Cat-M1.	429
7.5.4	Receiver parameters for Cat-NB1 and Cat-NB2.	429
7.5.5	Transmitter parameters for Cat-M1.	429
7.5.6	Transmitter parameters for Cat-NB1 and Cat-NB2.	429
8	GPS receiver.	430
8.1	Electrical specification.	430
9	Debug and trace.	432
9.1	Special consideration regarding debugger access.	432
9.2	DAP - Debug access port.	433
9.3	Debug interface mode.	433
9.4	Real-time debug.	434
9.5	Registers.	434
9.5.1	TARGETID.	434
9.6	Electrical specification.	435
9.6.1	Trace port.	435
9.7	Trace.	435
9.7.1	ATB Funnel.	436
9.7.2	ATB Replicator.	443
9.7.3	ETB — Embedded trace buffer.	450
9.7.4	ETM — Embedded trace macrocell.	463
9.7.5	TPIU — Trace port interface unit.	484
9.8	CTRL-AP - Control access port.	498
9.8.1	Reset request.	499
9.8.2	Erase all.	499
9.8.3	Mailbox interface.	499
9.8.4	Disabling erase protection.	500
9.8.5	Debugger registers.	500
9.8.6	Registers.	504
9.9	TAD - Trace and debug control.	506
9.9.1	Registers.	506
10	Hardware and layout.	511
10.1	Pin assignments.	511
10.1.1	LGA pin assignments.	511
10.2	Mechanical specifications.	514
10.2.1	16.0 x 10.5 mm package.	514
10.3	Reference circuitry.	514
10.3.1	Schematic SlxA LGA127.	515
10.4	Reflow conditions.	516
10.5	Shelf and floor life.	516
11	Operating conditions.	517
11.1	VDD_GPIO considerations.	517
12	Absolute maximum ratings.	518

13	Ordering information.	519
13.1	SiP marking.	519
13.2	Box labels.	519
13.3	Order code.	520
13.4	Code ranges and values.	521
13.5	Product options.	522
14	Regulatory information.	524
15	Legal notices.	525

1 Revision history

Date	Version	Description
May 2024	2.2	<p>Updated the following:</p> <ul style="list-style-type: none">• About this document on page 13 - Added Peripheral instantiation• Block diagram on page 16 - Added RF Front-End and PMIC• CPU on page 22 :<ul style="list-style-type: none">• Clarified Floating-point interrupt section• Updated CoreMark[®] compiler and values• Instantiation on page 27 :<ul style="list-style-type: none">• Removed FPU Secure Base address• Added CRYPTOCELL components• Added Embedded Trace Buffer components• Added TrustZone information• Power and clock management on page 52 :<ul style="list-style-type: none">• Updated Power supply supervisor thresholds• Defined HFXO Startup time• Updated LFXO Frequency tolerance• Updated Reset behavior for the main components• Updated CoreMark[®] current consumption• Updated SAADC current consumption• Peripherals on page 85 :<ul style="list-style-type: none">• Added TrustZone information• CRYPTOCELL — Arm TrustZone CryptoCell 310 on page 85 - Updated description• I2S — Inter-IC sound interface on page 186 - Updated I2S timing specification description• PWM — Pulse width modulation on page 228 - Updated Wave counter description• SAADC — Successive approximation analog-to-digital converter on page 266 :<ul style="list-style-type: none">• Updated Calibration description• Updated Electrical Specification• SPIS — Serial peripheral interface slave with EasyDMA on page 308 :<ul style="list-style-type: none">• Updated SPI modes Clock phase description• Removed deprecated register definitions• LTE modem on page 424 :<ul style="list-style-type: none">• Updated LTE coexistence interface• Removed Cat-M1 B14• Debug and trace on page 432 - Added Embedded trace buffer (ETB)• Pin assignments on page 511 - Updated nRESET pin description• Operating conditions on page 517- Updated RF 3GPP minimum voltage <p>Editorial changes</p>
October 2021	2.1	<p>Updated the following:</p> <ul style="list-style-type: none">• Absolute maximum ratings on page 518 - Updated maximum values for ATEX parameters Li and Ci• AHB multilayer interconnect on page 50 - Added AHB priority list table• CPU on page 22 - Added FPU section• Current consumption on page 63:

Date	Version	Description
		<ul style="list-style-type: none"> Added application MCU sleep RAM leakage information Updated GPS continuous tracking typical peak current without power saving mode Updated UARTE current unit Added sleep current numbers i_MCUON2, i_MCUON3, and i_MCUON4 FICR — Factory information configuration registers on page 38 - Replaced INFO.PART/VARIANT/PACKAGE with INFO.SIPINFO.PART/HWREVISION/VARIANT GPIO Electrical Specification on page 173 - Added clarification about VDD_GPIO GPS receiver on page 430: <ul style="list-style-type: none"> Added QZSS support Added 1PPS information including accuracy electrical specification LTE modem on page 424: <ul style="list-style-type: none"> Editorial changes Removed B17 band for CAT-M1 POWER — Power control on page 69 - Added information on LTEMODEM.STARTN and LTEMODEM.FORCEOFF registers Power supply monitoring on page 55: <ul style="list-style-type: none"> Added information on device external power failure warning feature Added device startup times for tR2ON, tOFF2ON, tWFE2CPU, and tWFI2CPU REGULATORS — Voltage regulators control on page 83 - Added EXTPOFCON register information SPIS — Serial peripheral interface slave with EasyDMA on page 308 - Updated SPIS timing Added Shelf and floor life on page 516 UICR — User information configuration registers on page 44 - Added APPNVMCPOFGUARD information
September 2020	2.0	<p>Updated the following:</p> <ul style="list-style-type: none"> Updated format of all figures Removed deprecated columns in all register tables CPU on page 22 - Updated CoreMark[®] values Power supply monitoring on page 55 - Added LTE modem startup and shutdown information to Device startup times Current consumption on page 63: <ul style="list-style-type: none"> Updated application domain, LTE modem, and GPS receiver information Added LTE modem PSM TAU event energy and duration information Updated parameters PWM — Pulse width modulation on page 228 - Added code example for typical configuration SPU — System protection unit on page 324 - Editorial updates UARTE — Universal asynchronous receiver/transmitter with EasyDMA on page 395 - Added parameters Pin assignments on page 511 - Updated description for SIM_DET pin Absolute maximum ratings on page 518 - Updated ATEX compliance parameters Ordering information on page 519 - Updated Order code Legal notices on page 525 - Updated text for Life support applications
April 2020	1.2	<p>Updated the following:</p> <ul style="list-style-type: none"> Operating conditions on page 517 – Updated with MAGPIO, COEX, MIPI RFFE, SIMIF pins voltage supply references Absolute maximum ratings on page 518: <ul style="list-style-type: none"> Updated with GPS antenna input level and ATEX compliance information Decreased maximum storage temperature to 95 °C Power and clock management: <ul style="list-style-type: none"> Updated ENABLE pin information

Date	Version	Description
		<ul style="list-style-type: none"> • Added SYSTEM DISABLED mode information • Updated Pin reset voltage level and pull-up information • Current consumption on page 63: <ul style="list-style-type: none"> • Updated peripherals consumption information • Added SYSTEM DISABLED mode information • Updated LTE modem Cat-M1 information • Added Cat-NB1 information • Updated GPS receiver information • LTE modem: <ul style="list-style-type: none"> • Added MAGPIO, COEX, and MIPI RFFE timing information • Added NB2 mode and COEX features availability information • Added information on SIM card power down support during eDRX idle mode • GPS receiver on page 430 - updated with performance information • Pin reset on page 61 - updated description and added schematic • Current consumption on page 63 - I_{GPS_SINGLE} value increased due to design changes to improve performance in poor conditions <p>Added:</p> <ul style="list-style-type: none"> • Reflow conditions on page 516
October 2019	1.1	<p>Updated:</p> <ul style="list-style-type: none"> • Debug and trace Debug and trace on page 432: Added debug access port. Updated SDK version • Memory on page 23: Added a reference • LGA pin assignments on page 511: Several updates • Operating conditions on page 517: Changed chapter name. Updated MAGPIO values. Updated VDD_GPIO restrictions. • Ordering information on page 519: Updated Product options <p>Added:</p> <ul style="list-style-type: none"> • Reference circuitry on page 514
May 2019	1.0	First release

2 About this document

This document is organized into chapters that are based on the modules and peripherals available in the IC.

2.1 Document status

The document status reflects the level of maturity of the document.

Document name	Description
Objective Product Specification (OPS)	Applies to document versions up to 1.0. This document contains target specifications for product development.
Product Specification (PS)	Applies to document versions 1.0 and higher. This document contains final product specifications. Nordic Semiconductor ASA reserves the right to make changes at any time without notice in order to improve design and supply the best possible product.

Table 1: Defined document names

2.2 Peripheral chapters

Every peripheral has a unique capitalized name or an abbreviation of its name, e.g. TIMER, used for identification and reference. This name is used in chapter headings and references, and it will appear in the Arm Cortex Microcontroller Software Interface Standard (CMSIS) hardware abstraction layer to identify the peripheral.

The peripheral instance name, which is different from the peripheral name, is constructed using the peripheral name followed by a numbered postfix, starting with 0, for example, TIMER0. A postfix is normally only used if a peripheral can be instantiated more than once. The peripheral instance name is also used in the CMSIS to identify the peripheral instance.

The chapters describing peripherals may include the following information:

- A detailed functional description of the peripheral.
- The register configuration for the peripheral.
- The electrical specification tables, containing performance data which apply for the operating conditions described in [Operating conditions](#) on page 517.

2.2.2 Peripheral instantiation

The peripherals have a set of security capabilities listed in the instantiation tables.

The following table describes the abbreviations used.

Abbreviation	Description
NS	Trustzone/security attribute is Non-secure - The peripheral is always accessible as a Non-secure peripheral.
S	Trustzone/security attribute is Secure - The peripheral is always accessible as a Secure peripheral.
US	Trustzone Map is user selectable - The Trustzone/security attribute of the peripheral is configurable.
HF	Trustzone Map is Hardware Fixed - The Trustzone/security attribute of the peripheral cannot be changed.
NA	Not Applicable - Peripheral has no DMA capability.
NSA	NoSeparateAttribute - Peripheral with DMA and DMA transfer has the same security attribute as assigned to the peripheral.
SA	SeparateAttribute - Peripheral with DMA and DMA transfers can have a different security attribute than the one assigned to the peripheral.

Table 2: Instantiation table abbreviations

The Secure mapping column in the peripheral instantiation table defines configuration capabilities for the Arm TrustZone for Armv8-M secure attribute. The DMA security column describes the DMA capabilities of the peripheral.

The instantiation table has the following columns:

- Instance Column - Indicates the peripheral instance name followed by optional Trustzone attribute. A corresponding address is listed in Base address column indicating the base address for Secure and Non-secure Trustzone attribute. This optional Trustzone attribute is separated by a colon (:).
- Trustzone Column - This has 3 sub-columns indicating the Trustzone map, Trustzone attribute and DMA capability. The options are as listed in [Instantiation table abbreviations](#) on page 14.

2.3 Register tables

Individual registers are described using register tables. These tables are built up of two sections. The first three colored rows describe the position and size of the different fields in the register. The following rows describe the fields in more detail.

2.3.1 Fields and values

The **Id (Field Id)** row specifies the bits that belong to the different fields in the register. If a field has enumerated values, then every value will be identified with a unique value id in the **Value Id** column.

A blank space means that the field is reserved and read as undefined, and it also must be written as 0 to secure forward compatibility. If a register is divided into more than one field, a unique field name is specified for each field in the **Field** column. The **Value Id** may be omitted in the single-bit bit fields when values can be substituted with a Boolean type enumerator range, e.g. true/false, disable(d)/enable(d), on/off, and so on.

Values are usually provided as decimal or hexadecimal. Hexadecimal values have a 0x prefix, decimal values have no prefix.

The **Value** column can be populated in the following ways:

- Individual enumerated values, for example 1, 3, 9.
- Range of values, e.g. [0..4], indicating all values from and including 0 and 4.

- Implicit values. If no values are indicated in the **Value** column, all bit combinations are supported, or alternatively the field's translation and limitations are described in the text instead.

If two or more fields are closely related, the **Value Id**, **Value**, and **Description** may be omitted for all but the first field. Subsequent fields will indicate inheritance with '..!'.
 A feature marked **Deprecated** should not be used for new designs.

2.3.2 Permissions

Different fields in a register might have different access permissions enforced by hardware.

The access permission for each register field is documented in the **Access** column in the following ways:

Access	Description	Hardware behavior
RO	Read-only	Field can only be read. A write will be ignored.
WO	Write-only	Field can only be written. A read will return an undefined value.
RW	Read-write	Field can be read and written multiple times.
W1	Write-once	Field can only be written once per reset. Any subsequent write will be ignored. A read will return an undefined value.
RW1	Read-write-once	Field can be read multiple times, but only written once per reset. Any subsequent write will be ignored.
W1C	Write 1 to clear	Field can be read multiple times. A one clears (set to zero) the corresponding bit in the register. Bits set to zero are ignored.
W1S	Write 1 to set	Field can be read multiple times. A one sets the corresponding bit in the register. Bits set to zero are ignored.

Table 3: Register field permission schemes

2.4 Registers

Register overview

Register	Offset	Description
DUMMY	0x514	Example of a register controlling a dummy feature

2.4.1 DUMMY

Address offset: 0x514

Example of a register controlling a dummy feature

Bit number	31 30 29 28 27 26 25 24 23 22 21 20 19 18 17 16 15 14 13 12 11 10 9 8 7 6 5 4 3 2 1 0																														
ID	D D D D				C C C			B			A																				
Reset 0x00050002	0 0 0 0 0 0 0 0 0 0 0 0 0 0 1 0 1 0 0 0 0 0 0 0 0 0 0 0 0 0 0 0 0																														
ID	R/W	Field	Value ID	Value	Description																										
-A	RW	FIELD0			Example of a read-write field with several enumerated values																										
			Disabled	0	The example feature is disabled																										
			NormalMode	1	The example feature is enabled in normal mode																										
			ExtendedMode	2	The example feature is enabled along with extra functionality																										
B	RW	FIELD1			Example of a deprecated read-write field																										
					This field is deprecated.																										
			Disabled	0	The override feature is disabled																										
	Enabled	1	The override feature is enabled																												
C	RW	FIELD2			Example of a read-write field with a valid range of values																										
			ValidRange	[2..7]	Example of allowed values for this field																										
D	RW	FIELD3			Example of a read-write field with no restriction on the values																										

3 Product overview

The nRF9160 System-in-Package (SiP) is a low-power cellular IoT (Internet of Things) solution, integrating an Arm Cortex-M33 processor with advanced security features, a range of peripherals, as well as a complete LTE modem compliant with 3GPP LTE release 13 Cat-M1 and Cat-NB1, and 3GPP LTE release 14 Cat-NB1 and Cat-NB2 standards.

The Arm Cortex-M33 processor is exclusively for user application software, and it offers 1 MB of flash and 256 kB of RAM dedicated to this use. The M33 application processor shares the power, clock, and peripheral architecture with Nordic Semiconductor nRF51 and nRF52 Series of PAN/LAN SoCs, ensuring minimal porting efforts.

The peripheral set offers a variety of analog and digital functionality enabling single-chip implementation of a wide range of cellular IoT (Internet of Things) applications. Arm TrustZone technology, CryptoCell 310 and supporting blocks for system protection and key management, are embedded to enable advanced security needed for IoT applications.

The LTE modem integrates a very flexible transceiver that in hardware supports frequency range from 700 to 2200 MHz (through a single 50 Ω antenna pin), and a baseband processor handling LTE Cat-M1/NB1/NB2 protocol layers L1-L3 as well as IP upper layers offering secure socket API for the application. The modem is supported by prequalified software builds available for free from Nordic Semiconductor.

On specific nRF9160 device variants, the LTE modem supports A-GPS operation during sleep intervals in the LTE operation (RRC idle and PSM modes).

Note: The LTE modem hardware supports Cat-NB2, but needs modem firmware support to get enabled. For information on Cat-NB2 feature support, see the *nRF9160 Modem Firmware Release Notes* included in the latest [nRF9160 modem firmware](#).

3.1 Block diagram

The block diagram illustrates the overall system. Arrows with white heads indicate signals that share physical pins with other signals.

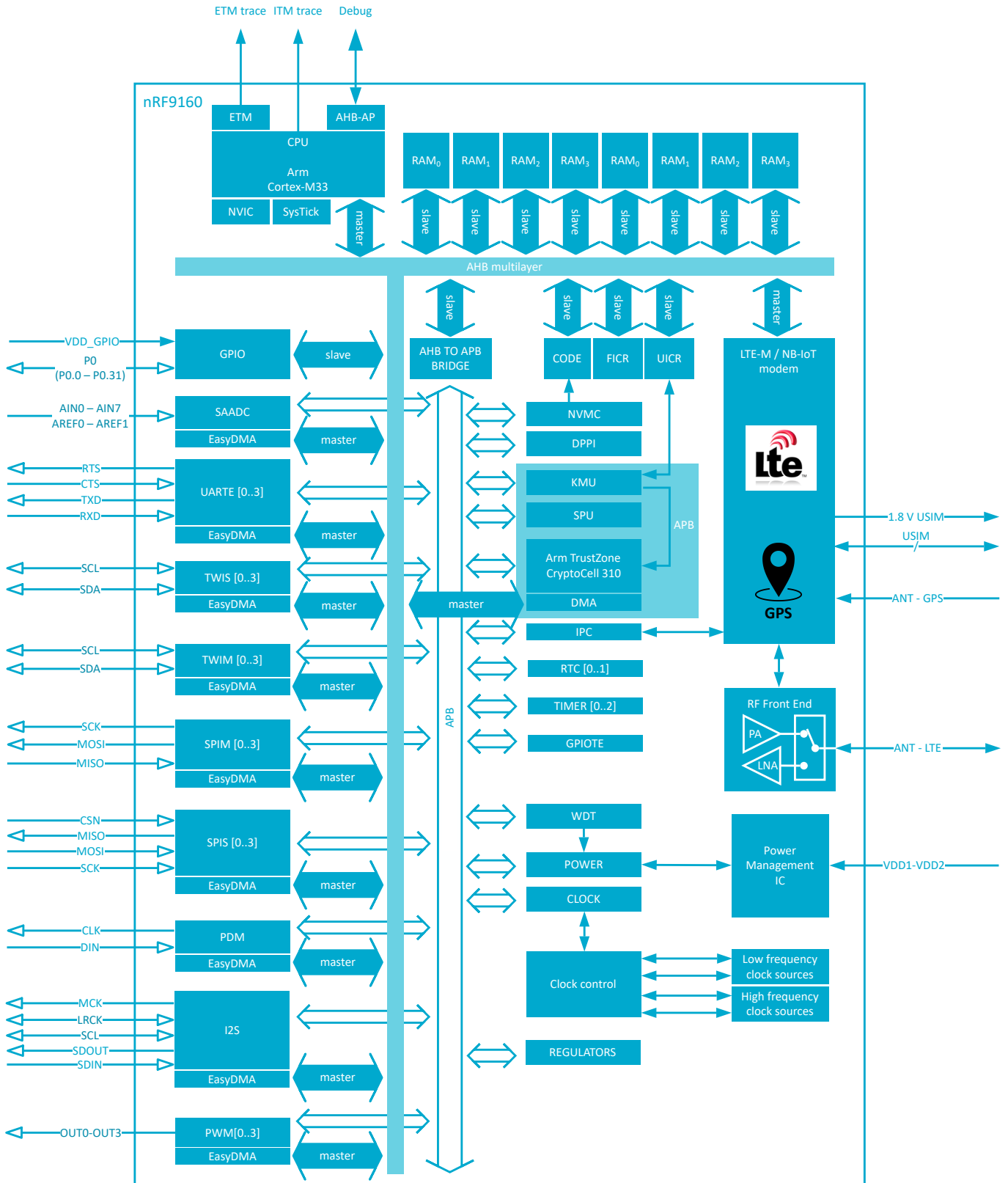

Figure 1: Block diagram

3.2 Peripheral interface

Peripherals are controlled by the CPU through configuration registers, as well as task and event registers. Task registers are inputs, enabling the CPU and other peripherals to initiate a functionality. Event registers

are outputs, enabling a peripheral to trigger tasks in other peripherals and/or the CPU by tying events to CPU interrupts.

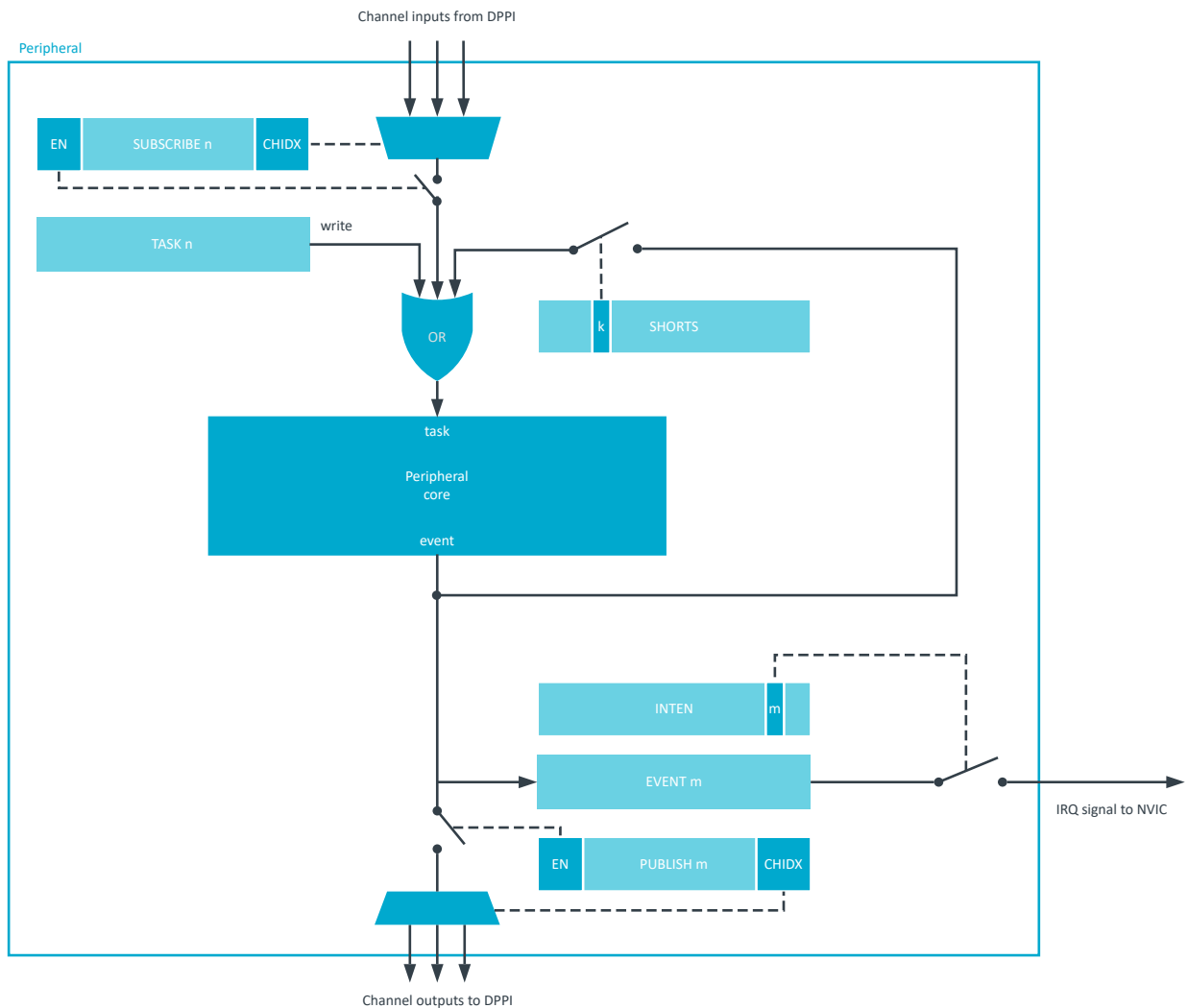

Figure 2: Peripheral interface

The distributed programmable peripheral interconnect (DPPI) feature enables peripherals to connect events to tasks without CPU intervention. For more information on DPPI and the DPPI channels, see [DPPI - Distributed programmable peripheral interconnect](#) on page 153.

3.2.1 Peripheral ID

Every peripheral is assigned a fixed block of 0x1000 bytes of address space, which is equal to 1024 x 32-bit registers.

See [Instantiation](#) on page 27 for more information about which peripherals are available and where they are located in the address map.

There is a direct relationship between peripheral ID and base address. For example, a peripheral with base address 0x40000000 is assigned ID=0, a peripheral with base address 0x40001000 is assigned ID=1, and a peripheral with base address 0x4001F000 is assigned ID=31.

Peripherals may share the same ID, which may impose one or more of the following limitations:

- Shared registers or common resources
- Limited availability due to mutually exclusive operation; only one peripheral in use at a time

- Enforced peripheral behavior when switching between peripherals (disable the first peripheral before enabling the second)

3.2.2 Peripherals with shared ID

In general (with the exception of ID 0), peripherals sharing an ID and base address may not be used simultaneously. Only one peripheral can be enabled at a given ID.

When switching between two peripherals sharing an ID, the following should be performed to prevent unwanted behavior:

1. Disable the previously used peripheral.
2. Disable any publish/subscribe connection to the DPPI system for the peripheral that is being disabled.
3. Clear all bits in the INTEN register, i.e. `INTENCLR = 0xFFFFFFFF`.
4. Explicitly configure the peripheral being enabled. Do not rely on inherited configuration from the disabled peripheral.
5. Enable the now configured peripheral.

For a list of which peripherals that share an ID see [Instantiation](#) on page 27.

3.2.3 Peripheral registers

Most peripherals feature an ENABLE register. Unless otherwise specified, the peripheral registers must be configured before enabling the peripheral.

PSEL registers need to be set before a peripheral is enabled or started. Updating PSEL registers while the peripheral is running has no effect. To connect a peripheral to a different GPIO, the following must be performed:

1. Disable the peripheral.
2. Update the PSEL register.
3. Re-enable the peripheral.

It takes four CPU cycles between the PSEL register update and the connection between a peripheral and a GPIO becoming effective.

Note: The peripheral must be enabled before tasks and events can be used.

Most of the register values are lost during System OFF or when a reset is triggered. Some registers will retain their values in System OFF or for some specific reset sources. These registers are marked as retained in the register description for a given peripheral. For more information on their behavior, see chapter [Reset](#) on page 61.

3.2.4 Bit set and clear

Registers with multiple single-bit bit fields may implement the set-and-clear pattern. This pattern enables firmware to set and clear individual bits in a register without having to perform a read-modify-write operation on the main register.

This pattern is implemented using three consecutive addresses in the register map, where the main register is followed by dedicated SET and CLR registers (in that exact order).

In the main register, the SET register sets individual bits and the CLR register clears them. Writing 1 to a bit in the SET or CLR register will set or clear the same bit in the main register respectively. Writing 0 to a bit in the SET or CLR register has no effect. Reading the SET or CLR register returns the value of the main register.

Note: The main register may not be visible and therefore not directly accessible in all cases.

3.2.5 Tasks

Tasks are used to trigger actions in a peripheral, such as to start a particular behavior. A peripheral can implement multiple tasks with each task having a separate register in that peripheral's task register group.

A task is triggered when firmware writes 1 to the task register, or when the peripheral itself or another peripheral toggles the corresponding task signal. See the figure [Peripheral interface](#) on page 18.

3.2.6 Events

Events are used to notify peripherals and the CPU about events that have happened, for example a state change in a peripheral. A peripheral may generate multiple events, where each event has a separate register in that peripheral's event register group.

An event is generated when the peripheral itself toggles the corresponding event signal, and the event register is updated to reflect that the event has been generated, see figure [Peripheral interface](#) on page 18. An event register is cleared when a 0 is written to it by firmware. Events can be generated by the peripheral even when the event register is set to 1.

3.2.7 Publish and subscribe

Events and tasks from different peripherals can be connected together through the DPPI system using the PUBLISH and SUBSCRIBE registers in each peripheral. See [Peripheral interface](#) on page 18. An event can be published onto a DPPI channel by configuring the event's PUBLISH register. Similarly, a task can subscribe to a DPPI channel by configuring the task's SUBSCRIBE register.

See [DPPI - Distributed programmable peripheral interconnect](#) on page 153 for details.

3.2.8 Shortcuts

A shortcut is a direct connection between an event and a task within the same peripheral. If a shortcut is enabled, the associated task is automatically triggered when its associated event is generated.

Using shortcuts is equivalent to making the connection outside the peripheral and through the DPPI. However, the propagation delay when using shortcuts is usually shorter than the propagation delay through the DPPI.

Shortcuts are predefined, which means that their connections cannot be configured by firmware. Each shortcut can be individually enabled or disabled through the shortcut register, one bit per shortcut, giving a maximum of 32 shortcuts for each peripheral.

3.2.9 Interrupts

All peripherals support interrupts which are generated by events.

A peripheral only occupies one interrupt, and the interrupt number follows the peripheral ID. For example, the peripheral with ID=4 is connected to interrupt number 4 in the nested vectored interrupt controller (NVIC).

Using registers INTEN, INTENSET, and INTENCLR, every event generated by a peripheral can be configured to generate that peripheral's interrupt. Multiple events can be enabled to generate interrupts simultaneously. To resolve the correct interrupt source, the event registers in the event group of peripheral registers will indicate the source.

Some peripherals implement only INTENSET and INTENCLR registers, and the INTEN register is not available on those peripherals. See the individual peripheral chapters for details. In all cases, reading back the INTENSET or INTENCLR register returns the same information as in INTEN.

Each event implemented in the peripheral is associated with a specific bit position in the INTEN, INTENSET, and INTENCLR registers.

The relationship between tasks, events, shortcuts, and interrupts is illustrated in figure [Peripheral interface](#) on page 18.

3.2.9.1 Interrupt clearing and disabling

Interrupts should always be cleared by writing 0 to the corresponding EVENT register.

Until cleared, interrupts will immediately be re-triggered and cause software interrupt service routines to be executed repeatedly.

Because the clearing of the EVENT register may take a number of CPU clock cycles, the program should perform a read from the EVENT register that has been cleared before exiting the interrupt service routine. This will ensure that the EVENT clearing has taken place before the interrupt service routine is exited. Care should be taken to ensure that the compiler does not remove the read operation as an optimization.

Similarly, when disabling an interrupt inside an interrupt service routine, the program should perform a read from the INTEN or INTENCLR registers to ensure that the interrupt is disabled before exiting the interrupt service routine.

3.2.10 Secure/non-secure peripherals

For some peripherals, the security configuration can change from secure to non-secure, or vice versa. Care must be taken when changing the security configuration of a peripheral, to prevent security information leakage and ensure correct operation.

The following sequence should be followed, where applicable, when configuring and changing the security settings of a peripheral in the [SPU — System protection unit](#) on page 324.

1. Stop peripheral operation.
2. Disable the peripheral.
3. Remove pin connections.
4. Disable DPPI connections.
5. Clear sensitive registers (e.g. writing back default values).
6. Change peripheral security setting in the [SPU — System protection unit](#) on page 324.
7. Re-enable the peripheral.

4 Application core

The nRF9160 application core has a modern and powerful Arm Cortex-M33 with on-chip flash and RAM exclusively for application use.

4.1 CPU

The Arm Cortex-M33 processor has a 32-bit instruction set (Thumb[®]-2 technology) that implements a superset of 16 and 32-bit instructions to maximize code density and performance.

This processor implements several features that enable energy-efficient arithmetic and high-performance signal processing, including:

- Digital signal processing (DSP) instructions
- Single-cycle multiply and accumulate (MAC) instructions
- Hardware divide
- 8- and 16-bit single instruction, multiple data (SIMD) instructions
- Single-precision floating-point unit (FPU)
- Memory Protection Unit (MPU)
- Arm TrustZone for ARMv8-M

The Arm Cortex Common Microcontroller Software Interface Standard (CMSIS) hardware abstraction layer for the Arm Cortex processor series is implemented and available for the M33 CPU.

Real-time execution is highly deterministic in thread mode, to and from sleep modes, and when handling events at configurable priority levels via the nested vectored interrupt controller (NVIC).

Executing code from internal or external flash will have a wait state penalty. The instruction cache can be enabled to minimize flash wait states when fetching instructions. For more information on cache, see [Cache](#) on page 34. The section [Electrical specification](#) on page 23 shows CPU performance parameters including the wait states in different modes, CPU current and efficiency, and processing power and efficiency based on the CoreMark benchmark.

4.1.1 Floating-point interrupt

The floating-point unit (FPU) might generate exceptions when used (for example, due to overflow or underflow), which trigger the FPU interrupt.

See [Instantiation](#) on page 27 for more information about which exception number (peripheral ID) is triggered by an FPU exception.

The FPU is not affected by any security configuration. It is presented as non-secure in register PERIPHID[n].PERM. See [SPU — System protection unit](#) on page 324 for more information.

To clear the IRQ (interrupt request) line when an exception occurs, the relevant exception bit within the floating-point status and control register (FPSCR) must be cleared. For more information about the FPSCR or other FPU registers, see the *Arm Cortex-M33 Devices Generic User Guide*.

4.1.2 CPU and support module configuration

The Arm Cortex-M33 processor has a number of CPU options and support modules implemented on the device.

Option / Module	Description	Implemented
Core options		
NVIC	Nested vectored interrupt controller	YES
PRIORITIES	Priority bits	3
WIC	Wake-up interrupt controller	NO
Endianness	Memory system endianness	Little endian
DWT	Data watchpoint and trace	YES
Modules		
MPU_NS	Number of non-secure memory protection unit (MPU) regions	16
MPU_S	Number of secure MPU regions	16
SAU	Number of security attribution unit (SAU) regions	0, see SPU for more information about secure regions.
FPU	Floating-point unit	YES
DSP	Digital signal processing extension	YES
ARMv8-M TrustZone	ARMv8-M security extensions	YES
CPIF	Co-processor interface	NO
ETM	Embedded trace macrocell	YES
ITM	Instrumentation trace macrocell	YES
MTB	Micro trace buffer	NO
CTI	Cross trigger interface	YES
BPU	Breakpoint unit	YES
HTM	AMBA [®] AHB trace macrocell	NO

4.1.3 Electrical specification

4.1.3.1 CPU performance

The CPU clock speed is 64 MHz. Current and efficiency data is taken when in System ON and the CPU is executing the CoreMark benchmark. It includes power regulator and clock base currents. All other blocks are IDLE.

Symbol	Description	Min.	Typ.	Max.	Units
W _{FLASH}	CPU wait states, running from flash, cache disabled	0		4	
W _{FLASHCACHE}	CPU wait states, running from flash, cache enabled	0		2	
W _{RAM}	CPU wait states, running from RAM			0	
CM _{FLASH}	CoreMark ¹ , running from flash, cache enabled		247		CoreMark
CM _{FLASH/MHz}	CoreMark per MHz, running from flash, cache enabled		3.86		CoreMark/ MHz
CM _{FLASH/mA}	CoreMark per mA, running from flash, cache enabled		91		CoreMark/mA

4.2 Memory

The application microcontroller has embedded 1024 kB flash and 256 kB RAM for application code and data storage.

As illustrated in [Memory layout](#) on page 24, both CPU and EasyDMA are able to access RAM via the AHB multilayer interconnect. See [AHB multilayer interconnect](#) on page 50 and [EasyDMA](#) on page 48 for more information about AHB multilayer interconnect and EasyDMA respectively. The LTE modem can access all application MCU memory, but typically a small portion of RAM is dedicated to data exchange between application MCU and the modem baseband controller.

¹ Using armclang compiler

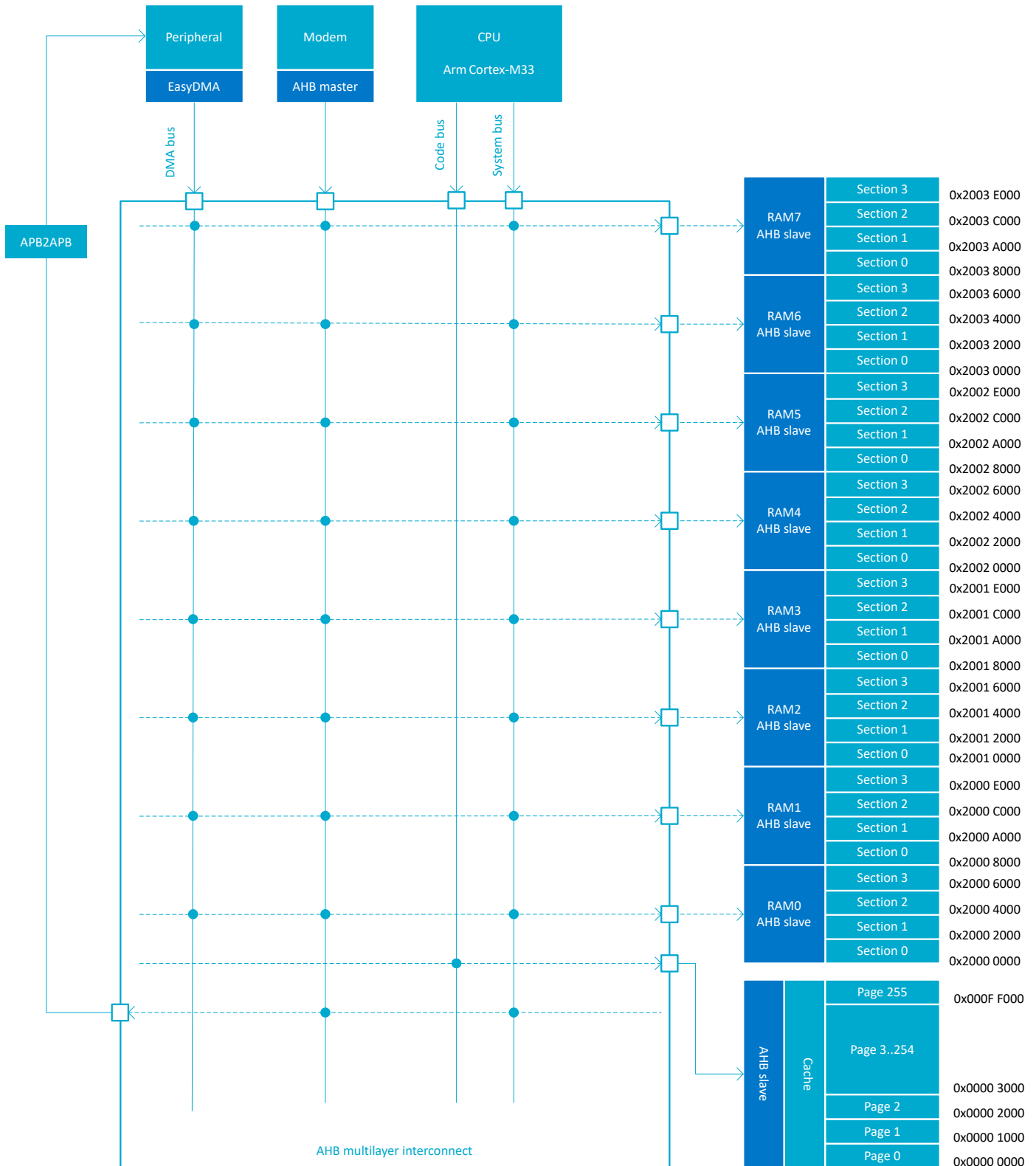

Figure 3: Memory layout

RAM - Random access memory

RAM can be read and written an unlimited number of times by the CPU and the EasyDMA.

Each RAM AHB slave is connected to one or more RAM sections. See [Memory layout](#) on page 24 for more information.

The RAM blocks power states and retention states in System ON and System OFF modes are controlled by the [VMC](#).

Flash - Non-volatile memory

Flash can be read an unlimited number of times by the CPU and is accessible via the AHB interface connected to the CPU, see [Memory layout](#) on page 24 for more information. There are restrictions on the number of times flash can be written and erased, and also on how it can be written. For more information, see [Absolute maximum ratings](#) on page 518. Writing to flash is managed by the non-volatile memory controller (NVMC).

4.2.1 Memory map

All memory and registers are found in the same address space, as illustrated in the device memory map below.

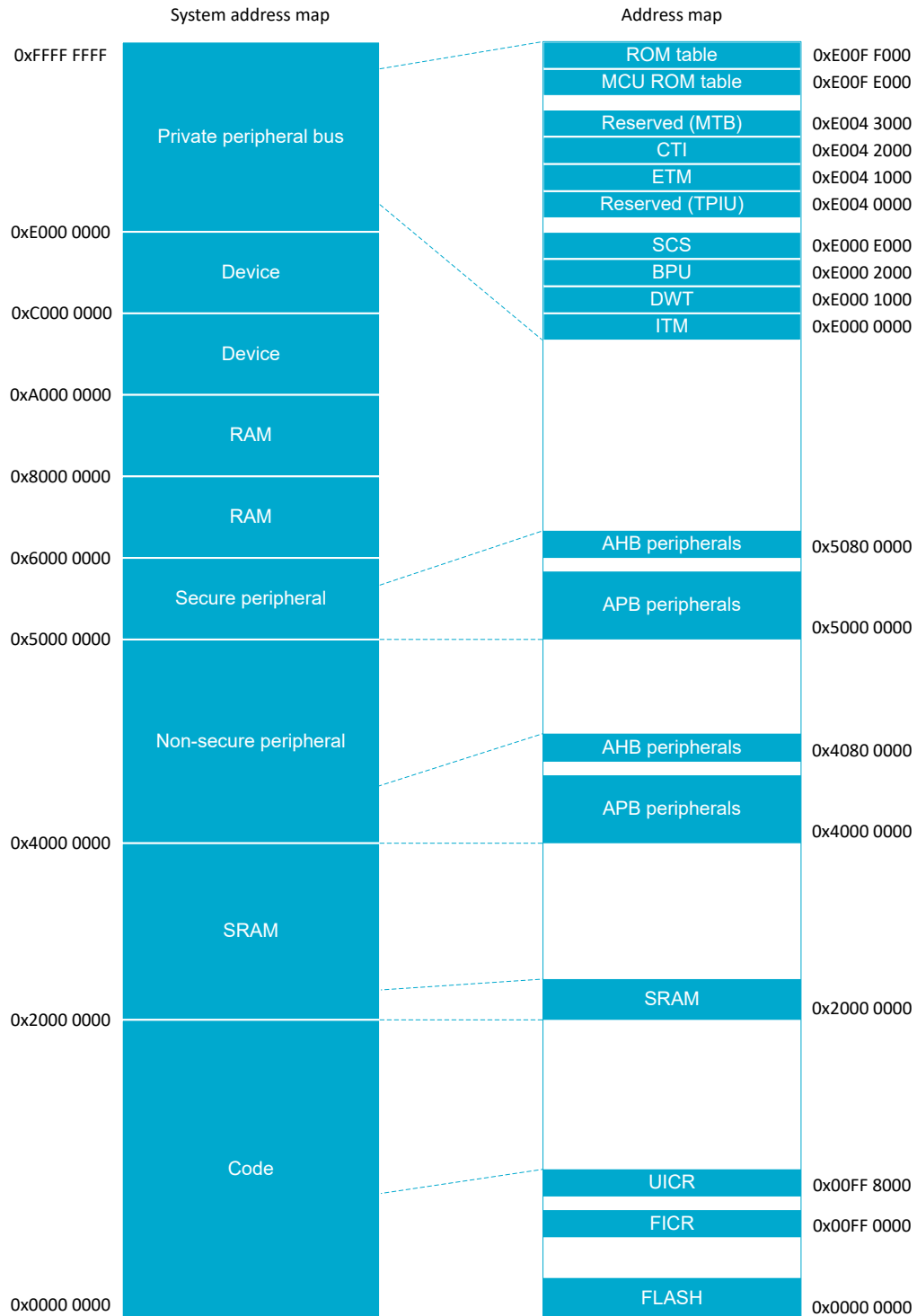

Figure 4: Memory map

Some of the registers are retained (their values kept). Read more about retained registers in [Retained registers](#) on page 62 and [Reset behavior](#) on page 62.

4.2.2 Instantiation

ID	Base address	Instance	TrustZone			Split access	Description
			Map	Att	DMA		
3	0x50003000	SPU	HF	S	NA	No	System Protection Unit
4	0x50004000	REGULATORS : S	US	NS	NA	No	Regulator configuration
	0x40004000	REGULATORS : NS					
5	0x50005000	CLOCK : S	US	NS	NA	No	Clock control
	0x40005000	CLOCK : NS					
5	0x50005000	POWER : S	US	NS	NA	No	Power control
	0x40005000	POWER : NS					
6	0x50006000	CTRL_AP_PERI	HF	S	NA	No	CTRL-AP-PERI
8	0x50008000	SPIM0 : S	US	NS	SA	No	SPI master 0
	0x40008000	SPIM0 : NS					
8	0x50008000	SPIS0 : S	US	NS	SA	No	SPI slave 0
	0x40008000	SPIS0 : NS					
8	0x50008000	TWIM0 : S	US	NS	SA	No	Two-wire interface master 0
	0x40008000	TWIM0 : NS					
8	0x50008000	TWIS0 : S	US	NS	SA	No	Two-wire interface slave 0
	0x40008000	TWIS0 : NS					
8	0x50008000	UARTE0 : S	US	NS	SA	No	Universal asynchronous receiver/transmitter with EasyDMA 0
	0x40008000	UARTE0 : NS					
9	0x50009000	SPIM1 : S	US	NS	SA	No	SPI master 1
	0x40009000	SPIM1 : NS					
9	0x50009000	SPIS1 : S	US	NS	SA	No	SPI slave 1
	0x40009000	SPIS1 : NS					
9	0x50009000	TWIM1 : S	US	NS	SA	No	Two-wire interface master 1
	0x40009000	TWIM1 : NS					
9	0x50009000	TWIS1 : S	US	NS	SA	No	Two-wire interface slave 1
	0x40009000	TWIS1 : NS					
9	0x50009000	UARTE1 : S	US	NS	SA	No	Universal asynchronous receiver/transmitter with EasyDMA 1
	0x40009000	UARTE1 : NS					
10	0x5000A000	SPIM2 : S	US	NS	SA	No	SPI master 2
	0x4000A000	SPIM2 : NS					
10	0x5000A000	SPIS2 : S	US	NS	SA	No	SPI slave 2
	0x4000A000	SPIS2 : NS					
10	0x5000A000	TWIM2 : S	US	NS	SA	No	Two-wire interface master 2
	0x4000A000	TWIM2 : NS					
10	0x5000A000	TWIS2 : S	US	NS	SA	No	Two-wire interface slave 2
	0x4000A000	TWIS2 : NS					
10	0x5000A000	UARTE2 : S	US	NS	SA	No	Universal asynchronous receiver/transmitter with EasyDMA 2
	0x4000A000	UARTE2 : NS					
11	0x5000B000	SPIM3 : S	US	NS	SA	No	SPI master 3
	0x4000B000	SPIM3 : NS					
11	0x5000B000	SPIS3 : S	US	NS	SA	No	SPI slave 3
	0x4000B000	SPIS3 : NS					
11	0x5000B000	TWIM3 : S	US	NS	SA	No	Two-wire interface master 3
	0x4000B000	TWIM3 : NS					
11	0x5000B000	TWIS3 : S	US	NS	SA	No	Two-wire interface slave 3
	0x4000B000	TWIS3 : NS					
11	0x5000B000	UARTE3 : S	US	NS	SA	No	Universal asynchronous receiver/transmitter with EasyDMA 3
	0x4000B000	UARTE3 : NS					
13	0x5000D000	GPIOE0	HF	S	NA	No	Secure GPIO tasks and events

ID	Base address	Instance	TrustZone			Split access	Description
			Map	Att	DMA		
14	0x5000E000	SAADC : S	US	NS	SA	No	Analog to digital converter
	0x4000E000	SAADC : NS					
15	0x5000F000	TIMER0 : S	US	NS	NA	No	Timer 0
	0x4000F000	TIMER0 : NS					
16	0x50010000	TIMER1 : S	US	NS	NA	No	Timer 1
	0x40010000	TIMER1 : NS					
17	0x50011000	TIMER2 : S	US	NS	NA	No	Timer 2
	0x40011000	TIMER2 : NS					
20	0x50014000	RTC0 : S	US	NS	NA	No	Real time counter 0
	0x40014000	RTC0 : NS					
21	0x50015000	RTC1 : S	US	NS	NA	No	Real time counter 1
	0x40015000	RTC1 : NS					
23	0x50017000	DPPIC : S	HF	NS	NA	Yes	DPPI configuration
	0x40017000	DPPIC : NS					
24	0x50018000	WDT : S	US	NS	NA	No	Watchdog timer
	0x40018000	WDT : NS					
27	0x5001B000	EGU0 : S	US	NS	NA	No	Event generator unit 0
	0x4001B000	EGU0 : NS					
28	0x5001C000	EGU1 : S	US	NS	NA	No	Event generator unit 1
	0x4001C000	EGU1 : NS					
29	0x5001D000	EGU2 : S	US	NS	NA	No	Event generator unit 2
	0x4001D000	EGU2 : NS					
30	0x5001E000	EGU3 : S	US	NS	NA	No	Event generator unit 3
	0x4001E000	EGU3 : NS					
31	0x5001F000	EGU4 : S	US	NS	NA	No	Event generator unit 4
	0x4001F000	EGU4 : NS					
32	0x50020000	EGU5 : S	US	NS	NA	No	Event generator unit 5
	0x40020000	EGU5 : NS					
33	0x50021000	PWM0 : S	US	NS	SA	No	Pulse width modulation unit 0
	0x40021000	PWM0 : NS					
34	0x50022000	PWM1 : S	US	NS	SA	No	Pulse width modulation unit 1
	0x40022000	PWM1 : NS					
35	0x50023000	PWM2 : S	US	NS	SA	No	Pulse width modulation unit 2
	0x40023000	PWM2 : NS					
36	0x50024000	PWM3 : S	US	NS	SA	No	Pulse width modulation unit 3
	0x40024000	PWM3 : NS					
38	0x50026000	PDM : S	US	NS	SA	No	Pulse density modulation (digital microphone) interface
	0x40026000	PDM : NS					
40	0x50028000	I2S : S	US	NS	SA	No	Inter-IC Sound
	0x40028000	I2S : NS					
42	0x5002A000	IPC : S	US	NS	NA	No	Interprocessor communication
	0x4002A000	IPC : NS					
44	0x4002C000	FPU	HF	NS	NA	No	Floating-point unit
49	0x40031000	GPIOTE1	HF	NS	NA	No	Non Secure GPIO tasks and events
57	0x50039000	KMU : S	HF	NS	NA	Yes	Key management unit
	0x40039000	KMU : NS					
57	0x50039000	NVMC : S	HF	NS	NA	Yes	Non-volatile memory controller
	0x40039000	NVMC : NS					
58	0x5003A000	VMC : S	US	NS	NA	No	Volatile memory controller
	0x4003A000	VMC : NS					
64	0x50840000	CRYPTOCELL	HF	S	NSA	No	CRYPTOCELL 310 security subsystem
65	0x50841000	CC_AES	HF	S	NSA	No	CRYPTOCELL AES engine

ID	Base address	Instance	TrustZone			Split access	Description
			Map	Att	DMA		
65	0x50841000	CC_AHB	HF	S	NSA	No	CRYPTOCELL AHB interface
65	0x50841000	CC_CHACHA	HF	S	NSA	No	CRYPTOCELL CHACHA engine
65	0x50841000	CC_CTL	HF	S	NSA	No	CRYPTOCELL CTL interface
65	0x50841000	CC_DIN	HF	S	NSA	No	CRYPTOCELL DIN DMA engine
65	0x50841000	CC_DOUT	HF	S	NSA	No	CRYPTOCELL DOUT DMA engine
65	0x50841000	CC_HASH	HF	S	NSA	No	CRYPTOCELL HASH engine
65	0x50841000	CC_HOST_RGF	HF	S	NSA	No	CRYPTOCELL HOST register interface
65	0x50841000	CC_MISC	HF	S	NSA	No	CRYPTOCELL MISC interface
65	0x50841000	CC_PKI	HF	S	NSA	No	CRYPTOCELL PKI engine
65	0x50841000	CC_RNG	HF	S	NSA	No	CRYPTOCELL RNG engine
65	0x50841000	CC_RNG_SRAM	HF	S	NSA	No	CRYPTOCELL RNG SRAM interface
66	0x50842500	PO : S	HF	NS	NA	Yes	General purpose input and output
	0x40842500	PO : NS					
N/A	0x00FF0000	FICR	HF	S	NA	No	Factory information configuration
N/A	0x00FF8000	UICR	HF	S	NA	No	User information configuration
N/A	0xE0041000	ETM	HF	NS	NA	No	ETM
N/A	0xE0051000	ETB	HF	NS	NA	No	ETB
N/A	0xE0054000	TPIU	HF	NS	NA	No	TPIU
N/A	0xE0058000	ATBREPLICATOR	HF	NS	NA	No	ATBREPLICATOR
N/A	0xE005A000	ATBFUNNEL1	HF	NS	NA	No	ATBFUNNEL unit 1
N/A	0xE005B000	ATBFUNNEL2	HF	NS	NA	No	ATBFUNNEL unit 2
N/A	0xE0080000	TAD	HF	S	NA	No	Trace and debug control

Table 4: Instantiation table

4.2.3 Peripheral access control capabilities

Information about the peripheral access control capabilities can be found in the instantiation table.

The instantiation table has two columns containing the information about access control capabilities for a peripheral:

- Secure mapping: This column defines configuration capabilities for TrustZone-M secure attribute.
- DMA security: This column indicates whether the peripheral has DMA capabilities, and if DMA transfer can be assigned to a different security attribute than the peripheral itself.

For details on options in secure mapping column and DMA security column, see the following tables respectively.

Abbreviation	Description
NS	Non-secure: This peripheral is always accessible as a non-secure peripheral.
S	Secure: This peripheral is always accessible as a secure peripheral.
US	User-selectable: Non-secure or secure attribute for this peripheral is defined by the PERIPHID[0].PERM register.
SPLIT	Both non-secure and secure: The same resource is shared by both secure and non-secure code.

Table 5: Secure mapping column options

Abbreviation	Description
NA	Not applicable: Peripheral has no DMA capability.
NSA	No separate attribute: Peripheral has DMA, and DMA transfers always have the same security attribute as assigned to the peripheral.
SA	Separate attribute: Peripheral has DMA, and DMA transfers can have a different security attribute than the one assigned to the peripheral.

Table 6: DMA security column options

4.3 VMC — Volatile memory controller

The volatile memory controller (VMC) provides power control of RAM blocks.

Each of the available RAM blocks, which can contain multiple RAM sections, can be turned on or off independently in System ON mode, using the RAM[n] registers. These registers also control if a RAM block, or some of its sections, is retained in System OFF mode. See [Memory](#) chapter for more information about RAM blocks and sections.

Note: Powering up a RAM block takes typically 10 cycles. Thus, it is recommended reading the POWER register before accessing a RAM block that has been recently powered on.

4.3.1 Registers

Instances

Instance	Base address	TrustZone			Split access	Description
		Map	Att	DMA		
VMC : S	0x5003A000					
VMC : NS	0x4003A000	US	NS	NA	No	Volatile memory controller

Register overview

Register	Offset	TZ	Description
RAM[n].POWER	0x600		RAMn power control register
RAM[n].POWERSET	0x604		RAMn power control set register
RAM[n].POWERCLR	0x608		RAMn power control clear register

4.3.1.1 RAM[n].POWER (n=0..7)

Address offset: $0x600 + (n \times 0x10)$

RAMn power control register

Bit number	31	30	29	28	27	26	25	24	23	22	21	20	19	18	17	16	15	14	13	12	11	10	9	8	7	6	5	4	3	2	1	0
ID	H G F E																D C B A															
Reset 0x0000FFFF	0 0 0 0 0 0 0 0 0 0 0 0 0 0 0 0																1 1 1 1 1 1 1 1 1 1 1 1 1 1 1 1															
ID	R/W	Field	Value ID	Value	Description																											
A-D	RW	S[i]POWER (i=0..3)			Keep RAM section Si of RAM n on or off in System ON mode																											
			Off	0	Off																											
			On	1	On																											
E-H	RW	S[i]RETENTION (i=0..3)			Keep retention on RAM section Si of RAM n when RAM section is switched off																											
			Off	0	Off																											
			On	1	On																											

4.3.1.2 RAM[n].POWERSET (n=0..7)

Address offset: 0x604 + (n × 0x10)

RAMn power control set register

When read, this register will return the value of the POWER register.

Bit number	31	30	29	28	27	26	25	24	23	22	21	20	19	18	17	16	15	14	13	12	11	10	9	8	7	6	5	4	3	2	1	0
ID	H G F E																D C B A															
Reset 0x0000FFFF	0 0 0 0 0 0 0 0 0 0 0 0 0 0 0 0																1 1 1 1 1 1 1 1 1 1 1 1 1 1 1 1															
ID	R/W	Field	Value ID	Value	Description																											
A-D	W	S[i]POWER (i=0..3)			Keep RAM section Si of RAM n on or off in System ON mode																											
			On	1	On																											
E-H	W	S[i]RETENTION (i=0..3)			Keep retention on RAM section Si of RAM n when RAM section is switched off																											
			On	1	On																											

4.3.1.3 RAM[n].POWERCLR (n=0..7)

Address offset: 0x608 + (n × 0x10)

RAMn power control clear register

When read, this register will return the value of the POWER register.

Bit number	31	30	29	28	27	26	25	24	23	22	21	20	19	18	17	16	15	14	13	12	11	10	9	8	7	6	5	4	3	2	1	0
ID	H G F E																D C B A															
Reset 0x0000FFFF	0 0 0 0 0 0 0 0 0 0 0 0 0 0 0 0																1 1 1 1 1 1 1 1 1 1 1 1 1 1 1 1															
ID	R/W	Field	Value ID	Value	Description																											
A-D	W	S[i]POWER (i=0..3)			Keep RAM section Si of RAM n on or off in System ON mode																											
			Off	1	Off																											
E-H	W	S[i]RETENTION (i=0..3)			Keep retention on RAM section Si of RAM n when RAM section is switched off																											
			Off	1	Off																											

4.4 NVMC — Non-volatile memory controller

The non-volatile memory controller (NVMC) is used for writing and erasing of the internal flash memory and the user information configuration register (UICR).

The NVMC is a split security peripheral. This means that when the NVMC is configured as non-secure, only a subset of the registers is available from the non-secure code. See [SPU — System protection unit](#) on page 324 and [Registers](#) on page 34 for more details.

When the NVMC is configured to be a secure peripheral, only secure code has access.

Before a write can be performed, the NVMC must be enabled for writing in CONFIG.WEN. Similarly, before an erase can be performed, the NVMC must be enabled for erasing in CONFIG.EEN, see [CONFIG](#) on page 35. The user must make sure that writing and erasing are not enabled at the same time. Failing to do so may result in unpredictable behavior.

4.4.1 Writing to flash

When writing is enabled, in CONFIG register for secure region, or in CONFIGNS register for non-secure region, flash is written by writing a full 32-bit word to a word-aligned address in flash.

Secure code has access to both secure and non-secure regions, by using the appropriate configuration of CONFIG and CONFIGNS registers. Non-secure code, in contrast, has access to non-secure regions only. Thus, non-secure code only needs CONFIGNS.

The NVMC is only able to write '0' to erased bits in flash, that is bits set to '1'. It cannot write a bit back to '1'.

As illustrated in [Memory](#) on page 23, flash is divided into multiple pages. The same address in flash can only be written n_{WRITE} number of times before a page erase must be performed.

Only full 32-bit words can be written to flash using the NVMC interface. To write less than 32 bits to flash, write the data as a word, and set all the bits that should remain unchanged in the word to '1'. Note that the restriction about the number of writes (see above) still applies in this case.

The time it takes to write a word to flash is specified by t_{WRITE} . If CPU executes code from flash while the NVMC is writing to flash, the CPU will be stalled.

Only word-aligned writes are allowed. Byte or half-word-aligned writes will result in a bus fault.

4.4.2 Erasing a secure page in flash

When secure region erase is enabled (in CONFIG register), a flash page can be erased by writing 0xFFFFFFFF into the first 32-bit word in a flash page.

Page erase is only applicable to the code area in the flash and does not work with UICR.

After erasing a flash page, all bits in the page are set to '1'. The time it takes to erase a page is specified by $t_{\text{ERASEPAGE}}$. The CPU is stalled if the CPU executes code from the flash while the NVMC performs the erase operation.

See [Partial erase of a page in flash](#) for information on splitting the erase time in smaller chunks.

4.4.3 Erasing a non-secure page in flash

When non-secure region erase is enabled, a non-secure flash page can be erased by writing 0xFFFFFFFF into the first 32-bit word of the flash page.

Page erase is only applicable to the code area in the flash and does not work with UICR.

After erasing a flash page, all bits in the page are set to '1'. The time it takes to erase a page is specified by $t_{\text{ERASEPAGE}}$. The CPU is stalled if the CPU executes code from the flash while the NVMC performs the erase operation.

4.4.4 Writing to user information configuration registers (UICR)

User information configuration registers (UICR) are written in the same way as flash. After UICR has been written, the new UICR configuration only takes effect after a reset.

UICR is only accessible by secure code. Any write from non-secure code will be faulted.

In order to lock the chip after uploading non-secure code, a simple sequence must be followed:

1. Block access to secure code by setting UICR register [SECUREAPPROTECT](#) on page 46 to protected
2. Use the [WRITEUICRNS](#) on page 37 register, via non-secure debugger, in order to set APPROTECT (APPROTECT is automatically written to 0x00000000 by the NVMC)

UICR can only be written n_{WRITE} number of times before an erase must be performed using [ERASEALL](#).

The time it takes to write a word to the UICR is specified by t_{WRITE} . The CPU is stalled if the CPU executes code from the flash while the NVMC is writing to the UICR.

4.4.5 Erase all

When erase is enabled, the whole flash and UICR can be erased in one operation by using the [ERASEALL](#) register. [ERASEALL](#) does not erase the factory information configuration registers (FICR).

This functionality can be blocked by some configuration of the UICR protection bits, see the table [NVMC protection \(1 - Enabled, 0 - Disabled, X - Don't care\)](#) on page 33.

The time it takes to perform an [ERASEALL](#) on page 35 command is specified by $t_{ERASEALL}$. The CPU is stalled if the CPU executes code from the flash while the NVMC performs the erase operation.

4.4.6 NVMC protection mechanisms

This chapter describes the different protection mechanisms for the non-volatile memory.

4.4.6.1 NVMC blocking

UICR integrity is assured through use of multiple levels of protection. UICR protection bits can be configured to allow or block certain operations.

The table below shows the different statuses of UICR protection bits, and which operations are allowed or blocked.

UICR protection bit status			NVMC protection	
SECUREAPPROTECT	APPROTECT	ERASEPROTECT	CTRL-AP ERASEALL	NVMC ERASEALL
0	0	0	Available	Available
1	X	0	Available	Blocked
X	1	0	Available	Blocked
X	X	1	Blocked	Blocked

Table 7: NVMC protection (1 - Enabled, 0 - Disabled, X - Don't care)

Note: Erase can still be performed through CTRL-AP, regardless of the above settings. See [CTRL-AP - Control access port](#) on page 498 for more information.

Uploading code with secure debugging blocked

Non-secure code can program non-secure flash regions. In order to perform these operations, the NVMC has the following non-secure registers: CONFIGNS, READY and READYNEXT.

Register [CONFIGNS](#) on page 37 works as the CONFIG register but it is used only for non-secure transactions. Both page erase and writing to flash require a write transaction (see [Erasing a secure page in flash](#) on page 32 or [Erasing a non-secure page in flash](#) on page 32). The [SPU — System protection unit](#) on page 324 prevents non-secure code from writing to a secure page since the transaction will never reach the NVMC controller.

4.4.6.2 NVMC power failure protection

NVMC power failure protection is possible using a power-fail comparator which monitors the power supply. If the power-fail comparator is enabled, and the power supply voltage is below V_{POF} threshold, the comparator prevents the NVMC from performing erase or write operations in non-volatile memory (NVM).

If a power failure warning is present at the start of an NVM write or erase operation, the NVMC blocks the operation and a bus error is signaled.

If the power failure warning occurs during an ongoing NVM write operation, the NVMC will try to finish the operation. However, if the power failure warning persists, consecutive NVM write operations are blocked by the NVMC, and a bus error is signaled.

If a power failure warning occurs during an NVM erase operation, the operation is aborted and a bus error is signaled.

4.4.7 Cache

An instruction cache (I-Cache) can be enabled for the ICODE bus in the NVMC.

See [Memory map](#) on page 25 for the location of flash.

A cache hit is an instruction fetch from the cache, and it has a 0 wait-state delay. The number of wait-states for a cache miss, where the instruction is not available in the cache and needs to be fetched from flash, depends on the processor frequency, see CPU parameter `W_FLASHCACHE`.

Enabling the cache can increase the CPU performance and reduce power consumption, by reducing the number of wait cycles and the number of flash accesses. This depends on the cache hit rate. Cache draws current when enabled. If the reduction in average current due to reduced flash accesses is larger than the cache power requirement, the average current to execute the program code is reduced.

When disabled, the cache does not draw current and its content is not retained.

It is possible to enable cache profiling to analyze the performance of the cache for your program using the register `ICACHECNF`. When profiling is enabled, registers `IHIT` and `IMISS` are incremented for every instruction cache hit or miss respectively.

4.4.8 Registers

Instances

Instance	Base address	TrustZone			Split access	Description
		Map	Att	DMA		
NVMC : S	0x50039000					
NVMC : NS	0x40039000	HF	NS	NA	Yes	Non-volatile memory controller

Register overview

Register	Offset	TZ	Description
<code>READY</code>	0x400	NS	Ready flag
<code>READYNEXT</code>	0x408	NS	Ready flag
<code>CONFIG</code>	0x504	S	Configuration register
<code>ERASEALL</code>	0x50C	S	Register for erasing all non-volatile user memory
<code>ERASEPAGEPARTIALCFG</code>	0x51C	S	Register for partial erase configuration
<code>ICACHECNF</code>	0x540	S	I-code cache configuration register
<code>IHIT</code>	0x548	S	I-code cache hit counter
<code>IMISS</code>	0x54C	S	I-code cache miss counter

Register	Offset	TZ	Description
CONFIGNS	0x584	NS	
WRITEUICRNS	0x588	NS	Non-secure APPROTECT enable register

4.4.8.1 READY

Address offset: 0x400

Ready flag

Bit number	31 30 29 28 27 26 25 24 23 22 21 20 19 18 17 16 15 14 13 12 11 10 9 8 7 6 5 4 3 2 1 0																														
ID	A																														
Reset 0x00000001	0 1																														
ID	R/W	TZ	Field	Value ID	Value	Description																									
A	R		READY			NVMC is ready or busy																									
				Busy	0	NVMC is busy (on-going write or erase operation)																									
				Ready	1	NVMC is ready																									

4.4.8.2 READYNEXT

Address offset: 0x408

Ready flag

Bit number	31 30 29 28 27 26 25 24 23 22 21 20 19 18 17 16 15 14 13 12 11 10 9 8 7 6 5 4 3 2 1 0																														
ID	A																														
Reset 0x00000001	0 1																														
ID	R/W	TZ	Field	Value ID	Value	Description																									
A	R		READYNEXT			NVMC can accept a new write operation																									
				Busy	0	NVMC cannot accept any write operation																									
				Ready	1	NVMC is ready																									

4.4.8.3 CONFIG

Address offset: 0x504

Configuration register

Note: This register is one hot

Bit number	31 30 29 28 27 26 25 24 23 22 21 20 19 18 17 16 15 14 13 12 11 10 9 8 7 6 5 4 3 2 1 0																														
ID	A A A																														
Reset 0x00000000	0 0																														
ID	R/W	TZ	Field	Value ID	Value	Description																									
A	RW		WEN			Program memory access mode. It is strongly recommended to only activate erase and write modes when they are actively used.																									
						Enabling write or erase will invalidate the cache and keep it invalidated.																									
				Ren	0	Read only access																									
				Wen	1	Write enabled																									
				Een	2	Erase enabled																									
				PEen	4	Partial erase enabled																									

4.4.8.4 ERASEALL

Address offset: 0x50C

Register for erasing all non-volatile user memory

Bit number	31 30 29 28 27 26 25 24 23 22 21 20 19 18 17 16 15 14 13 12 11 10 9 8 7 6 5 4 3 2 1 0																														
ID	A																														
Reset 0x00000000	0 0																														
ID	R/W	TZ	Field	Value ID	Value	Description																									
A	W		ERASEALL			Erase all non-volatile memory including UICR registers.																									
				NoOperation	0	No operation																									
				Erase	1	Start chip erase																									

Note that erasing must be enabled by setting CONFIG.WEN = Een before the non-volatile memory can be erased.

4.4.8.5 ERASEPAGEPARTIALCFG

Address offset: 0x51C

Register for partial erase configuration

Bit number	31 30 29 28 27 26 25 24 23 22 21 20 19 18 17 16 15 14 13 12 11 10 9 8 7 6 5 4 3 2 1 0																														
ID	A A A A A A A																														
Reset 0x0000000A	0 1 0 1 0																														
ID	R/W	TZ	Field	Value ID	Value	Description																									
A	RW		DURATION			Duration of the partial erase in milliseconds																									
						The user must ensure that the total erase time is long enough for a complete erase of the flash page																									

4.4.8.6 ICACHECNF

Address offset: 0x540

I-code cache configuration register

Bit number	31 30 29 28 27 26 25 24 23 22 21 20 19 18 17 16 15 14 13 12 11 10 9 8 7 6 5 4 3 2 1 0																														
ID	B A																														
Reset 0x00000000	0 0																														
ID	R/W	TZ	Field	Value ID	Value	Description																									
A	RW		CACHEEN			Cache enable																									
				Disabled	0	Disable cache. Invalidates all cache entries.																									
				Enabled	1	Enable cache																									
B	RW		CACHEPROFEN			Cache profiling enable																									
				Disabled	0	Disable cache profiling																									
				Enabled	1	Enable cache profiling																									

4.4.8.7 IHIT

Address offset: 0x548

I-code cache hit counter

Bit number	31	30	29	28	27	26	25	24	23	22	21	20	19	18	17	16	15	14	13	12	11	10	9	8	7	6	5	4	3	2	1	0
ID	A	A	A	A	A	A	A	A	A	A	A	A	A	A	A	A	A	A	A	A	A	A	A	A	A	A	A	A	A	A	A	A
Reset 0x00000000	0	0	0	0	0	0	0	0	0	0	0	0	0	0	0	0	0	0	0	0	0	0	0	0	0	0	0	0	0	0	0	
ID	R/W	TZ	Field	Value ID	Value	Description																										
A	RW		HITS			Number of cache hits																										
						Write zero to clear																										

4.4.8.8 IMISS

Address offset: 0x54C

I-code cache miss counter

Bit number	31	30	29	28	27	26	25	24	23	22	21	20	19	18	17	16	15	14	13	12	11	10	9	8	7	6	5	4	3	2	1	0
ID	A	A	A	A	A	A	A	A	A	A	A	A	A	A	A	A	A	A	A	A	A	A	A	A	A	A	A	A	A	A	A	
Reset 0x00000000	0	0	0	0	0	0	0	0	0	0	0	0	0	0	0	0	0	0	0	0	0	0	0	0	0	0	0	0	0	0	0	
ID	R/W	TZ	Field	Value ID	Value	Description																										
A	RW		MISSES			Number of cache misses																										
						Write zero to clear																										

4.4.8.9 CONFIGNS

Address offset: 0x584

Note: This register is one hot

Bit number	31	30	29	28	27	26	25	24	23	22	21	20	19	18	17	16	15	14	13	12	11	10	9	8	7	6	5	4	3	2	1	0
ID																															A	A
Reset 0x00000000	0	0	0	0	0	0	0	0	0	0	0	0	0	0	0	0	0	0	0	0	0	0	0	0	0	0	0	0	0	0	0	
ID	R/W	TZ	Field	Value ID	Value	Description																										
A	RW		WEN			Program memory access mode. It is strongly recommended to only activate erase and write modes when they are actively used.																										
						Enabling write or erase will invalidate the cache and keep it invalidated.																										
				Ren	0	Read only access																										
				Wen	1	Write enabled																										
				Een	2	Erase enabled																										

4.4.8.10 WRITEUICRNS

Address offset: 0x588

Non-secure APPROTECT enable register

Bit number	31	30	29	28	27	26	25	24	23	22	21	20	19	18	17	16	15	14	13	12	11	10	9	8	7	6	5	4	3	2	1	0
ID	B	B	B	B	B	B	B	B	B	B	B	B	B	B	B	B	B	B	B	B	B	B	B	B	B	B	B	B	B	B	A	
Reset 0x00000000	0	0	0	0	0	0	0	0	0	0	0	0	0	0	0	0	0	0	0	0	0	0	0	0	0	0	0	0	0	0	0	
ID	R/W	TZ	Field	Value ID	Value	Description																										
A	W		SET			Allow non-secure code to set APPROTECT																										
				Set	1	Set value																										
B	W		KEY			Key to write in order to validate the write operation																										
				Keyvalid	0xAFBE5A7	Key value																										

4.4.9 Electrical specification

4.4.9.1 Flash programming

Symbol	Description	Min.	Typ.	Max.	Units
n_{WRITE}	Number of times a 32-bit word can be written before erase			2	
$n_{\text{ENDURANCE}}$	Erase cycles per page	10,000			
t_{WRITE}	Time to write one 32-bit word			43	μs
$t_{\text{ERASEPAGE}}$	Time to erase one page			87	ms
t_{ERASEALL}	Time to erase all flash			173	ms
$t_{\text{ERASEPAGEPARTIAL,setup}}$	Setup time for one partial erase			1.08	ms

4.4.9.2 Cache size

Symbol	Description	Min.	Typ.	Max.	Units
$\text{Size}_{\text{ICODE}}$	I-Code cache size		2048		Bytes

4.5 FICR — Factory information configuration registers

Factory information configuration registers (FICR) are pre-programmed in factory and cannot be erased by the user. These registers contain chip-specific information and configuration.

4.5.1 Registers

Instances

Instance	Base address	TrustZone			Split access	Description
		Map	Att	DMA		
FICR	0x00FF0000	HF	S	NA	No	Factory information configuration

Register overview

Register	Offset	TZ	Description
SIPINFO.PARTNO	0x140		SIP part number
SIPINFO.HWREVISION[n]	0x144		SIP hardware revision, encoded in ASCII, for example B0A or B1A
SIPINFO.VARIANT[n]	0x148		SIP VARIANT, encoded in ASCII, for example SIAA, SIBA or SICA. See Ordering information for details.
INFO.DEVICEID[n]	0x204		Device identifier
INFO.RAM	0x218		RAM variant
INFO.FLASH	0x21C		Flash variant
INFO.CODEPAGESIZE	0x220		Code memory page size
INFO.CODESIZE	0x224		Code memory size
INFO.DEVICETYPE	0x228		Device type
TRIMCNF[n].ADDR	0x300		Address
TRIMCNF[n].DATA	0x304		Data
TRNG90B.BYTES	0xC00		Amount of bytes for the required entropy bits
TRNG90B.RCCUTOFF	0xC04		Repetition counter cutoff
TRNG90B.APCUTOFF	0xC08		Adaptive proportion cutoff
TRNG90B.STARTUP	0xC0C		Amount of bytes for the startup tests

Register	Offset	TZ	Description
TRNG90B.ROSC1	0xC10		Sample count for ring oscillator configuration 1
TRNG90B.ROSC2	0xC14		Sample count for ring oscillator configuration 2
TRNG90B.ROSC3	0xC18		Sample count for ring oscillator configuration 3
TRNG90B.ROSC4	0xC1C		Sample count for ring oscillator configuration 4

4.5.1.1 SIPINFO

SIP-specific device information is provided in the following chapters.

4.5.1.1.1 SIPINFO.PARTNO

Address offset: 0x140

SIP part number

Bit number																																
ID	A A																															
Reset 0xFFFFFFFF	1 1																															
ID	R/W	Field	Value ID	Value	Description																											
A	R	PARTNO																														
			9161	0x00009161	Device is an nRF9161 sip																											
			9160	0x00009160	Device is an nRF9160 sip																											
			9151	0x00009151	Device is an nRF9151 sip																											
			9131	0x00009131	Device is an nRF9131 sip																											

4.5.1.1.2 SIPINFO.HWREVISION[n] (n=0..3)

Address offset: 0x144 + (n × 0x1)

SIP hardware revision, encoded in ASCII, for example B0A or B1A

Note: When treated as a c-string, content is not NULL-terminated

Bit number							
ID	A A A A A A A						
Reset 0xFF	1 1 1 1 1 1 1						
ID	R/W	Field	Value ID	Value	Description		
A	R	HWREVISION					

4.5.1.1.3 SIPINFO.VARIANT[n] (n=0..3)

Address offset: 0x148 + (n × 0x1)

SIP VARIANT, encoded in ASCII, for example SIAA, SIBA or SICA. See [Ordering information](#) for details.

Note: When treated as a c-string, content is not NULL-terminated

Bit number						7	6	5	4	3	2	1	0
ID						A	A	A	A	A	A	A	A
Reset 0xFF						1	1	1	1	1	1	1	1
ID	R/W	Field	Value ID	Value	Description								
A	R	VARIANT			VARIANT[0] contains the most significant character of the SIP VARIANT. VARIANT[3] contains the least significant character of the SIP VARIANT.								
			A	0x41									
			B	0x42									
			C	0x43									
			I	0x49									
			L	0x4C									
			S	0x53									

4.5.1.2 INFO

Device info

4.5.1.2.1 INFO.DEVICEID[n] (n=0..1)

Address offset: 0x204 + (n × 0x4)

Device identifier

Bit number													31	30	29	28	27	26	25	24	23	22	21	20	19	18	17	16	15	14	13	12	11	10	9	8	7	6	5	4	3	2	1	0
ID													A	A	A	A	A	A	A	A	A	A	A	A	A	A	A	A	A	A	A	A	A	A	A	A	A	A	A	A	A	A	A	A
Reset 0xFFFFFFFF													1	1	1	1	1	1	1	1	1	1	1	1	1	1	1	1	1	1	1	1	1	1	1	1	1	1	1	1	1	1	1	1
ID	R/W	Field	Value ID	Value	Description																																							
A	R	DEVICEID			64 bit unique device identifier																																							
					DEVICEID[0] contains the least significant bits of the device identifier. DEVICEID[1] contains the most significant bits of the device identifier.																																							

4.5.1.2.2 INFO.RAM

Address offset: 0x218

RAM variant

Bit number													31	30	29	28	27	26	25	24	23	22	21	20	19	18	17	16	15	14	13	12	11	10	9	8	7	6	5	4	3	2	1	0
ID													A	A	A	A	A	A	A	A	A	A	A	A	A	A	A	A	A	A	A	A	A	A	A	A	A	A	A	A	A	A	A	
Reset 0x00000100													0	0	0	0	0	0	0	0	0	0	0	0	0	0	0	0	0	0	0	0	0	0	0	0	0	0	0	0	0	0	0	0
ID	R/W	Field	Value ID	Value	Description																																							
A	R	RAM			RAM variant																																							
			K256	0x100	256 kByte RAM																																							
			Unspecified	0xFFFFFFFF	Unspecified																																							

4.5.1.2.3 INFO.FLASH

Address offset: 0x21C

Flash variant

Bit number	31	30	29	28	27	26	25	24	23	22	21	20	19	18	17	16	15	14	13	12	11	10	9	8	7	6	5	4	3	2	1	0			
ID	A	A	A	A	A	A	A	A	A	A	A	A	A	A	A	A	A	A	A	A	A	A	A	A	A	A	A	A	A	A	A	A			
Reset	0x00000400																																		
	0	0	0	0	0	0	0	0	0	0	0	0	0	0	0	0	0	0	0	0	0	0	0	0	0	0	0	0	0	0	0	0	0	0	0
ID	R/W	Field	Value ID	Value	Description																														
A	R	FLASH			Flash variant																														
			K1024	0x400	1 MByte FLASH																														

4.5.1.2.4 INFO.CODEPAGESIZE

Address offset: 0x220

Code memory page size

Bit number	31	30	29	28	27	26	25	24	23	22	21	20	19	18	17	16	15	14	13	12	11	10	9	8	7	6	5	4	3	2	1	0		
ID	A	A	A	A	A	A	A	A	A	A	A	A	A	A	A	A	A	A	A	A	A	A	A	A	A	A	A	A	A	A	A	A		
Reset	0x00001000																																	
	0	0	0	0	0	0	0	0	0	0	0	0	0	0	0	0	0	0	0	0	0	0	0	0	0	0	0	0	0	0	0	0	0	0
ID	R/W	Field	Value ID	Value	Description																													
A	R	CODEPAGESIZE			Code memory page size																													
			K4096	0x1000	4 kByte																													

4.5.1.2.5 INFO.CODESIZE

Address offset: 0x224

Code memory size

Bit number	31	30	29	28	27	26	25	24	23	22	21	20	19	18	17	16	15	14	13	12	11	10	9	8	7	6	5	4	3	2	1	0		
ID	A	A	A	A	A	A	A	A	A	A	A	A	A	A	A	A	A	A	A	A	A	A	A	A	A	A	A	A	A	A	A	A		
Reset	0x00000100																																	
	0	0	0	0	0	0	0	0	0	0	0	0	0	0	0	0	0	0	0	0	0	0	0	0	0	0	0	0	0	0	0	0	0	0
ID	R/W	Field	Value ID	Value	Description																													
A	R	CODESIZE			Code memory size in number of pages																													
			P256	256	Total code space is: CODEPAGESIZE * CODESIZE 256 pages																													

4.5.1.2.6 INFO.DEVICETYPE

Address offset: 0x228

Device type

Bit number	31	30	29	28	27	26	25	24	23	22	21	20	19	18	17	16	15	14	13	12	11	10	9	8	7	6	5	4	3	2	1	0	
ID	A	A	A	A	A	A	A	A	A	A	A	A	A	A	A	A	A	A	A	A	A	A	A	A	A	A	A	A	A	A	A	A	
Reset	0xFFFFFFFF																																
	1	1	1	1	1	1	1	1	1	1	1	1	1	1	1	1	1	1	1	1	1	1	1	1	1	1	1	1	1	1	1	1	1
ID	R/W	Field	Value ID	Value	Description																												
A	R	DEVICETYPE			Device type																												
			Die	0x0000000	Device is an physical DIE																												
			FPGA	0xFFFFFFFF	Device is an FPGA																												

4.5.1.3 TRIMCNF[n].ADDR (n=0..255)

Address offset: 0x300 + (n × 0x8)

Address

Bit number	31	30	29	28	27	26	25	24	23	22	21	20	19	18	17	16	15	14	13	12	11	10	9	8	7	6	5	4	3	2	1	0
ID	A	A	A	A	A	A	A	A	A	A	A	A	A	A	A	A	A	A	A	A	A	A	A	A	A	A	A	A	A	A	A	A
Reset 0xFFFFFFFF	1	1	1	1	1	1	1	1	1	1	1	1	1	1	1	1	1	1	1	1	1	1	1	1	1	1	1	1	1	1	1	
ID	R/W	Field	Value ID	Value	Description																											
A	R	Address			Address																											

4.5.1.4 TRIMCNF[n].DATA (n=0..255)

Address offset: 0x304 + (n × 0x8)

Data

Bit number	31	30	29	28	27	26	25	24	23	22	21	20	19	18	17	16	15	14	13	12	11	10	9	8	7	6	5	4	3	2	1	0
ID	A	A	A	A	A	A	A	A	A	A	A	A	A	A	A	A	A	A	A	A	A	A	A	A	A	A	A	A	A	A	A	A
Reset 0xFFFFFFFF	1	1	1	1	1	1	1	1	1	1	1	1	1	1	1	1	1	1	1	1	1	1	1	1	1	1	1	1	1	1	1	
ID	R/W	Field	Value ID	Value	Description																											
A	R	Data			Data																											

4.5.1.5 TRNG90B

NIST800-90B RNG calibration data

4.5.1.5.1 TRNG90B.BYTES

Address offset: 0xC00

Amount of bytes for the required entropy bits

Bit number	31	30	29	28	27	26	25	24	23	22	21	20	19	18	17	16	15	14	13	12	11	10	9	8	7	6	5	4	3	2	1	0
ID	A	A	A	A	A	A	A	A	A	A	A	A	A	A	A	A	A	A	A	A	A	A	A	A	A	A	A	A	A	A	A	A
Reset 0xFFFFFFFF	1	1	1	1	1	1	1	1	1	1	1	1	1	1	1	1	1	1	1	1	1	1	1	1	1	1	1	1	1	1	1	
ID	R/W	Field	Value ID	Value	Description																											
A	R	BYTES			Amount of bytes for the required entropy bits																											

4.5.1.5.2 TRNG90B.RCCUTOFF

Address offset: 0xC04

Repetition counter cutoff

Bit number	31	30	29	28	27	26	25	24	23	22	21	20	19	18	17	16	15	14	13	12	11	10	9	8	7	6	5	4	3	2	1	0
ID	A	A	A	A	A	A	A	A	A	A	A	A	A	A	A	A	A	A	A	A	A	A	A	A	A	A	A	A	A	A	A	
Reset 0xFFFFFFFF	1	1	1	1	1	1	1	1	1	1	1	1	1	1	1	1	1	1	1	1	1	1	1	1	1	1	1	1	1	1	1	
ID	R/W	Field	Value ID	Value	Description																											
A	R	RCCUTOFF			Repetition counter cutoff																											

4.5.1.5.3 TRNG90B.APCUTOFF

Address offset: 0xC08

Adaptive proportion cutoff

Bit number	31	30	29	28	27	26	25	24	23	22	21	20	19	18	17	16	15	14	13	12	11	10	9	8	7	6	5	4	3	2	1	0
ID	A	A	A	A	A	A	A	A	A	A	A	A	A	A	A	A	A	A	A	A	A	A	A	A	A	A	A	A	A	A	A	A
Reset 0xFFFFFFFF	1	1	1	1	1	1	1	1	1	1	1	1	1	1	1	1	1	1	1	1	1	1	1	1	1	1	1	1	1	1	1	
ID	R/W	Field	Value ID	Value	Description																											
A	R	APCUTOFF			Adaptive proportion cutoff																											

4.5.1.5.4 TRNG90B.STARTUP

Address offset: 0xC0C

Amount of bytes for the startup tests

Bit number	31	30	29	28	27	26	25	24	23	22	21	20	19	18	17	16	15	14	13	12	11	10	9	8	7	6	5	4	3	2	1	0
ID	A	A	A	A	A	A	A	A	A	A	A	A	A	A	A	A	A	A	A	A	A	A	A	A	A	A	A	A	A	A	A	
Reset 0xFFFFFFFF	1	1	1	1	1	1	1	1	1	1	1	1	1	1	1	1	1	1	1	1	1	1	1	1	1	1	1	1	1	1	1	
ID	R/W	Field	Value ID	Value	Description																											
A	R	STARTUP			Amount of bytes for the startup tests																											

4.5.1.5.5 TRNG90B.ROSC1

Address offset: 0xC10

Sample count for ring oscillator configuration 1

Bit number	31	30	29	28	27	26	25	24	23	22	21	20	19	18	17	16	15	14	13	12	11	10	9	8	7	6	5	4	3	2	1	0
ID	A	A	A	A	A	A	A	A	A	A	A	A	A	A	A	A	A	A	A	A	A	A	A	A	A	A	A	A	A	A	A	
Reset 0xFFFFFFFF	1	1	1	1	1	1	1	1	1	1	1	1	1	1	1	1	1	1	1	1	1	1	1	1	1	1	1	1	1	1	1	
ID	R/W	Field	Value ID	Value	Description																											
A	R	ROSC1			Sample count for ring oscillator configuration 1																											

4.5.1.5.6 TRNG90B.ROSC2

Address offset: 0xC14

Sample count for ring oscillator configuration 2

Bit number	31	30	29	28	27	26	25	24	23	22	21	20	19	18	17	16	15	14	13	12	11	10	9	8	7	6	5	4	3	2	1	0
ID	A	A	A	A	A	A	A	A	A	A	A	A	A	A	A	A	A	A	A	A	A	A	A	A	A	A	A	A	A	A	A	
Reset 0xFFFFFFFF	1	1	1	1	1	1	1	1	1	1	1	1	1	1	1	1	1	1	1	1	1	1	1	1	1	1	1	1	1	1	1	
ID	R/W	Field	Value ID	Value	Description																											
A	R	ROSC2			Sample count for ring oscillator configuration 2																											

4.5.1.5.7 TRNG90B.ROSC3

Address offset: 0xC18

Sample count for ring oscillator configuration 3

Bit number	31	30	29	28	27	26	25	24	23	22	21	20	19	18	17	16	15	14	13	12	11	10	9	8	7	6	5	4	3	2	1	0
ID	A	A	A	A	A	A	A	A	A	A	A	A	A	A	A	A	A	A	A	A	A	A	A	A	A	A	A	A	A	A	A	
Reset 0xFFFFFFFF	1	1	1	1	1	1	1	1	1	1	1	1	1	1	1	1	1	1	1	1	1	1	1	1	1	1	1	1	1	1	1	
ID	R/W	Field	Value ID	Value	Description																											
A	R	ROSC3			Sample count for ring oscillator configuration 3																											

4.5.1.5.8 TRNG90B.ROSC4

Address offset: 0xC1C

Sample count for ring oscillator configuration 4

Bit number	31	30	29	28	27	26	25	24	23	22	21	20	19	18	17	16	15	14	13	12	11	10	9	8	7	6	5	4	3	2	1	0
ID	A	A	A	A	A	A	A	A	A	A	A	A	A	A	A	A	A	A	A	A	A	A	A	A	A	A	A	A	A	A	A	A
Reset 0xFFFFFFFF	1	1	1	1	1	1	1	1	1	1	1	1	1	1	1	1	1	1	1	1	1	1	1	1	1	1	1	1	1	1	1	
ID	R/W	Field	Value ID	Value	Description																											
A	R	ROSC4			Sample count for ring oscillator configuration 4																											

4.6 UICR — User information configuration registers

The user information configuration registers (UICRs) are non-volatile memory (NVM) registers for configuring user specific settings.

For information on writing UICR registers, see the [NVMC — Non-volatile memory controller](#) on page 31 and [Memory](#) on page 23 chapters.

4.6.1 Registers

Instances

Instance	Base address	TrustZone			Split access	Description
		Map	Att	DMA		
UICR	0x00FF8000	HF	S	NA	No	User information configuration

Register overview

Register	Offset	TZ	Description
APPROTECT	0x000		Access port protection
XOSC32M	0x014		Oscillator control
HFXOSRC	0x01C		HFXO clock source selection
HFXOCNT	0x020		HFXO startup counter
APPNVCMPOFGUARD	0x024		Enable blocking NVM WRITE and aborting NVM ERASE for Application NVM in POFWARN condition.
SECUREAPPROTECT	0x02C		Secure access port protection
ERASEPROTECT	0x030		Erase protection
OTP[n]	0x108		One time programmable memory
KEYSLOT.CONFIG[n].DEST	0x400		Destination address where content of the key value registers (KEYSLOT.KEYn.VALUE[0-3]) will be pushed by KMU. Note that this address must match that of a peripheral's APB mapped write-only key registers, otherwise the KMU can push this key value into an address range which the CPU can potentially read.
KEYSLOT.CONFIG[n].PERM	0x404		Define permissions for the key slot. Bits 0-15 and 16-31 can only be written when equal to 0xFFFF.
KEYSLOT.KEY[n].VALUE[o]	0x800		Define bits $[31+o*32:0+o*32]$ of value assigned to KMU key slot.

4.6.1.1 APPROTECT

Address offset: 0x000

Access port protection

Bit number	31 30 29 28 27 26 25 24 23 22 21 20 19 18 17 16 15 14 13 12 11 10 9 8 7 6 5 4 3 2 1 0																															
ID	A A																															
Reset 0xFFFFFFFF	1 1																															
ID	R/W	Field	Value ID	Value	Description																											
A	RW	PALL			Blocks debugger read/write access to all CPU registers and memory mapped addresses																											
			Unprotected	0xFFFFFFFF	Unprotected																											
			Protected	0x00000000	Protected																											

4.6.1.2 XOSC32M

Address offset: 0x014

Oscillator control

Bit number	31 30 29 28 27 26 25 24 23 22 21 20 19 18 17 16 15 14 13 12 11 10 9 8 7 6 5 4 3 2 1 0																															
ID	A A A A A A																															
Reset 0xFFFFFCF	1 1																															
ID	R/W	Field	Value ID	Value	Description																											
A	RW	CTRL			Pierce current DAC control signals																											

4.6.1.3 HFXOSRC

Address offset: 0x01C

HFXO clock source selection

Bit number	31 30 29 28 27 26 25 24 23 22 21 20 19 18 17 16 15 14 13 12 11 10 9 8 7 6 5 4 3 2 1 0																															
ID	A																															
Reset 0xFFFFFFFF	1 1																															
ID	R/W	Field	Value ID	Value	Description																											
A	RW	HFXOSRC			HFXO clock source selection																											
			XTAL	1	32 MHz crystal oscillator																											
			TCXO	0	32 MHz temperature compensated crystal oscillator (TCXO)																											

4.6.1.4 HFXOCNT

Address offset: 0x020

HFXO startup counter

Bit number	31 30 29 28 27 26 25 24 23 22 21 20 19 18 17 16 15 14 13 12 11 10 9 8 7 6 5 4 3 2 1 0																															
ID	A A A A A A A A																															
Reset 0xFFFFFFFF	1 1																															
ID	R/W	Field	Value ID	Value	Description																											
A	RW	HFXOCNT			HFXO startup counter. Total debounce time = HFXOCNT*64 us + 0.5 us																											
			MinDebounceTime	0	Min debounce time = (0*64 us + 0.5 us)																											
			MaxDebounceTime	255	Max debounce time = (255*64 us + 0.5 us)																											

4.6.1.5 APPNVMCPOFGUARD

Address offset: 0x024

Enable blocking NVM WRITE and aborting NVM ERASE for Application NVM in POFWARN condition.

Bit number	31 30 29 28 27 26 25 24 23 22 21 20 19 18 17 16 15 14 13 12 11 10 9 8 7 6 5 4 3 2 1 0																														
ID	A																														
Reset 0xFFFFFFFF	1 1																														
ID	R/W	Field	Value ID	Value	Description																										
A	RW	NVMCPOFGUARDEN			Enable blocking NVM WRITE and aborting NVM ERASE in POFWARN condition																										
			Disabled	0	NVM WRITE and NVM ERASE are not blocked in POFWARN condition																										
			Enabled	1	NVM WRITE and NVM ERASE are blocked in POFWARN condition																										

4.6.1.6 SECUREAPPROTECT

Address offset: 0x02C

Secure access port protection

Bit number	31 30 29 28 27 26 25 24 23 22 21 20 19 18 17 16 15 14 13 12 11 10 9 8 7 6 5 4 3 2 1 0																														
ID	A A																														
Reset 0xFFFFFFFF	1 1																														
ID	R/W	Field	Value ID	Value	Description																										
A	RW	PALL			Blocks debugger read/write access to all secure CPU registers and secure memory mapped addresses																										
			Unprotected	0xFFFFFFFF	Unprotected																										
			Protected	0x00000000	Protected																										

4.6.1.7 ERASEPROTECT

Address offset: 0x030

Erase protection

Bit number	31 30 29 28 27 26 25 24 23 22 21 20 19 18 17 16 15 14 13 12 11 10 9 8 7 6 5 4 3 2 1 0																														
ID	A A																														
Reset 0xFFFFFFFF	1 1																														
ID	R/W	Field	Value ID	Value	Description																										
A	RW	PALL			Blocks NVMC ERASEALL and CTRLAP ERASEALL functionality																										
			Unprotected	0xFFFFFFFF	Unprotected																										
			Protected	0x00000000	Protected																										

4.6.1.8 OTP[n] (n=0..189)

Address offset: 0x108 + (n × 0x4)

One time programmable memory

Bit number	31	30	29	28	27	26	25	24	23	22	21	20	19	18	17	16	15	14	13	12	11	10	9	8	7	6	5	4	3	2	1	0
ID	B	B	B	B	B	B	B	B	B	B	B	B	B	B	B	A	A	A	A	A	A	A	A	A	A	A	A	A	A	A	A	A
Reset 0xFFFFFFFF	1	1	1	1	1	1	1	1	1	1	1	1	1	1	1	1	1	1	1	1	1	1	1	1	1	1	1	1	1	1	1	

ID	R/W	Field	Value ID	Value	Description
A	RW1	LOWER			Lower half word
Note: Can only be written to a non 0xFFFF value once.					
B	RW1	UPPER			Upper half word
Note: Can only be written to a non 0xFFFF value once.					

4.6.1.9 KEYSLOT.CONFIG[n].DEST (n=0..127)

Address offset: 0x400 + (n × 0x8)

Destination address where content of the key value registers (KEYSLOT.KEYn.VALUE[0-3]) will be pushed by KMU. Note that this address must match that of a peripheral's APB mapped write-only key registers, otherwise the KMU can push this key value into an address range which the CPU can potentially read.

Note: Writing/reading this register requires the KMU SELECTKEYSLOT register to be set to n+1.

Bit number	31	30	29	28	27	26	25	24	23	22	21	20	19	18	17	16	15	14	13	12	11	10	9	8	7	6	5	4	3	2	1	0
ID	A	A	A	A	A	A	A	A	A	A	A	A	A	A	A	A	A	A	A	A	A	A	A	A	A	A	A	A	A	A	A	
Reset 0xFFFFFFFF	1	1	1	1	1	1	1	1	1	1	1	1	1	1	1	1	1	1	1	1	1	1	1	1	1	1	1	1	1	1	1	

ID	R/W	Field	Value ID	Value	Description
A	RW	DEST			Secure APB destination address

4.6.1.10 KEYSLOT.CONFIG[n].PERM (n=0..127)

Address offset: 0x404 + (n × 0x8)

Define permissions for the key slot. Bits 0-15 and 16-31 can only be written when equal to 0xFFFF.

Note: Writing/reading this register requires the KMU SELECTKEYSLOT register to be set to n+1.

Bit number	31	30	29	28	27	26	25	24	23	22	21	20	19	18	17	16	15	14	13	12	11	10	9	8	7	6	5	4	3	2	1	0
ID																									D			C	B	A		
Reset 0xFFFFFFFF	1	1	1	1	1	1	1	1	1	1	1	1	1	1	1	1	1	1	1	1	1	1	1	1	1	1	1	1	1	1	1	1

ID	R/W	Field	Value ID	Value	Description
A	RW	WRITE			Write permission for key slot
			Disabled	0	Disable write to the key value registers
			Enabled	1	Enable write to the key value registers
B	RW	READ			Read permission for key slot
			Disabled	0	Disable read from key value registers
			Enabled	1	Enable read from key value registers
C	RW	PUSH			Push permission for key slot
			Disabled	0	Disable pushing of key value registers over secure APB, but can be read if field READ is Enabled
			Enabled	1	Enable pushing of key value registers over secure APB. Register KEYSLOT.CONFIGn.DEST must contain a valid destination address!

Bit number	31	30	29	28	27	26	25	24	23	22	21	20	19	18	17	16	15	14	13	12	11	10	9	8	7	6	5	4	3	2	1	0
ID	D																C			B	A											
Reset 0xFFFFFFFF	1	1	1	1	1	1	1	1	1	1	1	1	1	1	1	1	1	1	1	1	1	1	1	1	1	1	1	1	1	1	1	
ID	R/W	Field	Value ID	Value	Description																											
D	RW	STATE			Revocation state for the key slot																											
					Note that it is not possible to undo a key revocation by writing the value '1' to this field																											
			Revoked	0	Key value registers can no longer be read or pushed																											
			Active	1	Key value registers are readable (if enabled) and can be pushed (if enabled)																											

4.6.1.11 KEYSLOT.KEY[n].VALUE[o] (n=0..127) (o=0..3)

Address offset: $0x800 + (n \times 0x10) + (o \times 0x4)$

Define bits $[31+o*32:0+o*32]$ of value assigned to KMU key slot.

Note: Writing/reading this register requires the KMU SELECTKEYSLOT register to be set to n+1.

Bit number	31	30	29	28	27	26	25	24	23	22	21	20	19	18	17	16	15	14	13	12	11	10	9	8	7	6	5	4	3	2	1	0
ID	A	A	A	A	A	A	A	A	A	A	A	A	A	A	A	A	A	A	A	A	A	A	A	A	A	A	A	A	A	A	A	
Reset 0xFFFFFFFF	1	1	1	1	1	1	1	1	1	1	1	1	1	1	1	1	1	1	1	1	1	1	1	1	1	1	1	1	1	1	1	
ID	R/W	Field	Value ID	Value	Description																											
A	RW	VALUE			Define bits $[31+o*32:0+o*32]$ of value assigned to KMU key slot																											

4.7 EasyDMA

EasyDMA is a module implemented by some peripherals to gain direct access to Data RAM.

EasyDMA is an AHB bus master similar to CPU and is connected to the AHB multilayer interconnect for direct access to Data RAM. EasyDMA is not able to access flash.

A peripheral can implement multiple EasyDMA instances to provide dedicated channels. For example, for reading and writing of data between the peripheral and RAM. This concept is illustrated in [EasyDMA example](#) on page 48.

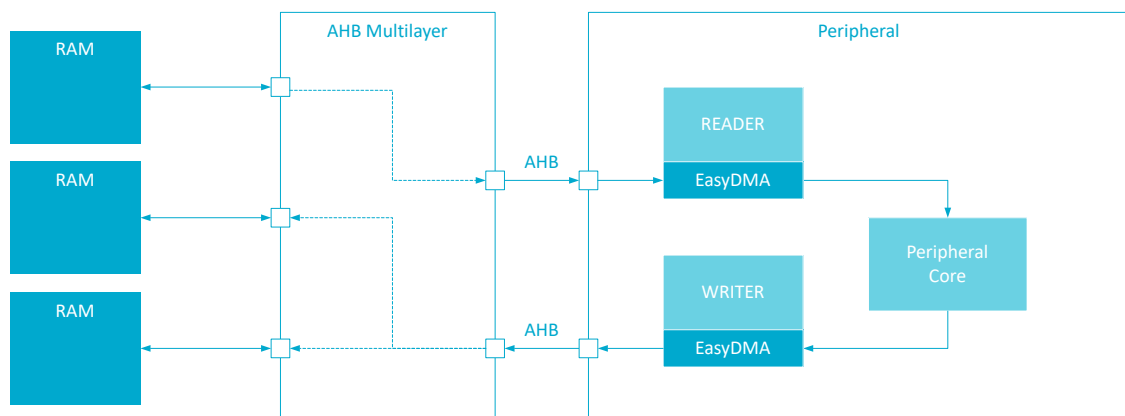

Figure 5: EasyDMA example

An EasyDMA channel is implemented in the following way, but some variations may occur:

```

READERBUFFER_SIZE 5
WRITERBUFFER_SIZE 6

uint8_t readerBuffer[READERBUFFER_SIZE] __at__ 0x20000000;
uint8_t writerBuffer[WRITERBUFFER_SIZE] __at__ 0x20000005;

// Configuring the READER channel
MYPERIPHERAL->READER.MAXCNT = READERBUFFER_SIZE;
MYPERIPHERAL->READER.PTR = &readerBuffer;

// Configure the WRITER channel
MYPERIPHERAL->WRITER.MAXCNT = WRITERBUFFER_SIZE;
MYPERIPHERAL->WRITER.PTR = &writerBuffer;

```

This example shows a peripheral called MYPERIPHERAL that implements two EasyDMA channels - one for reading called READER, and one for writing called WRITER. When the peripheral is started, it is assumed that the peripheral will perform the following tasks:

- Read 5 bytes from the readerBuffer located in RAM at address 0x20000000
- Process the data
- Write no more than 6 bytes back to the writerBuffer located in RAM at address 0x20000005

The memory layout of these buffers is illustrated in [EasyDMA memory layout](#) on page 49.

0x20000000	readerBuffer[0]	readerBuffer[1]	readerBuffer[2]	readerBuffer[3]
0x20000004	readerBuffer[4]	writerBuffer[0]	writerBuffer[1]	writerBuffer[2]
0x20000008	writerBuffer[3]	writerBuffer[4]	writerBuffer[5]	

Figure 6: EasyDMA memory layout

The WRITER.MAXCNT register should not be specified larger than the actual size of the buffer (writerBuffer). Otherwise, the channel would overflow the writerBuffer.

Once an EasyDMA transfer is completed, the AMOUNT register can be read by the CPU to see how many bytes were transferred. For example, CPU can read MYPERIPHERAL->WRITER.AMOUNT register to see how many bytes WRITER wrote to RAM.

Note: The PTR register of a READER or WRITER must point to a valid memory region before use. The reset value of a PTR register is not guaranteed to point to valid memory. See [Memory](#) on page 23 for more information about the different memory regions and EasyDMA connectivity.

4.7.1 EasyDMA error handling

Some errors may occur during DMA handling.

If READER.PTR or WRITER.PTR is not pointing to a valid memory region, an EasyDMA transfer may result in a HardFault or RAM corruption. See [Memory](#) on page 23 for more information about the different memory regions.

If several AHB bus masters try to access the same AHB slave at the same time, AHB bus congestion might occur. An EasyDMA channel is an AHB master. Depending on the peripheral, the peripheral might either stall and wait for access to be granted, or lose data.

4.7.2 EasyDMA array list

EasyDMA can operate in Array List mode.

The Array List mode is implemented in channels where the LIST register is available.

The array list does not provide a mechanism to explicitly specify where the next item in the list is located. Instead, it assumes that the list is organized as a linear array where items are located one after the other in RAM.

The EasyDMA Array List can be implemented by using the data structure `ArrayList_type` as illustrated in the code example below using a `READER` EasyDMA channel as an example:

```
#define BUFFER_SIZE 4

typedef struct ArrayList
{
    uint8_t buffer[BUFFER_SIZE];
} ArrayList_type;

ArrayList_type ReaderList[3] __at__ 0x20000000;

MYPERIPHERAL->READER.MAXCNT = BUFFER_SIZE;
MYPERIPHERAL->READER.PTR = &ReaderList;
MYPERIPHERAL->READER.LIST = MYPERIPHERAL_READER_LIST_ArrayList;
```

The data structure only includes a buffer of size equal to the size of `READER.MAXCNT` register. EasyDMA uses the `READER.MAXCNT` register to determine when the buffer is full.

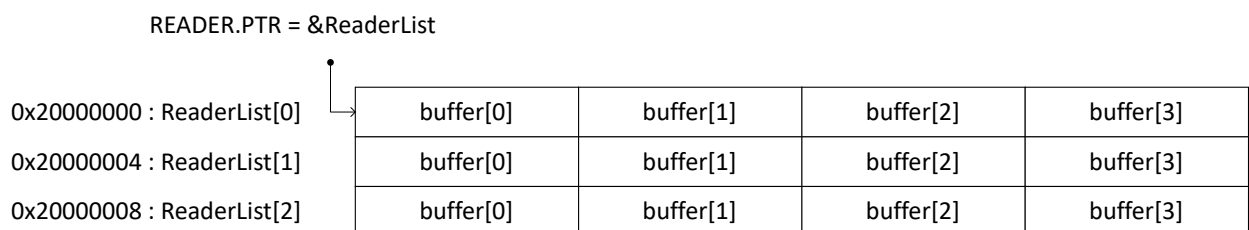

Figure 7: EasyDMA array list

4.8 AHB multilayer interconnect

On the AHB multilayer interconnect, the application CPU and all EasyDMA instances are AHB bus masters while RAM, cache, and peripherals are AHB slaves. External MCU subsystems can be seen both as master and slave on the AHB multilayer interconnect.

Multiple AHB masters can access slave resources within the AHB multilayer interconnect as illustrated in [Memory](#) on page 23. Access rights to each of the AHB slaves are resolved using the default natural priority of the different bus masters in the system.

4.8.1 AHB multilayer priorities

Each master connected to the AHB multilayer is assigned a default natural priority.

Bus master name	Natural relative priority	In/Out
System (CPU)	Highest priority	I/O
LTE Modem		I/O
I2S		I/O
PDM		I
SPIM0/SPIS0/TWIM0/TWIS0/UARTE0		I/O
SPIM1/SPIS1/TWIM1/TWIS1/UARTE1		I/O
SPIM2/SPIS2/TWIM2/TWIS2/UARTE2		I/O
SPIM3/SPIS3/TWIM3/TWIS3/UARTE3		I/O
SAADC		I
PWM0		O
PWM1		O
PWM2		O
PWM3		O
CC310	Lowest priority	I/O

Table 8: AHB bus masters (listed from highest to lowest priority)

5 Power and clock management

The power and clock management system automatically ensures maximum power efficiency.

The nRF9160 has three power modes - System Disabled, System ON and System OFF. The System ON and System OFF are internal (automatically handled by the device) and the System Disabled is external (driven by the ENABLE pin and overriding internal ones).

The core of the automatic power and clock management is the power management unit (PMU) illustrated in the following image.

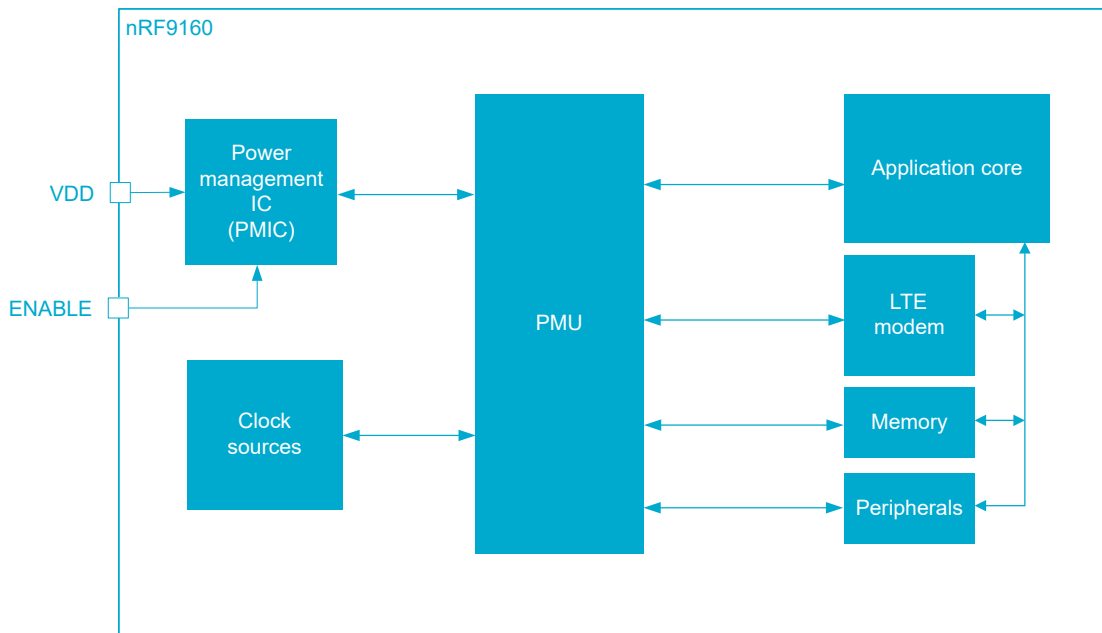

Figure 8: Power management unit

When the device is powered and enabled, the PMU automatically tracks the power and clock resources required by the different components in the system. It then starts/stops and chooses operation modes in supply regulators and clock sources, without user interaction, to achieve the lowest power consumption possible.

5.1 Power management

The two internal modes are handled by the power management unit (PMU), whereas the external is handled by the user via the ENABLE pin.

The System Disabled mode provides a way to override the PMU by manipulating voltages presented to the ENABLE pin.

The PMU steers system-wide clock and power in order to provide the power modes - System ON and System OFF. Under the various modes, internal blocks are automatically powered by the PMU as required by the application.

5.1.1 System Disabled mode

The entire device can be powered down by presenting the appropriate voltage to the externally available ENABLE pin.

The nRF9160 provides a feature to be able to disable power throughout the entire device externally. This can be useful when the device is operating as a slave processor where it does not need to be powered on at all times, then it is possible to avoid unnecessary current leaking by driving the ENABLE pin to low. The nRF9160 will not start if it is not enabled. Moreover, a change from disable to enable, will result in a power-on-reset behavior inside the device.

Note: VDD_GPIO input must be driven low when the device is disabled, failing to do so could result in increased leakage. For more information, see VDD_GPIO considerations in [Operating conditions](#) on page 517.

Note: In case the System Disabled mode is not used, ENABLE must be connected to VDD.

Pin Value	Power status	description
Low	Disabled	Device's internal power regulator disabled
High	Enabled	Device's internal power regulator enabled

Table 9: ENABLE pin configuration

5.1.2 System OFF mode

System OFF is the deepest internal power saving mode the system can enter.

In this mode, the core system functionality is powered down and ongoing tasks terminated, and only the reset and the wakeup functions are available and responsive.

The device is put into System OFF mode using the [REGULATORS](#) register interface. When in System OFF mode, one of the following signals/actions will wake up the device:

1. DETECT signal, generated by the GPIO peripheral
2. RESET
3. Debug session start

When the device wakes up from System OFF mode, a system reset is performed.

One or more RAM blocks can be retained in System OFF mode depending on the settings in the RAM[n].POWER registers in [VMC](#). RAM[n].POWER are retained registers, see [Reset behavior](#) on page 62. Note that these registers are usually overwritten by the startup code provided with the nRF application examples.

Before entering System OFF mode, the user must make sure that all on-going EasyDMA transactions have completed. This can be done by making sure that EasyDMA enabled peripherals have stopped and END events from them received. The LTE modem must also be stopped, by issuing a command through the modem API, before entering System OFF mode. Once the command is issued, wait for the modem to respond that it actually has stopped, as there may be a delay until the modem is disconnected from the network.

5.1.2.1 Emulated System OFF mode

If the device is in debug interface mode, System OFF will be emulated to ensure that all resources required for debugging are available during System OFF.

See [Debug and trace](#) on page 432 chapter for more information. Resources required for debugging include the following key components: [Debug and trace](#) on page 432, [CLOCK — Clock control](#) on page 75, [POWER — Power control](#) on page 69, [NVMC — Non-volatile memory controller](#) on page 31, [CPU](#) on page 22, flash, and RAM. To prevent the CPU from executing unwanted code, an infinite loop must be added directly after entering System OFF mode.

5.1.3 System ON mode

System ON is the power mode entered after a power-on reset.

While in System ON, the system can reside in one of two sub modes:

- Low power
- Constant latency

The low power mode is default after power-on reset.

In low power mode, whenever no application or wireless activity takes place, function blocks like the application CPU, LTE modem and all peripherals are in IDLE state. That particular state is referred to as System ON IDLE. In this state, all function blocks retain their state and configuration, so they are ready to become active once configured by the CPU.

If any application or modem activity occurs, the system leaves the System ON IDLE state. Once a given activity in a function block is completed, the system automatically returns to IDLE, retaining its configuration.

As long as the system resides in low power mode, the PMU ensures that the appropriate regulators and clock sources are started or stopped based on the needs of the function blocks active at any given time.

This automatic power management can be overridden by switching to constant latency mode. In this mode, the CPU wakeup latency and the PPI task response are constant and kept at a minimum. This is secured by keeping a set of base resources that are always enabled. The advantage of having a constant and predictable latency will be at the cost of having significantly increased power consumption compared to the low power mode. The constant latency mode is enabled by triggering the CONSTLAT task ([TASKS_CONSTLAT](#) on page 70).

While the system is in constant latency mode, the low power mode can be enabled by triggering LOWPWR task ([TASKS_LOWPWR](#) on page 70).

To reduce power consumption while in System ON IDLE, RAM blocks can be turned off in System ON mode while enabling the retention of these RAM blocks in RAM[n].POWER registers in [VMC](#). RAM[n].POWER are retained registers, see [Reset behavior](#) on page 62. Note that these registers are usually overwritten by the startup code provided with the nRF application examples.

5.1.4 Electrical specification

5.1.4.1 ENABLE pin

Symbol	Description	Min.	Typ.	Max.	Units
V _{SYSTEM_DISABLED_ON}	Operational voltage to enforce System-Disabled power mode.	0.8*VDD			V
V _{SYSTEM_DISABLED_OFF}	Operational voltage to cancel System-Disabled power mode.			0.4	V

5.2 Power supply

The nRF9160 has a single main power supply VDD, and the internal components are powered by integrated voltage regulators. The PMU manages these regulators automatically, no voltage regulator control needs to be included in application firmware.

5.2.1 General purpose I/O supply

The input/output (I/O) drivers of P0.00 - P0.31 pins are supplied independently of VDD through VDD_GPIO. This enables easy match to signal voltage levels in the printed circuit board design.

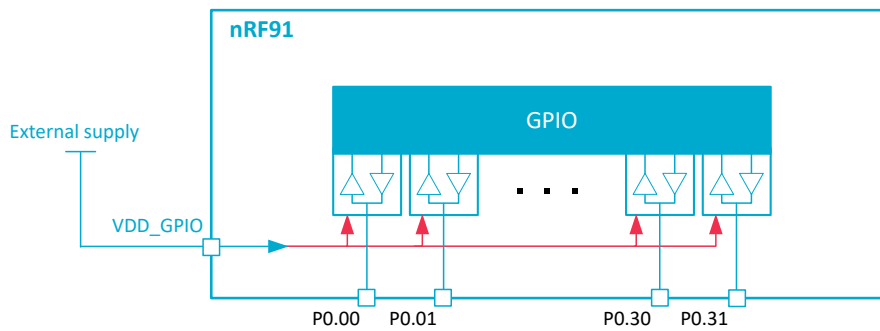

Figure 9: GPIO supply input (VDD_GPIO)

The I/Os are supplied via VDD_GPIO pin as shown in figure above. VDD_GPIO pin supports voltage levels within range given in table [Operating conditions](#) on page 517. See [VDD_GPIO considerations](#) on page 517 for more information on how to control VDD_GPIO power supply.

5.3 Power supply monitoring

Power monitor solutions are available in the device, in order to survey the VDD (battery voltage).

5.3.1 Power supply supervisor

The power supply supervisor enables monitoring of the connected power supply.

Two functionalities are implemented:

- Power-on reset (POR): Generates a reset when the supply is applied to the device, and ensures that the device starts up in a known state
- Brownout reset (BOR): Generates a reset when the supply drops below the minimum voltage required for safe operations

Two BOR levels are used:

- V_{BOROFF} , used in System OFF
- V_{BORON} , used in System ON

The power supply supervisor is illustrated in the image below.

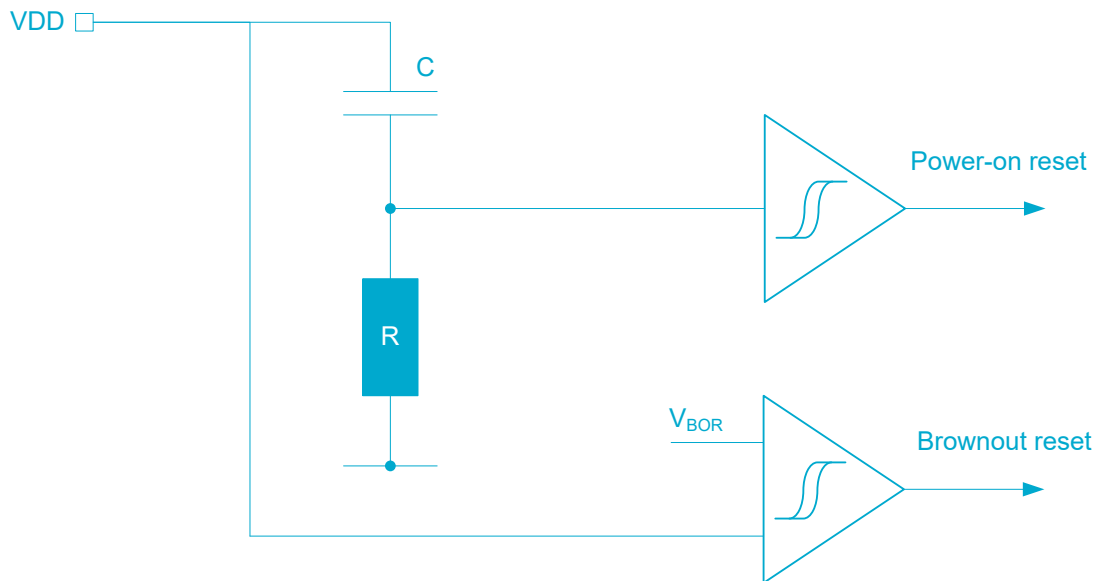

Figure 10: Power supply supervisor

5.3.2 External power failure warning

The external power failure (EXTPOF) warning can provide the CPU an early warning of an imminent power failure. It does not reset the system, but gives the CPU time to prepare for an orderly power-down. EXTPOF detects power failures external to PMU from the device internal PMIC.

Note: This feature is only supported with nRF9160 modem firmware version 1.3.1 and higher.

The user can start and stop the PMIC EXTPOF feature and set the battery voltage low threshold level through the modem API.

For application core to receive the power failure warning events, [EXTPOFCON](#) on page 84 register in [REGULATORS — Voltage regulators control](#) on page 83 must be enabled. If this is disabled, the state of the PMIC warning input is ignored and the power failure warning events are not delivered to application core.

The available time for the CPU to prepare for a power-down depends on the set warning threshold level, the load of the running tasks, and the type of power source used.

Note: For details on services provided by the modem AT command interface, see [nRF Connect SDK AT interface](#) and [nRF91 AT Commands](#).

The EXTPOF functional overview is shown in the following figure.

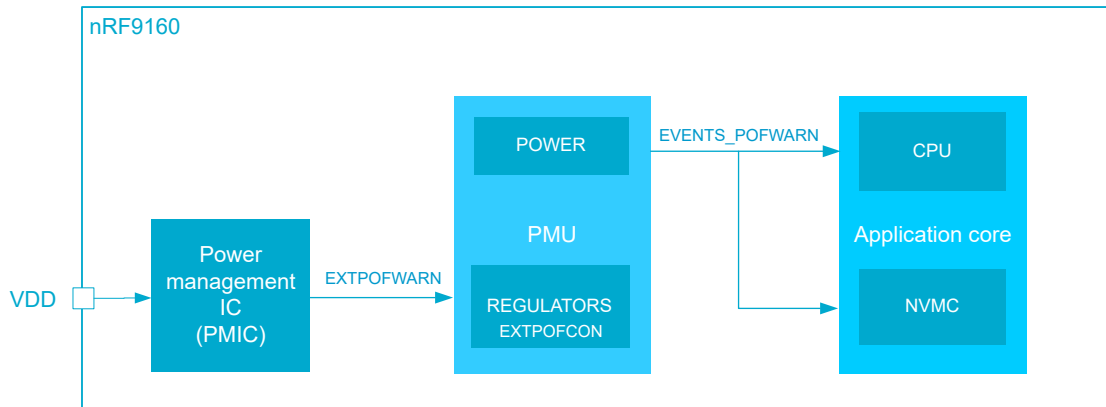

Figure 11: External power failure warning arrangement

If EXTPOF is enabled and the device's internal PMIC detects that battery voltage has dropped below the low threshold level, an POFWARN event is generated (see [EVENTS_POFWARN](#) on page 71). The POFWARN event to the CPU can be cleared in the event register, however the PMIC input continues to indicate a warning as long as the battery voltage remains below the low threshold level.

POFWARN event also sets the LTE modem in offline mode.

Note: If a power failure warning occurs during an ongoing NVM write operation, the NVMC tries to finish the operation. Consecutive NVM write operations will be blocked by the NVMC as long as the PMIC input indicates a warning. The CPU interprets a blocked NVM write as a fault, which needs to be handled by the application. If a power failure warning occurs during an ongoing NVM erase operation, the operation will be aborted. Blocking NVM writes and aborting NVM erase operations can be disabled in [APPNVMCPOFGUARD](#) on page 45.

The external power failure warning doesn't trigger wakeup from System OFF.

The external power failure warning is disabled in System OFF mode.

5.3.3 Battery monitoring on VDD

A battery voltage (VDD) monitoring capability is provided via a modem API.

Note: For details on services provided by the modem AT command interface, see [nRF Connect SDK AT interface](#) and [nRF91 AT Commands](#).

5.3.4 Electrical specification

5.3.4.1 Device startup times

Symbol	Description	Min.	Typ.	Max.	Units
t_{POR}	Time in power-on reset after VDD has reached 3V, ENABLE is tied to VDD.		1.2		ms
t_{PINR}	The maximum time taken to pull up the nRESET pin and release reset after power-on reset. Dependent on the pin capacitive load (C) ² : $t=TRC$; Typical: T=2 R=13 k Ω ; Max: T=5 R=16 k Ω	
$t_{PINR,500nF}$	C=500 nF		13	40	ms

² To decrease the maximum time a device can be held in reset, a strong external pull-up resistor can be used.

Symbol	Description	Min.	Typ.	Max.	Units
t _{PINR,10uF}	C=10 μF		260	800	ms
t _{R2ON}	Time from reset to ON (CPU execute)		127	135	μs
t _{OFF2ON}	Time from OFF to CPU execute		73	92	μs
t _{WFE2CPU}	Time from WFE to CPU execute		70	90	μs
t _{WFI2CPU}	Time from WFI to CPU execute		69	90	μs
t _{EVTSET,CL1}	Time from HW event to PPI event in constant latency System ON mode		0.1	0.1	μs
t _{EVTSET,CLO}	Time from HW event to PPI event in low power System ON mode		0.1	0.7	μs
t _{LTEMODEM,TYP}	LTE modem typical startup time. Time from application core powering up the modem until the modem is ready to receive the first AT command.			200	ms
t _{LTEMODEM,WORSTCASE}	LTE modem worst case startup time. Time from application core powering up the modem until the modem is ready to receive the first AT command, with modem firmware variable elements included.			250	ms
t _{LTEMODEM,FOTA}	LTE modem startup time after modem FOTA update. Time from application core powering up the modem after a modem FOTA update until the modem is ready to receive the first AT command.			7.5	s
t _{LTEMODEM,FOTAREJECT}	LTE modem startup time after a rejected modem FOTA update. Time from application core powering up the modem after a rejected modem FOTA update until the modem is ready to receive the first AT command. Modem will revert back to original firmware image.			90	s
t _{LTEMODEM,STOP,TYP}	LTE modem typical shutdown time. Time from application core calling <code>bsd_shutdown</code> command until <code>bsd_shutdown</code> returns.			1.6	s
t _{LTEMODEM,STOP,WORSTCASE}	LTE modem worst case shutdown time. Time from application core calling <code>bsd_shutdown</code> command until <code>bsd_shutdown</code> returns, including modem firmware variable elements.			79	s

5.3.4.2 Power supply supervisor

Symbol	Description	Min.	Typ.	Max.	Units
V _{BOR}	Brownout reset voltage threshold.		2.80		V
V _{POR}	Voltage threshold at which the device enters power-on reset (POR) when VDD is ramping up.			3.0	V

5.4 Clock management

The clock control system can source the system clocks from a range of high and low frequency oscillators, and distribute them to modules based upon a module's individual requirements.

Clock generation and distribution is handled automatically by PMU to optimize current consumption. This optimization will affect the predictability of the oscillators' startup times under different device operating conditions. However, it is possible to bypass some of the power saving mechanisms by explicitly keeping the system on constant latency sub mode (more about constant latency in [System ON mode](#) on page 54) and/or manipulating START/STOP clock task registers.

The following are the available clock signal sources:

- 64 MHz oscillator (HFINT)
- 64 MHz high accuracy oscillator (HF XO)
- 32.768 kHz RC oscillator (LFRC)
- 32.768 kHz high accuracy oscillator (LF XO)

The clock and oscillator resources are configured and controlled via the CLOCK peripheral as illustrated below.

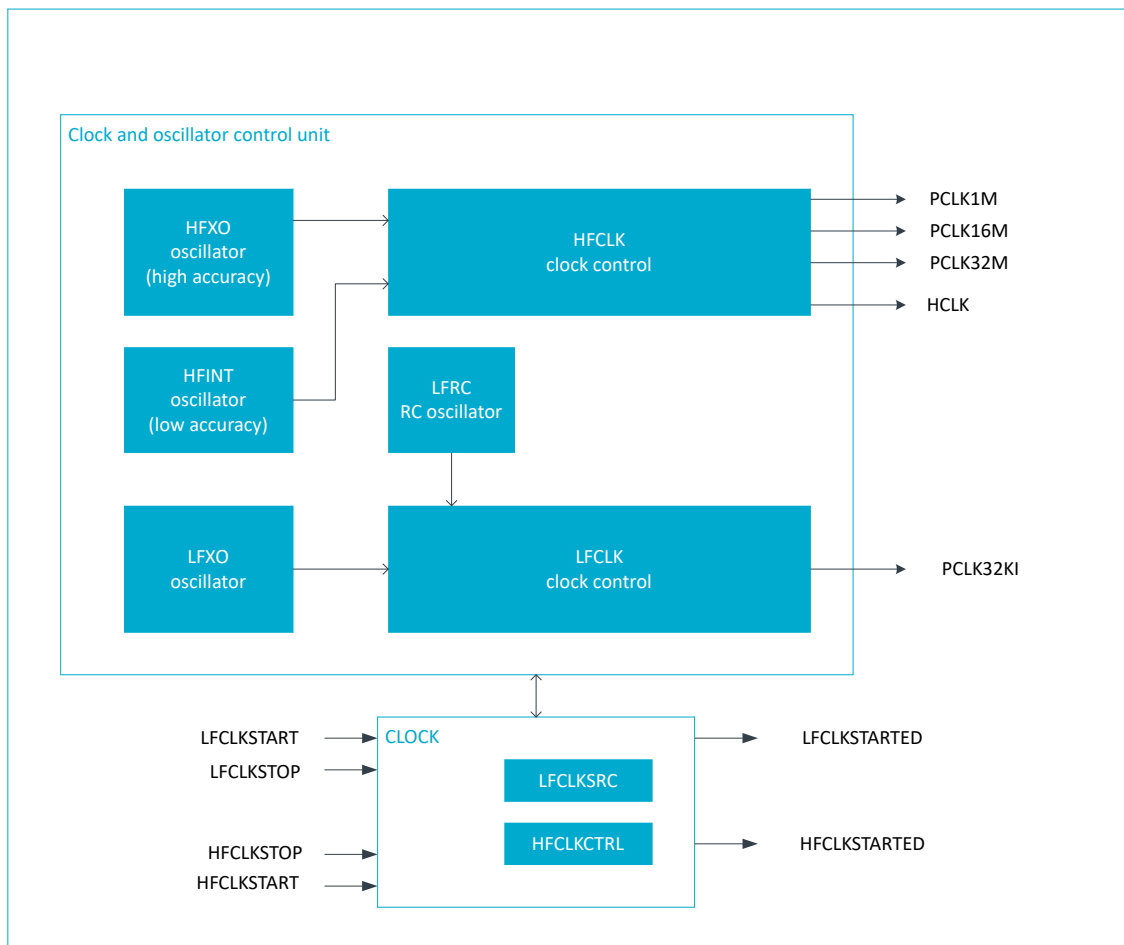

Figure 12: Clock and oscillator setup

5.4.1 HFCLK clock controller

The HFCLK clock controller provides several clocks in the system.

These are as follows:

- HCLK: 64 MHz CPU clock
- PCLK1M: 1 MHz peripheral clock
- PCLK16M: 16 MHz peripheral clock
- PCLK32M: 32 MHz peripheral clock

The HFCLK controller uses the following high frequency clock (HFCLK) sources:

- 64 MHz oscillator (HFINT)
- 64 MHz high accuracy oscillator (HFZO)

For illustration, see [Clock and oscillator setup](#) on page 59.

The HFCLK controller automatically provides the clock(s) requested by the system. If the system does not request any clocks from the HFCLK controller, the controller switches off all its clock sources and enters a power saving mode.

The HFINT source is used when HFCLK is requested and HFZO has not been started.

The HFZO is started by triggering the HFCLKSTART task and stopped using the HFCLKSTOP task. A HFCLKSTARTED event is generated when the HFZO has started and its frequency is stable.

5.4.2 LFCLK clock controller

The system supports several low frequency clock sources.

As illustrated in [Clock and oscillator setup](#) on page 59, the system supports the following low frequency clock sources:

- LFXO: 32.768 kHz high accuracy oscillator
- LFRC: 32.768 kHz RC oscillator

The LFCLK clock controller and all LFCLK clock sources are always switched off when in System OFF mode.

The LFCLK clock is started by first selecting the preferred clock source in the [LFCLKSRC](#) on page 83 register and then triggering the LFCLKSTART task. LFXO is highly recommended as the LFCLK clock source, since the LFRC has a large frequency variation.

Note: The LTE modem requires use of LFXO as the LFCLK source.

Switching between LFCLK clock sources can be done without stopping the LFCLK clock. A LFCLK clock source which is running prior to triggering the LFCLKSTART task continues to run until the selected clock source is available. After that the clock sources will be switched. Switching between clock sources will stretch a clock pulse by 0.5 to 1.0 clock cycle (i.e. will delay rising edge by 0.5 to 1.0 clock cycle).

Note: If the watchdog timer (WDT) is running, the default LFCLK clock source (LFRC - see [LFCLKSRC](#) on page 83) is started automatically (LFCLKSTART task doesn't have to be triggered).

A LFCLKSTARTED event will be generated when the selected LFCLK clock source has started.

Note: The first time LFXO is selected, LFRC quality is provided until LFXO is stable.

A LFCLKSTOP task will prevent global requesting of the LFCLK clock, unless a system component such as WDT or modem requires the LFCLK, in which case the clock is not stopped. The LFCLKSTOP task should only be triggered after the STATE field in the LFCLKSTAT register indicates a LFCLK running state.

5.4.2.1 32.768 kHz RC oscillator (LFRC)

The default source of the low frequency clock (LFCLK) is the 32.768 kHz RC oscillator (LFRC).

The LFRC frequency is affected by variation in temperature.

5.4.3 Electrical specification

5.4.3.1 64 MHz internal oscillator (HFINT)

Symbol	Description	Min.	Typ.	Max.	Units
$f_{\text{NOM_HFINT}}$	Nominal output frequency		64		MHz
$f_{\text{TOL_HFINT}}$	Frequency tolerance		±1	±5	%
$t_{\text{START_HFINT}}$	Startup time		3.2		µs

5.4.3.2 64 MHz high accuracy oscillator (HF XO)

Symbol	Description	Min.	Typ.	Max.	Units
$f_{\text{NOM_HF XO}}$	Nominal output frequency		64		MHz
$f_{\text{TOL_HF XO}}$	Frequency tolerance		±1		ppm
$t_{\text{START_HF XO}}$	Startup time		2		ms

5.4.3.3 32.768 kHz high accuracy oscillator (LFXO)

Symbol	Description	Min.	Typ.	Max.	Units
$f_{\text{NOM_LFXO}}$	Frequency		32.768		kHz
$f_{\text{TOL_LFXO}}$	Frequency tolerance		± 40		ppm
$t_{\text{START_LFXO}}$	Startup time		200		ms

5.4.3.4 32.768 kHz RC oscillator (LFRC)

Symbol	Description	Min.	Typ.	Max.	Units
$f_{\text{NOM_LFRC}}$	Nominal frequency		32.768		kHz
$f_{\text{TOL_LFRC}}$	Frequency tolerance		30		%
$t_{\text{START_LFRC}}$	Startup time		600		μs

5.5 Reset

A system reset can be triggered by multiple sources. After a reset the CPU can query the RESETRAS (reset reason register) to find out which source generated the reset.

5.5.1 Power-on reset

The power-on reset generator initializes the system at power-on. The system is held in reset state until the supply has reached the minimum operating voltage and the internal voltage regulators have started.

5.5.2 Pin reset

A pin reset is generated when the physical reset pin (nRESET) on the device is pulled low.

To ensure that reset is issued correctly, the reset pin should be held low for the time specified in [Pin reset](#) on page 63.

nRESET pin has an always-on internal pull-up resistor connected to nRF9160 internal voltage typically of 2.2 V level, as illustrated in the following figure. The value of the pull-up resistor is given in [Pin reset](#) on page 63.

Note: Driving nRESET high with a voltage lower than 2.2V will result in additional leakage.

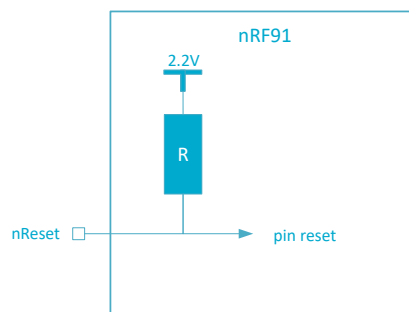

Figure 13: Pin reset internal generation

5.5.3 Wakeup from System OFF mode reset

The device is reset when it wakes up from System OFF mode.

The Debug access port is not reset following a wake up from System OFF mode if the device is in debug interface mode, see [Debug and trace](#) on page 432 chapter for more information.

5.5.4 Soft reset

A soft reset is generated when the SYSRESETREQ bit of the application interrupt and reset control register (AIRCRR register) in the Arm core is set.

5.5.5 Watchdog reset

A watchdog reset is generated when the watchdog timer (WDT) times out.

See [WDT — Watchdog timer](#) on page 418 chapter for more information.

5.5.6 Brownout reset

The brownout reset generator puts the system in reset state if the supply voltage drops below the brownout reset threshold.

5.5.7 Retained registers

A retained register is a register that will retain its value in System OFF mode, and through a reset depending on reset source. For information on which peripheral registers are retained, see the corresponding peripheral's chapter.

5.5.8 Reset behavior

Reset behavior depends on the reset source.

The reset behavior is summarized in the table below.

Reset source	Reset target							
	CPU	Modem	Debug ³	SWJ-DP	Not retained RAM ⁴	Retained RAM ⁴	WDT	RESETREAS
CPU lockup ⁵	x	x						
Soft reset	x	x						
Wakeup from System OFF mode reset	x	x	x ⁶		x		x	
Watchdog reset ⁷	x	x	x		x	x	x	
Pin reset	x	x	x	x	x	x	x	
Brownout reset	x	x	x	x	x	x	x	x
Power-on reset	x	x	x	x	x	x	x	

Table 10: Reset behavior for the main components

Note: The RAM is never reset but its content might be corrupted after reset in the cases given in the table above.

³ All debug components excluding SWJ-DP. See [Debug and trace](#) on page 432 chapter for more information about the different debug components in the system.

⁴ RAM can be configured to be retained using registers in [VMC — Volatile memory controller](#) on page 30

⁵ Reset from CPU lockup is disabled if the device is in debug interface mode. CPU lockup is not possible in System OFF.

⁶ The debug components will not be reset if the device is in debug interface mode.

⁷ Watchdog reset is not available in System OFF.

Reset source	Reset target					
	Regular peripheral registers	GPIO, SPU	NVMC WAITSTATENUM	NVMC IFCREADDELAY	REGULATORS, OSCILLATORS	POWER.GPREGRET
CPU lockup ⁵	x	x	x			
Soft reset	x	x	x			
Wakeup from System OFF mode reset	x		x			
Watchdog reset ⁷	x	x	x		x	
Pin reset	x	x	x		x	
Brownout reset	x	x	x	x	x	x
Power-on reset	x	x	x	x	x	x

Table 11: Reset behavior for the retained registers

5.5.9 Electrical specification

5.5.9.1 Pin reset

Symbol	Description	Min.	Typ.	Max.	Units
t _{HOLDRESET}	Hold time for reset pin when doing a pin reset	5			μs
R _{PULL-UP}	Value of the internal pull-up resistor		13		kΩ

5.6 Current consumption

As the system is constantly tuned by the PMU described in [Power and clock management](#) on page 52, estimating the current consumption of an application can be challenging if the designer cannot perform measurements directly on the hardware. To facilitate the estimation process, a set of current consumption scenarios are provided to show the typical current drawn from the VDD supply.

Each scenario specifies a set of operations and conditions that apply to the given scenario. The following table shows a set of common conditions used in all scenarios, unless otherwise is stated in the scenario's description. Similarly, [Current consumption scenarios, common conditions for LTE modem](#) on page 64 describes the conditions used for the modem current consumption specifications. For a list of all scenarios, see [Electrical specification](#) on page 64.

Peripherals typically share one or more power sources. This results in a current consumption that does not scale linearly with the number of peripherals enabled. For example, the current consumption for an application with two peripherals enabled, is not the sum of the currents reported by their individual peripherals.

Condition	Value
Supply	3.7 V
Temperature	25 °C
CPU	WFI (wait for interrupt)/WFE (wait for event) sleep
Peripherals	All idle ⁸
Clock	HFCLK=HFINT Not running LFCLK=Not running
RAM	No retention
Cache enabled	Yes

Table 12: Current consumption scenarios, common conditions

Condition
Cat-M1 and Cat-NB1 HD FDD mode
Good channel, RF cable, no errors in DL/UL communication
Minimum network response times
Output power at antenna port, single-ended 50 Ω
Modem eDRX current consumption quoted with UICC that allows UICC supply shut down at eDRX intervals. ^{9 10 11}
Modem PSM TAU event energy is measured from the modem PSM wake-up until end of RX inactivity time
All LTE modem current consumption numbers include application core idle mode consumption ¹²

Table 13: Current consumption scenarios, common conditions for LTE modem

5.6.1 Electrical specification

5.6.1.1 Current consumption during System Disabled

Symbol	Description	Min.	Typ.	Max.	Units
I _{SYSTEM_DISABLED}	ENABLE and VDD_GPIO pins grounded		150		nA

⁸ Except for currents reported for a given peripheral. Peripherals' currents are estimated during momentary transmission.

⁹ Required UICC restart current consumption is included.

¹⁰ If the UICC used does not support supply shut down, then UICC will remain in clock stop mode. Depending on the UICC used, a clock stop current in the range of 20 µA to 60 µA@3.7 V must be added to get the total average consumption.

¹¹ Minimum UICC supply shut down interval and clock stop mode current consumption must be obtained from the UICC supplier.

¹² Application RAM leakage not included. Application RAM leakage quoted separately under [Sleep](#) on page 65

5.6.1.2 Sleep

Symbol	Description	Min.	Typ.	Max.	Units
I _{MCUOFF0}	MCU off, modem off, wake on GPIO and reset		1.4		μA
I _{MCUON0}	MCU on IDLE, modem off, RTC off		1.8		μA
I _{MCUON1}	MCU on IDLE, modem off, RTC on		2.2		μA
I _{MCUON2}	MCU on IDLE, modem off, wake on GPIOTE input (event mode), Constant latency System ON mode		600		μA
I _{MCUON3}	MCU on IDLE, modem off, wake on GPIOTE input (event mode), Low power System ON mode		18		μA
I _{MCUON4}	MCU on IDLE, modem off, wake on GPIOTE input (port event)		1.8		μA
I _{RAM}	RAM retention leakage current of a 32kB block		0.1		μA

5.6.1.3 Application CPU active current consumption

The application CPU running parameters are obtained using the following compiler version:

Compiler: Arm version 6.16 (armclang)

Compiler flags:

```
-Wno-unused-command-line-argument --target=arm-arm-none-eabi -c -g -masm=auto -Wno-unused-value -mcpu=cortex-m33 -mfpv=fpv5-sp-d16 -mfloat-abi=hard -fno-rtti -flto -funsigned-char -mcmse -Omax -ffunction-sections
```

Symbol	Description	Min.	Typ.	Max.	Units
I _{CPU0_FLASH}	CPU running CoreMark @64 MHz from flash, clock = HFINT, cache enabled		2.7		mA
I _{COREMARK_PER_MA_FLASH}	CoreMark per mA, executing from flash, CoreMark=247		91		CoreMark/mA
I _{CPU0_RAM}	CPU running CoreMark @64 MHz from RAM, clock = HFINT		2.1		mA
I _{COREMARK_PER_MA_RAM}	CoreMark per mA, executing from RAM, CoreMark=239		114		CoreMark/mA

5.6.1.4 I2S

Symbol	Description	Min.	Typ.	Max.	Units
I _{I2S0}	I2S transferring data left-channel (mono) @ 16 bit x 16 kHz (CONFIG.MCKFREQ = 32MDIV8, CONFIG.RATIO = 256X), Clock = HFINT		0.69		mA
I _{I2S1}	I2S transferring data left-channel (mono) @ 16 bit x 16 kHz (CONFIG.MCKFREQ = 32MDIV8, CONFIG.RATIO = 256X), Clock = HFXO		1.65		mA

5.6.1.5 PDM

Symbol	Description	Min.	Typ.	Max.	Units
I _{PDM}	PDM receiving and processing data 16kHz, with FREQ = 1.28MHz, MODE.OPERATION = mono		0.71		mA
I _{PDM}	PDM receiving and processing data 16kHz, with FREQ = 1.28MHz, MODE.OPERATION = mono, clock HFXO		1.67		mA

5.6.1.6 PWM

Symbol	Description	Min.	Typ.	Max.	Units
I _{PWM0}	PWM running @ 125 kHz, fixed duty cycle		623.97		μA
I _{PWM1}	PWM running @ 16 MHz, fixed duty cycle		723.1		μA

5.6.1.7 SAADC

Symbol	Description	Min.	Typ.	Max.	Units
I _{SAADC_HFXO}	SAADC sampling @ 16 ksps, with high accuracy clock HFXO, acquisition time = 20 μ s		1660		μ A
I _{SAADC_HFINT}	SAADC sampling @ 16 ksps, with low accuracy clock HFINT, acquisition time = 20 μ s		665		μ A

5.6.1.8 TIMER

Symbol	Description	Min.	Typ.	Max.	Units
I _{TIMER0}	TIMER running @ 1 MHz		503.7		μ A
I _{TIMER1}	TIMER running @ 16 MHz		556.3		μ A

5.6.1.9 SPIM

Symbol	Description	Min.	Typ.	Max.	Units
I _{SPIM0}	SPIM transferring data @ 2 Mbps, Clock = HFINT		0.63		mA
I _{SPIM1}	SPIM transferring data @ 2 Mbps, Clock = HFXO		1.58		mA
I _{SPIM2}	SPIM transferring data @ 8 Mbps, Clock = HFINT		0.67		mA
I _{SPIM3}	SPIM transferring data @ 8 Mbps, Clock = HFXO		1.62		mA

5.6.1.10 SPIS

Symbol	Description	Min.	Typ.	Max.	Units
I _{SPIS_2M}	SPIS receiving data @ 2 Mbps, Clock=HFINT		0.63		mA
I _{SPIS_2MXO}	SPIS receiving data @ 2 Mbps, Clock=HFXO		1.58		mA
I _{SPIS_8M}	SPIS receiving data @ 8 Mbps, Clock=HFINT		0.67		mA
I _{SPIS_8MXO}	SPIS receiving data @ 8 Mbps, Clock=HFXO		1.62		mA

5.6.1.11 TWIM

Symbol	Description	Min.	Typ.	Max.	Units
I _{TWIM_100}	TWIM running @ 100 kbps, Clock=HFINT		0.61		mA
I _{TWIM_400}	TWIM running @ 400 kbps, Clock = HFINT		0.61		mA
I _{TWIM_100XO}	TWIM running @ 100 kbps, Clock = HFXO		1.56		mA
I _{TWIM_400XO}	TWIM running @ 400 kbps, Clock = HFXO		1.56		mA

5.6.1.12 TWIS

Symbol	Description	Min.	Typ.	Max.	Units
I _{TWIS_RUN_100}	TWIS transferring data @ 100 kbps, Clock=HFINT		0.60		mA
I _{TWIS1_RUN_400}	TWIS transferring data @ 400 kbps, Clock=HFINT		0.60		mA
I _{TWIS_RUN_100XO}	TWIS transferring data @ 100 kbps, Clock = HFXO		1.55		mA
I _{TWIS_RUN_400XO}	TWIS transferring data @ 400 kbps, Clock = HFXO		1.55		mA

5.6.1.13 UARTe

Symbol	Description	Min.	Typ.	Max.	Units
I _{UARTe,1M}	UARTe transferring data @ 1Mbps		819.2		μA
I _{UARTe,115K}	UARTe transferring data @ 115200 bps		620.6		μA

5.6.1.14 WDT

Symbol	Description	Min.	Typ.	Max.	Units
I _{WDT}	WDT started		2.50		μA

5.6.1.15 Modem current consumption

To estimate specific use cases, see [Online Power Profiler for LTE](#)

Symbol	Description	B13 (typ.)	B20 (typ.)	B3 (typ.)	B4 (typ.)	Units
Sleep current consumption, Cat-M1 and Cat-NB1						
I _{PSM}	PSM floor current	2.7	2.7	2.7	2.7	μA
PSM TAU event energy and duration, Cat-M1						
E _{PSM_TAU}	Pout 23 dBm, QPSK, resource blocks 6, TBS index 9, UICC included	105	-	-	-	mJ
T _{PSM_TAU}	Pout 23 dBm, QPSK, resource blocks 6, TBS index 9, UICC included	1.5	-	-	-	s
PSM TAU event energy and duration, Cat-NB1						
E _{PSM_TAU}	Pout 23 dBm, QPSK, UICC included; UL: 12SC, MCS Index 5 Resource Units 1, Repetitions 1; DL, 12SC, MCS Index 6, Subframes 3, Repetitions 1	550	-	-	-	mJ
T _{PSM_TAU}	Pout 23 dBm, QPSK, UICC included; UL: 12SC, MCS Index 5 Resource Units 1, Repetitions 1; DL, 12SC, MCS Index 6, Subframes 3, Repetitions 1	2.7	-	-	-	s
Average current consumption, radio resource control (RRC) mode, Cat-M1						
I _{EDRX}	eDRX average current, 81.92 s, one PO/PTW, PTW = 2.56 s	18	18	18	18	μA
I _{IEDRX}	Idle eDRX average current, 655 s, one PO/PTW, PTW = 2.56 s	6	6	6	6	μA
I _{RMC_0DBM}	Uplink 180 kbit/s, Pout 0 dBm, RMC settings as per 3GPP TS 36.521-1 Annex A.2	45	45	45	45	mA
I _{RMC_10DBM}	Uplink 180 kbit/s, Pout 10 dBm, RMC settings as per 3GPP TS 36.521-1 Annex A.2	50	50	55	55	mA
I _{RMC_23DBM}	Uplink 180 kbit/s, Pout 23 dBm, RMC settings as per 3GPP TS 36.521-1 Annex A.2	100	105	115	115	mA
Average current consumption, radio resource control (RRC) mode, Cat-NB1						
I _{EDRX}	eDRX average current, 81.92 s, one PO/PTW, PTW = 2.56 s	37	37	37	37	μA
I _{IEDRX}	Idle eDRX average current, 655 s, one PO/PTW, PTW = 2.56 s	9	9	9	9	μA
I _{RMC_0DBM}	Pout 0 dBm, QPSK, 1SC, 15 kHz, TX 33% RX 33% ("balanced TX and RX"), RMC settings as per 3GPP TS 36.101 Annex A.2.4	35	35	40	40	mA
I _{RMC_10DBM}	Pout 10 dBm, QPSK, 1SC, 15 kHz, TX 33% RX 33% ("balanced TX and RX"), RMC settings as per 3GPP TS 36.101 Annex A.2.4	40	45	45	45	mA
I _{RMC_23DBM}	Pout 23 dBm, QPSK, 1SC, 15 kHz, TX 33% RX 33% ("balanced TX and RX"), RMC settings as per 3GPP TS 36.101 Annex A.2.4	95	105	110	110	mA
I _{RMC_0DBM}	Pout 0 dBm, BPSK, 1SC, 3.75 kHz, TX 80% RX 10% ("TX intensive"), RMC settings as per 3GPP TS 36.101 Annex A.2.4	50	50	55	55	mA
I _{RMC_10DBM}	Pout 10 dBm, BPSK, 1SC, 3.75 kHz, TX 80% RX 10% ("TX intensive"), RMC settings as per 3GPP TS 36.101 Annex A.2.4	65	65	75	75	mA
I _{RMC_23DBM}	Pout 23 dBm, BPSK, 1SC, 3.75 kHz, TX 80% RX 10% ("TX intensive"), RMC settings as per 3GPP TS 36.101 Annex A.2.4	190	190	225	225	mA
Peak current consumption, nominal operating conditions, Cat-M1						
I _{TX_0DBM}	TX subframe, Pout 0 dBm	60	60	65	65	mA
I _{TX_10DBM}	TX subframe, Pout 10 dBm	80	85	90	90	mA
I _{TX_23DBM}	TX subframe, Pout 23 dBm	255	275	295	290	mA
I _{RX_90DBM}	RX subframe, Pin -90 dBm	45	45	45	45	mA
I _{TX_TRANSIENT}	TX transient	35	35	35	35	mA/μs
Peak current consumption, nominal operating conditions, Cat-NB1						
I _{TX_0DBM}	TX subframe, Pout 0 dBm	55	60	65	65	mA
I _{TX_10DBM}	TX subframe, Pout 10 dBm	75	85	90	85	mA
I _{TX_23DBM}	TX subframe, Pout 23 dBm	230	255	275	275	mA
I _{RX_90DBM}	RX subframe, Pin -90 dBm	35	35	35	35	mA
I _{TX_TRANSIENT}	TX transient	35	35	35	35	mA/μs
Peak current consumption, extreme operating conditions, Cat-M1						
I _{TX_PEAK}	TX subframe, Pout >21 dBm, Ant VSWR3	330	355	360	360	mA
I _{TX_PEAK}	TX subframe, Pout >20 dBm, Ant VSWR3, Vbat 3.5 V, Temp 85 °C	355	390	375	375	mA
I _{TX_PEAK}	TX subframe, Pout >20 dBm, Ant VSWR3, Vbat 3.0 V, Temp 85 °C	415	415	435	435	mA
Peak current consumption, extreme operating conditions, Cat-NB1						
I _{TX_PEAK}	TX subframe, Pout >21 dBm, Ant VSWR3	280	310	325	325	mA
I _{TX_PEAK}	TX subframe, Pout >20 dBm, Ant VSWR3, Vbat 3.5 V, Temp 85 °C	315	350	365	365	mA
I _{TX_PEAK}	TX subframe, Pout >20 dBm, Ant VSWR3, Vbat 3.0 V, Temp 85 °C	370	405	425	425	mA

5.6.1.16 GPS current consumption

Symbol	Description	Min.	Typ.	Max.	Units
I _{GPS_CONTINUOUS}	Continuous tracking, typical peak current without power saving mode		44.3		mA
I _{GPS_CONTINUOUS_PSM}	Continuous tracking, power saving mode		9.6		mA
I _{GPS_SINGLE}	Single shot, one fix every 2 minutes		2.5		mA

5.7 Register description

5.7.1 POWER — Power control

The POWER module provides an interface to tasks, events, interrupt, and reset related configuration settings of the power management unit.

Note: Registers [INTEN](#) on page 72, [INTENSET](#) on page 73, and [INTENCLR](#) on page 73 are the same registers (at the same address) as corresponding registers in [CLOCK — Clock control](#) on page 75.

5.7.1.1 Registers

Instances

Instance	Base address	TrustZone			Split access	Description
		Map	Att	DMA		
POWER : S	0x50005000					
POWER : NS	0x40005000	US	NS	NA	No	Power control

Register overview

Register	Offset	TZ	Description
TASKS_CONSTLAT	0x78		Enable constant latency mode.
TASKS_LOWPWR	0x7C		Enable low power mode (variable latency)
SUBSCRIBE_CONSTLAT	0xF8		Subscribe configuration for task CONSTLAT
SUBSCRIBE_LOWPWR	0xFC		Subscribe configuration for task LOWPWR
EVENTS_POFWARN	0x108		Power failure warning
EVENTS_SLEEPENTER	0x114		CPU entered WFI/WFE sleep
EVENTS_SLEEPEXIT	0x118		CPU exited WFI/WFE sleep
PUBLISH_POFWARN	0x188		Publish configuration for event POFWARN
PUBLISH_SLEEPENTER	0x194		Publish configuration for event SLEEPENTER
PUBLISH_SLEEPEXIT	0x198		Publish configuration for event SLEEPEXIT
INTEN	0x300		Enable or disable interrupt
INTENSET	0x304		Enable interrupt
INTENCLR	0x308		Disable interrupt
RESETREAS	0x400		Reset reason
POWERSTATUS	0x440		Modem domain power status
GPREGRET[n]	0x51C		General purpose retention register
LTEMODEM.STARTN	0x610		Start LTE modem
LTEMODEM.FORCEOFF	0x614		Force off LTE modem

5.7.1.1.1 TASKS_CONSTLAT

Address offset: 0x78

Enable constant latency mode.

Bit number	31 30 29 28 27 26 25 24 23 22 21 20 19 18 17 16 15 14 13 12 11 10 9 8 7 6 5 4 3 2 1 0																														
ID	A																														
Reset 0x00000000	0 0																														
ID	R/W	Field	Value ID	Value	Description																										
A	W	TASKS_CONSTLAT			Enable constant latency mode.																										
			Trigger	1	Trigger task																										

5.7.1.1.2 TASKS_LOWPWR

Address offset: 0x7C

Enable low power mode (variable latency)

Bit number	31 30 29 28 27 26 25 24 23 22 21 20 19 18 17 16 15 14 13 12 11 10 9 8 7 6 5 4 3 2 1 0																														
ID	A																														
Reset 0x00000000	0 0																														
ID	R/W	Field	Value ID	Value	Description																										
A	W	TASKS_LOWPWR			Enable low power mode (variable latency)																										
			Trigger	1	Trigger task																										

5.7.1.1.3 SUBSCRIBE_CONSTLAT

Address offset: 0xF8

Subscribe configuration for task [CONSTLAT](#)

Bit number	31 30 29 28 27 26 25 24 23 22 21 20 19 18 17 16 15 14 13 12 11 10 9 8 7 6 5 4 3 2 1 0																														
ID	B															A A A A A A A A															
Reset 0x00000000	0 0																														
ID	R/W	Field	Value ID	Value	Description																										
A	RW	CHIDX		[0..255]	DPPI channel that task CONSTLAT will subscribe to																										
B	RW	EN	Disabled	0	Disable subscription																										
			Enabled	1	Enable subscription																										

5.7.1.1.4 SUBSCRIBE_LOWPWR

Address offset: 0xFC

Subscribe configuration for task [LOWPWR](#)

Bit number	31 30 29 28 27 26 25 24 23 22 21 20 19 18 17 16 15 14 13 12 11 10 9 8 7 6 5 4 3 2 1 0																														
ID	B															A A A A A A A A															
Reset 0x00000000	0 0																														
ID	R/W	Field	Value ID	Value	Description																										
A	RW	CHIDX		[0..255]	DPPI channel that task LOWPWR will subscribe to																										
B	RW	EN	Disabled	0	Disable subscription																										
			Enabled	1	Enable subscription																										

5.7.1.1.5 EVENTS_POFWARN

Address offset: 0x108

Power failure warning

Bit number	31	30	29	28	27	26	25	24	23	22	21	20	19	18	17	16	15	14	13	12	11	10	9	8	7	6	5	4	3	2	1	0
ID																																A
Reset 0x00000000	0 0																															
ID	R/W	Field	Value ID	Value	Description																											
A	RW	EVENTS_POFWARN			Power failure warning																											
			NotGenerated	0	Event not generated																											
			Generated	1	Event generated																											

5.7.1.1.6 EVENTS_SLEEPENTER

Address offset: 0x114

CPU entered WFI/WFE sleep

Bit number	31	30	29	28	27	26	25	24	23	22	21	20	19	18	17	16	15	14	13	12	11	10	9	8	7	6	5	4	3	2	1	0
ID																																A
Reset 0x00000000	0 0																															
ID	R/W	Field	Value ID	Value	Description																											
A	RW	EVENTS_SLEEPENTER			CPU entered WFI/WFE sleep																											
			NotGenerated	0	Event not generated																											
			Generated	1	Event generated																											

5.7.1.1.7 EVENTS_SLEEPEXIT

Address offset: 0x118

CPU exited WFI/WFE sleep

Bit number	31	30	29	28	27	26	25	24	23	22	21	20	19	18	17	16	15	14	13	12	11	10	9	8	7	6	5	4	3	2	1	0
ID																																A
Reset 0x00000000	0 0																															
ID	R/W	Field	Value ID	Value	Description																											
A	RW	EVENTS_SLEEPEXIT			CPU exited WFI/WFE sleep																											
			NotGenerated	0	Event not generated																											
			Generated	1	Event generated																											

5.7.1.1.8 PUBLISH_POFWARN

Address offset: 0x188

Publish configuration for event [POFWARN](#)

Bit number	31	30	29	28	27	26	25	24	23	22	21	20	19	18	17	16	15	14	13	12	11	10	9	8	7	6	5	4	3	2	1	0
ID	B																A A A A A A A A															
Reset 0x00000000	0 0																															
ID	R/W	Field	Value ID	Value	Description																											
A	RW	CHIDX		[0..255]	DPPI channel that event POFWARN will publish to																											
B	RW	EN	Disabled	0	Disable publishing																											
			Enabled	1	Enable publishing																											

5.7.1.1.9 PUBLISH_SLEEPENTER

Address offset: 0x194

Publish configuration for event **SLEEPENTER**

Bit number	31	30	29	28	27	26	25	24	23	22	21	20	19	18	17	16	15	14	13	12	11	10	9	8	7	6	5	4	3	2	1	0
ID	B																A A A A A A A A															
Reset 0x00000000	0 0																															
ID	R/W	Field	Value ID	Value	Description																											
A	RW	CHIDX		[0..255]	DPPI channel that event SLEEPENTER will publish to																											
B	RW	EN	Disabled	0	Disable publishing																											
			Enabled	1	Enable publishing																											

5.7.1.1.10 PUBLISH_SLEEPEXIT

Address offset: 0x198

Publish configuration for event **SLEEPEXIT**

Bit number	31	30	29	28	27	26	25	24	23	22	21	20	19	18	17	16	15	14	13	12	11	10	9	8	7	6	5	4	3	2	1	0
ID	B																A A A A A A A A															
Reset 0x00000000	0 0																															
ID	R/W	Field	Value ID	Value	Description																											
A	RW	CHIDX		[0..255]	DPPI channel that event SLEEPEXIT will publish to																											
B	RW	EN	Disabled	0	Disable publishing																											
			Enabled	1	Enable publishing																											

5.7.1.1.11 INTEN

Address offset: 0x300

Enable or disable interrupt

Bit number	31	30	29	28	27	26	25	24	23	22	21	20	19	18	17	16	15	14	13	12	11	10	9	8	7	6	5	4	3	2	1	0
ID																	E D A															
Reset 0x00000000	0 0																															
ID	R/W	Field	Value ID	Value	Description																											
A	RW	POFWARN			Enable or disable interrupt for event POFWARN																											
			Disabled	0	Disable																											
			Enabled	1	Enable																											
D	RW	SLEEPENTER			Enable or disable interrupt for event SLEEPENTER																											
			Disabled	0	Disable																											
			Enabled	1	Enable																											

Bit number	31	30	29	28	27	26	25	24	23	22	21	20	19	18	17	16	15	14	13	12	11	10	9	8	7	6	5	4	3	2	1	0
ID																											E	D	A			
Reset 0x00000000	0	0	0	0	0	0	0	0	0	0	0	0	0	0	0	0	0	0	0	0	0	0	0	0	0	0	0	0	0	0	0	0
ID	R/W	Field	Value ID	Value	Description																											
E	RW	SLEEPEXIT			Enable or disable interrupt for event SLEEPEXIT																											
			Disabled	0	Disable																											
			Enabled	1	Enable																											

5.7.1.1.12 INTENSET

Address offset: 0x304

Enable interrupt

Bit number	31	30	29	28	27	26	25	24	23	22	21	20	19	18	17	16	15	14	13	12	11	10	9	8	7	6	5	4	3	2	1	0
ID																											E	D	A			
Reset 0x00000000	0	0	0	0	0	0	0	0	0	0	0	0	0	0	0	0	0	0	0	0	0	0	0	0	0	0	0	0	0	0	0	
ID	R/W	Field	Value ID	Value	Description																											
A	RW	POFWARN			Write '1' to enable interrupt for event POFWARN																											
			Set	1	Enable																											
			Disabled	0	Read: Disabled																											
			Enabled	1	Read: Enabled																											
D	RW	SLEEPENTER			Write '1' to enable interrupt for event SLEEPENTER																											
			Set	1	Enable																											
			Disabled	0	Read: Disabled																											
			Enabled	1	Read: Enabled																											
E	RW	SLEEPEXIT			Write '1' to enable interrupt for event SLEEPEXIT																											
			Set	1	Enable																											
			Disabled	0	Read: Disabled																											
			Enabled	1	Read: Enabled																											

5.7.1.1.13 INTENCLR

Address offset: 0x308

Disable interrupt

Bit number	31	30	29	28	27	26	25	24	23	22	21	20	19	18	17	16	15	14	13	12	11	10	9	8	7	6	5	4	3	2	1	0
ID																											E	D	A			
Reset 0x00000000	0	0	0	0	0	0	0	0	0	0	0	0	0	0	0	0	0	0	0	0	0	0	0	0	0	0	0	0	0	0	0	
ID	R/W	Field	Value ID	Value	Description																											
A	RW	POFWARN			Write '1' to disable interrupt for event POFWARN																											
			Clear	1	Disable																											
			Disabled	0	Read: Disabled																											
			Enabled	1	Read: Enabled																											
D	RW	SLEEPENTER			Write '1' to disable interrupt for event SLEEPENTER																											
			Clear	1	Disable																											
			Disabled	0	Read: Disabled																											
			Enabled	1	Read: Enabled																											
E	RW	SLEEPEXIT			Write '1' to disable interrupt for event SLEEPEXIT																											
			Clear	1	Disable																											
			Disabled	0	Read: Disabled																											
			Enabled	1	Read: Enabled																											

5.7.1.1.14 RESETREAS

Address offset: 0x400

Reset reason

Note: Unless cleared, the RESETREAS register will be cumulative. A field is cleared by writing '1' to it. If none of the reset sources are flagged, this indicates that the chip was reset from the on-chip reset generator, which will indicate a power-on reset or a brownout reset.

Bit number	31 30 29 28 27 26 25 24 23 22 21 20 19 18 17 16 15 14 13 12 11 10 9 8 7 6 5 4 3 2 1 0																														
ID	G F E																								D C B A						
Reset 0x00000000	0 0																														
ID	R/W	Field	Value ID	Value	Description																										
A	RW	RESETPIN			Reset from pin reset detected																										
			NotDetected	0	Not detected																										
			Detected	1	Detected																										
B	RW	DOG			Reset from global watchdog detected																										
			NotDetected	0	Not detected																										
			Detected	1	Detected																										
C	RW	OFF			Reset due to wakeup from System OFF mode, when wakeup is triggered by DETECT signal from GPIO																										
			NotDetected	0	Not detected																										
			Detected	1	Detected																										
D	RW	DIF			Reset due to wakeup from System OFF mode, when wakeup is triggered by entering debug interface mode																										
			NotDetected	0	Not detected																										
			Detected	1	Detected																										
E	RW	SREQ			Reset from AIRCR.SYSRESETREQ detected																										
			NotDetected	0	Not detected																										
			Detected	1	Detected																										
F	RW	LOCKUP			Reset from CPU lock-up detected																										
			NotDetected	0	Not detected																										
			Detected	1	Detected																										
G	RW	CTRLAP			Reset triggered through CTRL-AP																										
			NotDetected	0	Not detected																										
			Detected	1	Detected																										

5.7.1.1.15 POWERSTATUS

Address offset: 0x440

Modem domain power status

Bit number	31 30 29 28 27 26 25 24 23 22 21 20 19 18 17 16 15 14 13 12 11 10 9 8 7 6 5 4 3 2 1 0																														
ID																															A
Reset 0x00000000	0 0																														
ID	R/W	Field	Value ID	Value	Description																										
A	R	LTEMODEM			LTE modem domain status																										
			OFF	0	LTE modem domain is powered off																										
			ON	1	LTE modem domain is powered on																										

5.7.1.1.16 GPREGRET[n] (n=0..1)

Address offset: 0x51C + (n × 0x4)

General purpose retention register

Bit number	31 30 29 28 27 26 25 24 23 22 21 20 19 18 17 16 15 14 13 12 11 10 9 8 7 6 5 4 3 2 1 0																														
ID	A A A A A A A A																														
Reset 0x00000000	0 0																														
ID	R/W	Field	Value ID	Value	Description																										
A	RW	GPREGRET			General purpose retention register																										
					This register is a retained register																										

5.7.1.1.17 LTEMODEM

LTE Modem

5.7.1.1.17.1 LTEMODEM.STARTN

Address offset: 0x610

Start LTE modem

Note: Starting and stopping LTE modem must only be done through the LTE modem API to guarantee correct sequence in FW and HW and to avoid possible malfunctions.

Bit number	31 30 29 28 27 26 25 24 23 22 21 20 19 18 17 16 15 14 13 12 11 10 9 8 7 6 5 4 3 2 1 0																														
ID	A																														
Reset 0x00000001	0 1																														
ID	R/W	Field	Value ID	Value	Description																										
A	RW	STARTN			Start LTE modem																										
			Start	0	Start LTE modem																										
			Hold	1	Hold LTE modem disabled																										

5.7.1.1.17.2 LTEMODEM.FORCEOFF

Address offset: 0x614

Force off LTE modem

Note: Starting and stopping LTE modem must only be done through the LTE modem API to guarantee correct sequence in FW and HW and to avoid possible malfunctions.

Bit number	31 30 29 28 27 26 25 24 23 22 21 20 19 18 17 16 15 14 13 12 11 10 9 8 7 6 5 4 3 2 1 0																														
ID	A																														
Reset 0x00000000	0 0																														
ID	R/W	Field	Value ID	Value	Description																										
A	RW	FORCEOFF			Force off LTE modem																										
			Release	0	Release force off																										
			Hold	1	Hold force off active																										

5.7.2 CLOCK — Clock control

The CLOCK module provides one of the interfaces to power and clock management configuration settings.

Through CLOCK module it is able to configure the following:

- LFCLK clock source setup
- LFCLK and HFCLK status

- Tasks and events
- Interrupts
- Reset

Note: Registers [INTEN](#) on page 80, [INTENSET](#) on page 80, and [INTENCLR](#) on page 80 are the same registers (at the same address) as corresponding registers in [POWER — Power control](#) on page 69.

5.7.2.1 Registers

Instances

Instance	Base address	TrustZone			Split access	Description
		Map	Att	DMA		
CLOCK : S	0x50005000	US	NS	NA	No	Clock control
CLOCK : NS	0x40005000					

Register overview

Register	Offset	TZ	Description
TASKS_HFCLKSTART	0x000		Start HFCLK source
TASKS_HFCLKSTOP	0x004		Stop HFCLK source
TASKS_LFCLKSTART	0x008		Start LFCLK source
TASKS_LFCLKSTOP	0x00C		Stop LFCLK source
SUBSCRIBE_HFCLKSTART	0x080		Subscribe configuration for task HFCLKSTART
SUBSCRIBE_HFCLKSTOP	0x084		Subscribe configuration for task HFCLKSTOP
SUBSCRIBE_LFCLKSTART	0x088		Subscribe configuration for task LFCLKSTART
SUBSCRIBE_LFCLKSTOP	0x08C		Subscribe configuration for task LFCLKSTOP
EVENTS_HFCLKSTARTED	0x100		HFCLK oscillator started
EVENTS_LFCLKSTARTED	0x104		LFCLK started
PUBLISH_HFCLKSTARTED	0x180		Publish configuration for event HFCLKSTARTED
PUBLISH_LFCLKSTARTED	0x184		Publish configuration for event LFCLKSTARTED
INTEN	0x300		Enable or disable interrupt
INTENSET	0x304		Enable interrupt
INTENCLR	0x308		Disable interrupt
INTPEND	0x30C		Pending interrupts
HFCLKRUN	0x408		Status indicating that HFCLKSTART task has been triggered
HFCLKSTAT	0x40C		The register shows if HFCKO has been requested by triggering HFCLKSTART task and if it has been started (STATE)
LFCLKRUN	0x414		Status indicating that LFCLKSTART task has been triggered
LFCLKSTAT	0x418		The register shows which LFCLK source has been requested (SRC) when triggering LFCLKSTART task and if the source has been started (STATE)
LFCLKSRCCOPY	0x41C		Copy of LFCLKSRC register, set after LFCLKSTART task has been triggered
LFCLKSRC	0x518		Clock source for the LFCLK. LFCLKSTART task starts a clock source selected with this register.

5.7.2.1.1 TASKS_HFCLKSTART

Address offset: 0x000

Start HFCLK source

Bit number	31	30	29	28	27	26	25	24	23	22	21	20	19	18	17	16	15	14	13	12	11	10	9	8	7	6	5	4	3	2	1	0
ID																																A
Reset 0x00000000	0 0																															
ID	R/W	Field	Value ID	Value	Description																											
A	W	TASKS_HFCLKSTART			Start HFCLK source																											
			Trigger	1	Trigger task																											

5.7.2.1.2 TASKS_HFCLKSTOP

Address offset: 0x004

Stop HFCLK source

Bit number	31	30	29	28	27	26	25	24	23	22	21	20	19	18	17	16	15	14	13	12	11	10	9	8	7	6	5	4	3	2	1	0
ID																																A
Reset 0x00000000	0 0																															
ID	R/W	Field	Value ID	Value	Description																											
A	W	TASKS_HFCLKSTOP			Stop HFCLK source																											
			Trigger	1	Trigger task																											

5.7.2.1.3 TASKS_LFCLKSTART

Address offset: 0x008

Start LFCLK source

Bit number	31	30	29	28	27	26	25	24	23	22	21	20	19	18	17	16	15	14	13	12	11	10	9	8	7	6	5	4	3	2	1	0
ID																																A
Reset 0x00000000	0 0																															
ID	R/W	Field	Value ID	Value	Description																											
A	W	TASKS_LFCLKSTART			Start LFCLK source																											
			Trigger	1	Trigger task																											

5.7.2.1.4 TASKS_LFCLKSTOP

Address offset: 0x00C

Stop LFCLK source

Bit number	31	30	29	28	27	26	25	24	23	22	21	20	19	18	17	16	15	14	13	12	11	10	9	8	7	6	5	4	3	2	1	0
ID																																A
Reset 0x00000000	0 0																															
ID	R/W	Field	Value ID	Value	Description																											
A	W	TASKS_LFCLKSTOP			Stop LFCLK source																											
			Trigger	1	Trigger task																											

5.7.2.1.5 SUBSCRIBE_HFCLKSTART

Address offset: 0x080

Subscribe configuration for task [HFCLKSTART](#)

Bit number	31 30 29 28 27 26 25 24 23 22 21 20 19 18 17 16 15 14 13 12 11 10 9 8 7 6 5 4 3 2 1 0																															
ID	B																								A A A A A A A							
Reset	0x00000000																															
	0 0																															
ID	R/W	Field	Value ID	Value	Description																											
A	RW	CHIDX		[0..255]	DPPI channel that task HFCLKSTART will subscribe to																											
B	RW	EN	Disabled	0	Disable subscription																											
			Enabled	1	Enable subscription																											

5.7.2.1.6 SUBSCRIBE_HFCLKSTOP

Address offset: 0x084

Subscribe configuration for task **HFCLKSTOP**

Bit number	31 30 29 28 27 26 25 24 23 22 21 20 19 18 17 16 15 14 13 12 11 10 9 8 7 6 5 4 3 2 1 0																															
ID	B																								A A A A A A A							
Reset	0x00000000																															
	0 0																															
ID	R/W	Field	Value ID	Value	Description																											
A	RW	CHIDX		[0..255]	DPPI channel that task HFCLKSTOP will subscribe to																											
B	RW	EN	Disabled	0	Disable subscription																											
			Enabled	1	Enable subscription																											

5.7.2.1.7 SUBSCRIBE_LFCLKSTART

Address offset: 0x088

Subscribe configuration for task **LFCLKSTART**

Bit number	31 30 29 28 27 26 25 24 23 22 21 20 19 18 17 16 15 14 13 12 11 10 9 8 7 6 5 4 3 2 1 0																															
ID	B																								A A A A A A A							
Reset	0x00000000																															
	0 0																															
ID	R/W	Field	Value ID	Value	Description																											
A	RW	CHIDX		[0..255]	DPPI channel that task LFCLKSTART will subscribe to																											
B	RW	EN	Disabled	0	Disable subscription																											
			Enabled	1	Enable subscription																											

5.7.2.1.8 SUBSCRIBE_LFCLKSTOP

Address offset: 0x08C

Subscribe configuration for task **LFCLKSTOP**

Bit number	31 30 29 28 27 26 25 24 23 22 21 20 19 18 17 16 15 14 13 12 11 10 9 8 7 6 5 4 3 2 1 0																															
ID	B																								A A A A A A A							
Reset	0x00000000																															
	0 0																															
ID	R/W	Field	Value ID	Value	Description																											
A	RW	CHIDX		[0..255]	DPPI channel that task LFCLKSTOP will subscribe to																											
B	RW	EN	Disabled	0	Disable subscription																											
			Enabled	1	Enable subscription																											

5.7.2.1.9 EVENTS_HFCLKSTARTED

Address offset: 0x100

HFCLK oscillator started

Bit number	31	30	29	28	27	26	25	24	23	22	21	20	19	18	17	16	15	14	13	12	11	10	9	8	7	6	5	4	3	2	1	0
ID																																A
Reset 0x00000000	0 0																															
ID	R/W	Field	Value ID	Value	Description																											
A	RW	EVENTS_HFCLKSTARTED			HFCLK oscillator started																											
			NotGenerated	0	Event not generated																											
			Generated	1	Event generated																											

5.7.2.1.10 EVENTS_LFCLKSTARTED

Address offset: 0x104

LFCLK started

Bit number	31	30	29	28	27	26	25	24	23	22	21	20	19	18	17	16	15	14	13	12	11	10	9	8	7	6	5	4	3	2	1	0
ID																																A
Reset 0x00000000	0 0																															
ID	R/W	Field	Value ID	Value	Description																											
A	RW	EVENTS_LFCLKSTARTED			LFCLK started																											
			NotGenerated	0	Event not generated																											
			Generated	1	Event generated																											

5.7.2.1.11 PUBLISH_HFCLKSTARTED

Address offset: 0x180

Publish configuration for event [HFCLKSTARTED](#)

Bit number	31	30	29	28	27	26	25	24	23	22	21	20	19	18	17	16	15	14	13	12	11	10	9	8	7	6	5	4	3	2	1	0		
ID																B											A	A	A	A	A	A	A	A
Reset 0x00000000	0 0																																	
ID	R/W	Field	Value ID	Value	Description																													
A	RW	CHIDX		[0..255]	DPPI channel that event HFCLKSTARTED will publish to																													
B	RW	EN																																
			Disabled	0	Disable publishing																													
			Enabled	1	Enable publishing																													

5.7.2.1.12 PUBLISH_LFCLKSTARTED

Address offset: 0x184

Publish configuration for event [LFCLKSTARTED](#)

Bit number	31	30	29	28	27	26	25	24	23	22	21	20	19	18	17	16	15	14	13	12	11	10	9	8	7	6	5	4	3	2	1	0												
ID	B																							A				A	A	A	A	A	A	A										
Reset	0x00000000																																											
Reset	0 0																																											
ID	R/W	Field	Value ID	Value	Description																																							
A	RW	CHIDX		[0..255]	DPPI channel that event LFCLKSTARTED will publish to																																							
B	RW	EN	Disabled	0	Disable publishing																																							
			Enabled	1	Enable publishing																																							

5.7.2.1.13 INTEN

Address offset: 0x300

Enable or disable interrupt

Bit number	31	30	29	28	27	26	25	24	23	22	21	20	19	18	17	16	15	14	13	12	11	10	9	8	7	6	5	4	3	2	1	0	
ID																														B	A		
Reset	0x00000000																																
Reset	0 0																																
ID	R/W	Field	Value ID	Value	Description																												
A	RW	HFCLKSTARTED	Disabled	0	Enable or disable interrupt for event HFCLKSTARTED																												
			Enabled	1	Disable																												
			Enabled	1	Enable																												
B	RW	LFCLKSTARTED	Disabled	0	Enable or disable interrupt for event LFCLKSTARTED																												
			Enabled	1	Disable																												
			Enabled	1	Enable																												

5.7.2.1.14 INTENSET

Address offset: 0x304

Enable interrupt

Bit number	31	30	29	28	27	26	25	24	23	22	21	20	19	18	17	16	15	14	13	12	11	10	9	8	7	6	5	4	3	2	1	0	
ID																														B	A		
Reset	0x00000000																																
Reset	0 0																																
ID	R/W	Field	Value ID	Value	Description																												
A	RW	HFCLKSTARTED	Set	1	Write '1' to enable interrupt for event HFCLKSTARTED																												
			Disabled	0	Enable																												
			Enabled	1	Read: Disabled																												
			Enabled	1	Read: Enabled																												
B	RW	LFCLKSTARTED	Set	1	Write '1' to enable interrupt for event LFCLKSTARTED																												
			Disabled	0	Enable																												
			Enabled	1	Read: Disabled																												
			Enabled	1	Read: Enabled																												

5.7.2.1.15 INTENCLR

Address offset: 0x308

Disable interrupt

Bit number	31 30 29 28 27 26 25 24 23 22 21 20 19 18 17 16 15 14 13 12 11 10 9 8 7 6 5 4 3 2 1 0																															
ID																															B	A
Reset 0x00000000	0 0																															
ID	R/W	Field	Value ID	Value	Description																											
A	RW	HFCLKSTARTED			Write '1' to disable interrupt for event HFCLKSTARTED																											
			Clear	1	Disable																											
			Disabled	0	Read: Disabled																											
			Enabled	1	Read: Enabled																											
B	RW	LFCLKSTARTED			Write '1' to disable interrupt for event LFCLKSTARTED																											
			Clear	1	Disable																											
			Disabled	0	Read: Disabled																											
			Enabled	1	Read: Enabled																											

5.7.2.1.16 INTPEND

Address offset: 0x30C

Pending interrupts

Bit number	31 30 29 28 27 26 25 24 23 22 21 20 19 18 17 16 15 14 13 12 11 10 9 8 7 6 5 4 3 2 1 0																															
ID																															B	A
Reset 0x00000000	0 0																															
ID	R/W	Field	Value ID	Value	Description																											
A	R	HFCLKSTARTED			Read pending status of interrupt for event HFCLKSTARTED																											
			NotPending	0	Read: Not pending																											
			Pending	1	Read: Pending																											
B	R	LFCLKSTARTED			Read pending status of interrupt for event LFCLKSTARTED																											
			NotPending	0	Read: Not pending																											
			Pending	1	Read: Pending																											

5.7.2.1.17 HFCLKRUN

Address offset: 0x408

Status indicating that HFCLKSTART task has been triggered

Bit number	31 30 29 28 27 26 25 24 23 22 21 20 19 18 17 16 15 14 13 12 11 10 9 8 7 6 5 4 3 2 1 0																														
ID																															A
Reset 0x00000000	0 0																														
ID	R/W	Field	Value ID	Value	Description																										
A	R	STATUS			HFCLKSTART task triggered or not																										
			NotTriggered	0	Task not triggered																										
			Triggered	1	Task triggered																										

5.7.2.1.18 HFCLKSTAT

Address offset: 0x40C

The register shows if HFXO has been requested by triggering HFCLKSTART task and if it has been started (STATE)

Bit number	31 30 29 28 27 26 25 24 23 22 21 20 19 18 17 16 15 14 13 12 11 10 9 8 7 6 5 4 3 2 1 0																																
ID	B																														A		
Reset	0x00000000																																
0	0	0	0	0	0	0	0	0	0	0	0	0	0	0	0	0	0	0	0	0	0	0	0	0	0	0	0	0	0	0	0	0	0
ID	R/W	Field	Value ID	Value	Description																												
A	R	SRC			Active clock source																												
			HFINT	0	HFINT - 64 MHz on-chip oscillator																												
			HFXO	1	HFXO - 64 MHz clock derived from external 32 MHz crystal oscillator																												
B	R	STATE			HFCLK state																												
			NotRunning	0	HFXO has not been started or HFCLKSTOP task has been triggered																												
			Running	1	HFXO has been started (HFCLKSTARTED event has been generated)																												

5.7.2.1.19 LFCLKRUN

Address offset: 0x414

Status indicating that LFCLKSTART task has been triggered

Bit number	31 30 29 28 27 26 25 24 23 22 21 20 19 18 17 16 15 14 13 12 11 10 9 8 7 6 5 4 3 2 1 0																															
ID																															A	
Reset	0x00000000																															
0	0	0	0	0	0	0	0	0	0	0	0	0	0	0	0	0	0	0	0	0	0	0	0	0	0	0	0	0	0	0	0	0
ID	R/W	Field	Value ID	Value	Description																											
A	R	STATUS			LFCLKSTART task triggered or not																											
			NotTriggered	0	Task not triggered																											
			Triggered	1	Task triggered																											

5.7.2.1.20 LFCLKSTAT

Address offset: 0x418

The register shows which LFCLK source has been requested (SRC) when triggering LFCLKSTART task and if the source has been started (STATE)

Bit number	31 30 29 28 27 26 25 24 23 22 21 20 19 18 17 16 15 14 13 12 11 10 9 8 7 6 5 4 3 2 1 0																															
ID	B																														A	A
Reset	0x00000000																															
0	0	0	0	0	0	0	0	0	0	0	0	0	0	0	0	0	0	0	0	0	0	0	0	0	0	0	0	0	0	0	0	0
ID	R/W	Field	Value ID	Value	Description																											
A	R	SRC			Active clock source																											
			RFU	0	Reserved for future use																											
			LFRC	1	32.768 kHz RC oscillator																											
			LFXO	2	32.768 kHz crystal oscillator																											
B	R	STATE			LFCLK state																											
			NotRunning	0	Requested LFCLK source has not been started or LFCLKSTOP task has been triggered																											
			Running	1	Requested LFCLK source has been started (LFCLKSTARTED event has been generated)																											

5.7.2.1.21 LFCLKSRCCOPY

Address offset: 0x41C

Copy of LFCLKSRC register, set after LFCLKSTART task has been triggered

Bit number	31	30	29	28	27	26	25	24	23	22	21	20	19	18	17	16	15	14	13	12	11	10	9	8	7	6	5	4	3	2	1	0	
ID																																A	A
Reset 0x00000001	0 1																																
ID	R/W	Field	Value ID	Value	Description																												
A	R	SRC			Clock source																												
			RFU	0	Reserved for future use																												
			LFRC	1	32.768 kHz RC oscillator																												
			LFXO	2	32.768 kHz crystal oscillator																												

5.7.2.1.22 LFCLKSRC

Address offset: 0x518

Clock source for the LFCLK. LFCLKSTART task starts a clock source selected with this register.

Bit number	31	30	29	28	27	26	25	24	23	22	21	20	19	18	17	16	15	14	13	12	11	10	9	8	7	6	5	4	3	2	1	0	
ID																																A	A
Reset 0x00000001	0 1																																
ID	R/W	Field	Value ID	Value	Description																												
A	RW	SRC			Clock source																												
			RFU	0	Reserved for future use (equals selecting LFRC)																												
			LFRC	1	32.768 kHz RC oscillator																												
			LFXO	2	32.768 kHz crystal oscillator																												

5.7.3 REGULATORS — Voltage regulators control

The REGULATORS module provides an interface to certain configuration settings of on-chip voltage regulators.

5.7.3.1 Registers

Instances

Instance	Base address	TrustZone			Split access	Description
		Map	Att	DMA		
REGULATORS : S	0x50004000					
REGULATORS : NS	0x40004000	US	NS	NA	No	Regulator configuration

Register overview

Register	Offset	TZ	Description
SYSTEMOFF	0x500		System OFF register
EXTPOFCON	0x514		External power failure warning configuration
DCDCEN	0x578		Enable a step-down DC/DC voltage regulator

5.7.3.1.1 SYSTEMOFF

Address offset: 0x500

System OFF register

Bit number	31	30	29	28	27	26	25	24	23	22	21	20	19	18	17	16	15	14	13	12	11	10	9	8	7	6	5	4	3	2	1	0
ID																																A
Reset 0x00000000	0 0																															
ID	R/W	Field	Value ID	Value	Description																											
A	W	SYSTEMOFF			Enable System OFF mode																											
			Enable	1	Enable System OFF mode																											

5.7.3.1.2 EXTPOFCON

Address offset: 0x514

External power failure warning configuration

Bit number	31	30	29	28	27	26	25	24	23	22	21	20	19	18	17	16	15	14	13	12	11	10	9	8	7	6	5	4	3	2	1	0
ID																																A
Reset 0x00000000	0 0																															
ID	R/W	Field	Value ID	Value	Description																											
A	RW	POF			Enable or disable external power failure warning																											
			Disabled	0	Disable																											
			Enabled	1	Enable																											

5.7.3.1.3 DCDCEN

Address offset: 0x578

Enable a step-down DC/DC voltage regulator

Note: DCDCEN must be set to 1 (enabled) before the LTE modem is started.

Bit number	31	30	29	28	27	26	25	24	23	22	21	20	19	18	17	16	15	14	13	12	11	10	9	8	7	6	5	4	3	2	1	0
ID																																A
Reset 0x00000000	0 0																															
ID	R/W	Field	Value ID	Value	Description																											
A	RW	DCDCEN			Enable DC/DC buck regulator																											
			Disabled	0	DC/DC buck regulator is disabled																											
			Enabled	1	DC/DC buck regulator is enabled																											

6 Peripherals

The nRF9160 application core peripherals are found in [Instantiation](#) on page 27.

6.1 CRYPTOCELL — Arm TrustZone CryptoCell 310

Arm TrustZone CryptoCell 310 (CRYPTOCELL) is a security subsystem providing root of trust (RoT) and cryptographic services for a device.

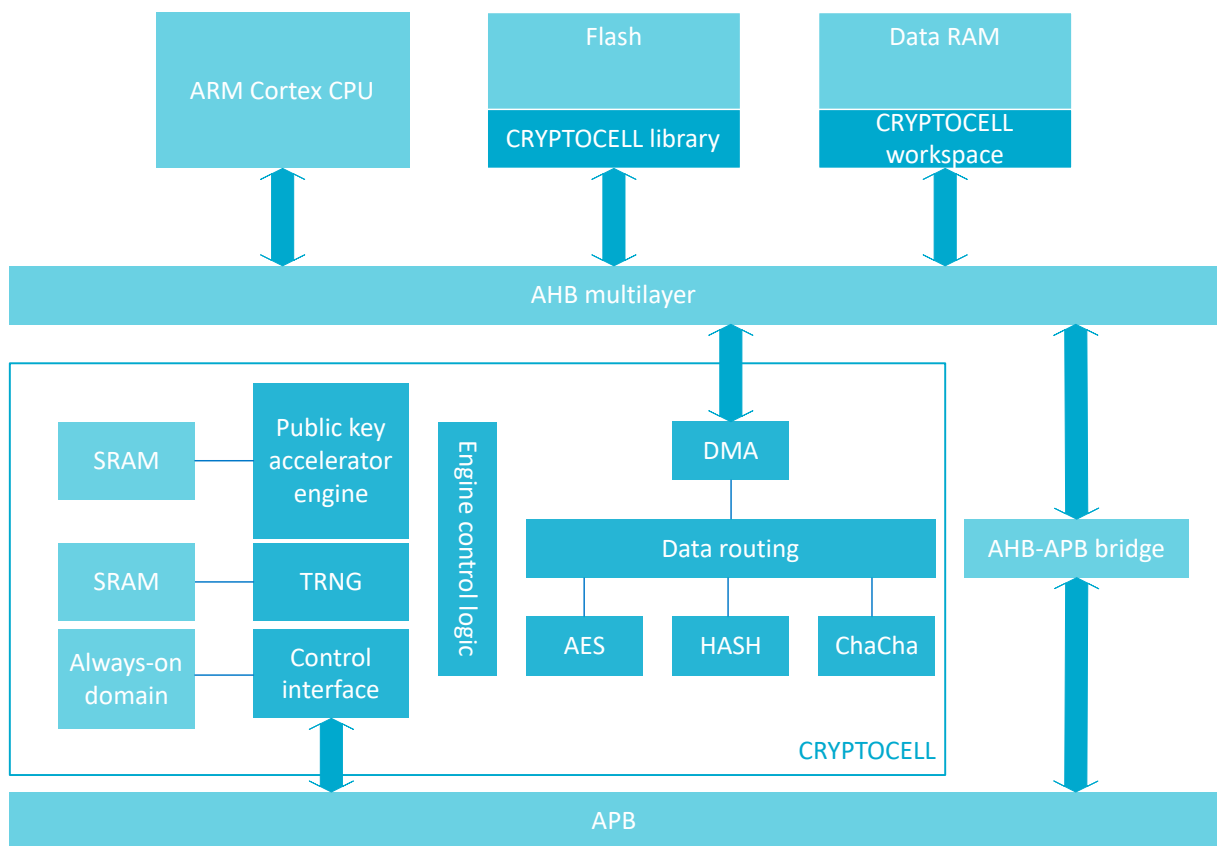

Figure 14: CRYPTOCELL block diagram

The following cryptographic features are among the functionality that can be supported:

- True random number generator (TRNG) compliant with FIPS 140-2, BIS AIS-31, and NIST 800-90B.
- Pseudorandom number generator (PRNG) using underlying AES engine compliant with NIST 800-90A
- RSA public key cryptography
 - Signature verification up to key sizes of 2048 bits
 - Key generation up to key sizes of 2048 bits
 - PKCS#1 v2.1/v1.5
- Elliptic curve cryptography (ECC)
 - NIST FIPS 186-4 recommended curves using pseudorandom parameters, up to 521 bits:
 - Prime field: P-192, P-224, P-256, P-384, P-521
 - SEC 2 recommended curves using pseudorandom parameters, up to 521 bits:
 - Prime field: secp160r1, secp192r1, secp224r1, secp256r1, secp384r1, secp521r1

- Koblitz curves using fixed parameters, up to 256 bits:
 - Prime field: secp160k1, secp192k1, secp224k1, secp256k1
- Brainpool curves:
 - Prime field: BrainpoolP256r1
- Edwards/Montgomery curves:
 - Ed25519, Curve25519
- ECDH/ECDSA support
- Secure remote password protocol (SRP), up to 3072 bits operations
- Hashing functions
 - SHA-1, SHA-2 up to 256 bits
 - Keyed-hash message authentication code (HMAC)
- AES symmetric encryption
 - General purpose AES engine (encrypt/decrypt, sign/verify)
 - 128 bits key size
 - Supported encryption modes: ECB, CBC, CMAC/CBC-MAC, CTR, CCM/CCM*
- ChaCha20/Poly1305 symmetric encryption
 - 128 and 256 bits key size
 - Authenticated encryption with associated data (AEAD) mode

6.1.1 Disclaimer

This section contains an important disclaimer about the CRYPTOCELL subsystem documentation.

The CRYPTOCELL subsystem is recommended for use with the libraries in the Nordic Semiconductor ASA SDK. These libraries are tested and verified to work with the CRYPTOCELL subsystem hardware. The CRYPTOCELL subsystem documentation and register descriptions are for reference only and can be used for modifying the Nordic supplied SDK libraries or implementing new features.

Nordic Semiconductor ASA reserves the right to change the CRYPTOCELL documentation and register descriptions without further notice. Changes will not trigger erratas and will not be seen as changing form/fit/function of the device.

Please note that Nordic cannot support questions directly related to the register interface or modification of the source code implementation. Nordic provide support for the top-level API in the software library distributed as part of the device SDK.

6.1.2 Usage

The CRYPTOCELL subsystem is a hardware and software solution where software is delivered as libraries in Nordic device SDKs. Recommended usage of the CRYPTOCELL subsystem is to use the SDK library implementation available for the device. The CRYPTOCELL subsystem is documented for reference purpose only, please see section [Disclaimer](#) on page 86 for more information.

To enable CRYPTOCELL, use register [ENABLE](#) on page 92. The device will not enter the System ON IDLE mode until CRYPTOCELL has been disabled, see [POWER — Power control](#) on page 69 for more information. The Nordic SDK software library automatically controls enabling and disabling of the CRYPTOCELL subsystem as a part of its function calls.

6.1.3 Security configuration

CRYPTOCELL has internal storage for its security configuration, which is preserved even if CRYPTOCELL is disabled.

The following configuration settings are retained:

- Device life cycle state (LCS)
- Various lock bits
- 128 bits device root key, K_{DR} , see [Device root key](#) on page 88

Any reset source will erase the CRYPTOCELL internal storage, see [Reset](#) on page 61 for more information.

6.1.3.1 Lifecycle state (LCS)

Lifecycle refers to the multiple states a device goes through during its lifetime. `DebugEnable` and `Secure` are the two CRYPTOCELL lifecycle states available to the device.

The CRYPTOCELL lifecycle state (LCS) is controlled through register [HOST_IOT_LCS](#) on page 150. The LCS is configured by writing either `DebugEnable` or `Secure` to the LCS field of this register. To validate that the register is configured correctly, read back the read-only field `LCS_IS_VALID` from the register [HOST_IOT_LCS](#) on page 150. The `LCS_IS_VALID` field will change from `Invalid` to `Valid` once a valid LCS value is written.

The following debug override functionality is available if LCS is configured as `DebugEnable`:

- Registers [HOST_IOT_KDR0](#) through [HOST_IOT_KDR3](#) can be written multiple times.
- The TRNG output can be overridden. This is done by writing the desired value to register [EHR_DATA\[0\]](#) through [EHR_DATA\[5\]](#) in RNG engine. If LCS is configured as `Secure`, registers `EHR_DATA` are read-only and its content is randomly generated by the RNG engine.

LCS field value	LCS_IS_VALID field value	Description
Secure	Invalid	Default reset value indicating that LCS has not been configured.
Secure	Valid	LCS set to <code>Secure</code> mode, and LCS is valid. Registers HOST_IOT_KDR0 through HOST_IOT_KDR3 can only be written once. Any additional writes are ignored.
DebugEnable	Valid	LCS set to <code>DebugEnable</code> mode, and LCS is valid. Registers HOST_IOT_KDR0 through HOST_IOT_KDR3 can be written multiple times.

Table 14: Lifecycle states

6.1.4 Cryptographic flow

The following section describe a typical cryptographic flow for the CRYPTOCELL subsystem.

1. Enable CRYPTOCELL subsystem as described in [Usage](#) on page 86.
2. Perform clock control for the desired cryptographic engine(s) as described in [Power and clock](#) on page 89.
3. Configure the desired cryptographic mode as described in [CTL interface](#) on page 135.
4. Depending on the selected cryptographic mode the active engine(s) must be configured, including which cryptographic key to use as described in [Cryptographic key selection](#) on page 87.
5. Optionally configure DMA engines as described in [Direct memory access \(DMA\)](#) on page 89.
6. Initiate the operation, and wait for an event as described in [Interrupt handling](#) on page 90.
7. Check status register(s) for the active engine(s).

6.1.5 Cryptographic key selection

The CRYPTOCELL subsystem can operate on different cryptographic keys.

6.1.5.1 Hardware unique keys

The AES engine can be instructed to use different key input sources.

The cryptographic key input for the [AES engine](#) on page 92 can either be a hard-coded RTL key referred to as K_{PRTL} , a device root key referred to as K_{DR} which is typically programmed into CRYPTOCELL during boot by an immutable bootloader, or a session key provided runtime by the application or the [KMU — Key management unit](#) on page 206.

Register [HOST_CRYPTKEY_SEL](#) on page 148 selects one of the following keys for the AES cryptographic operations:

- RTL key K_{PRTL}
- Device root key K_{DR}
- Session key

6.1.5.1.1 RTL key

CRYPTOCELL contains one hard-coded RTL key referred to as K_{PRTL} . This key is set to the same value for all devices with the same part code and cannot be changed.

CRYPTOCELL can perform cryptographic operations using the K_{PRTL} key without a bootloader or application having access to the key value itself. Usage of K_{PRTL} can be disabled until next reset by writing to register [HOST_IOT_KPRTL_LOCK](#) on page 148. If a locked K_{PRTL} key is requested, a zero vector key will be used by the AES engine instead.

6.1.5.1.2 Device root key

The device root key, K_{DR} , is a 128 bits AES key typically programmed by an immutable bootloader as part of the CRYPTOCELL initialization process during device boot sequence. It is kept in the CRYPTOCELL internal storage until the next reset.

To configure the K_{DR} key, write the key value into registers [HOST_IOT_KDR0](#) through [HOST_IOT_KDR3](#). These registers are write-only when LCS is set to `DebugEnable` mode, and write-once when LCS is set to `Secure` mode. The K_{DR} key value is kept when the read-back value of register [HOST_IOT_KDR0](#) is `Retained`. Once configured, CRYPTOCELL can perform cryptographic operations using the K_{DR} key without an updatable bootloader or application having access to the key value itself.

The K_{DR} key should be protected by the [KMU — Key management unit](#) on page 206.

6.1.5.2 Session keys

Session keys are supported by the AES and CHACHA engine.

Before starting a cryptographic operation using a session key, the desired key value must be written in clear-text by the CPU into the write-only key registers of the corresponding engine. One session key can be overwritten by another as long as the write order of the write-only key registers are respected. Please refer to the corresponding chapter of each cryptographic engine for more information about write order.

The [AES engine](#) on page 92 supports 128 bits session keys, and [CHACHA engine](#) on page 98 supports 128/256 bits session keys.

The last written session key for each engine is retained until CRYPTOCELL is disabled, the engine is reset, or the device is reset.

6.1.5.3 Key Management Unit (KMU) keys

The [KMU — Key management unit](#) on page 206 is designed to securely transfer symmetric encryption keys directly into the dedicated write-only key registers of the AES and CHACHA cryptographic engines upon request from the CPU.

Pushing a symmetric key value stored in a KMU key slot into either the AES or CHACHA engine will replace the need for software to write a session key in clear-text into registers [AES_KEY_0\[n\]](#) ($n=0..7$) on page 94 for 128 bits AES keys or registers [CHACHA_KEY\[n\]](#) ($n=0..7$) on page 101 for 128/256 bits CHACHA keys.

The symmetric key value pushed from a KMU key slot into the AES or CHACHA engine will be retained until CRYPTOCELL is disabled or the device is reset.

6.1.5.4 Asymmetric keys

Asymmetric cryptographic keys are supported by the PKA engine.

Before starting a cryptographic operation using an asymmetric key, the desired key value must be written into the PKA SRAM together with the payload.

See [PKA engine](#) on page 111 for more information.

6.1.6 Internal memories

CRYPTOCELL contains two dedicated memory blocks; one 4 kB SRAM block for the PKA engine calculations, and one 2 kB SRAM block for the RNG engine entropy collector.

See [PKA SRAM](#) on page 115 and [RNG SRAM](#) on page 123 for more information about these dedicated memory blocks.

6.1.7 Direct memory access (DMA)

CRYPTOCELL support direct memory access (DMA) to allow cryptographic operations on memory mapped regions without involving the CPU.

The following table indicates which memory is accessible by CRYPTOCELL DMA engines.

Memory type	Read	Write
SRAM	Yes	Yes
Flash	No	No

Table 15: DMA transaction types

Data stored in a memory type not accessible by CRYPTOCELL DMA engines must be copied to an accessible memory type before it can be processed by the CRYPTOCELL subsystem. Maximum DMA transaction size is limited to $2^{16}-1$ bytes.

The CRYPTOCELL DMA engine can also run in Bypass mode, meaning data is read and written without being piped through a cryptographic engine. Thus CRYPTOCELL can act as a general purpose DMA engine for moving data.

Operating the DMA engines in Bypass mode involve the following steps:

1. Enable DMA engines clock using register [DMA_CLK](#) on page 152.
2. Configure cryptographic control for `Bypass` mode using register [CRYPTO_CTL](#) on page 135.
3. Set the the output [destination address](#) and [size](#) of the receiving buffer.
4. Start the DMA transaction by configuring the input [source address](#) and the [number of bytes](#) to transfer.
5. Status of the DMA transaction can be monitored by either polling register [DOUT_DMA_MEM_BUSY](#) on page 141, or by unmasking the interrupt for field `DOUT_TO_MEM_MASK` in register [IMR](#) on page 145.

See [DIN DMA engine](#) on page 136 and [DOUT DMA engine](#) on page 140 for more information.

6.1.8 Power and clock

Power and clock management of the CRYPTOCELL subsystem is handled automatically in hardware, as long as the necessary conditions are fulfilled by software.

Clock gating

CRYPTOCELL implements separate clock domains for each cryptographic engine. Internal clock gating control is handled through the [MISC interface](#) on page 151, as well as register [RNG_CLK](#) on page 131. The registers of a cryptographic engine are only accessible when its clock is enabled.

Power gating

CRYPTOCELL must be disabled to ensure lowest possible power consumption when the subsystem is not needed.

The CRYPTOCELL subsystem power is controlled through register [ENABLE](#) on page 92. Even though external clock input is gated away automatically by hardware, the CRYPTOCELL subsystem power will still be enabled. To initiate a full power-down sequence software must perform the following steps:

1. Make sure there are no pending tasks
2. Clear all pending interrupts in register [RNG_ICR](#) on page 127 and register [ICR](#) on page 146.
3. Disable CRYPTOCELL subsystem using register [ENABLE](#) on page 92.

6.1.9 Interrupt handling

CRYPTOCELL triggers interrupt once processing is complete.

See register [IRR](#) on page 145 for more information on which CRYPTOCELL subsystem components are able to trigger an interrupt request.

To clear the IRQ line when an interrupt has occurred, the relevant interrupt bit in register [ICR](#) on page 146 must be cleared. Interrupt sources can be masked using register [IMR](#) on page 145. If an interrupt source is masked, no interrupt request will be triggered.

In addition if field `RNG_INT` in register [IRR](#) on page 145 is asserted, the relevant RNG engine interrupt bit in register [RNG_ICR](#) on page 127 must be cleared *before* clearing that interrupt bit in register [ICR](#) on page 146 as described above.

The figure below shows how the CRYPTOCELL subsystem interrupt handling is designed and how it is connected to the NVIC module in the CPU.

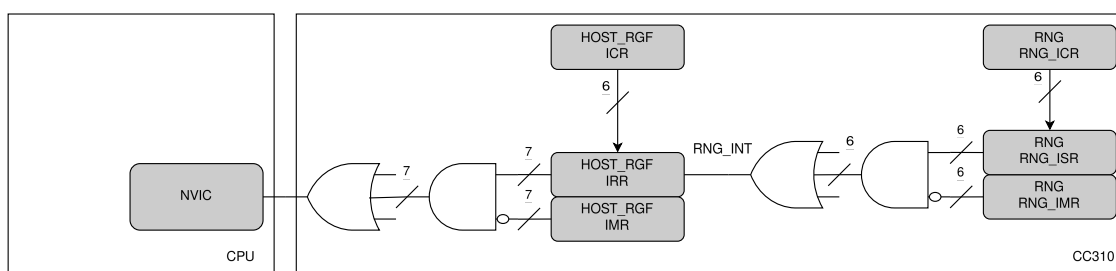

Figure 15: CRYPTOCELL interrupt handling

6.1.10 Standards

Arm TrustZone CryptoCell 310 (CRYPTOCELL) is compliant with the protocol specifications and standards shown in the following table.

Algorithm family	Identification code	Document title
TRNG	NIST SP 800-90B	<i>Recommendation for the Entropy Sources Used for Random Bit Generation</i>
	BIS AIS-31	<i>Functionality Classes and Evaluation Methodology for True Random Number Generators</i>
	FIPS 140-2	<i>Security Requirements for Cryptographic Modules</i>
PRNG	NIST SP 800-90A	<i>Recommendation for Random Number Generation Using Deterministic Random Bit Generators</i>
Stream cipher	ChaCha	<i>ChaCha, a variant of Salsa20</i> , Daniel J. Bernstein, January 28th 2008
MAC	Poly1305	<i>The Poly1305-AES message-authentication code</i> , Daniel J. Bernstein
		<i>Cryptography in NaCl</i> , Daniel J. Bernstein
Key agreement	SRP	<i>The Secure Remote Password Protocol</i> , Thomas Wu, November 11th 1997
Key derivation	NIST SP 800-108	<i>Recommendation for Key Derivation Using Pseudorandom Functions.</i>
AES	FIPS-197	<i>Advanced Encryption Standard (AES)</i> . Compliant with 128 bits key size only
	NIST SP 800-38A	<i>Recommendation for Block Cipher Modes of Operation - Methods and Techniques</i>
	NIST SP 800-38B	<i>Recommendation for Block Cipher Modes of Operation: The CMAC Mode for Authentication</i>
	NIST SP 800-38C	<i>Recommendation for Block Cipher Modes of Operation: The CCM Mode for Authentication and Confidentiality</i>
	ISO/IEC 9797-1	AES CBC-MAC per ISO/IEC 9797-1 MAC algorithm 1
	IEEE 802.15.4-2011	<i>IEEE Standard for Local and metropolitan area networks - Part 15.4: Low-Rate Wireless Personal Area Networks (LR-WPANs)</i> , Annex B.4: <i>Specification of generic CCM* mode of operation</i>
Hash	FIPS 180-4	Secure Hash Standard (SHA1, SHA-224, SHA-256)
	RFC2104	<i>HMAC: Keyed-Hashing for Message Authentication</i>
RSA	PKCS#1	<i>Public-Key Cryptography Standards (PKCS) #1: RSA Cryptography Specifications v1.5/2.1</i> . RSA signature verification supported up to key sizes of 2048 bits. RSA key generation supported up to key sizes of 2048 bits.
Diffie-Hellman	ANSI X9.42	<i>Public Key Cryptography for the Financial Services Industry: Agreement of Symmetric Keys Using Discrete Logarithm Cryptography</i>
	PKCS#3	<i>Diffie-Hellman Key-Agreement Standard</i>
ECC	ANSI X9.63	<i>Public Key Cryptography for the Financial Services Industry - Key Agreement and Key Transport Using Elliptic Curve Cryptography</i>
	IEEE 1363	<i>Standard Specifications for Public-Key Cryptography</i>
	ANSI X9.62	<i>Public Key Cryptography For The Financial Services Industry: The Elliptic Curve Digital Signature Algorithm (ECDSA)</i>
	Ed25519	Edwards-curve, <i>Ed25519: high-speed high-security signatures</i> , Daniel J. Bernstein, Niels Duif, Tanja Lange, Peter Schwabe, and Bo-Yin Yang
	Curve25519	Montgomery curve, <i>Curve25519: new Diffie-Hellman speed records</i> , Daniel J. Bernstein
	FIPS 186-4	<i>Digital Signature Standard (DSS)</i>
	SEC 2	<i>Recommended Elliptic Curve Domain Parameters</i> , Certicom Research
	NIST SP 800-56A rev. 2	<i>Recommendation for Pair-Wise Key Establishment Schemes Using Discrete Logarithm Cryptography</i>

Table 16: CRYPTOCELL cryptography standards

6.1.11 Registers

Instances

Instance	Base address	TrustZone			Split access	Description
		Map	Att	DMA		
CRYPTOCELL	0x50840000	HF	S	NSA	No	CRYPTOCELL 310 security subsystem

Register overview

Register	Offset	TZ	Description
ENABLE	0x500		Enable CRYPTOCELL subsystem.

6.1.11.1 ENABLE

Address offset: 0x500

Enable CRYPTOCELL subsystem.

Bit number	31	30	29	28	27	26	25	24	23	22	21	20	19	18	17	16	15	14	13	12	11	10	9	8	7	6	5	4	3	2	1	0
ID																																A
Reset 0x00000000	0 0																															
ID	R/W	Field	Value ID	Value	Description																											
A	RW	ENABLE			Enable or disable the CRYPTOCELL subsystem.																											
			Disabled	0	CRYPTOCELL subsystem disabled.																											
			Enabled	1	CRYPTOCELL subsystem enabled.																											

6.1.12 Accelerators

This chapter contains register interfaces for each of the hardware accelerator engines.

6.1.12.1 AES engine

The Advanced Encryption Standard (AES) hardware engine is designed according to FIPS197 for use in encrypt/decrypt and sign/verify operations for 128 bits key sizes.

The following cipher modes are supported:

- ECB
- CBC
- CBC-MAC
- CMAC
- CTR
- CCM
- CCM*

Note:

To ensure proper operation when writing 128 bits AES keys, the write-only key registers of the AES engine must be written in ascending order, starting with:

- AES_KEY_0[0]
- AES_KEY_0[1]
- AES_KEY_0[2]
- AES_KEY_0[3]

6.1.12.1.1 Cryptographic flow

The following section describe a simple cryptographic flow for this engine.

```

uint8_t buf_dst[16] = { 0 };
uint8_t buf_src[16] = { 0x81, 0x02, 0xF2, 0x40, 0xD5, 0xB9, 0x44, 0x59,
                      0xA2, 0xEB, 0x6F, 0xF2, 0x49, 0xF5, 0xEB, 0x94 };

/* Enable CRYPTOCELL subsystem */
NRF_CRYPTOCELL->ENABLE = CRYPTOCELL_ENABLE_ENABLE_Enabled;

/* Enable engine and DMA clock */
NRF_CC_MISC->AES_CLK = CC_MISC_AES_CLK_ENABLE_Enable;
NRF_CC_MISC->DMA_CLK = CC_MISC_DMA_CLK_ENABLE_Enable;

/* Wait until crypto engine is Idle */
while (NRF_CC_CTL->CRYPTO_BUSY == CC_CTL_CRYPTO_BUSY_STATUS_Busy) { }

/* Configure AES as cryptographic flow */
NRF_CC_CTL->CRYPTO_CTL = CC_CTL_CRYPTO_CTL_MODE_AESActive;

/* Configure AES engine control for decryption using ECB mode (default) */
NRF_CC_AES->AES_CONTROL = CC_AES_AES_CONTROL_DEC_KEY0_Decrypt;

/* Load the AES key value into the engine */
NRF_CC_AES->AES_KEY_0[0] = 0x51515151;
NRF_CC_AES->AES_KEY_0[1] = 0x52525252;
NRF_CC_AES->AES_KEY_0[2] = 0x53535353;
NRF_CC_AES->AES_KEY_0[3] = 0x54545454;

/* Configure default init vector */
NRF_CC_AES->AES_IV_0[0] = 0x0;
NRF_CC_AES->AES_IV_0[1] = 0x0;
NRF_CC_AES->AES_IV_0[2] = 0x0;
NRF_CC_AES->AES_IV_0[3] = 0x0;

/* Configure DMA output destination address */
NRF_CC_DOUT->DST_MEM_ADDR = (uint32_t) buf_dst;
NRF_CC_DOUT->DST_MEM_SIZE = (uint32_t) sizeof(buf_dst);

/* Configure DMA input source address to start the cryptographic operation */
NRF_CC_DIN->SRC_MEM_ADDR = (uint32_t) buf_src;
NRF_CC_DIN->SRC_MEM_SIZE = (uint32_t) sizeof(buf_src);

/* Wait on DOUT DMA interrupt */
while (!(NRF_CC_HOST_RGF->IRR & CC_HOST_RGF_IRR_DOUT_TO_MEM_INT_Msk)) {}

```

6.1.12.1.2 Registers

Instances

Instance	Base address	TrustZone			Split access	Description
		Map	Att	DMA		
CC_AES	0x50841000	HF	S	NSA	No	CRYPTOCELL AES engine

Register overview

Register	Offset	TZ	Description
AES_KEY_0[n]	0x400		AES key value to use. The initial AES_KEY_0[0] register holds the least significant bits [31:0] of the key value.
AES_IV_0[n]	0x440		AES Initialization Vector (IV) to use. The initial AES_IV_0[0] register holds the least significant bits [31:0] of the IV.
AES_CTR[n]	0x460		AES counter (CTR) to use. The initial AES_CTR[0] register holds the least significant bits [31:0] of the CTR.
AES_BUSY	0x470		Status register for AES engine activity.
AES_SK	0x478		Writing to this address trigger sampling of the HW key to the AES_KEY_0 register
AES_CMAC_INIT	0x47C		Writing to this address triggers the AES engine to generate K1 and K2 for AES-CMAC operations.
AES_REMAINING_BYTES	0x4BC		This register should be set with the amount of remaining bytes until the end of the current AES operation.
AES_CONTROL	0x4C0		Control the AES engine behavior.
AES_HW_FLAGS	0x4C8		Hardware configuration of the AES engine. Reset value holds the supported features.
AES_CTR_NO_INCREMENT	0x4D8		This register enables the AES CTR no increment mode in which the counter mode is not incremented between two blocks
AES_SW_RESET	0x4F4		Reset the AES engine.
AES_CMAC_SIZE0_KICK	0x524		Writing to this address triggers the AES engine to perform a CMAC operation with size 0. The CMAC result can be read from the AES_IV_0 register.

6.1.12.1.2.1 AES_KEY_0[n] (n=0..7)

Address offset: $0x400 + (n \times 0x4)$

AES key value to use. The initial AES_KEY_0[0] register holds the least significant bits [31:0] of the key value.

Bit number	31	30	29	28	27	26	25	24	23	22	21	20	19	18	17	16	15	14	13	12	11	10	9	8	7	6	5	4	3	2	1	0
ID	A	A	A	A	A	A	A	A	A	A	A	A	A	A	A	A	A	A	A	A	A	A	A	A	A	A	A	A	A	A	A	A
Reset 0x00000000	0	0	0	0	0	0	0	0	0	0	0	0	0	0	0	0	0	0	0	0	0	0	0	0	0	0	0	0	0	0	0	
ID	R/W	Field	Value ID	Value	Description																											
A	W	VALUE			AES key value.																											

6.1.12.1.2.2 AES_IV_0[n] (n=0..3)

Address offset: $0x440 + (n \times 0x4)$

AES Initialization Vector (IV) to use. The initial AES_IV_0[0] register holds the least significant bits [31:0] of the IV.

AES_IV_0 must be configured according to the selected AES mode:

- AES CBC/CBC-MAC : Loaded with the IV.

This register is a 'R/W change' register, as the written register values changes during processing.

Bit number	31	30	29	28	27	26	25	24	23	22	21	20	19	18	17	16	15	14	13	12	11	10	9	8	7	6	5	4	3	2	1	0	
ID	A	A	A	A	A	A	A	A	A	A	A	A	A	A	A	A	A	A	A	A	A	A	A	A	A	A	A	A	A	A	A	A	A
Reset 0x00000000	0	0	0	0	0	0	0	0	0	0	0	0	0	0	0	0	0	0	0	0	0	0	0	0	0	0	0	0	0	0	0	0	
ID	R/W	Field	Value ID	Value	Description																												
A	RW	VALUE			AES non-tunneling or first tunnel stage IV value.																												

6.1.12.1.2.3 AES_CTR[n] (n=0..3)

Address offset: 0x460 + (n × 0x4)

AES counter (CTR) to use. The initial AES_CTR[0] register holds the least significant bits [31:0] of the CTR.

AES_CTR must be configured according to the selected AES mode:

- AES CTR : Loaded with the counter value.

This register is a 'R/W change' register, as the written register values changes during processing.

Bit number	31	30	29	28	27	26	25	24	23	22	21	20	19	18	17	16	15	14	13	12	11	10	9	8	7	6	5	4	3	2	1	0
ID	A	A	A	A	A	A	A	A	A	A	A	A	A	A	A	A	A	A	A	A	A	A	A	A	A	A	A	A	A	A	A	
Reset 0x00000000	0	0	0	0	0	0	0	0	0	0	0	0	0	0	0	0	0	0	0	0	0	0	0	0	0	0	0	0	0	0	0	
ID	R/W	Field	Value ID	Value	Description																											
A	RW	VALUE			AES CTR value.																											

6.1.12.1.2.4 AES_BUSY

Address offset: 0x470

Status register for AES engine activity.

Bit number	31	30	29	28	27	26	25	24	23	22	21	20	19	18	17	16	15	14	13	12	11	10	9	8	7	6	5	4	3	2	1	0
ID																																A
Reset 0x00000000	0	0	0	0	0	0	0	0	0	0	0	0	0	0	0	0	0	0	0	0	0	0	0	0	0	0	0	0	0	0	0	
ID	R/W	Field	Value ID	Value	Description																											
A	R	STATUS			AES engine status.																											
			Idle	0	AES engine is idle																											
			Busy	1	AES engine is busy																											

6.1.12.1.2.5 AES_SK

Address offset: 0x478

Writing to this address trigger sampling of the HW key to the AES_KEY_0 register

Bit number	31	30	29	28	27	26	25	24	23	22	21	20	19	18	17	16	15	14	13	12	11	10	9	8	7	6	5	4	3	2	1	0
ID																																A
Reset 0x00000000	0	0	0	0	0	0	0	0	0	0	0	0	0	0	0	0	0	0	0	0	0	0	0	0	0	0	0	0	0	0	0	
ID	R/W	Field	Value ID	Value	Description																											
A	W	AES_SK			Sample HW key to AES_KEY_0 registers.																											

6.1.12.1.2.6 AES_CMAC_INIT

Address offset: 0x47C

Writing to this address triggers the AES engine to generate K1 and K2 for AES-CMAC operations.

Bit number	31	30	29	28	27	26	25	24	23	22	21	20	19	18	17	16	15	14	13	12	11	10	9	8	7	6	5	4	3	2	1	0
ID																																A
Reset 0x00000000	0 0																															
ID	R/W	Field	Value ID	Value	Description																											
A	W	ENABLE	Enable	1	Generate K1 and K2 for the AES-CMAC operations. Initialize AES-CMAC operations.																											

6.1.12.1.2.7 AES_REMAINING_BYTES

Address offset: 0x4BC

This register should be set with the amount of remaining bytes until the end of the current AES operation.

The AES engine counts down from this value to determine the last block or the block before the last blocks in mode AES CMAC and mode AES CCM.

Bit number	31	30	29	28	27	26	25	24	23	22	21	20	19	18	17	16	15	14	13	12	11	10	9	8	7	6	5	4	3	2	1	0
ID	A	A	A	A	A	A	A	A	A	A	A	A	A	A	A	A	A	A	A	A	A	A	A	A	A	A	A	A	A	A	A	
Reset 0x00000000	0 0																															
ID	R/W	Field	Value ID	Value	Description																											
A	RW	VALUE			Remaining bytes until the end of the current AES operation.																											

6.1.12.1.2.8 AES_CONTROL

Address offset: 0x4C0

Control the AES engine behavior.

Bit number	31	30	29	28	27	26	25	24	23	22	21	20	19	18	17	16	15	14	13	12	11	10	9	8	7	6	5	4	3	2	1	0	
ID	E	D																				C	C							B	B	B	A
Reset 0x00000000	0 0																																
ID	R/W	Field	Value ID	Value	Description																												
A	RW	DEC_KEY0	Encrypt	0	Perform AES encryption																												
			Decrypt	1	Perform AES decryption																												
B	RW	MODE_KEY0	ECB	0x0	Electronic codebook mode																												
			CBC	0x1	Cipher block chaining mode																												
			CTR	0x2	Counter mode																												
			CBC_MAC	0x3	Cipher Block Chaining Message Authentication Code																												
			CMAC	0x7	Cipher-based Message Authentication Code																												
C	RW	NK_KEY0	128Bits	0x0	128 bits key length																												
D	RW	AES_XOR_CRYPTKEY	Disable	0	The value that is written to AES_KEY_0 is the value of the HW cryptokey as is.																												
			Enable	1	The value that is written to AES_KEY_0 is the value of the HW cryptokey XOR with the current value of AES_KEY_0.																												
E	RW	DIRECT_ACCESS	Disable	0	Access using the DIN-DOUT DMA interface																												
			Enable	1	Access using direct access																												

6.1.12.1.2.9 AES_HW_FLAGS

Address offset: 0x4C8

Hardware configuration of the AES engine. Reset value holds the supported features.

Bit number	31 30 29 28 27 26 25 24 23 22 21 20 19 18 17 16 15 14 13 12 11 10 9 8 7 6 5 4 3 2 1 0																																																	
ID																														K	J	I	H	G											F	E	D	C	B	A
Reset 0x00000108	0 1 0 0 0 0 1 0 0 0 0																																																	
ID	R/W	Field	Value ID	Value	Description																																													
A	R	SUPPORT_256_192_KEY			If this flag is set, the engine support 192 bits and 256 bits key size.																																													
B	R	AES_LARGE_RKEK			If this flag is set, the engine support AES_LARGE_RKEK.																																													
C	R	DPA_CNTRMSR_EXIST			If this flag is set, the engine support DPA countermeasures.																																													
D	R	CTR_EXIST			If this flag is set, the engine support AES CTR mode.																																													
E	R	ONLY_ENCRYPT			If this flag is set, the engine only support encrypt operations.																																													
F	R	USE_SBOX_TABLE			If this flag is set, the engine uses SBOX tables.																																													
G	R	USE_5_SBOXES			If this flag is set, the engine uses 5 SBOX where each AES round takes 4 cycles.																																													
H	R	AES_SUPPORT_PREV_IV			If this flag is set, the engine contains the PREV_IV register for faster AES XCBC MAC calculation.																																													
I	R	AES_TUNNEL_EXIST			If this flag is set, the engine support tunneling operations.																																													
J	R	SECOND_REGS_SET_EXIST			If this flag is set, the engine support a second register set for tunneling operations.																																													
K	R	DFA_CNTRMSR_EXIST			If this flag is set, the engine support DFA countermeasures.																																													

6.1.12.1.2.10 AES_CTR_NO_INCREMENT

Address offset: 0x4D8

This register enables the AES CTR no increment mode in which the counter mode is not incremented between two blocks

Bit number	31 30 29 28 27 26 25 24 23 22 21 20 19 18 17 16 15 14 13 12 11 10 9 8 7 6 5 4 3 2 1 0																															
ID																																A
Reset 0x00000000	0 0																															
ID	R/W	Field	Value ID	Value	Description																											
A	RW	ENABLE			This field enables the AES CTR no increment mode in which the counter mode is not incremented between two blocks																											
			Disable	0	Counter always incremented between blocks																											
			Enable	1	Do not increment counter between blocks																											

6.1.12.1.2.11 AES_SW_RESET

Address offset: 0x4F4

Reset the AES engine.

Bit number	31 30 29 28 27 26 25 24 23 22 21 20 19 18 17 16 15 14 13 12 11 10 9 8 7 6 5 4 3 2 1 0																															
ID																																A
Reset 0x00000000	0 0																															
ID	R/W	Field	Value ID	Value	Description																											
A	W	RESET			Writing any value to this address resets the AES engine. The reset takes 4 CPU clock cycles to complete.																											
			Enable	1	Reset AES engine.																											

6.1.12.1.2.12 AES_CMAC_SIZE0_KICK

Address offset: 0x524

Writing to this address triggers the AES engine to perform a CMAC operation with size 0. The CMAC result can be read from the AES_IV_0 register.

Bit number	31	30	29	28	27	26	25	24	23	22	21	20	19	18	17	16	15	14	13	12	11	10	9	8	7	6	5	4	3	2	1	0
ID	A																															
Reset 0x00000000	0 0																															
ID	R/W	Field	Value ID	Value	Description																											
A	W	ENABLE			Force AES CMAC operation with size 0.																											
			Disable	0	Normal AES CMAC operation																											
			Enable	1	Force CMAC operation with size 0																											

6.1.12.2 CHACHA engine

The ChaCha algorithm is a family of stream ciphers.

The [ChaCha](#) family of stream ciphers can be used as both a stand-alone algorithm, and in combination with the [Poly1305](#) authenticator to form an Authenticated Encryption with Associated Data (AEAD) algorithm as defined in [RFC7539](#) for IETF protocols.

The CHACHA engine provide acceleration for the stream encryption, while the PKA engine is used for acceleration of the Poly1305 authenticator. The core of the ChaCha algorithm is a hash function which is based on rotation operations. In the default configuration the hash function consist of 20 rounds of rotation permutations. The implementation support ChaCha stream ciphers using key sizes up to 256 bits in 8, 12 and 20 rounds. The ChaCha20/Poly1305 combination is perfectly suited for embedded environments, and can achieve much higher throughput than AES using similar power consumption and execution time.

Note: To ensure proper operation when writing 128 bits CHACHA keys, the write-only key registers of the CHACHA engine must be written in ascending order, starting with:

- CHACHA_KEY[0]
- CHACHA_KEY[1]
- CHACHA_KEY[2]
- CHACHA_KEY[3]

For 256 bits CHACHA keys, this must be followed by:

- CHACHA_KEY[4]
- CHACHA_KEY[5]
- CHACHA_KEY[6]
- CHACHA_KEY[7]

6.1.12.2.1 Cryptographic flow

The following section describe a simple cryptographic flow for this engine.

```

uint8_t buf_dst[16] = { 0 };
uint8_t buf_src[16] = { 0x18, 0x35, 0x9B, 0x75, 0x18, 0x6F, 0x33, 0xBE,
                      0x22, 0x0A, 0x3D, 0xB7, 0x66, 0xFD, 0x98, 0x35 };

/* Enable CRYPTOCELL subsystem */
NRF_CRYPTOCCELL->ENABLE = CRYPTOCELL_ENABLE_ENABLE_Enabled;

/* Enable engine and DMA clock */
NRF_CC_MISC->CHACHA_CLK = CC_MISC_CHACHA_CLK_ENABLE_Enable;
NRF_CC_MISC->DMA_CLK = CC_MISC_DMA_CLK_ENABLE_Enable;

/* Wait until crypto engine is Idle */
while (NRF_CC_CTL->CRYPTO_BUSY == CC_CTL_CRYPTO_BUSY_STATUS_Busy) { }

/* Configure CHACHA as cryptographic flow */
NRF_CC_CTL->CRYPTO_CTL = CC_CTL_CRYPTO_CTL_MODE_ChaChaActive;

/* Configure testing NONCE */
NRF_CC_CHACHA->CHACHA_IV[0] = 0xBBBBAAAA;
NRF_CC_CHACHA->CHACHA_IV[1] = 0x22221111;

/* Load the CHACHA test key value into the engine */
NRF_CC_CHACHA->CHACHA_KEY[0] = 0x51515151;
NRF_CC_CHACHA->CHACHA_KEY[1] = 0x52525252;
NRF_CC_CHACHA->CHACHA_KEY[2] = 0x53535353;
NRF_CC_CHACHA->CHACHA_KEY[3] = 0x54545454;
NRF_CC_CHACHA->CHACHA_KEY[4] = 0x51515151;
NRF_CC_CHACHA->CHACHA_KEY[5] = 0x52525252;
NRF_CC_CHACHA->CHACHA_KEY[6] = 0x53535353;
NRF_CC_CHACHA->CHACHA_KEY[7] = 0x54545454;

/* Configure CHACHA mode - using default (0x0), adding new message init */
NRF_CC_CHACHA->CHACHA_CONTROL =
    (CC_CHACHA_CHACHA_CONTROL_INIT_Enable <<
     CC_CHACHA_CHACHA_CONTROL_INIT_Pos);

/* Configure DMA output destination address */
NRF_CC_DOUT->DST_MEM_ADDR = (uint32_t) buf_dst;
NRF_CC_DOUT->DST_MEM_SIZE = (uint32_t) sizeof(buf_dst);

/* Configure DMA input source address to start the cryptographic operation */
NRF_CC_DIN->SRC_MEM_ADDR = (uint32_t) buf_src;
NRF_CC_DIN->SRC_MEM_SIZE = (uint32_t) sizeof(buf_src);

/* Wait on DOUT DMA interrupt */
while (!(NRF_CC_HOST_RGF->IRR & CC_HOST_RGF_IRR_DOUT_TO_MEM_INT_Msk)) {}

```

6.1.12.2.2 Registers

Instances

Instance	Base address	TrustZone			Split access	Description
		Map	Att	DMA		
CC_CHACHA	0x50841000	HF	S	NSA	No	CRYPTOCELL CHACHA engine

Register overview

Register	Offset	TZ	Description
CHACHA_CONTROL	0x380		Control the CHACHA engine behavior.
CHACHA_VERSION	0x384		CHACHA engine HW version
CHACHA_KEY[n]	0x388		CHACHA key value to use. The initial CHACHA_KEY[0] register holds the least significant bits [31:0] of the key value.
CHACHA_IV[n]	0x3A8		CHACHA Initialization Vector (IV) to use. The IV is also known as the nonce.
CHACHA_BUSY	0x3B0		Status register for CHACHA engine activity.
CHACHA_HW_FLAGS	0x3B4		Hardware configuration of the CHACHA engine. Reset value holds the supported features.
CHACHA_BLOCK_CNT_LSB	0x3B8		Store the LSB value of the block counter, in order to support suspend/resume of operation
CHACHA_BLOCK_CNT_MSB	0x3BC		Store the MSB value of the block counter, in order to support suspend/resume of operation
CHACHA_SW_RESET	0x3C0		Reset the CHACHA engine.
CHACHA_POLY1305_KEY[n]	0x3C4		The auto-generated key to use in Poly1305 MAC calculation. The initial CHACHA_POLY1305_KEY[0] register holds the least significant bits [31:0] of the key value.
CHACHA_ENDIANNES	0x3E4		CHACHA engine data order configuration.
CHACHA_DEBUG	0x3E8		Debug register for the CHACHA engine

6.1.12.2.2.1 CHACHA_CONTROL

Address offset: 0x380

Control the CHACHA engine behavior.

Bit number	31 30 29 28 27 26 25 24 23 22 21 20 19 18 17 16 15 14 13 12 11 10 9 8 7 6 5 4 3 2 1 0																																														
ID																												G	F			E	E	D	C	B	A										
Reset 0x00000000	0 0																																														
ID	R/W	Field	Value ID	Value	Description																																										
A	RW	CHACHA_OR_SALSA			Run engine in ChaCha or Salsa mode																																										
			ChaCha	0	Run engine in ChaCha mode																																										
			Salsa	1	Run engine in Salsa mode																																										
B	RW	INIT			Perform initialization for a new message																																										
			Disable	0	Message already initialized																																										
			Enable	1	Initialize new message																																										
C	RW	GEN_KEY_POLY1305			Generate the key to use in Poly1305 message authentication code calculation.																																										
			Disable	0	Do not generate Poly1305 key																																										
			Enable	1	Generate Poly1305 key																																										
D	RW	KEY_LEN			Key length selection.																																										
			256Bits	0	Use 256 bits key length																																										
			128Bits	1	Use 128 bits key length																																										
E	RW	NUM_OF_ROUNDS			Set number of permutation rounds, default value is 20.																																										
			Default	0	Use 20 rounds of rotation (default)																																										

Bit number	31 30 29 28 27 26 25 24 23 22 21 20 19 18 17 16 15 14 13 12 11 10 9 8 7 6 5 4 3 2 1 0																																																
ID																														G	F			E	E	D	C	B	A										
Reset 0x00000000	0 0																																																
ID	R/W	Field	Value ID	Value	Description																																												
			12Rounds	1	Use 12 rounds of rotation																																												
			8Rounds	2	Use 8 rounds of rotation																																												
F	RW	RESET_BLOCK_CNT			Reset block counter for new messages																																												
			Disable	0	Use current block counter value																																												
			Enable	1	Reset block counter value to zero																																												
G	RW	USE_IV_96BIT			Use 96 bits Initialization Vector (IV)																																												
			Disable	0	Use default size IV of 64 bit																																												
			Enable	1	The IV is 96 bits																																												

6.1.12.2.2.2 CHACHA_VERSION

Address offset: 0x384

CHACHA engine HW version

Bit number	31 30 29 28 27 26 25 24 23 22 21 20 19 18 17 16 15 14 13 12 11 10 9 8 7 6 5 4 3 2 1 0																														
ID	A A																														
Reset 0x00000001	0 1																														
ID	R/W	Field	Value ID	Value	Description																										
A	R	CHACHA_VERSION																													

6.1.12.2.2.3 CHACHA_KEY[n] (n=0..7)

Address offset: 0x388 + (n × 0x4)

CHACHA key value to use. The initial CHACHA_KEY[0] register holds the least significant bits [31:0] of the key value.

Bit number	31 30 29 28 27 26 25 24 23 22 21 20 19 18 17 16 15 14 13 12 11 10 9 8 7 6 5 4 3 2 1 0																														
ID	A A																														
Reset 0x00000000	0 0																														
ID	R/W	Field	Value ID	Value	Description																										
A	W	VALUE			CHACHA key value.																										

6.1.12.2.2.4 CHACHA_IV[n] (n=0..1)

Address offset: 0x3A8 + (n × 0x4)

CHACHA Initialization Vector (IV) to use. The IV is also known as the nonce.

The size of the nonce is controlled from register [CHACHA_CONTROL](#) on page 100.

For 64 bits IV size the nonce value must be encoded using:

- CHACHA_IV[0] : Bits [31:0] of the nonce
- CHACHA_IV[1] : Bits [63:32] of the nonce

For 96 bits IV size the nonce value must be encoded using:

- [CHACHA_BLOCK_CNT_MSB](#) on page 102 : Bits [31:0] of the nonce
- CHACHA_IV[0] : Bits [63:32] of the nonce
- CHACHA_IV[1] : Bits [95:64] of the nonce

Bit number	31	30	29	28	27	26	25	24	23	22	21	20	19	18	17	16	15	14	13	12	11	10	9	8	7	6	5	4	3	2	1	0
ID	A A																															
Reset 0x00000000	0 0																															
ID	R/W	Field	Value ID	Value	Description																											
A	RW	VALUE			CHACHA IV value.																											

6.1.12.2.2.5 CHACHA_BUSY

Address offset: 0x3B0

Status register for CHACHA engine activity.

Bit number	31	30	29	28	27	26	25	24	23	22	21	20	19	18	17	16	15	14	13	12	11	10	9	8	7	6	5	4	3	2	1	0
ID	A																															
Reset 0x00000000	0 0																															
ID	R/W	Field	Value ID	Value	Description																											
A	R	STATUS			CHACHA engine status.																											
			Idle	0	CHACHA engine is idle																											
			Busy	1	CHACHA engine is busy																											

6.1.12.2.2.6 CHACHA_HW_FLAGS

Address offset: 0x3B4

Hardware configuration of the CHACHA engine. Reset value holds the supported features.

Bit number	31	30	29	28	27	26	25	24	23	22	21	20	19	18	17	16	15	14	13	12	11	10	9	8	7	6	5	4	3	2	1	0
ID	C B A																															
Reset 0x00000001	0 1																															
ID	R/W	Field	Value ID	Value	Description																											
A	R	CHACHA_EXISTS			If this flag is set, the engine include ChaCha support																											
B	R	SALSA_EXISTS			If this flag is set, the engine include Salsa support																											
C	R	FAST_CHACHA			If this flag is set, the next matrix calculated when the current one is written to data output path.																											

6.1.12.2.2.7 CHACHA_BLOCK_CNT_LSB

Address offset: 0x3B8

Store the LSB value of the block counter, in order to support suspend/resume of operation

The two first words (n) in the last row of the cipher matrix are the block counter. At the end of each block (512b), the block counter for the next block is written by HW to register [CHACHA_BLOCK_CNT_LSB](#) on page 102 and register [CHACHA_BLOCK_CNT_MSB](#) on page 102. If starting a new message the block counter must also be reset.

Bit number	31	30	29	28	27	26	25	24	23	22	21	20	19	18	17	16	15	14	13	12	11	10	9	8	7	6	5	4	3	2	1	0
ID	A A																															
Reset 0x00000000	0 0																															
ID	R/W	Field	Value ID	Value	Description																											
A	RW	VALUE			This register holds the ChaCha block counter bits [31:0] and must be read and written during respectively suspend and resume operations.																											

6.1.12.2.2.8 CHACHA_BLOCK_CNT_MSB

Address offset: 0x3BC

Store the MSB value of the block counter, in order to support suspend/resume of operation

For the description of register [CHACHA_BLOCK_CNT_MSB](#) on page 102, see register [CHACHA_BLOCK_CNT_LSB](#) on page 102.

Bit number	31	30	29	28	27	26	25	24	23	22	21	20	19	18	17	16	15	14	13	12	11	10	9	8	7	6	5	4	3	2	1	0
ID	A	A	A	A	A	A	A	A	A	A	A	A	A	A	A	A	A	A	A	A	A	A	A	A	A	A	A	A	A	A	A	A
Reset 0x00000000	0	0	0	0	0	0	0	0	0	0	0	0	0	0	0	0	0	0	0	0	0	0	0	0	0	0	0	0	0	0	0	
ID	R/W	Field	Value ID	Value	Description																											
A	RW	VALUE			This register holds the ChaCha block counter bits [63:32] and must be read and written during respectively suspend and resume operations.																											

6.1.12.2.2.9 CHACHA_SW_RESET

Address offset: 0x3C0

Reset the CHACHA engine.

Bit number	31	30	29	28	27	26	25	24	23	22	21	20	19	18	17	16	15	14	13	12	11	10	9	8	7	6	5	4	3	2	1	0
ID																																A
Reset 0x00000000	0	0	0	0	0	0	0	0	0	0	0	0	0	0	0	0	0	0	0	0	0	0	0	0	0	0	0	0	0	0	0	
ID	R/W	Field	Value ID	Value	Description																											
A	W	RESET			Writing any value to this address resets the CHACHA engine. The reset takes 4 CPU clock cycles to complete.																											
			Enable	1	Reset CHACHA engine.																											

6.1.12.2.2.10 CHACHA_POLY1305_KEY[n] (n=0..7)

Address offset: 0x3C4 + (n × 0x4)

The auto-generated key to use in Poly1305 MAC calculation.

The initial CHACHA_POLY1305_KEY[0] register holds the least significant bits [31:0] of the key value.

Bit number	31	30	29	28	27	26	25	24	23	22	21	20	19	18	17	16	15	14	13	12	11	10	9	8	7	6	5	4	3	2	1	0
ID	A	A	A	A	A	A	A	A	A	A	A	A	A	A	A	A	A	A	A	A	A	A	A	A	A	A	A	A	A	A	A	
Reset 0x00000000	0	0	0	0	0	0	0	0	0	0	0	0	0	0	0	0	0	0	0	0	0	0	0	0	0	0	0	0	0	0	0	
ID	R/W	Field	Value ID	Value	Description																											
A	R	VALUE			Poly1305 key value.																											

6.1.12.2.2.11 CHACHA_ENDIANNES

Address offset: 0x3E4

CHACHA engine data order configuration.

Bit number	31	30	29	28	27	26	25	24	23	22	21	20	19	18	17	16	15	14	13	12	11	10	9	8	7	6	5	4	3	2	1	0			
ID																															E	D	C	B	A
Reset 0x00000000	0	0	0	0	0	0	0	0	0	0	0	0	0	0	0	0	0	0	0	0	0	0	0	0	0	0	0	0	0	0	0	0	0		
ID	R/W	Field	Value ID	Value	Description																														
A	RW	CHACHA_DIN_WORD_ORDER			Change the word order of the input data.																														
			Default	0	Use default word order for 128-bits input, where words are ordered as follows: w0, w1, w2, w3.																														
			Reverse	1	Reverses the word order for 128-bits input, where words are re-ordered as follows: w3, w2, w1, w0.																														
B	RW	CHACHA_DIN_BYTE_ORDER			Change the byte order of the input data.																														

Bit number	31 30 29 28 27 26 25 24 23 22 21 20 19 18 17 16 15 14 13 12 11 10 9 8 7 6 5 4 3 2 1 0																																		
ID																															E	D	C	B	A
Reset	0x00000000																																		
0	0	0	0	0	0	0	0	0	0	0	0	0	0	0	0	0	0	0	0	0	0	0	0	0	0	0	0	0	0	0	0	0	0		
ID	R/W	Field	Value ID	Value	Description																														
			Default	0	Use default byte order within each input word, where bytes are ordered as follows: B0, B1, B2, B3.																														
			Reverse	1	Reverse the byte order within each input word, where bytes are re-ordered as follows: B3, B2, B1, B0.																														
C	RW	CHACHA_CORE_MATRIX_LBE_ORDER			Change the quarter of a matrix order in the engine.																														
			Default	0	Use default quarter of matrix order, where quarters are ordered as follows: q0, q1, q2, q3. Each quarter represents a 128-bits section of the matrix.																														
			Reverse	1	Reverse the order of matrix quarters, where quarters are re-ordered as follows: q3, q2, q1, q0. Each quarter represents a 128-bits section of the matrix.																														
D	RW	CHACHA_DOUT_WORD_ORDER			Change the word order of the output data.																														
			Default	0	Uses default word order for 128-bits output, where words are ordered as follows: w0, w1, w2, w3.																														
			Reverse	1	Reverse the word order for 128-bits output, where words are re-ordered as follows: w3, w2, w1, w0.																														
E	RW	CHACHA_DOUT_BYTE_ORDER			Change the byte order of the output data.																														
			Default	0	Use default byte order within each output word, where bytes are ordered as follows: B0, B1, B2, B3.																														
			Reverse	1	Reverse the byte order within each output word, where bytes are re-ordered as follows: B3, B2, B1, B0.																														

6.1.12.2.2.12 CHACHA_DEBUG

Address offset: 0x3E8

Debug register for the CHACHA engine

Bit number	31 30 29 28 27 26 25 24 23 22 21 20 19 18 17 16 15 14 13 12 11 10 9 8 7 6 5 4 3 2 1 0																															
ID																															A	A
Reset	0x00000000																															
0	0	0	0	0	0	0	0	0	0	0	0	0	0	0	0	0	0	0	0	0	0	0	0	0	0	0	0	0	0	0	0	0
ID	R/W	Field	Value ID	Value	Description																											
A	R	FSM_STATE			Reflects the debug state of the CHACHA FSM.																											
			IDLE_STATE	0	CHACHA FSM is in idle state																											
			INIT_STATE	1	CHACHA FSM is in init state																											
			ROUNDS_STATE	2	CHACHA FSM is in rounds state																											
			FINAL_STATE	3	CHACHA FSM is in final state																											

6.1.12.3 HASH engine

The HASH engine is designed according to FIPS 180-4, and support both the SHA1 and SHA2 family of digest algorithms up to 256 bits.

The following SHA modes are supported:

- SHA-1
- SHA-224
- SHA-256

Note:

To ensure proper operation, the FIPS 180-4 defined initial hash values written to the registers of the HASH engine must be written in descending order, starting with:

- `HASH_H[7]` for SHA-256, and SHA-224.
- `HASH_H[6]` for SHA-256, and SHA-224.
- `HASH_H[5]` for SHA-256, and SHA-224.
- `HASH_H[4]` for SHA-256, SHA-224, and SHA-1.
- `HASH_H[3]` for SHA-256, SHA-224, and SHA-1.
- `HASH_H[2]` for SHA-256, SHA-224, and SHA-1.
- `HASH_H[1]` for SHA-256, SHA-224, and SHA-1.
- `HASH_H[0]` for SHA-256, SHA-224, and SHA-1.

6.1.12.3.1 Cryptographic flow

The following section describe a simple cryptographic flow for this engine.

```

uint8_t buf_src[32] = {
    0xFA,0xFA,0xFA,0xFA,0xFA,0xFA,0xFA,0xFA,
    0xFA,0xFA,0xFA,0xFA,0xFA,0xFA,0xFA,0xFA,
    0xFA,0xFA,0xFA,0xFA,0xFA,0xFA,0xFA,0xFA,
    0xFA,0xFA,0xFA,0xFA,0xFA,0xFA,0xFA,0xFA };

/* Enable CRYPTOCELL subsystem */
NRF_CRYPTOCCELL->ENABLE = CRYPTOCCELL_ENABLE_ENABLE_Enabled;

/* Enable engine and DMA clock */
NRF_CC_MISC->HASH_CLK = CC_MISC_HASH_CLK_ENABLE_Enable;
NRF_CC_MISC->DMA_CLK = CC_MISC_DMA_CLK_ENABLE_Enable;

/* Wait until hash engine is Idle */
while (NRF_CC_CTL->HASH_BUSY == CC_CTL_HASH_BUSY_STATUS_Busy) {}

/* Clear all interrupts */
NRF_CC_HOST_RGF->ICR = 0xFFFFFFFF;

/* Configure HASH as cryptographic flow */
NRF_CC_CTL->CRYPTO_CTL = CC_CTL_CRYPTO_CTL_MODE_HashActive;

/* Configure engine for SHA256 */
NRF_CC_HASH->HASH_CONTROL = CC_HASH_HASH_CONTROL_MODE_SHA256;

/* Configure initial SHA256 values */
NRF_CC_HASH->HASH_H[7] = 0x5BE0CD19;
NRF_CC_HASH->HASH_H[6] = 0x1F83D9AB;
NRF_CC_HASH->HASH_H[5] = 0x9B05688C;
NRF_CC_HASH->HASH_H[4] = 0x510E527F;
NRF_CC_HASH->HASH_H[3] = 0xA54FF53A;
NRF_CC_HASH->HASH_H[2] = 0x3C6EF372;
NRF_CC_HASH->HASH_H[1] = 0xBB67AE85;
NRF_CC_HASH->HASH_H[0] = 0x6A09E667;

/* Configure DMA input source address to start the cryptographic operation */
NRF_CC_DIN->SRC_MEM_ADDR = (uint32_t) buf_src;
NRF_CC_DIN->SRC_MEM_SIZE = (uint32_t) sizeof(buf_src);

/* Wait on DIN DMA interrupt indicating data has been fetched */
while(!(NRF_CC_HOST_RGF->IRR & CC_HOST_RGF_IRR_MEM_TO_DIN_INT_Msk)) {}

/* Wait until hash engine is Idle */
while (NRF_CC_CTL->HASH_BUSY == CC_CTL_HASH_BUSY_STATUS_Busy) {}

/* Calculated SHA256 digest now available in
NRF_CC_HASH->HASH_H[0] to NRF_CC_HASH->HASH_H[7] */

```

6.1.12.3.2 Registers

Instances

Instance	Base address	TrustZone			Split access	Description
		Map	Att	DMA		
CC_HASH	0x50841000	HF	S	NSA	No	CRYPTOCELL HASH engine

Register overview

Register	Offset	TZ	Description
HASH_H[n]	0x640		HASH_H value registers. The initial HASH_H[0] register holds the least significant bits [31:0] of the value.
HASH_PAD_AUTO	0x684		Configure the HASH engine to automatically pad data at the end of the DMA transfer to complete the digest operation.
HASH_INIT_STATE	0x694		Configure HASH engine initial state registers.
HASH_VERSION	0x7B0		HASH engine HW version
HASH_CONTROL	0x7C0		Control the HASH engine behavior.
HASH_PAD	0x7C4		Enable the hardware padding feature of the HASH engine.
HASH_PAD_FORCE	0x7C8		Force the hardware padding operation to trigger if the input data length is zero bytes.
HASH_CUR_LEN_0	0x7CC		Bits [31:0] of the number of bytes that have been digested so far.
HASH_CUR_LEN_1	0x7D0		Bits [63:32] of the number of bytes that have been digested so far.
HASH_HW_FLAGS	0x7DC		Hardware configuration of the HASH engine. Reset value holds the supported features.
HASH_SW_RESET	0x7E4		Reset the HASH engine.
HASH_ENDIANNESS	0x7E8		Configure the endianness of HASH data and padding generation.

6.1.12.3.2.1 HASH_H[n] (n=0..7)

Address offset: $0x640 + (n \times 0x4)$

HASH_H value registers. The initial HASH_H[0] register holds the least significant bits [31:0] of the value.

This register is a 'R/W change' register, as the written register values changes during processing.

Bit number	31	30	29	28	27	26	25	24	23	22	21	20	19	18	17	16	15	14	13	12	11	10	9	8	7	6	5	4	3	2	1	0	
ID	A	A	A	A	A	A	A	A	A	A	A	A	A	A	A	A	A	A	A	A	A	A	A	A	A	A	A	A	A	A	A	A	A
Reset 0x00000000	0	0	0	0	0	0	0	0	0	0	0	0	0	0	0	0	0	0	0	0	0	0	0	0	0	0	0	0	0	0	0	0	
ID	R/W	Field	Value ID	Value														Description															

A RW VALUE Write the initial hash value before start of digest operation, and read the final hash value result after the digest operation has been completed.

6.1.12.3.2.2 HASH_PAD_AUTO

Address offset: 0x684

Configure the HASH engine to automatically pad data at the end of the DMA transfer to complete the digest operation.

This feature can only be used if [HASH_PAD](#) on page 109 is enabled, and must be disabled after a digest operation is completed. In the event of zero bytes input data length the hardware padding must be manually triggered using register [HASH_PAD_FORCE](#) on page 109.

Bit number	31	30	29	28	27	26	25	24	23	22	21	20	19	18	17	16	15	14	13	12	11	10	9	8	7	6	5	4	3	2	1	0
ID																																A
Reset	0x00000000																															
	0	0	0	0	0	0	0	0	0	0	0	0	0	0	0	0	0	0	0	0	0	0	0	0	0	0	0	0	0	0	0	0
ID	R/W	Field	Value ID	Value	Description																											
A	W	HWPAD			Enable automatic padding in hardware.																											
			Disable	0	Disable this register when the digest operation is completed.																											
			Enable	1	Do not enable automatic hardware padding.																											
					Enable automatic hardware padding.																											

6.1.12.3.2.3 HASH_INIT_STATE

Address offset: 0x694

Configure HASH engine initial state registers.

Data fetched using the DIN DMA engine will be loaded into initial hash value registers `HASH_H[n]` ($n=0..7$) on page 107 or used as IV for AES MAC.

Bit number	31	30	29	28	27	26	25	24	23	22	21	20	19	18	17	16	15	14	13	12	11	10	9	8	7	6	5	4	3	2	1	0
ID																																A
Reset	0x00000000																															
	0	0	0	0	0	0	0	0	0	0	0	0	0	0	0	0	0	0	0	0	0	0	0	0	0	0	0	0	0	0	0	
ID	R/W	Field	Value ID	Value	Description																											
A	W	LOAD			Enable loading of data to initial state registers. Digest/IV for HASH/AES_MAC.																											
			Disable	0	Disable this register when loading of data using DIN DMA is done.																											
			Enable	1	Disable loading of data to initial state registers.																											
					Enable loading of data to initial state registers.																											

6.1.12.3.2.4 HASH_VERSION

Address offset: 0x7B0

HASH engine HW version

Bit number	31	30	29	28	27	26	25	24	23	22	21	20	19	18	17	16	15	14	13	12	11	10	9	8	7	6	5	4	3	2	1	0
ID																C	C	C	C	B	B	B	B	A	A	A	A	A	A	A	A	A
Reset	0x00000000																															
	0	0	0	0	0	0	0	0	0	0	0	0	0	0	0	0	0	0	0	0	0	0	0	0	0	0	0	0	0	0	0	
ID	R/W	Field	Value ID	Value	Description																											
A	R	PATCH																														
B	R	MINOR_VERSION_NUMBER			Minor version number																											
C	R	MAJOR_VERSION_NUMBER			Major version number																											

6.1.12.3.2.5 HASH_CONTROL

Address offset: 0x7C0

Control the HASH engine behavior.

Bit number	31	30	29	28	27	26	25	24	23	22	21	20	19	18	17	16	15	14	13	12	11	10	9	8	7	6	5	4	3	2	1	0
ID																												A	A	A	A	
Reset	0x00000000																															
	0	0	0	0	0	0	0	0	0	0	0	0	0	0	0	0	0	0	0	0	0	0	0	0	0	0	0	0	0	0	0	
ID	R/W	Field	Value ID	Value	Description																											
A	RW	MODE			Select HASH mode to execute																											
			SHA1	1	Select SHA1 mode																											
			SHA256	2	Select SHA256 mode																											
			SHA224	10	Select SHA224 mode																											

6.1.12.3.2.6 HASH_PAD

Address offset: 0x7C4

Enable the hardware padding feature of the HASH engine.

Bit number	31	30	29	28	27	26	25	24	23	22	21	20	19	18	17	16	15	14	13	12	11	10	9	8	7	6	5	4	3	2	1	0
ID																																A
Reset 0x00000001	0 1																															
ID	R/W	Field	Value ID	Value	Description																											
A	RW	ENABLE			Configure hardware padding feature.																											
			Disable	0	Disable hardware padding feature.																											
			Enable	1	Enable hardware padding feature.																											

6.1.12.3.2.7 HASH_PAD_FORCE

Address offset: 0x7C8

Force the hardware padding operation to trigger if the input data length is zero bytes.

This feature can only be used if [HASH_PAD](#) on page 109 is enabled, and must be disabled after a digest operation is completed.

Bit number	31	30	29	28	27	26	25	24	23	22	21	20	19	18	17	16	15	14	13	12	11	10	9	8	7	6	5	4	3	2	1	0
ID																																A
Reset 0x00000000	0 0																															
ID	R/W	Field	Value ID	Value	Description																											
A	RW	ENABLE			Trigger hardware padding operation.																											
			Disable	0	Disable this register when the digest operation is completed.																											
			Enable	1	Do not force hardware padding to trigger.																											
					Force hardware padding to trigger.																											

6.1.12.3.2.8 HASH_CUR_LEN_0

Address offset: 0x7CC

Bits [31:0] of the number of bytes that have been digested so far.

Bit number	31	30	29	28	27	26	25	24	23	22	21	20	19	18	17	16	15	14	13	12	11	10	9	8	7	6	5	4	3	2	1	0
ID	A	A	A	A	A	A	A	A	A	A	A	A	A	A	A	A	A	A	A	A	A	A	A	A	A	A	A	A	A	A	A	A
Reset 0x00000000	0 0																															
ID	R/W	Field	Value ID	Value	Description																											
A	RW	VALUE			Bits [31:0] of current length of digested data in bytes.																											

6.1.12.3.2.9 HASH_CUR_LEN_1

Address offset: 0x7D0

Bits [63:32] of the number of bytes that have been digested so far.

Bit number	31	30	29	28	27	26	25	24	23	22	21	20	19	18	17	16	15	14	13	12	11	10	9	8	7	6	5	4	3	2	1	0
ID	A	A	A	A	A	A	A	A	A	A	A	A	A	A	A	A	A	A	A	A	A	A	A	A	A	A	A	A	A	A	A	A
Reset 0x00000000	0 0																															
ID	R/W	Field	Value ID	Value	Description																											
A	RW	VALUE			Bits [63:32] of current length of digested data in bytes.																											

6.1.12.3.2.10 HASH_HW_FLAGS

Address offset: 0x7DC

Hardware configuration of the HASH engine. Reset value holds the supported features.

Bit number	31 30 29 28 27 26 25 24 23 22 21 20 19 18 17 16 15 14 13 12 11 10 9 8 7 6 5 4 3 2 1 0																																																										
ID																															J	I	H	G	F	E	D	C	C	C	C	B	B	B	B	A	A	A	A										
Reset 0x00012001	0 0 0 0 0 0 0 0 0 0 0 0 0 0 0 0 1 0 0 1 0 0 0 0 0 0 0 0 0 0 0 0 1																																																										
ID	R/W	Field	Value ID	Value	Description																																																						
A	R	CW			Indicates the number of concurrent words the hash is using to compute signature.																																																						
			One	1	One concurrent word used by hash during signature generation																																																						
			Two	2	Two concurrent words used by hash during signature generation																																																						
B	R	CH			Indicate if Hi adders are present for each Hi value or 1 adder is shared for all Hi.																																																						
			One	0	One Hi value is updated at a time.																																																						
			All	1	All Hi values are updated at the same time.																																																						
C	R	DW			Determine the granularity of word size.																																																						
			32Bits	0	32 bits word data.																																																						
			64Bits	1	64 bits word data.																																																						
D	R	SHA_512_EXISTS			If this flag is set, the engine include SHA-512 support.																																																						
E	R	PAD_EXISTS			If this flag is set, the engine include pad block support.																																																						
F	R	MD5_EXISTS			If this flag is set, the engine include MD5 support.																																																						
G	R	HMAC_EXISTS			If this flag is set, the engine include HMAC support.																																																						
H	R	SHA_256_EXISTS			If this flag is set, the engine include SHA-256 support.																																																						
I	R	HASH_COMPARE_EXISTS			If this flag is set, the engine include compare digest logic.																																																						
J	R	DUMP_HASH_TO_DOUT_EXISTS			If this flag is set, the engine include HASH to DOUT support.																																																						

6.1.12.3.2.11 HASH_SW_RESET

Address offset: 0x7E4

Reset the HASH engine.

Bit number	31 30 29 28 27 26 25 24 23 22 21 20 19 18 17 16 15 14 13 12 11 10 9 8 7 6 5 4 3 2 1 0																														
ID																															A
Reset 0x00000000	0 0																														
ID	R/W	Field	Value ID	Value	Description																										
A	W	RESET			Writing any value to this address resets the HASH engine. The reset takes 4 CPU clock cycles to complete.																										
			Enable	1	Reset HASH engine.																										

6.1.12.3.2.12 HASH_ENDIANNES

Address offset: 0x7E8

Configure the endianness of HASH data and padding generation.

Bit number	31	30	29	28	27	26	25	24	23	22	21	20	19	18	17	16	15	14	13	12	11	10	9	8	7	6	5	4	3	2	1	0
ID	A																															
Reset 0x00000001	0 1																															
ID	R/W	Field	Value ID	Value	Description																											
A	RW	ENDIAN			Endianness of HASH data and padding generation. The default value is little-endian.																											
			LittleEndian	0	Use little-endian format for data and padding																											
			BigEndian	1	Use big-endian format for data and padding																											

6.1.12.4 PKA engine

The Public Key Accelerator (PKA) engine is designed to accelerate asymmetric cryptographic algorithms.

The PKA design is a general purpose bignum modular ALU capable of supporting operand sizes between 128-3136 bits in the following operations:

- Modular exponentiation/inversion
- Modular/regular addition/subtraction
- Modular/regular increment/decrement
- Modular/regular multiplication/division
- Logical operations (AND, OR, XOR, SHIFT)

The PKA engine can be used to hardware accelerate various arithmetic regular and modular mathematical operations involving very large numbers which are used in both RSA and Elliptic Curve Cryptographic (ECC) public-key cryptosystems.

6.1.12.4.1 Virtual memory mapping

The PKA engine uses virtual register mapping to facilitate flexible data management across a variety of cryptographic algorithms.

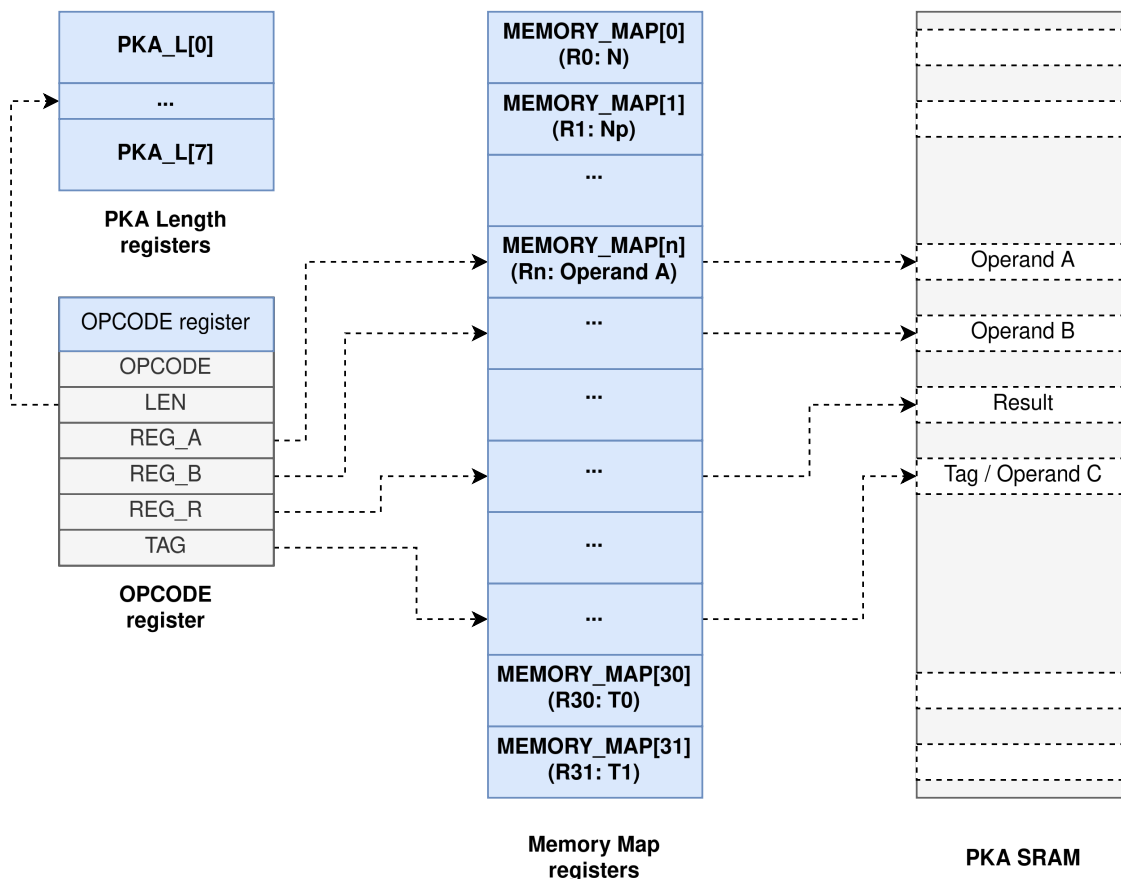

Figure 16: Virtual register mapping

All virtual registers must be defined and configured in the dedicated [PKA SRAM](#) on page 115 before they can be accessed by the PKA engine during processing. This SRAM acts as a private memory pool for the PKA engine, where all other access is blocked during processing. The virtual registers are used as input for the PKA calculation and as a placeholder for intermediate and final results.

The PKA engine can be configured to perform multiple operations on virtual operand registers and store the result of the operation in a virtual result or intermediate result register. During the next iteration the PKA engine can then use an intermediate result register from a previous operation as a virtual operand register for further calculations. This re-mapping strategy enables the PKA engine to efficiently handle complex cryptographic operations.

In total there are 32 virtual registers that can be mapped to different PKA SRAM regions using register [MEMORY_MAP\[n\] \(n=0..31\)](#) on page 117, denoted as virtual register R0 - R31. Four of these 32 virtual registers are special registers, and their register index mapping can be changed using register [N_NP_TO_T1_ADDR](#) on page 118:

- N - holds the modulus number, by default mapped to virtual register R0. This register is used by the PKA engine for modular operations, and its modulus N value does not change during processing.
- Np - holds the inverse modulus number, by default mapped to virtual register R1. This register is used by the PKA engine for the Barrett reduction algorithm, and its inverse modulus Np value does not change during processing.
- T0 - temporary register, by default mapped to virtual register R30. This register is for internal use by the PKA engine.
- T1 - temporary register, by default mapped to virtual register R31. This register is for internal use by the PKA engine.

All virtual registers must be 64 bits word size aligned, and the size of the virtual registers must be at least the size of the largest operand plus an extra 64 bits for internal PKA calculations. These extra 64 bits must be initialized to zero. This is applicable for all virtual registers R0 - R31. The configured virtual register size does not define the size of the operation, it only limits the largest operand size that can be used with the corresponding virtual register.

The memory map configuration can be altered dynamically by the PKA engine, depending on the operation. Not all virtual registers need to be configured for each operation. It is recommended to re-write the memory map configuration after a reset.

6.1.12.4.2 Engine operations

The PKA engine can perform multiple operations on operands stored in virtual registers.

PKA processing is triggered by writing to register [OPCODE](#) on page 118. This register contains both the PKA operation to perform, and which virtual register indexes to use as operand inputs, tag, and intermediate or final result output of the operation. Register [PKA_DONE](#) on page 120 will indicate `Processing` until the PKA operation is done, after which the result can be read from the result register in PKA SRAM.

The following OPCODE virtual register indexes must be configured prior to starting the PKA engine:

- Field `REG_R` configure which virtual register to use for storing an intermediate or final result.
- Field `REG_A` and `REG_B` configure which virtual registers to use as operand input. The operand input fields can be interpreted by the PKA engine as constants instead of virtual register indexes by setting fields `CONST_A` and `CONST_B` for certain operations, as documented in the table below.
- The size of the operands are set in field `LEN`, which must point to one of the pre-configured operand sizes in bits configured in register [PKA_L\[n\] \(n=0..7\)](#) on page 119.

6.1.12.4.2.1 OPCODE overview

Supported PKA operation codes and the corresponding required virtual register configurations.

OPCODE	Operation
Terminate	Terminate ongoing PKA operation
AddInc	Add or Increment <ul style="list-style-type: none"> ADD: $REG_R = REG_A + REG_B$ INC: $REG_R = REG_A + 0x1$, when REG_B and $CONST_B$ are $0x1$
SubDecNeg	Subtract, Decrement, or Negate <ul style="list-style-type: none"> SUB: $REG_R = REG_A - REG_B$ DEC: $REG_R = REG_A - 0x1$, when REG_B and $CONST_B$ are $0x1$ NEG: $REG_R = 0x0 - REG_B$, when REG_A is $0x0$ and $CONST_A$ is $0x1$
ModAddInc	Modular Add or Modular Increment <ul style="list-style-type: none"> ModADD: $REG_R = (REG_A + REG_B) \% REG_N$ ModINC: $REG_R = (REG_A + 0x1) \% REG_N$, when REG_B and $CONST_B$ are $0x1$
ModSubDecNeg	Modular Subtract, Modular Decrement, or Modular Negate <ul style="list-style-type: none"> ModSUB: $REG_R = (REG_A - REG_B) \% REG_N$ ModDEC: $REG_R = (REG_A - 0x1) \% REG_N$, when REG_B and $CONST_B$ is $0x1$ ModNEG: $REG_R = (0x0 - REG_B) \% REG_N$, when REG_A is $0x0$
ANDTSTOCLRO	And, Test bit 0, or Clear <ul style="list-style-type: none"> AND: $REG_R = REG_A \& REG_B$ TSTO: $REG_R = REG_A \& 0x1$, when REG_B is $0x1$, and $CONST_B$ is $0x1$ CLR: $REG_R = 0x0$, when REG_B is $0x0$ and $CONST_B$ is $0x1$. REG_A is ignored.
ORCOPYSET0	Or, Copy, or Set bit 0 <ul style="list-style-type: none"> OR: $REG_R = REG_A REG_B$ COPY: $REG_R = REG_A$, when REG_B is $0x0$ and $CONST_B$ is $0x1$. SET0: $REG_R = REG_A 0x1$, when REG_B and $CONST_B$ is $0x1$.
XORFLPOINVCMP	XOR, Flip bit 0, Invert, or Compare <ul style="list-style-type: none"> XOR: $REG_R = REG_A \# REG_B$ FLPO: $REG_R = REG_A \# 0x1$, when REG_B and $CONST_B$ is $0x1$. INV: $REG_R = REG_A \# 0xFFFFFFFF$, when REG_B is $0x1F$ and $CONST_B$ is $0x1$. CMP: $REG_A \# REG_B$, when $DISCARD_R$ is $0x1$, result of comparison is provided by the ALU_OUT_ZERO flag in PKA_STATUS register.
SHRO	Shift right 0. This operation performs a logical right shift on the contents of REG_A by a specified number of bit positions and stores the result in REG_R . The leftmost bits of REG_R that are vacated by the shift operation are filled with zeros. $REG_R = REG_A \gg s$, $CONST_B$ must be set to $0x1$. To perform s shifts, REG_B should be set to $s - 1$ (where $1 \leq s \leq 31$).
SHR1	Shift right 1. This operation performs a logical right shift on the contents of REG_A by a specified number of bit positions and stores the result in REG_R . The leftmost bits of REG_R that are vacated by the shift operation are filled with ones. $REG_R = REG_A \gg s$, $CONST_B$ must be set to $0x1$. To perform s shifts, REG_B should be set to $s - 1$ (where $1 \leq s \leq 31$).
SHL0	Shift left 0. This operation performs a logical left shift on the contents of REG_A by a specified number of bit positions and stores the result in REG_R . The leftmost bits of REG_R that are vacated by the shift operation are filled with zeros. $REG_R = REG_A \ll s$, $CONST_B$ must be set to $0x1$. To perform s shifts, REG_B should be set to $s - 1$ (where $1 \leq s \leq 31$).
SHL1	Shift left 1. This operation performs a logical left shift on the contents of REG_A by a specified number of bit positions and stores the result in REG_R . The leftmost bits of REG_R that are vacated by the shift operation are filled with ones. $REG_R = REG_A \ll s$, $CONST_B$ must be set to $0x1$. To perform s shifts, REG_B should be set to $s - 1$ (where $1 \leq s \leq 31$).
MulLow	Multiply Low. This operation performs a multiplication of the values in REG_A and REG_B and stores the result in the destination register REG_R . Any bits of the product that exceed the operand size are discarded, effectively keeping only the least significant bits (LSBs) that fit within the operand size.

OPCODE	Operation
	$REG_R = (REG_A * REG_B) \& \text{operand size mask}$
ModMul	Modular Multiply. $REG_R = (REG_A * REG_B) \% REG_N$
ModMulN	The output of this operation is a number that is potentially larger than the modulus N, but guaranteed to be smaller than 2N. Assuming REG_A and REG_B are already reduced modulo N or are less than N, the operation is simply $REG_R = (REG_A * REG_B)$.
ModExp	Modular Exponentiation. $REG_R = (REG_A ^ REG_B) \% REG_N$
Division	Integer Division. This operation performs integer division of the value in REG_A by the value in REG_B. The quotient of the division is stored in REG_R, and the remainder is stored back in REG_A. <ul style="list-style-type: none"> $REG_R = REG_A / REG_B$ $REG_A = REG_A \% REG_B$ <p>If REG_B is zero (0x0), the operation is invalid, and the divide by zero bit in the status register is set to indicate a division error.</p>
ModInv	Modular Inversion. $REG_R = 1/REG_B \% REG_N$
ModDiv	Modular division is done by calculating the modular inverse of the divisor, check that the inverse value exists by examining the GCD, and then use modular multiplication to multiply the inverse result by the divided. $REG_A = (REG_A * REG_B^{(-1)}) \% REG_N$
MulHigh	Multiply High. This operation multiplies REG_A by REG_B and captures the high-order bits of the result that exceed the operand size. It places these significant bits, along with an additional PKA_WORD number of bits, into the destination register REG_R. $REG_R = (REG_A * REG_B) \gg \text{operand size}$
ModMLAC	Modular Multiplication Acceleration. Performs a modular multiplication and addition. REG_C is defined using the operation tag. $REG_R = ((REG_A * REG_B) + REG_C) \% REG_N$
ModMLACNR	Modular Multiplication Acceleration No Reduction. Same as ModMLAC, but this omits the final reduction of the result.
Reduction	Reduction. This operation performs a modular reduction, where the result REG_R is the remainder of REG_A divided by REG_N. The length of the operation is flexible and can be chosen based on the specific requirements of the use case. $REG_R = REG_A \% REG_N$

Table 17: PKA OPCODE descriptions

6.1.12.4.3 Pipeline configuration

The following section describe how the PKA engine is used to accelerate asymmetric cryptographic algorithms.

The PKA engine supports pipelined operations; the pipeline depth is one opcode, thus the next operation can be set up while the previous operation is executing. Register [PKA_PIPE](#) on page 120 will indicate if the pipeline is ready for a new opcode and register [PKA_DONE](#) on page 120 will indicate when the PKA operation has been completed and no operation is waiting in the pipeline.

1. Enable CRYPTOCELL subsystem as described in [Cryptographic flow](#) on page 87.
2. Initialize the PKA engine to accommodate the maximum bit size of all intended operations
 - a. Configure registers [PKA_L\[n\] \(n=0..7\)](#) on page 119 for all required operand bit sizes. The desired operand length is selected using field LEN in register [OPCODE](#) on page 118.
 - b. Define the PKA SRAM memory map partitioning using register [MEMORY_MAP\[n\] \(n=0..31\)](#) on page 117 for register N, Np, T0, and T1, as well as any other virtual registers intended to be used in the operations. The PKA SRAM memory map partitioning must allow for the max operand bit size plus an additional 64 bits reserved for PKA engine internal calculations.
3. For all operations

- a. Load the PKA SRAM virtual registers N and N_p as required
 - b. Load the remaining PKA SRAM virtual registers as required
 - c. Execute the operation by writing register [OPCODE](#) on page 118
 - d. Prepare the next opcode once register [PKA_PIPE](#) on page 120 is ready.
 - e. Handle any status bits in register [PKA_STATUS](#) on page 119
 - f. Re-use intermediate results of the previous operation as needed.
4. Wait for the operation to complete by either polling register [PKA_DONE](#) on page 120, or by unmasking the interrupt for field [PKA_MASK](#) in register [IMR](#) on page 145
 5. Read the result from the result register.

6.1.12.4.4 PKA SRAM

The 4 kB PKA SRAM memory connected to the PKA engine is used exclusively by the engine during cryptographic operations. All access to this memory is blocked while the PKA engine is processing.

The PKA SRAM memory is not directly mapped to the device memory map. Instead, any read or write operation to this memory region must be done using the [PKA engine](#) on page 111.

Writing data to the PKA SRAM involves the following steps:

1. **Set the Address Offset:** Specify the starting byte address for writing by setting register [PKA_SRAM_WADDR](#) on page 120. An offset value of 0×0 points to the first 32-bits word in the PKA SRAM memory. An offset value of 0×10 points to the fourth 32-bits word in the PKA SRAM memory.
2. **Write Data:** After setting the address offset, data is written to register [PKA_SRAM_WDATA](#) on page 121. The address will automatically increment after each write, allowing writes to the next word without needing to set the offset again.

Reading data from the PKA SRAM involves the following steps:

1. **Set the Read Address:** Specify the starting byte address for reading by setting register [PKA_SRAM_RADDR](#) on page 121
2. **Read Data:** Retrieve the data from register [PKA_SRAM_RDATA](#) on page 121. Similar to the write address, the read address will auto-increment with each read, setting it to the next word.

Note: Before switching from writing to reading operations (or vice versa), the PKA SRAM write buffer must be cleared. This is done using register [PKA_SRAM_WCLEAR](#) on page 121. Clearing the buffer ensures that the next operation starts cleanly without any leftover data from the previous operation.

6.1.12.4.5 Cryptographic flow

The following section describe a simple cryptographic flow for this engine.

```

/* Enable CRYPTOCELL and its PKA engine */
NRF_CRYPTOCCELL->ENABLE = CRYPTOCELL_ENABLE_ENABLE_Enabled;
NRF_CC_MISC->PKA_CLK = CC_MISC_PKA_CLK_ENABLE_Enable;

/* Define the operand bit size as 2048 */
NRF_CC_PKA->PKA_L[1] = 0x800;

/* Define the 32-bits PKA SRAM address of the selected R4 and R5 */
NRF_CC_PKA->MEMORY_MAP[4] = 0x108;
NRF_CC_PKA->MEMORY_MAP[5] = 0x14A;

/* Initialize the SRAM registers with one word of data */
NRF_CC_PKA->PKA_SRAM_WADDR = NRF_CC_PKA->MEMORY_MAP[4];
NRF_CC_PKA->PKA_SRAM_WDATA = 0x5;
NRF_CC_PKA->PKA_SRAM_WADDR = NRF_CC_PKA->MEMORY_MAP[5];
NRF_CC_PKA->PKA_SRAM_WDATA = 0x2;

/* Execute subtract, OPCODE SubDecNeg: R4 = R4 - R5 */
NRF_CC_PKA->OPCODE =
    (4 << CC_PKA_OPCODE_REG_R_Pos) |
    (5 << CC_PKA_OPCODE_REG_B_Pos) |
    (4 << CC_PKA_OPCODE_REG_A_Pos) |
    (1 << CC_PKA_OPCODE_LEN_Pos) |
    (CC_PKA_OPCODE_OPCODE_SubDecNeg << CC_PKA_OPCODE_OPCODE_Pos);

/* Wait for operation to complete, result will be in R4 */
while (!NRF_CC_PKA->PKA_DONE) { }

```

This cryptographic flow example perform a subtract operation with the following assumptions:

- All PKA SRAM registers, including the special virtual registers N, N_p, T₀, and T₁, have been cleared before the operation is run.
- The operation is using index 1 in register [PKA_L\[n\] \(n=0..7\)](#) on page 119, which is set to accommodate an operand size of 2048 bits.
- Register R4 and R5 have been selected to run this operation. Register R4 is used both as the operand A register and the result register.
- The memory map is configured to allow operands of 2048 bits plus an additional 64 bits for the internal PKA engine calculations. The configuration of the [MEMORY_MAP\[n\] \(n=0..31\)](#) on page 117 for virtual register N, N_p, T₀, and T₁ is not included in the example. The memory map is thus configured with 66 words per register, leading to the following:

Virtual register	Memory map register	PKA SRAM address
N (R0)	MEMORY_MAP[0]	0x0
Np (R1)	MEMORY_MAP[1]	0x42
...
R4	MEMORY_MAP[4]	0x108
R5	MEMORY_MAP[5]	0x14A
...

6.1.12.4.6 Registers

Instances

Instance	Base address	TrustZone			Split access	Description
		Map	Att	DMA		
CC_PKA	0x50841000	HF	S	NSA	No	CRYPTOCELL PKA engine

Register overview

Register	Offset	TZ	Description
MEMORY_MAP[n]	0x0		Register for mapping the virtual register R[n] to a physical address in the PKA SRAM.
OPCODE	0x80		Operation code to be executed by the PKA engine. Writing to this register triggers the PKA operation.
N_NP_T0_T1_ADDR	0x84		This register defines the N, Np, T0, and T1 virtual register index.
PKA_STATUS	0x88		This register holds the status for the PKA pipeline.
PKA_SW_RESET	0x8C		Reset the PKA engine.
PKA_L[n]	0x90		This register holds the operands bit size.
PKA_PIPE	0xB0		Status register indicating if the PKA pipeline is ready to receive a new OPCODE.
PKA_DONE	0xB4		Status register indicating if the PKA operation has been completed.
PKA_VERSION	0xC4		PKA engine HW version. Reset value holds the version.
PKA_SRAM_WADDR	0xD4		Start address in PKA SRAM for subsequent write transactions.
PKA_SRAM_WDATA	0xD8		Write data to PKA SRAM. Writing to this register triggers a DMA transaction writing data into PKA SRAM. The DMA address offset is automatically incremented during write.
PKA_SRAM_RDATA	0xDC		Read data from PKA SRAM. Reading from this register triggers a DMA transaction read data from PKA SRAM. The DMA address offset is automatically incremented during read.
PKA_SRAM_WCLEAR	0xE0		Register for clearing PKA SRAM write buffer.
PKA_SRAM_RADDR	0xE4		Start address in PKA SRAM for subsequent read transactions.

6.1.12.4.6.1 MEMORY_MAP[n] (n=0..31)

Address offset: $0x0 + (n \times 0x4)$

Register for mapping the virtual register R[n] to a physical address in the PKA SRAM.

Bit number	31	30	29	28	27	26	25	24	23	22	21	20	19	18	17	16	15	14	13	12	11	10	9	8	7	6	5	4	3	2	1	0
ID	A A A A A A A A A A																															
Reset 0x00000000	0 0																															
ID	R/W	Field	Value ID	Value	Description																											
A	RW	ADDR			The physical word address used for the virtual register.																											

6.1.12.4.6.2 OPCODE

Address offset: 0x80

Operation code to be executed by the PKA engine.

Writing to this register triggers the PKA operation.

Bit number	31 30 29 28 27 26 25 24 23 22 21 20 19 18 17 16 15 14 13 12 11 10 9 8 7 6 5 4 3 2 1 0																															
ID	I I I I I H H H G F F F F F E D D D D D C B B B B A A A A A A																															
Reset 0x00000000	0 0																															
ID	R/W	Field	Value ID	Value	Description																											
A	RW	TAG			Holds the operation tag or the operand C virtual register index.																											
B	RW	REG_R			Result register virtual register index.																											
C	RW	DISCARD_R	Register	0x0	REG_R is interpreted as a register index.																											
			Discard	0x1	Result is discarded.																											
D	RW	REG_B			Operand B virtual register index.																											
E	RW	CONST_B	Register	0x0	REG_B is interpreted as a register index.																											
			Constant	0x1	REG_B is interpreted as a constant.																											
F	RW	REG_A			Operand A virtual register index.																											
G	RW	CONST_A	Register	0x0	REG_A is interpreted as a register index.																											
			Constant	0x1	REG_A is interpreted as a constant.																											
H	RW	LEN			The length of the operands. This value serves as an PKA length register index. E.g.: if LEN field value is set to 0, PKA_L[0] holds the size of the operands.																											
I	RW	OPCODE	Terminate	0x0	Terminate operation																											
			AddInc	0x4	Add or Increment																											
			SubDecNeg	0x5	Subtract, Decrement, or Negate																											
			ModAddInc	0x6	Modular Add or Modular Increment																											
			ModSubDecNeg	0x7	Modular Subtract, Modular Decrement, or Modular Negate																											
			ANDTSTOCLR0	0x8	Perform AND, test, or clear																											
			ORCOPYSET0	0x9	Perform OR, copy, or set bits																											
			XORFLPOINVCMP	0xA	Perform XOR, flip bits, invert, or compare																											
			SHR0	0xC	Shift right 0 operation																											
			SHR1	0xD	Shift right 1 operation																											
			SHL0	0xE	Shift left 0 operation																											
			SHL1	0xF	Shift left 1 operation																											
			MulLow	0x10	Multiply low operation																											
			ModMul	0x11	Modular multiply operation																											
			ModMulN	0x12	Modular multiply N operation																											
			ModExp	0x13	Modular exponentiation operation																											
			Division	0x14	Division operation																											
			ModInv	0x15	Modular inversion operation																											
			ModDiv	0x16	Modular division operation																											
			MulHigh	0x17	Multiply high operation																											
ModMLAC	0x18	Modular multiplication acceleration																														
ModMLACNR	0x19	Modular multiplication acceleration where final reduction is omitted																														
Reduction	0x1B	Reduction operation																														

6.1.12.4.6.3 N_NP_T0_T1_ADDR

Address offset: 0x84

This register defines the N, Np, T0, and T1 virtual register index.

Bit number	31 30 29 28 27 26 25 24 23 22 21 20 19 18 17 16 15 14 13 12 11 10 9 8 7 6 5 4 3 2 1 0																															
ID	D D D D C C C C C C B B B B A A A A																															
Reset 0x000FF820	0 0 0 0 0 0 0 0 0 0 0 0 1 1 1 1 1 1 1 1 1 0 0 0 0 0 1 0 0 0 0 0																															
ID	R/W	Field	Value ID	Value	Description																											
A	RW	N_VIRTUAL_ADDR			Register N virtual register index. Default is R0.																											
B	RW	NP_VIRTUAL_ADDR			Register Np virtual register index. Default is R1.																											
C	RW	T0_VIRTUAL_ADDR			Temporary register 0 virtual register index. Default is R30.																											
D	RW	T1_VIRTUAL_ADDR			Temporary register 1 virtual register index. Default is R31.																											

6.1.12.4.6.4 PKA_STATUS

Address offset: 0x88

This register holds the status for the PKA pipeline.

Bit number	31 30 29 28 27 26 25 24 23 22 21 20 19 18 17 16 15 14 13 12 11 10 9 8 7 6 5 4 3 2 1 0																															
ID	K K K K K J I H G F E D C B B B B A A A A																															
Reset 0x00001000	0 1 0 0 0 0 0 0 0 0 0 0 0																															
ID	R/W	Field	Value ID	Value	Description																											
A	R	ALU_MSB_4BITS			The most significant 4-bits of the operand updated in shift operation.																											
B	R	ALU_LSB_4BITS			The least significant 4-bits of the operand updated in shift operation.																											
C	R	ALU_SIGN_OUT			Indicates the MSB sign of the last operation.																											
D	R	ALU_CARRY			Holds the carry of the last ALU operation.																											
E	R	ALU_CARRY_MOD			Holds the carry of the last modular operation.																											
F	R	ALU_SUB_IS_ZERO			Indicates the last subtraction operation sign.																											
G	R	ALU_OUT_ZERO			Indicates if the result of ALU OUT is zero.																											
H	R	ALU_MODOVRFLW			Modular overflow flag.																											
I	R	DIV_BY_ZERO			Indication if the division is done by zero.																											
J	R	MODINV_OF_ZERO			Indicates the modular inverse of zero.																											
K	R	OPCODE			Opcode of the last operation																											

6.1.12.4.6.5 PKA_SW_RESET

Address offset: 0x8C

Reset the PKA engine.

Bit number	31 30 29 28 27 26 25 24 23 22 21 20 19 18 17 16 15 14 13 12 11 10 9 8 7 6 5 4 3 2 1 0																															
ID	A																															
Reset 0x00000000	0 0																															
ID	R/W	Field	Value ID	Value	Description																											
A	W	RESET			Writing any value to this address resets the PKA engine. The reset takes 4 CPU clock cycles to complete.																											
			Enable	1	Reset PKA engine.																											

6.1.12.4.6.6 PKA_L[n] (n=0..7)

Address offset: 0x90 + (n × 0x4)

This register holds the operands bit size.

Bit number	31	30	29	28	27	26	25	24	23	22	21	20	19	18	17	16	15	14	13	12	11	10	9	8	7	6	5	4	3	2	1	0
ID	A A																															
Reset	0x00000000																															
Reset	0	0	0	0	0	0	0	0	0	0	0	0	0	0	0	0	0	0	0	0	0	0	0	0	0	0	0	0	0	0	0	0
ID	R/W	Field	Value ID	Value	Description																											
A	RW	OpSize			Operand bit size.																											

6.1.12.4.6.7 PKA_PIPE

Address offset: 0xB0

Status register indicating if the PKA pipeline is ready to receive a new OPCODE.

Bit number	31	30	29	28	27	26	25	24	23	22	21	20	19	18	17	16	15	14	13	12	11	10	9	8	7	6	5	4	3	2	1	0
ID	A																															
Reset	0x00000001																															
Reset	0	0	0	0	0	0	0	0	0	0	0	0	0	0	0	0	0	0	0	0	0	0	0	0	0	0	0	0	0	0	0	1
ID	R/W	Field	Value ID	Value	Description																											
A	R	STATUS			PKA pipeline status.																											
			NotReady	0	PKA pipeline is not ready for a new OPCODE																											
			Ready	1	PKA pipeline is ready for a new OPCODE																											

6.1.12.4.6.8 PKA_DONE

Address offset: 0xB4

Status register indicating if the PKA operation has been completed.

Bit number	31	30	29	28	27	26	25	24	23	22	21	20	19	18	17	16	15	14	13	12	11	10	9	8	7	6	5	4	3	2	1	0
ID	A																															
Reset	0x00000001																															
Reset	0	0	0	0	0	0	0	0	0	0	0	0	0	0	0	0	0	0	0	0	0	0	0	0	0	0	0	0	0	0	0	1
ID	R/W	Field	Value ID	Value	Description																											
A	R	STATUS			PKA operation status.																											
			Processing	0	PKA operation is processing																											
			Completed	1	PKA operation is completed and pipeline is empty																											

6.1.12.4.6.9 PKA_VERSION

Address offset: 0xC4

PKA engine HW version. Reset value holds the version.

Bit number	31	30	29	28	27	26	25	24	23	22	21	20	19	18	17	16	15	14	13	12	11	10	9	8	7	6	5	4	3	2	1	0	
ID	A	A	A	A	A	A	A	A	A	A	A	A	A	A	A	A	A	A	A	A	A	A	A	A	A	A	A	A	A	A	A	A	
Reset	0x16110215																																
Reset	0	0	0	1	0	1	1	0	0	0	0	1	0	0	0	1	0	0	0	0	0	0	0	1	0	0	0	0	1	0	1	0	1
ID	R/W	Field	Value ID	Value	Description																												
A	R	PKA_VERSION																															

6.1.12.4.6.10 PKA_SRAM_WADDR

Address offset: 0xD4

Start address in PKA SRAM for subsequent write transactions.

Bit number	31	30	29	28	27	26	25	24	23	22	21	20	19	18	17	16	15	14	13	12	11	10	9	8	7	6	5	4	3	2	1	0
ID	A	A	A	A	A	A	A	A	A	A	A	A	A	A	A	A	A	A	A	A	A	A	A	A	A	A	A	A	A	A	A	A
Reset	0	0	0	0	0	0	0	0	0	0	0	0	0	0	0	0	0	0	0	0	0	0	0	0	0	0	0	0	0	0	0	
ID	R/W	Field	Value ID	Value	Description																											
A	W	ADDR			PKA SRAM start address for write transaction																											

6.1.12.4.6.11 PKA_SRAM_WDATA

Address offset: 0xD8

Write data to PKA SRAM. Writing to this register triggers a DMA transaction writing data into PKA SRAM. The DMA address offset is automatically incremented during write.

Bit number	31	30	29	28	27	26	25	24	23	22	21	20	19	18	17	16	15	14	13	12	11	10	9	8	7	6	5	4	3	2	1	0
ID	A	A	A	A	A	A	A	A	A	A	A	A	A	A	A	A	A	A	A	A	A	A	A	A	A	A	A	A	A	A	A	
Reset	0	0	0	0	0	0	0	0	0	0	0	0	0	0	0	0	0	0	0	0	0	0	0	0	0	0	0	0	0	0	0	
ID	R/W	Field	Value ID	Value	Description																											
A	W	DATA			Data to write to PKA SRAM.																											

6.1.12.4.6.12 PKA_SRAM_RDATA

Address offset: 0xDC

Read data from PKA SRAM. Reading from this register triggers a DMA transaction read data from PKA SRAM. The DMA address offset is automatically incremented during read.

Bit number	31	30	29	28	27	26	25	24	23	22	21	20	19	18	17	16	15	14	13	12	11	10	9	8	7	6	5	4	3	2	1	0
ID	A	A	A	A	A	A	A	A	A	A	A	A	A	A	A	A	A	A	A	A	A	A	A	A	A	A	A	A	A	A	A	
Reset	0	0	0	0	0	0	0	0	0	0	0	0	0	0	0	0	0	0	0	0	0	0	0	0	0	0	0	0	0	0	0	
ID	R/W	Field	Value ID	Value	Description																											
A	R	DATA			Data to read from PKA SRAM																											

6.1.12.4.6.13 PKA_SRAM_WCLEAR

Address offset: 0xE0

Register for clearing PKA SRAM write buffer.

Bit number	31	30	29	28	27	26	25	24	23	22	21	20	19	18	17	16	15	14	13	12	11	10	9	8	7	6	5	4	3	2	1	0
ID	A	A	A	A	A	A	A	A	A	A	A	A	A	A	A	A	A	A	A	A	A	A	A	A	A	A	A	A	A	A	A	
Reset	0	0	0	0	0	0	0	0	0	0	0	0	0	0	0	0	0	0	0	0	0	0	0	0	0	0	0	0	0	0	0	
ID	R/W	Field	Value ID	Value	Description																											
A	W	CLEAR			Clear the PKA SRAM write buffer.																											

6.1.12.4.6.14 PKA_SRAM_RADDR

Address offset: 0xE4

Start address in PKA SRAM for subsequent read transactions.

Bit number	31	30	29	28	27	26	25	24	23	22	21	20	19	18	17	16	15	14	13	12	11	10	9	8	7	6	5	4	3	2	1	0
ID	A	A	A	A	A	A	A	A	A	A	A	A	A	A	A	A	A	A	A	A	A	A	A	A	A	A	A	A	A	A	A	
Reset	0	0	0	0	0	0	0	0	0	0	0	0	0	0	0	0	0	0	0	0	0	0	0	0	0	0	0	0	0	0	0	
ID	R/W	Field	Value ID	Value	Description																											
A	W	ADDR			PKA SRAM start address for read transaction																											

6.1.12.5 RNG engine

CRYPTOCELL implements a Random Number Generator (RNG) engine which uses a True Random Number Generator (TRNG) for its entropy collection.

The TRNG is a full entropy design compliant with:

- FIPS 140-2: *Security requirements for Cryptographic Modules*
- BIS AIS-31: *Functionality Classes and Evaluation Methodology for True Random Number Generators*
- NIST SP 800-90B: *Recommendation for the Entropy Sources Used for Random Bit Generation*

where a ring-oscillator is used as the noise source.

The entropy collected using the RNG engine can in turn be used for seeding a Pseudo Random Number Generator (PRNG) as defined in NIST SP 800-90A: *Recommendation for Random Number Generation Using Deterministic Random Bit Generators*.

NIST SP 800-90A define three Deterministic Random Bit Generator (DRBG) that are considered cryptographically secure pseudorandom number generators for use in cryptography: Hash DRBG, HMAC DRBG, and CTR DRBG.

The CRYPTOCELL DRBG implementation is a combination of hardware and software, where CTR DRBG is implemented using the the AES engine running AES encryption in counter (CTR) mode as the underlying cipher. This DRBG instance is seeded with random entropy from the RNG engine.

6.1.12.5.1 Ring oscillator length configuration

The RNG engine must be configured with specific parameters to ensure correct operation in order to output random bits with sufficient entropy.

The noise source used for collecting entropy is based on inverter timing jitter that is collected from a dedicated on-chip free-running ring oscillator. The ring oscillator length, i.e. the number of inverters in the chain, can be configured using register [TRNG_CONFIG](#) on page 128.

In total there are four different ring oscillator lengths that can be selected, referred to as ROSC1 through ROSC4. For each of these four configurable lengths a corresponding sample count value is provided in register [TRNG90B.ROSC1](#) on page 43 through register [TRNG90B.ROSC4](#) on page 44.

The sampling frequency is configured using register [SAMPLE_CNT](#) on page 129, and the programmed value defines the number of CPU clock cycles between two consecutive ring oscillator samples. The configured sample count value is the minimum number of clock cycles that is enough to get independent outputs from the ring oscillator and must match that of the configured ROSC length.

The following steps describe how to set the RNG engine parameters described above:

1. Enable RNG engine clock using register [RNG_CLK](#) on page 131.
2. Reset the RNG engine using register [RNG_SW_RESET](#) on page 130.
3. Re-enable RNG engine clock and select a device-specific sample count from registers [TRNG90B.ROSC1](#) on page 43 through [TRNG90B.ROSC4](#) on page 44 starting with the smallest one, and program the value into register [SAMPLE_CNT](#) on page 129.
4. Perform a readback of the selected sample count value.
5. Set the corresponding ROSC length in register [TRNG_CONFIG](#) on page 128 to match the selected sample count selection.
6. Enable the noise source using register [NOISE_SOURCE](#) on page 128.
7. Wait until event `EHR_VALID_INT` in register [RNG_ISR](#) on page 127 trigger to indicate successful collection of 192 bits of random data. The result can be read from registers `EHR_DATA[n]` ($n=0..5$) on page 128.
8. If events `AUTOCORR_ERR_INT`, `CRNGT_ERR_INT`, or `VNC_ERR_INT` in register [RNG_ISR](#) on page 127 trigger, the RNG engine must be re-configured starting from step 2 above. Increase the ROSC length by a factor of one, and pick the corresponding sample count value from FICR. This step must be

repeated until the collection of 192 bits of random data can be collected without an error event being triggered.

It is recommended to always try the shortest ROSC length first, allowing the RNG engine to complete the entropy collection in a shorter time and keep the ring oscillator turned off for longer periods in order to save power.

6.1.12.5.2 RNG SRAM

The 2 kB SRAM memory connected to the RNG engine can be used for storing a large pool of random entropy.

The RNG SRAM memory is not directly mapped to the device memory map. Instead, any read or write operation using word granularity to this memory region must be done using [RNG SRAM interface](#) on page 150. Larger payloads than word granularity can be processed using the [DIN DMA engine](#) on page 136 and [DOUT DMA engine](#) on page 140.

Before any RNG SRAM read or write transaction can be performed, the CRYPTOCELL must be enabled.

Writing data to the RNG SRAM involves the following steps:

- 1. Set the Address Offset:** Specify the starting byte address for writing by setting register [SRAM_ADDR](#) on page 150. An offset value of 0×0 points to the first 32-bits word in the RNG SRAM memory. An offset value of 0×10 points to the fourth 32-bits word in the RNG SRAM memory.
- 2. Write Data:** When register [SRAM_DATA_READY](#) on page 151 indicates DMA engine is idle, data is written to register [SRAM_DATA](#) on page 150. The address will automatically increment after each write, allowing writes to the next word without needing to set the offset again.

Reading data from the RNG SRAM involves the following steps:

- 1. Set the Read Address:** Specify the starting byte address for reading by setting register [SRAM_ADDR](#) on page 150
- 2. Discard first read:** Read and discard the first value from register [SRAM_DATA](#) on page 150, as it will contain the previous value pointed to by register [SRAM_ADDR](#) on page 150.
- 3. Read Data:** When register [SRAM_DATA_READY](#) on page 151 indicates DMA engine is idle, retrieve the data from register [SRAM_DATA](#) on page 150. Similar to the write address, the read address will auto-increment with each read, setting it to the next word.

Note: Once the address register reaches the last RNG SRAM address, the automatic address incrementation halts. Any subsequent read or write transaction will cause the DMA engine to continue operating on the last 32-bits word in the RNG SRAM memory.

6.1.12.5.3 TRNG hardware tests

The RNG engine has a number of built-in hardware tests for making sure the collected entropy from the TRNG is of sufficient quality.

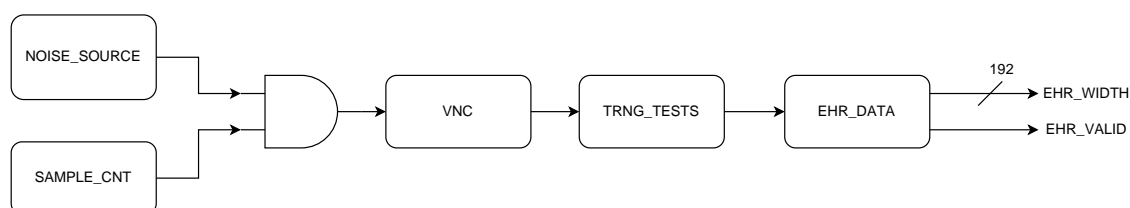

Figure 17: CRYPTOCELL True Random Number Generator

The TRNG collects random bits from the noise source according to the programmed sample counter value in register [SAMPLE_CNT](#) on page 129. The sampled bits are post-processed in a von Neumann corrector (VNC) before being subjected to a continuous random number generation test (CRNGT) and autocorrelation test.

192 bits of random data can be read from the entropy holding registers `EHR_DATA[n]` ($n=0..5$) on page 128 once interrupt `EHR_VALID_INT` in register `RNG_ISR` on page 127 trigger. If this interrupt is masked away in register `RNG_IMR` on page 126, the status register `TRNG_VALID` on page 128 contains field `EHR_DATA` which can be polled when the random data is valid. Reading the most significant word from `EHR_DATA` registers will reset register `TRNG_VALID` and a new 192 bits collection period will start.

Note:

To ensure proper operation when reading 192 bits of random data from the `EHR_DATA` registers of the RNG engine the data must be read in ascending order, starting with:

- `EHR_DATA[0]`
- `EHR_DATA[1]`
- `EHR_DATA[2]`
- `EHR_DATA[3]`
- `EHR_DATA[4]`
- `EHR_DATA[5]`

6.1.12.5.3.1 von Neumann Corrector

The von Neumann Corrector (VNC) is designed to balance the succession of '1' and '0' bits being output by the TRNG noise source.

The input bits to the VNC is tested for bit equality, meaning a sequence of 32 consecutive bits with the same bit value will trigger event `VNC_ERR_INT` in register `RNG_ISR` on page 127.

If no error event is triggered, the input bits will be balanced using the VNC as shown in the figure below, and the resulting output bits will be subjected to additional TRNG tests. The VNC produce output only if the noise source is active, see register `NOISE_SOURCE` on page 128.

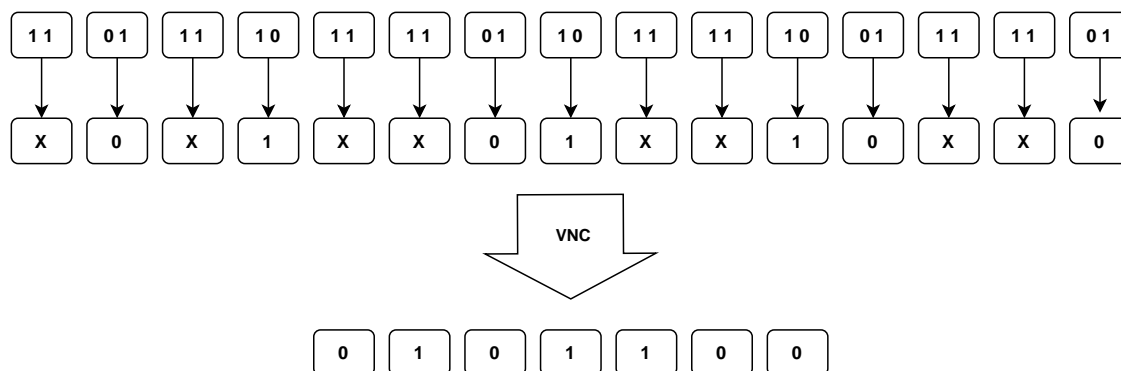

Figure 18: CRYPTOCELL von Neumann corrector

The VNC statistically output one bit for each 4 input bits sampled, meaning the average output rate of the TRNG is $1 / (\text{SAMPLE_CNT} * 4)$ bits per CPU clock cycle.

6.1.12.5.3.2 Continuous random number generation test

The Continuous random number generation test (CRNGT) process the balanced output of random data from the von Neumann corrector.

In the event that two consecutive blocks of 16 collected bits are equal, the CRNGT will trigger event `CRNGT_ERR_INT` in register `RNG_ISR` on page 127.

6.1.12.5.3.3 Autocorrelation test

The Autocorrelation test determine if there over time is a bias in the random bit sequences towards certain values or patterns, or if the bits in the sequence are truly independent.

If a bias in the collected bit stream is detected, the output will be discarded and the error flagged in register [AUTOCORR_STATISTIC](#) on page 129. If a bias is detected four consecutive times in a row, the autocorrelation test will trigger event [AUTOCORR_ERR_INT](#) in register [RNG_ISR](#) on page 127. In this situation the TRNG will cease to function until manually reset using register [RNG_SW_RESET](#) on page 130.

6.1.12.5.4 Cryptographic flow

The following section describe a simple cryptographic flow for this engine.

```

/* Enable CRYPTOCELL subsystem */
NRF_CRYPTOCELL->ENABLE = CRYPTOCELL_ENABLE_ENABLE_Enabled;

/* Enable engine clock */
NRF_CC_RNG->RNG_CLK = CC_RNG_RNG_CLK_ENABLE_Enable;

/* Reset engine */
NRF_CC_RNG->RNG_SW_RESET = CC_RNG_RNG_SW_RESET_RESET_Enable;

/* Configure sampling rate between consecutive bits */
do {
    NRF_CC_RNG->RNG_CLK = CC_RNG_RNG_CLK_ENABLE_Enable;
    NRF_CC_RNG->SAMPLE_CNT = NRF_FICR->TRNG90B.ROSC1;
} while ( NRF_CC_RNG->SAMPLE_CNT != NRF_FICR->TRNG90B.ROSC1 );

/* Configure ROSC length */
NRF_CC_RNG->TRNG_CONFIG = CC_RNG_TRNG_CONFIG_ROSC_LEN_ROSC1;

/* Enable noise source */
NRF_CC_RNG->NOISE_SOURCE = CC_RNG_NOISE_SOURCE_ENABLE_Enabled;

/* Wait for random data to be sampled */
while ((NRF_CC_RNG->RNG_ISR & CC_RNG_RNG_ISR_EHR_VALID_INT_Msk) == 0) {}

/* 192 bits of random data now available in
   NRF_CC_RNG->EHR_DATA[0] to NRF_CC_RNG->EHR_DATA[5] */

```

6.1.12.5.5 Registers

Instances

Instance	Base address	TrustZone			Split access	Description
		Map	Att	DMA		
CC_RNG	0x50841000	HF	S	NSA	No	CRYPTOCELL RNG engine

Register overview

Register	Offset	TZ	Description
RNG_IMR	0x100		Interrupt mask register. Each bit of this register holds the mask of a single interrupt source.

Register	Offset	TZ	Description
RNG_ISR	0x104		Interrupt status register. Each bit of this register holds the interrupt status of a single interrupt source. If corresponding RNG_IMR bit is unmasked, an interrupt is generated.
RNG_ICR	0x108		Interrupt clear register. Writing a 1 bit into a field in this register will clear the corresponding bit in RNG_ISR.
TRNG_CONFIG	0x10C		TRNG ring oscillator length configuration
TRNG_VALID	0x110		This register indicates if TRNG entropy collection is valid.
EHR_DATA[n]	0x114		The entropy holding registers (EHR) hold 192-bits random data collected by the TRNG. The initial EHR_DATA[0] register holds the least significant bits [31:0] of the random data value.
NOISE_SOURCE	0x12C		This register controls the ring oscillator circuit used as a noise source.
SAMPLE_CNT	0x130		Sample count defining the number of CPU clock cycles between two consecutive noise source samples.
AUTOCORR_STATISTIC	0x134		Statistics counter for autocorrelation test activations. Statistics collection is stopped if one of the counters reach its limit of all ones.
TRNG_DEBUG	0x138		Debug register for the TRNG. This register is used to bypass TRNG tests in hardware.
RNG_SW_RESET	0x140		Reset the RNG engine.
RNG_BUSY	0x1B8		Status register for RNG engine activity.
TRNG_RESET	0x1BC		Reset the TRNG, including internal counter of collected bits and registers EHR_DATA and TRNG_VALID.
RNG_HW_FLAGS	0x1C0		Hardware configuration of RNG engine. Reset value holds the supported features.
RNG_CLK	0x1C4		Control clock for the RNG engine.
RNG_DMA	0x1C8		Writing to this register enables the RNG DMA engine.
RNG_DMA_ROSC_LEN	0x1CC		This register defines which ring oscillator length configuration should be used when using the RNG DMA engine.
RNG_DMA_SRAM_ADDR	0x1D0		This register defines the start address in TRNG SRAM for the TRNG data to be collected by the RNG DMA engine.
RNG_DMA_SAMPLES_NUM	0x1D4		This register defines the number of 192-bits samples that the RNG DMA engine collects per run.
RNG_WATCHDOG_VAL	0x1D8		This register defines the maximum number of CPU clock cycles per TRNG collection of 192-bits samples. If the number of cycles for a collection exceeds this threshold the WATCHDOG interrupt is triggered.
RNG_DMA_BUSY	0x1DC		Status register for RNG DMA engine activity.

6.1.12.5.5.1 RNG_IMR

Address offset: 0x100

Interrupt mask register. Each bit of this register holds the mask of a single interrupt source.

Bit number	31 30 29 28 27 26 25 24 23 22 21 20 19 18 17 16 15 14 13 12 11 10 9 8 7 6 5 4 3 2 1 0																																			
ID																															F	E	D	C	B	A
Reset 0x0000003F	0 0																														1	1	1	1	1	
ID	R/W	Field	Value ID	Value	Description																															
A	RW	EHR_VALID_MASK			See RNG_ISR for explanation on this interrupt.																															
			IRQEnable	0	Do not mask EHR interrupt i.e. interrupt is generated																															
			IRQDisable	1	Mask EHR interrupt i.e. no interrupt is generated																															
B	RW	AUTOCORR_ERR_MASK			See RNG_ISR for explanation on this interrupt.																															
			IRQEnable	0	Do not mask autocorrelation interrupt i.e. interrupt is generated																															
			IRQDisable	1	Mask autocorrelation interrupt i.e. no interrupt is generated																															
C	RW	CRNGT_ERR_MASK			See RNG_ISR for explanation on this interrupt.																															
			IRQEnable	0	Do not mask the CRNGT error interrupt i.e. interrupt is generated																															
			IRQDisable	1	Mask the CRNGT error interrupt i.e. no interrupt is generated																															
D	RW	VNC_ERR_MASK			See RNG_ISR for explanation on this interrupt.																															

Bit number	31 30 29 28 27 26 25 24 23 22 21 20 19 18 17 16 15 14 13 12 11 10 9 8 7 6 5 4 3 2 1 0																																																																
ID																															F	E	D	C	B	A																													
Reset 0x0000003F	0																														0	0	0	0	0	0	0	0	0	0	0	0	0	0	0	0	0	0	0	0	0	0	0	0	0	0	0	0	0	1	1	1	1	1	1
ID	R/W	Field	Value ID	Value	Description																																																												
			IRQEnable	0	Do not mask the von Neumann corrector error interrupt i.e. interrupt is generated																																																												
			IRQDisable	1	Mask the von Neumann corrector error interrupt i.e. no interrupt is generated																																																												
E	RW	WATCHDOG_MASK			See RNG_ISR for explanation on this interrupt.																																																												
			IRQEnable	0	Do not mask the watchdog interrupt i.e. interrupt is generated																																																												
			IRQDisable	1	Mask the watchdog interrupt i.e. no interrupt is generated																																																												
F	RW	DMA_DONE_MASK			See RNG_ISR for explanation on this interrupt.																																																												
			IRQEnable	0	Do not mask the RNG DMA completion interrupt i.e. interrupt is generated																																																												
			IRQDisable	1	Mask the RNG DMA completion interrupt i.e. no interrupt is generated																																																												

6.1.12.5.5.2 RNG_ISR

Address offset: 0x104

Interrupt status register. Each bit of this register holds the interrupt status of a single interrupt source. If corresponding RNG_IMR bit is unmasked, an interrupt is generated.

Bit number	31 30 29 28 27 26 25 24 23 22 21 20 19 18 17 16 15 14 13 12 11 10 9 8 7 6 5 4 3 2 1 0																																																														
ID																															F	E	D	C	B	A																											
Reset 0x00000000	0																														0	0	0	0	0	0	0	0	0	0	0	0	0	0	0	0	0	0	0	0	0	0	0	0	0	0	0	0	0	0	0	0	0
ID	R/W	Field	Value ID	Value	Description																																																										
A	R	EHR_VALID_INT			192-bits have been collected and are ready to be read.																																																										
B	R	AUTOCORR_ERR_INT			Autocorrelation error. Failure occurs when autocorrelation test has failed four times in a row. Once set, the TRNG ceases to function until next reset.																																																										
C	R	CRNGT_ERR_INT			Continuous random number generator test error. Failure occurs when two consecutive blocks of 16 collected bits are equal.																																																										
D	R	VNC_ERR_INT			von Neumann corrector error. Failure occurs if 32 consecutive collected bits are identical, ZERO, or ONE.																																																										
E	R	WATCHDOG_INT			Maximum number of CPU clock cycles per sample have been exceeded. See RNG_WATCHDOG_VAL for more information.																																																										
F	R	DMA_DONE_INT			RNG DMA to SRAM is completed.																																																										

6.1.12.5.5.3 RNG_ICR

Address offset: 0x108

Interrupt clear register. Writing a 1 bit into a field in this register will clear the corresponding bit in RNG_ISR.

Bit number	31 30 29 28 27 26 25 24 23 22 21 20 19 18 17 16 15 14 13 12 11 10 9 8 7 6 5 4 3 2 1 0																																																														
ID																															F	E	D	C	B	A																											
Reset 0x00000000	0																														0	0	0	0	0	0	0	0	0	0	0	0	0	0	0	0	0	0	0	0	0	0	0	0	0	0	0	0	0	0	0	0	0
ID	R/W	Field	Value ID	Value	Description																																																										
A	W	EHR_VALID_CLEAR			Writing value '1' clears corresponding bit in RNG_ISR																																																										
B	W	AUTOCORR_ERR_CLEAR			Cannot be cleared by software! Only RNG reset clears this bit.																																																										
C	W	CRNGT_ERR_CLEAR			Writing value '1' clears corresponding bit in RNG_ISR																																																										
D	W	VNC_ERR_CLEAR			Writing value '1' clears corresponding bit in RNG_ISR																																																										
E	W	WATCHDOG_CLEAR			Writing value '1' clears corresponding bit in RNG_ISR																																																										
F	W	DMA_DONE_CLEAR			Writing value '1' clears corresponding bit in RNG_ISR																																																										

6.1.12.5.5.4 TRNG_CONFIG

Address offset: 0x10C

TRNG ring oscillator length configuration

Bit number	31	30	29	28	27	26	25	24	23	22	21	20	19	18	17	16	15	14	13	12	11	10	9	8	7	6	5	4	3	2	1	0
ID	A																															
Reset 0x00000000	0 0																															
ID	R/W	Field	Value ID	Value	Description																											
-A	RW	ROSC_LEN			Set the length of the oscillator ring (= the number of inverters) out of four possible configurations.																											
			ROSC1	0	Use shortest ROSC1 ring oscillator configuration.																											
			ROSC2	1	Use ROSC2 ring oscillator configuration.																											
			ROSC3	2	Use ROSC3 ring oscillator configuration.																											
			ROSC4	3	Use longest ROSC4 ring oscillator configuration.																											

6.1.12.5.5.5 TRNG_VALID

Address offset: 0x110

This register indicates if TRNG entropy collection is valid.

Bit number	31	30	29	28	27	26	25	24	23	22	21	20	19	18	17	16	15	14	13	12	11	10	9	8	7	6	5	4	3	2	1	0
ID	A																															
Reset 0x00000000	0 0																															
ID	R/W	Field	Value ID	Value	Description																											
A	R	EHR_DATA			A value of 1 indicates that collection of bits in the TRNG is completed, and data can be read from EHR_DATA registers.																											
			NotValid	0	Collection of bits not valid.																											
			Valid	1	Collection of bits valid.																											

6.1.12.5.5.6 EHR_DATA[n] (n=0..5)

Address offset: 0x114 + (n × 0x4)

The entropy holding registers (EHR) hold 192-bits random data collected by the TRNG.

The initial EHR_DATA[0] register holds the least significant bits [31:0] of the random data value.

These registers are readable if register `TRNG_VALID` on page 128 is `Valid`. Reading register `EHR_DATA[5]` will clear the content, reset `TRNG_VALID`, and start a new 192 bits collection period.

Bit number	31	30	29	28	27	26	25	24	23	22	21	20	19	18	17	16	15	14	13	12	11	10	9	8	7	6	5	4	3	2	1	0
ID	A	A	A	A	A	A	A	A	A	A	A	A	A	A	A	A	A	A	A	A	A	A	A	A	A	A	A	A	A	A	A	A
Reset 0x00000000	0 0																															
ID	R/W	Field	Value ID	Value	Description																											
A	R	VALUE			Random data value.																											

6.1.12.5.5.7 NOISE_SOURCE

Address offset: 0x12C

This register controls the ring oscillator circuit used as a noise source.

Bit number	31	30	29	28	27	26	25	24	23	22	21	20	19	18	17	16	15	14	13	12	11	10	9	8	7	6	5	4	3	2	1	0	
ID																																A	
Reset	0x00000000																																
0	0	0	0	0	0	0	0	0	0	0	0	0	0	0	0	0	0	0	0	0	0	0	0	0	0	0	0	0	0	0	0	0	0
ID	R/W	Field	Value ID	Value	Description																												
A	RW	ENABLE			Enable or disable the noise source.																												
			Disabled	0	Noise source is disabled																												
			Enabled	1	Noise source is enabled																												

6.1.12.5.5.8 SAMPLE_CNT

Address offset: 0x130

Sample count defining the number of CPU clock cycles between two consecutive noise source samples.

After selecting the desired ring oscillator length configuration in [TRNG_CONFIG](#) on page 128 this register must be set to the corresponding value from [FICR.TRNG90B.ROSC1-4](#).

Bit number	31	30	29	28	27	26	25	24	23	22	21	20	19	18	17	16	15	14	13	12	11	10	9	8	7	6	5	4	3	2	1	0
ID	A	A	A	A	A	A	A	A	A	A	A	A	A	A	A	A	A	A	A	A	A	A	A	A	A	A	A	A	A	A	A	
Reset	0x0000FFFF																															
0	0	0	0	0	0	0	0	0	0	0	0	0	0	0	0	0	0	1	1	1	1	1	1	1	1	1	1	1	1	1	1	
ID	R/W	Field	Value ID	Value	Description																											
A	RW	VALUE			Number of CPU clock cycles between two consecutive noise source samples.																											
					If the von Neumann corrector is bypassed, the minimum value set in this register must not be smaller than decimal 17.																											

6.1.12.5.5.9 AUTOCORR_STATISTIC

Address offset: 0x134

Statistics counter for autocorrelation test activations. Statistics collection is stopped if one of the counters reach its limit of all ones.

Bit number	31	30	29	28	27	26	25	24	23	22	21	20	19	18	17	16	15	14	13	12	11	10	9	8	7	6	5	4	3	2	1	0
ID											B	B	B	B	B	B	B	A	A	A	A	A	A	A	A	A	A	A				
Reset	0x00000000																															
0	0	0	0	0	0	0	0	0	0	0	0	0	0	0	0	0	0	0	0	0	0	0	0	0	0	0	0	0	0	0	0	
ID	R/W	Field	Value ID	Value	Description																											
A	RW	AUTOCORR_TRYS			Count each time an autocorrelation test starts. Any write to the field resets the counter.																											
B	RW	AUTOCORR_FAILS			Count each time an autocorrelation test fails. Any write to the field resets the counter.																											

6.1.12.5.5.10 TRNG_DEBUG

Address offset: 0x138

Debug register for the TRNG. This register is used to bypass TRNG tests in hardware.

Bit number	31 30 29 28 27 26 25 24 23 22 21 20 19 18 17 16 15 14 13 12 11 10 9 8 7 6 5 4 3 2 1 0																																
ID																															C	B	A
Reset 0x00000000	0 0																																
ID	R/W	Field	Value ID	Value	Description																												
A	RW	VNC_BYPASS			Bypass the von Neumann corrector post-processing test, including the 32 consecutive bits test.																												
			Disabled	0	von Neumann corrector post-processing is active																												
			Enabled	1	Bypass the von Neumann corrector																												
B	RW	CRNGT_BYPASS			Bypass the Continuous Random Number Generator Test (CRNGT).																												
			Disabled	0	CRNGT is active																												
			Enabled	1	Bypass CRNGT																												
C	RW	AUTOCORR_BYPASS			Bypass the autocorrelation test.																												
			Disabled	0	Autocorrelation test is active																												
			Enabled	1	Bypass the autocorrelation test																												

6.1.12.5.5.11 RNG_SW_RESET

Address offset: 0x140

Reset the RNG engine.

Bit number	31 30 29 28 27 26 25 24 23 22 21 20 19 18 17 16 15 14 13 12 11 10 9 8 7 6 5 4 3 2 1 0																														
ID																															A
Reset 0x00000000	0 0																														
ID	R/W	Field	Value ID	Value	Description																										
A	W	RESET			Writing any value to this address resets the RNG engine. The reset takes 4 CPU clock cycles to complete.																										
			Enable	1	Reset RNG engine.																										

6.1.12.5.5.12 RNG_BUSY

Address offset: 0x1B8

Status register for RNG engine activity.

Bit number	31 30 29 28 27 26 25 24 23 22 21 20 19 18 17 16 15 14 13 12 11 10 9 8 7 6 5 4 3 2 1 0																														
ID																															B
Reset 0x00000000	0 0																														
ID	R/W	Field	Value ID	Value	Description																										
	R	STATUS			RNG engine status.																										
			Idle	0	RNG engine is idle																										
			Busy	1	RNG engine is busy																										
B	R	TRNG_STATUS			TRNG status.																										
			Idle	0	TRNG is idle																										
			Busy	1	TRNG is busy																										

6.1.12.5.5.13 TRNG_RESET

Address offset: 0x1BC

Reset the TRNG, including internal counter of collected bits and registers EHR_DATA and TRNG_VALID.

Bit number	31 30 29 28 27 26 25 24 23 22 21 20 19 18 17 16 15 14 13 12 11 10 9 8 7 6 5 4 3 2 1 0																															
ID																																A
Reset	0x00000000																															
Reset	0 0																															
ID	R/W	Field	Value ID	Value	Description																											
A	W	RESET			Writing any value to this address resets the internal bits counter and registers EHR_DATA and TRNG_VALID. Register NOISE_SOURCE must be disabled in order for the reset to take place.																											
			Enable	1	Reset TRNG.																											

6.1.12.5.5.14 RNG_HW_FLAGS

Address offset: 0x1C0

Hardware configuration of RNG engine. Reset value holds the supported features.

Bit number	31 30 29 28 27 26 25 24 23 22 21 20 19 18 17 16 15 14 13 12 11 10 9 8 7 6 5 4 3 2 1 0																															
ID																																H G F E D C B A
Reset	0x0000000F																															
Reset	0 1 1 1 1																															
ID	R/W	Field	Value ID	Value	Description																											
A	R	EHR_WIDTH			Data width supported by the entropy collector																											
			128Bits	0	128 bits EHR width																											
			192Bits	1	192 bits EHR width																											
B	R	CRNGT_EXISTS			If this flag is set, the engine include support for continuous random number generator test.																											
C	R	AUTOCORR_EXISTS			If this flag is set, the engine include support for autocorrelation test.																											
D	R	BYPASS_EXISTS			If this flag is set, the engine include support for bypassing TRNG tests.																											
E	R	PRNG_EXISTS			If this flag is set, the engine include a pseudo-random number generator.																											
F	R	KAT_EXISTS			If this flag is set, the engine include support for known answer tests.																											
G	R	RESEEDING_EXISTS			If this flag is set, the engine include support for automatic reseeding.																											
H	R	RNG_USE_5_SBOXES																														
			Disable	0	20 SBOX AES																											
			Enable	1	5 SBOX AES																											

6.1.12.5.5.15 RNG_CLK

Address offset: 0x1C4

Control clock for the RNG engine.

Bit number	31 30 29 28 27 26 25 24 23 22 21 20 19 18 17 16 15 14 13 12 11 10 9 8 7 6 5 4 3 2 1 0																															
ID																																A
Reset	0x00000000																															
Reset	0 0																															
ID	R/W	Field	Value ID	Value	Description																											
A	W	ENABLE			Enables clock for the RNG engine.																											
			Disable	0	Disable clock for RNG engine.																											
			Enable	1	Enable clock for RNG engine.																											

6.1.12.5.5.16 RNG_DMA

Address offset: 0x1C8

Writing to this register enables the RNG DMA engine.

Bit number	31	30	29	28	27	26	25	24	23	22	21	20	19	18	17	16	15	14	13	12	11	10	9	8	7	6	5	4	3	2	1	0
ID																																A
Reset 0x00000000	0 0																															
ID	R/W	Field	Value ID	Value	Description																											
A	RW	ENABLE																														
			Disable	0	Disable RNG DMA engine																											
			Enable	1	Enable RNG DMA engine																											

This value is cleared when the RNG DMA engine completes its operation.

6.1.12.5.5.17 RNG_DMA_ROSC_LEN

Address offset: 0x1CC

This register defines which ring oscillator length configuration should be used when using the RNG DMA engine.

Bit number	31	30	29	28	27	26	25	24	23	22	21	20	19	18	17	16	15	14	13	12	11	10	9	8	7	6	5	4	3	2	1	0			
ID																																D	C	B	A
Reset 0x00000000	0 0																																		
ID	R/W	Field	Value ID	Value	Description																														
A	RW	ROSC1			Use shortest ROSC1 ring oscillator configuration.																														
			Disable	0	Disable ROSC1																														
			Enable	1	Enable ROSC1																														
B	RW	ROSC2			Use ROSC2 ring oscillator configuration.																														
			Disable	0	Disable ROSC2																														
			Enable	1	Enable ROSC2																														
C	RW	ROSC3			Use ROSC3 ring oscillator configuration.																														
			Disable	0	Disable ROSC3																														
			Enable	1	Enable ROSC3																														
D	RW	ROSC4			Use longest ROSC4 ring oscillator configuration.																														
			Disable	0	Disable ROSC4																														
			Enable	1	Enable ROSC4																														

6.1.12.5.5.18 RNG_DMA_SRAM_ADDR

Address offset: 0x1D0

This register defines the start address in TRNG SRAM for the TRNG data to be collected by the RNG DMA engine.

Bit number	31	30	29	28	27	26	25	24	23	22	21	20	19	18	17	16	15	14	13	12	11	10	9	8	7	6	5	4	3	2	1	0												
ID																								A	A	A	A	A	A	A	A	A	A	A	A	A	A	A	A	A	A	A	A	A
Reset 0x00000000	0 0																																											
ID	R/W	Field	Value ID	Value	Description																																							
A	RW	RNG_SRAM_DMA_ADDR			Start address of the TRNG data in TRNG SRAM.																																							

6.1.12.5.5.19 RNG_DMA_SAMPLES_NUM

Address offset: 0x1D4

This register defines the number of 192-bits samples that the RNG DMA engine collects per run.

Bit number	31	30	29	28	27	26	25	24	23	22	21	20	19	18	17	16	15	14	13	12	11	10	9	8	7	6	5	4	3	2	1	0
ID	A A A A A A A A																															
Reset 0x00000000	0 0																															
ID	R/W	Field	Value ID	Value	Description																											
A	RW	RNG_SAMPLES_NUM			Defines the number of 192-bits samples that the DMA engine collects per run.																											

6.1.12.5.5.20 RNG_WATCHDOG_VAL

Address offset: 0x1D8

This register defines the maximum number of CPU clock cycles per TRNG collection of 192-bits samples. If the number of cycles for a collection exceeds this threshold the WATCHDOG interrupt is triggered.

Bit number	31	30	29	28	27	26	25	24	23	22	21	20	19	18	17	16	15	14	13	12	11	10	9	8	7	6	5	4	3	2	1	0
ID	A A																															
Reset 0x00000000	0 0																															
ID	R/W	Field	Value ID	Value	Description																											
A	RW	RNG_WATCHDOG_VAL			Defines the maximum number of CPU clock cycles per TRNG collection of 192-bits samples. If the number of cycles for a collection exceeds this threshold the WATCHDOG interrupt is triggered.																											

6.1.12.5.5.21 RNG_DMA_BUSY

Address offset: 0x1DC

Status register for RNG DMA engine activity.

Bit number	31	30	29	28	27	26	25	24	23	22	21	20	19	18	17	16	15	14	13	12	11	10	9	8	7	6	5	4	3	2	1	0
ID	C C C C C C C C B B A																															
Reset 0x00000000	0 0																															
ID	R/W	Field	Value ID	Value	Description																											
A	R	STATUS			RNG DMA engine status.																											
			Idle	0	RNG DMA engine is idle																											
			Busy	1	RNG DMA engine is busy																											
B	R	ROSC_LEN			The active ring oscillator length configuration used by the RNG DMA engine.																											
			ROSC1	0	Shortest ROSC1 ring oscillator configuration used.																											
			ROSC2	1	ROSC2 ring oscillator configuration used.																											
			ROSC3	2	ROSC3 ring oscillator configuration used.																											
			ROSC4	3	Longest ROSC4 ring oscillator configuration used.																											
C	R	NUM_OF_SAMPLES			Number of samples already collected using the current ring oscillator configuration.																											

6.1.13 Host integration

This chapter describes host registers used to control CRYPTOCELL behavior.

6.1.13.1 AHB interface

The AHB interface controls CRYPTOCELL bus master behavior.

6.1.13.1.1 Registers

Instances

Instance	Base address	TrustZone			Split access	Description
		Map	Att	DMA		
CC_AHB	0x50841000	HF	S	NSA	No	CRYPTOCELL AHB interface

Register overview

Register	Offset	TZ	Description
AHBM_SINGLES	0xB00		This register forces the AHB transactions from CRYPTOCELL master to be always singles.
AHBM_HPROT	0xB04		This register holds the AHB HPROT value
AHBM_HMASTLOCK	0xB08		This register holds AHB HMASTLOCK value
AHBM_HNONSEC	0xB0C		This register holds AHB HNONSEC value

6.1.13.1.1.1 AHBM_SINGLES

Address offset: 0xB00

This register forces the AHB transactions from CRYPTOCELL master to be always singles.

Bit number	31	30	29	28	27	26	25	24	23	22	21	20	19	18	17	16	15	14	13	12	11	10	9	8	7	6	5	4	3	2	1	0
ID																	A															
Reset 0x00000000	0																0															
ID	R/W	Field	Value ID	Value	Description																											
A	RW	AHB_SINGLES			Force AHB singles																											

6.1.13.1.1.2 AHBM_HPROT

Address offset: 0xB04

This register holds the AHB HPROT value

Bit number	31	30	29	28	27	26	25	24	23	22	21	20	19	18	17	16	15	14	13	12	11	10	9	8	7	6	5	4	3	2	1	0
ID																	A A A A															
Reset 0x00000000	0																0															
ID	R/W	Field	Value ID	Value	Description																											
A	RW	AHB_HPROT			The AHB HPROT value																											

6.1.13.1.1.3 AHBM_HMASTLOCK

Address offset: 0xB08

This register holds AHB HMASTLOCK value

Bit number	31	30	29	28	27	26	25	24	23	22	21	20	19	18	17	16	15	14	13	12	11	10	9	8	7	6	5	4	3	2	1	0
ID																	A															
Reset 0x00000000	0																0															
ID	R/W	Field	Value ID	Value	Description																											
A	RW	AHB_HMASTLOCK			The AHB HMASTLOCK value.																											

6.1.13.1.1.4 AHBM_HNONSEC

Address offset: 0xB0C

This register holds AHB HNONSEC value

Bit number	31	30	29	28	27	26	25	24	23	22	21	20	19	18	17	16	15	14	13	12	11	10	9	8	7	6	5	4	3	2	1	0
ID																	B A															
Reset	0x00000000																															
Reset	0 0																															
ID	R/W	Field	Value ID	Value	Description																											
A	RW	AHB_WRITE_HNONSEC			The AHB HNONSEC value for write transaction.																											
B	RW	AHB_READ_HNONSEC			The AHB HNONSEC value for read transaction.																											

6.1.13.2 CTL interface

The CTL interface controls the cryptographic flow and provide busy status for individual components in the CRYPTOCELL subsystem.

6.1.13.2.1 Registers

Instances

Instance	Base address	TrustZone			Split access	Description
		Map	Att	DMA		
CC_CTL	0x50841000	HF	S	NSA	No	CRYPTOCELL CTL interface

Register overview

Register	Offset	TZ	Description
CRYPTO_CTL	0x900		Defines the cryptographic flow.
CRYPTO_BUSY	0x910		Status register for cryptographic cores engine activity.
HASH_BUSY	0x91C		Status register for HASH engine activity.
CONTEXT_ID	0x930		A general-purpose read/write register.

6.1.13.2.1.1 CRYPTO_CTL

Address offset: 0x900

Defines the cryptographic flow.

Bit number	31	30	29	28	27	26	25	24	23	22	21	20	19	18	17	16	15	14	13	12	11	10	9	8	7	6	5	4	3	2	1	0
ID																	A A A A A															
Reset	0x00000000																															
Reset	0 0																															
ID	R/W	Field	Value ID	Value	Description																											
A	W	MODE			Configure the cryptographic engine mode.																											
		Bypass		0	Bypass cryptographic engine																											
		AESActive		1	Use AES engine																											
		AESToHashActive		2	Pipe AES engine output to HASH engine input																											
		AESAndHashActive		3	Process input using both AES and HASH engine in parallel																											
		HashActive		7	Use HASH engine																											
		AESMACAndBypassActive		9	Calculate AES MAC and bypass																											
		AESToHashAndDOUTActive		10	Pipe AES engine output to HASH engine input. The resulting digest output is piped to DOUT buffer.																											
		ChaChaActive		16	Use CHACHA engine																											

6.1.13.2.1.2 CRYPTO_BUSY

Address offset: 0x910

Status register for cryptographic cores engine activity.

This register will be asserted whenever register [AES_BUSY](#) on page 95 or register [HASH_BUSY](#) on page 136 is asserted or when register [DIN_FIFO_EMPTY](#) on page 140 indicate that the DIN FIFO is not empty.

Bit number	31 30 29 28 27 26 25 24 23 22 21 20 19 18 17 16 15 14 13 12 11 10 9 8 7 6 5 4 3 2 1 0																														
ID	A																														
Reset 0x00000000	0 0																														
ID	R/W	Field	Value ID	Value	Description																										
A	R	STATUS			Cryptographic core engines status.																										
			Idle	0	Cryptographic core engines are idle																										
			Busy	1	Cryptographic core engines are busy																										

6.1.13.2.1.3 HASH_BUSY

Address offset: 0x91C

Status register for HASH engine activity.

Bit number	31 30 29 28 27 26 25 24 23 22 21 20 19 18 17 16 15 14 13 12 11 10 9 8 7 6 5 4 3 2 1 0																														
ID	A																														
Reset 0x00000000	0 0																														
ID	R/W	Field	Value ID	Value	Description																										
A	R	STATUS			Hash engine status.																										
			Idle	0	HASH engine is idle																										
			Busy	1	HASH engine is busy																										

6.1.13.2.1.4 CONTEXT_ID

Address offset: 0x930

A general-purpose read/write register.

Bit number	31 30 29 28 27 26 25 24 23 22 21 20 19 18 17 16 15 14 13 12 11 10 9 8 7 6 5 4 3 2 1 0																														
ID	A A A A A A A A																														
Reset 0x00000000	0 0																														
ID	R/W	Field	Value ID	Value	Description																										
A	RW	CONTEXT_ID			Context ID																										

6.1.13.3 DIN DMA engine

The Data IN (DIN) DMA engine transfers data into the CRYPTOCELL subsystem and its various cryptographic engines.

The DIN DMA engine provides a comprehensive interface for to facilitate the transfer of data from the CPU or memory to the cryptographic engines. It includes a variety of registers that control direct data buffering, DMA operations, and data flow management.

Maximum DMA transaction size is limited to $2^{16}-1$ bytes. If a DMA transaction is configured with a payload size above the maximum DMA transaction size limit, the DMA engine must be reset before being functional again using register [DIN_SW_RESET](#) on page 139.

The flow demonstrated in [Cryptographic flow](#) on page 93 shows how the DIN DMA engine is configured to provide data to the AES engine using registers [SRC_MEM_ADDR](#) on page 138 and

[SRC_MEM_SIZE](#) on page 138 to define the input source address and number of input bytes, respectively.

6.1.13.3.1 Registers

Instances

Instance	Base address	TrustZone			Split access	Description
		Map	Att	DMA		
CC_DIN	0x50841000	HF	S	NSA	No	CRYPTOCELL DIN DMA engine

Register overview

Register	Offset	TZ	Description
DIN_BUFFER	0xC00		Used by CPU to write data directly to the DIN buffer, which is then sent to the cryptographic engines for processing.
DIN_DMA_MEM_BUSY	0xC20		Status register for DIN DMA engine activity when accessing memory.
SRC_MEM_ADDR	0xC28		Data source address in memory.
SRC_MEM_SIZE	0xC2C		The number of bytes to be read from memory. Writing to this register triggers the DMA operation.
SRC_SRAM_ADDR	0xC30		Data source address in RNG SRAM.
SRC_SRAM_SIZE	0xC34		The number of bytes to be read from RNG SRAM. Writing to this register triggers the DMA operation.
DIN_DMA_SRAM_BUSY	0xC38		Status register for DIN DMA engine activity when accessing RNG SRAM.
DIN_DMA_SRAM_ENDIANNES	0xC3C		Configure the endianness of DIN DMA transactions towards RNG SRAM.
DIN_SW_RESET	0xC44		Reset the DIN DMA engine.
DIN_CPU_DATA	0xC48		Specifies the number of bytes the CPU will write to the DIN_BUFFER , ensuring the cryptographic engine processes the correct amount of data.
DIN_WRITE_ALIGN	0xC4C		Indicates that the next CPU write to the DIN_BUFFER is the last in the sequence. This is needed only when the data size is NOT modulo 4 (e.g. HASH padding).
DIN_FIFO_EMPTY	0xC50		Register indicating if DIN FIFO is empty and if more data can be accepted.
DIN_FIFO_RESET	0xC58		Reset the DIN FIFO, effectively clearing the FIFO for new data.

6.1.13.3.1.1 DIN_BUFFER

Address offset: 0xC00

Used by CPU to write data directly to the DIN buffer, which is then sent to the cryptographic engines for processing.

The number of bytes to write is defined in [DIN_CPU_DATA](#) on page 139.

Bit number	31	30	29	28	27	26	25	24	23	22	21	20	19	18	17	16	15	14	13	12	11	10	9	8	7	6	5	4	3	2	1	0
ID	A	A	A	A	A	A	A	A	A	A	A	A	A	A	A	A	A	A	A	A	A	A	A	A	A	A	A	A	A	A	A	
Reset 0x00000000	0	0	0	0	0	0	0	0	0	0	0	0	0	0	0	0	0	0	0	0	0	0	0	0	0	0	0	0	0	0	0	
ID	R/W	Field	Value ID	Value	Description																											
A	W	DATA			This register is mapped into 8 addresses in order to enable a CPU burst.																											

6.1.13.3.1.2 DIN_DMA_MEM_BUSY

Address offset: 0xC20

Status register for DIN DMA engine activity when accessing memory.

Bit number	31	30	29	28	27	26	25	24	23	22	21	20	19	18	17	16	15	14	13	12	11	10	9	8	7	6	5	4	3	2	1	0
ID	A																															
Reset 0x00000000	0 0																															
ID	R/W	Field	Value ID	Value	Description																											
A	R	STATUS			DIN memory DMA engine status.																											
			Idle	0	DIN memory DMA engine is idle																											
			Busy	1	DIN memory DMA engine is busy																											

6.1.13.3.1.3 SRC_MEM_ADDR

Address offset: 0xC28

Data source address in memory.

Bit number	31	30	29	28	27	26	25	24	23	22	21	20	19	18	17	16	15	14	13	12	11	10	9	8	7	6	5	4	3	2	1	0
ID	A	A	A	A	A	A	A	A	A	A	A	A	A	A	A	A	A	A	A	A	A	A	A	A	A	A	A	A	A	A	A	A
Reset 0x00000000	0 0																															
ID	R/W	Field	Value ID	Value	Description																											
A	W	ADDR			Source address in memory.																											

6.1.13.3.1.4 SRC_MEM_SIZE

Address offset: 0xC2C

The number of bytes to be read from memory. Writing to this register triggers the DMA operation.

Bit number	31	30	29	28	27	26	25	24	23	22	21	20	19	18	17	16	15	14	13	12	11	10	9	8	7	6	5	4	3	2	1	0
ID	C	B	A	A	A	A	A	A	A	A	A	A	A	A	A	A	A	A	A	A	A	A	A	A	A	A	A	A	A	A	A	
Reset 0x00000000	0 0																															
ID	R/W	Field	Value ID	Value	Description																											
A	W	SIZE			Total number of bytes to read from memory.																											
B	W	FIRST			This field is reserved																											
C	W	LAST			This field is reserved																											

6.1.13.3.1.5 SRC_SRAM_ADDR

Address offset: 0xC30

Data source address in RNG SRAM.

Bit number	31	30	29	28	27	26	25	24	23	22	21	20	19	18	17	16	15	14	13	12	11	10	9	8	7	6	5	4	3	2	1	0
ID	A	A	A	A	A	A	A	A	A	A	A	A	A	A	A	A	A	A	A	A	A	A	A	A	A	A	A	A	A	A	A	
Reset 0x00000000	0 0																															
ID	R/W	Field	Value ID	Value	Description																											
A	RW	ADDR			Source address in RNG SRAM.																											

6.1.13.3.1.6 SRC_SRAM_SIZE

Address offset: 0xC34

The number of bytes to be read from RNG SRAM. Writing to this register triggers the DMA operation.

Bit number	31	30	29	28	27	26	25	24	23	22	21	20	19	18	17	16	15	14	13	12	11	10	9	8	7	6	5	4	3	2	1	0
ID	A																															
Reset 0x00000000	0																															
ID	R/W	Field	Value ID	Value	Description																											
A	W	SIZE			Total number of bytes to read from RNG SRAM.																											

6.1.13.3.1.7 DIN_DMA_SRAM_BUSY

Address offset: 0xC38

Status register for DIN DMA engine activity when accessing RNG SRAM.

Bit number	31	30	29	28	27	26	25	24	23	22	21	20	19	18	17	16	15	14	13	12	11	10	9	8	7	6	5	4	3	2	1	0
ID	A																															
Reset 0x00000000	0																															
ID	R/W	Field	Value ID	Value	Description																											
A	R	STATUS			DIN RNG SRAM DMA engine status.																											
			Idle	0	DIN RNG SRAM DMA engine is idle																											
			Busy	1	DIN RNG SRAM DMA engine is busy																											

6.1.13.3.1.8 DIN_DMA_SRAM_ENDIANNES

Address offset: 0xC3C

Configure the endianness of DIN DMA transactions towards RNG SRAM.

Bit number	31	30	29	28	27	26	25	24	23	22	21	20	19	18	17	16	15	14	13	12	11	10	9	8	7	6	5	4	3	2	1	0
ID	A																															
Reset 0x00000000	0																															
ID	R/W	Field	Value ID	Value	Description																											
A	RW	ENDIAN			Endianness of DIN DMA transactions towards RNG SRAM. The default value is little-endian.																											
			LittleEndian	0	Use little-endian format for RNG SRAM DMA transactions																											
			BigEndian	1	Use big-endian format for RNG SRAM DMA transactions																											

6.1.13.3.1.9 DIN_SW_RESET

Address offset: 0xC44

Reset the DIN DMA engine.

Bit number	31	30	29	28	27	26	25	24	23	22	21	20	19	18	17	16	15	14	13	12	11	10	9	8	7	6	5	4	3	2	1	0
ID	A																															
Reset 0x00000000	0																															
ID	R/W	Field	Value ID	Value	Description																											
A	W	RESET			Writing any value to this address resets the DIN DMA engine. The reset takes 4 CPU clock cycles to complete.																											
			Enable	1	Reset DIN DMA engine.																											

6.1.13.3.1.10 DIN_CPU_DATA

Address offset: 0xC48

Specifies the number of bytes the CPU will write to the DIN_BUFFER, ensuring the cryptographic engine processes the correct amount of data.

Bit number	31 30 29 28 27 26 25 24 23 22 21 20 19 18 17 16 15 14 13 12 11 10 9 8 7 6 5 4 3 2 1 0																														
ID	A A																														
Reset 0x00000000	0 0																														
ID	R/W	Field	Value ID	Value	Description																										
A	W	SIZE			When using CPU direct write to the DIN_BUFFER, the size of input data in bytes should be written to this register.																										

6.1.13.3.1.11 DIN_WRITE_ALIGN

Address offset: 0xC4C

Indicates that the next CPU write to the DIN_BUFFER is the last in the sequence. This is needed only when the data size is NOT modulo 4 (e.g. HASH padding).

Bit number	31 30 29 28 27 26 25 24 23 22 21 20 19 18 17 16 15 14 13 12 11 10 9 8 7 6 5 4 3 2 1 0																														
ID	A																														
Reset 0x00000000	0 0																														
ID	R/W	Field	Value ID	Value	Description																										
A	W	LAST			Next CPU write to the DIN_BUFFER is the last word.																										
			Confirm	1	The next CPU write is the last in the sequence.																										

6.1.13.3.1.12 DIN_FIFO_EMPTY

Address offset: 0xC50

Register indicating if DIN FIFO is empty and if more data can be accepted.

Bit number	31 30 29 28 27 26 25 24 23 22 21 20 19 18 17 16 15 14 13 12 11 10 9 8 7 6 5 4 3 2 1 0																														
ID	A																														
Reset 0x00000001	0 1																														
ID	R/W	Field	Value ID	Value	Description																										
A	R	STATUS			DIN FIFO status																										
			NotEmpty	0	DIN FIFO is not empty																										
			Empty	1	DIN FIFO is empty, and more data can be accepted																										

6.1.13.3.1.13 DIN_FIFO_RESET

Address offset: 0xC58

Reset the DIN FIFO, effectively clearing the FIFO for new data.

Bit number	31 30 29 28 27 26 25 24 23 22 21 20 19 18 17 16 15 14 13 12 11 10 9 8 7 6 5 4 3 2 1 0																														
ID	A																														
Reset 0x00000000	0 0																														
ID	R/W	Field	Value ID	Value	Description																										
A	W	RESET			Writing any value to this address resets the DIN FIFO.																										
			Enable	1	Reset DIN FIFO.																										

6.1.13.4 DOUT DMA engine

The Data OUT (DOUT) DMA engine transfers data from the CRYPTOCELL subsystem and its various cryptographic engines.

The DOUT DMA engine provides a comprehensive interface for to facilitate the transfer of data to the CPU or memory from the cryptographic engines. It includes a variety of registers that control direct data buffering, DMA operations, and data flow management.

Maximum DMA transaction size is limited to $2^{16}-1$ bytes. If a DMA transaction is configured with a payload size above the maximum DMA transaction size limit, the DMA engine must be reset before being functional again using register [DOUT_SW_RESET](#) on page 144.

The flow demonstrated in [Cryptographic flow](#) on page 93 shows how the DOUT DMA engine is configured to output data from the AES engine using registers [DST_MEM_ADDR](#) on page 142 and [DST_MEM_SIZE](#) on page 142 to define the output source address and number of output bytes, respectively.

6.1.13.4.1 Registers

Instances

Instance	Base address	TrustZone			Split access	Description
		Map	Att	DMA		
CC_DOUT	0x50841000	HF	S	NSA	No	CRYPTOCELL DOUT DMA engine

Register overview

Register	Offset	TZ	Description
DOUT_BUFFER	0xC00		Cryptographic results directly accessible by the CPU.
DOUT_DMA_MEM_BUSY	0xD20		Status register for DOUT DMA engine activity when accessing memory.
DST_MEM_ADDR	0xD28		Data destination address in memory.
DST_MEM_SIZE	0xD2C		The number of bytes to be written to memory.
DST_SRAM_ADDR	0xD30		Data destination address in RNG SRAM.
DST_SRAM_SIZE	0xD34		The number of bytes to be written to RNG SRAM.
DOUT_DMA_SRAM_BUSY	0xD38		Status register for DOUT DMA engine activity when accessing RNG SRAM.
DOUT_DMA_SRAM_ENDIANNESS	0xD3C		Configure the endianness of DOUT DMA transactions towards RNG SRAM.
DOUT_READ_ALIGN	0xD44		Indication that the next CPU read from the DOUT_BUFFER is the last in the sequence. This is needed only when the data size is NOT modulo 4 (e.g. HASH padding).
DOUT_FIFO_EMPTY	0xD50		Register indicating if DOUT FIFO is empty or if more data will come.
DOUT_SW_RESET	0xD58		Reset the DOUT DMA engine.

6.1.13.4.1.1 DOUT_BUFFER

Address offset: 0xC00

Cryptographic results directly accessible by the CPU.

Bit number	31	30	29	28	27	26	25	24	23	22	21	20	19	18	17	16	15	14	13	12	11	10	9	8	7	6	5	4	3	2	1	0
ID	A	A	A	A	A	A	A	A	A	A	A	A	A	A	A	A	A	A	A	A	A	A	A	A	A	A	A	A	A	A	A	A
Reset 0x00000000	0	0	0	0	0	0	0	0	0	0	0	0	0	0	0	0	0	0	0	0	0	0	0	0	0	0	0	0	0	0	0	0
ID	R/W	Field	Value	ID	Value	Description																										
A	R	DATA				This address can be used by the CPU to read data directly from the DOUT buffer.																										

6.1.13.4.1.2 DOUT_DMA_MEM_BUSY

Address offset: 0xD20

Status register for DOUT DMA engine activity when accessing memory.

Bit number	31 30 29 28 27 26 25 24 23 22 21 20 19 18 17 16 15 14 13 12 11 10 9 8 7 6 5 4 3 2 1 0																														
ID	A																														
Reset	0x00000000																														
	0 0																														
ID	R/W	Field	Value ID	Value	Description																										
A	R	STATUS			DOUT memory DMA engine status.																										
			Idle	0	DOUT memory DMA engine is idle																										
			Busy	1	DOUT memory DMA engine is busy																										

6.1.13.4.1.3 DST_MEM_ADDR

Address offset: 0xD28

Data destination address in memory.

Bit number	31 30 29 28 27 26 25 24 23 22 21 20 19 18 17 16 15 14 13 12 11 10 9 8 7 6 5 4 3 2 1 0																														
ID	A A																														
Reset	0x00000000																														
	0 0																														
ID	R/W	Field	Value ID	Value	Description																										
A	W	ADDR			Destination address in memory.																										

6.1.13.4.1.4 DST_MEM_SIZE

Address offset: 0xD2C

The number of bytes to be written to memory.

Bit number	31 30 29 28 27 26 25 24 23 22 21 20 19 18 17 16 15 14 13 12 11 10 9 8 7 6 5 4 3 2 1 0																														
ID	C B A																														
Reset	0x00000000																														
	0 0																														
ID	R/W	Field	Value ID	Value	Description																										
A	W	SIZE			Total number of bytes to write to memory.																										
B	W	FIRST			This field is reserved																										
C	W	LAST			This field is reserved																										

6.1.13.4.1.5 DST_SRAM_ADDR

Address offset: 0xD30

Data destination address in RNG SRAM.

Bit number	31 30 29 28 27 26 25 24 23 22 21 20 19 18 17 16 15 14 13 12 11 10 9 8 7 6 5 4 3 2 1 0																														
ID	A A																														
Reset	0x00000000																														
	0 0																														
ID	R/W	Field	Value ID	Value	Description																										
A	RW	ADDR			Destination address in RNG SRAM.																										

6.1.13.4.1.6 DST_SRAM_SIZE

Address offset: 0xD34

The number of bytes to be written to RNG SRAM.

Bit number	31	30	29	28	27	26	25	24	23	22	21	20	19	18	17	16	15	14	13	12	11	10	9	8	7	6	5	4	3	2	1	0
ID	A																															
Reset 0x00000000	0																															
ID	R/W	Field	Value ID	Value	Description																											
A	W	SIZE			Total number of bytes to write to RNG SRAM.																											

6.1.13.4.1.7 DOUT_DMA_SRAM_BUSY

Address offset: 0xD38

Status register for DOUT DMA engine activity when accessing RNG SRAM.

Bit number	31	30	29	28	27	26	25	24	23	22	21	20	19	18	17	16	15	14	13	12	11	10	9	8	7	6	5	4	3	2	1	0
ID																																A
Reset 0x00000000	0																															
ID	R/W	Field	Value ID	Value	Description																											
A	R	STATUS			DOUT RNG SRAM DMA engine status.																											
			Idle	0	DOUT RNG SRAM DMA engine is idle																											
			Busy	1	DOUT RNG SRAM DMA engine is busy																											

6.1.13.4.1.8 DOUT_DMA_SRAM_ENDIANNES

Address offset: 0xD3C

Configure the endianness of DOUT DMA transactions towards RNG SRAM.

Bit number	31	30	29	28	27	26	25	24	23	22	21	20	19	18	17	16	15	14	13	12	11	10	9	8	7	6	5	4	3	2	1	0
ID																																A
Reset 0x00000000	0																															
ID	R/W	Field	Value ID	Value	Description																											
A	RW	ENDIAN			Endianness of DOUT DMA transactions towards RNG SRAM. The default value is little-endian.																											
			LittleEndian	0	Use little-endian format for RNG SRAM DMA transactions																											
			BigEndian	1	Use big-endian format for RNG SRAM DMA transactions																											

6.1.13.4.1.9 DOUT_READ_ALIGN

Address offset: 0xD44

Indication that the next CPU read from the DOUT_BUFFER is the last in the sequence. This is needed only when the data size is NOT modulo 4 (e.g. HASH padding).

Bit number	31	30	29	28	27	26	25	24	23	22	21	20	19	18	17	16	15	14	13	12	11	10	9	8	7	6	5	4	3	2	1	0
ID																																A
Reset 0x00000000	0																															
ID	R/W	Field	Value ID	Value	Description																											
A	W	LAST			Next CPU read from the DOUT_BUFFER is the last word, and the remaining read aligned content can be flushed.																											
			Flush	1	Flush the remaining read aligned content.																											

6.1.13.4.1.10 DOUT_FIFO_EMPTY

Address offset: 0xD50

Register indicating if DOUT FIFO is empty or if more data will come.

Bit number	31	30	29	28	27	26	25	24	23	22	21	20	19	18	17	16	15	14	13	12	11	10	9	8	7	6	5	4	3	2	1	0
ID																																A
Reset 0x00000001	0 1																															
ID	R/W	Field	Value ID	Value	Description																											
A	R	STATUS			DOUT FIFO status																											
			NotEmpty	0	DOUT FIFO is not empty, and more data will come																											
			Empty	1	DOUT FIFO is empty																											

6.1.13.4.1.11 DOUT_SW_RESET

Address offset: 0xD58

Reset the DOUT DMA engine.

Bit number	31	30	29	28	27	26	25	24	23	22	21	20	19	18	17	16	15	14	13	12	11	10	9	8	7	6	5	4	3	2	1	0
ID																																A
Reset 0x00000000	0 0																															
ID	R/W	Field	Value ID	Value	Description																											
A	W	RESET			Writing any value to this address resets the DOUT DMA engine. The reset takes 4 CPU clock cycles to complete.																											
			Enable	1	Reset DOUT DMA engine.																											

6.1.13.5 HOST register interface

The HOST_RGF interface contains registers for CRYPTOCELL interrupt handling, configuring CRYPTOCELL lifecycle state and CRYPTOCELL key management where different cryptographic key inputs can be connected to the AES engine.

Use of the CRYPTOCELL K_{PRTL} key or the device root key K_{DR} is selected using this interface. Availability and configuration of these two key types are typically controlled from an immutable bootloader. Once CRYPTOCELL has been correctly configured it will be possible for an application to either use session keys directly or perform cryptographic operations with the device root key K_{DR} without having access to the key value.

6.1.13.5.1 Registers

Instances

Instance	Base address	TrustZone			Split access	Description
		Map	Att	DMA		
CC_HOST_RGF	0x50841000	HF	S	NSA	No	CRYPTOCELL HOST register interface

Register overview

Register	Offset	TZ	Description
IRR	0xA00		Interrupt request register. Each bit of this register holds the interrupt status of a single interrupt source. If corresponding IMR bit is unmasked, an interrupt is generated.
IMR	0xA04		Interrupt mask register. Each bit of this register holds the mask of a single interrupt source.
ICR	0xA08		Interrupt clear register. Writing a 1 bit into a field in this register will clear the corresponding bit in IRR.
ENDIANNESS	0xA0C		This register defines the endianness of the Host-accessible registers, and can only be written once.
HOST_SIGNATURE	0xA24		This register holds the CRYPTOCELL subsystem signature. See reset value.

Register	Offset	TZ	Description
HOST_BOOT	0xA28		Hardware configuration of the CRYPTOCELL subsystem. Reset value holds the supported features.
HOST_CRYPTKEY_SEL	0xA38		AES hardware key select.
HOST_IOT_KPRTL_LOCK	0xA4C		This write-once register is the K_PRTL lock register. When this register is set, K_PRTL cannot be used and a zeroed key will be used instead. The value of this register is saved in the CRYPTOCELL AO power domain.
HOST_IOT_KDR0	0xA50		This register holds bits 31:0 of K_DR. The value of this register is saved in the CRYPTOCELL AO power domain. Reading from this address returns the K_DR valid status indicating if K_DR is successfully retained.
HOST_IOT_KDR1	0xA54		This register holds bits 63:32 of K_DR. The value of this register is saved in the CRYPTOCELL AO power domain.
HOST_IOT_KDR2	0xA58		This register holds bits 95:64 of K_DR. The value of this register is saved in the CRYPTOCELL AO power domain.
HOST_IOT_KDR3	0xA5C		This register holds bits 127:96 of K_DR. The value of this register is saved in the CRYPTOCELL AO power domain.
HOST_IOT_LCS	0xA60		Controls life-cycle state (LCS) for CRYPTOCELL subsystem

6.1.13.5.1.1 IRR

Address offset: 0xA00

Interrupt request register. Each bit of this register holds the interrupt status of a single interrupt source. If corresponding IMR bit is unmasked, an interrupt is generated.

Bit number	31 30 29 28 27 26 25 24 23 22 21 20 19 18 17 16 15 14 13 12 11 10 9 8 7 6 5 4 3 2 1 0																														
ID	G F E D C B A																														
Reset 0x00000000	0 0																														
ID	R/W	Field	Value ID	Value	Description																										
A	R	SRAM_TO_DIN_INT			The RNG SRAM to DIN DMA done interrupt status. This interrupt is asserted when all data was delivered from RNG SRAM to DIN buffer.																										
B	R	DOUT_TO_SRAM_INT			The DOUT to RNG SRAM DMA done interrupt status. This interrupt is asserted when all data was delivered from DOUT buffer to RNG SRAM.																										
C	R	MEM_TO_DIN_INT			The memory to DIN DMA done interrupt status. This interrupt is asserted when all data was delivered from memory to DIN buffer.																										
D	R	DOUT_TO_MEM_INT			The DOUT to memory DMA done interrupt status. This interrupt is asserted when all data was delivered from DOUT buffer to memory.																										
E	R	AHB_ERR_INT			The AHB error interrupt status.																										
F	R	PKA_INT			The PKA end of operation interrupt status.																										
G	R	RNG_INT			The RNG interrupt status.																										

6.1.13.5.1.2 IMR

Address offset: 0xA04

Interrupt mask register. Each bit of this register holds the mask of a single interrupt source.

Bit number	31 30 29 28 27 26 25 24 23 22 21 20 19 18 17 16 15 14 13 12 11 10 9 8 7 6 5 4 3 2 1 0																														
ID	G F E D C B A																														
Reset 0x01FFFFFF	0 0 0 0 0 0 0 0 1																														
ID	R/W	Field	Value ID	Value	Description																										
A	RW	SRAM_TO_DIN_MASK			The RNG SRAM to DIN DMA done interrupt mask.																										
			IRQEnable	0	Do not mask RNG SRAM to DIN DMA done interrupt i.e. interrupt is generated																										
			IRQDisable	1	Mask RNG SRAM to DIN DMA done interrupt i.e. no interrupt is generated																										

Bit number	31 30 29 28 27 26 25 24 23 22 21 20 19 18 17 16 15 14 13 12 11 10 9 8 7 6 5 4 3 2 1 0																														
ID	G F E D C B A																														
Reset 0x01FFFFFF	0 0 0 0 0 0 0 0 1																														
ID	R/W	Field	Value ID	Value	Description																										
B	RW	DOUT_TO_SRAM_MASK			The DOUT to RNG SRAM DMA done interrupt mask.																										
			IRQEnable	0	Do not mask DOUT to RNG SRAM DMA done interrupt i.e. interrupt is generated																										
			IRQDisable	1	Mask DOUT to RNG SRAM DMA done interrupt i.e. no interrupt is generated																										
C	RW	MEM_TO_DIN_MASK			The memory to DIN DMA done interrupt mask.																										
			IRQEnable	0	Do not mask memory to DIN DMA done interrupt i.e. interrupt is generated																										
			IRQDisable	1	Mask memory to DIN DMA done interrupt i.e. no interrupt is generated																										
D	RW	DOUT_TO_MEM_MASK			The DOUT to memory DMA done interrupt mask.																										
			IRQEnable	0	Do not mask DOUT to memory DMA done interrupt i.e. interrupt is generated																										
			IRQDisable	1	Mask DOUT to memory DMA done interrupt i.e. no interrupt is generated																										
E	RW	AHB_ERR_MASK			The AHB error interrupt mask.																										
			IRQEnable	0	Do not mask AHB error interrupt i.e. interrupt is generated																										
			IRQDisable	1	Mask AHB error interrupt i.e. no interrupt is generated																										
F	RW	PKA_MASK			The PKA end of operation interrupt mask.																										
			IRQEnable	0	Do not mask PKA end of operation interrupt i.e. interrupt is generated																										
			IRQDisable	1	Mask PKA end of operation interrupt i.e. no interrupt is generated																										
G	RW	RNG_MASK			The RNG interrupt mask.																										
			IRQEnable	0	Do not mask RNG interrupt i.e. interrupt is generated																										
			IRQDisable	1	Mask RNG interrupt i.e. no interrupt is generated																										

6.1.13.5.1.3 ICR

Address offset: 0xA08

Interrupt clear register. Writing a 1 bit into a field in this register will clear the corresponding bit in IRR.

Bit number	31 30 29 28 27 26 25 24 23 22 21 20 19 18 17 16 15 14 13 12 11 10 9 8 7 6 5 4 3 2 1 0																														
ID	G F E D C B A																														
Reset 0x00000000	0 0																														
ID	R/W	Field	Value ID	Value	Description																										
A	W	SRAM_TO_DIN_CLEAR			The RNG SRAM to DIN DMA done interrupt clear.																										
B	W	DOUT_TO_SRAM_CLEAR			The DOUT to RNG SRAM DMA done interrupt clear.																										
C	W	MEM_TO_DIN_CLEAR			The memory to DIN DMA done interrupt clear.																										
D	W	DOUT_TO_MEM_CLEAR			The DOUT to memory DMA done interrupt clear.																										
E	W	AHB_ERR_CLEAR			The AHB error interrupt clear.																										
F	W	PKA_CLEAR			The PKA end of operation interrupt clear.																										
G	W	RNG_CLEAR			The RNG interrupt clear. Register RNG_ISR in the RNG engine must be cleared before this interrupt can be cleared.																										

6.1.13.5.1.4 ENDIANNESS

Address offset: 0xA0C

This register defines the endianness of the Host-accessible registers, and can only be written once.

Bit number	31 30 29 28 27 26 25 24 23 22 21 20 19 18 17 16 15 14 13 12 11 10 9 8 7 6 5 4 3 2 1 0																														
ID	D C B A																														
Reset 0x00000000	0 0																														
ID	R/W	Field	Value ID	Value	Description																										
A	RW	DOUT_WR_BG			DOUT write endianness.																										

Bit number	31 30 29 28 27 26 25 24 23 22 21 20 19 18 17 16 15 14 13 12 11 10 9 8 7 6 5 4 3 2 1 0																														
ID	D															C					B					A					
Reset 0x00000000	0 0																														
ID	R/W	Field	Value ID	Value	Description																										
			LittleEndian	0	Configure DOUT write as little-endian																										
			BigEndian	1	Configure DOUT write as big-endian																										
B	RW	DIN_RD_BG			DIN read endianness.																										
			LittleEndian	0	Configure DIN read as little-endian																										
			BigEndian	1	Configure DIN read as big-endian																										
C	RW	DOUT_WR_WBG			DOUT write word endianness.																										
			LittleEndian	0	Configure DOUT write word as little-endian																										
			BigEndian	1	Configure DOUT write word as big-endian																										
D	RW	DIN_RD_WBG			DIN read word endianness.																										
			LittleEndian	0	Configure DIN read word as little-endian																										
			BigEndian	1	Configure DIN read word as big-endian																										

6.1.13.5.1.5 HOST_SIGNATURE

Address offset: 0xA24

This register holds the CRYPTOCELL subsystem signature. See reset value.

Bit number	31 30 29 28 27 26 25 24 23 22 21 20 19 18 17 16 15 14 13 12 11 10 9 8 7 6 5 4 3 2 1 0																														
ID	A A																														
Reset 0x20E00000	0 0 1 0 0 0 0 0 1 1 1 0																														
ID	R/W	Field	Value ID	Value	Description																										
A	R	VALUE			Fixed-value identification signature used by host driver to verify CRYPTOCELL presence at this address.																										

6.1.13.5.1.6 HOST_BOOT

Address offset: 0xA28

Hardware configuration of the CRYPTOCELL subsystem. Reset value holds the supported features.

Bit number	31 30 29 28 27 26 25 24 23 22 21 20 19 18 17 16 15 14 13 12 11 10 9 8 7 6 5 4 3 2 1 0																														
ID	b a Z Y X W V U T S R Q P O N M L K J I H G F F F E D C B A																														
Reset 0x4622982C	0 1 0 0 0 1 1 0 0 0 1 0 0 0 1 0 1 0 0 1 1 0 0 0 0 0 1 0 1 1 0 0																														
ID	R/W	Field	Value ID	Value	Description																										
A	R	POWER_GATING_EXISTS_LOCAL			If this flag is set, full power gating is implemented																										
B	R	LARGE_RKEK_LOCAL			If this flag is set, large RKEK is supported																										
C	R	HASH_IN_FUSES_LOCAL			If this flag is set, HASH in fuses is supported																										
D	R	EXT_MEM_SECURED_LOCAL			If this flag is set, external secure memory is supported																										
E	R	RKEK_ECC_EXISTS_LOCAL_N			If this flag is set, RKEK ECC is supported																										
F	R	SRAM_SIZE_LOCAL			SRAM size																										
G	R	DSCRPTR_EXISTS_LOCAL			If this flag is set, Descriptors are supported																										
H	R	PAU_EXISTS_LOCAL			If this flag is set, PAU is supported																										
I	R	RNG_EXISTS_LOCAL			If this flag is set, the RNG engine is present																										
J	R	PKA_EXISTS_LOCAL			If this flag is set, the PKA engine is present																										
K	R	RC4_EXISTS_LOCAL			If this flag is set, the RC4 engine is present																										
L	R	SHA_512_PRSN_LOCAL			If this flag is set, the HASH engine supports SHA512																										
M	R	SHA_256_PRSN_LOCAL			If this flag is set, the HASH engine supports SHA256																										
N	R	MD5_PRSN_LOCAL			If this flag is set, the HASH engine supports MD5																										
O	R	HASH_EXISTS_LOCAL			If this flag is set, the HASH engine is present																										
P	R	C2_EXISTS_LOCAL			If this flag is set, the C2 engine is present																										

Bit number	31 30 29 28 27 26 25 24 23 22 21 20 19 18 17 16 15 14 13 12 11 10 9 8 7 6 5 4 3 2 1 0																														
ID	b a Z Y X W V U T S R Q P O N M L K J I H G F F F E D C B A																														
Reset 0x4622982C	0 1 0 0 0 1 1 0 0 0 1 0 0 0 1 0 1 0 0 1 1 0 0 0 0 0 1 0 1 1 0 0																														
ID	R/W	Field	Value ID	Value	Description																										
Q	R	DES_EXISTS_LOCAL			If this flag is set, the DES engine is present																										
R	R	AES_XCBC_MAC_EXISTS_LOCAL			If this flag is set, AES XCBC-MAC mode is supported																										
S	R	AES_CMAC_EXISTS_LOCAL			If this flag is set, AES CMAC mode is supported																										
T	R	AES_CCM_EXISTS_LOCAL			If this flag is set, AES CCM mode is supported																										
U	R	AES_XEX_HW_T_CALC_LOCAL			If this flag is set, AES XEX mode T-value calculation in HW is supported																										
V	R	AES_XEX_EXISTS_LOCAL			If this flag is set, AES XEX mode is supported																										
W	R	CTR_EXISTS_LOCAL			If this flag is set, AES CTR mode is supported																										
X	R	AES_DIN_BYTE_RESOLUTION_LOCAL			If this flag is set, the AES engine data input support byte size resolution																										
Y	R	TUNNELING_ENB_LOCAL			If this flag is set, the AES engine supports tunneling operations																										
Z	R	SUPPORT_256_192_KEY_LOCAL			If this flag is set, the AES engine supports 192/256 bits key sizes																										
a	R	ONLY_ENCRYPT_LOCAL			If this flag is set, the AES engine only support encryption																										
b	R	AES_EXISTS_LOCAL			If this flag is set, the AES engine is present																										

6.1.13.5.1.7 HOST_CRYPTKEY_SEL

Address offset: 0xA38

AES hardware key select.

If the HOST_IOT_KPRTL_LOCK register is set, and the HOST_CRYPTKEY_SEL register set to 1, then the HW key that is connected to the AES engine is zero

Bit number	31 30 29 28 27 26 25 24 23 22 21 20 19 18 17 16 15 14 13 12 11 10 9 8 7 6 5 4 3 2 1 0																														
ID	A A																														
Reset 0x00000000	0 0																														
ID	R/W	Field	Value ID	Value	Description																										
A	RW	HOST_CRYPTKEY_SEL			Select the source of the HW key that is used by the AES engine																										
			K_DR	0	Use device root key K_DR from CRYPTOCELL AO power domain																										
			K_PRTL	1	Use hard-coded RTL key K_PRTL																										
			Session	2	Use provided session key																										

6.1.13.5.1.8 HOST_IOT_KPRTL_LOCK

Address offset: 0xA4C

This write-once register is the K_PRTL lock register. When this register is set, K_PRTL cannot be used and a zeroed key will be used instead. The value of this register is saved in the CRYPTOCELL AO power domain.

Bit number	31 30 29 28 27 26 25 24 23 22 21 20 19 18 17 16 15 14 13 12 11 10 9 8 7 6 5 4 3 2 1 0																														
ID	A																														
Reset 0x00000000	0 0																														
ID	R/W	Field	Value ID	Value	Description																										
A	RW1	HOST_IOT_KPRTL_LOCK			This register is the K_PRTL lock register. When this register is set, K_PRTL cannot be used and a zeroed key will be used instead. The value of this register is saved in the CRYPTOCELL AO power domain.																										
			Disabled	0	K_PRTL can be selected for use from register HOST_CRYPTKEY_SEL																										
			Enabled	1	K_PRTL has been locked until next power-on reset (POR). If K_PRTL is selected anyway, a zeroed key will be used instead.																										

6.1.13.5.1.9 HOST_IOT_KDR0

Address offset: 0xA50

This register holds bits 31:0 of K_DR. The value of this register is saved in the CRYPTOCELL AO power domain. Reading from this address returns the K_DR valid status indicating if K_DR is successfully retained.

Bit number	31	30	29	28	27	26	25	24	23	22	21	20	19	18	17	16	15	14	13	12	11	10	9	8	7	6	5	4	3	2	1	0
ID	A	A	A	A	A	A	A	A	A	A	A	A	A	A	A	A	A	A	A	A	A	A	A	A	A	A	A	A	A	A	A	A
Reset 0x00000000	0	0	0	0	0	0	0	0	0	0	0	0	0	0	0	0	0	0	0	0	0	0	0	0	0	0	0	0	0	0	0	
ID	R/W	Field	Value ID	Value	Description																											
A	RW1	HOST_IOT_KDR0			This register holds bits 31:0 of K_DR. The value of this register is saved in the CRYPTOCELL AO power domain. Reading from this address returns the K_DR valid status indicating if K_DR is successfully retained.																											
			NotRetained	0	Write: K_DR bits 31:0. Read: 128 bits K_DR key value is not yet retained in the CRYPTOCELL AO power domain.																											
			Retained	1	Read: 128 bits K_DR key value is successfully retained in the CRYPTOCELL AO power domain.																											

6.1.13.5.1.10 HOST_IOT_KDR1

Address offset: 0xA54

This register holds bits 63:32 of K_DR. The value of this register is saved in the CRYPTOCELL AO power domain.

Bit number	31	30	29	28	27	26	25	24	23	22	21	20	19	18	17	16	15	14	13	12	11	10	9	8	7	6	5	4	3	2	1	0
ID	A	A	A	A	A	A	A	A	A	A	A	A	A	A	A	A	A	A	A	A	A	A	A	A	A	A	A	A	A	A	A	
Reset 0x00000000	0	0	0	0	0	0	0	0	0	0	0	0	0	0	0	0	0	0	0	0	0	0	0	0	0	0	0	0	0	0	0	
ID	R/W	Field	Value ID	Value	Description																											
A	W1	HOST_IOT_KDR1			K_DR bits 63:32																											

6.1.13.5.1.11 HOST_IOT_KDR2

Address offset: 0xA58

This register holds bits 95:64 of K_DR. The value of this register is saved in the CRYPTOCELL AO power domain.

Bit number	31	30	29	28	27	26	25	24	23	22	21	20	19	18	17	16	15	14	13	12	11	10	9	8	7	6	5	4	3	2	1	0
ID	A	A	A	A	A	A	A	A	A	A	A	A	A	A	A	A	A	A	A	A	A	A	A	A	A	A	A	A	A	A	A	
Reset 0x00000000	0	0	0	0	0	0	0	0	0	0	0	0	0	0	0	0	0	0	0	0	0	0	0	0	0	0	0	0	0	0	0	
ID	R/W	Field	Value ID	Value	Description																											
A	W1	HOST_IOT_KDR2			K_DR bits 95:64																											

6.1.13.5.1.12 HOST_IOT_KDR3

Address offset: 0xA5C

This register holds bits 127:96 of K_DR. The value of this register is saved in the CRYPTOCELL AO power domain.

Bit number	31	30	29	28	27	26	25	24	23	22	21	20	19	18	17	16	15	14	13	12	11	10	9	8	7	6	5	4	3	2	1	0
ID	A	A	A	A	A	A	A	A	A	A	A	A	A	A	A	A	A	A	A	A	A	A	A	A	A	A	A	A	A	A	A	
Reset 0x00000000	0	0	0	0	0	0	0	0	0	0	0	0	0	0	0	0	0	0	0	0	0	0	0	0	0	0	0	0	0	0	0	
ID	R/W	Field	Value ID	Value	Description																											
A	W1	HOST_IOT_KDR3			K_DR bits 127:96																											

6.1.13.5.1.13 HOST_IOT_LCS

Address offset: 0xA60

Controls life-cycle state (LCS) for CRYPTOCELL subsystem

Bit number	31	30	29	28	27	26	25	24	23	22	21	20	19	18	17	16	15	14	13	12	11	10	9	8	7	6	5	4	3	2	1	0
ID																								B	A			A	A			
Reset 0x00000002	0 1 0																															
ID	R/W	Field	Value ID	Value	Description																											
A	RW1	LCS			Life-cycle state value. This field is write-once per reset.																											
			DebugEnable	0	CC310 operates in debug mode																											
			Secure	2	CC310 operates in secure mode																											
B	R	LCS_IS_VALID			Read-only field. Indicates if CRYPTOCELL LCS has been successfully configured since last reset.																											
			Invalid	0	Valid LCS not yet retained in the CRYPTOCELL AO power domain																											
			Valid	1	Valid LCS successfully retained in the CRYPTOCELL AO power domain																											

6.1.13.6 RNG SRAM interface

The RNG_SRAM interface enable reading and writing data to RNG SRAM.

6.1.13.6.1 Registers

Instances

Instance	Base address	TrustZone			Split access	Description
		Map	Att	DMA		
CC_RNG_SRAM	0x50841000	HF	S	NSA	No	CRYPTOCELL RNG SRAM interface

Register overview

Register	Offset	TZ	Description
SRAM_DATA	0xF00		Read/Write data from RNG SRAM
SRAM_ADDR	0xF04		First address given to RNG SRAM DMA for read/write transactions from/to RNG SRAM.
SRAM_DATA_READY	0xF08		RNG SRAM DMA engine is ready to read/write from/to RNG SRAM.

6.1.13.6.1.1 SRAM_DATA

Address offset: 0xF00

Read/Write data from RNG SRAM

Bit number	31	30	29	28	27	26	25	24	23	22	21	20	19	18	17	16	15	14	13	12	11	10	9	8	7	6	5	4	3	2	1	0
ID	A A																															
Reset 0x00000000	0 0																															
ID	R/W	Field	Value ID	Value	Description																											
A	RW	SRAM_DATA			32 bits DMA read/write from/to RNG SRAM. A 'read' or 'write' operation to this register will trigger the DMA address to be automatically incremented.																											

6.1.13.6.1.2 SRAM_ADDR

Address offset: 0xF04

First address given to RNG SRAM DMA for read/write transactions from/to RNG SRAM.

Bit number	31	30	29	28	27	26	25	24	23	22	21	20	19	18	17	16	15	14	13	12	11	10	9	8	7	6	5	4	3	2	1	0
ID	A A																															
Reset 0x00000000	0 0																															
ID	R/W	Field	Value ID	Value	Description																											
A	W	SRAM_ADDR			RNG SRAM starting address																											

6.1.13.6.1.3 SRAM_DATA_READY

Address offset: 0xF08

RNG SRAM DMA engine is ready to read/write from/to RNG SRAM.

Bit number	31	30	29	28	27	26	25	24	23	22	21	20	19	18	17	16	15	14	13	12	11	10	9	8	7	6	5	4	3	2	1	0
ID	A																															
Reset 0x00000001	0 1																															
ID	R/W	Field	Value ID	Value	Description																											
A	R	SRAM_READY			RNG SRAM DMA status.																											
			Busy	0	DMA is busy																											
			Idle	1	DMA is idle																											

6.1.13.7 MISC interface

The MISC interface controls clocks for the individual engines within the CRYPTOCELL subsystem.

Each cryptographic engine has an individual register for performing clock gating. Engine clock status is displayed in register [CLK_STATUS](#) on page 152.

Note: Clock control for the [RNG engine](#) on page 122 is handled by register [RNG_CLK](#) on page 131 and not through the MISC interface.

6.1.13.7.1 Registers

Instances

Instance	Base address	TrustZone			Split access	Description
		Map	Att	DMA		
CC_MISC	0x50841000	HF	S	NSA	No	CRYPTOCELL MISC interface

Register overview

Register	Offset	TZ	Description
AES_CLK	0x810		Clock control for the AES engine.
HASH_CLK	0x818		Clock control for the HASH engine.
PKA_CLK	0x81C		Clock control for the PKA engine.
DMA_CLK	0x820		Clock control for the DMA engines.
CLK_STATUS	0x824		CRYPTOCELL clocks status register.
CHACHA_CLK	0x858		Clock control for the CHACHA engine.

6.1.13.7.1.1 AES_CLK

Address offset: 0x810

Clock control for the AES engine.

Bit number	31	30	29	28	27	26	25	24	23	22	21	20	19	18	17	16	15	14	13	12	11	10	9	8	7	6	5	4	3	2	1	0
ID																																A
Reset 0x00000000	0 0																															
ID	R/W	Field	Value ID	Value	Description																											
A	W	ENABLE			Enables clock for the AES engine.																											
			Disable	0	Disable clock for the AES engine.																											
			Enable	1	Enable clock for the AES engine.																											

6.1.13.7.1.2 HASH_CLK

Address offset: 0x818

Clock control for the HASH engine.

Bit number	31	30	29	28	27	26	25	24	23	22	21	20	19	18	17	16	15	14	13	12	11	10	9	8	7	6	5	4	3	2	1	0
ID																																A
Reset 0x00000000	0 0																															
ID	R/W	Field	Value ID	Value	Description																											
A	W	ENABLE			Enables clock for the HASH engine.																											
			Disable	0	Disable clock for the HASH engine.																											
			Enable	1	Enable clock for the HASH engine.																											

6.1.13.7.1.3 PKA_CLK

Address offset: 0x81C

Clock control for the PKA engine.

Bit number	31	30	29	28	27	26	25	24	23	22	21	20	19	18	17	16	15	14	13	12	11	10	9	8	7	6	5	4	3	2	1	0
ID																																A
Reset 0x00000000	0 0																															
ID	R/W	Field	Value ID	Value	Description																											
A	W	ENABLE			Enables clock for the PKA engine.																											
			Disable	0	Disable clock for the PKA engine.																											
			Enable	1	Enable clock for the PKA engine.																											

6.1.13.7.1.4 DMA_CLK

Address offset: 0x820

Clock control for the DMA engines.

Bit number	31	30	29	28	27	26	25	24	23	22	21	20	19	18	17	16	15	14	13	12	11	10	9	8	7	6	5	4	3	2	1	0
ID																																A
Reset 0x00000000	0 0																															
ID	R/W	Field	Value ID	Value	Description																											
A	W	ENABLE			Enables clock for the DMA engines.																											
			Disable	0	Disable clock for the DMA engines.																											
			Enable	1	Enable clock for the DMA engines.																											

6.1.13.7.1.5 CLK_STATUS

Address offset: 0x824

CRYPTOCELL clocks status register.

Bit number		31 30 29 28 27 26 25 24 23 22 21 20 19 18 17 16 15 14 13 12 11 10 9 8 7 6 5 4 3 2 1 0																																
ID																												E	D			C	B	A
Reset		0x00000100																																
		0 1 0 0 0 0 0 0 0 0																																
ID	R/W	Field	Value ID	Value	Description																													
A	R	AES_CLK			Status of AES engine clock.																													
			Disabled	0	Clock for AES engine is disabled																													
			Enabled	1	Clock for AES engine is enabled																													
B	R	HASH_CLK			Status of HASH engine clock.																													
			Disabled	0	Clock for HASH engine is disabled																													
			Enabled	1	Clock for HASH engine is enabled																													
C	R	PKA_CLK			Status of PKA engine clock.																													
			Disabled	0	Clock for PKA engine is disabled																													
			Enabled	1	Clock for PKA engine is enabled																													
D	R	CHACHA_CLK			Status of CHACHA engine clock.																													
			Disabled	0	Clock for CHACHA engine is disabled																													
			Enabled	1	Clock for CHACHA engine is enabled																													
E	R	DMA_CLK			Status of DMA engines clock.																													
			Disabled	0	Clocks for DMA engines are disabled																													
			Enabled	1	Clocks for DMA engines are enabled																													

6.1.13.7.1.6 CHACHA_CLK

Address offset: 0x858

Clock control for the CHACHA engine.

Bit number		31 30 29 28 27 26 25 24 23 22 21 20 19 18 17 16 15 14 13 12 11 10 9 8 7 6 5 4 3 2 1 0																											
ID																												A	
Reset		0x00000000																											
		0 0																											
ID	R/W	Field	Value ID	Value	Description																								
A	W	ENABLE			Enables clock for the CHACHA engine.																								
			Disable	0	Disable clock for the CHACHA engine.																								
			Enable	1	Enable clock for the CHACHA engine.																								

6.2 DPPI - Distributed programmable peripheral interconnect

The distributed programmable peripheral interconnect (DPPI) enables peripherals to interact autonomously with each other by using tasks and events, without any intervention from the CPU. DPPI allows precise synchronization between peripherals when real-time application constraints exist and eliminates the need for CPU involvement to implement behavior which can be predefined using the DPPI.

Note: For more information on tasks, events, publish/subscribe, interrupts, and other concepts, see [Peripheral interface](#) on page 17.

The DPPI has the following features:

- Peripheral tasks can subscribe to channels
- Peripheral events can be published on channels
- Publish/subscribe pattern enabling multiple connection options that include the following:
 - One-to-one
 - One-to-many

- Many-to-one
- Many-to-many

The DPPI consists of several PPIBus modules, which are connected to a fixed number of DPPI channels and a DPPI configuration (DPPIC).

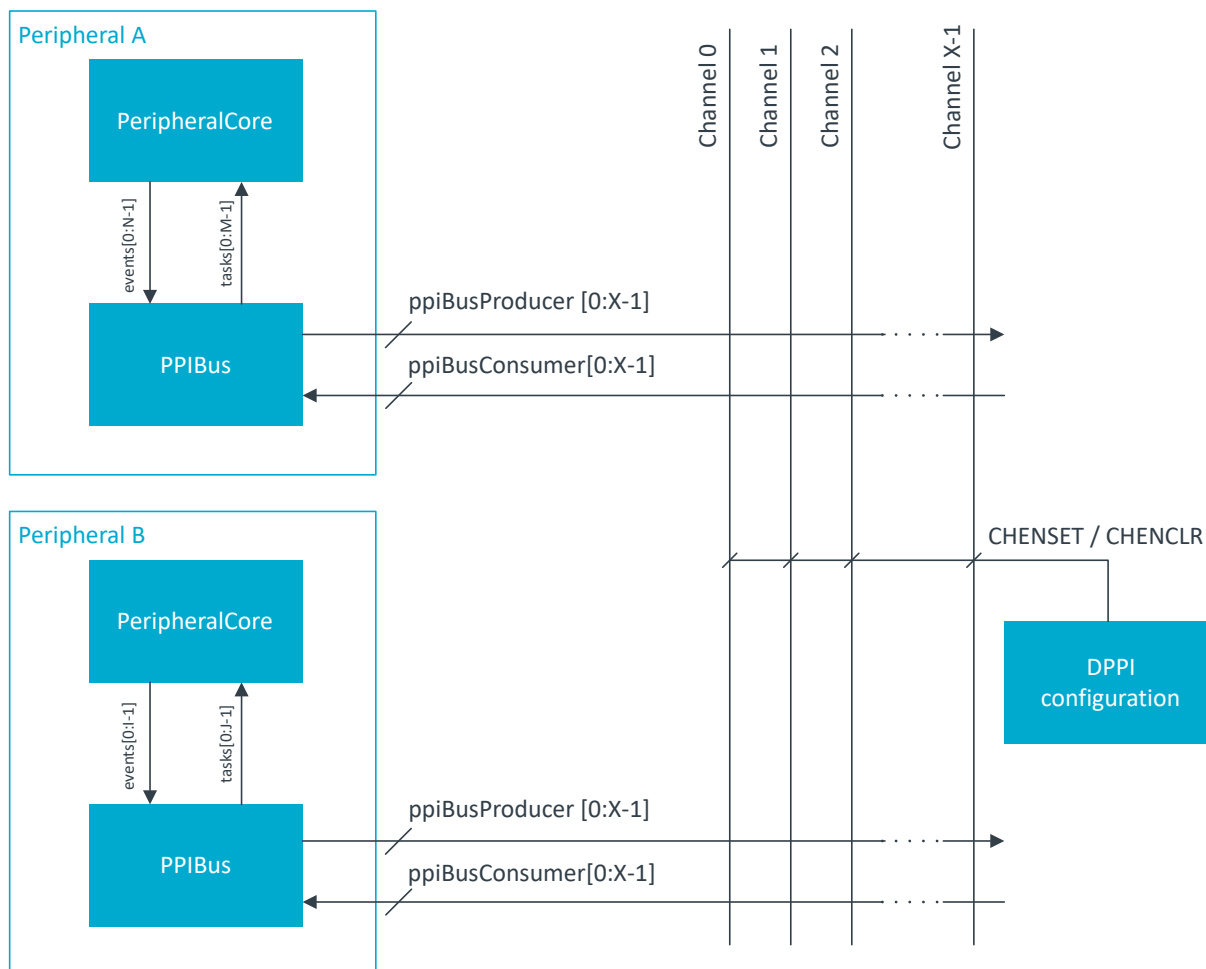

Figure 19: DPPI overview

6.2.1 Subscribing to and publishing on channels

The PPIBus can route peripheral events onto the channels (publishing), or route events from the channels into peripheral tasks (subscribing).

All peripherals include the following:

- One subscribe register per task
- One publish register per event

Publish and subscribe registers use a channel index field to determine the channel to which the event is published or tasks subscribed. In addition, there is an enable bit for the subscribe and publish registers that needs to be enabled before the subscription or publishing takes effect.

Writing non-existing channel index (CHIDX) numbers into a peripheral's publish or subscribe registers will yield unexpected results.

One event can trigger multiple tasks by subscribing different tasks to the same channel. Similarly, one task can be triggered by multiple events by publishing different events to the same channel. For advanced use cases, multiple events and multiple tasks can connect to the same channel forming a many-to-many connection. If multiple events are published on the same channel at the same time, the events are merged and only one event is routed through the DPPI.

How peripheral events are routed onto different channels based on publish registers is illustrated in the following figure.

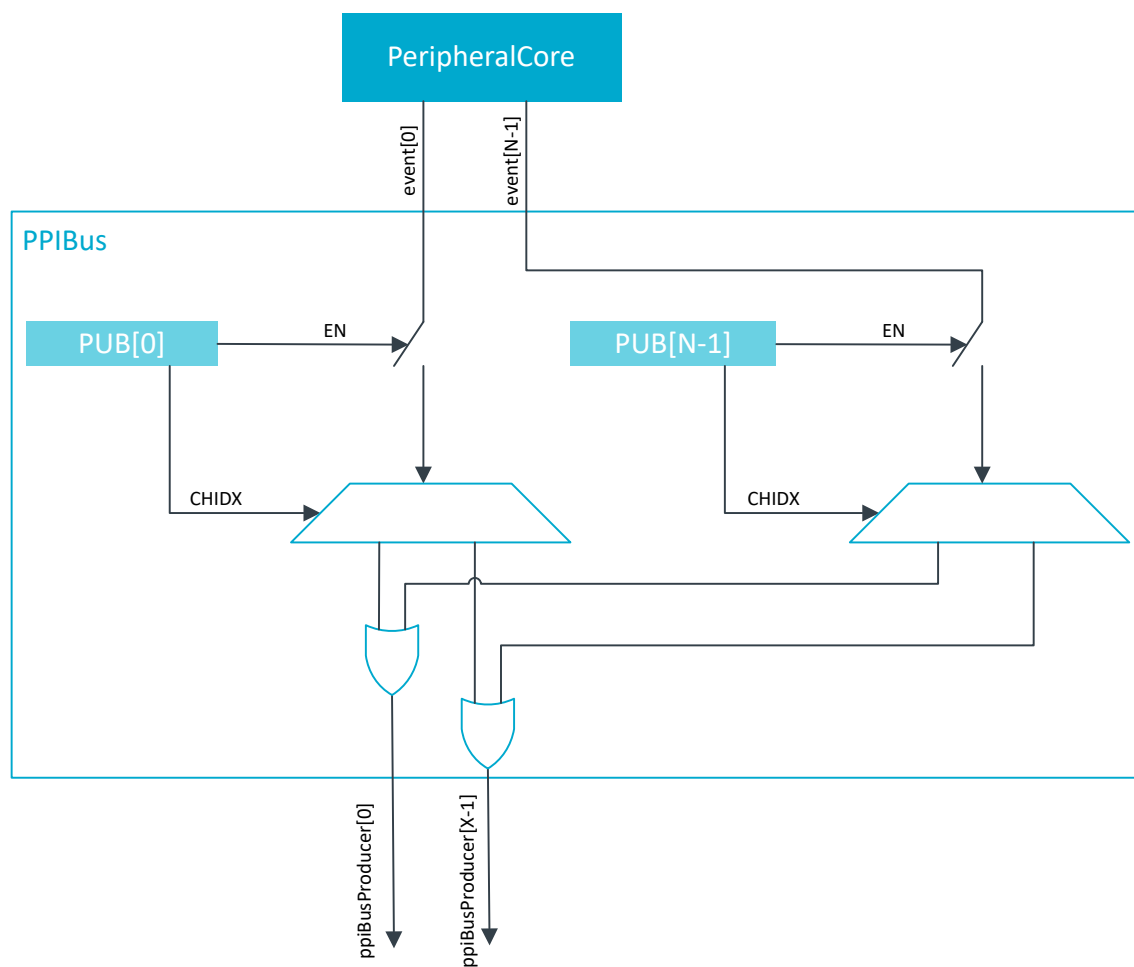

Figure 20: DPPI events flow

The following figure illustrates how peripheral tasks are triggered from different channels based on subscribe registers.

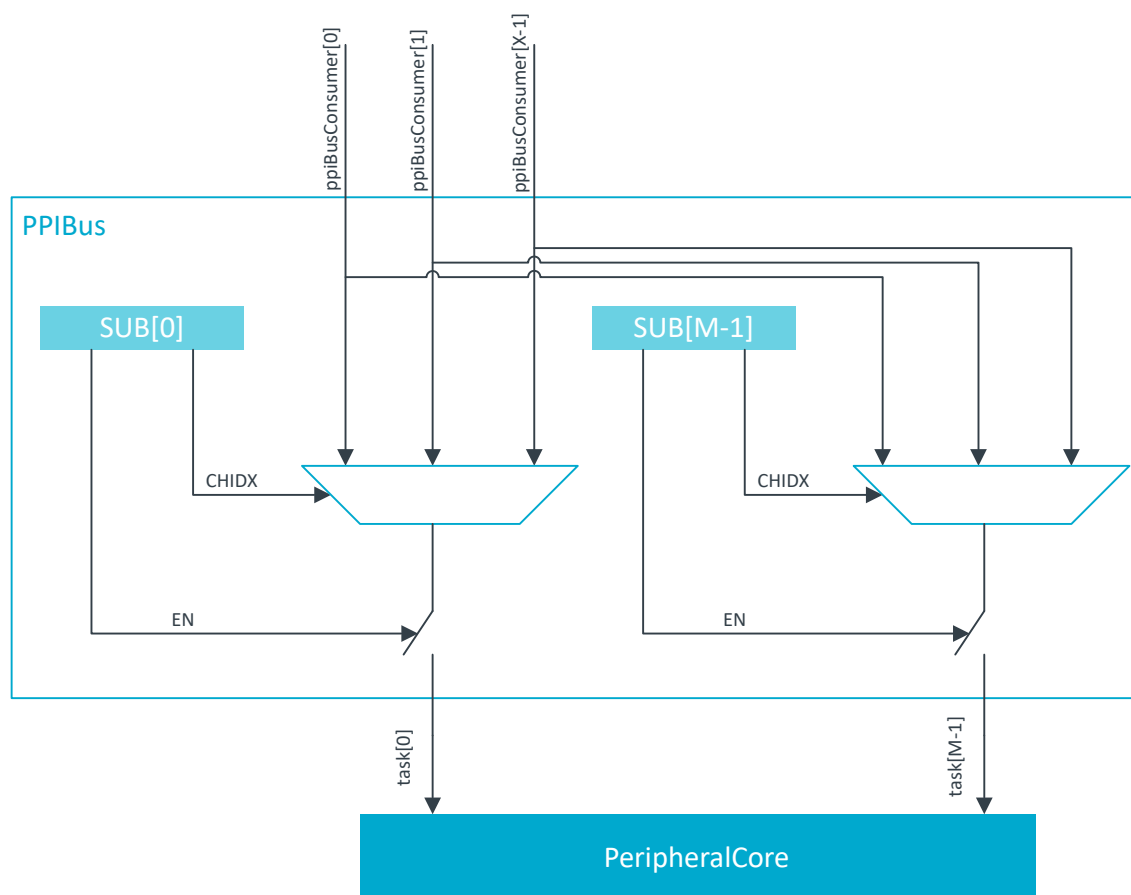

Figure 21: DPPI tasks flow

6.2.2 DPPI configuration (DPPIC)

Enabling and disabling of channels globally is handled through the DPPI configuration (DPPIC). Connection (connect/disconnect) between a channel and a peripheral is handled locally by the PPIBus.

There are two ways of enabling and disabling global channels using the DPPI configuration:

- Enable or disable channels individually using registers CHEN, CHENSET, and CHENCLR.
- Enable or disable channels in channel groups using the groups' tasks ENABLE and DISABLE. It needs to be defined which channels belong to which channel groups before these tasks are triggered.

Note: ENABLE tasks are prioritized over DISABLE tasks. When a channel belongs to two or more groups, for example group m and n, and the tasks CHG[m].EN and CHG[n].DIS occur simultaneously (m and n can be equal or different), the CHG[m].EN task on that channel is prioritized.

The DPPI configuration tasks (for example CHG[0].EN) can be triggered through DPPI like any other task, which means they can be linked to a DPPI channel through the subscribe registers.

In order to write to CHG[x], the corresponding CHG[x].EN and CHG[x].DIS subscribe registers must be disabled. Writes to CHG[x] are ignored if any of the two subscribe registers are enabled.

6.2.3 Connection examples

DPPI offers several connection options. Examples are given for how to create one-to-one and many-to-many connections.

One-to-one connection

This example shows how to create a one-to-one connection between TIMER compare register and SAADC start task.

The channel configuration is set up first. TIMER0 will publish its COMPARE0 event on channel 0, and SAADC will subscribe its START task to events on the same channel. After that, the channel is enabled through the DPPIC.

```
NRF_TIMER0->PUBLISH_COMPARE0 = (DPPI_PUB_CHIDX_Ch0) |
                                (DPPI_PUB_EN_Msk);
NRF_SAADC->SUBSCRIBE_START    = (DPPI_SUB_CHIDX_Ch0) |
                                (DPPI_SUB_EN_Msk);

NRF_DPPIC->CHENSET = (DPPI_CHENSET_CH0_Set << DPPI_CHENSET_CH0_Pos);
```

Many-to-many connection

The example shows how to create a many-to-many connection, showcasing the DPPIC's channel group functionality.

A channel group that includes only channel 0 is set up first. Then the GPIOTE and TIMER0 configure their IN0 and COMPARE0 events respectively to be published on channel 0, while the SAADC configures its START task to subscribe to events on channel 0. Through DPPIC, the CHG0 DISABLE task is configured to subscribe to events on channel 0. After an event is received on channel 0 it will be disabled. Finally, channel 0 is enabled using the DPPIC task to enable a channel group.

```
NRF_DPPIC->CHG[0] = (DPPI_CHG_CH0_Included << PPI_CHG_CH0_Pos);

NRF_GPIOTE->PUBLISH_IN0      = (DPPI_PUB_CHIDX_Ch0) |
                                (DPPI_PUB_EN_Msk);
NRF_TIMER0->PUBLISH_COMPARE0 = (DPPI_PUB_CHIDX_Ch0) |
                                (DPPI_PUB_EN_Msk);
NRF_SAADC->SUBSCRIBE_START   = (DPPI_SUB_CHIDX_Ch0) |
                                (DPPI_SUB_EN_Msk);
NRF_DPPIC->SUBSCRIBE_CHG[0].DIS = (DPPI_SUB_CHIDX_Ch0) |
                                (DPPI_SUB_EN_Msk);

NRF_DPPIC->TASK_CHG[0].EN = 1;
```

6.2.4 Special considerations for a system implementing TrustZone for Cortex-M processors

DPPI is implemented with split security, meaning it handles both secure and non-secure accesses. In a system implementing the TrustZone for Cortex-M technology, DPPI channels can be defined as secure or non-secure using the SPU.

A peripheral configured as non-secure will only be able to subscribe to or publish on non-secure DPPI channels. A peripheral configured as secure will be able to access all DPPI channels. DPPI handles both secure and non-secure accesses, but behaves differently depending on the access type:

- A non-secure peripheral access can only configure and control the DPPI channels defined as non-secure in the SPU.DPPI.PERM[] register(s)

- A secure peripheral access can control all the DPPI channels, independently of the SPU.DPPI.PERM[] register(s)

A group of channels can be created, making it possible to simultaneously enable or disable all channels within the group. The security attribute of a group of channels (secure or non-secure) is defined as follows:

- If all channels (enabled or not) within a group are non-secure, then the group is considered non-secure
- If at least one of the channels (enabled or not) within the group is secure, then the group is considered secure

A non-secure access to a DPPI register, or a bit field, controlling a channel marked as secure in SPU.DPPI[].PERM register(s) will be ignored. Write accesses will have no effect, and read accesses will always return a zero value.

No exceptions are triggered when non-secure accesses target a register or a bit field controlling a secure channel. For example, if the bit i is set in the SPU.DPPI[0].PERM register (declaring DPPI channel i as secure), then:

- Non-secure write accesses to registers CHEN, CHENSET, and CHENCLR cannot write bit i of these registers
- Non-secure write accesses to TASK_CHG[j].EN and TASK_CHG[j].DIS registers are ignored if the channel group j contains at least one channel defined as secure (it can be the channel i itself or any channel declared as secure)
- Non-secure read accesses to registers CHEN, CHENSET, and CHENCLR always read 0 for the bit at position i

For the channel configuration registers (CHG[]), access from non-secure code is only possible if the included channels are all non-secure, whether the channels are enabled or not. If a CHG[g] register included one or more secure channel(s), then the group g is considered as secure, and only secure transfers can read to or write from CHG[g]. A non-secure write access is ignored, and a non-secure read access returns 0.

The DPPI can subscribe to secure and non-secure channels through the SUBSCRIBE_CHG[] registers, in order to trigger the task for enabling or disabling groups of channels. An event from a secure channel will be ignored if the group subscribing to this channel is non-secure. A secure group can subscribe to a non-secure channel or a secure channel.

6.2.5 Registers

Instances

Instance	Base address	TrustZone			Split access	Description
		Map	Att	DMA		
DPPIC : S	0x50017000	HF	NS	NA	Yes	DPPI configuration
DPPIC : NS	0x40017000					

Register overview

Register	Offset	TZ	Description
TASKS_CHG[n].EN	0x000		Enable channel group n
TASKS_CHG[n].DIS	0x004		Disable channel group n
SUBSCRIBE_CHG[n].EN	0x080		Subscribe configuration for task CHG[n].EN
SUBSCRIBE_CHG[n].DIS	0x084		Subscribe configuration for task CHG[n].DIS
CHEN	0x500		Channel enable register
CHENSET	0x504		Channel enable set register
CHENCLR	0x508		Channel enable clear register
CHG[n]	0x800		Channel group n

Note: Writes to this register are ignored if either SUBSCRIBE_CHG[n].EN or SUBSCRIBE_CHG[n].DIS is enabled

6.2.5.1 TASKS_CHG[n] (n=0..5)

Channel group tasks

6.2.5.1.1 TASKS_CHG[n].EN (n=0..5)

Address offset: 0x000 + (n × 0x8)

Enable channel group n

Bit number	31 30 29 28 27 26 25 24 23 22 21 20 19 18 17 16 15 14 13 12 11 10 9 8 7 6 5 4 3 2 1 0																														
ID	A																														
Reset 0x00000000	0 0																														
ID	R/W	Field	Value ID	Value	Description																										
A	W	EN			Enable channel group n																										
			Trigger	1	Trigger task																										

6.2.5.1.2 TASKS_CHG[n].DIS (n=0..5)

Address offset: 0x004 + (n × 0x8)

Disable channel group n

Bit number	31 30 29 28 27 26 25 24 23 22 21 20 19 18 17 16 15 14 13 12 11 10 9 8 7 6 5 4 3 2 1 0																														
ID	A																														
Reset 0x00000000	0 0																														
ID	R/W	Field	Value ID	Value	Description																										
A	W	DIS			Disable channel group n																										
			Trigger	1	Trigger task																										

6.2.5.2 SUBSCRIBE_CHG[n] (n=0..5)

Subscribe configuration for tasks

6.2.5.2.1 SUBSCRIBE_CHG[n].EN (n=0..5)

Address offset: 0x080 + (n × 0x8)

Subscribe configuration for task CHG[n].EN

Bit number	31	30	29	28	27	26	25	24	23	22	21	20	19	18	17	16	15	14	13	12	11	10	9	8	7	6	5	4	3	2	1	0
ID	B																A A A A A A A A															
Reset	0x00000000																															
Reset	0 0																															
ID	R/W	Field	Value ID	Value	Description																											
A	RW	CHIDX		[0..255]	DPPI channel that task CHG[n].EN will subscribe to																											
B	RW	EN	Disabled	0	Disable subscription																											
			Enabled	1	Enable subscription																											

6.2.5.2.2 SUBSCRIBE_CHG[n].DIS (n=0..5)

Address offset: 0x084 + (n × 0x8)

Subscribe configuration for task **CHG[n].DIS**

Bit number	31	30	29	28	27	26	25	24	23	22	21	20	19	18	17	16	15	14	13	12	11	10	9	8	7	6	5	4	3	2	1	0
ID	B																A A A A A A A A															
Reset	0x00000000																															
Reset	0 0																															
ID	R/W	Field	Value ID	Value	Description																											
A	RW	CHIDX		[0..255]	DPPI channel that task CHG[n].DIS will subscribe to																											
B	RW	EN	Disabled	0	Disable subscription																											
			Enabled	1	Enable subscription																											

6.2.5.3 CHEN

Address offset: 0x500

Channel enable register

Bit number	31	30	29	28	27	26	25	24	23	22	21	20	19	18	17	16	15	14	13	12	11	10	9	8	7	6	5	4	3	2	1	0
ID																	P O N M L K J I H G F E D C B A															
Reset	0x00000000																															
Reset	0 0																															
ID	R/W	Field	Value ID	Value	Description																											
A-P	RW	CH[i] (i=0..15)			Enable or disable channel i																											
			Disabled	0	Disable channel																											
			Enabled	1	Enable channel																											

6.2.5.4 CHENSET

Address offset: 0x504

Channel enable set register

Note: Read: Reads value of CHi field in CHEN register

Bit number	31 30 29 28 27 26 25 24 23 22 21 20 19 18 17 16 15 14 13 12 11 10 9 8 7 6 5 4 3 2 1 0																																											
ID																													P	O	N	M	L	K	J	I	H	G	F	E	D	C	B	A
Reset 0x00000000	0 0																																											
ID	R/W	Field	Value ID	Value	Description																																							
A-P	RW	CH[i] (i=0..15)			Channel i enable set register. Writing 0 has no effect.																																							
		W1S																																										
			Disabled	0	Read: Channel disabled																																							
			Enabled	1	Read: Channel enabled																																							
			Set	1	Write: Enable channel																																							

6.2.5.5 CHENCLR

Address offset: 0x508

Channel enable clear register

Note: Read: Reads value of CHi field in CHEN register

Bit number	31 30 29 28 27 26 25 24 23 22 21 20 19 18 17 16 15 14 13 12 11 10 9 8 7 6 5 4 3 2 1 0																																											
ID																													P	O	N	M	L	K	J	I	H	G	F	E	D	C	B	A
Reset 0x00000000	0 0																																											
ID	R/W	Field	Value ID	Value	Description																																							
A-P	RW	CH[i] (i=0..15)			Channel i enable clear register. Writing 0 has no effect.																																							
		W1C																																										
			Disabled	0	Read: Channel disabled																																							
			Enabled	1	Read: Channel enabled																																							
			Clear	1	Write: Disable channel																																							

6.2.5.6 CHG[n] (n=0..5)

Address offset: 0x800 + (n × 0x4)

Channel group n

Note: Writes to this register are ignored if either SUBSCRIBE_CHG[n].EN or SUBSCRIBE_CHG[n].DIS is enabled

Bit number	31 30 29 28 27 26 25 24 23 22 21 20 19 18 17 16 15 14 13 12 11 10 9 8 7 6 5 4 3 2 1 0																																											
ID																													P	O	N	M	L	K	J	I	H	G	F	E	D	C	B	A
Reset 0x00000000	0 0																																											
ID	R/W	Field	Value ID	Value	Description																																							
A-P	RW	CH[i] (i=0..15)			Include or exclude channel i																																							
			Excluded	0	Exclude																																							
			Included	1	Include																																							

6.3 EGU — Event generator unit

Event generator unit (EGU) provides support for interlayer signaling. This means providing support for atomic triggering of both CPU execution and hardware tasks, from both firmware (by CPU) and hardware (by PPI). This feature can, for instance, be used for triggering CPU execution at a lower priority execution from a higher priority execution, or to handle a peripheral's interrupt service routine (ISR) execution at a lower priority for some of its events. However, triggering any priority from any priority is possible.

Listed here are the main EGU features:

- Software-enabled interrupt triggering
- Separate interrupt vectors for every EGU instance
- Up to 16 separate event flags per interrupt for multiplexing

Each instance of EGU implements a set of tasks which can individually be triggered to generate the corresponding event, for example, the corresponding event for TASKS_TRIGGER[n] is EVENTS_TRIGGERED[n]. See [Instances](#) on page 162 for a list of EGU instances.

6.3.1 Registers

Instances

Instance	Base address	TrustZone			Split access	Description
		Map	Att	DMA		
EGU0 : S	0x5001B000	US	NS	NA	No	Event generator unit 0
EGU0 : NS	0x4001B000					
EGU1 : S	0x5001C000	US	NS	NA	No	Event generator unit 1
EGU1 : NS	0x4001C000					
EGU2 : S	0x5001D000	US	NS	NA	No	Event generator unit 2
EGU2 : NS	0x4001D000					
EGU3 : S	0x5001E000	US	NS	NA	No	Event generator unit 3
EGU3 : NS	0x4001E000					
EGU4 : S	0x5001F000	US	NS	NA	No	Event generator unit 4
EGU4 : NS	0x4001F000					
EGU5 : S	0x50020000	US	NS	NA	No	Event generator unit 5
EGU5 : NS	0x40020000					

Register overview

Register	Offset	TZ	Description
TASKS_TRIGGER[n]	0x000		Trigger n for triggering the corresponding TRIGGERED[n] event
SUBSCRIBE_TRIGGER[n]	0x080		Subscribe configuration for task TRIGGER[n]
EVENTS_TRIGGERED[n]	0x100		Event number n generated by triggering the corresponding TRIGGER[n] task
PUBLISH_TRIGGERED[n]	0x180		Publish configuration for event TRIGGERED[n]
INTEN	0x300		Enable or disable interrupt
INTENSET	0x304		Enable interrupt
INTENCLR	0x308		Disable interrupt

6.3.1.1 TASKS_TRIGGER[n] (n=0..15)

Address offset: $0x000 + (n \times 0x4)$

Trigger n for triggering the corresponding TRIGGERED[n] event

Bit number	31 30 29 28 27 26 25 24 23 22 21 20 19 18 17 16 15 14 13 12 11 10 9 8 7 6 5 4 3 2 1 0																														
ID	A																														
Reset 0x00000000	0 0																														
ID	R/W	Field	Value ID	Value	Description																										
A	W	TASKS_TRIGGER	Trigger	1	Trigger n for triggering the corresponding TRIGGERED[n] event Trigger task																										

6.3.1.2 SUBSCRIBE_TRIGGER[n] (n=0..15)

Address offset: 0x080 + (n × 0x4)

Subscribe configuration for task TRIGGER[n]

Bit number	31 30 29 28 27 26 25 24 23 22 21 20 19 18 17 16 15 14 13 12 11 10 9 8 7 6 5 4 3 2 1 0																														
ID	B															A A A A A A A A															
Reset 0x00000000	0 0																														
ID	R/W	Field	Value ID	Value	Description																										
A	RW	CHIDX		[0..255]	DPPI channel that task TRIGGER[n] will subscribe to																										
B	RW	EN	Disabled	0	Disable subscription																										
			Enabled	1	Enable subscription																										

6.3.1.3 EVENTS_TRIGGERED[n] (n=0..15)

Address offset: 0x100 + (n × 0x4)

Event number n generated by triggering the corresponding TRIGGER[n] task

Bit number	31 30 29 28 27 26 25 24 23 22 21 20 19 18 17 16 15 14 13 12 11 10 9 8 7 6 5 4 3 2 1 0																														
ID																															A
Reset 0x00000000	0 0																														
ID	R/W	Field	Value ID	Value	Description																										
A	RW	EVENTS_TRIGGERED	NotGenerated	0	Event number n generated by triggering the corresponding TRIGGER[n] task																										
			Generated	1	Event not generated																										
					Event generated																										

6.3.1.4 PUBLISH_TRIGGERED[n] (n=0..15)

Address offset: 0x180 + (n × 0x4)

Publish configuration for event TRIGGERED[n]

Bit number	31 30 29 28 27 26 25 24 23 22 21 20 19 18 17 16 15 14 13 12 11 10 9 8 7 6 5 4 3 2 1 0																														
ID	B															A A A A A A A A															
Reset 0x00000000	0 0																														
ID	R/W	Field	Value ID	Value	Description																										
A	RW	CHIDX		[0..255]	DPPI channel that event TRIGGERED[n] will publish to																										
B	RW	EN	Disabled	0	Disable publishing																										
			Enabled	1	Enable publishing																										

6.3.1.5 INTEN

Address offset: 0x300

Enable or disable interrupt

Bit number	31	30	29	28	27	26	25	24	23	22	21	20	19	18	17	16	15	14	13	12	11	10	9	8	7	6	5	4	3	2	1	0
ID																	P	O	N	M	L	K	J	I	H	G	F	E	D	C	B	A
Reset 0x00000000	0 0																															
ID	R/W	Field	Value ID	Value	Description																											
A-P	RW	TRIGGERED[i] (i=0..15)			Enable or disable interrupt for event TRIGGERED[i]																											
			Disabled	0	Disable																											
			Enabled	1	Enable																											

6.3.1.6 INTENSET

Address offset: 0x304

Enable interrupt

Bit number	31	30	29	28	27	26	25	24	23	22	21	20	19	18	17	16	15	14	13	12	11	10	9	8	7	6	5	4	3	2	1	0
ID																	P	O	N	M	L	K	J	I	H	G	F	E	D	C	B	A
Reset 0x00000000	0 0																															
ID	R/W	Field	Value ID	Value	Description																											
A-P	RW	TRIGGERED[i] (i=0..15)			Write '1' to enable interrupt for event TRIGGERED[i]																											
			Set	1	Enable																											
			Disabled	0	Read: Disabled																											
			Enabled	1	Read: Enabled																											

6.3.1.7 INTENCLR

Address offset: 0x308

Disable interrupt

Bit number	31	30	29	28	27	26	25	24	23	22	21	20	19	18	17	16	15	14	13	12	11	10	9	8	7	6	5	4	3	2	1	0
ID																	P	O	N	M	L	K	J	I	H	G	F	E	D	C	B	A
Reset 0x00000000	0 0																															
ID	R/W	Field	Value ID	Value	Description																											
A-P	RW	TRIGGERED[i] (i=0..15)			Write '1' to disable interrupt for event TRIGGERED[i]																											
			Clear	1	Disable																											
			Disabled	0	Read: Disabled																											
			Enabled	1	Read: Enabled																											

6.3.2 Electrical specification

6.3.2.1 EGU Electrical Specification

Symbol	Description	Min.	Typ.	Max.	Units
$t_{EGU,EVT}$	Latency between setting an EGU event flag and the system setting an interrupt		1		cycles

6.4 GPIO — General purpose input/output

The general purpose input/output pins (GPIOs) are grouped as one or more ports with each port having up to 32 GPIOs.

The number of ports and GPIOs per port may vary with product variant and package. Refer to [Registers](#) on page 169 and [Pin assignments](#) on page 511 for more information about the number of GPIOs that are supported.

GPIO has the following user-configurable features:

- Up to 32 GPIO pins per GPIO port
- Configurable output drive strength
- Internal pull-up and pull-down resistors
- Wake-up from high or low level triggers on all pins
- Trigger interrupt on state changes on any pin
- All pins can be used by the PPI task/event system
- One or more GPIO outputs can be controlled through PPI and GPIOTE channels
- All pins can be individually mapped to interface blocks for layout flexibility
- GPIO state changes captured on SENSE signal can be stored by LATCH register
- Support for secure and non-secure attributes for pins in conjunction with the system protection unit (SPU — [System protection unit](#) on page 324)

[GPIO port and the GPIO pin details](#) on page 165 illustrates the GPIO port containing 32 individual pins, where `PIN0` is illustrated in more detail as a reference. All signals on the left side in the illustration are used by other peripherals in the system and therefore not directly available to the CPU.

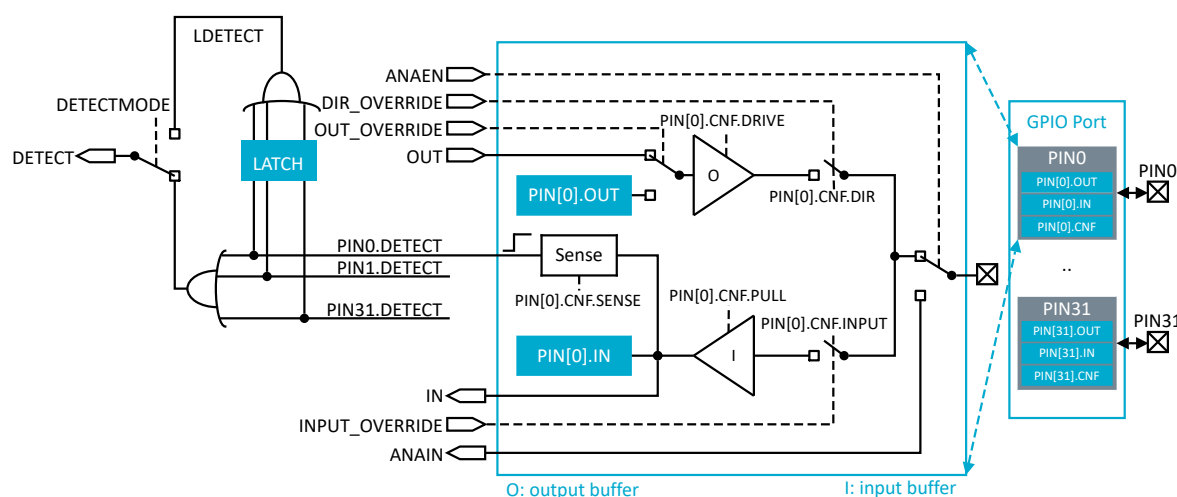

Figure 22: GPIO port and the GPIO pin details

6.4.1 Pin configuration

The GPIO port peripheral implements up to 32 pins, `PIN0` through `PIN31`. Each of these pins can be individually configured in the `PIN_CNF[n]` registers ($n=0..31$).

The following parameters can be configured through these registers:

- Direction
- Drive strength
- Enabling of pull-up and pull-down resistors
- Pin sensing
- Input buffer disconnect
- Analog input (for selected pins)

Note: All write-capable registers are retained registers, see [POWER — Power control](#) on page 69 for more information.

The input buffer of a GPIO pin can be disconnected from the pin to enable power savings when the pin is not used as an input, see [GPIO port and the GPIO pin details](#) on page 165. Inputs must be connected to get a valid input value in the `IN` register, and for the sense mechanism to get access to the pin.

Other peripherals in the system can connect to GPIO pins and override their output value and configuration, or read their analog or digital input value. See [GPIO port and the GPIO pin details](#) on page 165.

Selected pins also support analog input signals, see `ANAIN` in [GPIO port and the GPIO pin details](#) on page 165. The assignment of the analog pins can be found in [Pin assignments](#) on page 511.

The following delays should be taken into considerations:

- There is a delay of 2 CPU clock cycles from the GPIO pad to the `IN` register.
- The GPIO pad must be low (or high depending on the `SENSE` polarity) for 3 CPU clock cycles after `DETECT` has gone high to generate a new `DETECT` signal.

Note: When a pin is configured as digital input, care has been taken to minimize increased current consumption when the input voltage is between V_{IL} and V_{IH} . However, it is a good practice to ensure that the external circuitry does not drive that pin to levels between V_{IL} and V_{IH} for a long period of time.

6.4.2 Pin sense mechanism

Pins sensitivity can be individually configured, through the `SENSE` field in the `PIN_CNF[n]` register, to detect either a high level or a low level on their input.

When the correct level is detected on any such configured pin, the sense mechanism will set the `DETECT` signal high. Each pin has a separate `DETECT` signal. Default behavior, defined by the `DETECTMODE` register, is that the `DETECT` signals from all pins in the GPIO port are combined into one common `DETECT` signal that is routed throughout the system, which then can be utilized by other peripherals. This mechanism is functional in both System ON and System OFF modes.

`DETECTMODE` and `DETECTMODE_SEC` are provided to handle secure and non-secure pins.

`DETECTMODE_SEC` register is available to control the behavior associated to pin marked as secure, while the `DETECTMODE` register is restricted to pin marked as non-secure. Please refer to [GPIO security](#) on page 167 for more details.

Make sure that a pin is in a level that cannot trigger the sense mechanism before enabling it. The `DETECT` signal will go high immediately if the `SENSE` condition configured in the `PIN_CNF` registers is met when the sense mechanism is enabled. This will trigger a `PORT` event if the `DETECT` signal was low before enabling the sense mechanism.

The `DETECT` signal is also used by power and clock management system to exit from System OFF mode, and by `GPIO` to generate the `PORT` event. In addition `GPIO_SEC` is used for `PORT` event related to secure pins). See [POWER — Power control](#) on page 69 and [GPIO — GPIO tasks and events](#) on page 174 for more information about how the `DETECT` signal is used.

When a pin's `PINx.DETECT` signal goes high, a flag will be set in the `LATCH` register. For example, when the `PIN0.DETECT` signal goes high, bit 0 in the `LATCH` register will be set to '1'. If the CPU performs a clear operation on a bit in the `LATCH` register when the associated `PINx.DETECT` signal is high, the bit in the `LATCH` register will not be cleared. The `LATCH` register will only be cleared if the CPU explicitly clears it by writing a '1' to the bit that shall be cleared, i.e. the `LATCH` register will not be affected by a `PINx.DETECT` signal being set low.

The `LDETECT` signal will be set high when one or more bits in the `LATCH` register are '1'. The `LDETECT` signal will be set low when all bits in the `LATCH` register are successfully cleared to '0'.

If one or more bits in the **LATCH** register are '1' after the CPU has performed a clear operation on the **LATCH** registers, a rising edge will be generated on the LDETECT signal. This is illustrated in **DETECT signal behavior** on page 167.

Note: The CPU can read the **LATCH** register at any time to check if a SENSE condition has been met on one or more of the GPIO pins, even if that condition is no longer met at the time the CPU queries the **LATCH** register. This mechanism will work even if the LDETECT signal is not used as the DETECT signal.

The LDETECT signal is by default not connected to the GPIO port's DETECT signal, but via the DETECTMODE register it is possible to change from default behavior to DETECT signal being derived directly from the LDETECT signal instead. See **GPIO port and the GPIO pin details** on page 165. **DETECT signal behavior** on page 167 illustrates the DETECT signal behavior for these two alternatives.

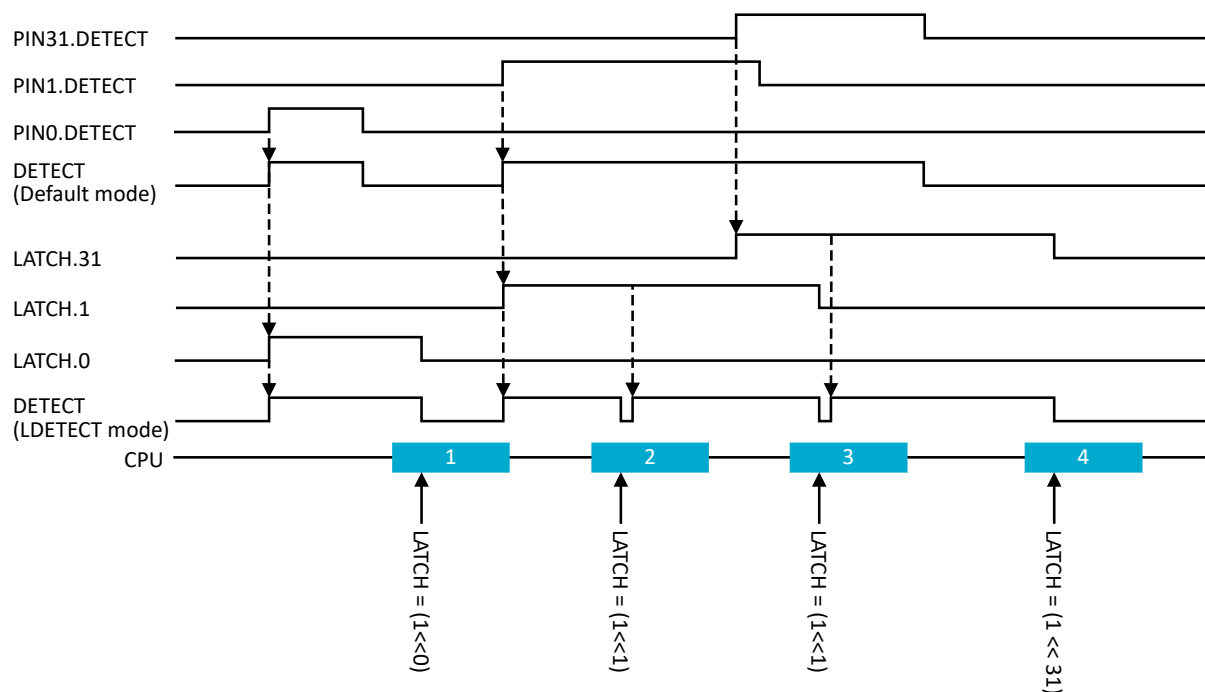

Figure 23: DETECT signal behavior

6.4.3 GPIO security

The general purpose input/output (GPIO) peripheral is implemented as a *split-security* peripheral. If marked as non-secure, it can be accessed by both secure and non-secure accesses but will behave differently depending on the access type.

A non-secure peripheral access will only be able to configure and control pins defined as non-secure in the system protection unit (SPU) GPIOPORT.PERM[] register(s).

A non-secure access to a register or a bitfield controlling a pin marked as secure in GPIO.PERM[] register(s) will be ignored. Write access will have no effect and read access will return a zero value.

No exception is triggered when a non-secure access targets a register or bitfield controlling a secure pin. For example, if the bit *i* is set in the SPU.GPIO.PERM[0] register (declaring Pin P0.*i* as secure), then

- non-secure write accesses to OUT, OUTSET, OUTCLR, DIR, DIRSET, DIRCLR and LATCH registers will not be able to write to bit *i* of those registers
- non-secure write accesses to registers PIN[*i*].OUT and PIN_CNF[*i*] will be ignored

- non-secure read accesses to registers OUT, OUTSET, OUTCLR, IN, DIR, DIRSET, DIRCLR and LATCH will always read a '0' for the bit at position i
- non-secure read accesses to registers PIN[i].OUT, PIN[i].OUT and PIN_CNF[i] will always return 0

The GPIO.DETECTMODE and GPIO.DETECTMODE_SEC registers are handled differently than the other registers mentioned before. When accessed by a secure access, the DETECTMODE_SEC register control the source for the DETECT_SEC signal for the pins marked as secure. When accessed by a non-secure access, the DETECTMODE_SEC is read as zero and write accesses are ignored. The GPIO.DETECTMODE register controls the source for the DETECT_NSEC signal for the pins defined as non-secure.

The DETECT_NSEC signal is routed to the GPIOTE peripheral, allowing generation of events and interrupts from pins marked as non-secure. The DETECT_SEC signal is routed to the GPIOTESEC peripheral, allowing generation of events and interrupts from pins marked as secure. [Principle of direct pin access](#) on page 168 illustrates how the DETECT_NSEC and DETECT_SEC signals are generated from the GPIO PIN[i].DETECT signals.

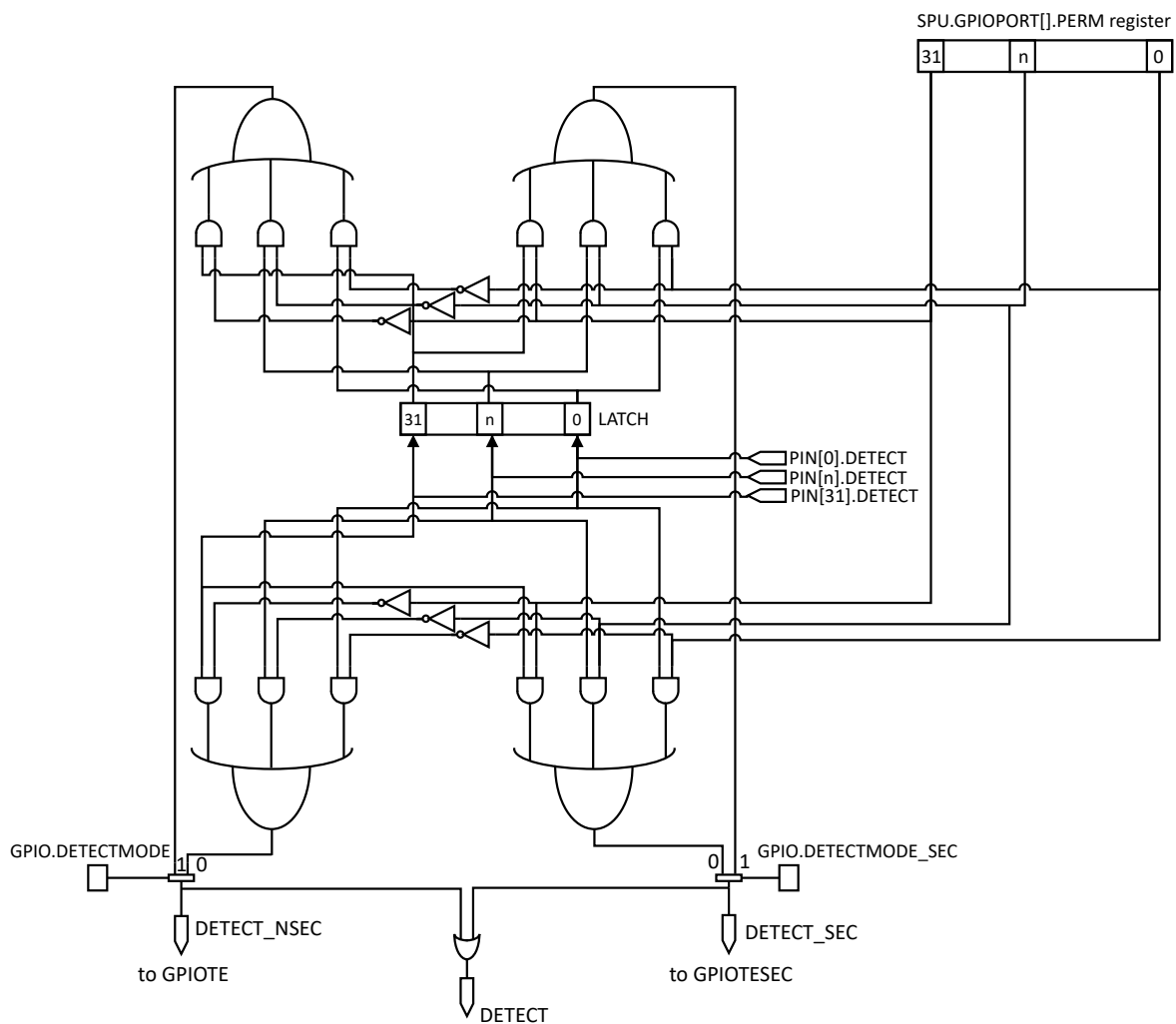

Figure 24: Principle of direct pin access

6.4.4 Registers

Instances

Instance	Base address	TrustZone			Split access	Description
		Map	Att	DMA		
P0 : S	0x50842500	HF	NS	NA	Yes	General purpose input and output
P0 : NS	0x40842500					

Register overview

Register	Offset	TZ	Description
OUT	0x004		Write GPIO port This register is retained.
OUTSET	0x008		Set individual bits in GPIO port
OUTCLR	0x00C		Clear individual bits in GPIO port
IN	0x010		Read GPIO port
DIR	0x014		Direction of GPIO pins This register is retained.
DIRSET	0x018		DIR set register
DIRCLR	0x01C		DIR clear register
LATCH	0x020		Latch register indicating what GPIO pins that have met the criteria set in the PIN_CNF[n].SENSE registers This register is retained.
DETECTMODE	0x024		Select between default DETECT signal behavior and LDETECT mode (For non-secure pin only) This register is retained.
DETECTMODE_SEC	0x028		Select between default DETECT signal behavior and LDETECT mode (For secure pin only) This register is retained.
PIN_CNF[n]	0x200		Configuration of GPIO pins This register is retained.

6.4.4.1 OUT (Retained)

Address offset: 0x004

Write GPIO port

This register is retained.

Bit number																															
ID	f e d c b a z Y X W V U T S R Q P O N M L K J I H G F E D C B A																														
Reset	0 0																														
ID	R/W	Field	Value ID	Value	Description																										
A-f	RW	PIN[i] (i=0..31)			Pin i																										
			Low	0	Pin driver is low																										
			High	1	Pin driver is high																										

6.4.4.2 OUTSET

Address offset: 0x008

Set individual bits in GPIO port

Read: reads value of OUT register.

Bit number	31	30	29	28	27	26	25	24	23	22	21	20	19	18	17	16	15	14	13	12	11	10	9	8	7	6	5	4	3	2	1	0
ID	f	e	d	c	b	a	Z	Y	X	W	V	U	T	S	R	Q	P	O	N	M	L	K	J	I	H	G	F	E	D	C	B	A
Reset 0x00000000	0	0	0	0	0	0	0	0	0	0	0	0	0	0	0	0	0	0	0	0	0	0	0	0	0	0	0	0	0	0	0	0
ID	R/W	Field	Value ID	Value	Description																											
A-f	RW	PIN[i] (i=0..31)			Pin i																											
		W1S																														
			Low	0	Read: pin driver is low																											
			High	1	Read: pin driver is high																											
			Set	1	Write: writing a '1' sets the pin high; writing a '0' has no effect																											

6.4.4.3 OUTCLR

Address offset: 0x00C

Clear individual bits in GPIO port

Read: reads value of OUT register.

Bit number	31	30	29	28	27	26	25	24	23	22	21	20	19	18	17	16	15	14	13	12	11	10	9	8	7	6	5	4	3	2	1	0
ID	f	e	d	c	b	a	Z	Y	X	W	V	U	T	S	R	Q	P	O	N	M	L	K	J	I	H	G	F	E	D	C	B	A
Reset 0x00000000	0	0	0	0	0	0	0	0	0	0	0	0	0	0	0	0	0	0	0	0	0	0	0	0	0	0	0	0	0	0	0	0
ID	R/W	Field	Value ID	Value	Description																											
A-f	RW	PIN[i] (i=0..31)			Pin i																											
		W1C																														
			Low	0	Read: pin driver is low																											
			High	1	Read: pin driver is high																											
			Clear	1	Write: writing a '1' sets the pin low; writing a '0' has no effect																											

6.4.4.4 IN

Address offset: 0x010

Read GPIO port

Bit number	31	30	29	28	27	26	25	24	23	22	21	20	19	18	17	16	15	14	13	12	11	10	9	8	7	6	5	4	3	2	1	0
ID	f	e	d	c	b	a	Z	Y	X	W	V	U	T	S	R	Q	P	O	N	M	L	K	J	I	H	G	F	E	D	C	B	A
Reset 0x00000000	0	0	0	0	0	0	0	0	0	0	0	0	0	0	0	0	0	0	0	0	0	0	0	0	0	0	0	0	0	0	0	0
ID	R/W	Field	Value ID	Value	Description																											
A-f	R	PIN[i] (i=0..31)			Pin i																											
			Low	0	Pin input is low																											
			High	1	Pin input is high																											

6.4.4.5 DIR (Retained)

Address offset: 0x014

Direction of GPIO pins

This register is retained.

Bit number	31	30	29	28	27	26	25	24	23	22	21	20	19	18	17	16	15	14	13	12	11	10	9	8	7	6	5	4	3	2	1	0
ID	f	e	d	c	b	a	Z	Y	X	W	V	U	T	S	R	Q	P	O	N	M	L	K	J	I	H	G	F	E	D	C	B	A
Reset 0x00000000	0	0	0	0	0	0	0	0	0	0	0	0	0	0	0	0	0	0	0	0	0	0	0	0	0	0	0	0	0	0	0	0
ID	R/W	Field	Value ID	Value	Description																											
A-f	RW	PIN[i] (i=0..31)			Pin i																											
			Input	0	Pin set as input																											
			Output	1	Pin set as output																											

6.4.4.6 DIRSET

Address offset: 0x018

DIR set register

Read: reads value of DIR register.

Bit number	31	30	29	28	27	26	25	24	23	22	21	20	19	18	17	16	15	14	13	12	11	10	9	8	7	6	5	4	3	2	1	0
ID	f	e	d	c	b	a	Z	Y	X	W	V	U	T	S	R	Q	P	O	N	M	L	K	J	I	H	G	F	E	D	C	B	A
Reset 0x00000000	0	0	0	0	0	0	0	0	0	0	0	0	0	0	0	0	0	0	0	0	0	0	0	0	0	0	0	0	0	0	0	0
ID	R/W	Field	Value ID	Value	Description																											
A-f	RW	PIN[i] (i=0..31)			Set as output pin i																											
		W1S																														
			Input	0	Read: pin set as input																											
			Output	1	Read: pin set as output																											
			Set	1	Write: writing a '1' sets pin to output; writing a '0' has no effect																											

6.4.4.7 DIRCLR

Address offset: 0x01C

DIR clear register

Read: reads value of DIR register.

Bit number	31	30	29	28	27	26	25	24	23	22	21	20	19	18	17	16	15	14	13	12	11	10	9	8	7	6	5	4	3	2	1	0
ID	f	e	d	c	b	a	Z	Y	X	W	V	U	T	S	R	Q	P	O	N	M	L	K	J	I	H	G	F	E	D	C	B	A
Reset 0x00000000	0	0	0	0	0	0	0	0	0	0	0	0	0	0	0	0	0	0	0	0	0	0	0	0	0	0	0	0	0	0	0	0
ID	R/W	Field	Value ID	Value	Description																											
A-f	RW	PIN[i] (i=0..31)			Set as input pin i																											
		W1C																														
			Input	0	Read: pin set as input																											
			Output	1	Read: pin set as output																											
			Clear	1	Write: writing a '1' sets pin to input; writing a '0' has no effect																											

6.4.4.8 LATCH (Retained)

Address offset: 0x020

Latch register indicating what GPIO pins that have met the criteria set in the PIN_CNF[n].SENSE registers

This register is retained.

Bit number	31	30	29	28	27	26	25	24	23	22	21	20	19	18	17	16	15	14	13	12	11	10	9	8	7	6	5	4	3	2	1	0
ID	f e d c b a Z Y X W V U T S R Q P O N M L K J I H G F E D C B A																															
Reset 0x00000000	0 0																															
ID	R/W	Field	Value ID	Value	Description																											
A-f	RW	PIN[i] (i=0..31)			Status on whether PIN[i] has met criteria set in PIN_CNF[i].SENSE register. Write '1' to clear.																											
			NotLatched	0	Criteria has not been met																											
			Latched	1	Criteria has been met																											

6.4.4.9 DETECTMODE (Retained)

Address offset: 0x024

Select between default DETECT signal behavior and LDETECT mode (For non-secure pin only)

This register is retained.

Bit number	31	30	29	28	27	26	25	24	23	22	21	20	19	18	17	16	15	14	13	12	11	10	9	8	7	6	5	4	3	2	1	0
ID																																A
Reset 0x00000000	0 0																															
ID	R/W	Field	Value ID	Value	Description																											
A	RW	DETECTMODE			Select between default DETECT signal behavior and LDETECT mode																											
			Default	0	DETECT directly connected to PIN DETECT signals																											
			LDETECT	1	Use the latched LDETECT behavior																											

6.4.4.10 DETECTMODE_SEC (Retained)

Address offset: 0x028

Select between default DETECT signal behavior and LDETECT mode (For secure pin only)

This register is retained.

Bit number	31	30	29	28	27	26	25	24	23	22	21	20	19	18	17	16	15	14	13	12	11	10	9	8	7	6	5	4	3	2	1	0
ID																																A
Reset 0x00000000	0 0																															
ID	R/W	Field	Value ID	Value	Description																											
A	RW	DETECTMODE			Select between default DETECT signal behavior and LDETECT mode																											
			Default	0	DETECT directly connected to PIN DETECT signals																											
			LDETECT	1	Use the latched LDETECT behavior																											

6.4.4.11 PIN_CNF[n] (n=0..31) (Retained)

Address offset: 0x200 + (n × 0x4)

Configuration of GPIO pins

This register is retained.

Bit number	31	30	29	28	27	26	25	24	23	22	21	20	19	18	17	16	15	14	13	12	11	10	9	8	7	6	5	4	3	2	1	0			
ID																E	E							D	D	D							C	C	B
Reset 0x00000002	0 1 0																																		
ID	R/W	Field	Value ID	Value	Description																														
	RW	DIR			Pin direction. Same physical register as DIR register																														
			Input	0	Configure pin as an input pin																														
			Output	1	Configure pin as an output pin																														

Bit number	31 30 29 28 27 26 25 24 23 22 21 20 19 18 17 16 15 14 13 12 11 10 9 8 7 6 5 4 3 2 1 0																														
ID	E E															D D D						C C B									
Reset 0x00000002																															
0 0																															
ID	R/W	Field	Value ID	Value	Description																										
B	RW	INPUT			Connect or disconnect input buffer																										
			Connect	0	Connect input buffer																										
			Disconnect	1	Disconnect input buffer																										
C	RW	PULL			Pull configuration																										
			Disabled	0	No pull																										
			Pulldown	1	Pull down on pin																										
			Pullup	3	Pull up on pin																										
D-	RW	DRIVE			Drive configuration																										
			S0S1	0	Standard '0', standard '1'																										
			H0S1	1	High drive '0', standard '1'																										
			S0H1	2	Standard '0', high drive '1'																										
			H0H1	3	High drive '0', high 'drive '1''																										
			D0S1	4	Disconnect '0', standard '1' (normally used for wired-or connections)																										
			D0H1	5	Disconnect '0', high drive '1' (normally used for wired-or connections)																										
			S0D1	6	Standard '0', disconnect '1' (normally used for wired-and connections)																										
H0D1	7	High drive '0', disconnect '1' (normally used for wired-and connections)																													
E	RW	SENSE			Pin sensing mechanism																										
			Disabled	0	Disabled																										
			High	2	Sense for high level																										
			Low	3	Sense for low level																										

6.4.5 Electrical specification

6.4.5.1 GPIO Electrical Specification

Note: VDD in the following table refers to VDD_GPIO.

Symbol	Description	Min.	Typ.	Max.	Units
V _{IH}	Input high voltage	0.7 x VDD		VDD	V
V _{IL}	Input low voltage	VSS		0.3 x VDD	V
V _{OH,SD}	Output high voltage, standard drive, 0.5 mA, VDD ≥ 1.7 V	VDD-0.4		VDD	V
V _{OH,HDH}	Output high voltage, high drive, 5 mA, VDD ≥ 2.7 V	VDD-0.4		VDD	V
V _{OH,HDL}	Output high voltage, high drive, 3 mA, VDD ≥ 1.7 V	VDD-0.4		VDD	V
V _{OL,SD}	Output low voltage, standard drive, 0.5 mA, VDD ≥ 1.7 V	VSS		VSS+0.4	V
V _{OL,HDH}	Output low voltage, high drive, 5 mA, VDD ≥ 2.7 V	VSS		VSS+0.4	V
V _{OL,HDL}	Output low voltage, high drive, 3 mA, VDD ≥ 1.7 V	VSS		VSS+0.4	V
I _{OL,SD}	Current at VSS + 0.4 V, output set low, standard drive, VDD ≥ 1.7 V	1	2	4	mA
I _{OL,HDH}	Current at VSS + 0.4 V, output set low, high drive, VDD ≥ 2.7 V	6	10	15	mA
I _{OL,HDL}	Current at VSS + 0.4 V, output set low, high drive, VDD ≥ 1.7 V	3			mA
I _{OH,SD}	Current at VDD - 0.4 V, output set high, standard drive, VDD ≥ 1.7	1	2	4	mA
I _{OH,HDH}	Current at VDD - 0.4 V, output set high, high drive, VDD ≥ 2.7 V	6	9	14	mA
I _{OH,HDL}	Current at VDD - 0.4 V, output set high, high drive, VDD ≥ 1.7 V	3			mA
t _{RF,15pF}	Rise/fall time, standard drive mode, 10 to 90%, 15 pF load ¹	6	9	19	ns
t _{RF,25pF}	Rise/fall time, standard drive mode, 10 to 90%, 25 pF load ¹	10	13	30	ns
t _{RF,50pF}	Rise/fall time, standard drive mode, 10 to 90%, 50 pF load ¹	18	25	61	ns
t _{H,15pF}	Rise/Fall time, high drive mode, 10 to 90%, 15 pF load ¹	2	4	8	ns

¹ Rise and fall times based on simulations

Symbol	Description	Min.	Typ.	Max.	Units
$t_{HRF,25pF}$	Rise/Fall time, high drive mode, 10 to 90%, 25 pF load ¹	3	5	11	ns
$t_{HRF,50pF}$	Rise/Fall time, high drive mode, 10 to 90%, 50 pF load ¹	5	8	19	ns
R_{PU}	Pull-up resistance	11	13	16	k Ω
R_{PD}	Pull-down resistance	11	13	16	k Ω
C_{PAD}	Pad capacitance		3		pF

6.5 GPIOTE — GPIO tasks and events

The GPIOTE tasks and events (GPIOTE) module provides functionality for accessing GPIO pins using tasks and events. Each GPIOTE channel can be assigned to one pin.

A GPIOTE block enables GPIOs to generate events on pin state change which can be used to carry out tasks through the PPI system. A GPIO can also be driven to change state on system events using the PPI system. Tasks and events are briefly introduced in [Peripheral interface](#) on page 17, and GPIO is described in more detail in [GPIO — General purpose input/output](#) on page 164.

Low power detection of pin state changes is possible when in System ON or System OFF.

Instance	Number of GPIOTE channels
GPIOTE	8

Table 18: GPIOTE properties

Up to three tasks can be used in each GPIOTE channel for performing write operations to a pin. Two tasks are fixed (SET and CLR), and one (OUT) is configurable to perform following operations:

- Set
- Clear
- Toggle

An event can be generated in each GPIOTE channel from one of the following input conditions:

- Rising edge
- Falling edge
- Any change

6.5.1 Pin events and tasks

The GPIOTE module has a number of tasks and events that can be configured to operate on individual GPIO pins.

The tasks SET[n], CLR[n], and OUT[n] can write to individual pins, and events IN[n] can be generated from input changes of individual pins.

The SET task will set the pin selected in `GPIOTE.CONFIG[n].PSEL` to high. The CLR task will set the pin low.

The effect of the OUT task on the pin is configurable in `CONFIG[n].POLARITY`. It can set the pin high, set it low, or toggle it.

Tasks and events are configured using the CONFIG[n] registers. One CONFIG[n] register is associated with a set of SET[n], CLR[n], and OUT[n] tasks and IN[n] events.

As long as a SET[n], CLR[n], and OUT[n] task or an IN[n] event is configured to control pin n, the pin's output value will only be updated by the GPIOTE module. The pin's output value, as specified in the GPIO, will be ignored as long as the pin is controlled by GPIOTE. Attempting to write to the pin as a normal GPIO pin will have no effect. When the GPIOTE is disconnected from a pin, the associated pin gets the output and configuration values specified in the GPIO module, see MODE field in CONFIG[n] register.

When conflicting tasks are triggered simultaneously (i.e. during the same clock cycle) in one channel, the priority of the tasks is as described in the following table.

Priority	Task
1	OUT
2	CLR
3	SET

Table 19: Task priorities

When setting the CONFIG[n] registers, MODE=Disabled does not have the same effect as MODE=Task and POLARITY=None. In the latter case, a CLR or SET task occurring at the exact same time as OUT will end up with no change on the pin, based on the priorities described in the table above.

When a GPIOTE channel is configured to operate on a pin as a task, the initial value of that pin is configured in the OUTINIT field of CONFIG[n].

6.5.2 Port event

PORT is an event that can be generated from multiple input pins using the GPIO DETECT signal.

The event will be generated on the rising edge of the DETECT signal. See [GPIO — General purpose input/output](#) on page 164 for more information about the DETECT signal.

The GPIO DETECT signal will not wake the system up again if the system is put into System ON IDLE while the DETECT signal is high. Clear all DETECT sources before entering sleep. If the LATCH register is used as a source, a new rising edge will be generated on DETECT if any bit in LATCH is still high after clearing all or part of the register. This could occur if one of the PINx.DETECT signals is still high, for example. See [Pin sense mechanism](#) on page 166 for more information.

Setting the system to System OFF while DETECT is high will cause a wakeup from System OFF reset.

This feature can be used to wake up the CPU from a WFI or WFE type sleep in System ON when all peripherals and the CPU are idle, meaning the lowest power consumption in System ON mode.

To prevent spurious interrupts from the PORT event while configuring the sources, the following steps must be performed:

1. Disable interrupts on the PORT event (through INTENCLR.PORT).
2. Configure the sources (PIN_CNF[n].SENSE).
3. Clear any potential event that could have occurred during configuration (write 0 to EVENTS_PORT).
4. Enable interrupts (through INTENSET.PORT).

6.5.3 Tasks and events pin configuration

Each GPIOTE channel is associated with one physical GPIO pin through the CONFIG.PSEL field.

When Event mode is selected in CONFIG.MODE, the pin specified by CONFIG.PSEL will be configured as an input, overriding the DIR setting in GPIO. Similarly, when Task mode is selected in CONFIG.MODE, the pin specified by CONFIG.PSEL will be configured as an output overriding the DIR setting and OUT value in GPIO. When Disabled is selected in CONFIG.MODE, the pin specified by CONFIG.PSEL will use its configuration from the PIN[n].CNF registers in GPIO. CONFIG.MODE must be disabled in order to be able to change the value of the PSEL field.

Note: A pin can only be assigned to one GPIOTE channel at a time. Failing to do so may result in unpredictable behavior.

6.5.4 Registers

Instances

Instance	Base address	TrustZone			Split access	Description
		Map	Att	DMA		
GPIOTE0	0x5000D000	HF	S	NA	No	Secure GPIO tasks and events
GPIOTE1	0x40031000	HF	NS	NA	No	Non Secure GPIO tasks and events

Register overview

Register	Offset	TZ	Description
TASKS_OUT[n]	0x000		Task for writing to pin specified in CONFIG[n].PSEL. Action on pin is configured in CONFIG[n].POLARITY.
TASKS_SET[n]	0x030		Task for writing to pin specified in CONFIG[n].PSEL. Action on pin is to set it high.
TASKS_CLR[n]	0x060		Task for writing to pin specified in CONFIG[n].PSEL. Action on pin is to set it low.
SUBSCRIBE_OUT[n]	0x080		Subscribe configuration for task OUT[n]
SUBSCRIBE_SET[n]	0x0B0		Subscribe configuration for task SET[n]
SUBSCRIBE_CLR[n]	0x0E0		Subscribe configuration for task CLR[n]
EVENTS_IN[n]	0x100		Event generated from pin specified in CONFIG[n].PSEL
EVENTS_PORT	0x17C		Event generated from multiple input GPIO pins with SENSE mechanism enabled
PUBLISH_IN[n]	0x180		Publish configuration for event IN[n]
PUBLISH_PORT	0x1FC		Publish configuration for event PORT
INTENSET	0x304		Enable interrupt
INTENCLR	0x308		Disable interrupt
CONFIG[n]	0x510		Configuration for OUT[n], SET[n], and CLR[n] tasks and IN[n] event

6.5.4.1 TASKS_OUT[n] (n=0..7)

Address offset: $0x000 + (n \times 0x4)$

Task for writing to pin specified in CONFIG[n].PSEL. Action on pin is configured in CONFIG[n].POLARITY.

Bit number	31 30 29 28 27 26 25 24 23 22 21 20 19 18 17 16 15 14 13 12 11 10 9 8 7 6 5 4 3 2 1 0																															
ID																																A
Reset	0x00000000																															0
ID	R/W	Field	Value ID	Value	Description																											
A	W	TASKS_OUT			Task for writing to pin specified in CONFIG[n].PSEL. Action on pin is configured in CONFIG[n].POLARITY.																											
			Trigger	1	Trigger task																											

6.5.4.2 TASKS_SET[n] (n=0..7)

Address offset: $0x030 + (n \times 0x4)$

Task for writing to pin specified in CONFIG[n].PSEL. Action on pin is to set it high.

Bit number	31	30	29	28	27	26	25	24	23	22	21	20	19	18	17	16	15	14	13	12	11	10	9	8	7	6	5	4	3	2	1	0	
ID																																A	
Reset	0x00000000																																
0	0	0	0	0	0	0	0	0	0	0	0	0	0	0	0	0	0	0	0	0	0	0	0	0	0	0	0	0	0	0	0	0	0
ID	R/W	Field	Value ID	Value	Description																												
A	W	TASKS_SET			Task for writing to pin specified in CONFIG[n].PSEL. Action on pin is to set it high.																												
			Trigger	1	Trigger task																												

6.5.4.3 TASKS_CLR[n] (n=0..7)

Address offset: 0x060 + (n × 0x4)

Task for writing to pin specified in CONFIG[n].PSEL. Action on pin is to set it low.

Bit number	31	30	29	28	27	26	25	24	23	22	21	20	19	18	17	16	15	14	13	12	11	10	9	8	7	6	5	4	3	2	1	0
ID																																A
Reset	0x00000000																															
0	0	0	0	0	0	0	0	0	0	0	0	0	0	0	0	0	0	0	0	0	0	0	0	0	0	0	0	0	0	0	0	0
ID	R/W	Field	Value ID	Value	Description																											
A	W	TASKS_CLR			Task for writing to pin specified in CONFIG[n].PSEL. Action on pin is to set it low.																											
			Trigger	1	Trigger task																											

6.5.4.4 SUBSCRIBE_OUT[n] (n=0..7)

Address offset: 0x080 + (n × 0x4)

Subscribe configuration for task OUT[n]

Bit number	31	30	29	28	27	26	25	24	23	22	21	20	19	18	17	16	15	14	13	12	11	10	9	8	7	6	5	4	3	2	1	0																						
ID	B																								A			A	A	A	A	A	A	A	A	A	A	A	A	A	A	A	A	A	A	A	A	A	A	A	A	A	A	A
Reset	0x00000000																																																					
0	0	0	0	0	0	0	0	0	0	0	0	0	0	0	0	0	0	0	0	0	0	0	0	0	0	0	0	0	0	0	0	0	0																					
ID	R/W	Field	Value ID	Value	Description																																																	
A	RW	CHIDX		[0..255]	DPPI channel that task OUT[n] will subscribe to																																																	
B	RW	EN	Disabled	0	Disable subscription																																																	
			Enabled	1	Enable subscription																																																	

6.5.4.5 SUBSCRIBE_SET[n] (n=0..7)

Address offset: 0x0B0 + (n × 0x4)

Subscribe configuration for task SET[n]

Bit number	31	30	29	28	27	26	25	24	23	22	21	20	19	18	17	16	15	14	13	12	11	10	9	8	7	6	5	4	3	2	1	0																					
ID	B																								A			A	A	A	A	A	A	A	A	A	A	A	A	A	A	A	A	A	A	A	A	A	A	A	A	A	A
Reset	0x00000000																																																				
0	0	0	0	0	0	0	0	0	0	0	0	0	0	0	0	0	0	0	0	0	0	0	0	0	0	0	0	0	0	0	0	0	0																				
ID	R/W	Field	Value ID	Value	Description																																																
A	RW	CHIDX		[0..255]	DPPI channel that task SET[n] will subscribe to																																																
B	RW	EN	Disabled	0	Disable subscription																																																
			Enabled	1	Enable subscription																																																

6.5.4.6 SUBSCRIBE_CLR[n] (n=0..7)

Address offset: 0x0E0 + (n × 0x4)

Subscribe configuration for task CLR[n]

Bit number	31 30 29 28 27 26 25 24 23 22 21 20 19 18 17 16 15 14 13 12 11 10 9 8 7 6 5 4 3 2 1 0																														
ID	B															A A A A A A A A															
Reset 0x00000000	0 0																														
ID	R/W	Field	Value ID	Value	Description																										
A	RW	CHIDX		[0..255]	DPPI channel that task CLR[n] will subscribe to																										
B	RW	EN	Disabled	0	Disable subscription																										
			Enabled	1	Enable subscription																										

6.5.4.7 EVENTS_IN[n] (n=0..7)

Address offset: 0x100 + (n × 0x4)

Event generated from pin specified in CONFIG[n].PSEL

Bit number	31 30 29 28 27 26 25 24 23 22 21 20 19 18 17 16 15 14 13 12 11 10 9 8 7 6 5 4 3 2 1 0																														
ID																															A
Reset 0x00000000	0 0																														
ID	R/W	Field	Value ID	Value	Description																										
A	RW	EVENTS_IN	NotGenerated	0	Event not generated																										
			Generated	1	Event generated																										

6.5.4.8 EVENTS_PORT

Address offset: 0x17C

Event generated from multiple input GPIO pins with SENSE mechanism enabled

Bit number	31 30 29 28 27 26 25 24 23 22 21 20 19 18 17 16 15 14 13 12 11 10 9 8 7 6 5 4 3 2 1 0																														
ID																															A
Reset 0x00000000	0 0																														
ID	R/W	Field	Value ID	Value	Description																										
A	RW	EVENTS_PORT	NotGenerated	0	Event not generated																										
			Generated	1	Event generated																										

6.5.4.9 PUBLISH_IN[n] (n=0..7)

Address offset: 0x180 + (n × 0x4)

Publish configuration for event IN[n]

Bit number	31 30 29 28 27 26 25 24 23 22 21 20 19 18 17 16 15 14 13 12 11 10 9 8 7 6 5 4 3 2 1 0																														
ID	B															A A A A A A A A															
Reset 0x00000000	0 0																														
ID	R/W	Field	Value ID	Value	Description																										
A	RW	CHIDX		[0..255]	DPPI channel that event IN[n] will publish to																										
B	RW	EN	Disabled	0	Disable publishing																										
			Enabled	1	Enable publishing																										

6.5.4.10 PUBLISH_PORT

Address offset: 0x1FC

Publish configuration for event `PORT`

Bit number	31 30 29 28 27 26 25 24 23 22 21 20 19 18 17 16 15 14 13 12 11 10 9 8 7 6 5 4 3 2 1 0																														
ID	B															A A A A A A A A															
Reset 0x00000000	0 0																														
ID	R/W	Field	Value ID	Value	Description																										
A	RW	CHIDX		[0..255]	DPPI channel that event <code>PORT</code> will publish to																										
B	RW	EN	Disabled	0	Disable publishing																										
			Enabled	1	Enable publishing																										

6.5.4.11 INTENSET

Address offset: 0x304

Enable interrupt

Bit number	31 30 29 28 27 26 25 24 23 22 21 20 19 18 17 16 15 14 13 12 11 10 9 8 7 6 5 4 3 2 1 0																														
ID	I															H G F E D C B A															
Reset 0x00000000	0 0																														
ID	R/W	Field	Value ID	Value	Description																										
A-H	RW	IN[i] (i=0..7)	Set	1	Write '1' to enable interrupt for event IN[i] Enable																										
			Disabled	0	Read: Disabled																										
			Enabled	1	Read: Enabled																										
I	RW	PORT	Set	1	Write '1' to enable interrupt for event <code>PORT</code> Enable																										
			Disabled	0	Read: Disabled																										
			Enabled	1	Read: Enabled																										

6.5.4.12 INTENCLR

Address offset: 0x308

Disable interrupt

Bit number	31 30 29 28 27 26 25 24 23 22 21 20 19 18 17 16 15 14 13 12 11 10 9 8 7 6 5 4 3 2 1 0																														
ID	I															H G F E D C B A															
Reset 0x00000000	0 0																														
ID	R/W	Field	Value ID	Value	Description																										
A-H	RW	IN[i] (i=0..7)	Clear	1	Write '1' to disable interrupt for event IN[i] Disable																										
			Disabled	0	Read: Disabled																										
			Enabled	1	Read: Enabled																										
I	RW	PORT	Clear	1	Write '1' to disable interrupt for event <code>PORT</code> Disable																										
			Disabled	0	Read: Disabled																										
			Enabled	1	Read: Enabled																										

6.5.4.13 CONFIG[n] (n=0..7)

Address offset: 0x510 + (n × 0x4)

Configuration for OUT[n], SET[n], and CLR[n] tasks and IN[n] event

Bit number	31 30 29 28 27 26 25 24 23 22 21 20 19 18 17 16 15 14 13 12 11 10 9 8 7 6 5 4 3 2 1 0																																			
ID																					D	C	C	B				B	B	B	B	A				A
Reset 0x00000000	0 0																																			
ID	R/W	Field	Value ID	Value	Description																															
A	RW	MODE	Mode																																	
			Disabled	0	Disabled. Pin specified by PSEL will not be acquired by the GPIOTE module.																															
			Event	1	Event mode The pin specified by PSEL will be configured as an input and the IN[n] event will be generated if operation specified in POLARITY occurs on the pin.																															
			Task	3	Task mode The GPIO specified by PSEL will be configured as an output and triggering the SET[n], CLR[n] or OUT[n] task will perform the operation specified by POLARITY on the pin. When enabled as a task the GPIOTE module will acquire the pin and the pin can no longer be written as a regular output pin from the GPIO module.																															
B	RW	PSEL		[0..31]	GPIO number associated with SET[n], CLR[n], and OUT[n] tasks and IN[n] event																															
C	RW	POLARITY	When In task mode: Operation to be performed on output when OUT[n] task is triggered. When In event mode: Operation on input that shall trigger IN[n] event.																																	
			None	0	Task mode: No effect on pin from OUT[n] task. Event mode: no IN[n] event generated on pin activity.																															
			LoToHi	1	Task mode: Set pin from OUT[n] task. Event mode: Generate IN[n] event when rising edge on pin.																															
			HiToLo	2	Task mode: Clear pin from OUT[n] task. Event mode: Generate IN[n] event when falling edge on pin.																															
			Toggle	3	Task mode: Toggle pin from OUT[n]. Event mode: Generate IN[n] when any change on pin.																															
D	RW	OUTINIT	When in task mode: Initial value of the output when the GPIOTE channel is configured. When in event mode: No effect.																																	
			Low	0	Task mode: Initial value of pin before task triggering is low																															
			High	1	Task mode: Initial value of pin before task triggering is high																															

6.6 IPC — Interprocessor communication

The interprocessor communication (IPC) peripheral is used to send and receive events between MCUs in the system.

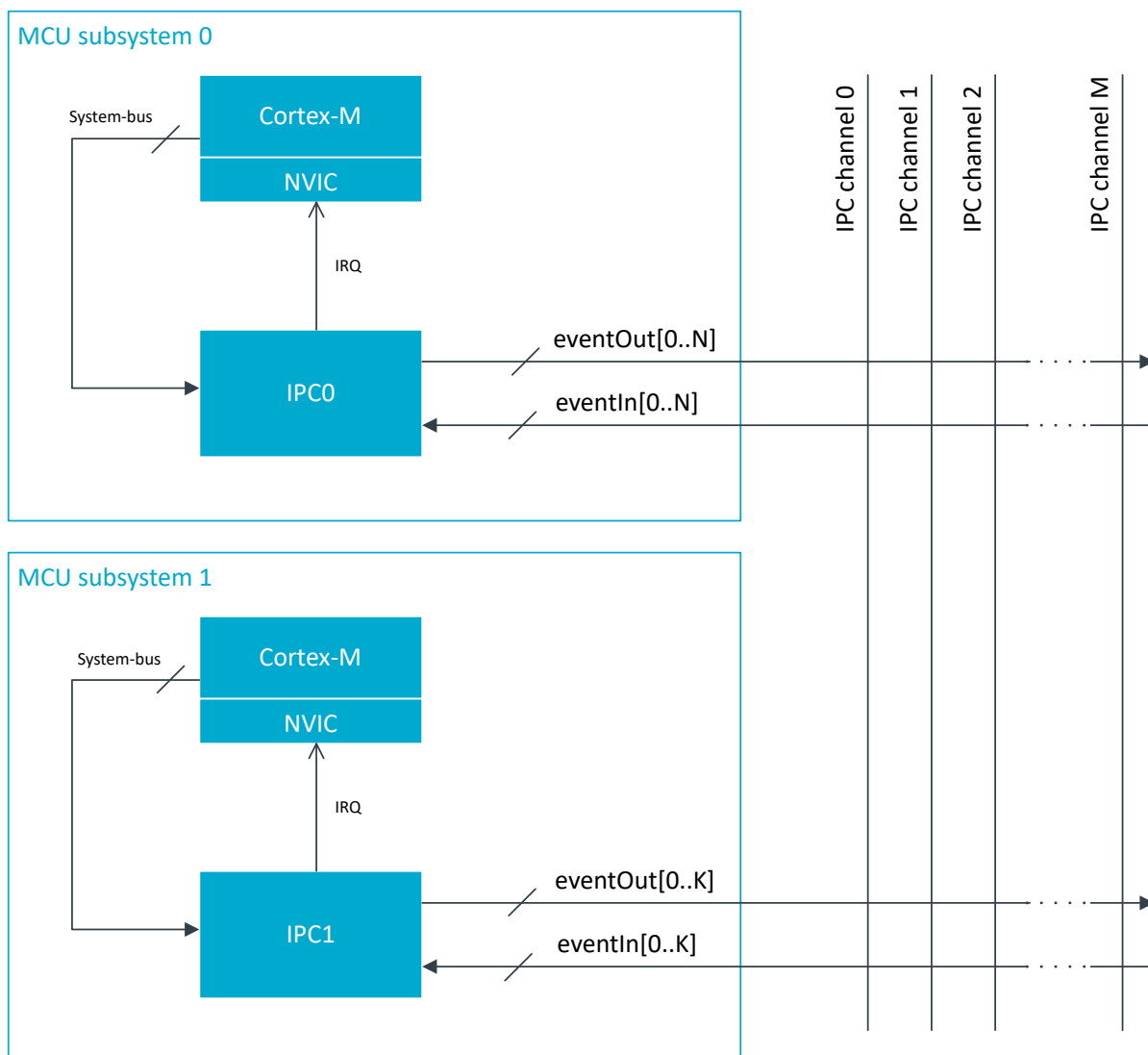

Figure 25: IPC block diagram

Functional description

[IPC block diagram](#) on page 181 illustrates the interprocessor communication (IPC) peripheral. In a multi-MCU system, each MCU has one dedicated IPC peripheral. The IPC peripheral can be used to send and receive events to and from other IPC peripherals. An instance of the IPC peripheral can have multiple SEND tasks and RECEIVE events. A single SEND task can be configured to signal an event on one or more IPC channels, and a RECEIVE event can be configured to listen on one or more IPC channels. The IPC channels that are triggered in a SEND task can be configured through the [SEND_CNF](#) registers, and the IPC channels that trigger a RECEIVE event are configured through the [RECEIVE_CNF](#) registers. The figure below illustrates how the [SEND_CNF](#) and [RECEIVE_CNF](#) registers work. Both the SEND task and the RECEIVE event can be connected to all IPC channels.

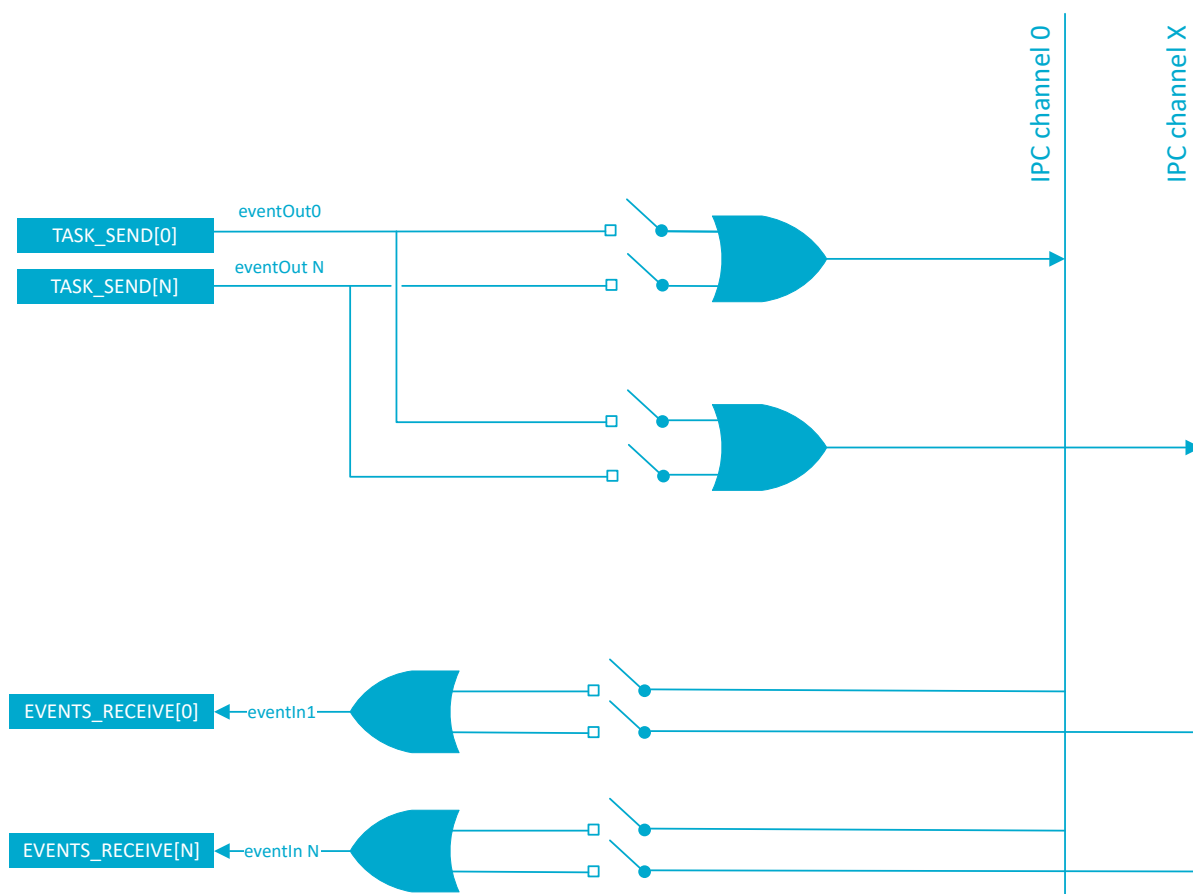

Figure 26: IPC registers *SEND_CNF* and *RECEIVE_CNF*

A SEND task can be viewed as broadcasting events onto one or more IPC channels, and a RECEIVE event can be seen as subscribing to a subset of IPC channels. It is possible for multiple IPCs to trigger events onto the same channel at the same time. When two or more events on the same channel occur within t_{IPC} , the events may be merged into a single event seen from the IPC receiver. One of the events can therefore be lost. To prevent this, the user must ensure that events on the same IPC channel do not occur within t_{IPC} of each other. When implementing firmware data structures, such as queues or mailboxes, this can be done by using one channel for acknowledgements.

An IPC event often does not contain any data itself, it is used to signal other MCUs that something has occurred. Data can be shared through shared memory, for example in the form of a software implemented mailbox, or command/event queues. It is up to software to assign a logical functionality to an IPC channel. For instance, one IPC channel can be used to signal that a command is ready to be executed, and any processor in the system can subscribe to that particular channel and decode/execute the command.

General purpose memory

The **GPMEM** registers can be used freely to store information. These registers are accessed like any other of the IPC peripheral's registers.

6.6.1 IPC and PPI connections

The IPC SEND tasks and RECEIVE events can be connected through PPI channels. This makes it possible to relay events from peripherals in one MCU to another, without CPU involvement.

Figure below illustrates a timer COMPARE event that is relayed from one MCU to IPC using PPI, then back into a timer CAPTURE event in another MCU.

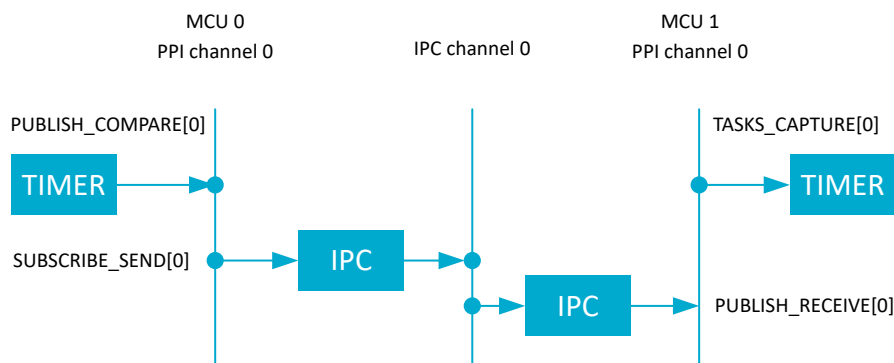

Figure 27: Example of PPI and IPC connections

6.6.2 Registers

Instances

Instance	Base address	TrustZone			Split access	Description
		Map	Att	DMA		
IPC : S	0x5002A000	US	NS	NA	No	Interprocessor communication
IPC : NS	0x4002A000					

Register overview

Register	Offset	TZ	Description
TASKS_SEND[n]	0x000		Trigger events on IPC channel enabled in SEND_CNF[n]
SUBSCRIBE_SEND[n]	0x080		Subscribe configuration for task SEND[n]
EVENTS_RECEIVE[n]	0x100		Event received on one or more of the enabled IPC channels in RECEIVE_CNF[n]
PUBLISH_RECEIVE[n]	0x180		Publish configuration for event RECEIVE[n]
INTEN	0x300		Enable or disable interrupt
INTENSET	0x304		Enable interrupt
INTENCLR	0x308		Disable interrupt
INTPEND	0x30C		Pending interrupts
SEND_CNF[n]	0x510		Send event configuration for TASKS_SEND[n]
RECEIVE_CNF[n]	0x590		Receive event configuration for EVENTS_RECEIVE[n]
GPMEM[n]	0x610		General purpose memory

6.6.2.1 TASKS_SEND[n] (n=0..7)

Address offset: 0x000 + (n × 0x4)

Trigger events on IPC channel enabled in SEND_CNF[n]

Bit number	31 30 29 28 27 26 25 24 23 22 21 20 19 18 17 16 15 14 13 12 11 10 9 8 7 6 5 4 3 2 1 0																														
ID	A																														
Reset 0x00000000	0 0																														
ID	R/W	Field	Value ID	Value	Description																										
A	W	TASKS_SEND	Trigger	1	Trigger events on IPC channel enabled in SEND_CNF[n] Trigger task																										

6.6.2.2 SUBSCRIBE_SEND[n] (n=0..7)

Address offset: $0x080 + (n \times 0x4)$

Subscribe configuration for task SEND[n]

Bit number	31 30 29 28 27 26 25 24 23 22 21 20 19 18 17 16 15 14 13 12 11 10 9 8 7 6 5 4 3 2 1 0																																																										
ID	B																												A			A		A		A		A		A		A		A		A		A		A		A		A		A		A	
Reset 0x00000000	0 0																																																										
ID	R/W	Field	Value ID	Value	Description																																																						
A	RW	CHIDX		[0..255]	DPPI channel that task SEND[n] will subscribe to																																																						
B	RW	EN	Disabled	0	Disable subscription																																																						
			Enabled	1	Enable subscription																																																						

6.6.2.3 EVENTS_RECEIVE[n] (n=0..7)

Address offset: $0x100 + (n \times 0x4)$

Event received on one or more of the enabled IPC channels in RECEIVE_CNF[n]

Bit number	31 30 29 28 27 26 25 24 23 22 21 20 19 18 17 16 15 14 13 12 11 10 9 8 7 6 5 4 3 2 1 0																															
ID																															A	
Reset 0x00000000	0 0																															
ID	R/W	Field	Value ID	Value	Description																											
A	RW	EVENTS_RECEIVE			Event received on one or more of the enabled IPC channels in RECEIVE_CNF[n]																											
			NotGenerated	0	Event not generated																											
			Generated	1	Event generated																											

6.6.2.4 PUBLISH_RECEIVE[n] (n=0..7)

Address offset: $0x180 + (n \times 0x4)$

Publish configuration for event RECEIVE[n]

Bit number	31 30 29 28 27 26 25 24 23 22 21 20 19 18 17 16 15 14 13 12 11 10 9 8 7 6 5 4 3 2 1 0																																																								
ID	B																												A			A		A		A		A		A		A		A		A		A		A		A		A		A	
Reset 0x00000000	0 0																																																								
ID	R/W	Field	Value ID	Value	Description																																																				
A	RW	CHIDX		[0..255]	DPPI channel that event RECEIVE[n] will publish to																																																				
B	RW	EN	Disabled	0	Disable publishing																																																				
			Enabled	1	Enable publishing																																																				

6.6.2.5 INTEN

Address offset: 0x300

Enable or disable interrupt

Bit number	31	30	29	28	27	26	25	24	23	22	21	20	19	18	17	16	15	14	13	12	11	10	9	8	7	6	5	4	3	2	1	0		
ID																											H	G	F	E	D	C	B	A
Reset 0x00000000	0 0																																	
ID	R/W	Field	Value ID	Value	Description																													
A-H	RW	RECEIVE[i] (i=0..7)			Enable or disable interrupt for event RECEIVE[i]																													
			Disabled	0	Disable																													
			Enabled	1	Enable																													

6.6.2.6 INTENSET

Address offset: 0x304

Enable interrupt

Bit number	31	30	29	28	27	26	25	24	23	22	21	20	19	18	17	16	15	14	13	12	11	10	9	8	7	6	5	4	3	2	1	0		
ID																											H	G	F	E	D	C	B	A
Reset 0x00000000	0 0																																	
ID	R/W	Field	Value ID	Value	Description																													
A-H	RW	RECEIVE[i] (i=0..7)			Write '1' to enable interrupt for event RECEIVE[i]																													
			Set	1	Enable																													
			Disabled	0	Read: Disabled																													
			Enabled	1	Read: Enabled																													

6.6.2.7 INTENCLR

Address offset: 0x308

Disable interrupt

Bit number	31	30	29	28	27	26	25	24	23	22	21	20	19	18	17	16	15	14	13	12	11	10	9	8	7	6	5	4	3	2	1	0		
ID																											H	G	F	E	D	C	B	A
Reset 0x00000000	0 0																																	
ID	R/W	Field	Value ID	Value	Description																													
A-H	RW	RECEIVE[i] (i=0..7)			Write '1' to disable interrupt for event RECEIVE[i]																													
			Clear	1	Disable																													
			Disabled	0	Read: Disabled																													
			Enabled	1	Read: Enabled																													

6.6.2.8 INTPEND

Address offset: 0x30C

Pending interrupts

Bit number	31	30	29	28	27	26	25	24	23	22	21	20	19	18	17	16	15	14	13	12	11	10	9	8	7	6	5	4	3	2	1	0		
ID																											H	G	F	E	D	C	B	A
Reset 0x00000000	0 0																																	
ID	R/W	Field	Value ID	Value	Description																													
A-H	R	RECEIVE[i] (i=0..7)			Read pending status of interrupt for event RECEIVE[i]																													
			NotPending	0	Read: Not pending																													
			Pending	1	Read: Pending																													

6.6.2.9 SEND_CNF[n] (n=0..7)

Address offset: 0x510 + (n × 0x4)

Send event configuration for TASKS_SEND[n]

Bit number	31 30 29 28 27 26 25 24 23 22 21 20 19 18 17 16 15 14 13 12 11 10 9 8 7 6 5 4 3 2 1 0																																			
ID																													H	G	F	E	D	C	B	A
Reset 0x00000000	0 0																																			
ID	R/W	Field	Value ID	Value	Description																															
A-H	RW	CHEN[i] (i=0..7)			Enable broadcasting on IPC channel i																															
			Disable	0	Disable broadcast																															
			Enable	1	Enable broadcast																															

6.6.2.10 RECEIVE_CNF[n] (n=0..7)

Address offset: 0x590 + (n × 0x4)

Receive event configuration for EVENTS_RECEIVE[n]

Bit number	31 30 29 28 27 26 25 24 23 22 21 20 19 18 17 16 15 14 13 12 11 10 9 8 7 6 5 4 3 2 1 0																																			
ID																													H	G	F	E	D	C	B	A
Reset 0x00000000	0 0																																			
ID	R/W	Field	Value ID	Value	Description																															
A-H	RW	CHEN[i] (i=0..7)			Enable subscription to IPC channel i																															
			Disable	0	Disable events																															
			Enable	1	Enable events																															

6.6.2.11 GPMEM[n] (n=0..3)

Address offset: 0x610 + (n × 0x4)

General purpose memory

Retained only in System ON mode

Bit number	31 30 29 28 27 26 25 24 23 22 21 20 19 18 17 16 15 14 13 12 11 10 9 8 7 6 5 4 3 2 1 0																																																								
ID	A																												A	A	A	A	A	A	A	A	A	A	A	A	A	A	A	A	A	A	A	A	A	A	A	A	A	A	A	A	A
Reset 0x00000000	0 0																																																								
ID	R/W	Field	Value ID	Value	Description																																																				
A	RW	GPMEM			General purpose memory																																																				

6.6.3 Electrical specification

6.6.3.1 IPC Electrical Specification

Symbol	Description	Min.	Typ.	Max.	Units
t _{IPC}	Time window during which IPC events can be merged			165	µs

6.7 I2S — Inter-IC sound interface

The I2S (Inter-IC Sound) module, supports the original two-channel I2S format, and left or right-aligned formats. It implements EasyDMA for sample transfer directly to and from RAM without CPU intervention.

The I2S peripheral has the following main features:

- Master and Slave mode

- Simultaneous bi-directional (TX and RX) audio streaming
- Original I2S and left- or right-aligned format
- 8, 16 and 24-bit sample width
- Low-jitter Master Clock generator
- Various sample rates

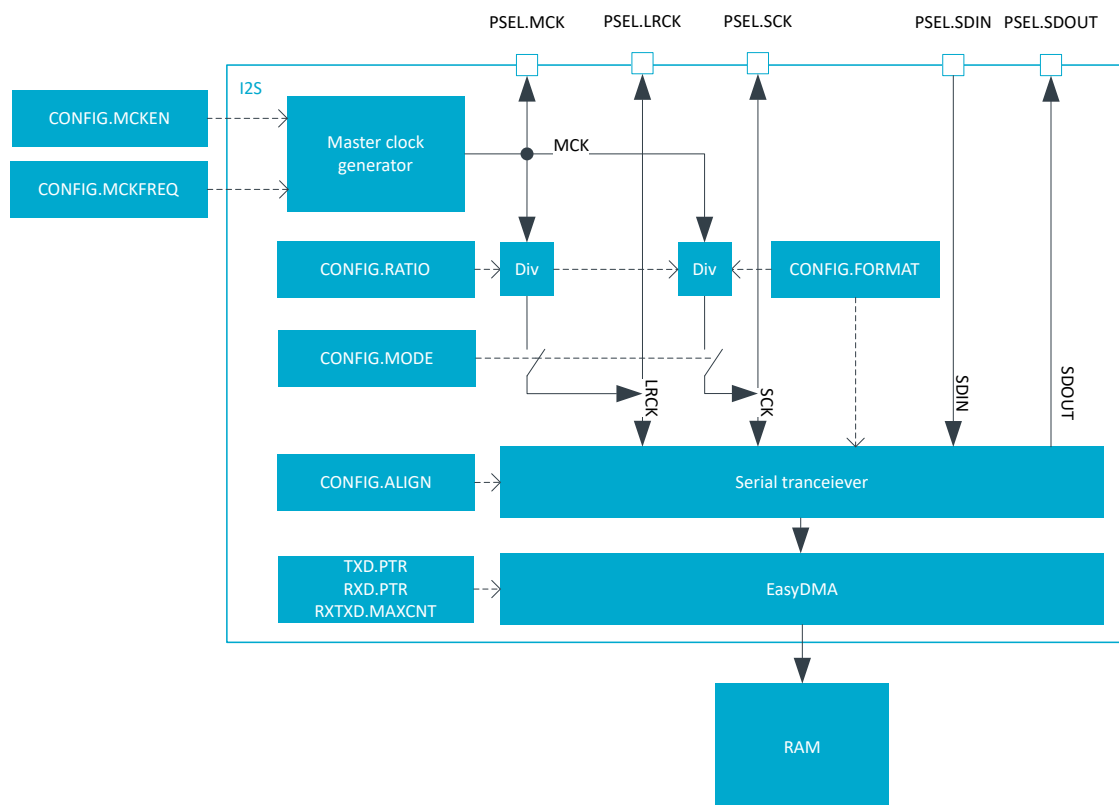

Figure 28: I2S master

6.7.1 Mode

The I2S protocol specification defines two modes of operation, Master and Slave.

The I2S mode decides which of the two sides (Master or Slave) shall provide the clock signals LRCK and SCK, and these signals are always supplied by the Master to the Slave.

6.7.2 Transmitting and receiving

The I2S module supports both transmission (TX) and reception (RX) of serial data. In both cases the serial data is shifted synchronously to the clock signals SCK and LRCK.

TX data is written to the SDOUT pin on the falling edge of SCK, and RX data is read from the SDIN pin on the rising edge of SCK. The most significant bit (MSB) is always transmitted first.

Note: When starting a transmission in master mode, two frames (two left-and-right sample pairs) of value zero will be transmitted after triggering the START task, prior to the RXTX.MAXCNT samples specified by the TXD.PTR pointer.

TX and RX are available in both Master and Slave modes and can be enabled/disabled independently in the [CONFIG.TXEN](#) on page 201 and [CONFIG.RXEN](#) on page 201.

Transmission and/or reception is started by triggering the START task. When started and transmission is enabled (in [CONFIG.TXEN](#) on page 201), the TXPTRUPD event will be generated for every

RXTXD.MAXCNT on page 204 number of transmitted data words (containing one or more samples). Similarly, when started and reception is enabled (in **CONFIG.RXEN** on page 201), the **RXPTRUPD** event will be generated for every **RXTXD.MAXCNT** on page 204 received data words.

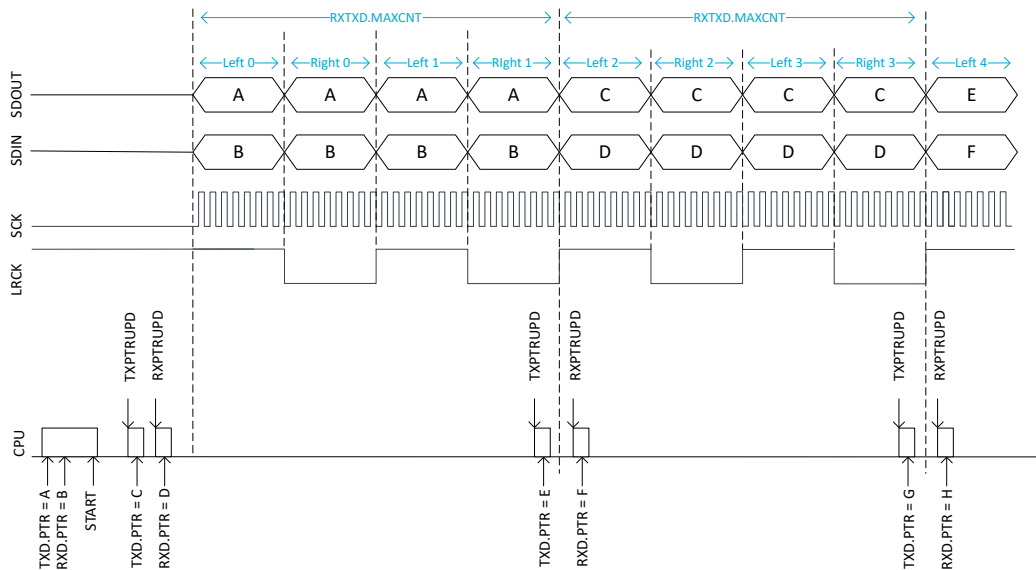

Figure 29: Transmitting and receiving. *CONFIG.FORMAT = Aligned, CONFIG.SWIDTH = 8Bit, CONFIG.CHANNELS = Stereo, RXTXD.MAXCNT = 1.*

6.7.3 Left right clock (LRCK)

The Left Right Clock (LRCK), often referred to as "word clock", "sample clock" or "word select" in I2S context, is the clock defining the frames in the serial bit streams sent and received on SDOUT and SDIN, respectively.

In I2S mode, each frame contains one left and right sample pair, with the left sample being transferred during the low half period of LRCK followed by the right sample being transferred during the high period of LRCK.

In Aligned mode, each frame contains one left and right sample pair, with the left sample being transferred during the high half period of LRCK followed by the right sample being transferred during the low period of LRCK.

Consequently, the LRCK frequency is equivalent to the audio sample rate.

When operating in Master mode, the LRCK is generated from the MCK, and the frequency of LRCK is then given as:

$$\text{LRCK} = \text{MCK} / \text{CONFIG.RATIO}$$

LRCK always toggles around the falling edge of the serial clock SCK.

6.7.4 Serial clock (SCK)

The serial clock (SCK), often referred to as the serial bit clock, pulses once for each data bit being transferred on the serial data lines SDIN and SDOUT.

When operating in Master mode the SCK is generated from the MCK, and the frequency of SCK is then given as:

$$\text{SCK} = 2 * \text{LRCK} * \text{CONFIG.SWIDTH}$$

The falling edge of the SCK falls on the toggling edge of LRCK.

When operating in Slave mode SCK is provided by the external I2S master.

6.7.5 Master clock (MCK)

The master clock (MCK) is the clock from which LRCK and SCK are derived when operating in Master mode.

The MCK is generated by an internal MCK generator. This generator always needs to be enabled when in Master mode, but the generator can also be enabled when in Slave mode. Enabling the generator when in slave mode can be useful in the case where the external Master is not able to generate its own master clock.

The MCK generator is enabled/disabled in the register `CONFIG.MCKEN` on page 201, and the generator is started or stopped by the START or STOP tasks.

In Master mode the LRCK and the SCK frequencies are closely related, as both are derived from MCK and set indirectly through `CONFIG.RATIO` on page 202 and `CONFIG.SWIDTH` on page 203.

When configuring these registers, the user is responsible for fulfilling the following requirements:

1. SCK frequency can never exceed the MCK frequency, which can be formulated as:

$$\text{CONFIG.RATIO} \geq 2 * \text{CONFIG.SWIDTH}$$

2. The MCK/LRCK ratio shall be a multiple of $2 * \text{CONFIG.SWIDTH}$, which can be formulated as:

$$\text{Integer} = (\text{CONFIG.RATIO} / (2 * \text{CONFIG.SWIDTH}))$$

The MCK signal can be routed to an output pin (specified in `PSEL.MCK`) to supply external I2S devices that require the MCK to be supplied from the outside.

When operating in Slave mode, the I2S module does not use the MCK and the MCK generator does not need to be enabled.

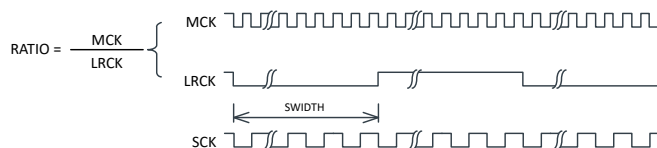

Figure 30: Relation between *RATIO*, *MCK* and *LRCK*.

Desired LRCK [Hz]	CONFIG.SWID	CONFIG.RATIO	CONFIG.MCKF	MCK [Hz]	LRCK [Hz]	LRCK error [%]
16000	16Bit	32X	32MDIV63	507936.5	15873.0	-0.8
16000	16Bit	64X	32MDIV31	1032258.1	16129.0	0.8
16000	16Bit	256X	32MDIV8	4000000.0	15625.0	-2.3
32000	16Bit	32X	32MDIV31	1032258.1	32258.1	0.8
32000	16Bit	64X	32MDIV16	2000000.0	31250.0	-2.3
44100	16Bit	32X	32MDIV23	1391304.3	43478.3	-1.4
44100	16Bit	64X	32MDIV11	2909090.9	45454.5	3.1

Table 20: Configuration examples

6.7.6 Width, alignment, and format

The CONFIG.SWIDTH register primarily defines the sample width of the data written to memory. In master mode, it then also sets the amount of bits per frame. In Slave mode it controls padding/trimming if required. Left, right, transmitted, and received samples always have the same width. The CONFIG.FORMAT register specifies the position of the data frames with respect to the LRCK edges in both Master and Slave modes.

When using I2S format, the first bit in a half-frame (containing one left or right sample) gets sampled on the second rising edge of the SCK after a LRCK edge. When using Aligned mode, the first bit in a half-frame gets sampled on the first rising edge of SCK following a LRCK edge.

For data being received on SDIN the sample value can be either right or left-aligned inside a half-frame, as specified in CONFIG.ALIGN on page 203. CONFIG.ALIGN on page 203 affects only the decoding of the incoming samples (SDIN), while the outgoing samples (SDOUT) are always left-aligned (or justified).

When using left-alignment, each half-frame starts with the MSB of the sample value (both for data being sent on SDOUT and received on SDIN).

When using right-alignment, each half-frame of data being received on SDIN ends with the LSB of the sample value, while each half-frame of data being sent on SDOUT starts with the MSB of the sample value (same as for left-alignment).

In Master mode, the size of a half-frame (in number of SCK periods) equals the sample width (in number of bits), and in this case the alignment setting does not care as each half-frame in any case will start with the MSB and end with the LSB of the sample value.

In slave mode, however, the sample width does not need to equal the frame size. This means you might have extra or fewer SCK pulses per half-frame than what the sample width specified in CONFIG.SWIDTH requires.

In the case where we use **left-alignment** and the number of SCK pulses per half-frame is **higher** than the sample width, the following will apply:

- For data received on SDIN, all bits after the LSB of the sample value will be discarded.
- For data sent on SDOUT, all bits after the LSB of the sample value will be 0.

In the case where we use **left-alignment** and the number of SCK pulses per frame is **lower** than the sample width, the following will apply:

- Data sent and received on SDOUT and SDIN will be truncated with the LSBs being removed first.

In the case where we use **right-alignment** and the number of SCK pulses per frame is **higher** than the sample width, the following will apply:

- For data received on SDIN, all bits before the MSB of the sample value will be discarded.
- For data sent on SDOUT, all bits after the LSB of the sample value will be 0 (same behavior as for left-alignment).

In the case where we use **right-alignment** and the number of SCK pulses per frame is **lower** than the sample width, the following will apply:

- Data received on SDIN will be sign-extended to "sample width" number of bits before being written to memory.
- Data sent on SDOUT will be truncated with the LSBs being removed first (same behavior as for left-alignment).

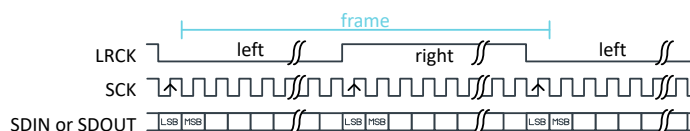

Figure 31: I2S format. CONFIG.SWIDTH equaling half-frame size.

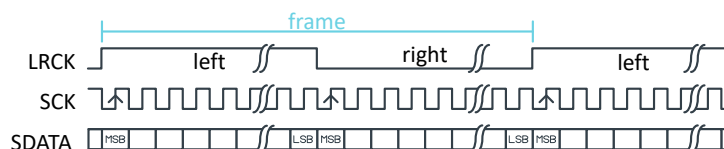

Figure 32: Aligned format. *CONFIG.SWIDTH* equaling half-frame size.

6.7.7 EasyDMA

The I2S module implements EasyDMA for accessing internal Data RAM without CPU intervention.

The source and destination pointers for the TX and RX data are configured in [TXD.PTR](#) on page 204 and [RXD.PTR](#) on page 204. The memory pointed to by these pointers will only be read or written when TX or RX are enabled in [CONFIG.TXEN](#) on page 201 and [CONFIG.RXEN](#) on page 201.

The addresses written to the pointer registers [TXD.PTR](#) on page 204 and [RXD.PTR](#) on page 204 are double-buffered in hardware, and these double buffers are updated for every [RXTXD.MAXCNT](#) on page 204 words (containing one or more samples) read/written from/to memory. The events [TXPTRUPD](#) and [RXPTRUPD](#) are generated whenever the [TXD.PTR](#) and [RXD.PTR](#) are transferred to these double buffers.

If [TXD.PTR](#) on page 204 is not pointing to the Data RAM region when transmission is enabled, or [RXD.PTR](#) on page 204 is not pointing to the Data RAM region when reception is enabled, an EasyDMA transfer may result in a HardFault and/or memory corruption. See [Memory](#) on page 23 for more information about the different memory regions.

Due to the nature of I2S, where the number of transmitted samples always equals the number of received samples (at least when both TX and RX are enabled), one common register [RXTXD.MAXCNT](#) on page 204 is used for specifying the sizes of these two memory buffers. The size of the buffers is specified in a number of 32-bit words. Such a 32-bit memory word can either contain four 8-bit samples, two 16-bit samples or one right-aligned 24-bit sample sign extended to 32 bit.

In stereo mode ([CONFIG.CHANNELS](#)=Stereo), the samples are stored as "left and right sample pairs" in memory. Figure [Memory mapping for 8 bit stereo. CONFIG.SWIDTH = 8Bit, CONFIG.CHANNELS = Stereo.](#) on page 191, [Memory mapping for 16 bit stereo. CONFIG.SWIDTH = 16Bit, CONFIG.CHANNELS = Stereo.](#) on page 192 and [Memory mapping for 24 bit stereo. CONFIG.SWIDTH = 24Bit, CONFIG.CHANNELS = Stereo.](#) on page 192 show how the samples are mapped to memory in this mode. The mapping is valid for both RX and TX.

In mono mode ([CONFIG.CHANNELS](#)=Left or Right), RX sample from only one channel in the frame is stored in memory, the other channel sample is ignored. Illustrations [Memory mapping for 8 bit mono. CONFIG.SWIDTH = 8Bit, CONFIG.CHANNELS = Left.](#) on page 192, [Memory mapping for 16 bit mono, left channel only. CONFIG.SWIDTH = 16Bit, CONFIG.CHANNELS = Left.](#) on page 192 and [Memory mapping for 24 bit mono, left channel only. CONFIG.SWIDTH = 24Bit, CONFIG.CHANNELS = Left.](#) on page 193 show how RX samples are mapped to memory in this mode.

For TX, the same outgoing sample read from memory is transmitted on both left and right in a frame, resulting in a mono output stream.

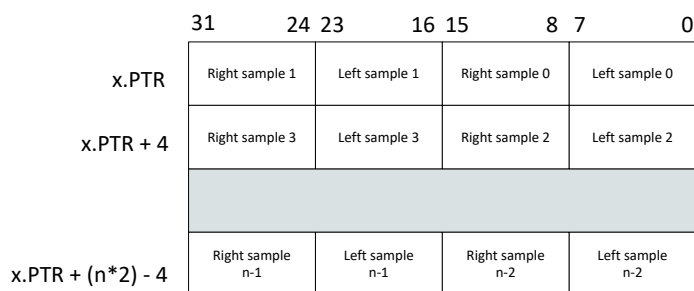

Figure 33: Memory mapping for 8 bit stereo. *CONFIG.SWIDTH* = 8Bit, *CONFIG.CHANNELS* = Stereo.

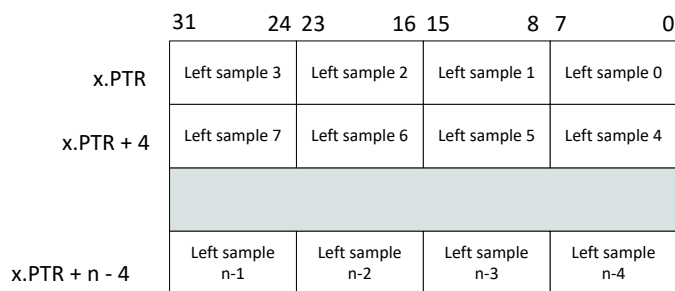

Figure 34: Memory mapping for 8 bit mono. CONFIG.SWIDTH = 8Bit, CONFIG.CHANNELS = Left.

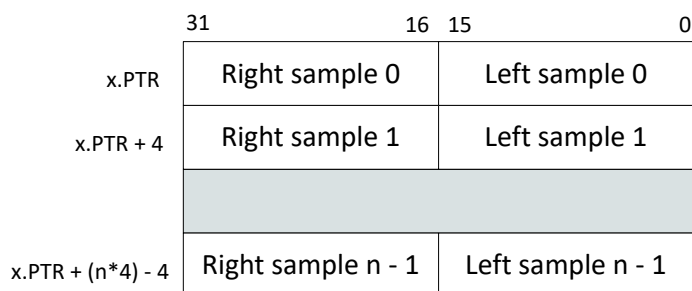

Figure 35: Memory mapping for 16 bit stereo. CONFIG.SWIDTH = 16Bit, CONFIG.CHANNELS = Stereo.

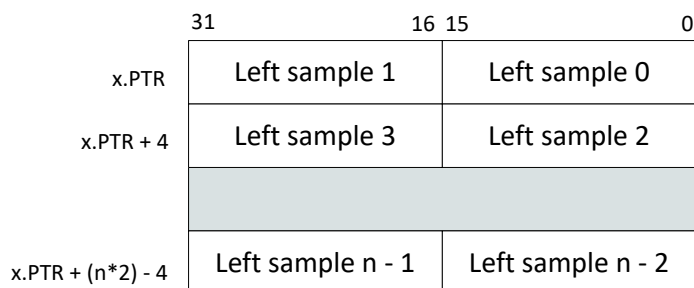

Figure 36: Memory mapping for 16 bit mono, left channel only. CONFIG.SWIDTH = 16Bit, CONFIG.CHANNELS = Left.

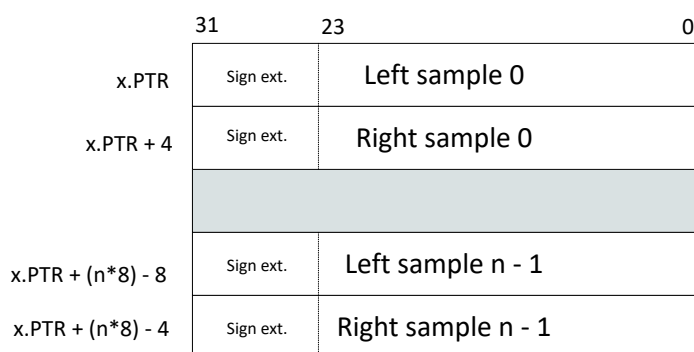

Figure 37: Memory mapping for 24 bit stereo. CONFIG.SWIDTH = 24Bit, CONFIG.CHANNELS = Stereo.

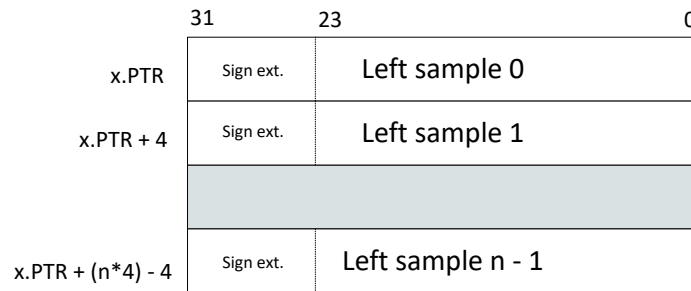

Figure 38: Memory mapping for 24 bit mono, left channel only. CONFIG.SWIDTH = 24Bit, CONFIG.CHANNELS = Left.

6.7.8 Module operation

Described here is a typical operating procedure for the I2S module.

1. Configure the I2S module using the CONFIG registers

```
// Enable reception
NRF_I2S->CONFIG.RXEN = (I2S_CONFIG_RXEN_RXEN_Enabled <<
                        I2S_CONFIG_RXEN_RXEN_Pos);

// Enable transmission
NRF_I2S->CONFIG.TXEN = (I2S_CONFIG_TXEN_TXEN_Enabled <<
                        I2S_CONFIG_TXEN_TXEN_Pos);

// Enable MCK generator
NRF_I2S->CONFIG.MCKEN = (I2S_CONFIG_MCKEN_MCKEN_Enabled <<
                          I2S_CONFIG_MCKEN_MCKEN_Pos);

// MCKFREQ = 4 MHz
NRF_I2S->CONFIG.MCKFREQ = I2S_CONFIG_MCKFREQ_MCKFREQ_32MDIV8 <<
                          I2S_CONFIG_MCKFREQ_MCKFREQ_Pos;

// Ratio = 256
NRF_I2S->CONFIG.RATIO = I2S_CONFIG_RATIO_RATIO_256X <<
                       I2S_CONFIG_RATIO_RATIO_Pos;

// MCKFREQ = 4 MHz and Ratio = 256 gives sample rate = 15.625 ks/s
// Sample width = 16 bit
NRF_I2S->CONFIG.SWIDTH = I2S_CONFIG_SWIDTH_SWIDTH_16Bit <<
                        I2S_CONFIG_SWIDTH_SWIDTH_Pos;

// Alignment = Left
NRF_I2S->CONFIG.ALIGN = I2S_CONFIG_ALIGN_ALIGN_Left <<
                       I2S_CONFIG_ALIGN_ALIGN_Pos;

// Format = I2S
NRF_I2S->CONFIG.FORMAT = I2S_CONFIG_FORMAT_FORMAT_I2S <<
                        I2S_CONFIG_FORMAT_FORMAT_Pos;

// Use stereo
NRF_I2S->CONFIG.CHANNELS = I2S_CONFIG_CHANNELS_CHANNELS_Stereo <<
                          I2S_CONFIG_CHANNELS_CHANNELS_Pos;
```

2. Map IO pins using the PINSEL registers

```

// MCK routed to pin 0
NRF_I2S->PSEL.MCK = (0 << I2S_PSEL_MCK_PIN_Pos) |
                    (I2S_PSEL_MCK_CONNECT_Connected <<
                     I2S_PSEL_MCK_CONNECT_Pos);

// SCK routed to pin 1
NRF_I2S->PSEL.SCK = (1 << I2S_PSEL_SCK_PIN_Pos) |
                    (I2S_PSEL_SCK_CONNECT_Connected <<
                     I2S_PSEL_SCK_CONNECT_Pos);

// LRCK routed to pin 2
NRF_I2S->PSEL.LRCK = (2 << I2S_PSEL_LRCK_PIN_Pos) |
                     (I2S_PSEL_LRCK_CONNECT_Connected <<
                      I2S_PSEL_LRCK_CONNECT_Pos);

// SDOUT routed to pin 3
NRF_I2S->PSEL.SDOUT = (3 << I2S_PSEL_SDOUT_PIN_Pos) |
                      (I2S_PSEL_SDOUT_CONNECT_Connected <<
                       I2S_PSEL_SDOUT_CONNECT_Pos);

// SDIN routed on pin 4
NRF_I2S->PSEL.SDIN = (4 << I2S_PSEL_SDIN_PIN_Pos) |
                     (I2S_PSEL_SDIN_CONNECT_Connected <<
                      I2S_PSEL_SDIN_CONNECT_Pos);

```

3. Configure TX and RX data pointers using the TXD, RXD and RXTXD registers

```

NRF_I2S->TXD.PTR = my_tx_buf;
NRF_I2S->RXD.PTR = my_rx_buf;
NRF_I2S->TXD.MAXCNT = MY_BUF_SIZE;

```

4. Enable the I2S module using the ENABLE register

```

NRF_I2S->ENABLE = 1;

```

5. Start audio streaming using the START task

```

NRF_I2S->TASKS_START = 1;

```

6. Handle received and transmitted data when receiving the TXPTRUPD and RXPTRUPD events

```

if(NRF_I2S->EVENTS_TXPTRUPD != 0)
{
    NRF_I2S->TXD.PTR = my_next_tx_buf;
    NRF_I2S->EVENTS_TXPTRUPD = 0;
}

if(NRF_I2S->EVENTS_RXPTRUPD != 0)
{
    NRF_I2S->RXD.PTR = my_next_rx_buf;
    NRF_I2S->EVENTS_RXPTRUPD = 0;
}

```

6.7.9 Pin configuration

The MCK, SCK, LRCK, SDIN and SDOOUT signals associated with the I2S module are mapped to physical pins according to the pin numbers specified in the PSEL.x registers.

These pins are acquired whenever the I2S module is enabled through the register [ENABLE](#) on page 200.

When a pin is acquired by the I2S module, the direction of the pin (input or output) will be configured automatically, and any pin direction setting done in the GPIO module will be overridden. The directions for the various I2S pins are shown below in [GPIO configuration before enabling peripheral \(master mode\)](#) on page 195 and [GPIO configuration before enabling peripheral \(slave mode\)](#) on page 195.

To secure correct signal levels on the pins when the system is in OFF mode, and when the I2S module is disabled, these pins must be configured in the GPIO peripheral directly.

I2S signal	I2S pin	Direction	Output value	Comment
MCK	As specified in PSEL.MCK	Output	0	
LRCK	As specified in PSEL.LRCK	Output	0	
SCK	As specified in PSEL.SCK	Output	0	
SDIN	As specified in PSEL.SDIN	Input	Not applicable	
SDOOUT	As specified in PSEL.SDOOUT	Output	0	

Table 21: GPIO configuration before enabling peripheral (master mode)

I2S signal	I2S pin	Direction	Output value	Comment
MCK	As specified in PSEL.MCK	Output	0	
LRCK	As specified in PSEL.LRCK	Input	Not applicable	
SCK	As specified in PSEL.SCK	Input	Not applicable	
SDIN	As specified in PSEL.SDIN	Input	Not applicable	
SDOOUT	As specified in PSEL.SDOOUT	Output	0	

Table 22: GPIO configuration before enabling peripheral (slave mode)

6.7.10 Registers

Instances

Instance	Base address	TrustZone			Split access	Description
		Map	Att	DMA		
I2S : S	0x50028000	US	NS	SA	No	Inter-IC Sound
I2S : NS	0x40028000					

Register overview

Register	Offset	TZ	Description
TASKS_START	0x000		Starts continuous I2S transfer. Also starts MCK generator when this is enabled.
TASKS_STOP	0x004		Stops I2S transfer. Also stops MCK generator. Triggering this task will cause the STOPPED event to be generated.
SUBSCRIBE_START	0x080		Subscribe configuration for task START
SUBSCRIBE_STOP	0x084		Subscribe configuration for task STOP
EVENTS_RXPTRUPD	0x104		The RXD.PTR register has been copied to internal double-buffers. When the I2S module is started and RX is enabled, this event will be generated for every RXTXD.MAXCNT words that are received on the SDIN pin.

Register	Offset	TZ	Description
EVENTS_STOPPED	0x108		I2S transfer stopped.
EVENTS_TXPTRUPD	0x114		The TDX.PTR register has been copied to internal double-buffers. When the I2S module is started and TX is enabled, this event will be generated for every RXTXD.MAXCNT words that are sent on the SDOOUT pin.
PUBLISH_RXPTRUPD	0x184		Publish configuration for event RXPTRUPD
PUBLISH_STOPPED	0x188		Publish configuration for event STOPPED
PUBLISH_TXPTRUPD	0x194		Publish configuration for event TXPTRUPD
INTEN	0x300		Enable or disable interrupt
INTENSET	0x304		Enable interrupt
INTENCLR	0x308		Disable interrupt
ENABLE	0x500		Enable I2S module.
CONFIG.MODE	0x504		I2S mode.
CONFIG.RXEN	0x508		Reception (RX) enable.
CONFIG.TXEN	0x50C		Transmission (TX) enable.
CONFIG.MCKEN	0x510		Master clock generator enable.
CONFIG.MCKFREQ	0x514		Master clock generator frequency.
CONFIG.RATIO	0x518		MCK / LRCK ratio.
CONFIG.SWIDTH	0x51C		Sample width.
CONFIG.ALIGN	0x520		Alignment of sample within a frame.
CONFIG.FORMAT	0x524		Frame format.
CONFIG.CHANNELS	0x528		Enable channels.
RXD.PTR	0x538		Receive buffer RAM start address.
TXD.PTR	0x540		Transmit buffer RAM start address.
RXTXD.MAXCNT	0x550		Size of RXD and TXD buffers.
PSEL.MCK	0x560		Pin select for MCK signal.
PSEL.SCK	0x564		Pin select for SCK signal.
PSEL.LRCK	0x568		Pin select for LRCK signal.
PSEL.SDIN	0x56C		Pin select for SDIN signal.
PSEL.SDOUT	0x570		Pin select for SDOOUT signal.

6.7.10.1 TASKS_START

Address offset: 0x000

Starts continuous I2S transfer. Also starts MCK generator when this is enabled.

Bit number	31 30 29 28 27 26 25 24 23 22 21 20 19 18 17 16 15 14 13 12 11 10 9 8 7 6 5 4 3 2 1 0																															
ID																																A
Reset 0x00000000	0 0																															
ID	R/W	Field	Value ID	Value	Description																											
A	W	TASKS_START			Starts continuous I2S transfer. Also starts MCK generator when this is enabled.																											
			Trigger	1	Trigger task																											

6.7.10.2 TASKS_STOP

Address offset: 0x004

Stops I2S transfer. Also stops MCK generator. Triggering this task will cause the [STOPPED](#) event to be generated.

Bit number	31	30	29	28	27	26	25	24	23	22	21	20	19	18	17	16	15	14	13	12	11	10	9	8	7	6	5	4	3	2	1	0
ID																																A
Reset 0x00000000	0 0																															
ID	R/W	Field	Value ID	Value	Description																											
A	W	TASKS_STOP			Stops I2S transfer. Also stops MCK generator. Triggering this task will cause the STOPPED event to be generated.																											
			Trigger	1	Trigger task																											

6.7.10.3 SUBSCRIBE_START

Address offset: 0x080

Subscribe configuration for task **START**

Bit number	31	30	29	28	27	26	25	24	23	22	21	20	19	18	17	16	15	14	13	12	11	10	9	8	7	6	5	4	3	2	1	0													
ID																									B													A	A	A	A	A	A	A	A
Reset 0x00000000	0 0																																												
ID	R/W	Field	Value ID	Value	Description																																								
A	RW	CHIDX		[0..255]	DPPI channel that task START will subscribe to																																								
B	RW	EN	Disabled	0	Disable subscription																																								
			Enabled	1	Enable subscription																																								

6.7.10.4 SUBSCRIBE_STOP

Address offset: 0x084

Subscribe configuration for task **STOP**

Bit number	31	30	29	28	27	26	25	24	23	22	21	20	19	18	17	16	15	14	13	12	11	10	9	8	7	6	5	4	3	2	1	0													
ID																									B													A	A	A	A	A	A	A	A
Reset 0x00000000	0 0																																												
ID	R/W	Field	Value ID	Value	Description																																								
A	RW	CHIDX		[0..255]	DPPI channel that task STOP will subscribe to																																								
B	RW	EN	Disabled	0	Disable subscription																																								
			Enabled	1	Enable subscription																																								

6.7.10.5 EVENTS_RXPTRUPD

Address offset: 0x104

The RXD.PTR register has been copied to internal double-buffers. When the I2S module is started and RX is enabled, this event will be generated for every RXTXD.MAXCNT words that are received on the SDIN pin.

Bit number	31	30	29	28	27	26	25	24	23	22	21	20	19	18	17	16	15	14	13	12	11	10	9	8	7	6	5	4	3	2	1	0
ID																																A
Reset 0x00000000	0 0																															
ID	R/W	Field	Value ID	Value	Description																											
A	RW	EVENTS_RXPTRUPD			The RXD.PTR register has been copied to internal double-buffers. When the I2S module is started and RX is enabled, this event will be generated for every RXTXD.MAXCNT words that are received on the SDIN pin.																											
			NotGenerated	0	Event not generated																											
			Generated	1	Event generated																											

6.7.10.6 EVENTS_STOPPED

Address offset: 0x108

I2S transfer stopped.

Bit number	31 30 29 28 27 26 25 24 23 22 21 20 19 18 17 16 15 14 13 12 11 10 9 8 7 6 5 4 3 2 1 0																														
ID	A																														
Reset 0x00000000	0 0																														
ID	R/W	Field	Value ID	Value	Description																										
A	RW	EVENTS_STOPPED			I2S transfer stopped.																										
			NotGenerated	0	Event not generated																										
			Generated	1	Event generated																										

6.7.10.7 EVENTS_TXPTRUPD

Address offset: 0x114

The TD_X.PTR register has been copied to internal double-buffers. When the I2S module is started and TX is enabled, this event will be generated for every RXTD.MAXCNT words that are sent on the SDO_{UT} pin.

Bit number	31 30 29 28 27 26 25 24 23 22 21 20 19 18 17 16 15 14 13 12 11 10 9 8 7 6 5 4 3 2 1 0																														
ID	A																														
Reset 0x00000000	0 0																														
ID	R/W	Field	Value ID	Value	Description																										
A	RW	EVENTS_TXPTRUPD			The TD _X .PTR register has been copied to internal double-buffers. When the I2S module is started and TX is enabled, this event will be generated for every RXTD.MAXCNT words that are sent on the SDO _{UT} pin.																										
			NotGenerated	0	Event not generated																										
			Generated	1	Event generated																										

6.7.10.8 PUBLISH_RXPTRUPD

Address offset: 0x184

Publish configuration for event [RXPTRUPD](#)

Bit number	31 30 29 28 27 26 25 24 23 22 21 20 19 18 17 16 15 14 13 12 11 10 9 8 7 6 5 4 3 2 1 0																														
ID	B																														
Reset 0x00000000	0 0																														
ID	R/W	Field	Value ID	Value	Description																										
A	RW	CHIDX		[0..255]	DPPI channel that event RXPTRUPD will publish to																										
B	RW	EN																													
			Disabled	0	Disable publishing																										
			Enabled	1	Enable publishing																										

6.7.10.9 PUBLISH_STOPPED

Address offset: 0x188

Publish configuration for event [STOPPED](#)

Bit number	31 30 29 28 27 26 25 24 23 22 21 20 19 18 17 16 15 14 13 12 11 10 9 8 7 6 5 4 3 2 1 0																															
ID	B																								A A A A A A A							
Reset	0x00000000																															
Reset	0 0																															
ID	R/W	Field	Value ID	Value	Description																											
A	RW	CHIDX		[0..255]	DPPI channel that event STOPPED will publish to																											
B	RW	EN	Disabled	0	Disable publishing																											
			Enabled	1	Enable publishing																											

6.7.10.10 PUBLISH_TXPTRUPD

Address offset: 0x194

Publish configuration for event **TXPTRUPD**

Bit number	31 30 29 28 27 26 25 24 23 22 21 20 19 18 17 16 15 14 13 12 11 10 9 8 7 6 5 4 3 2 1 0																															
ID	B																								A A A A A A A							
Reset	0x00000000																															
Reset	0 0																															
ID	R/W	Field	Value ID	Value	Description																											
A	RW	CHIDX		[0..255]	DPPI channel that event TXPTRUPD will publish to																											
B	RW	EN	Disabled	0	Disable publishing																											
			Enabled	1	Enable publishing																											

6.7.10.11 INTEN

Address offset: 0x300

Enable or disable interrupt

Bit number	31 30 29 28 27 26 25 24 23 22 21 20 19 18 17 16 15 14 13 12 11 10 9 8 7 6 5 4 3 2 1 0																															
ID																									F C B							
Reset	0x00000000																															
Reset	0 0																															
ID	R/W	Field	Value ID	Value	Description																											
B	RW	RXPTRUPD			Enable or disable interrupt for event RXPTRUPD																											
			Disabled	0	Disable																											
			Enabled	1	Enable																											
C	RW	STOPPED			Enable or disable interrupt for event STOPPED																											
			Disabled	0	Disable																											
			Enabled	1	Enable																											
F	RW	TXPTRUPD			Enable or disable interrupt for event TXPTRUPD																											
			Disabled	0	Disable																											
			Enabled	1	Enable																											

6.7.10.12 INTENSET

Address offset: 0x304

Enable interrupt

Bit number	31 30 29 28 27 26 25 24 23 22 21 20 19 18 17 16 15 14 13 12 11 10 9 8 7 6 5 4 3 2 1 0																															
ID																									F C B							
Reset	0x00000000																															
Reset	0 0																															
ID	R/W	Field	Value ID	Value	Description																											
B	RW	RXPTRUPD			Write '1' to enable interrupt for event RXPTRUPD																											

Bit number	31 30 29 28 27 26 25 24 23 22 21 20 19 18 17 16 15 14 13 12 11 10 9 8 7 6 5 4 3 2 1 0																															
ID																														F	C	B
Reset 0x00000000	0 0																															
ID	R/W	Field	Value ID	Value	Description																											
			Set	1	Enable																											
			Disabled	0	Read: Disabled																											
			Enabled	1	Read: Enabled																											
C	RW	STOPPED			Write '1' to enable interrupt for event STOPPED																											
			Set	1	Enable																											
			Disabled	0	Read: Disabled																											
			Enabled	1	Read: Enabled																											
F	RW	TXPTRUPD			Write '1' to enable interrupt for event TXPTRUPD																											
			Set	1	Enable																											
			Disabled	0	Read: Disabled																											
			Enabled	1	Read: Enabled																											

6.7.10.13 INTENCLR

Address offset: 0x308

Disable interrupt

Bit number	31 30 29 28 27 26 25 24 23 22 21 20 19 18 17 16 15 14 13 12 11 10 9 8 7 6 5 4 3 2 1 0																															
ID																														F	C	B
Reset 0x00000000	0 0																															
ID	R/W	Field	Value ID	Value	Description																											
B	RW	RXPTRUPD			Write '1' to disable interrupt for event RXPTRUPD																											
			Clear	1	Disable																											
			Disabled	0	Read: Disabled																											
			Enabled	1	Read: Enabled																											
C	RW	STOPPED			Write '1' to disable interrupt for event STOPPED																											
			Clear	1	Disable																											
			Disabled	0	Read: Disabled																											
			Enabled	1	Read: Enabled																											
F	RW	TXPTRUPD			Write '1' to disable interrupt for event TXPTRUPD																											
			Clear	1	Disable																											
			Disabled	0	Read: Disabled																											
			Enabled	1	Read: Enabled																											

6.7.10.14 ENABLE

Address offset: 0x500

Enable I2S module.

Bit number	31 30 29 28 27 26 25 24 23 22 21 20 19 18 17 16 15 14 13 12 11 10 9 8 7 6 5 4 3 2 1 0																														
ID																														A	
Reset 0x00000000	0 0																														
ID	R/W	Field	Value ID	Value	Description																										
A	RW	ENABLE			Enable I2S module.																										
			Disabled	0	Disable																										
			Enabled	1	Enable																										

6.7.10.15 CONFIG.MODE

Address offset: 0x504

I2S mode.

Bit number	31	30	29	28	27	26	25	24	23	22	21	20	19	18	17	16	15	14	13	12	11	10	9	8	7	6	5	4	3	2	1	0
ID																																A
Reset 0x00000000	0 0																															
ID	R/W	Field	Value ID	Value	Description																											
A	RW	MODE			I2S mode.																											
			Master	0	Master mode. SCK and LRCK generated from internal master clock (MCK) and output on pins defined by PSEL.xxx.																											
			Slave	1	Slave mode. SCK and LRCK generated by external master and received on pins defined by PSEL.xxx																											

6.7.10.16 CONFIG.RXEN

Address offset: 0x508

Reception (RX) enable.

Bit number	31	30	29	28	27	26	25	24	23	22	21	20	19	18	17	16	15	14	13	12	11	10	9	8	7	6	5	4	3	2	1	0
ID																																A
Reset 0x00000000	0 0																															
ID	R/W	Field	Value ID	Value	Description																											
A	RW	RXEN			Reception (RX) enable.																											
			Disabled	0	Reception disabled and now data will be written to the RXD.PTR address.																											
			Enabled	1	Reception enabled.																											

6.7.10.17 CONFIG.TXEN

Address offset: 0x50C

Transmission (TX) enable.

Bit number	31	30	29	28	27	26	25	24	23	22	21	20	19	18	17	16	15	14	13	12	11	10	9	8	7	6	5	4	3	2	1	0
ID																																A
Reset 0x00000001	0 1																															
ID	R/W	Field	Value ID	Value	Description																											
A	RW	TXEN			Transmission (TX) enable.																											
			Disabled	0	Transmission disabled and now data will be read from the RXD.TXD address.																											
			Enabled	1	Transmission enabled.																											

6.7.10.18 CONFIG.MCKEN

Address offset: 0x510

Master clock generator enable.

Bit number	31	30	29	28	27	26	25	24	23	22	21	20	19	18	17	16	15	14	13	12	11	10	9	8	7	6	5	4	3	2	1	0
ID																																A
Reset 0x00000001	0																															1
ID	R/W	Field	Value ID	Value	Description																											
A	RW	MCKEN			Master clock generator enable.																											
			Disabled	0	Master clock generator disabled and PSEL.MCK not connected(available as GPIO).																											
			Enabled	1	Master clock generator running and MCK output on PSEL.MCK.																											

6.7.10.19 CONFIG.MCKFREQ

Address offset: 0x514

Master clock generator frequency.

Bit number	31	30	29	28	27	26	25	24	23	22	21	20	19	18	17	16	15	14	13	12	11	10	9	8	7	6	5	4	3	2	1	0																												
ID	A	A	A	A	A	A	A	A	A	A	A	A	A	A	A	A	A	A	A	A	A	A	A	A	A	A	A	A	A	A	A	A																												
Reset 0x20000000	0																															1	0	0	0	0	0	0	0	0	0	0	0	0	0	0	0	0	0	0	0	0	0	0	0	0	0	0	0	0
ID	R/W	Field	Value ID	Value	Description																																																							
A	RW	MCKFREQ			Master clock generator frequency.																																																							
			32MDIV8	0x20000000	32 MHz / 8 = 4.0 MHz																																																							
			32MDIV10	0x18000000	32 MHz / 10 = 3.2 MHz																																																							
			32MDIV11	0x16000000	32 MHz / 11 = 2.9090909 MHz																																																							
			32MDIV15	0x11000000	32 MHz / 15 = 2.1333333 MHz																																																							
			32MDIV16	0x10000000	32 MHz / 16 = 2.0 MHz																																																							
			32MDIV21	0x0C000000	32 MHz / 21 = 1.5238095																																																							
			32MDIV23	0x0B000000	32 MHz / 23 = 1.3913043 MHz																																																							
			32MDIV30	0x08800000	32 MHz / 30 = 1.0666667 MHz																																																							
			32MDIV31	0x08400000	32 MHz / 31 = 1.0322581 MHz																																																							
			32MDIV32	0x08000000	32 MHz / 32 = 1.0 MHz																																																							
			32MDIV42	0x06000000	32 MHz / 42 = 0.7619048 MHz																																																							
			32MDIV63	0x04100000	32 MHz / 63 = 0.5079365 MHz																																																							
			32MDIV125	0x020C0000	32 MHz / 125 = 0.256 MHz																																																							

6.7.10.20 CONFIG.RATIO

Address offset: 0x518

MCK / LRCK ratio.

Bit number	31	30	29	28	27	26	25	24	23	22	21	20	19	18	17	16	15	14	13	12	11	10	9	8	7	6	5	4	3	2	1	0																														
ID																																A	A	A	A																											
Reset 0x00000006	0																															0	0	0	0	0	0	0	0	0	0	0	0	0	0	0	0	0	0	0	0	0	0	0	0	0	0	0	0	1	1	0
ID	R/W	Field	Value ID	Value	Description																																																									
A	RW	RATIO			MCK / LRCK ratio.																																																									
			32X	0	LRCK = MCK / 32																																																									
			48X	1	LRCK = MCK / 48																																																									
			64X	2	LRCK = MCK / 64																																																									
			96X	3	LRCK = MCK / 96																																																									
			128X	4	LRCK = MCK / 128																																																									
			192X	5	LRCK = MCK / 192																																																									
			256X	6	LRCK = MCK / 256																																																									
			384X	7	LRCK = MCK / 384																																																									
			512X	8	LRCK = MCK / 512																																																									

6.7.10.21 CONFIG.SWIDTH

Address offset: 0x51C

Sample width.

Bit number	31	30	29	28	27	26	25	24	23	22	21	20	19	18	17	16	15	14	13	12	11	10	9	8	7	6	5	4	3	2	1	0
ID																											A	A				
Reset 0x00000001	0																0										0	1				
ID	R/W	Field	Value ID	Value	Description																											
A	RW	SWIDTH			Sample width.																											
			8Bit	0	8 bit.																											
			16Bit	1	16 bit.																											
			24Bit	2	24 bit.																											

6.7.10.22 CONFIG.ALIGN

Address offset: 0x520

Alignment of sample within a frame.

Bit number	31	30	29	28	27	26	25	24	23	22	21	20	19	18	17	16	15	14	13	12	11	10	9	8	7	6	5	4	3	2	1	0
ID																											A					
Reset 0x00000000	0																0										0					
ID	R/W	Field	Value ID	Value	Description																											
A	RW	ALIGN			Alignment of sample within a frame.																											
			Left	0	Left-aligned.																											
			Right	1	Right-aligned.																											

6.7.10.23 CONFIG.FORMAT

Address offset: 0x524

Frame format.

Bit number	31	30	29	28	27	26	25	24	23	22	21	20	19	18	17	16	15	14	13	12	11	10	9	8	7	6	5	4	3	2	1	0
ID																											A					
Reset 0x00000000	0																0										0					
ID	R/W	Field	Value ID	Value	Description																											
A	RW	FORMAT			Frame format.																											
			I2S	0	Original I2S format.																											
			Aligned	1	Alternate (left- or right-aligned) format.																											

6.7.10.24 CONFIG.CHANNELS

Address offset: 0x528

Enable channels.

Bit number	31	30	29	28	27	26	25	24	23	22	21	20	19	18	17	16	15	14	13	12	11	10	9	8	7	6	5	4	3	2	1	0																											
ID																															A	A																											
Reset	0x00000000																														0	0	0	0	0	0	0	0	0	0	0	0	0	0	0	0	0	0	0	0	0	0	0	0	0	0	0	0	0
ID	R/W	Field	Value ID	Value	Description																																																						
A	RW	CHANNELS			Enable channels.																																																						
			Stereo	0	Stereo.																																																						
			Left	1	Left only.																																																						
			Right	2	Right only.																																																						

6.7.10.25 RXD.PTR

Address offset: 0x538

Receive buffer RAM start address.

Bit number	31	30	29	28	27	26	25	24	23	22	21	20	19	18	17	16	15	14	13	12	11	10	9	8	7	6	5	4	3	2	1	0																										
ID	A	A	A	A	A	A	A	A	A	A	A	A	A	A	A	A	A	A	A	A	A	A	A	A	A	A	A	A	A	A	A																											
Reset	0x00000000																														0	0	0	0	0	0	0	0	0	0	0	0	0	0	0	0	0	0	0	0	0	0	0	0	0	0	0	0
ID	R/W	Field	Value ID	Value	Description																																																					
A	RW	PTR			Receive buffer Data RAM start address. When receiving, words containing samples will be written to this address. This address is a word aligned Data RAM address.																																																					

6.7.10.26 TXD.PTR

Address offset: 0x540

Transmit buffer RAM start address.

Bit number	31	30	29	28	27	26	25	24	23	22	21	20	19	18	17	16	15	14	13	12	11	10	9	8	7	6	5	4	3	2	1	0																											
ID	A	A	A	A	A	A	A	A	A	A	A	A	A	A	A	A	A	A	A	A	A	A	A	A	A	A	A	A	A	A	A																												
Reset	0x00000000																														0	0	0	0	0	0	0	0	0	0	0	0	0	0	0	0	0	0	0	0	0	0	0	0	0	0	0	0	0
ID	R/W	Field	Value ID	Value	Description																																																						
A	RW	PTR			Transmit buffer Data RAM start address. When transmitting, words containing samples will be fetched from this address. This address is a word aligned Data RAM address.																																																						

6.7.10.27 RXTXD.MAXCNT

Address offset: 0x550

Size of RXD and TXD buffers.

Bit number	31	30	29	28	27	26	25	24	23	22	21	20	19	18	17	16	15	14	13	12	11	10	9	8	7	6	5	4	3	2	1	0																											
ID																									A	A	A	A	A	A	A	A	A	A	A	A	A	A	A	A	A	A	A	A	A														
Reset	0x00000000																														0	0	0	0	0	0	0	0	0	0	0	0	0	0	0	0	0	0	0	0	0	0	0	0	0	0	0	0	0
ID	R/W	Field	Value ID	Value	Description																																																						
A	RW	MAXCNT			Size of RXD and TXD buffers in number of 32 bit words.																																																						

6.7.10.28 PSEL.MCK

Address offset: 0x560

Pin select for MCK signal.

Bit number	31	30	29	28	27	26	25	24	23	22	21	20	19	18	17	16	15	14	13	12	11	10	9	8	7	6	5	4	3	2	1	0
ID	B																								A				A	A	A	A
Reset 0xFFFFFFFF	1	1	1	1	1	1	1	1	1	1	1	1	1	1	1	1	1	1	1	1	1	1	1	1	1	1	1	1	1	1	1	
ID	R/W	Field	Value ID	Value	Description																											
A	RW	PIN		[0..31]	Pin number																											
B	RW	CONNECT			Connection																											
			Disconnected	1	Disconnect																											
			Connected	0	Connect																											

6.7.10.29 PSEL.SCK

Address offset: 0x564

Pin select for SCK signal.

Bit number	31	30	29	28	27	26	25	24	23	22	21	20	19	18	17	16	15	14	13	12	11	10	9	8	7	6	5	4	3	2	1	0
ID	B																								A				A	A	A	A
Reset 0xFFFFFFFF	1	1	1	1	1	1	1	1	1	1	1	1	1	1	1	1	1	1	1	1	1	1	1	1	1	1	1	1	1	1	1	
ID	R/W	Field	Value ID	Value	Description																											
A	RW	PIN		[0..31]	Pin number																											
B	RW	CONNECT			Connection																											
			Disconnected	1	Disconnect																											
			Connected	0	Connect																											

6.7.10.30 PSEL.LRCK

Address offset: 0x568

Pin select for LRCK signal.

Bit number	31	30	29	28	27	26	25	24	23	22	21	20	19	18	17	16	15	14	13	12	11	10	9	8	7	6	5	4	3	2	1	0
ID	B																								A				A	A	A	A
Reset 0xFFFFFFFF	1	1	1	1	1	1	1	1	1	1	1	1	1	1	1	1	1	1	1	1	1	1	1	1	1	1	1	1	1	1	1	
ID	R/W	Field	Value ID	Value	Description																											
A	RW	PIN		[0..31]	Pin number																											
B	RW	CONNECT			Connection																											
			Disconnected	1	Disconnect																											
			Connected	0	Connect																											

6.7.10.31 PSEL.SDIN

Address offset: 0x56C

Pin select for SDIN signal.

Bit number	31	30	29	28	27	26	25	24	23	22	21	20	19	18	17	16	15	14	13	12	11	10	9	8	7	6	5	4	3	2	1	0
ID	B																								A				A	A	A	A
Reset 0xFFFFFFFF	1	1	1	1	1	1	1	1	1	1	1	1	1	1	1	1	1	1	1	1	1	1	1	1	1	1	1	1	1	1	1	
ID	R/W	Field	Value ID	Value	Description																											
A	RW	PIN		[0..31]	Pin number																											
B	RW	CONNECT			Connection																											
			Disconnected	1	Disconnect																											
			Connected	0	Connect																											

6.7.10.32 PSEL.SDOUT

Address offset: 0x570

Pin select for SDOUT signal.

Bit number	31	30	29	28	27	26	25	24	23	22	21	20	19	18	17	16	15	14	13	12	11	10	9	8	7	6	5	4	3	2	1	0
ID	B																A A A A A															
Reset 0xFFFFFFFF	1 1																															
ID	R/W	Field	Value ID	Value	Description																											
A	RW	PIN		[0..31]	Pin number																											
B	RW	CONNECT			Connection																											
			Disconnected	1	Disconnect																											
			Connected	0	Connect																											

6.7.11 Electrical specification

6.7.11.1 I2S timing specification

Symbol	Description	Min.	Typ.	Max.	Units
t_{S_SDIN}	SDIN setup time before SCK rising	20			ns
t_{H_SDIN}	SDIN hold time after SCK rising	15			ns
t_{S_SDOUT}	SCK falling edge to SDOUT valid	40			ns
t_{H_SDOUT}	SDOUT hold time after SCK falling	6			ns
t_{SCK_LRCK}	SCLK falling to LRCK edge	-5	0	5	ns
f_{MCK}	MCK frequency			4000	kHz
f_{LRCK}	LRCK frequency			48	kHz
f_{SCK}	SCK frequency			2000	kHz
DC _{CK}	Clock duty cycle (MCK, LRCK, SCK)	45		55	%

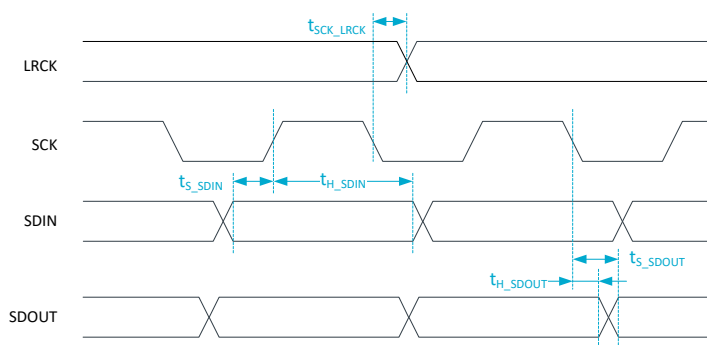

Figure 39: I2S timing diagram

6.8 KMU — Key management unit

The key management unit (KMU) enforces access policies to a subset region of user information configuration register (UICR). This subset region is used for storing cryptographic key values inside the key slots, which the CPU has no access to.

In total there are 128 key slots available, where each key slot can store one 128-bit key value together with an access policy and a destination address for the key value. Multiple key slots can be combined in order to support key sizes larger than 128 bits. The access policy of a key slot governs if and how a key value can

be used, while the destination address determines where in the memory map the KMU pushes the key value upon a request from the CPU.

Key slots can be configured to be pushed directly into write-only key registers in cryptographic accelerators, like e.g. CryptoCell, without exposing the key value itself to the CPU. This enables the CPU to use the key values stored inside the key slots for cryptographic operations without being exposed to the key value.

Access to the KMU, and the key slots in the UICR, is only allowed from secure mode.

6.8.1 Functional view

From a functional view the UICR is divided into two different regions, one-time programmable (OTP) memory and key storage.

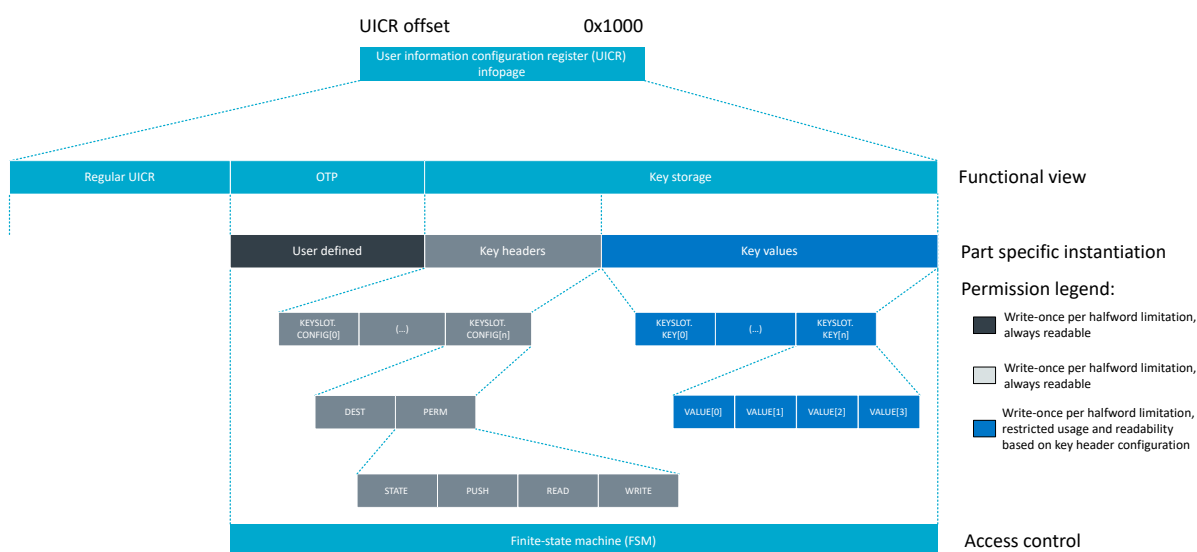

Figure 40: Memory map overview

OTP

One-time programmable (OTP) memory is typically used for holding values that are written once, and then never to be changed again throughout the product lifetime. The OTP region of UICR is emulated by placing a write-once per halfword limitation on registers defined here.

Key storage

The key storage region contains multiple key slots, where each slot consists of a key header and an associated key value. The key value is limited to 128 bits. Any key size greater than 128 bits must be divided and distributed over multiple key slot instances.

Key headers are allocated an address range of 0x400 in the UICR memory map, allowing a total of 128 keys to be addressable inside the key storage region.

Note: The use of the key storage region in UICR should be limited to keys with a certain life span, and not per-session derived keys where the CPU is involved in the key exchange.

6.8.2 Access control

Access control to the underlying UICR infopage in flash is enforced by a hardware finite-state machine (FSM). The FSM can allow or block transactions, depending both on the security of the transaction (secure or non-secure) and on the type of register being written and/or read.

Access type	Key headers	Key values
Read	Allowed	Restricted
Write	Restricted	Restricted

Table 23: Access control

Any restricted access requires an explicit key slot selection through the KMU register interface. Any illegal access to restricted key slot registers will be blocked and word `0xDEADDEAD` will be returned on the AHB.

The OTP region has individual access control behavior, while access control to the key storage region is configured on a per key slot basis. The KMU FSM operates on only one key slot instance at a time, and the permissions and the usage restriction for a key value associated with a key slot can be configured individually.

Note: Even if the KMU can be configured as non-secure, all non-secure transactions will be blocked.

6.8.3 Protecting the UICR content

The UICR content can be protected against device-internal NVMC.ERASEALL requests, in addition to device-external ERASEALL requests, through the CTRL-AP interface. This feature is useful if the firmware designers want to prevent the OTP region from being erased.

Since enabling this step will permanently disable erase for the UICR, the procedure requires an implementation defined 32-bit word to be written into the UICR's ERASEPROTECT register.

In case of a field return handling, it is still possible to erase the UICR even if the ERASEPROTECT is set. If this functionality is desired, the secure boot code must implement a secure communication channel over the CTRL-AP mailbox interface. Upon successful authentication of the external party, the secure boot code can temporarily re-enable the CTRL-AP ERASEALL functionality.

6.8.4 Usage

This section describes the specific KMU and UICR behavior in more detail, to help the reader get a better overview of KMU's features and the intended usage.

6.8.4.1 OTP

The OTP region of the UICR contains a user-defined static configuration of the device. The KMU emulates the OTP functionality by placing a write-once per halfword limitation of registers defined in this region, i.e. only halfwords containing all '1's can be written.

An OTP write transaction must consist of a full 32-bit word. Both halfwords can either be written simultaneously or one at a time. The KMU FSM will block any write to a halfword in the OTP region, if the initial value of this halfword is not `0xFFFF`. When writing halfwords one at a time, the non-active halfword must be masked as `0xFFFF`, otherwise the request will be blocked. For example, writing `0x1234XXXX` to an OTP destination address which already contains the value `0xFFFFAABB`, must be configured as `0x1234FFFF`. The OTP destination address will contain the value `0x1234AABB` after both write transactions have been processed.

The KMU will also only allow secure AHB write transactions into the OTP region of the UICR. Any AHB write transaction to this region that does not satisfy the above requirements will be ignored, and the `STATUS.BLOCKED` register will be set to '1'.

6.8.4.2 Key storage

The key storage region of the UICR can contain multiple keys of different type, including symmetrical keys, hashes, public/private key pairs and other device secrets. One of the key features of the KMU, is that these

device secrets can be installed and made available for use in cryptographic operations without revealing the actual secret values.

Keys in this region will typically have a certain life span. The region is not designed to be used for per-session derived keys where the non-secure side (i.e. application) is participating in the key exchange.

All key storage is done through the concept of multiple key slots, where each key slot instance consists of one key header and an associated key value. Each key header supports the configuration of usage permissions and an optional secure destination address.

The key header secure destination address option enables the KMU to push the associated key value over a dedicated secure APB to a pre-configured secure location within the memory map. Such locations typically include a write-only key register of the hardware cryptographic accelerator, allowing the KMU to distribute keys within the system without compromising the key values.

One key slot instance can store a key value of maximum 128 bits. If a key size exceeds this limit, the key value itself must be split over multiple key slot instances.

The following usage and read permissions scheme is applicable for each key slot:

State	Push	Read	Write	Description
Active (1)	Enabled (1)	Enabled (1)	Enabled (1)	Default flash erase value. Key slot cannot be pushed, write is enabled.
Active (1)	Enabled (1)	Enabled (1)	Disabled (0)	Key slot is active, push is enabled. Key slot VALUE registers can be read, but write is disabled.
Active (1)	Enabled (1)	Disabled (0)	Disabled (0)	Key slot is active, push is enabled. Read and write to key slot VALUE registers are disabled.
Active (1)	Disabled (0)	Enabled (1)	Disabled (0)	Key slot is active, push is disabled. Key slot VALUE registers can be read, but write is disabled.
Revoked (0)	-	-	-	Key slot is revoked. Cannot be read or pushed over secure APB regardless of the permission settings.

Table 24: Valid key slot permission schemes

6.8.4.2.1 Selecting a key slot

The KMU FSM is designed to process only one key slot at a time, effectively operating as a memory protection unit for the key storage region. Whenever a key slot is selected, the KMU will allow access to writing, reading, and/or pushing the associated key value according to the selected slot configuration.

A key slot must be selected prior to use, by writing the key slot ID into the KMU SELECTKEYSLOT register. Because the reset value of this register is 0x00000000, there is no key slot associated with ID=0 and no slot is selected by default. All key slots are addressed using IDs from 1 to 128.

SELECTED status is set when a key slot is selected, and a read or write access to that keyslot occurs.

BLOCKED status is set when any illegal access to key slot registers is detected.

When the use of the particular key slot is stopped, the key slot selection in SELECTKEYSLOT must be set back to '0'.

By default, all KMU key slots will consist of a 128-bit key value of '1's, where the key headers have no secure destination address, or any usage and read restrictions.

6.8.4.2.2 Writing to a key slot

Writing a key slot into UICR is a five-step process.

1. Select which key slot the KMU shall operate on by writing the desired key slot ID into KMU->SELECTKEYSLOT. The selected key slot must be empty in order to add a new entry to UICR.
2. If the key value shall be pushable over secure APB, the destination address of the recipient must be configured in register KEYSLOT.CONFIG[ID-1].DEST.

3. Write the 128-bit key value into KEYSLOT.KEY[ID-1].VALUE[0-3].
4. Write the desired key slot permissions into KEYSLOT.CONFIG[ID-1].PERM, including any applicable usage restrictions.
5. Select key slot 0.

In case the total key size is greater than 128 bits, the key value itself must be split into 128-bit segments and written to multiple key slot instances. Steps 1 through 5 above must be repeated for the entire key size.

Note: If a key slot is configured as readable, and KEYSLOT.CONFIG[ID-1].DEST is not to be used, it is recommended to disable the push bit in KEYSLOT.CONFIG[ID-1].PERM when configuring key slot permissions.

Note: A key value distributed over multiple key slots should use the same key slot configuration in its key headers, but the secure destination address for each key slot instance must be incremented by 4 words (128 bits) for each key slot instance spanned.

Note: Write to flash must be enabled in NVMC->CONFIG prior to writing keys to flash, and subsequently disabled once writing is complete.

Steps 1 through 5 above will be blocked if any of the following violations are detected:

- No key slot selected
- Non-empty key slot selected
- NVM destination address not empty
- AHB write to KEYSLOT.KEY[ID-1].VALUE[0-3] registers not belonging to selected key slot

6.8.4.2.3 Reading a key value

Key slots that are configured as readable can have their key value read directly from the UICR memory map by the CPU.

Readable keys are typically used during the secure boot sequence, where the CPU is involved in falsifying or verifying the integrity of the system. Since the CPU is involved in this decision process, it makes little sense not to trust the CPU having access to the actual key value but ultimately trust the decision of the integrity check. Another use-case for readable keys is if the key type in question does not have a HW peripheral in the platform that is able to accept such keys over secure APB.

Reading a key value from the UICR is a three-step process:

1. Select the key slot which the KMU shall operate on by writing the desired key slot ID into KMU->SELECTKEYSLOT.
2. If STATE and READ permission requirements are fulfilled as defined in KEYSLOT.CONFIG[ID-1].PERM, the key value can be read from region KEYSLOT.KEY[ID-1].VALUE[0-3] for selected key slot.
3. Select key slot 0.

Step 2 will be blocked and word 0xDEADDEAD will be returned on AHB if any of the following violations are detected:

- No key slot selected
- Key slot not configured as readable
- Key slot is revoked
- AHB read to KEYSLOT.KEY[ID-1].VALUE[0-3] registers not belonging to selected key slot

6.8.4.2.4 Push over secure APB

Key slots that are configured as non-readable cannot be read by the CPU regardless of the mode the system is in and must be pushed over secure APB in order to use the key value for cryptographic operations.

The secure APB destination address is set in the key slot configuration DEST register. Such destination addresses are typically write-only key registers in a hardware cryptographic accelerators memory map. The secure APB allows key slots to be utilized by the software side, without exposing the key value itself.

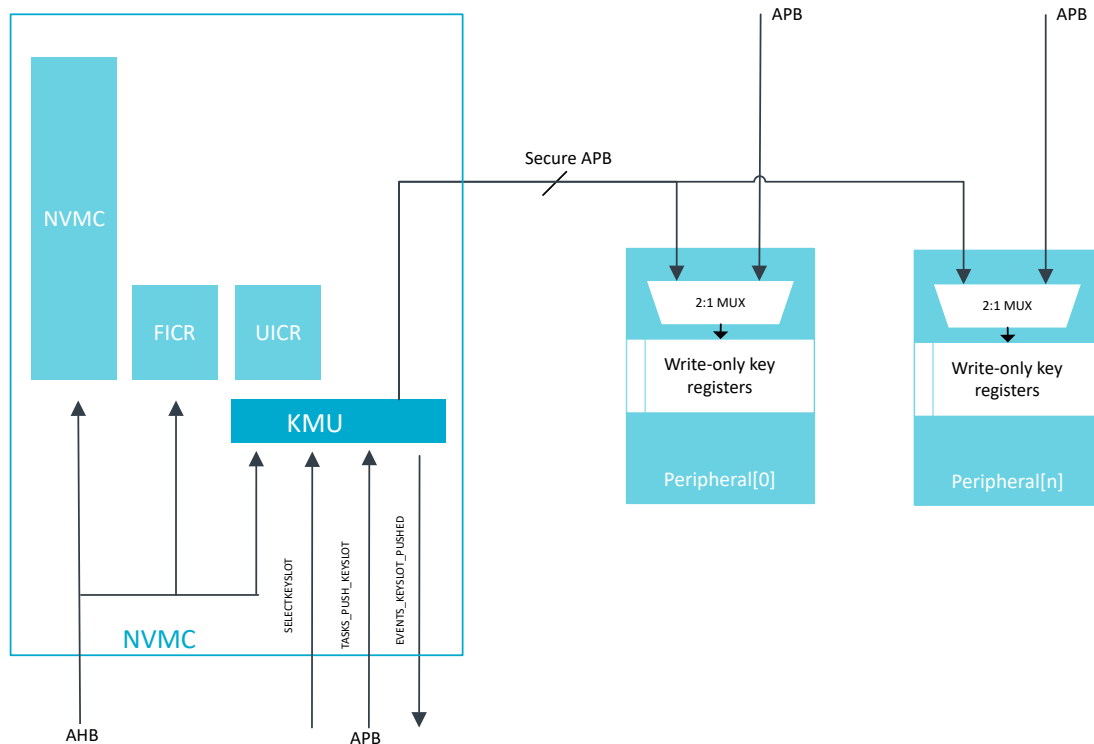

Figure 41: Tasks and events pattern for key slots

Pushing a key slot over secure APB is a four-step process:

1. Select the key slot on which the KMU shall operate by writing the desired key slot ID into `KMU->SELECTKEYSLOT`.
2. Start `TASKS_PUSH_KEYSLLOT` to initiate a secure APB transaction, writing the 128-bit key value associated with the selected key slot into address defined in `KEYSLOT.CONFIG[ID-1].DEST`.
3. After completing the secure APB transaction, the 128-bit key value is ready for use by the peripheral and `EVENTS_KEYSLLOT_PUSHED` is triggered.
4. Select key slot 0.

Note: If a key value is distributed over multiple key slots due to its key size, exceeding the maximum 128-bit key value limitation, then each distributed key slot must be pushed individually in order to transfer the entire key value over secure APB.

Step 3 will trigger other events than `EVENTS_KEYSLLOT_PUSHED` if the following violations are detected:

- `EVENTS_KEYSLLOT_ERROR`:
 - If no key slot is selected
 - If a key slot has no destination address configured
 - If when pushing a key slot, flash, or peripheral returns an error
 - If pushing a key slot when push permissions are disabled

- If attempting to push a key slot with default permissions
- EVENTS_KEYSLLOT_REVOKED if a key slot is marked as revoked in its key header configuration

6.8.4.2.5 Revoking the key slots

All key slots within the key storage area can be marked as revoked.

To revoke any key slots, write to the STATE field in the KEYSLOT.CONFIG[ID-1].PERM register. The following rules apply to keys that have been revoked:

1. Key slots that have the PUSH field enabled in PERM register can no longer be pushed. If a revoked key slot is selected and task TASKS_PUSH_KEYSLLOT is started, the event EVENTS_KEYSLLOT_REVOKED is triggered.
2. Key slots that have the READ field enabled in PERM register can no longer be read. Any read operation to a revoked key value will return word 0xDEADDEAD.
3. Previously pushed key values stored in a peripheral write-only key register are not affected by key revocation. If secure code wants to enforce that a revoked key is no longer usable by a peripheral for cryptographic operations, the secure code should disable or reset the peripheral in question.

6.8.4.3 STATUS register

The KMU uses a STATUS register to indicate its status of operation. The SELECTED bit will be asserted whenever the currently selected key slot is successfully read from or written to.

All read or write operations to other key slots than what is currently selected in KMU->SELECTKEYSLOT will assert the BLOCKED bit. The BLOCKED bit will also be asserted if the KMU fails to select a key slot, or if a request has been blocked due to an access violation. Normal operation using the KMU should never trigger the BLOCKED bit. If this bit is triggered during the development phase, it indicates that the code is using the KMU incorrectly.

The STATUS register is reset every time register SELECTKEYSLOT is written.

6.8.5 Registers

Instances

Instance	Base address	TrustZone			Split access	Description
		Map	Att	DMA		
KMU : S	0x50039000	HF	NS	NA	Yes	Key management unit
KMU : NS	0x40039000					

Register overview

Register	Offset	TZ	Description
TASKS_PUSH_KEYSLLOT	0x0000		Push a key slot over secure APB
EVENTS_KEYSLLOT_PUSHED	0x100		Key slot successfully pushed over secure APB
EVENTS_KEYSLLOT_REVOKED	0x104		Key slot has been revoked and cannot be tasked for selection
EVENTS_KEYSLLOT_ERROR	0x108		No key slot selected, no destination address defined, or error during push operation
INTEN	0x300		Enable or disable interrupt
INTENSET	0x304		Enable interrupt
INTENCLR	0x308		Disable interrupt
INTPEND	0x30C		Pending interrupts
STATUS	0x40C		Status bits for KMU operation
SELECTKEYSLOT	0x500		Select key slot to be read over AHB or pushed over secure APB when TASKS_PUSH_KEYSLLOT is started

6.8.5.1 TASKS_PUSH_KEYSLLOT

Address offset: 0x0000

Push a key slot over secure APB

Bit number	31 30 29 28 27 26 25 24 23 22 21 20 19 18 17 16 15 14 13 12 11 10 9 8 7 6 5 4 3 2 1 0																														
ID	A																														
Reset 0x00000000	0 0																														
ID	R/W	Field	Value ID	Value	Description																										
A	W	TASKS_PUSH_KEYSLLOT			Push a key slot over secure APB																										
			Trigger	1	Trigger task																										

6.8.5.2 EVENTS_KEYSLLOT_PUSHED

Address offset: 0x100

Key slot successfully pushed over secure APB

Bit number	31 30 29 28 27 26 25 24 23 22 21 20 19 18 17 16 15 14 13 12 11 10 9 8 7 6 5 4 3 2 1 0																														
ID	A																														
Reset 0x00000000	0 0																														
ID	R/W	Field	Value ID	Value	Description																										
A	RW	EVENTS_KEYSLLOT_PUSHED			Key slot successfully pushed over secure APB																										
			NotGenerated	0	Event not generated																										
			Generated	1	Event generated																										

6.8.5.3 EVENTS_KEYSLLOT_REVOKED

Address offset: 0x104

Key slot has been revoked and cannot be tasked for selection

Bit number	31 30 29 28 27 26 25 24 23 22 21 20 19 18 17 16 15 14 13 12 11 10 9 8 7 6 5 4 3 2 1 0																														
ID	A																														
Reset 0x00000000	0 0																														
ID	R/W	Field	Value ID	Value	Description																										
A	RW	EVENTS_KEYSLLOT_REVOKED			Key slot has been revoked and cannot be tasked for selection																										
			NotGenerated	0	Event not generated																										
			Generated	1	Event generated																										

6.8.5.4 EVENTS_KEYSLLOT_ERROR

Address offset: 0x108

No key slot selected, no destination address defined, or error during push operation

Bit number	31 30 29 28 27 26 25 24 23 22 21 20 19 18 17 16 15 14 13 12 11 10 9 8 7 6 5 4 3 2 1 0																														
ID	A																														
Reset 0x00000000	0 0																														
ID	R/W	Field	Value ID	Value	Description																										
A	RW	EVENTS_KEYSLLOT_ERROR			No key slot selected, no destination address defined, or error during push operation																										
			NotGenerated	0	Event not generated																										
			Generated	1	Event generated																										

6.8.5.5 INTEN

Address offset: 0x300

Enable or disable interrupt

Bit number	31 30 29 28 27 26 25 24 23 22 21 20 19 18 17 16 15 14 13 12 11 10 9 8 7 6 5 4 3 2 1 0																																
ID																															C	B	A
Reset 0x00000000	0 0																																
ID	R/W	Field	Value ID	Value	Description																												
A	RW	KEYSLOT_PUSHED			Enable or disable interrupt for event KEYSLOT_PUSHED																												
			Disabled	0	Disable																												
			Enabled	1	Enable																												
B	RW	KEYSLOT_REVOKED			Enable or disable interrupt for event KEYSLOT_REVOKED																												
			Disabled	0	Disable																												
			Enabled	1	Enable																												
C	RW	KEYSLOT_ERROR			Enable or disable interrupt for event KEYSLOT_ERROR																												
			Disabled	0	Disable																												
			Enabled	1	Enable																												

6.8.5.6 INTENSET

Address offset: 0x304

Enable interrupt

Bit number	31 30 29 28 27 26 25 24 23 22 21 20 19 18 17 16 15 14 13 12 11 10 9 8 7 6 5 4 3 2 1 0																																
ID																															C	B	A
Reset 0x00000000	0 0																																
ID	R/W	Field	Value ID	Value	Description																												
A	RW	KEYSLOT_PUSHED			Write '1' to enable interrupt for event KEYSLOT_PUSHED																												
			Set	1	Enable																												
			Disabled	0	Read: Disabled																												
			Enabled	1	Read: Enabled																												
B	RW	KEYSLOT_REVOKED			Write '1' to enable interrupt for event KEYSLOT_REVOKED																												
			Set	1	Enable																												
			Disabled	0	Read: Disabled																												
			Enabled	1	Read: Enabled																												
C	RW	KEYSLOT_ERROR			Write '1' to enable interrupt for event KEYSLOT_ERROR																												
			Set	1	Enable																												
			Disabled	0	Read: Disabled																												
			Enabled	1	Read: Enabled																												

6.8.5.7 INTENCLR

Address offset: 0x308

Disable interrupt

Bit number	31 30 29 28 27 26 25 24 23 22 21 20 19 18 17 16 15 14 13 12 11 10 9 8 7 6 5 4 3 2 1 0																																
ID																															C	B	A
Reset 0x00000000	0 0																																
ID	R/W	Field	Value ID	Value	Description																												
A	RW	KEYSLOT_PUSHED	Clear	1	Write '1' to disable interrupt for event KEYSLOT_PUSHED																												
					Disable																												

Bit number		31 30 29 28 27 26 25 24 23 22 21 20 19 18 17 16 15 14 13 12 11 10 9 8 7 6 5 4 3 2 1 0																															
ID																															C	B	A
Reset 0x00000000		0 0																															
ID	R/W	Field	Value ID	Value	Description																												
			Disabled	0	Read: Disabled																												
			Enabled	1	Read: Enabled																												
B	RW	KEYSLOT_REVOKED			Write '1' to disable interrupt for event KEYSLOT_REVOKED																												
			Clear	1	Disable																												
			Disabled	0	Read: Disabled																												
			Enabled	1	Read: Enabled																												
C	RW	KEYSLOT_ERROR			Write '1' to disable interrupt for event KEYSLOT_ERROR																												
			Clear	1	Disable																												
			Disabled	0	Read: Disabled																												
			Enabled	1	Read: Enabled																												

6.8.5.8 INTPEND

Address offset: 0x30C

Pending interrupts

Bit number		31 30 29 28 27 26 25 24 23 22 21 20 19 18 17 16 15 14 13 12 11 10 9 8 7 6 5 4 3 2 1 0																															
ID																															C	B	A
Reset 0x00000000		0 0																															
ID	R/W	Field	Value ID	Value	Description																												
A	R	KEYSLOT_PUSHED			Read pending status of interrupt for event KEYSLOT_PUSHED																												
			NotPending	0	Read: Not pending																												
			Pending	1	Read: Pending																												
B	R	KEYSLOT_REVOKED			Read pending status of interrupt for event KEYSLOT_REVOKED																												
			NotPending	0	Read: Not pending																												
			Pending	1	Read: Pending																												
C	R	KEYSLOT_ERROR			Read pending status of interrupt for event KEYSLOT_ERROR																												
			NotPending	0	Read: Not pending																												
			Pending	1	Read: Pending																												

6.8.5.9 STATUS

Address offset: 0x40C

Status bits for KMU operation

This register is reset and re-written by the KMU whenever SELECTKEYSLOT is written

Bit number		31 30 29 28 27 26 25 24 23 22 21 20 19 18 17 16 15 14 13 12 11 10 9 8 7 6 5 4 3 2 1 0																														
ID																															B	A
Reset 0x00000000		0 0																														
ID	R/W	Field	Value ID	Value	Description																											
A	R	SELECTED			Key slot ID successfully selected by the KMU																											
			Disabled	0	No key slot ID selected by KMU																											
			Enabled	1	Key slot ID successfully selected by KMU																											
B	R	BLOCKED			Violation status																											
			Disabled	0	No access violation detected																											
			Enabled	1	Access violation detected and blocked																											

6.8.5.10 SELECTKEYSLOT

Address offset: 0x500

Select key slot to be read over AHB or pushed over secure APB when TASKS_PUSH_KEYSLOT is started

Bit number	31	30	29	28	27	26	25	24	23	22	21	20	19	18	17	16	15	14	13	12	11	10	9	8	7	6	5	4	3	2	1	0
ID	A A A A A A A A																															
Reset 0x00000000	0 0																															
ID	R/W	Field	Value ID	Value	Description																											
A	RW	ID			Select key slot ID to be read over AHB, or pushed over secure APB, when TASKS_PUSH_KEYSLOT is started.																											
NOTE: ID=0 is not a valid key slot ID. The 0 ID should be used when the KMU is idle or not in use.																																
NOTE: Index N in UICR->KEYSLOT.KEY[N] and UICR->KEYSLOT.CONFIG[N] corresponds to KMU key slot ID=N+1.																																

6.9 PDM — Pulse density modulation interface

The pulse density modulation (PDM) module enables input of pulse density modulated signals from external audio frontends, for example, digital microphones. The PDM module generates the PDM clock and supports single-channel or dual-channel (left and right) data input. Data is transferred directly to RAM buffers using EasyDMA.

Listed here are the main features for PDM:

- Up to two PDM microphones configured as a left/right pair using the same data input
- 16 kHz output sample rate, 16-bit samples
- EasyDMA support for sample buffering
- HW decimation filters
- Selectable ratio of 64 or 80 between PDM_CLK and output sample rate

The PDM module illustrated below is interfacing up to two digital microphones with the PDM interface. EasyDMA is implemented to relieve the real-time requirements associated with controlling of the PDM slave from a low priority CPU execution context. It also includes all the necessary digital filter elements to produce pulse code modulation (PCM) samples. The PDM module allows continuous audio streaming.

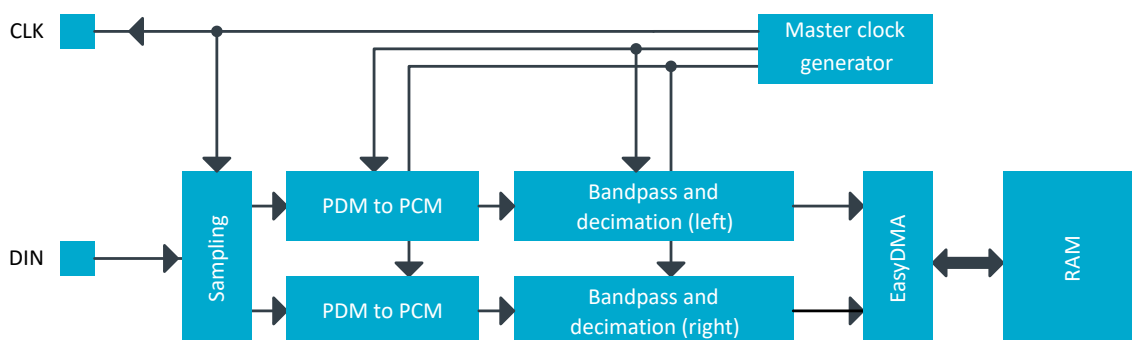

Figure 42: PDM module

6.9.1 Master clock generator

The master clock generator's PDMCLKCTRL register allows adjusting the PDM clock's frequency.

The master clock generator does not add any jitter to the HFCLK source chosen. It is recommended (but not mandatory) to use the Xtal as HFCLK source.

6.9.2 Module operation

By default, bits from the left PDM microphone are sampled on PDM_CLK falling edge, and bits for the right are sampled on the rising edge of PDM_CLK, resulting in two bitstreams. Each bitstream is fed into a digital filter which converts the PDM stream into 16-bit PCM samples, then filters and down-samples them to reach the appropriate sample rate.

The EDGE field in the MODE register allows swapping left and right, so that left will be sampled on rising edge, and right on falling.

The PDM module uses EasyDMA to store the samples coming out from the filters into one buffer in RAM. Depending on the mode chosen in the OPERATION field in the MODE register, memory either contains alternating left and right 16-bit samples (Stereo), or only left 16-bit samples (Mono). To ensure continuous PDM sampling, it is up to the application to update the EasyDMA destination address pointer as the previous buffer is filled.

The continuous transfer can be started or stopped by sending the START and STOP tasks. STOP becomes effective after the current frame has finished transferring, which will generate the STOPPED event. The STOPPED event indicates that all activity in the module is finished, and that the data is available in RAM (EasyDMA has finished transferring as well). Attempting to restart before receiving the STOPPED event may result in unpredictable behavior.

6.9.3 Decimation filter

In order to convert the incoming data stream into PCM audio samples, a decimation filter is included in the PDM interface module.

The input of the filter is the two-channel PDM serial stream (with left channel on clock high, right channel on clock low). Depending on the RATIO selected, its output is 2×16 -bit PCM samples at a sample rate either 64 times or 80 times (depending on the RATIO register) lower than the PDM clock rate.

The filter stage of each channel is followed by a digital volume control, to attenuate or amplify the output samples in a range of -20 dB to +20 dB around the default (reset) setting, defined by $G_{\text{PDM,default}}$. The gain is controlled by the GAINL and GAINR registers.

As an example, if the goal is to achieve 2500 RMS output samples (16-bit) with a 1 kHz 90 dBA signal into a -26 dBFS sensitivity PDM microphone, do the following:

- Sum the PDM module's default gain ($G_{\text{PDM,default}}$) and the gain introduced by the microphone and acoustic path of his implementation (an attenuation would translate into a negative gain)
- Adjust GAINL and GAINR by the above summed amount. Assuming that only the PDM module influences the gain, GAINL and GAINR must be set to $-G_{\text{PDM,default}}$ dB to achieve the requirement.

With $G_{\text{PDM,default}}=3.2$ dB, and as GAINL and GAINR are expressed in 0.5 dB steps, the closest value to program would be 3.0 dB, which can be calculated as:

$$\text{GAINL} = \text{GAINR} = (\text{DefaultGain} - (2 * 3))$$

Remember to check that the resulting values programmed into GAINL and GAINR fall within MinGain and MaxGain.

6.9.4 EasyDMA

Samples will be written directly to RAM, and EasyDMA must be configured accordingly.

The address pointer for the EasyDMA channel is set in SAMPLE.PTR register. If the destination address set in SAMPLE.PTR is not pointing to the Data RAM region, an EasyDMA transfer may result in a HardFault or RAM corruption. See [Memory](#) on page 23 for more information about the different memory regions.

DMA supports Stereo (Left+Right 16-bit samples) and Mono (Left only) data transfer, depending on the setting in the OPERATION field in the MODE register. The samples are stored little endian.

MODE.OPERATION	Bits per sample	Result stored per RAM word	Physical RAM allocated (32-bit words)	Result boundary indexes in RAM	Note
Stereo	32 (2x16)	L+R	$\text{ceil}(\text{SAMPLE.MAXCNT}/2)$	R0=[31:16]; L0=[15:0]	Default
Mono	16	2xL	$\text{ceil}(\text{SAMPLE.MAXCNT}/2)$	L1=[31:16]; L0=[15:0]	

Table 25: DMA sample storage

The destination buffer in RAM consists of one block, the size of which is set in SAMPLE.MAXCNT register. Format is number of 16-bit samples. The physical RAM allocated is always:

```
(RAM allocation, in bytes) = SAMPLE.MAXCNT * 2;
```

(but the mapping of the samples depends on MODE.OPERATION).

If OPERATION=Stereo, RAM will contain a succession of left and right samples.

If OPERATION=Mono, RAM will contain a succession of left only samples.

For a given value of SAMPLE.MAXCNT, the buffer in RAM can contain half the stereo sampling time as compared to the mono sampling time.

The PDM acquisition can be started by the START task, after the SAMPLE.PTR and SAMPLE.MAXCNT registers have been written. When starting the module, it will take some time for the filters to start outputting valid data. Transients from the PDM microphone itself may also occur. The first few samples (typically around 50) might hence contain invalid values or transients. It is therefore advised to discard the first few samples after a PDM start.

As soon as the STARTED event is received, the firmware can write the next SAMPLE.PTR value (this register is double-buffered), to ensure continuous operation.

When the buffer in RAM is filled with samples, an END event is triggered. The firmware can start processing the data in the buffer. Meanwhile, the PDM module starts acquiring data into the new buffer pointed to by SAMPLE.PTR, and sends a new STARTED event, so that the firmware can update SAMPLE.PTR to the next buffer address.

6.9.5 Hardware example

PDM can be configured with a single microphone (mono), or with two microphones.

When a single microphone is used, connect the microphone clock to CLK, and data to DIN.

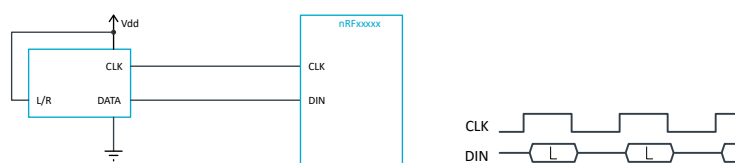

Figure 43: Example of a single PDM microphone, wired as left

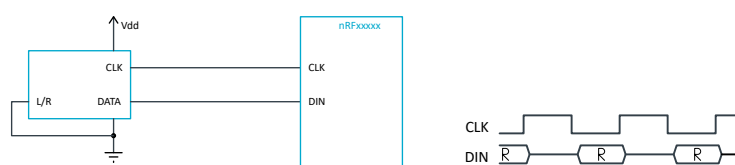

Figure 44: Example of a single PDM microphone, wired as right

Note that in a single-microphone (mono) configuration, depending on the microphone's implementation, either the left or the right channel (sampled at falling or rising CLK edge respectively) will contain reliable data.

If two microphones are used, one of them must be set as left, the other as right (L/R pin tied high or to GND on the respective microphone). It is strongly recommended to use two microphones of exactly the same brand and type so that their timings in left and right operation match.

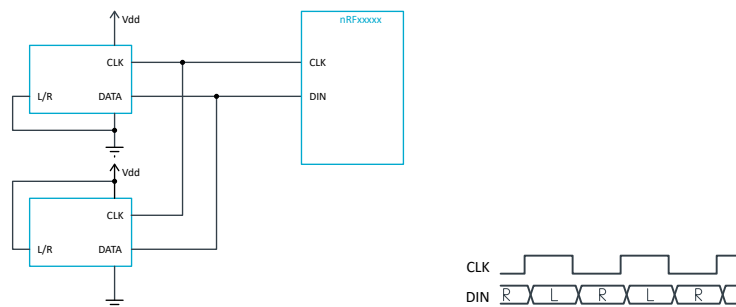

Figure 45: Example of two PDM microphones

6.9.6 Pin configuration

The CLK and DIN signals associated to the PDM module are mapped to physical pins according to the configuration specified in the PSEL.CLK and PSEL.DIN registers respectively. If the CONNECT field in any PSEL register is set to Disconnected, the associated PDM module signal will not be connected to the required physical pins and will not operate properly.

The PSEL.CLK and PSEL.DIN registers and their configurations are only used as long as the PDM module is enabled, and retained only as long as the device is in System ON mode. See [POWER — Power control](#) on page 69 for more information about power modes. When the peripheral is disabled, the pins will behave as regular GPIOs, and use the configuration in their respective OUT bit field and PIN_CNFG[n] register.

To ensure correct behavior in the PDM module, the pins used by the PDM module must be configured in the GPIO peripheral as described in [GPIO configuration before enabling peripheral](#) on page 219 before enabling the PDM module. This is to ensure that the pins used by the PDM module are driven correctly if the PDM module itself is temporarily disabled or the device temporarily enters System OFF. This configuration must be retained in the GPIO for the selected I/Os as long as the PDM module is supposed to be connected to an external PDM circuit.

Only one peripheral can be assigned to drive a particular GPIO pin at a time. Failing to do so may result in unpredictable behavior.

PDM signal	PDM pin	Direction	Output value	Comment
CLK	As specified in PSEL.CLK	Output	0	
DIN	As specified in PSEL.DIN	Input	Not applicable	

Table 26: GPIO configuration before enabling peripheral

6.9.7 Registers

Instances

Instance	Base address	TrustZone			Split access	Description
		Map	Att	DMA		
PDM : S	0x50026000	US	NS	SA	No	Pulse density modulation (digital microphone) interface
PDM : NS	0x40026000					

Register overview

Register	Offset	TZ	Description
TASKS_START	0x000		Starts continuous PDM transfer
TASKS_STOP	0x004		Stops PDM transfer
SUBSCRIBE_START	0x080		Subscribe configuration for task START
SUBSCRIBE_STOP	0x084		Subscribe configuration for task STOP
EVENTS_STARTED	0x100		PDM transfer has started
EVENTS_STOPPED	0x104		PDM transfer has finished
EVENTS_END	0x108		The PDM has written the last sample specified by <code>SAMPLE.MAXCNT</code> (or the last sample after a <code>STOP</code> task has been received) to Data RAM
PUBLISH_STARTED	0x180		Publish configuration for event STARTED
PUBLISH_STOPPED	0x184		Publish configuration for event STOPPED
PUBLISH_END	0x188		Publish configuration for event END
INTEN	0x300		Enable or disable interrupt
INTENSET	0x304		Enable interrupt
INTENCLR	0x308		Disable interrupt
ENABLE	0x500		PDM module enable register
PDMCLKCTRL	0x504		PDM clock generator control
MODE	0x508		Defines the routing of the connected PDM microphones' signals
GAINL	0x518		Left output gain adjustment
GAINR	0x51C		Right output gain adjustment
RATIO	0x520		Selects the ratio between <code>PDM_CLK</code> and output sample rate. Change <code>PDMCLKCTRL</code> accordingly.
PSEL_CLK	0x540		Pin number configuration for PDM CLK signal
PSEL_DIN	0x544		Pin number configuration for PDM DIN signal
SAMPLE_PTR	0x560		RAM address pointer to write samples to with EasyDMA
SAMPLE.MAXCNT	0x564		Number of samples to allocate memory for in EasyDMA mode

6.9.7.1 TASKS_START

Address offset: 0x000

Starts continuous PDM transfer

Bit number	31 30 29 28 27 26 25 24 23 22 21 20 19 18 17 16 15 14 13 12 11 10 9 8 7 6 5 4 3 2 1 0																														
ID	A																														
Reset 0x00000000	0 0																														
ID	R/W	Field	Value ID	Value	Description																										
A	W	TASKS_START			Starts continuous PDM transfer																										
			Trigger	1	Trigger task																										

6.9.7.2 TASKS_STOP

Address offset: 0x004

Stops PDM transfer

Bit number	31 30 29 28 27 26 25 24 23 22 21 20 19 18 17 16 15 14 13 12 11 10 9 8 7 6 5 4 3 2 1 0																														
ID	A																														
Reset 0x00000000	0 0																														
ID	R/W	Field	Value ID	Value	Description																										
A	W	TASKS_STOP			Stops PDM transfer																										
			Trigger	1	Trigger task																										

6.9.7.3 SUBSCRIBE_START

Address offset: 0x080

Subscribe configuration for task **START**

Bit number	31 30 29 28 27 26 25 24 23 22 21 20 19 18 17 16 15 14 13 12 11 10 9 8 7 6 5 4 3 2 1 0																																										
ID	B																											A				A				A				A			
Reset 0x00000000	0 0																																										
ID	R/W	Field	Value ID	Value	Description																																						
A	RW	CHIDX		[0..255]	DPPI channel that task START will subscribe to																																						
B	RW	EN	Disabled	0	Disable subscription																																						
			Enabled	1	Enable subscription																																						

6.9.7.4 SUBSCRIBE_STOP

Address offset: 0x084

Subscribe configuration for task **STOP**

Bit number	31 30 29 28 27 26 25 24 23 22 21 20 19 18 17 16 15 14 13 12 11 10 9 8 7 6 5 4 3 2 1 0																																						
ID	B																											A				A				A			
Reset 0x00000000	0 0																																						
ID	R/W	Field	Value ID	Value	Description																																		
A	RW	CHIDX		[0..255]	DPPI channel that task STOP will subscribe to																																		
B	RW	EN	Disabled	0	Disable subscription																																		
			Enabled	1	Enable subscription																																		

6.9.7.5 EVENTS_STARTED

Address offset: 0x100

PDM transfer has started

Bit number	31 30 29 28 27 26 25 24 23 22 21 20 19 18 17 16 15 14 13 12 11 10 9 8 7 6 5 4 3 2 1 0																														
ID																															A
Reset 0x00000000	0 0																														
ID	R/W	Field	Value ID	Value	Description																										
A	RW	EVENTS_STARTED			PDM transfer has started																										
			NotGenerated	0	Event not generated																										
			Generated	1	Event generated																										

6.9.7.6 EVENTS_STOPPED

Address offset: 0x104

PDM transfer has finished

Bit number	31	30	29	28	27	26	25	24	23	22	21	20	19	18	17	16	15	14	13	12	11	10	9	8	7	6	5	4	3	2	1	0	
ID	A																																
Reset	0x00000000																																
Reset	0	0	0	0	0	0	0	0	0	0	0	0	0	0	0	0	0	0	0	0	0	0	0	0	0	0	0	0	0	0	0	0	0
ID	R/W	Field	Value ID	Value	Description																												
A	RW	EVENTS_STOPPED			PDM transfer has finished																												
			NotGenerated	0	Event not generated																												
			Generated	1	Event generated																												

6.9.7.7 EVENTS_END

Address offset: 0x108

The PDM has written the last sample specified by SAMPLE.MAXCNT (or the last sample after a STOP task has been received) to Data RAM

Bit number	31	30	29	28	27	26	25	24	23	22	21	20	19	18	17	16	15	14	13	12	11	10	9	8	7	6	5	4	3	2	1	0
ID	A																															
Reset	0x00000000																															
Reset	0	0	0	0	0	0	0	0	0	0	0	0	0	0	0	0	0	0	0	0	0	0	0	0	0	0	0	0	0	0	0	0
ID	R/W	Field	Value ID	Value	Description																											
A	RW	EVENTS_END			The PDM has written the last sample specified by SAMPLE.MAXCNT (or the last sample after a STOP task has been received) to Data RAM																											
			NotGenerated	0	Event not generated																											
			Generated	1	Event generated																											

6.9.7.8 PUBLISH_STARTED

Address offset: 0x180

Publish configuration for event STARTED

Bit number	31	30	29	28	27	26	25	24	23	22	21	20	19	18	17	16	15	14	13	12	11	10	9	8	7	6	5	4	3	2	1	0
ID	B																															
Reset	0x00000000																															
Reset	0	0	0	0	0	0	0	0	0	0	0	0	0	0	0	0	0	0	0	0	0	0	0	0	0	0	0	0	0	0	0	0
ID	R/W	Field	Value ID	Value	Description																											
A	RW	CHIDX		[0..255]	DPPI channel that event STARTED will publish to																											
B	RW	EN																														
			Disabled	0	Disable publishing																											
			Enabled	1	Enable publishing																											

6.9.7.9 PUBLISH_STOPPED

Address offset: 0x184

Publish configuration for event STOPPED

Bit number	31	30	29	28	27	26	25	24	23	22	21	20	19	18	17	16	15	14	13	12	11	10	9	8	7	6	5	4	3	2	1	0
ID	B																															
Reset	0x00000000																															
Reset	0	0	0	0	0	0	0	0	0	0	0	0	0	0	0	0	0	0	0	0	0	0	0	0	0	0	0	0	0	0	0	0
ID	R/W	Field	Value ID	Value	Description																											
A	RW	CHIDX		[0..255]	DPPI channel that event STOPPED will publish to																											
B	RW	EN																														
			Disabled	0	Disable publishing																											
			Enabled	1	Enable publishing																											

6.9.7.10 PUBLISH_END

Address offset: 0x188

Publish configuration for event [END](#)

Bit number	31 30 29 28 27 26 25 24 23 22 21 20 19 18 17 16 15 14 13 12 11 10 9 8 7 6 5 4 3 2 1 0																														
ID	B																												A A A A A A A A		
Reset 0x00000000	0 0																														
ID	R/W	Field	Value ID	Value	Description																										
A	RW	CHIDX		[0..255]	DPPI channel that event END will publish to																										
B	RW	EN	Disabled	0	Disable publishing																										
			Enabled	1	Enable publishing																										

6.9.7.11 INTEN

Address offset: 0x300

Enable or disable interrupt

Bit number	31 30 29 28 27 26 25 24 23 22 21 20 19 18 17 16 15 14 13 12 11 10 9 8 7 6 5 4 3 2 1 0																														
ID																													C B A		
Reset 0x00000000	0 0																														
ID	R/W	Field	Value ID	Value	Description																										
A	RW	STARTED			Enable or disable interrupt for event STARTED																										
			Disabled	0	Disable																										
			Enabled	1	Enable																										
B	RW	STOPPED			Enable or disable interrupt for event STOPPED																										
			Disabled	0	Disable																										
			Enabled	1	Enable																										
C	RW	END			Enable or disable interrupt for event END																										
			Disabled	0	Disable																										
			Enabled	1	Enable																										

6.9.7.12 INTENSET

Address offset: 0x304

Enable interrupt

Bit number	31 30 29 28 27 26 25 24 23 22 21 20 19 18 17 16 15 14 13 12 11 10 9 8 7 6 5 4 3 2 1 0																														
ID																													C B A		
Reset 0x00000000	0 0																														
ID	R/W	Field	Value ID	Value	Description																										
A	RW	STARTED			Write '1' to enable interrupt for event STARTED																										
			Set	1	Enable																										
			Disabled	0	Read: Disabled																										
			Enabled	1	Read: Enabled																										
B	RW	STOPPED			Write '1' to enable interrupt for event STOPPED																										
			Set	1	Enable																										
			Disabled	0	Read: Disabled																										
			Enabled	1	Read: Enabled																										
C	RW	END			Write '1' to enable interrupt for event END																										
			Set	1	Enable																										

Bit number	31	30	29	28	27	26	25	24	23	22	21	20	19	18	17	16	15	14	13	12	11	10	9	8	7	6	5	4	3	2	1	0
ID																	C	B	A													
Reset 0x00000000	0	0	0	0	0	0	0	0	0	0	0	0	0	0	0	0	0	0	0	0	0	0	0	0	0	0	0	0	0	0		
ID	R/W	Field	Value ID	Value	Description																											
			Disabled	0	Read: Disabled																											
			Enabled	1	Read: Enabled																											

6.9.7.13 INTENCLR

Address offset: 0x308

Disable interrupt

Bit number	31	30	29	28	27	26	25	24	23	22	21	20	19	18	17	16	15	14	13	12	11	10	9	8	7	6	5	4	3	2	1	0
ID																	C	B	A													
Reset 0x00000000	0	0	0	0	0	0	0	0	0	0	0	0	0	0	0	0	0	0	0	0	0	0	0	0	0	0	0	0	0	0		
ID	R/W	Field	Value ID	Value	Description																											
A	RW	STARTED			Write '1' to disable interrupt for event STARTED																											
			Clear	1	Disable																											
			Disabled	0	Read: Disabled																											
			Enabled	1	Read: Enabled																											
B	RW	STOPPED			Write '1' to disable interrupt for event STOPPED																											
			Clear	1	Disable																											
			Disabled	0	Read: Disabled																											
			Enabled	1	Read: Enabled																											
C	RW	END			Write '1' to disable interrupt for event END																											
			Clear	1	Disable																											
			Disabled	0	Read: Disabled																											
			Enabled	1	Read: Enabled																											

6.9.7.14 ENABLE

Address offset: 0x500

PDM module enable register

Bit number	31	30	29	28	27	26	25	24	23	22	21	20	19	18	17	16	15	14	13	12	11	10	9	8	7	6	5	4	3	2	1	0
ID																			A													
Reset 0x00000000	0	0	0	0	0	0	0	0	0	0	0	0	0	0	0	0	0	0	0	0	0	0	0	0	0	0	0	0	0	0		
ID	R/W	Field	Value ID	Value	Description																											
A	RW	ENABLE			Enable or disable PDM module																											
			Disabled	0	Disable																											
			Enabled	1	Enable																											

6.9.7.15 PDMCLKCTRL

Address offset: 0x504

PDM clock generator control

Bit number	31	30	29	28	27	26	25	24	23	22	21	20	19	18	17	16	15	14	13	12	11	10	9	8	7	6	5	4	3	2	1	0
ID	A	A	A	A	A	A	A	A	A	A	A	A	A	A	A	A	A	A	A	A	A	A	A	A	A	A	A	A	A	A	A	A
Reset 0x08400000	0	0	0	0	1	0	0	0	0	1	0	0	0	0	0	0	0	0	0	0	0	0	0	0	0	0	0	0	0	0	0	
ID	R/W	Field	Value ID	Value	Description																											
A	RW	FREQ			PDM_CLK frequency configuration.																											
			1000K	0x08000000	PDM_CLK = 32 MHz / 32 = 1.000 MHz																											
			Default	0x08400000	PDM_CLK = 32 MHz / 31 = 1.032 MHz. Nominal clock for RATIO=Ratio64.																											
			1067K	0x08800000	PDM_CLK = 32 MHz / 30 = 1.067 MHz																											
			1231K	0x09800000	PDM_CLK = 32 MHz / 26 = 1.231 MHz																											
			1280K	0x0A000000	PDM_CLK = 32 MHz / 25 = 1.280 MHz. Nominal clock for RATIO=Ratio80.																											
			1333K	0x0A800000	PDM_CLK = 32 MHz / 24 = 1.333 MHz																											

6.9.7.16 MODE

Address offset: 0x508

Defines the routing of the connected PDM microphones' signals

Bit number	31	30	29	28	27	26	25	24	23	22	21	20	19	18	17	16	15	14	13	12	11	10	9	8	7	6	5	4	3	2	1	0	
ID																																B	A
Reset 0x00000000	0	0	0	0	0	0	0	0	0	0	0	0	0	0	0	0	0	0	0	0	0	0	0	0	0	0	0	0	0	0	0	0	
ID	R/W	Field	Value ID	Value	Description																												
A	RW	OPERATION			Mono or stereo operation																												
			Stereo	0	Sample and store one pair (left + right) of 16-bit samples per RAM word R=[31:16]; L=[15:0]																												
			Mono	1	Sample and store two successive left samples (16 bits each) per RAM word L1=[31:16]; L0=[15:0]																												
B	RW	EDGE			Defines on which PDM_CLK edge left (or mono) is sampled																												
			LeftFalling	0	Left (or mono) is sampled on falling edge of PDM_CLK																												
			LeftRising	1	Left (or mono) is sampled on rising edge of PDM_CLK																												

6.9.7.17 GAINL

Address offset: 0x518

Left output gain adjustment

Bit number	31	30	29	28	27	26	25	24	23	22	21	20	19	18	17	16	15	14	13	12	11	10	9	8	7	6	5	4	3	2	1	0	
ID																												A	A	A	A	A	A
Reset 0x00000028	0 1 0 1 0 0 0																																
ID	R/W	Field	Value ID	Value	Description																												
A	RW	GAINL			Left output gain adjustment, in 0.5 dB steps, around the default module gain (see electrical parameters)																												
					0x00 -20 dB gain adjust																												
					0x01 -19.5 dB gain adjust																												
					(...)																												
					0x27 -0.5 dB gain adjust																												
					0x28 0 dB gain adjust																												
					0x29 +0.5 dB gain adjust																												
					(...)																												
					0x4F +19.5 dB gain adjust																												
					0x50 +20 dB gain adjust																												
			MinGain	0x00	-20 dB gain adjustment (minimum)																												
			DefaultGain	0x28	0 dB gain adjustment																												
			MaxGain	0x50	+20 dB gain adjustment (maximum)																												

6.9.7.18 GAINR

Address offset: 0x51C

Right output gain adjustment

Bit number	31	30	29	28	27	26	25	24	23	22	21	20	19	18	17	16	15	14	13	12	11	10	9	8	7	6	5	4	3	2	1	0	
ID																												A	A	A	A	A	A
Reset 0x00000028	0 1 0 1 0 0 0																																
ID	R/W	Field	Value ID	Value	Description																												
A	RW	GAINR			Right output gain adjustment, in 0.5 dB steps, around the default module gain (see electrical parameters)																												
			MinGain	0x00	-20 dB gain adjustment (minimum)																												
			DefaultGain	0x28	0 dB gain adjustment																												
			MaxGain	0x50	+20 dB gain adjustment (maximum)																												

6.9.7.19 RATIO

Address offset: 0x520

Selects the ratio between PDM_CLK and output sample rate. Change PDMCLKCTRL accordingly.

Bit number	31	30	29	28	27	26	25	24	23	22	21	20	19	18	17	16	15	14	13	12	11	10	9	8	7	6	5	4	3	2	1	0
ID																												A				
Reset 0x00000000	0 0																															
ID	R/W	Field	Value ID	Value	Description																											
A	RW	RATIO			Selects the ratio between PDM_CLK and output sample rate																											
			Ratio64	0	Ratio of 64																											
			Ratio80	1	Ratio of 80																											

6.9.7.20 PSEL.CLK

Address offset: 0x540

Pin number configuration for PDM CLK signal

Bit number	31 30 29 28 27 26 25 24 23 22 21 20 19 18 17 16 15 14 13 12 11 10 9 8 7 6 5 4 3 2 1 0																														
ID	B																											A A A A			
Reset 0xFFFFFFFF	1 1																														
ID	R/W	Field	Value ID	Value	Description																										
A	RW	PIN		[0..31]	Pin number																										
B	RW	CONNECT			Connection																										
			Disconnected	1	Disconnect																										
			Connected	0	Connect																										

6.9.7.21 PSEL.DIN

Address offset: 0x544

Pin number configuration for PDM DIN signal

Bit number	31 30 29 28 27 26 25 24 23 22 21 20 19 18 17 16 15 14 13 12 11 10 9 8 7 6 5 4 3 2 1 0																														
ID	B																											A A A A			
Reset 0xFFFFFFFF	1 1																														
ID	R/W	Field	Value ID	Value	Description																										
A	RW	PIN		[0..31]	Pin number																										
B	RW	CONNECT			Connection																										
			Disconnected	1	Disconnect																										
			Connected	0	Connect																										

6.9.7.22 SAMPLE.PTR

Address offset: 0x560

RAM address pointer to write samples to with EasyDMA

Bit number	31 30 29 28 27 26 25 24 23 22 21 20 19 18 17 16 15 14 13 12 11 10 9 8 7 6 5 4 3 2 1 0																														
ID	A A																														
Reset 0x00000000	0 0																														
ID	R/W	Field	Value ID	Value	Description																										
A	RW	SAMPLEPTR			Address to write PDM samples to over DMA																										

Note: See the memory chapter for details about which memories are available for EasyDMA.

6.9.7.23 SAMPLE.MAXCNT

Address offset: 0x564

Number of samples to allocate memory for in EasyDMA mode

Bit number	31 30 29 28 27 26 25 24 23 22 21 20 19 18 17 16 15 14 13 12 11 10 9 8 7 6 5 4 3 2 1 0																														
ID																												A A			
Reset 0x00000000	0 0																														
ID	R/W	Field	Value ID	Value	Description																										
A	RW	BUFSIZE		[0..32767]	Length of DMA RAM allocation in number of samples																										

6.9.8 Electrical specification

6.9.8.1 PDM Electrical Specification

Symbol	Description	Min.	Typ.	Max.	Units
$f_{\text{PDM,CLK},64}$	PDM clock speed. PDMCLKCTRL = Default (Setting needed for 16 MHz sample frequency @ RATIO = Ratio64)		1.032		MHz
$f_{\text{PDM,CLK},80}$	PDM clock speed. PDMCLKCTRL = 1280K (Setting needed for 16 MHz sample frequency @ RATIO = Ratio80)		1.28		MHz
$t_{\text{PDM,JITTER}}$	Jitter in PDM clock output			20	ns
$T_{\text{dPDM,CLK}}$	PDM clock duty cycle	40	50	60	%
$t_{\text{PDM,DATA}}$	Decimation filter delay			5	ms
$t_{\text{PDM,cv}}$	Allowed clock edge to data valid			125	ns
$t_{\text{PDM,ci}}$	Allowed (other) clock edge to data invalid	0			ns
$t_{\text{PDM,s}}$	Data setup time at $f_{\text{PDM,CLK}}=1.024$ MHz or 1.280 MHz	65			ns
$t_{\text{PDM,h}}$	Data hold time at $f_{\text{PDM,CLK}}=1.024$ MHz or 1.280 MHz	0			ns
$G_{\text{PDM,default}}$	Default (reset) absolute gain of the PDM module		3.2		dB

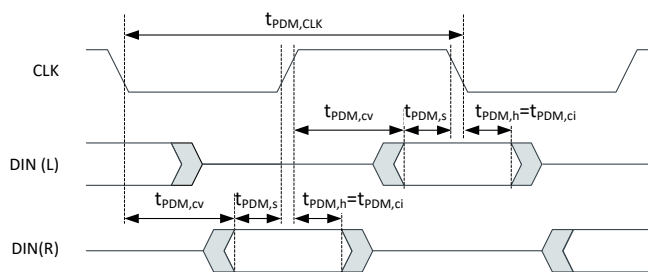

Figure 46: PDM timing diagram

6.10 PWM — Pulse width modulation

The pulse width modulation (PWM) module enables the generation of pulse width modulated signals on GPIO. The module implements an up or up-and-down counter with four PWM channels that drive assigned GPIOs.

The following are the main features of a PWM module:

- Programmable PWM frequency
- Up to four PWM channels with individual polarity and duty cycle values
- Edge or center-aligned pulses across PWM channels
- Multiple duty cycle arrays (sequences) defined in RAM
- Autonomous and glitch-free update of duty cycle values directly from memory through EasyDMA (no CPU involvement)
- Change of polarity, duty cycle, and base frequency possibly on every PWM period
- RAM sequences can be repeated or connected into loops

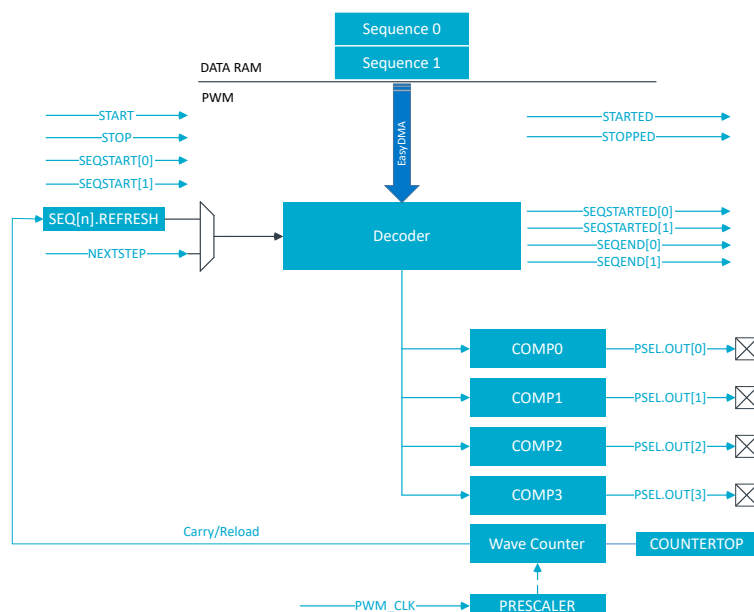

Figure 47: PWM module

6.10.1 Wave counter

The wave counter is responsible for generating the pulses, at a duty cycle that depends on the compare values and at a frequency that depends on COUNTERTOP.

There is one common 15-bit counter with four compare channels. Thus, all four channels will share the same period (PWM frequency) but can have individual duty cycle and polarity. The polarity is set by the most significant bit (MSB) of the value read from RAM (see figure [Decoder memory access modes](#) on page 232). When the MSB bit is high (FallingEdge polarity), OUT[n] starts high to become low during the given PWM cycle, whereas the inverse occurs for RisingEdge polarity. Whether the counter counts up, or up and down, is controlled by the MODE register.

The timer top value is controlled by the COUNTERTOP register. This register value, in conjunction with the selected PRESCALER of the PWM_CLK, will result in a given PWM period. A COUNTERTOP value smaller than the compare setting will result in a state where no PWM edges are generated. OUT[n] is held high, given that the polarity is set to FallingEdge. All compare registers are internal and can only be configured through decoder presented later. COUNTERTOP can be safely written at any time.

Sampling follows the START task. If DECODER.LOAD=WaveForm, the register value is ignored and taken from RAM instead (see section [Decoder with EasyDMA](#) on page 232 for more details). If DECODER.LOAD is anything else than the WaveForm, it is sampled following a STARTSEQ[n] task and when loading a new value from RAM during a sequence playback.

The following figure shows the counter operating in up mode (MODE=PWM_MODE_Up), with two PWM channels with the same frequency but different duty cycle:

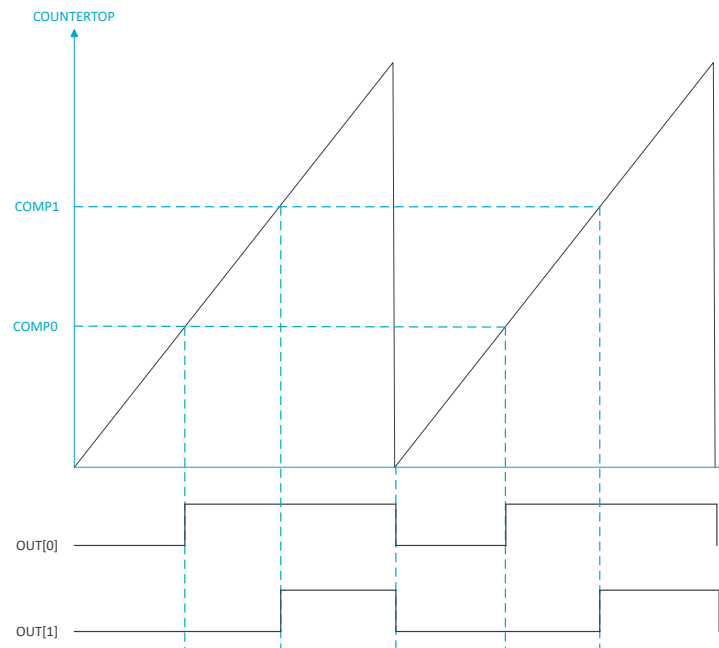

Figure 48: PWM counter in up mode example - RisingEdge polarity

The counter is automatically reset to zero when COUNTERTOP is reached and OUT[n] will invert. OUT[n] is held low if the compare value is 0 and held high if set to COUNTERTOP, given that the polarity is set to FallingEdge. Counter running in up mode results in pulse widths that are edge-aligned. The following is the code for the counter in up mode example:

```
uint16_t pwm_seq[4] = {PWM_CH0_DUTY, PWM_CH1_DUTY, PWM_CH2_DUTY, PWM_CH3_DUTY};
NRF_PWM0->PSEL.OUT[0] = (first_pin << PWM_PSEL_OUT_PIN_Pos) |
    (PWM_PSEL_OUT_CONNECT_Connected <<
        PWM_PSEL_OUT_CONNECT_Pos);
NRF_PWM0->PSEL.OUT[1] = (second_pin << PWM_PSEL_OUT_PIN_Pos) |
    (PWM_PSEL_OUT_CONNECT_Connected <<
        PWM_PSEL_OUT_CONNECT_Pos);
NRF_PWM0->ENABLE = (PWM_ENABLE_ENABLE_Enabled << PWM_ENABLE_ENABLE_Pos);
NRF_PWM0->MODE = (PWM_MODE_UPDOWN_Up << PWM_MODE_UPDOWN_Pos);
NRF_PWM0->PRESCALER = (PWM_PRESCALER_PRESCALER_DIV_1 <<
    PWM_PRESCALER_PRESCALER_Pos);
NRF_PWM0->COUNTERTOP = (16000 << PWM_COUNTERTOP_COUNTERTOP_Pos); //1 msec
NRF_PWM0->LOOP = (PWM_LOOP_CNT_Disabled << PWM_LOOP_CNT_Pos);
NRF_PWM0->DECODER = (PWM_DECODER_LOAD_Individual << PWM_DECODER_LOAD_Pos) |
    (PWM_DECODER_MODE_RefreshCount << PWM_DECODER_MODE_Pos);
NRF_PWM0->SEQ[0].PTR = ((uint32_t) (pwm_seq) << PWM_SEQ_PTR_PTR_Pos);
NRF_PWM0->SEQ[0].CNT = ((sizeof(pwm_seq) / sizeof(uint16_t)) <<
    PWM_SEQ_CNT_CNT_Pos);

NRF_PWM0->SEQ[0].REFRESH = 0;
NRF_PWM0->SEQ[0].ENDDelay = 0;
NRF_PWM0->TASKS_SEQSTART[0] = 1;
```

When the counter is running in up mode, the following formula can be used to compute the PWM period and the step size:

$$\text{PWM period: } T_{\text{PWM(Up)}} = T_{\text{PWM_CLK}} * \text{COUNTERTOP}$$

Step width/Resolution: $T_{steps} = T_{PWM_CLK}$

The following figure shows the counter operating in up-and-down mode (MODE=PWM_MODE_UpAndDown), with two PWM channels with the same frequency but different duty cycle and output polarity:

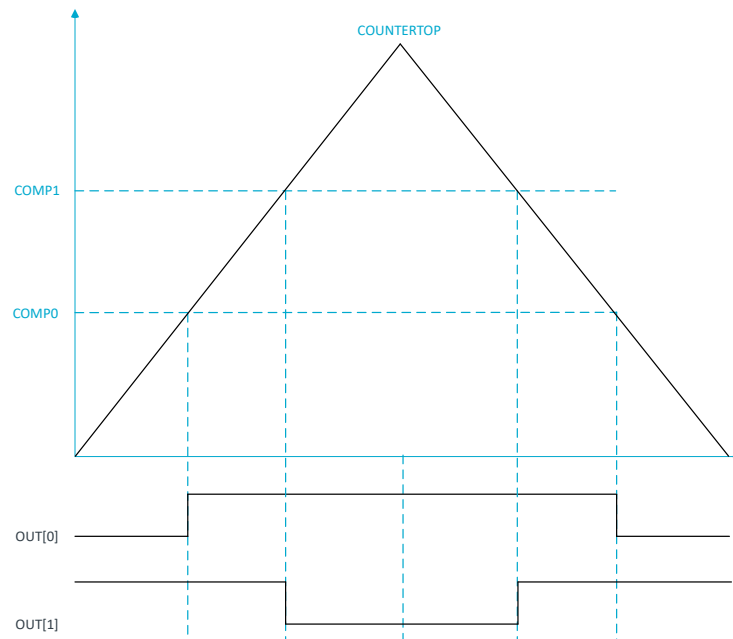

Figure 49: PWM counter in up-and-down mode example

The counter starts decrementing to zero when COUNTERTOP is reached and will invert the OUT[n] when compare value is hit for the second time. This results in a set of pulses that are center-aligned. The following is the code for the counter in up-and-down mode example:

```
uint16_t pwm_seq[4] = {PWM_CH0_DUTY, PWM_CH1_DUTY, PWM_CH2_DUTY, PWM_CH3_DUTY};
NRF_PWM0->PSEL.OUT[0] = (first_pin << PWM_PSEL_OUT_PIN_Pos) |
    (PWM_PSEL_OUT_CONNECT_Connected <<
        PWM_PSEL_OUT_CONNECT_Pos);
NRF_PWM0->PSEL.OUT[1] = (second_pin << PWM_PSEL_OUT_PIN_Pos) |
    (PWM_PSEL_OUT_CONNECT_Connected <<
        PWM_PSEL_OUT_CONNECT_Pos);
NRF_PWM0->ENABLE = (PWM_ENABLE_ENABLE_Enabled << PWM_ENABLE_ENABLE_Pos);
NRF_PWM0->MODE = (PWM_MODE_UPDOWN_UpAndDown << PWM_MODE_UPDOWN_Pos);
NRF_PWM0->PRESCALER = (PWM_PRESCALER_PRESCALER_DIV_1 <<
    PWM_PRESCALER_PRESCALER_Pos);
NRF_PWM0->COUNTERTOP = (16000 << PWM_COUNTERTOP_COUNTERTOP_Pos); //1 msec
NRF_PWM0->LOOP = (PWM_LOOP_CNT_Disabled << PWM_LOOP_CNT_Pos);
NRF_PWM0->DECODER = (PWM_DECODER_LOAD_Individual << PWM_DECODER_LOAD_Pos) |
    (PWM_DECODER_MODE_RefreshCount << PWM_DECODER_MODE_Pos);
NRF_PWM0->SEQ[0].PTR = ((uint32_t)(pwm_seq) << PWM_SEQ_PTR_PTR_Pos);
NRF_PWM0->SEQ[0].CNT = ((sizeof(pwm_seq) / sizeof(uint16_t)) <<
    PWM_SEQ_CNT_CNT_Pos);
NRF_PWM0->SEQ[0].REFRESH = 0;
NRF_PWM0->SEQ[0].ENDDelay = 0;
NRF_PWM0->TASKS_SEQSTART[0] = 1;
```

When the counter is running in up-and-down mode, the following formula can be used to compute the PWM period and the step size:

$$T_{PWM(Up\ And\ Down)} = T_{PWM_CLK} * 2 * COUNTERTOP$$

Step width/Resolution: $T_{steps} = T_{PWM_CLK} * 2$

6.10.2 Decoder with EasyDMA

The decoder uses EasyDMA to take PWM parameters stored in RAM and update the internal compare registers of the wave counter, based on the mode of operation.

PWM parameters are organized into a sequence containing at least one half word (16 bit). Its most significant bit[15] denotes the polarity of the OUT[n] while bit[14:0] is the 15-bit compare value.

Bit number	31 30 29 28 27 26 25 24 23 22 21 20 19 18 17 16 15 14 13 12 11 10 9 8 7 6 5 4 3 2 1 0																														
Id	B A A A A A A A A A A A A A A A A																														
Reset 0x00000000	0 0																														
Id	RW	Field	Value	Id	Value	Description																									
A	RW	COMPARE				Duty cycle setting - value loaded to internal compare register																									
B	RW	POLARITY				Edge polarity of GPIO.																									
			RisingEdge	0		First edge within the PWM period is rising																									
			FallingEdge	1		First edge within the PWM period is falling																									

The DECODER register controls how the RAM content is interpreted and loaded into the internal compare registers. The LOAD field controls if the RAM values are loaded to all compare channels, or to update a group or all channels with individual values. The following figure illustrates how parameters stored in RAM are organized and routed to various compare channels in different modes:

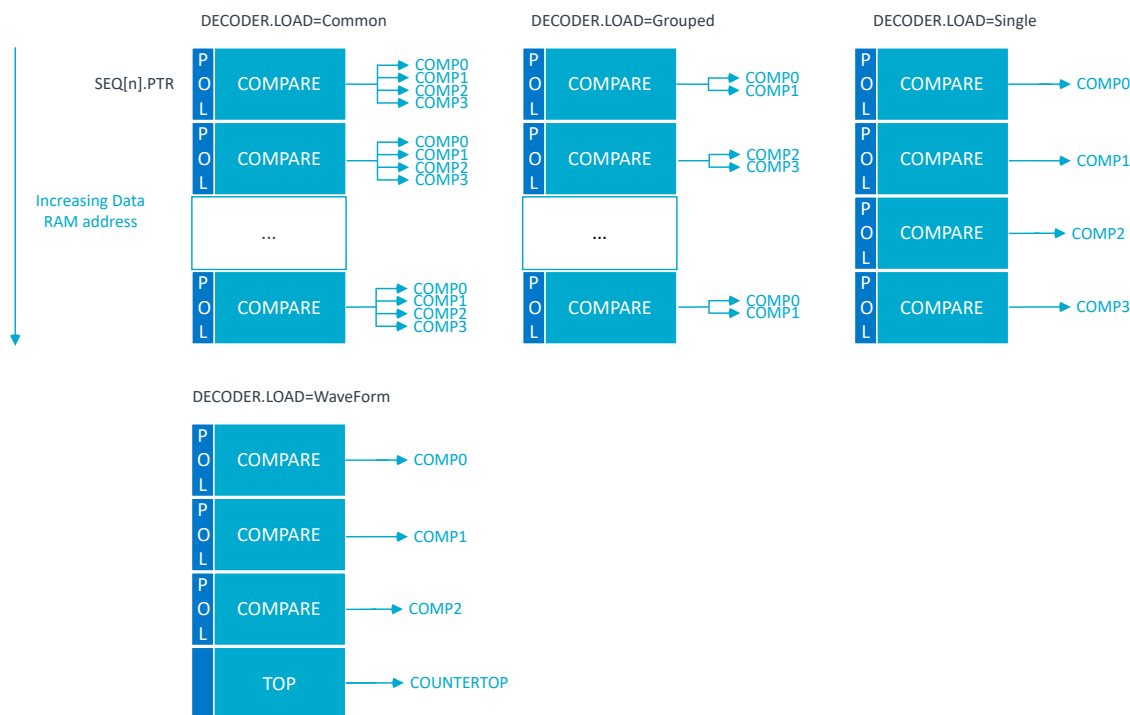

Figure 50: Decoder memory access modes

A special mode of operation is available when DECODER.LOAD is set to WaveForm. In this mode, up to three PWM channels can be enabled - OUT[0] to OUT[2]. In RAM, four values are loaded at a time: the first, second and third location are used to load the values, and the fourth RAM location is used to load

the COUNTERTOP register. This way one can have up to three PWM channels with a frequency base that changes on a per PWM period basis. This mode of operation is useful for arbitrary wave form generation in applications, such as LED lighting.

The register SEQ[n].REFRESH=N (one per sequence n=0 or 1) will instruct a new RAM stored pulse width value on every (N+1)th PWM period. Setting the register to zero will result in a new duty cycle update every PWM period, as long as the minimum PWM period is observed.

Note that registers SEQ[n].REFRESH and SEQ[n].ENDDELAY are ignored when DECODER.MODE=NextStep. The next value is loaded upon every received NEXTSTEP task.

SEQ[n].PTR is the pointer used to fetch COMPARE values from RAM. If the SEQ[n].PTR is not pointing to a RAM region, an EasyDMA transfer may result in a HardFault or RAM corruption. See [Memory](#) on page 23 for more information about the different memory regions. After the SEQ[n].PTR is set to the desired RAM location, the SEQ[n].CNT register must be set to the number of 16-bit half words in the sequence. It is important to observe that the Grouped mode requires one half word per group, while the Single mode requires one half word per channel, thus increasing the RAM size occupation. If PWM generation is not running when the SEQSTART[n] task is triggered, the task will load the first value from RAM and then start the PWM generation. A SEQSTARTED[n] event is generated as soon as the EasyDMA has read the first PWM parameter from RAM and the wave counter has started executing it. When LOOP.CNT=0, sequence n=0 or 1 is played back once. After the last value in the sequence has been loaded and started executing, a SEQEND[n] event is generated. The PWM generation will then continue with the last loaded value. The following figure illustrates an example of a simple playback.

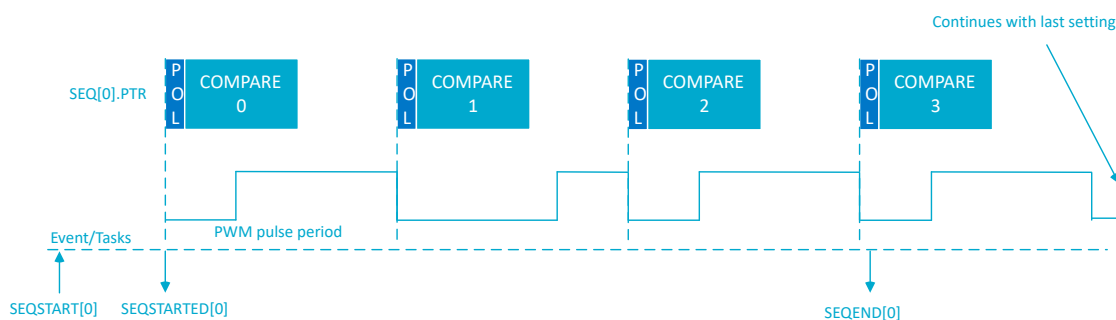

Figure 51: Simple sequence example

The following source code is used for configuration and timing details in a sequence where only sequence 0 is used and only run once with a new PWM duty cycle for each period.

```

NRF_PWM0->PSEL.OUT[0] = (first_pin << PWM_PSEL_OUT_PIN_Pos) |
                        (PWM_PSEL_OUT_CONNECT_Connected <<
                          PWM_PSEL_OUT_CONNECT_Pos);
NRF_PWM0->ENABLE      = (PWM_ENABLE_ENABLE_Enabled << PWM_ENABLE_ENABLE_Pos);
NRF_PWM0->MODE        = (PWM_MODE_UPDOWN_Up << PWM_MODE_UPDOWN_Pos);
NRF_PWM0->PRESCALER   = (PWM_PRESCALER_PRESCALER_DIV_1 <<
                          PWM_PRESCALER_PRESCALER_Pos);
NRF_PWM0->COUNTERTOP  = (16000 << PWM_COUNTERTOP_COUNTERTOP_Pos); //1 msec
NRF_PWM0->LOOP        = (PWM_LOOP_CNT_Disabled << PWM_LOOP_CNT_Pos);
NRF_PWM0->DECODER     = (PWM_DECODER_LOAD_Common << PWM_DECODER_LOAD_Pos) |
                        (PWM_DECODER_MODE_RefreshCount << PWM_DECODER_MODE_Pos);
NRF_PWM0->SEQ[0].PTR  = ((uint32_t)(seq0_ram) << PWM_SEQ_PTR_PTR_Pos);
NRF_PWM0->SEQ[0].CNT  = ((sizeof(seq0_ram) / sizeof(uint16_t)) <<
                          PWM_SEQ_CNT_CNT_Pos);

NRF_PWM0->SEQ[0].REFRESH = 0;
NRF_PWM0->SEQ[0].ENDDelay = 0;
NRF_PWM0->TASKS_SEQSTART[0] = 1;

```

To completely stop the PWM generation and force the associated pins to a defined state, a STOP task can be triggered at any time. A STOPPED event is generated when the PWM generation has stopped at the end of the currently running PWM period, and the pins go into their idle state as defined in GPIO OUT register. PWM generation can then only be restarted through a SEQSTART[n] task. SEQSTART[n] will resume PWM generation after having loaded the first value from the RAM buffer defined in the SEQ[n].PTR register.

The following table indicates when specific registers get sampled by the hardware. Care should be taken when updating these registers to avoid that values are applied earlier than expected.

Register	Taken into account by hardware	Recommended (safe) update
SEQ[n].PTR	When sending the SEQSTART[n] task	After having received the SEQSTARTED[n] event
SEQ[n].CNT	When sending the SEQSTART[n] task	After having received the SEQSTARTED[n] event
SEQ[0].ENDDelay	When sending the SEQSTART[0] task Every time a new value from sequence [0] has been loaded from RAM and gets applied to the Wave Counter (indicated by the PWMPERIODEND event)	Before starting sequence [0] through a SEQSTART[0] task When no more value from sequence [0] gets loaded from RAM (indicated by the SEQEND[0] event) At any time during sequence [1] (which starts when the SEQSTARTED[1] event is generated)
SEQ[1].ENDDelay	When sending the SEQSTART[1] task Every time a new value from sequence [1] has been loaded from RAM and gets applied to the Wave Counter (indicated by the PWMPERIODEND event)	Before starting sequence [1] through a SEQSTART[1] task When no more value from sequence [1] gets loaded from RAM (indicated by the SEQEND[1] event) At any time during sequence [0] (which starts when the SEQSTARTED[0] event is generated)
SEQ[0].REFRESH	When sending the SEQSTART[0] task Every time a new value from sequence [0] has been loaded from RAM and gets applied to the Wave Counter (indicated by the PWMPERIODEND event)	Before starting sequence [0] through a SEQSTART[0] task At any time during sequence [1] (which starts when the SEQSTARTED[1] event is generated)
SEQ[1].REFRESH	When sending the SEQSTART[1] task Every time a new value from sequence [1] has been loaded from RAM and gets applied to the Wave Counter (indicated by the PWMPERIODEND event)	Before starting sequence [1] through a SEQSTART[1] task At any time during sequence [0] (which starts when the SEQSTARTED[0] event is generated)
COUNTERTOP	In DECODER.LOAD=WaveForm: this register is ignored. In all other LOAD modes: at the end of current PWM period (indicated by the PWMPERIODEND event)	Before starting PWM generation through a SEQSTART[n] task After a STOP task has been triggered, and the STOPPED event has been received.
MODE	Immediately	Before starting PWM generation through a SEQSTART[n] task After a STOP task has been triggered, and the STOPPED event has been received.
DECODER	Immediately	Before starting PWM generation through a SEQSTART[n] task After a STOP task has been triggered, and the STOPPED event has been received.
PRESCALER	Immediately	Before starting PWM generation through a SEQSTART[n] task After a STOP task has been triggered, and the STOPPED event has been received.
LOOP	Immediately	Before starting PWM generation through a SEQSTART[n] task After a STOP task has been triggered, and the STOPPED event has been received.
PSEL.OUT[n]	Immediately	Before enabling the PWM instance through the ENABLE register

Table 27: When to safely update PWM registers

Note: SEQ[n].REFRESH and SEQ[n].ENDDelay are ignored at the end of a complex sequence, indicated by a LOOPSDONE event. The reason for this is that the last value loaded from RAM is maintained until further action from software (restarting a new sequence or stopping PWM generation).

The following figure shows a more complex example using the register [LOOP](#) on page 250.

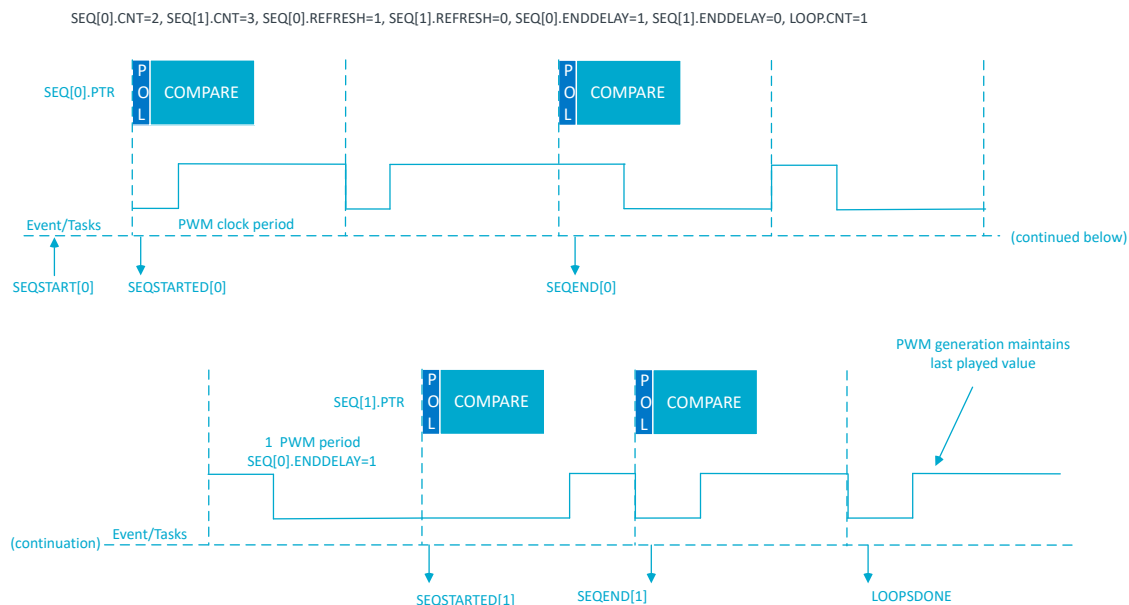

Figure 52: Example using two sequences

In this case, an automated playback takes place, consisting of SEQ[0], delay 0, SEQ[1], delay 1, then again SEQ[0], etc. The user can choose to start a complex playback with SEQ[0] or SEQ[1] through sending the SEQSTART[0] or SEQSTART[1] task. The complex playback always ends with delay 1.

The two sequences 0 and 1 are defined by the addresses of value tables in RAM (pointed to by SEQ[n].PTR) and the buffer size (SEQ[n].CNT). The rate at which a new value is loaded is defined individually for each sequence by SEQ[n].REFRESH. The chaining of sequence 1 following the sequence 0 is implicit, the LOOP.CNT register allows the chaining of sequence 1 to sequence 0 for a determined number of times. In other words, it allows to repeat a complex sequence a number of times in a fully automated way.

In the following code example, sequence 0 is defined with SEQ[0].REFRESH set to 1, meaning that a new PWM duty cycle is pushed every second PWM period. This complex sequence is started with the SEQSTART[0] task, so SEQ[0] is played first. Since SEQ[0].ENDDDELAY=1 there will be one PWM period delay between last period on sequence 0 and the first period on sequence 1. Since SEQ[1].ENDDDELAY=0 there is no delay 1, so SEQ[0] would be started immediately after the end of SEQ[1]. However, as LOOP.CNT is

1, the playback stops after having played SEQ[1] only once, and both SEQEND[1] and LOOPSDONE are generated (their order is not guaranteed in this case).

```

NRF_PWM0->PSEL.OUT[0] = (first_pin << PWM_PSEL_OUT_PIN_Pos) |
                        (PWM_PSEL_OUT_CONNECT_Connected <<
                         PWM_PSEL_OUT_CONNECT_Pos);
NRF_PWM0->ENABLE      = (PWM_ENABLE_ENABLE_Enabled << PWM_ENABLE_ENABLE_Pos);
NRF_PWM0->MODE        = (PWM_MODE_UPDOWN_Up << PWM_MODE_UPDOWN_Pos);
NRF_PWM0->PRESCALER   = (PWM_PRESCALER_PRESCALER_DIV_1 <<
                         PWM_PRESCALER_PRESCALER_Pos);
NRF_PWM0->COUNTERTOP  = (16000 << PWM_COUNTERTOP_COUNTERTOP_Pos); //1 msec
NRF_PWM0->LOOP        = (1 << PWM_LOOP_CNT_Pos);
NRF_PWM0->DECODER     = (PWM_DECODER_LOAD_Common << PWM_DECODER_LOAD_Pos) |
                        (PWM_DECODER_MODE_RefreshCount << PWM_DECODER_MODE_Pos);
NRF_PWM0->SEQ[0].PTR  = ((uint32_t)(seq0_ram) << PWM_SEQ_PTR_PTR_Pos);
NRF_PWM0->SEQ[0].CNT  = ((sizeof(seq0_ram) / sizeof(uint16_t)) <<
                         PWM_SEQ_CNT_CNT_Pos);

NRF_PWM0->SEQ[0].REFRESH = 1;
NRF_PWM0->SEQ[0].ENDDELAY = 1;
NRF_PWM0->SEQ[1].PTR  = ((uint32_t)(seq1_ram) << PWM_SEQ_PTR_PTR_Pos);
NRF_PWM0->SEQ[1].CNT  = ((sizeof(seq1_ram) / sizeof(uint16_t)) <<
                         PWM_SEQ_CNT_CNT_Pos);

NRF_PWM0->SEQ[1].REFRESH = 0;
NRF_PWM0->SEQ[1].ENDDELAY = 0;
NRF_PWM0->TASKS_SEQSTART[0] = 1;

```

The decoder can also be configured to asynchronously load new PWM duty cycle. If the DECODER.MODE register is set to NextStep, then the NEXTSTEP task will cause an update of internal compare registers on the next PWM period.

The following figures provide an overview of each part of an arbitrary sequence, in various modes (LOOP.CNT=0 and LOOP.CNT>0). In particular, the following are represented:

- Initial and final duty cycle on the PWM output(s)
- Chaining of SEQ[0] and SEQ[1] if LOOP.CNT>0
- Influence of registers on the sequence
- Events generated during a sequence
- DMA activity (loading of next value and applying it to the output(s))

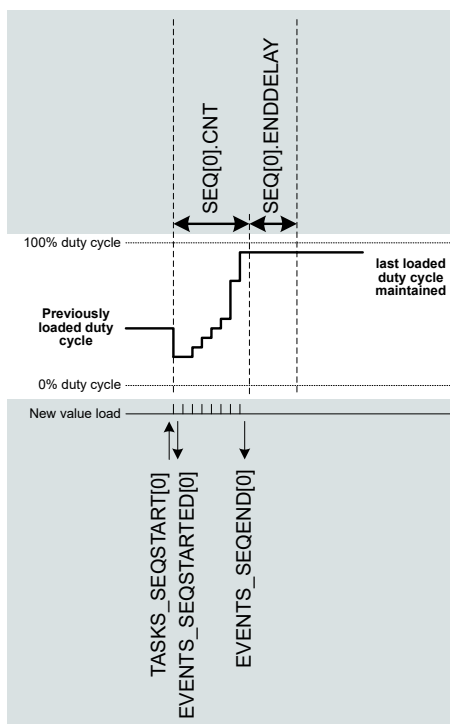

Figure 53: Single shot (LOOP.CNT=0)

Note: The single-shot example also applies to SEQ[1]. Only SEQ[0] is represented for simplicity.

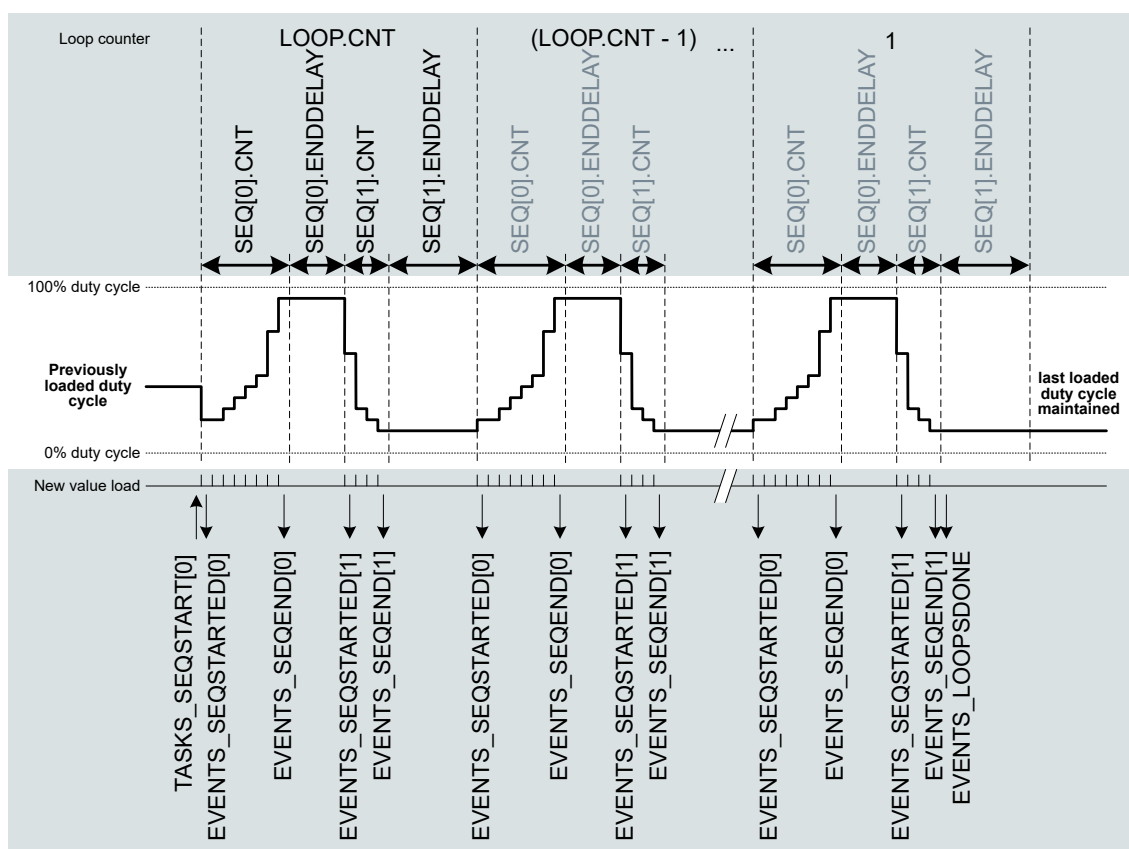

Figure 54: Complex sequence (LOOP.CNT>0) starting with SEQ[0]

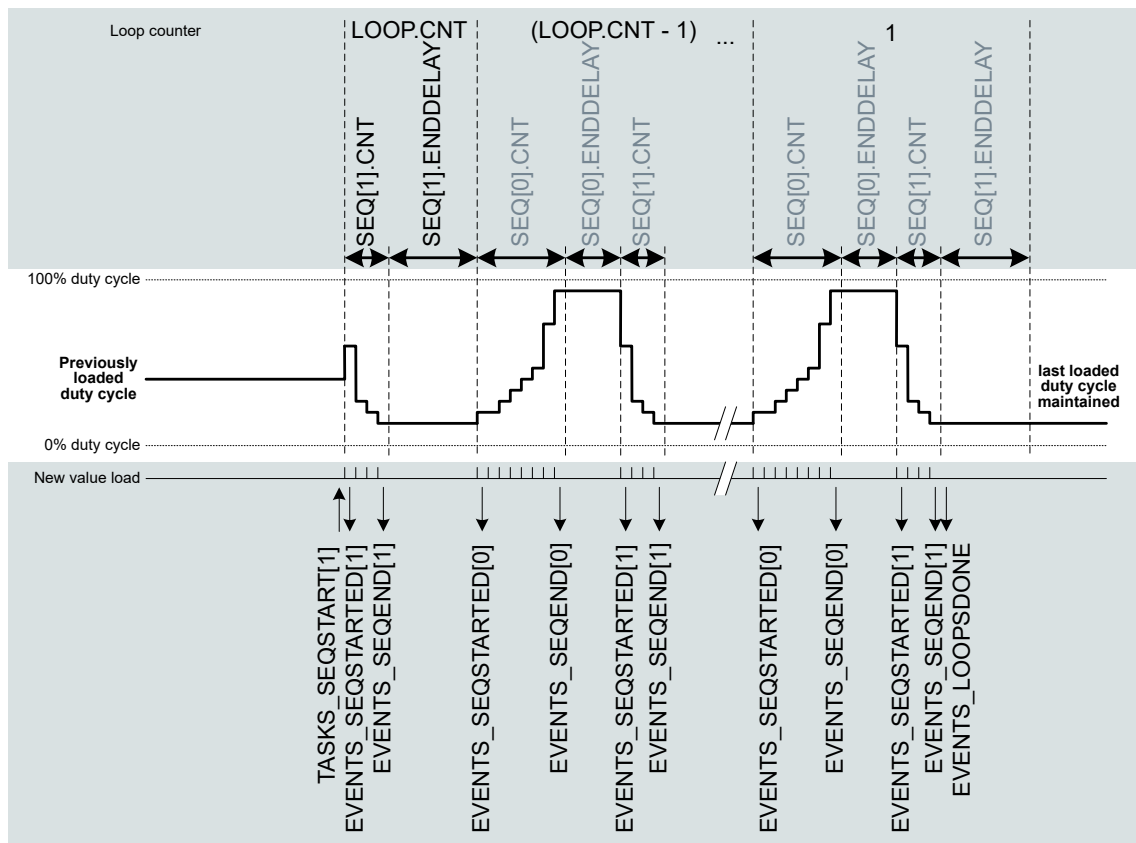

Figure 55: Complex sequence ($LOOP.CNT > 0$) starting with $SEQ[1]$

Note: If a sequence is in use in a simple or complex sequence, it must have a length of $SEQ[n].CNT > 0$.

This example shows how the PWM module can be configured to repeat a single sequence until stopped.

```

NRF_PWM0->PSEL.OUT[0] = (first_pin << PWM_PSEL_OUT_PIN_Pos) |
                        (PWM_PSEL_OUT_CONNECT_Connected <<
                         PWM_PSEL_OUT_CONNECT_Pos);
NRF_PWM0->ENABLE      = (PWM_ENABLE_ENABLE_Enabled << PWM_ENABLE_ENABLE_Pos);
NRF_PWM0->MODE        = (PWM_MODE_UPDOWN_Up << PWM_MODE_UPDOWN_Pos);
NRF_PWM0->PRESCALER   = (PWM_PRESCALER_PRESCALER_DIV_1 <<
                         PWM_PRESCALER_PRESCALER_Pos);
NRF_PWM0->COUNTERTOP  = (16000 << PWM_COUNTERTOP_COUNTERTOP_Pos); //1 msec
// Enable the shortcut from LOOPSDONE event to SEQSTART1 task for infinite loop
NRF_PWM0->SHORTS      = (PWM_SHORTS_LOOPSDONE_SEQSTART1_Enabled <<
                         PWM_SHORTS_LOOPSDONE_SEQSTART1_Pos);
// LOOP_CNT must be greater than 0 for the LOOPSDONE event to trigger and enable looping
NRF_PWM0->LOOP        = (1 << PWM_LOOP_CNT_Pos);
NRF_PWM0->DECODER     = (PWM_DECODER_LOAD_Common << PWM_DECODER_LOAD_Pos) |
                        (PWM_DECODER_MODE_RefreshCount << PWM_DECODER_MODE_Pos);
// To repeat a single sequence until stopped, it must be configured in SEQ[1]
NRF_PWM0->SEQ[1].PTR  = ((uint32_t)(seq0_ram) << PWM_SEQ_PTR_PTR_Pos);
NRF_PWM0->SEQ[1].CNT  = ((sizeof(seq0_ram) / sizeof(uint16_t)) <<
                         PWM_SEQ_CNT_CNT_Pos);
NRF_PWM0->SEQ[1].REFRESH = 0;
NRF_PWM0->SEQ[1].ENDDDELAY = 0;
NRF_PWM0->TASKS_SEQSTART[1] = 1;

```

6.10.3 Limitations

The previous compare value is repeated if the PWM period is shorter than the time it takes for the EasyDMA to retrieve from RAM and update the internal compare registers. This is to ensure a glitch-free operation even for very short PWM periods.

Only SEQ[1] can trigger the **LOOPSDONE** event upon completion, not SEQ[0]. This requires looping to be enabled (**LOOP** > 0) and **SEQ[1].CNT** > 0 when sequence playback starts.

6.10.4 Pin configuration

The OUT[n] (n=0..3) signals associated with each PWM channel are mapped to physical pins according to the configuration of PSEL.OUT[n] registers. If PSEL.OUT[n].CONNECT is set to Disconnected, the associated PWM module signal will not be connected to any physical pins.

The PSEL.OUT[n] registers and their configurations are used as long as the PWM module is enabled and the PWM generation active (wave counter started). They are retained only as long as the device is in System ON mode (see the **POWER** section for more information about power modes).

To ensure correct behavior in the PWM module, the pins that are used must be configured in the GPIO peripheral in the following way before the PWM module is enabled:

PWM signal	PWM pin	Direction	Output value	Comment
OUT[n]	As specified in PSEL.OUT[n] (n=0..3)	Output	0	Idle state defined in GPIO OUT register

Table 28: Recommended GPIO configuration before starting PWM generation

The idle state of a pin is defined by the OUT register in the GPIO module, to ensure that the pins used by the PWM module are driven correctly. If PWM generation is stopped by triggering a STOP task, the PWM module itself is temporarily disabled or the device temporarily enters System OFF. This configuration must be retained in the GPIO for the selected pins (I/Os) for as long as the PWM module is supposed to be connected to an external PWM circuit.

Only one peripheral can be assigned to drive a particular GPIO pin at a time. Failing to do so may result in unpredictable behavior.

6.10.5 Registers

Instances

Instance	Base address	TrustZone			Split access	Description
		Map	Att	DMA		
PWM0 : S	0x50021000	US	NS	SA	No	Pulse width modulation unit 0
PWM0 : NS	0x40021000					
PWM1 : S	0x50022000	US	NS	SA	No	Pulse width modulation unit 1
PWM1 : NS	0x40022000					
PWM2 : S	0x50023000	US	NS	SA	No	Pulse width modulation unit 2
PWM2 : NS	0x40023000					
PWM3 : S	0x50024000	US	NS	SA	No	Pulse width modulation unit 3
PWM3 : NS	0x40024000					

Register overview

Register	Offset	TZ	Description
TASKS_STOP	0x004		Stops PWM pulse generation on all channels at the end of current PWM period, and stops sequence playback
TASKS_SEQSTART[n]	0x008		Loads the first PWM value on all enabled channels from sequence n, and starts playing that sequence at the rate defined in SEQ[n]REFRESH and/or DECODER.MODE. Causes PWM generation to start if not running.
TASKS_NEXTSTEP	0x010		Steps by one value in the current sequence on all enabled channels if DECODER.MODE=NextStep. Does not cause PWM generation to start if not running.
SUBSCRIBE_STOP	0x084		Subscribe configuration for task STOP
SUBSCRIBE_SEQSTART[n]	0x088		Subscribe configuration for task SEQSTART[n]
SUBSCRIBE_NEXTSTEP	0x090		Subscribe configuration for task NEXTSTEP
EVENTS_STOPPED	0x104		Response to STOP task, emitted when PWM pulses are no longer generated
EVENTS_SEQSTARTED[n]	0x108		First PWM period started on sequence n
EVENTS_SEQEND[n]	0x110		Emitted at end of every sequence n, when last value from RAM has been applied to wave counter
EVENTS_PWMPERIODEND	0x118		Emitted at the end of each PWM period
EVENTS_LOOPSDONE	0x11C		Concatenated sequences have been played the amount of times defined in LOOP.CNT
PUBLISH_STOPPED	0x184		Publish configuration for event STOPPED
PUBLISH_SEQSTARTED[n]	0x188		Publish configuration for event SEQSTARTED[n]
PUBLISH_SEQEND[n]	0x190		Publish configuration for event SEQEND[n]
PUBLISH_PWMPERIODEND	0x198		Publish configuration for event PWMPERIODEND
PUBLISH_LOOPSDONE	0x19C		Publish configuration for event LOOPSDONE
SHORTS	0x200		Shortcuts between local events and tasks
INTEN	0x300		Enable or disable interrupt
INTENSET	0x304		Enable interrupt
INTENCLR	0x308		Disable interrupt
ENABLE	0x500		PWM module enable register
MODE	0x504		Selects operating mode of the wave counter
COUNTERTOP	0x508		Value up to which the pulse generator counter counts
PRESCALER	0x50C		Configuration for PWM_CLK
DECODER	0x510		Configuration of the decoder
LOOP	0x514		Number of playbacks of a loop
SEQ[n].PTR	0x520		Beginning address in RAM of this sequence
SEQ[n].CNT	0x524		Number of values (duty cycles) in this sequence
SEQ[n].REFRESH	0x528		Number of additional PWM periods between samples loaded into compare register
SEQ[n].ENDDELAY	0x52C		Time added after the sequence
PSEL.OUT[n]	0x560		Output pin select for PWM channel n

6.10.5.1 TASKS_STOP

Address offset: 0x004

Stops PWM pulse generation on all channels at the end of current PWM period, and stops sequence playback

Bit number	31	30	29	28	27	26	25	24	23	22	21	20	19	18	17	16	15	14	13	12	11	10	9	8	7	6	5	4	3	2	1	0
ID																																A
Reset 0x00000000	0	0	0	0	0	0	0	0	0	0	0	0	0	0	0	0	0	0	0	0	0	0	0	0	0	0	0	0	0	0	0	
ID	R/W	Field	Value ID	Value	Description																											
A	W	TASKS_STOP			Stops PWM pulse generation on all channels at the end of current PWM period, and stops sequence playback																											
			Trigger	1	Trigger task																											

6.10.5.2 TASKS_SEQSTART[n] (n=0..1)

Address offset: 0x008 + (n × 0x4)

Loads the first PWM value on all enabled channels from sequence n, and starts playing that sequence at the rate defined in SEQ[n]REFRESH and/or DECODER.MODE. Causes PWM generation to start if not running.

Bit number	31 30 29 28 27 26 25 24 23 22 21 20 19 18 17 16 15 14 13 12 11 10 9 8 7 6 5 4 3 2 1 0																														
ID	A																														
Reset	0x00000000																														
Reset	0 0																														
ID	R/W	Field	Value ID	Value	Description																										
A	W	TASKS_SEQSTART			Loads the first PWM value on all enabled channels from sequence n, and starts playing that sequence at the rate defined in SEQ[n]REFRESH and/or DECODER.MODE. Causes PWM generation to start if not running.																										
			Trigger	1	Trigger task																										

6.10.5.3 TASKS_NEXTSTEP

Address offset: 0x010

Steps by one value in the current sequence on all enabled channels if DECODER.MODE=NextStep. Does not cause PWM generation to start if not running.

Bit number	31 30 29 28 27 26 25 24 23 22 21 20 19 18 17 16 15 14 13 12 11 10 9 8 7 6 5 4 3 2 1 0																														
ID	A																														
Reset	0x00000000																														
Reset	0 0																														
ID	R/W	Field	Value ID	Value	Description																										
A	W	TASKS_NEXTSTEP			Steps by one value in the current sequence on all enabled channels if DECODER.MODE=NextStep. Does not cause PWM generation to start if not running.																										
			Trigger	1	Trigger task																										

6.10.5.4 SUBSCRIBE_STOP

Address offset: 0x084

Subscribe configuration for task STOP

Bit number	31 30 29 28 27 26 25 24 23 22 21 20 19 18 17 16 15 14 13 12 11 10 9 8 7 6 5 4 3 2 1 0																														
ID	B																														
Reset	0x00000000																														
Reset	0 0																														
ID	R/W	Field	Value ID	Value	Description																										
A	RW	CHIDX		[0..255]	DPPI channel that task STOP will subscribe to																										
B	RW	EN	Disabled	0	Disable subscription																										
			Enabled	1	Enable subscription																										

6.10.5.5 SUBSCRIBE_SEQSTART[n] (n=0..1)

Address offset: 0x088 + (n × 0x4)

Subscribe configuration for task SEQSTART[n]

Bit number	31	30	29	28	27	26	25	24	23	22	21	20	19	18	17	16	15	14	13	12	11	10	9	8	7	6	5	4	3	2	1	0
ID	B																A A A A A A A A															
Reset	0x00000000																															
Reset	0 0																															
ID	R/W	Field	Value ID	Value	Description																											
A	RW	CHIDX		[0..255]	DPPI channel that task <code>SEQSTART[n]</code> will subscribe to																											
B	RW	EN	Disabled	0	Disable subscription																											
			Enabled	1	Enable subscription																											

6.10.5.6 SUBSCRIBE_NEXTSTEP

Address offset: 0x090

Subscribe configuration for task `NEXTSTEP`

Bit number	31	30	29	28	27	26	25	24	23	22	21	20	19	18	17	16	15	14	13	12	11	10	9	8	7	6	5	4	3	2	1	0
ID	B																A A A A A A A A															
Reset	0x00000000																															
Reset	0 0																															
ID	R/W	Field	Value ID	Value	Description																											
A	RW	CHIDX		[0..255]	DPPI channel that task <code>NEXTSTEP</code> will subscribe to																											
B	RW	EN	Disabled	0	Disable subscription																											
			Enabled	1	Enable subscription																											

6.10.5.7 EVENTS_STOPPED

Address offset: 0x104

Response to STOP task, emitted when PWM pulses are no longer generated

Bit number	31	30	29	28	27	26	25	24	23	22	21	20	19	18	17	16	15	14	13	12	11	10	9	8	7	6	5	4	3	2	1	0
ID																																A
Reset	0x00000000																															
Reset	0 0																															
ID	R/W	Field	Value ID	Value	Description																											
A	RW	EVENTS_STOPPED			Response to STOP task, emitted when PWM pulses are no longer generated																											
			NotGenerated	0	Event not generated																											
			Generated	1	Event generated																											

6.10.5.8 EVENTS_SEQSTARTED[n] (n=0..1)

Address offset: 0x108 + (n × 0x4)

First PWM period started on sequence n

Bit number	31	30	29	28	27	26	25	24	23	22	21	20	19	18	17	16	15	14	13	12	11	10	9	8	7	6	5	4	3	2	1	0
ID																																A
Reset	0x00000000																															
Reset	0 0																															
ID	R/W	Field	Value ID	Value	Description																											
A	RW	EVENTS_SEQSTARTED			First PWM period started on sequence n																											
			NotGenerated	0	Event not generated																											
			Generated	1	Event generated																											

6.10.5.9 EVENTS_SEQEND[n] (n=0..1)

Address offset: 0x110 + (n × 0x4)

Emitted at end of every sequence n, when last value from RAM has been applied to wave counter

Bit number	31 30 29 28 27 26 25 24 23 22 21 20 19 18 17 16 15 14 13 12 11 10 9 8 7 6 5 4 3 2 1 0																														
ID	A																														
Reset 0x00000000	0 0																														
ID	R/W	Field	Value ID	Value	Description																										
A	RW	EVENTS_SEQEND			Emitted at end of every sequence n, when last value from RAM has been applied to wave counter																										
			NotGenerated	0	Event not generated																										
			Generated	1	Event generated																										

6.10.5.10 EVENTS_PWMPERIODEND

Address offset: 0x118

Emitted at the end of each PWM period

Bit number	31 30 29 28 27 26 25 24 23 22 21 20 19 18 17 16 15 14 13 12 11 10 9 8 7 6 5 4 3 2 1 0																														
ID	A																														
Reset 0x00000000	0 0																														
ID	R/W	Field	Value ID	Value	Description																										
A	RW	EVENTS_PWMPERIODEND			Emitted at the end of each PWM period																										
			NotGenerated	0	Event not generated																										
			Generated	1	Event generated																										

6.10.5.11 EVENTS_LOOPSDONE

Address offset: 0x11C

Concatenated sequences have been played the amount of times defined in LOOP.CNT

This event triggers after the last SEQ[1] completion of the loop, and only if looping was enabled (LOOP > 0) when the sequence playback was started.

Bit number	31 30 29 28 27 26 25 24 23 22 21 20 19 18 17 16 15 14 13 12 11 10 9 8 7 6 5 4 3 2 1 0																														
ID	A																														
Reset 0x00000000	0 0																														
ID	R/W	Field	Value ID	Value	Description																										
A	RW	EVENTS_LOOPSDONE			Concatenated sequences have been played the amount of times defined in LOOP.CNT																										
					This event triggers after the last SEQ[1] completion of the loop, and only if looping was enabled (LOOP > 0) when the sequence playback was started.																										
			NotGenerated	0	Event not generated																										
			Generated	1	Event generated																										

6.10.5.12 PUBLISH_STOPPED

Address offset: 0x184

Publish configuration for event STOPPED

Bit number	31 30 29 28 27 26 25 24 23 22 21 20 19 18 17 16 15 14 13 12 11 10 9 8 7 6 5 4 3 2 1 0																														
ID	B																								A A A A A A A						
Reset 0x00000000	0 0																														
ID	R/W	Field	Value ID	Value	Description																										
A	RW	CHIDX		[0..255]	DPPI channel that event STOPPED will publish to																										
B	RW	EN	Disabled	0	Disable publishing																										
			Enabled	1	Enable publishing																										

6.10.5.13 PUBLISH_SEQSTARTED[n] (n=0..1)

Address offset: 0x188 + (n × 0x4)

Publish configuration for event SEQSTARTED[n]

Bit number	31 30 29 28 27 26 25 24 23 22 21 20 19 18 17 16 15 14 13 12 11 10 9 8 7 6 5 4 3 2 1 0																														
ID	B																								A A A A A A A						
Reset 0x00000000	0 0																														
ID	R/W	Field	Value ID	Value	Description																										
A	RW	CHIDX		[0..255]	DPPI channel that event SEQSTARTED[n] will publish to																										
B	RW	EN	Disabled	0	Disable publishing																										
			Enabled	1	Enable publishing																										

6.10.5.14 PUBLISH_SEQEND[n] (n=0..1)

Address offset: 0x190 + (n × 0x4)

Publish configuration for event SEQEND[n]

Bit number	31 30 29 28 27 26 25 24 23 22 21 20 19 18 17 16 15 14 13 12 11 10 9 8 7 6 5 4 3 2 1 0																														
ID	B																								A A A A A A A						
Reset 0x00000000	0 0																														
ID	R/W	Field	Value ID	Value	Description																										
A	RW	CHIDX		[0..255]	DPPI channel that event SEQEND[n] will publish to																										
B	RW	EN	Disabled	0	Disable publishing																										
			Enabled	1	Enable publishing																										

6.10.5.15 PUBLISH_PWMPERIODEND

Address offset: 0x198

Publish configuration for event PWMPERIODEND

Bit number	31 30 29 28 27 26 25 24 23 22 21 20 19 18 17 16 15 14 13 12 11 10 9 8 7 6 5 4 3 2 1 0																														
ID	B																								A A A A A A A						
Reset 0x00000000	0 0																														
ID	R/W	Field	Value ID	Value	Description																										
A	RW	CHIDX		[0..255]	DPPI channel that event PWMPERIODEND will publish to																										
B	RW	EN	Disabled	0	Disable publishing																										
			Enabled	1	Enable publishing																										

6.10.5.16 PUBLISH_LOOPSDONE

Address offset: 0x19C

Publish configuration for event [LOOPSDONE](#)

This event triggers after the last SEQ[1] completion of the loop, and only if looping was enabled (LOOP > 0) when the sequence playback was started.

Bit number	31	30	29	28	27	26	25	24	23	22	21	20	19	18	17	16	15	14	13	12	11	10	9	8	7	6	5	4	3	2	1	0
ID	B																A A A A A A A A															
Reset 0x00000000	0 0																															
ID	R/W	Field	Value ID	Value	Description																											
A	RW	CHIDX		[0..255]	DPPI channel that event LOOPSDONE will publish to																											
B	RW	EN	Disabled	0	Disable publishing																											
			Enabled	1	Enable publishing																											

6.10.5.17 SHORTS

Address offset: 0x200

Shortcuts between local events and tasks

Bit number	31	30	29	28	27	26	25	24	23	22	21	20	19	18	17	16	15	14	13	12	11	10	9	8	7	6	5	4	3	2	1	0				
ID																									E D C B A											
Reset 0x00000000	0 0																																			
ID	R/W	Field	Value ID	Value	Description																															
A	RW	SEQEND0_STOP	Disabled	0	Shortcut between event SEQEND[0] and task STOP Disable shortcut																															
			Enabled	1	Enable shortcut																															
B	RW	SEQEND1_STOP	Disabled	0	Shortcut between event SEQEND[1] and task STOP Disable shortcut																															
			Enabled	1	Enable shortcut																															
C	RW	LOOPSDONE_SEQSTART0	Disabled	0	Shortcut between event LOOPSDONE and task SEQSTART[0] Disable shortcut																															
			Enabled	1	Enable shortcut																															
D	RW	LOOPSDONE_SEQSTART1	Disabled	0	Shortcut between event LOOPSDONE and task SEQSTART[1] Disable shortcut																															
			Enabled	1	Enable shortcut																															
E	RW	LOOPSDONE_STOP	Disabled	0	Shortcut between event LOOPSDONE and task STOP Disable shortcut																															
			Enabled	1	Enable shortcut																															

6.10.5.18 INTEN

Address offset: 0x300

Enable or disable interrupt

Bit number	31	30	29	28	27	26	25	24	23	22	21	20	19	18	17	16	15	14	13	12	11	10	9	8	7	6	5	4	3	2	1	0
ID																									H G F E D C B							
Reset 0x00000000	0 0																															
ID	R/W	Field	Value ID	Value	Description																											
B	RW	STOPPED			Enable or disable interrupt for event STOPPED																											

Bit number		31 30 29 28 27 26 25 24 23 22 21 20 19 18 17 16 15 14 13 12 11 10 9 8 7 6 5 4 3 2 1 0																																		
ID																														H	G	F	E	D	C	B
Reset 0x00000000		0 0																																		
ID	R/W	Field	Value ID	Value	Description																															
			Disabled	0	Disable																															
			Enabled	1	Enable																															
C-D	RW	SEQSTARTED[i] (i=0..1)			Enable or disable interrupt for event SEQSTARTED[i]																															
			Disabled	0	Disable																															
			Enabled	1	Enable																															
E-F	RW	SEQEND[i] (i=0..1)			Enable or disable interrupt for event SEQEND[i]																															
			Disabled	0	Disable																															
			Enabled	1	Enable																															
G	RW	PWMPERIODEND			Enable or disable interrupt for event PWMPERIODEND																															
			Disabled	0	Disable																															
			Enabled	1	Enable																															
H	RW	LOOPSDONE			Enable or disable interrupt for event LOOPSDONE																															
					This event triggers after the last SEQ[1] completion of the loop, and only if looping was enabled (LOOP > 0) when the sequence playback was started.																															
			Disabled	0	Disable																															
			Enabled	1	Enable																															

6.10.5.19 INTENSET

Address offset: 0x304

Enable interrupt

Bit number		31 30 29 28 27 26 25 24 23 22 21 20 19 18 17 16 15 14 13 12 11 10 9 8 7 6 5 4 3 2 1 0																																		
ID																														H	G	F	E	D	C	B
Reset 0x00000000		0 0																																		
ID	R/W	Field	Value ID	Value	Description																															
B	RW	STOPPED			Write '1' to enable interrupt for event STOPPED																															
			Set	1	Enable																															
			Disabled	0	Read: Disabled																															
			Enabled	1	Read: Enabled																															
C-D	RW	SEQSTARTED[i] (i=0..1)			Write '1' to enable interrupt for event SEQSTARTED[i]																															
			Set	1	Enable																															
			Disabled	0	Read: Disabled																															
			Enabled	1	Read: Enabled																															
E-F	RW	SEQEND[i] (i=0..1)			Write '1' to enable interrupt for event SEQEND[i]																															
			Set	1	Enable																															
			Disabled	0	Read: Disabled																															
			Enabled	1	Read: Enabled																															
G	RW	PWMPERIODEND			Write '1' to enable interrupt for event PWMPERIODEND																															
			Set	1	Enable																															
			Disabled	0	Read: Disabled																															
			Enabled	1	Read: Enabled																															
H	RW	LOOPSDONE			Write '1' to enable interrupt for event LOOPSDONE																															
					This event triggers after the last SEQ[1] completion of the loop, and only if looping was enabled (LOOP > 0) when the sequence playback was started.																															
			Set	1	Enable																															
			Disabled	0	Read: Disabled																															
			Enabled	1	Read: Enabled																															

6.10.5.20 INTENCLR

Address offset: 0x308

Disable interrupt

Bit number	31 30 29 28 27 26 25 24 23 22 21 20 19 18 17 16 15 14 13 12 11 10 9 8 7 6 5 4 3 2 1 0																																				
ID																															H	G	F	E	D	C	B
Reset 0x00000000	0 0																																				
ID	R/W	Field	Value ID	Value	Description																																
B	RW	STOPPED			Write '1' to disable interrupt for event STOPPED																																
			Clear	1	Disable																																
			Disabled	0	Read: Disabled																																
			Enabled	1	Read: Enabled																																
C-D	RW	SEQSTARTED[i] (i=0..1)			Write '1' to disable interrupt for event SEQSTARTED[i]																																
			Clear	1	Disable																																
			Disabled	0	Read: Disabled																																
			Enabled	1	Read: Enabled																																
E-F	RW	SEQEND[i] (i=0..1)			Write '1' to disable interrupt for event SEQEND[i]																																
			Clear	1	Disable																																
			Disabled	0	Read: Disabled																																
			Enabled	1	Read: Enabled																																
G	RW	PWMPERIODEND			Write '1' to disable interrupt for event PWMPERIODEND																																
			Clear	1	Disable																																
			Disabled	0	Read: Disabled																																
			Enabled	1	Read: Enabled																																
H	RW	LOOPSDONE			Write '1' to disable interrupt for event LOOPSDONE																																
					This event triggers after the last SEQ[1] completion of the loop, and only if looping was enabled (LOOP > 0) when the sequence playback was started.																																
			Clear	1	Disable																																
			Disabled	0	Read: Disabled																																
	Enabled	1	Read: Enabled																																		

6.10.5.21 ENABLE

Address offset: 0x500

PWM module enable register

Bit number	31 30 29 28 27 26 25 24 23 22 21 20 19 18 17 16 15 14 13 12 11 10 9 8 7 6 5 4 3 2 1 0																														
ID																															A
Reset 0x00000000	0 0																														
ID	R/W	Field	Value ID	Value	Description																										
A	RW	ENABLE			Enable or disable PWM module																										
			Disabled	0	Disabled																										
			Enabled	1	Enable																										

6.10.5.22 MODE

Address offset: 0x504

Selects operating mode of the wave counter

Bit number	31	30	29	28	27	26	25	24	23	22	21	20	19	18	17	16	15	14	13	12	11	10	9	8	7	6	5	4	3	2	1	0
ID																																A
Reset	0x00000000																															
Reset	0	0	0	0	0	0	0	0	0	0	0	0	0	0	0	0	0	0	0	0	0	0	0	0	0	0	0	0	0	0	0	0
ID	R/W	Field	Value ID	Value	Description																											
A	RW	UPDOWN			Selects up mode or up-and-down mode for the counter																											
			Up	0	Up counter, edge-aligned PWM duty cycle																											
			UpAndDown	1	Up and down counter, center-aligned PWM duty cycle																											

6.10.5.23 COUNTERTOP

Address offset: 0x508

Value up to which the pulse generator counter counts

Bit number	31	30	29	28	27	26	25	24	23	22	21	20	19	18	17	16	15	14	13	12	11	10	9	8	7	6	5	4	3	2	1	0																								
ID																													A	A	A	A	A	A	A	A	A	A	A	A	A	A	A	A	A	A	A	A	A	A	A	A	A	A	A	A
Reset	0x000003FF																																																							
Reset	0	0	0	0	0	0	0	0	0	0	0	0	0	0	0	0	0	0	0	0	0	0	0	0	1	1	1	1	1	1	1	1																								
ID	R/W	Field	Value ID	Value	Description																																																			
A	RW	COUNTERTOP		[3..32767]	Value up to which the pulse generator counter counts. This register is ignored when DECODER.MODE=WaveForm and only values from RAM are used.																																																			

6.10.5.24 PRESCALER

Address offset: 0x50C

Configuration for PWM_CLK

Bit number	31	30	29	28	27	26	25	24	23	22	21	20	19	18	17	16	15	14	13	12	11	10	9	8	7	6	5	4	3	2	1	0
ID																													A	A	A	
Reset	0x00000000																															
Reset	0	0	0	0	0	0	0	0	0	0	0	0	0	0	0	0	0	0	0	0	0	0	0	0	0	0	0	0	0	0	0	
ID	R/W	Field	Value ID	Value	Description																											
A	RW	PRESCALER			Prescaler of PWM_CLK																											
			DIV_1	0	Divide by 1 (16 MHz)																											
			DIV_2	1	Divide by 2 (8 MHz)																											
			DIV_4	2	Divide by 4 (4 MHz)																											
			DIV_8	3	Divide by 8 (2 MHz)																											
			DIV_16	4	Divide by 16 (1 MHz)																											
			DIV_32	5	Divide by 32 (500 kHz)																											
			DIV_64	6	Divide by 64 (250 kHz)																											
			DIV_128	7	Divide by 128 (125 kHz)																											

6.10.5.25 DECODER

Address offset: 0x510

Configuration of the decoder

Bit number	31 30 29 28 27 26 25 24 23 22 21 20 19 18 17 16 15 14 13 12 11 10 9 8 7 6 5 4 3 2 1 0																																	
ID																												B				A		A
Reset 0x00000000	0 0																																	
ID	R/W	Field	Value ID	Value	Description																													
A	RW	LOAD	Common	0	How a sequence is read from RAM and spread to the compare register 1st half word (16-bit) used in all PWM channels 0..3																													
			Grouped	1	1st half word (16-bit) used in channel 0..1; 2nd word in channel 2..3																													
			Individual	2	1st half word (16-bit) in ch.0; 2nd in ch.1; ...; 4th in ch.3																													
			WaveForm	3	1st half word (16-bit) in ch.0; 2nd in ch.1; ...; 4th in COUNTERTOP																													
B	RW	MODE	RefreshCount	0	Selects source for advancing the active sequence SEQ[n].REFRESH is used to determine loading internal compare registers																													
			NextStep	1	NEXTSTEP task causes a new value to be loaded to internal compare registers																													

6.10.5.26 LOOP

Address offset: 0x514

Number of playbacks of a loop

Bit number	31 30 29 28 27 26 25 24 23 22 21 20 19 18 17 16 15 14 13 12 11 10 9 8 7 6 5 4 3 2 1 0																																																					
ID																												A				A	A	A	A	A	A	A	A	A	A	A	A	A	A	A	A	A	A	A	A	A	A	A
Reset 0x00000000	0 0																																																					
ID	R/W	Field	Value ID	Value	Description																																																	
A	RW	CNT	Disabled	0	Number of playbacks of pattern cycles Looping disabled (stop at the end of the sequence)																																																	

6.10.5.27 SEQ[n].PTR (n=0..1)

Address offset: 0x520 + (n × 0x20)

Beginning address in RAM of this sequence

Bit number	31 30 29 28 27 26 25 24 23 22 21 20 19 18 17 16 15 14 13 12 11 10 9 8 7 6 5 4 3 2 1 0																																																						
ID	A																											A	A	A	A	A	A	A	A	A	A	A	A	A	A	A	A	A	A	A	A	A	A	A	A	A	A	A	A
Reset 0x00000000	0 0																																																						
ID	R/W	Field	Value ID	Value	Description																																																		
A	RW	PTR			Beginning address in RAM of this sequence																																																		

Note: See the memory chapter for details about which memories are available for EasyDMA.

6.10.5.28 SEQ[n].CNT (n=0..1)

Address offset: 0x524 + (n × 0x20)

Number of values (duty cycles) in this sequence

Bit number	31 30 29 28 27 26 25 24 23 22 21 20 19 18 17 16 15 14 13 12 11 10 9 8 7 6 5 4 3 2 1 0																																																					
ID																												A				A	A	A	A	A	A	A	A	A	A	A	A	A	A	A	A	A	A	A	A	A	A	A
Reset 0x00000000	0 0																																																					
ID	R/W	Field	Value ID	Value	Description																																																	
A	RW	CNT	Disabled	0	Number of values (duty cycles) in this sequence Sequence is disabled, and shall not be started as it is empty																																																	

6.10.5.29 SEQ[n].REFRESH (n=0..1)

Address offset: $0x528 + (n \times 0x20)$

Number of additional PWM periods between samples loaded into compare register

Bit number	31 30 29 28 27 26 25 24 23 22 21 20 19 18 17 16 15 14 13 12 11 10 9 8 7 6 5 4 3 2 1 0																														
ID	A A																														
Reset 0x00000001	0 1																														
ID	R/W	Field	Value ID	Value	Description																										
A	RW	CNT			Number of additional PWM periods between samples loaded into compare register (load every REFRESH.CNT+1 PWM periods)																										
			Continuous	0	Update every PWM period																										

6.10.5.30 SEQ[n].ENDDELAY (n=0..1)

Address offset: $0x52C + (n \times 0x20)$

Time added after the sequence

Bit number	31 30 29 28 27 26 25 24 23 22 21 20 19 18 17 16 15 14 13 12 11 10 9 8 7 6 5 4 3 2 1 0																														
ID	A A																														
Reset 0x00000000	0 0																														
ID	R/W	Field	Value ID	Value	Description																										
A	RW	CNT			Time added after the sequence in PWM periods																										

6.10.5.31 PSEL.OUT[n] (n=0..3)

Address offset: $0x560 + (n \times 0x4)$

Output pin select for PWM channel n

Bit number	31 30 29 28 27 26 25 24 23 22 21 20 19 18 17 16 15 14 13 12 11 10 9 8 7 6 5 4 3 2 1 0																														
ID	B A A A A A																														
Reset 0xFFFFFFFF	1 1																														
ID	R/W	Field	Value ID	Value	Description																										
A	RW	PIN		[0..31]	Pin number																										
B	RW	CONNECT			Connection																										
			Disconnected	1	Disconnect																										
			Connected	0	Connect																										

6.11 RTC — Real-time counter

The real-time counter (RTC) module provides a generic, low-power timer on the low frequency clock source (LFCLK).

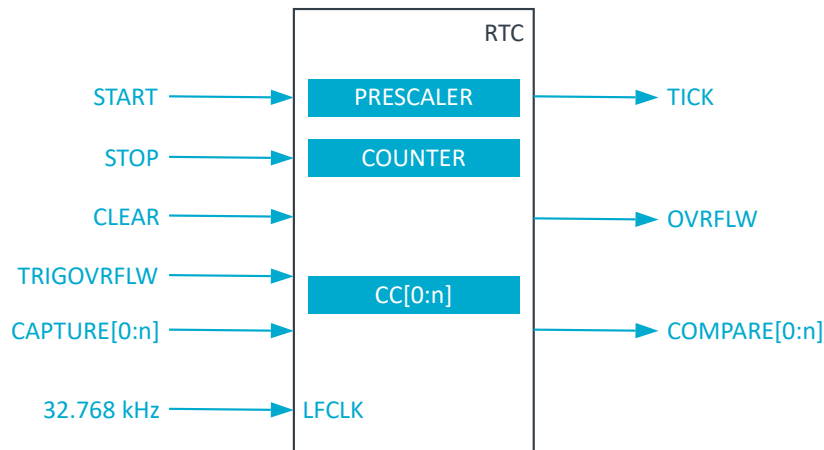

Figure 56: RTC block diagram

The RTC module features a 24-bit COUNTER, a 12-bit (1/X) prescaler, compare registers, and a tick event generator.

6.11.1 Clock source

The RTC will run off the LFCLK.

When started, the RTC will automatically request the LFCLK source with RC oscillator if the LFCLK is not already running.

See [CLOCK — Clock control](#) on page 75 for more information about clock sources.

6.11.2 Resolution versus overflow and the prescaler

The relationship between the prescaler, counter resolution, and overflow is summarized in the following table.

Prescaler	Counter resolution	Overflow
0	30.517 μ s	512 seconds
2^8-1	7812.5 μ s	131072 seconds
$2^{12}-1$	125 ms	582.542 hours

Table 29: RTC resolution versus overflow

The counter increment frequency is given by the following equation:

$$f_{\text{RTC}} [\text{kHz}] = 32.768 / (\text{PRESCALER} + 1)$$

The **PRESCALER** register can only be written when the RTC is stopped.

The prescaler is restarted on tasks **START**, **CLEAR** and **TRIGOVFLW**. That is, the prescaler value is latched to an internal register (<<PRESC>>) on these tasks.

Examples:

1. Desired COUNTER frequency 100 Hz (10 ms counter period)

$$\text{PRESCALER} = \text{round}(32.768 \text{ kHz} / 100 \text{ Hz}) - 1 = 327$$

$$f_{\text{RTC}} = 99.9 \text{ Hz}$$

$$10009.576 \mu\text{s counter period}$$

2. Desired COUNTER frequency 8 Hz (125 ms counter period)

$$\text{PRESCALER} = \text{round}(32.768 \text{ kHz} / 8 \text{ Hz}) - 1 = 4095$$

$$f_{\text{RTC}} = 8 \text{ Hz}$$

125 ms counter period

6.11.3 Counter register

The internal <<COUNTER>> register increments on LFCLK when the internal PRESCALER register (<<PRESC>>) is 0x00. <<PRESC>> is reloaded from the PRESCALER register. If enabled, the TICK event occurs on each increment of the COUNTER.

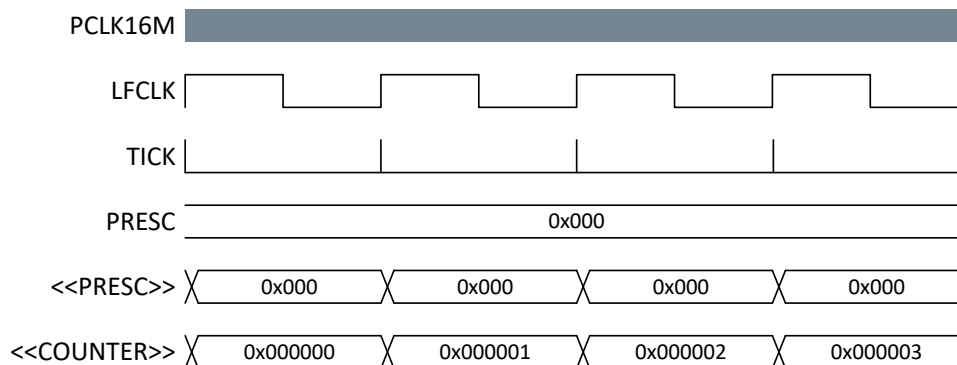

Figure 57: Timing diagram - COUNTER_PRESCALER_0

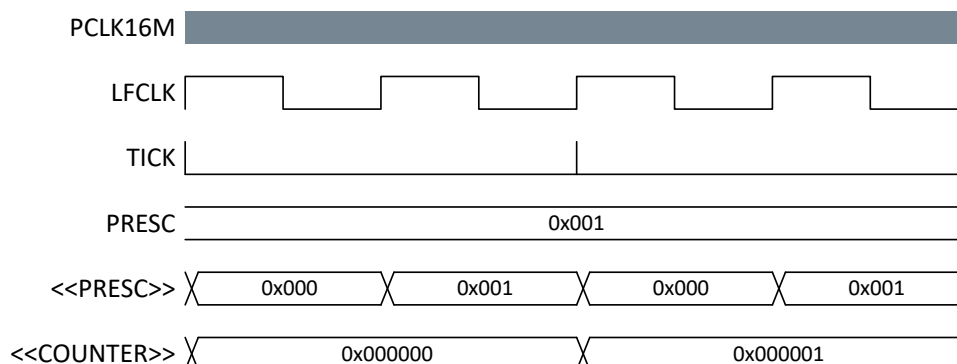

Figure 58: Timing diagram - COUNTER_PRESCALER_1

6.11.3.1 Reading the counter register

To read the COUNTER register, the internal <<COUNTER>> value is sampled.

To ensure that the <<COUNTER>> is safely sampled (considering that an LFCLK transition may occur during a read), the CPU and core memory bus are halted for PCLK16M cycles. In addition, the read takes the CPU two PCLK16M cycles, resulting in the COUNTER register read taking maximum six PCLK16M clock cycles.

6.11.4 Overflow

An OVRFLW event is generated on COUNTER register overflow (overflowing from 0xFFFFF to 0).

The TRIGOVRFLW task will set the COUNTER value to 0xFFFFF0, to allow software test of the overflow condition.

Note: The OVRFLW event is disabled by default.

6.11.5 Tick event

The **TICK** event enables low-power tickless RTOS implementation, as it optionally provides a regular interrupt source for an RTOS with no need for use of the ARM SysTick feature.

Using the **TICK** event, rather than the SysTick, allows the CPU to be powered down while keeping RTOS scheduling active.

Note: The **TICK** event is disabled by default.

6.11.6 Event control

To optimize the RTC power consumption, events in the RTC can be individually disabled to prevent PCLK16M and HFCLK from being requested when those events are triggered. This is managed using the **EVTEN** register.

This means that the RTC implements a slightly different task and event system compared to the standard system described in [Peripheral interface](#) on page 17. The RTC task and event system is illustrated in the following figure.

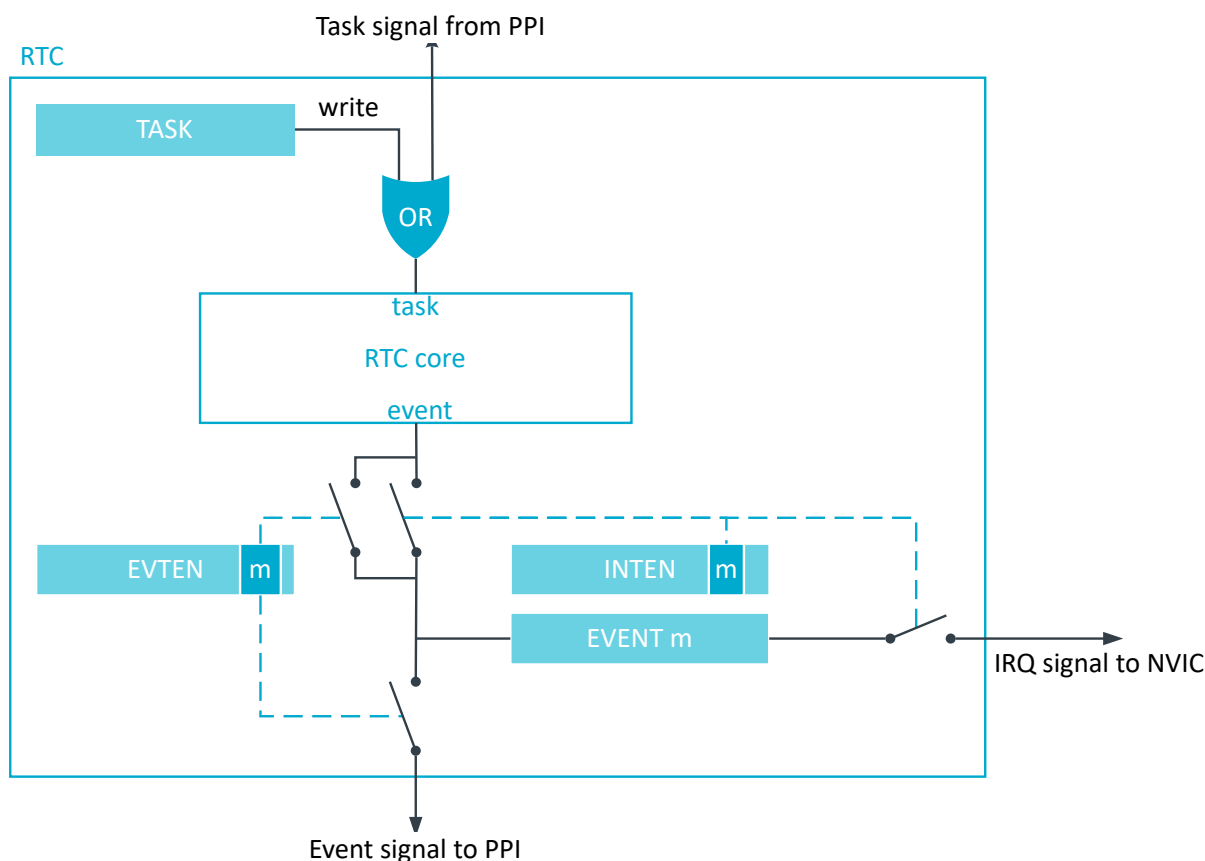

Figure 59: Tasks, events, and interrupts in the RTC

6.11.7 Compare

The RTC implements one **COMPARE** event for every available compare register.

When the **COUNTER** is incremented and then becomes equal to the value specified in the register **CC[n]**, the corresponding compare event **COMPARE[n]** is generated.

When writing a **CC[n]** register, the **RTC COMPARE** event exhibits several behaviors. See the following figures for more information.

If a **CC** value is 0 when a **CLEAR** task is set, this will not trigger a **COMPARE** event.

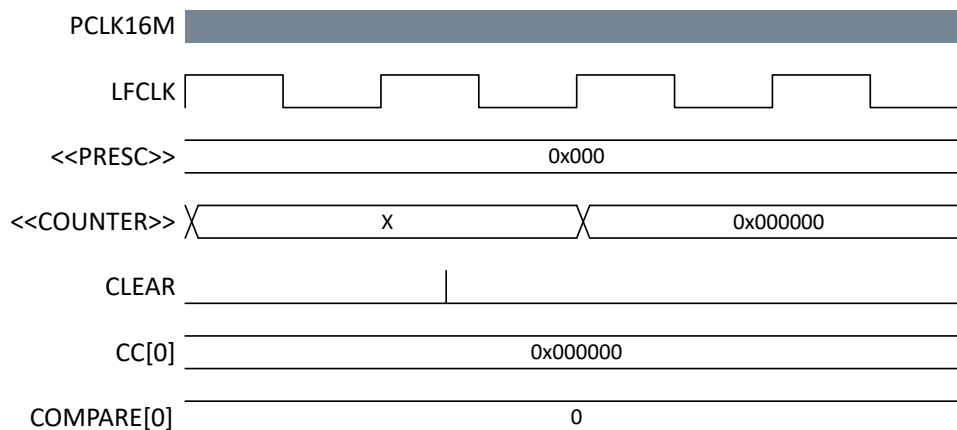

Figure 60: Timing diagram - COMPARE_CLEAR

If a **CC** value is **N** and the **COUNTER** value is **N** when the **START** task is set, this will not trigger a **COMPARE** event.

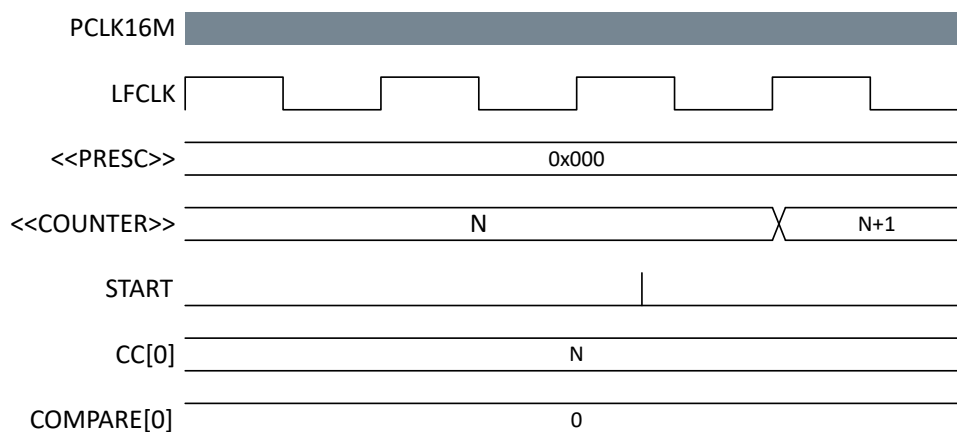

Figure 61: Timing diagram - COMPARE_START

A **COMPARE** event occurs when a **CC** value is **N**, and the **COUNTER** value transitions from **N-1** to **N**.

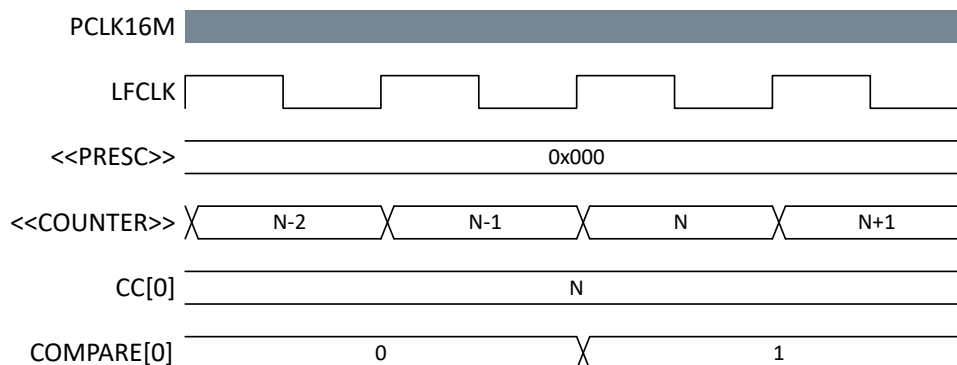

Figure 62: Timing diagram - COMPARE

If the **COUNTER** value is **N**, writing **N+2** to a **CC** register is guaranteed to trigger a **COMPARE** event at **N+2**.

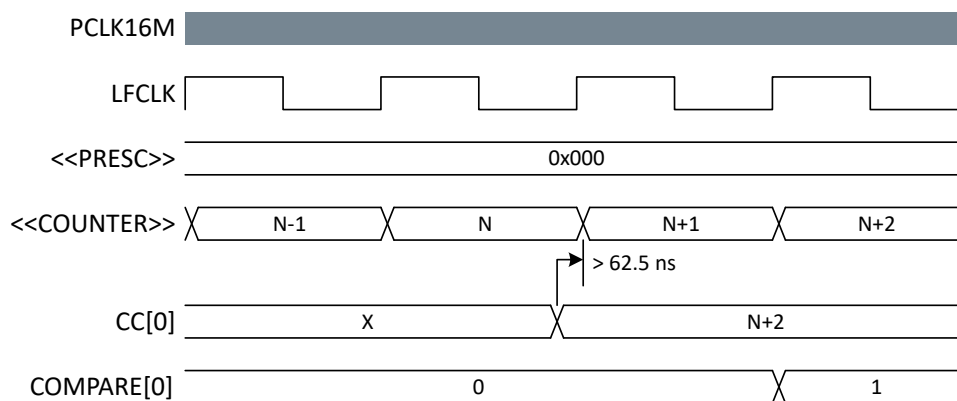

Figure 63: Timing diagram - COMPARE_N+2

If the **COUNTER** value is N, writing N or N+1 to a **CC** register may not trigger a **COMPARE** event.

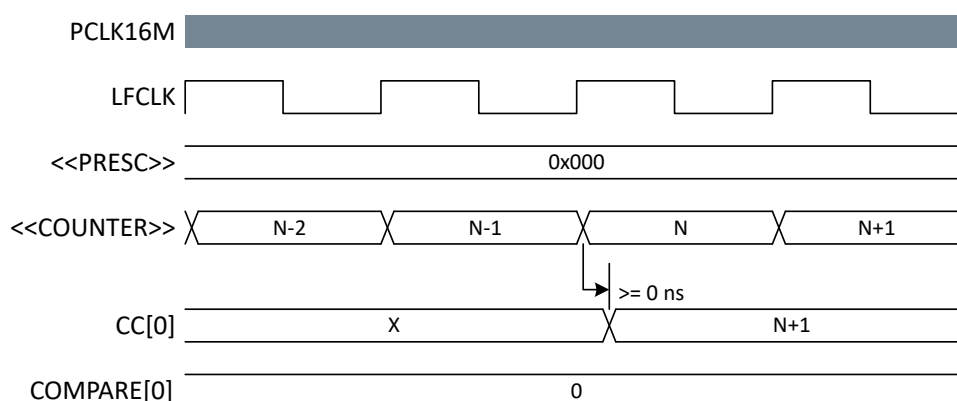

Figure 64: Timing diagram - COMPARE_N+1

If the **COUNTER** value is N, and the current **CC** value is N+1 or N+2 when a new **CC** value is written, a match may trigger on the previous **CC** value before the new value takes effect. If the current **CC** value is greater than N+2 when the new value is written, there will be no event due to the old value.

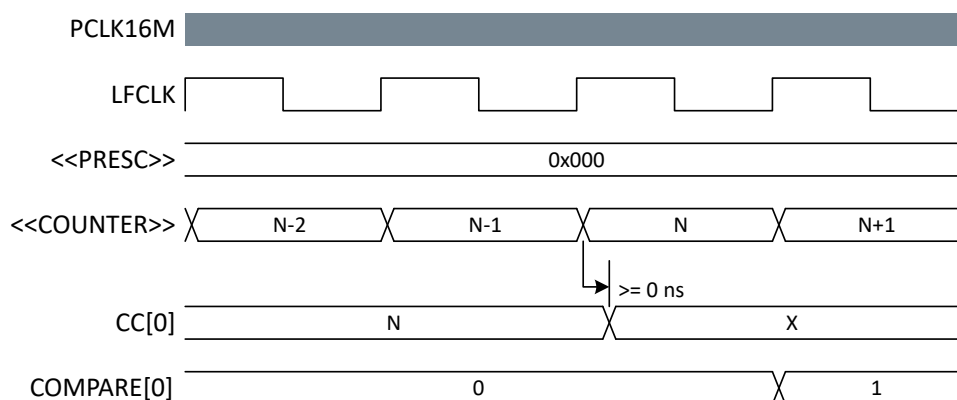

Figure 65: Timing diagram - COMPARE_N-1

6.11.8 Task and event jitter/delay

Jitter or delay in the RTC is due to the peripheral clock being a low frequency clock (LFCLK), which is not synchronous to the faster PCLK16M.

Registers in the peripheral interface that are part of the PCLK16M domain, have a set of mirrored registers in the LFCLK domain. For example, the **COUNTER** value accessible from the CPU is in the PCLK16M domain and is latched on a read from an internal **COUNTER** register in the LFCLK domain. The **COUNTER** register

is modified each time the RTC ticks. The registers are synchronised between the two clock domains (PCLK16M and LFCLK).

CLEAR and **STOP** (and **TRIGOVFLW**, which is not shown) will be delayed as long as it takes for the peripheral to clock a falling edge and a rising edge of the LFCLK. This is between 15.2585 μs and 45.7755 μs – rounded to 15 μs and 46 μs for the remainder of the section.

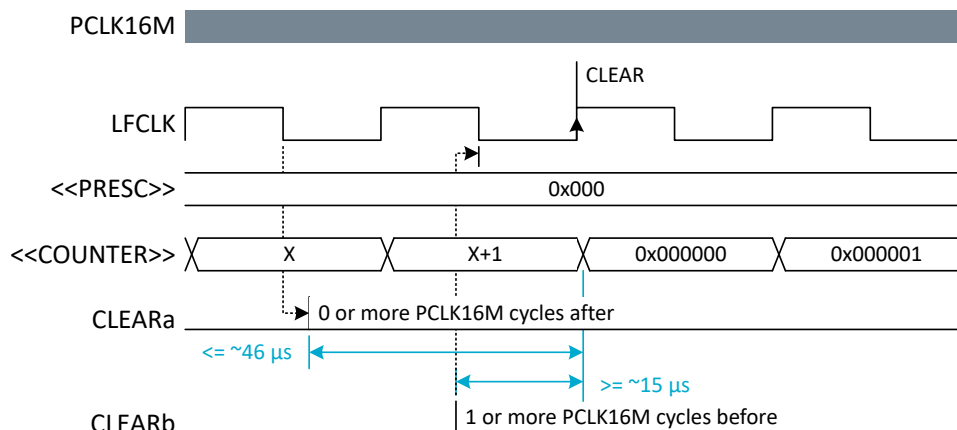

Figure 66: Timing diagram - DELAY_CLEAR

When a **STOP** task is triggered, the PCLK16M domain will immediately prevent the generation of any EVENTS from the RTC. However, as seen in the following figure, the **COUNTER** value can still increment one final time.

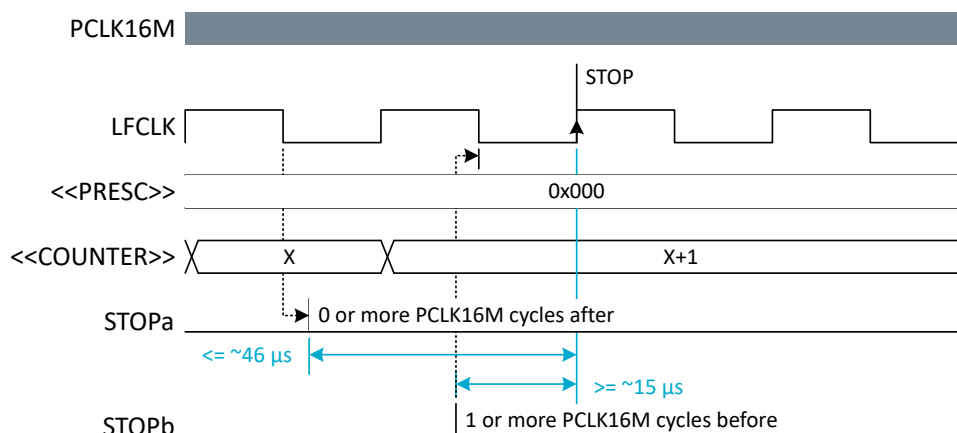

Figure 67: Timing diagram - DELAY_STOP

The **START** task will start the RTC. Assuming that the LFCLK was previously running and stable, the first increment of **COUNTER** (and instance of TICK event) will be typically after 30.5 μs +/- 15 μs . Additional delay will occur if the RTC is started before the LFCLK is running, see **CLOCK — Clock control** on page 75 for LFLK startup times. The software should therefore wait for the first TICK if it has to make sure that the RTC is running. Sending a **TRIGOVFLW** task sets the **COUNTER** to a value close to overflow. However, since the update of **COUNTER** relies on a stable LFCLK, sending this task while LFCLK is not running will also add additional delay as previously described. The figures show the smallest and largest delays on the **START** task, appearing as a +/- 15 μs jitter on the first **COUNTER** increment.

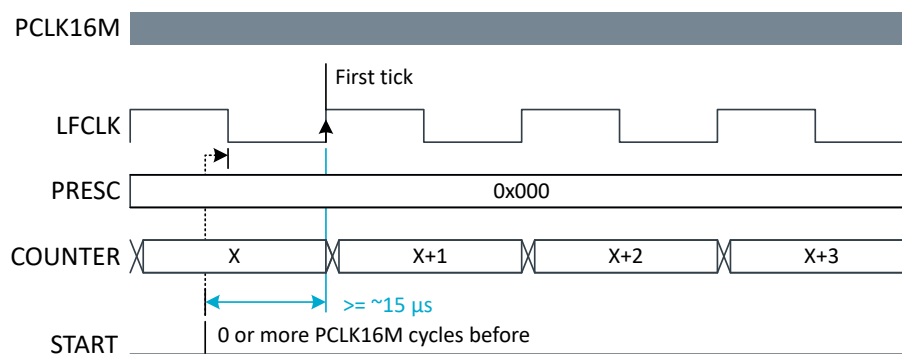

Figure 68: Timing diagram - JITTER_START-

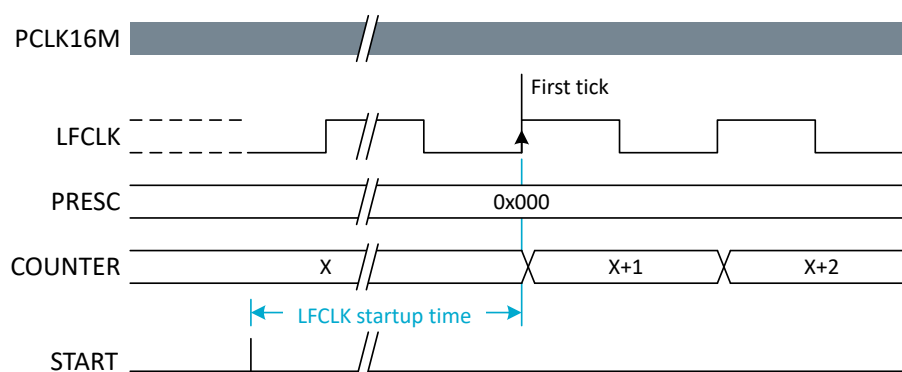

Figure 69: Timing diagram - JITTER_START+

The following tables summarize jitter introduced for tasks and events. Any 32.768 kHz clock jitter will come in addition to these numbers.

Task	Delay
CLEAR, START, STOP, TRIGOVRFLOW	+15 to 46 μs

Table 30: RTC jitter magnitudes on tasks

Operation/Function	Jitter
START to COUNTER increment	$\pm 15 \mu\text{s}$
COMPARE to COMPARE ¹³	$\pm 62.5 \text{ ns}$

Table 31: RTC jitter magnitudes on events

6.11.9 Registers

Instances

Instance	Base address	TrustZone			Split access	Description
		Map	Att	DMA		
RTC0 : S	0x50014000	US	NS	NA	No	Real time counter 0
RTC0 : NS	0x40014000	US	NS	NA	No	Real time counter 0
RTC1 : S	0x50015000	US	NS	NA	No	Real time counter 1
RTC1 : NS	0x40015000	US	NS	NA	No	Real time counter 1

¹³ Assumes RTC runs continuously between these events.

Register overview

Register	Offset	TZ	Description
TASKS_START	0x000		Start RTC counter
TASKS_STOP	0x004		Stop RTC counter
TASKS_CLEAR	0x008		Clear RTC counter
TASKS_TRIGOVFLW	0x00C		Set counter to 0xFFFFF0
SUBSCRIBE_START	0x080		Subscribe configuration for task START
SUBSCRIBE_STOP	0x084		Subscribe configuration for task STOP
SUBSCRIBE_CLEAR	0x088		Subscribe configuration for task CLEAR
SUBSCRIBE_TRIGOVFLW	0x08C		Subscribe configuration for task TRIGOVFLW
EVENTS_TICK	0x100		Event on counter increment
EVENTS_OVRFLW	0x104		Event on counter overflow
EVENTS_COMPARE[n]	0x140		Compare event on CC[n] match
PUBLISH_TICK	0x180		Publish configuration for event TICK
PUBLISH_OVRFLW	0x184		Publish configuration for event OVRFLW
PUBLISH_COMPARE[n]	0x1C0		Publish configuration for event COMPARE[n]
INTENSET	0x304		Enable interrupt
INTENCLR	0x308		Disable interrupt
EVTEN	0x340		Enable or disable event routing
EVTENSET	0x344		Enable event routing
EVTENCLR	0x348		Disable event routing
COUNTER	0x504		Current counter value
PRESCALER	0x508		12-bit prescaler for counter frequency (32768/(PRESCALER+1)). Must be written when RTC is stopped.
CC[n]	0x540		Compare register n

6.11.9.1 TASKS_START

Address offset: 0x000

Start RTC counter

Bit number	31	30	29	28	27	26	25	24	23	22	21	20	19	18	17	16	15	14	13	12	11	10	9	8	7	6	5	4	3	2	1	0
ID																																A
Reset 0x00000000	0 0																															
ID	R/W	Field	Value ID	Value	Description																											
A	W	TASKS_START	Trigger	1	Start RTC counter Trigger task																											

6.11.9.2 TASKS_STOP

Address offset: 0x004

Stop RTC counter

Bit number	31	30	29	28	27	26	25	24	23	22	21	20	19	18	17	16	15	14	13	12	11	10	9	8	7	6	5	4	3	2	1	0
ID																																A
Reset 0x00000000	0 0																															
ID	R/W	Field	Value ID	Value	Description																											
A	W	TASKS_STOP	Trigger	1	Stop RTC counter Trigger task																											

6.11.9.3 TASKS_CLEAR

Address offset: 0x008

Clear RTC counter

Bit number	31 30 29 28 27 26 25 24 23 22 21 20 19 18 17 16 15 14 13 12 11 10 9 8 7 6 5 4 3 2 1 0																														
ID	A																														
Reset 0x00000000	0 0																														
ID	R/W	Field	Value ID	Value	Description																										
A	W	TASKS_CLEAR			Clear RTC counter																										
			Trigger	1	Trigger task																										

6.11.9.4 TASKS_TRIGOVFLW

Address offset: 0x00C

Set counter to 0xFFFFF0

Bit number	31 30 29 28 27 26 25 24 23 22 21 20 19 18 17 16 15 14 13 12 11 10 9 8 7 6 5 4 3 2 1 0																														
ID	A																														
Reset 0x00000000	0 0																														
ID	R/W	Field	Value ID	Value	Description																										
A	W	TASKS_TRIGOVFLW			Set counter to 0xFFFFF0																										
			Trigger	1	Trigger task																										

6.11.9.5 SUBSCRIBE_START

Address offset: 0x080

Subscribe configuration for task **START**

Bit number	31 30 29 28 27 26 25 24 23 22 21 20 19 18 17 16 15 14 13 12 11 10 9 8 7 6 5 4 3 2 1 0																																										
ID	B																											A				A				A				A			
Reset 0x00000000	0 0																																										
ID	R/W	Field	Value ID	Value	Description																																						
A	RW	CHIDX		[0..255]	DPPI channel that task START will subscribe to																																						
B	RW	EN	Disabled	0	Disable subscription																																						
			Enabled	1	Enable subscription																																						

6.11.9.6 SUBSCRIBE_STOP

Address offset: 0x084

Subscribe configuration for task **STOP**

Bit number	31 30 29 28 27 26 25 24 23 22 21 20 19 18 17 16 15 14 13 12 11 10 9 8 7 6 5 4 3 2 1 0																																						
ID	B																											A				A				A			
Reset 0x00000000	0 0																																						
ID	R/W	Field	Value ID	Value	Description																																		
A	RW	CHIDX		[0..255]	DPPI channel that task STOP will subscribe to																																		
B	RW	EN	Disabled	0	Disable subscription																																		
			Enabled	1	Enable subscription																																		

6.11.9.7 SUBSCRIBE_CLEAR

Address offset: 0x088

Subscribe configuration for task CLEAR

Bit number	31 30 29 28 27 26 25 24 23 22 21 20 19 18 17 16 15 14 13 12 11 10 9 8 7 6 5 4 3 2 1 0																														
ID	B																												A A A A A A A A		
Reset 0x00000000	0 0																														
ID	R/W	Field	Value ID	Value	Description																										
A	RW	CHIDX		[0..255]	DPPI channel that task CLEAR will subscribe to																										
B	RW	EN	Disabled	0	Disable subscription																										
			Enabled	1	Enable subscription																										

6.11.9.8 SUBSCRIBE_TRIGOVFLW

Address offset: 0x08C

Subscribe configuration for task TRIGOVFLW

Bit number	31 30 29 28 27 26 25 24 23 22 21 20 19 18 17 16 15 14 13 12 11 10 9 8 7 6 5 4 3 2 1 0																														
ID	B																												A A A A A A A A		
Reset 0x00000000	0 0																														
ID	R/W	Field	Value ID	Value	Description																										
A	RW	CHIDX		[0..255]	DPPI channel that task TRIGOVFLW will subscribe to																										
B	RW	EN	Disabled	0	Disable subscription																										
			Enabled	1	Enable subscription																										

6.11.9.9 EVENTS_TICK

Address offset: 0x100

Event on counter increment

Bit number	31 30 29 28 27 26 25 24 23 22 21 20 19 18 17 16 15 14 13 12 11 10 9 8 7 6 5 4 3 2 1 0																														
ID																															A
Reset 0x00000000	0 0																														
ID	R/W	Field	Value ID	Value	Description																										
A	RW	EVENTS_TICK			Event on counter increment																										
			NotGenerated	0	Event not generated																										
			Generated	1	Event generated																										

6.11.9.10 EVENTS_OVRFLW

Address offset: 0x104

Event on counter overflow

Bit number	31	30	29	28	27	26	25	24	23	22	21	20	19	18	17	16	15	14	13	12	11	10	9	8	7	6	5	4	3	2	1	0
ID	A																															
Reset 0x00000000	0 0																															
ID	R/W	Field	Value ID	Value	Description																											
A	RW	EVENTS_OVRFLW			Event on counter overflow																											
			NotGenerated	0	Event not generated																											
			Generated	1	Event generated																											

6.11.9.11 EVENTS_COMPARE[n] (n=0..3)

Address offset: 0x140 + (n × 0x4)

Compare event on CC[n] match

Bit number	31	30	29	28	27	26	25	24	23	22	21	20	19	18	17	16	15	14	13	12	11	10	9	8	7	6	5	4	3	2	1	0
ID	A																															
Reset 0x00000000	0 0																															
ID	R/W	Field	Value ID	Value	Description																											
A	RW	EVENTS_COMPARE			Compare event on CC[n] match																											
			NotGenerated	0	Event not generated																											
			Generated	1	Event generated																											

6.11.9.12 PUBLISH_TICK

Address offset: 0x180

Publish configuration for event TICK

Bit number	31	30	29	28	27	26	25	24	23	22	21	20	19	18	17	16	15	14	13	12	11	10	9	8	7	6	5	4	3	2	1	0
ID	B															A A A A A A A A A A A A A A A A																
Reset 0x00000000	0 0																															
ID	R/W	Field	Value ID	Value	Description																											
A	RW	CHIDX		[0..255]	DPPI channel that event TICK will publish to																											
B	RW	EN																														
			Disabled	0	Disable publishing																											
			Enabled	1	Enable publishing																											

6.11.9.13 PUBLISH_OVRFLW

Address offset: 0x184

Publish configuration for event OVRFLW

Bit number	31	30	29	28	27	26	25	24	23	22	21	20	19	18	17	16	15	14	13	12	11	10	9	8	7	6	5	4	3	2	1	0
ID	B															A A A A A A A A A A A A A A A A																
Reset 0x00000000	0 0																															
ID	R/W	Field	Value ID	Value	Description																											
A	RW	CHIDX		[0..255]	DPPI channel that event OVRFLW will publish to																											
B	RW	EN																														
			Disabled	0	Disable publishing																											
			Enabled	1	Enable publishing																											

6.11.9.14 PUBLISH_COMPARE[n] (n=0..3)

Address offset: 0x1C0 + (n × 0x4)

Publish configuration for event COMPARE[n]

Bit number	31	30	29	28	27	26	25	24	23	22	21	20	19	18	17	16	15	14	13	12	11	10	9	8	7	6	5	4	3	2	1	0
ID	B																A A A A A A A A															
Reset 0x00000000	0 0																															
ID	R/W	Field	Value ID	Value	Description																											
A	RW	CHIDX		[0..255]	DPPI channel that event COMPARE[n] will publish to																											
B	RW	EN	Disabled	0	Disable publishing																											
			Enabled	1	Enable publishing																											

6.11.9.15 INTENSET

Address offset: 0x304

Enable interrupt

Bit number	31	30	29	28	27	26	25	24	23	22	21	20	19	18	17	16	15	14	13	12	11	10	9	8	7	6	5	4	3	2	1	0
ID	F E D C																B A															
Reset 0x00000000	0 0																															
ID	R/W	Field	Value ID	Value	Description																											
A	RW	TICK			Write '1' to enable interrupt for event TICK																											
			Set	1	Enable																											
			Disabled	0	Read: Disabled																											
			Enabled	1	Read: Enabled																											
B	RW	OVRFLW			Write '1' to enable interrupt for event OVRFLW																											
			Set	1	Enable																											
			Disabled	0	Read: Disabled																											
			Enabled	1	Read: Enabled																											
C-F	RW	COMPARE[i] (i=0..3)			Write '1' to enable interrupt for event COMPARE[i]																											
			Set	1	Enable																											
			Disabled	0	Read: Disabled																											
			Enabled	1	Read: Enabled																											

6.11.9.16 INTENCLR

Address offset: 0x308

Disable interrupt

Bit number	31	30	29	28	27	26	25	24	23	22	21	20	19	18	17	16	15	14	13	12	11	10	9	8	7	6	5	4	3	2	1	0
ID	F E D C																B A															
Reset 0x00000000	0 0																															
ID	R/W	Field	Value ID	Value	Description																											
A	RW	TICK			Write '1' to disable interrupt for event TICK																											
			Clear	1	Disable																											
			Disabled	0	Read: Disabled																											
			Enabled	1	Read: Enabled																											
B	RW	OVRFLW			Write '1' to disable interrupt for event OVRFLW																											
			Clear	1	Disable																											
			Disabled	0	Read: Disabled																											
			Enabled	1	Read: Enabled																											
C-F	RW	COMPARE[i] (i=0..3)			Write '1' to disable interrupt for event COMPARE[i]																											
			Clear	1	Disable																											

Bit number	31	30	29	28	27	26	25	24	23	22	21	20	19	18	17	16	15	14	13	12	11	10	9	8	7	6	5	4	3	2	1	0
ID														F	E	D	C														B	A
Reset 0x00000000	0 0																															
ID	R/W	Field	Value ID	Value	Description																											
			Disabled	0	Read: Disabled																											
			Enabled	1	Read: Enabled																											

6.11.9.17 EVTEN

Address offset: 0x340

Enable or disable event routing

Bit number	31	30	29	28	27	26	25	24	23	22	21	20	19	18	17	16	15	14	13	12	11	10	9	8	7	6	5	4	3	2	1	0
ID														F	E	D	C														B	A
Reset 0x00000000	0 0																															
ID	R/W	Field	Value ID	Value	Description																											
A	RW	TICK			Enable or disable event routing for event TICK																											
			Disabled	0	Disable																											
			Enabled	1	Enable																											
B	RW	OVRFLW			Enable or disable event routing for event OVRFLW																											
			Disabled	0	Disable																											
			Enabled	1	Enable																											
C-F	RW	COMPARE[i] (i=0..3)			Enable or disable event routing for event COMPARE[i]																											
			Disabled	0	Disable																											
			Enabled	1	Enable																											

6.11.9.18 EVTENSET

Address offset: 0x344

Enable event routing

Bit number	31	30	29	28	27	26	25	24	23	22	21	20	19	18	17	16	15	14	13	12	11	10	9	8	7	6	5	4	3	2	1	0
ID														F	E	D	C														B	A
Reset 0x00000000	0 0																															
ID	R/W	Field	Value ID	Value	Description																											
A	RW	TICK			Write '1' to enable event routing for event TICK																											
			Disabled	0	Read: Disabled																											
			Enabled	1	Read: Enabled																											
			Set	1	Enable																											
B	RW	OVRFLW			Write '1' to enable event routing for event OVRFLW																											
			Disabled	0	Read: Disabled																											
			Enabled	1	Read: Enabled																											
			Set	1	Enable																											
C-F	RW	COMPARE[i] (i=0..3)			Write '1' to enable event routing for event COMPARE[i]																											
			Disabled	0	Read: Disabled																											
			Enabled	1	Read: Enabled																											
			Set	1	Enable																											

6.11.9.19 EVTENCLR

Address offset: 0x348

Disable event routing

Bit number	31 30 29 28 27 26 25 24 23 22 21 20 19 18 17 16 15 14 13 12 11 10 9 8 7 6 5 4 3 2 1 0																																						
ID																								F	E	D	C											B	A
Reset 0x00000000	0 0																																						
ID	R/W	Field	Value ID	Value	Description																																		
A	RW	TICK			Write '1' to disable event routing for event TICK																																		
			Disabled	0	Read: Disabled																																		
			Enabled	1	Read: Enabled																																		
B	RW	OVRFLW	Clear	1	Disable																																		
			Disabled	0	Read: Disabled																																		
			Enabled	1	Read: Enabled																																		
C-F	RW	COMPARE[i] (i=0..3)	Clear	1	Disable																																		
			Disabled	0	Read: Disabled																																		
			Enabled	1	Read: Enabled																																		

6.11.9.20 COUNTER

Address offset: 0x504

Current counter value

Bit number	31 30 29 28 27 26 25 24 23 22 21 20 19 18 17 16 15 14 13 12 11 10 9 8 7 6 5 4 3 2 1 0																																																			
ID																								A	A	A	A	A	A	A	A	A	A	A	A	A	A	A	A	A	A	A	A	A	A	A	A	A	A	A	A	A
Reset 0x00000000	0 0																																																			
ID	R/W	Field	Value ID	Value	Description																																															
A	R	COUNTER			Counter value																																															

6.11.9.21 PRESCALER

Address offset: 0x508

12-bit prescaler for counter frequency ($32768 / (\text{PRESCALER} + 1)$). Must be written when RTC is stopped.

Bit number	31 30 29 28 27 26 25 24 23 22 21 20 19 18 17 16 15 14 13 12 11 10 9 8 7 6 5 4 3 2 1 0																																																			
ID																								A	A	A	A	A	A	A	A	A	A	A	A	A	A	A	A	A	A	A	A	A	A	A	A	A	A	A	A	A
Reset 0x00000000	0 0																																																			
ID	R/W	Field	Value ID	Value	Description																																															
A	RW	PRESCALER			Prescaler value																																															

6.11.9.22 CC[n] (n=0..3)

Address offset: $0x540 + (n \times 0x4)$

Compare register n

Bit number	31 30 29 28 27 26 25 24 23 22 21 20 19 18 17 16 15 14 13 12 11 10 9 8 7 6 5 4 3 2 1 0																																																			
ID																								A	A	A	A	A	A	A	A	A	A	A	A	A	A	A	A	A	A	A	A	A	A	A	A	A	A	A	A	A
Reset 0x00000000	0 0																																																			
ID	R/W	Field	Value ID	Value	Description																																															
A	RW	COMPARE			Compare value																																															

6.12 SAADC — Successive approximation analog-to-digital converter

The SAADC is a differential successive approximation register (SAR) analog-to-digital converter.

Listed here are the main features of SAADC:

- 8/10/12-bit resolution, 14-bit resolution with oversampling
- Multiple analog inputs:
 - AIN0 to AIN7 pins
 - VDD_GPIO pin
- Up to eight input channels:
 - One channel per single-ended input and two channels per differential input
 - Scan mode can be configured with both single-ended channels and differential channels
 - Each channel can be configured to select any of the above analog inputs
- Full scale input range (0 to VDD_GPIO)
- Sampling triggered via a task from software or a PPI channel for full flexibility on sample frequency source from low-power 32.768 kHz RTC or more accurate 1/16 MHz timers
- One-shot conversion mode to sample a single channel
- Scan mode to sample a series of channels in sequence with configurable sample delay
- Support for direct sample transfer to RAM using EasyDMA
- Interrupts on single sample and full buffer events
- Samples stored as 16-bit two's complement values for differential and single-ended sampling
- Continuous sampling without the need of an external timer
- Internal resistor string
- On-the-fly limit checking

6.12.1 Overview

The ADC supports up to eight external analog input channels. It can be operated in One-shot mode with sampling under software control, or Continuous mode with a programmable sampling rate.

The analog inputs can be configured as eight single-ended inputs, four differential inputs or a combination of these. Each channel can be configured to select:

- AIN0 to AIN7 pins
- VDD_GPIO pin

Channels can be sampled individually in one-shot or continuous sampling modes, or, using scan mode, multiple channels can be sampled in sequence. Channels can also be oversampled to improve noise performance.

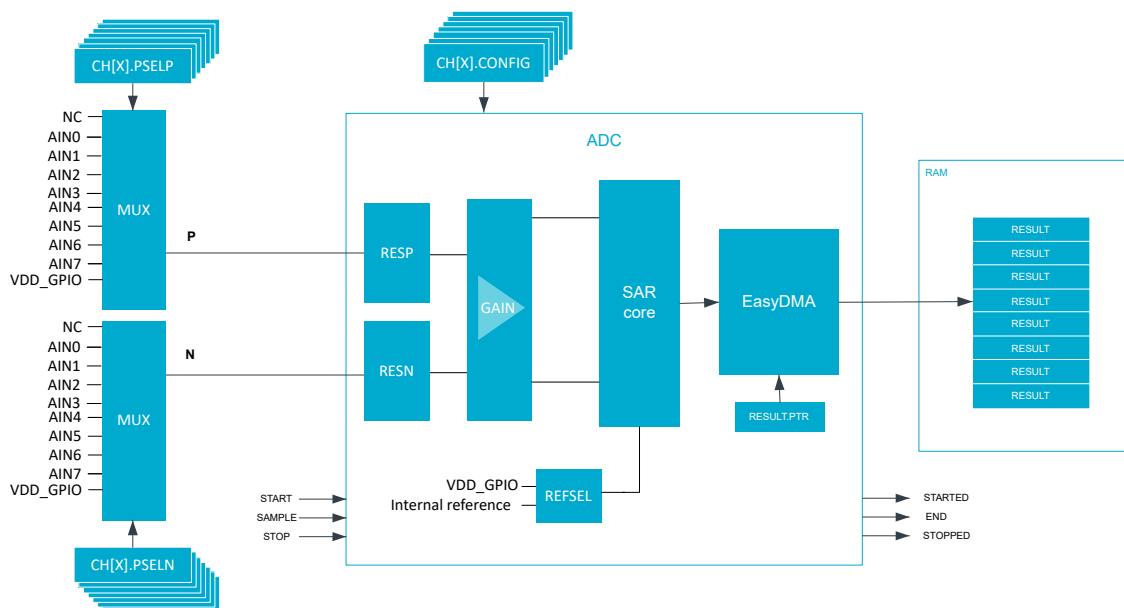

Figure 70: Simplified ADC block diagram

Internally, the ADC is always a differential analog-to-digital converter, but by default it is configured with single-ended input in the MODE field of the CH[n].CONFIG register. In single-ended mode, the negative input will be shorted to ground internally.

The assumption in single-ended mode is that the internal ground of the ADC is the same as the external ground that the measured voltage is referred to. The ADC is thus sensitive to ground bounce on the PCB in single-ended mode. If this is a concern, we recommend using differential measurement.

6.12.2 Digital output

The output result of the ADC depends on the settings in the CH[n].CONFIG and RESOLUTION registers as follows:

$$\text{RESULT} = [V(P) - V(N)] * \text{GAIN}/\text{REFERENCE} * 2^{(\text{RESOLUTION} - m)}$$

where

V(P)

is the voltage at input P

V(N)

is the voltage at input N

GAIN

is the selected gain setting

m

is the mode setting. Use m=0 if CONFIG.MODE=SE, or m=1 if CONFIG.MODE=Diff

REFERENCE

is the selected reference voltage

The result generated by the ADC will deviate from the expected due DC errors like offset, gain, differential non-linearity (DNL), and integral non-linearity (INL). See [Electrical specification](#) for details on these parameters. The result can also vary due to AC errors like non-linearities in the GAIN block, settling errors

due to high source impedance and sampling jitter. For battery measurement, the DC errors are most noticeable.

The ADC has a wide selection of gains controlled in the GAIN field of the CH[n].CONFIG register. If CH[n].CONFIG.REFSEL=0, the input range of the ADC core is nominally ± 0.6 V differential and the input must be scaled accordingly.

Calibration

The ADC has a temperature dependent offset. If the ADC is to operate over a large temperature range, we recommend running TASKS_CALIBRATEOFFSET at regular intervals.

The DONE, RESULTDONE, and CALIBRATEDONE events are fired when the calibration has been completed.

The offset calibration must be run when the SAADC is stopped. If the TASKS_CALIBRATEOFFSET is run when the SAADC is started, then RAM may contain values not related to the ADC input.

6.12.3 Analog inputs and channels

Up to eight analog input channels, CH[n](n=0..7), can be configured.

Any one of the available channels can be enabled for the ADC to operate in one-shot mode. If more than one CH[n] is configured, the ADC enters scan mode.

An analog input is selected as a positive converter input if CH[n].PSELP is set, setting CH[n].PSELP also enables the particular channel.

An analog input is selected as a negative converter input if CH[n].PSELN is set. The CH[n].PSELN register will have no effect unless differential mode is enabled, see MODE field in CH[n].CONFIG register.

If more than one of the CH[n].PSELP registers is set, the device enters scan mode. Input selections in scan mode are controlled by the CH[n].PSELP and CH[n].PSELN registers, where CH[n].PSELN is only used if the particular scan channel is specified as differential, see MODE field in CH[n].CONFIG register.

6.12.4 Operation modes

The ADC input configuration supports one-shot mode, continuous mode, and scan mode.

Note: Scan mode and oversampling cannot be combined.

The ADC indicates a single ongoing conversion via the register STATUS on page 287. During scan mode, oversampling, or continuous modes, more than a single conversion take place in the ADC. As consequence, the value reflected in STATUS register will toggle at the end of each single conversion.

6.12.4.1 One-shot mode

One-shot operation is configured by enabling only one of the available channels defined by CH[n].PSELP, CH[n].PSELN, and CH[n].CONFIG registers.

Upon a SAMPLE task, the ADC starts to sample the input voltage. The CH[n].CONFIG.TACQ controls the acquisition time.

A DONE event signals that one sample has been taken.

In this mode, the RESULTDONE event has the same meaning as DONE when no oversampling takes place. Note that both events may occur before the actual value has been transferred into RAM by EasyDMA. For more information, see EasyDMA on page 270.

6.12.4.2 Continuous mode

Continuous sampling can be achieved by using the internal timer in the ADC, or triggering the SAMPLE task from one of the general purpose timers through the PPI system.

Care shall be taken to ensure that the sample rate fulfils the following criteria, depending on how many channels are active:

$$f_{\text{SAMPLE}} < 1 / (t_{\text{ACQ}} + t_{\text{CONV}})$$

The SAMPLERATE register can be used as a local timer instead of triggering individual SAMPLE tasks. When SAMPLERATE.MODE is set to Timers, it is sufficient to trigger SAMPLE task only once in order to start the SAADC and triggering the STOP task will stop sampling. The SAMPLERATE.CC field controls the sample rate.

The SAMPLERATE timer mode cannot be combined with SCAN mode, and only one channel can be enabled in this mode.

A DONE event signals that one sample has been taken.

In this mode, the RESULTDONE event has the same meaning as DONE when no oversampling takes place. Note that both events may occur before the actual value has been transferred into RAM by EasyDMA.

6.12.4.3 Oversampling

An accumulator in the ADC can be used to average noise on the analog input. In general, oversampling improves the signal-to-noise ratio (SNR). However, oversampling does not improve the integral non-linearity (INL) nor the differential non-linearity (DNL).

Oversampling and scan should not be combined, since oversampling and scan will average over input channels.

The accumulator is controlled in the OVERSAMPLE register. The SAMPLE task must be set $2^{\text{OVERSAMPLE}}$ number of times before the result is written to RAM. This can be achieved by:

- Configuring a fixed sampling rate using the local timer or a general purpose timer and the PPI system to trigger a SAMPLE task
- Triggering SAMPLE $2^{\text{OVERSAMPLE}}$ times from software
- Enabling BURST mode

CH[n].CONFIG.BURST can be enabled to avoid setting SAMPLE task $2^{\text{OVERSAMPLE}}$ times. With BURST = 1 the ADC will sample the input $2^{\text{OVERSAMPLE}}$ times as fast as it can (actual timing: $<(t_{\text{ACQ}}+t_{\text{CONV}}) \times 2^{\text{OVERSAMPLE}}>$). Thus, for the user it will just appear like the conversion took a bit longer time, but other than that, it is similar to one-shot mode.

A DONE event signals that one sample has been taken.

In this mode, the RESULTDONE event signals that enough conversions have taken place for an oversampled result to get transferred into RAM. Note that both events may occur before the actual value has been transferred into RAM by EasyDMA.

6.12.4.4 Scan mode

A channel is considered enabled if CH[n].PSEL is set. If more than one channel, CH[n], is enabled, the ADC enters scan mode.

In scan mode, one SAMPLE task will trigger one conversion per enabled channel. The time it takes to sample all channels is:

$$\text{Total time} < \text{Sum}(\text{CH}[x].t_{\text{ACQ}}+t_{\text{CONV}}), \quad x=0.. \text{enabled channels}$$

A DONE event signals that one sample has been taken.

In this mode, the RESULTDONE event signals has the same meaning as DONE when no oversampling takes place. Note that both events may occur before the actual values have been transferred into RAM by EasyDMA.

The following figure shows an example of results placement in Data RAM, with an even RESULT.MAXCNT. In this example, channels 1, 2, and 5 are enabled, all others are disabled.

	31	16	15	0
RESULT.PTR	CH[2] 1 st result		CH[1] 1 st result	
RESULT.PTR + 4	CH[1] 2 nd result		CH[5] 1 st result	
RESULT.PTR + 8	CH[5] 2 nd result		CH[2] 2 nd result	
	(...)			
RESULT.PTR + 2*(RESULT.MAXCNT - 2)	CH[5] last result		CH[2] last result	

Figure 71: Example of RAM placement (even RESULT.MAXCNT), channels 1, 2 and 5 enabled

The following figure shows an example of results placement in Data RAM, with an odd RESULT.MAXCNT. In this example, channels 1, 2, and 5 are enabled, all others are disabled. The last 32-bit word is populated only with one 16-bit result.

	31	16	15	0
RESULT.PTR	CH[2] 1 st result		CH[1] 1 st result	
RESULT.PTR + 4	CH[1] 2 nd result		CH[5] 1 st result	
RESULT.PTR + 8	CH[5] 2 nd result		CH[2] 2 nd result	
	(...)			
RESULT.PTR + 2*(RESULT.MAXCNT - 1)			CH[5] last result	

Figure 72: Example of RAM placement (odd RESULT.MAXCNT), channels 1, 2 and 5 enabled

6.12.5 EasyDMA

After configuring RESULT.PTR and RESULT.MAXCNT, the ADC resources are started by triggering the START task. The ADC is using EasyDMA to store results in a Result buffer in RAM.

The Result buffer is located at the address specified in the RESULT.PTR register. The RESULT.PTR register is double-buffered and it can be updated and prepared for the next START task immediately after the STARTED event is generated. The size of the Result buffer is specified in the RESULT.MAXCNT register and the ADC will generate an END event when it has filled up the Result buffer, see [ADC](#) on page 271. Results are stored in little-endian byte order in Data RAM. Every sample will be sign extended to 16 bit before stored in the Result buffer.

The ADC is stopped by triggering the STOP task. The STOP task will terminate an ongoing sampling. The ADC will generate a STOPPED event when it has stopped. If the ADC is already stopped when the STOP task is triggered, the STOPPED event will still be generated.

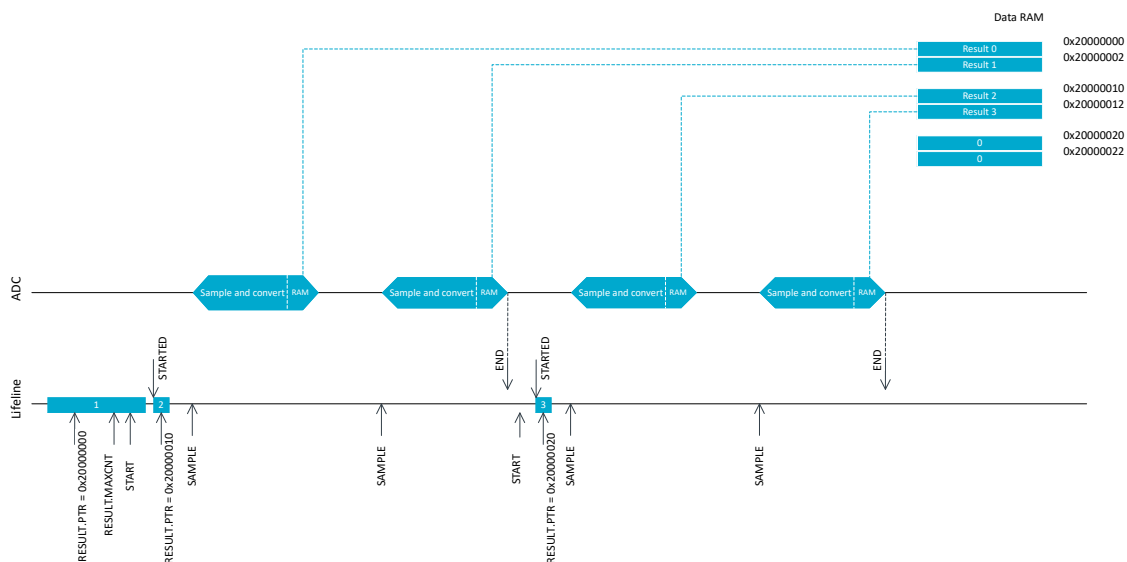

Figure 73: ADC

If the RESULT.PTR is not pointing to a RAM region accessible from the peripheral, an EasyDMA transfer may result in a HardFault and/or memory corruption. See [Memory](#) on page 23 for more information about the different memory regions.

The EasyDMA will have finished accessing the RAM when the END or STOPPED event has been generated.

The RESULT.AMOUNT register can be read following an END event or a STOPPED event to see how many results have been transferred to the Result buffer in RAM since the START task was triggered.

In scan mode, SAMPLE tasks can be triggered once the START task is triggered. The END event is generated when the number of samples transferred to memory reaches the value specified by RESULT.MAXCNT. After an END event, the START task needs to be triggered again before new samples can be taken. Also make sure that the size of the Result buffer is large enough to have space for minimum one result from each of the enabled channels, by specifying RESULT.MAXCNT \geq number of channels enabled. For more information about the scan mode, see [Scan mode](#) on page 269.

6.12.6 Resistor ladder

The ADC has an internal resistor string for positive and negative input.

See [Resistor ladder for positive input \(negative input is equivalent, using RESN instead of RESP\)](#) on page 272. The resistors are controlled in the CH[n].CONFIG.RESP and CH[n].CONFIG.RESN registers.

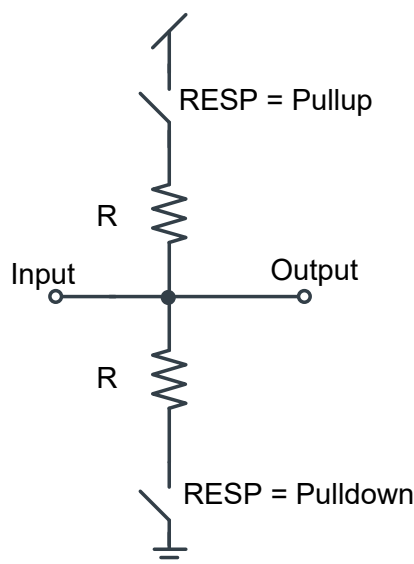

Figure 74: Resistor ladder for positive input (negative input is equivalent, using RESN instead of RESP)

6.12.7 Reference

The ADC can use two different references, controlled in the REFSEL field of the CH[n].CONFIG register.

These are:

- Internal reference
- VDD_GPIO as reference

The internal reference results in an input range of ± 0.6 V on the ADC core. VDD_GPIO as reference results in an input range of $\pm VDD_GPIO/4$ on the ADC core. The gain block can be used to change the effective input range of the ADC.

$$\text{Input range} = (\pm 0.6 \text{ V or } \pm VDD_GPIO/4) / \text{Gain}$$

For example, choosing VDD_GPIO as reference, single ended input (grounded negative input), and a gain of 1/4 the input range will be:

$$\text{Input range} = (VDD_GPIO/4) / (1/4) = VDD_GPIO$$

With internal reference, single ended input (grounded negative input), and a gain of 1/6 the input range will be:

$$\text{Input range} = (0.6 \text{ V}) / (1/6) = 3.6 \text{ V}$$

The AIN0-AIN7 inputs cannot exceed VDD_GPIO, or be lower than VSS.

6.12.8 Acquisition time

To sample the input voltage, the ADC connects a capacitor to the input.

For illustration, see [Simplified ADC sample network](#) on page 273. The acquisition time indicates how long the capacitor is connected, see TACQ field in CH[n].CONFIG register. The required acquisition time depends on the source (R_{source}) resistance. For high source resistance the acquisition time should be increased, see [Acquisition time](#) on page 273.

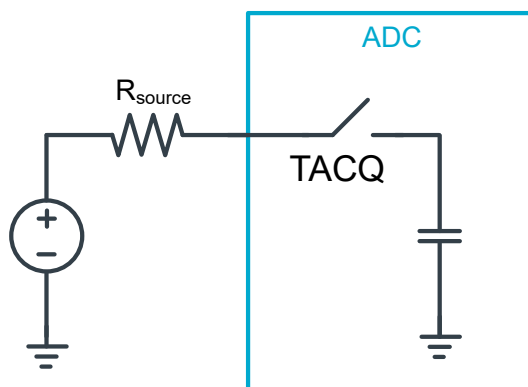

Figure 75: Simplified ADC sample network

TACQ [μ s]	Maximum source resistance [kOhm]
3	10
5	40
10	100
15	200
20	400
40	800

Table 32: Acquisition time

6.12.9 Limits event monitoring

A channel can be event monitored by configuring limit register CH[n].LIMIT.

If the conversion result is higher than the defined high limit, or lower than the defined low limit, the appropriate event will get fired.

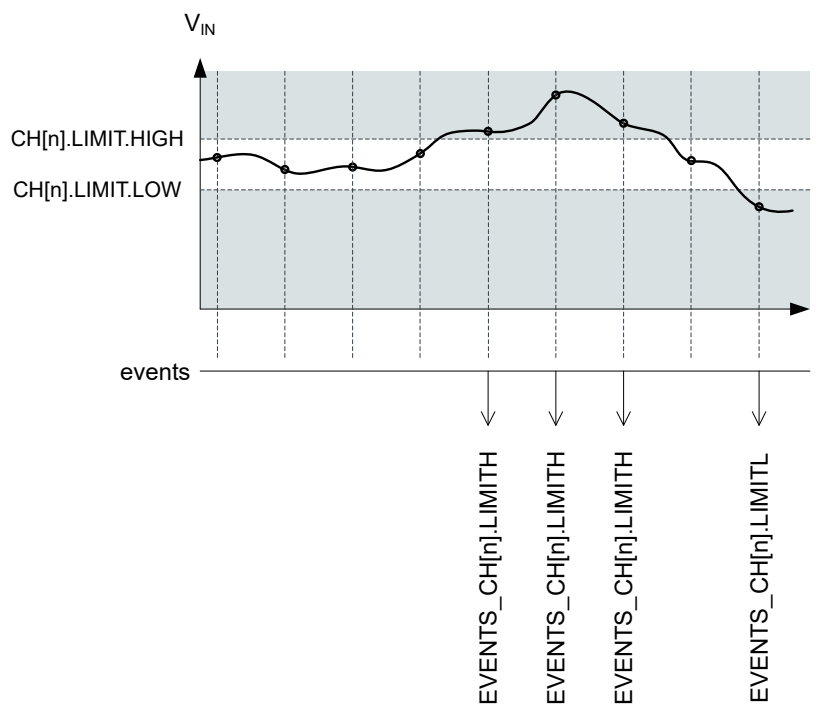

Figure 76: Example of limits monitoring on channel 'n'

Note that when setting the limits, CH[n].LIMIT.HIGH shall always be higher than or equal to CH[n].LIMIT.LOW . In other words, an event can be fired only when the input signal has been sampled outside of the defined limits. It is not possible to fire an event when the input signal is inside a defined range by swapping high and low limits.

The comparison to limits always takes place, there is no need to enable it. If comparison is not required on a channel, the software shall simply ignore the related events. In that situation, the value of the limits registers is irrelevant, so it does not matter if CH[n].LIMIT.LOW is lower than CH[n].LIMIT.HIGH or not.

6.12.10 Registers

Instances

Instance	Base address	TrustZone			Split access	Description
		Map	Att	DMA		
SAADC : S	0x5000E000	US	NS	SA	No	Analog to digital converter
SAADC : NS	0x4000E000					

Register overview

Register	Offset	TZ	Description
TASKS_START	0x000		Start the ADC and prepare the result buffer in RAM
TASKS_SAMPLE	0x004		Take one ADC sample, if scan is enabled all channels are sampled
TASKS_STOP	0x008		Stop the ADC and terminate any on-going conversion
TASKS_CALIBRATEOFFSET	0x00C		Starts offset auto-calibration
SUBSCRIBE_START	0x080		Subscribe configuration for task START
SUBSCRIBE_SAMPLE	0x084		Subscribe configuration for task SAMPLE
SUBSCRIBE_STOP	0x088		Subscribe configuration for task STOP
SUBSCRIBE_CALIBRATEOFFSET	0x08C		Subscribe configuration for task CALIBRATEOFFSET
EVENTS_STARTED	0x100		The ADC has started
EVENTS_END	0x104		The ADC has filled up the Result buffer
EVENTS_DONE	0x108		A conversion task has been completed. Depending on the mode, multiple conversions might be needed for a result to be transferred to RAM.
EVENTS_RESULTDONE	0x10C		A result is ready to get transferred to RAM.
EVENTS_CALIBRATEDONE	0x110		Calibration is complete
EVENTS_STOPPED	0x114		The ADC has stopped
EVENTS_CH[n].LIMITH	0x118		Last results is equal or above CH[n].LIMIT.HIGH
EVENTS_CH[n].LIMITL	0x11C		Last results is equal or below CH[n].LIMIT.LOW
PUBLISH_STARTED	0x180		Publish configuration for event STARTED
PUBLISH_END	0x184		Publish configuration for event END
PUBLISH_DONE	0x188		Publish configuration for event DONE
PUBLISH_RESULTDONE	0x18C		Publish configuration for event RESULTDONE
PUBLISH_CALIBRATEDONE	0x190		Publish configuration for event CALIBRATEDONE
PUBLISH_STOPPED	0x194		Publish configuration for event STOPPED
PUBLISH_CH[n].LIMITH	0x198		Publish configuration for event CH[n].LIMITH
PUBLISH_CH[n].LIMITL	0x19C		Publish configuration for event CH[n].LIMITL
INTEN	0x300		Enable or disable interrupt
INTENSET	0x304		Enable interrupt
INTENCLR	0x308		Disable interrupt
STATUS	0x400		Status
ENABLE	0x500		Enable or disable ADC
CH[n].PSEL	0x510		Input positive pin selection for CH[n]
CH[n].PSELN	0x514		Input negative pin selection for CH[n]

Register	Offset	TZ	Description
CH[n].CONFIG	0x518		Input configuration for CH[n]
CH[n].LIMIT	0x51C		High/low limits for event monitoring a channel
RESOLUTION	0x5F0		Resolution configuration
OVERSAMPLE	0x5F4		Oversampling configuration. OVERSAMPLE should not be combined with SCAN. The RESOLUTION is applied before averaging, thus for high OVERSAMPLE a higher RESOLUTION should be used.
SAMPLERATE	0x5F8		Controls normal or continuous sample rate
RESULT.PTR	0x62C		Data pointer
RESULT.MAXCNT	0x630		Maximum number of buffer words to transfer
RESULT.AMOUNT	0x634		Number of buffer words transferred since last START

6.12.10.1 TASKS_START

Address offset: 0x000

Start the ADC and prepare the result buffer in RAM

Bit number	31	30	29	28	27	26	25	24	23	22	21	20	19	18	17	16	15	14	13	12	11	10	9	8	7	6	5	4	3	2	1	0
ID																																A
Reset 0x00000000	0 0																															
ID	R/W	Field	Value ID	Value	Description																											
A	W	TASKS_START			Start the ADC and prepare the result buffer in RAM																											
			Trigger	1	Trigger task																											

6.12.10.2 TASKS_SAMPLE

Address offset: 0x004

Take one ADC sample, if scan is enabled all channels are sampled

Bit number	31	30	29	28	27	26	25	24	23	22	21	20	19	18	17	16	15	14	13	12	11	10	9	8	7	6	5	4	3	2	1	0
ID																																A
Reset 0x00000000	0 0																															
ID	R/W	Field	Value ID	Value	Description																											
A	W	TASKS_SAMPLE			Take one ADC sample, if scan is enabled all channels are sampled																											
			Trigger	1	Trigger task																											

6.12.10.3 TASKS_STOP

Address offset: 0x008

Stop the ADC and terminate any on-going conversion

Bit number	31	30	29	28	27	26	25	24	23	22	21	20	19	18	17	16	15	14	13	12	11	10	9	8	7	6	5	4	3	2	1	0
ID																																A
Reset 0x00000000	0 0																															
ID	R/W	Field	Value ID	Value	Description																											
A	W	TASKS_STOP			Stop the ADC and terminate any on-going conversion																											
			Trigger	1	Trigger task																											

6.12.10.4 TASKS_CALIBRATEOFFSET

Address offset: 0x00C

Starts offset auto-calibration

Do not trigger when the ADC has been started

Bit number	31 30 29 28 27 26 25 24 23 22 21 20 19 18 17 16 15 14 13 12 11 10 9 8 7 6 5 4 3 2 1 0																														
ID	A																														
Reset	0x00000000																														
	0 0																														
ID	R/W	Field	Value ID	Value	Description																										
A	W	TASKS_CALIBRATEOFFSET			Starts offset auto-calibration																										
			Trigger	1	Do not trigger when the ADC has been started Trigger task																										

6.12.10.5 SUBSCRIBE_START

Address offset: 0x080

Subscribe configuration for task **START**

Bit number	31 30 29 28 27 26 25 24 23 22 21 20 19 18 17 16 15 14 13 12 11 10 9 8 7 6 5 4 3 2 1 0																														
ID	B																														
Reset	0x00000000																														
	0 0																														
ID	R/W	Field	Value ID	Value	Description																										
A	RW	CHIDX		[0..255]	DPPI channel that task START will subscribe to																										
B	RW	EN	Disabled	0	Disable subscription																										
			Enabled	1	Enable subscription																										

6.12.10.6 SUBSCRIBE_SAMPLE

Address offset: 0x084

Subscribe configuration for task **SAMPLE**

Bit number	31 30 29 28 27 26 25 24 23 22 21 20 19 18 17 16 15 14 13 12 11 10 9 8 7 6 5 4 3 2 1 0																														
ID	B																														
Reset	0x00000000																														
	0 0																														
ID	R/W	Field	Value ID	Value	Description																										
A	RW	CHIDX		[0..255]	DPPI channel that task SAMPLE will subscribe to																										
B	RW	EN	Disabled	0	Disable subscription																										
			Enabled	1	Enable subscription																										

6.12.10.7 SUBSCRIBE_STOP

Address offset: 0x088

Subscribe configuration for task **STOP**

Bit number	31 30 29 28 27 26 25 24 23 22 21 20 19 18 17 16 15 14 13 12 11 10 9 8 7 6 5 4 3 2 1 0																														
ID	B																														
Reset	0x00000000																														
	0 0																														
ID	R/W	Field	Value ID	Value	Description																										
A	RW	CHIDX		[0..255]	DPPI channel that task STOP will subscribe to																										
B	RW	EN	Disabled	0	Disable subscription																										
			Enabled	1	Enable subscription																										

6.12.10.8 SUBSCRIBE_CALIBRATEOFFSET

Address offset: 0x08C

Subscribe configuration for task CALIBRATEOFFSET

Do not trigger when the ADC has been started

Bit number	31	30	29	28	27	26	25	24	23	22	21	20	19	18	17	16	15	14	13	12	11	10	9	8	7	6	5	4	3	2	1	0							
ID	B																							A				A				A				A			
Reset 0x00000000	0 0																																						
ID	R/W	Field	Value ID	Value	Description																																		
A	RW	CHIDX		[0..255]	DPPI channel that task CALIBRATEOFFSET will subscribe to																																		
B	RW	EN	Disabled	0	Disable subscription																																		
			Enabled	1	Enable subscription																																		

6.12.10.9 EVENTS_STARTED

Address offset: 0x100

The ADC has started

Bit number	31	30	29	28	27	26	25	24	23	22	21	20	19	18	17	16	15	14	13	12	11	10	9	8	7	6	5	4	3	2	1	0	
ID																																	A
Reset 0x00000000	0 0																																
ID	R/W	Field	Value ID	Value	Description																												
A	RW	EVENTS_STARTED			The ADC has started																												
			NotGenerated	0	Event not generated																												
			Generated	1	Event generated																												

6.12.10.10 EVENTS_END

Address offset: 0x104

The ADC has filled up the Result buffer

Bit number	31	30	29	28	27	26	25	24	23	22	21	20	19	18	17	16	15	14	13	12	11	10	9	8	7	6	5	4	3	2	1	0	
ID																																	A
Reset 0x00000000	0 0																																
ID	R/W	Field	Value ID	Value	Description																												
A	RW	EVENTS_END			The ADC has filled up the Result buffer																												
			NotGenerated	0	Event not generated																												
			Generated	1	Event generated																												

6.12.10.11 EVENTS_DONE

Address offset: 0x108

A conversion task has been completed. Depending on the mode, multiple conversions might be needed for a result to be transferred to RAM.

Bit number	31	30	29	28	27	26	25	24	23	22	21	20	19	18	17	16	15	14	13	12	11	10	9	8	7	6	5	4	3	2	1	0
ID																																A
Reset	0x00000000																															
	0 0																															
ID	R/W	Field	Value ID	Value	Description																											
A	RW	EVENTS_DONE			A conversion task has been completed. Depending on the mode, multiple conversions might be needed for a result to be transferred to RAM.																											
			NotGenerated	0	Event not generated																											
			Generated	1	Event generated																											

6.12.10.12 EVENTS_RESULTDONE

Address offset: 0x10C

A result is ready to get transferred to RAM.

Bit number	31	30	29	28	27	26	25	24	23	22	21	20	19	18	17	16	15	14	13	12	11	10	9	8	7	6	5	4	3	2	1	0
ID																																A
Reset	0x00000000																															
	0 0																															
ID	R/W	Field	Value ID	Value	Description																											
A	RW	EVENTS_RESULTDONE			A result is ready to get transferred to RAM.																											
			NotGenerated	0	Event not generated																											
			Generated	1	Event generated																											

6.12.10.13 EVENTS_CALIBRATEDONE

Address offset: 0x110

Calibration is complete

Bit number	31	30	29	28	27	26	25	24	23	22	21	20	19	18	17	16	15	14	13	12	11	10	9	8	7	6	5	4	3	2	1	0
ID																																A
Reset	0x00000000																															
	0 0																															
ID	R/W	Field	Value ID	Value	Description																											
A	RW	EVENTS_CALIBRATEDONE			Calibration is complete																											
			NotGenerated	0	Event not generated																											
			Generated	1	Event generated																											

6.12.10.14 EVENTS_STOPPED

Address offset: 0x114

The ADC has stopped

Bit number	31	30	29	28	27	26	25	24	23	22	21	20	19	18	17	16	15	14	13	12	11	10	9	8	7	6	5	4	3	2	1	0
ID																																A
Reset	0x00000000																															
	0 0																															
ID	R/W	Field	Value ID	Value	Description																											
A	RW	EVENTS_STOPPED			The ADC has stopped																											
			NotGenerated	0	Event not generated																											
			Generated	1	Event generated																											

6.12.10.15 EVENTS_CH[n] (n=0..7)

Peripheral events.

6.12.10.15.1 EVENTS_CH[n].LIMITH (n=0..7)

Address offset: 0x118 + (n × 0x8)

Last results is equal or above CH[n].LIMIT.HIGH

Bit number	31	30	29	28	27	26	25	24	23	22	21	20	19	18	17	16	15	14	13	12	11	10	9	8	7	6	5	4	3	2	1	0
ID																																A
Reset 0x00000000	0 0																															
ID	R/W	Field	Value ID	Value	Description																											
A	RW	LIMITH			Last results is equal or above CH[n].LIMIT.HIGH																											
			NotGenerated	0	Event not generated																											
			Generated	1	Event generated																											

6.12.10.15.2 EVENTS_CH[n].LIMITL (n=0..7)

Address offset: 0x11C + (n × 0x8)

Last results is equal or below CH[n].LIMIT.LOW

Bit number	31	30	29	28	27	26	25	24	23	22	21	20	19	18	17	16	15	14	13	12	11	10	9	8	7	6	5	4	3	2	1	0
ID																																A
Reset 0x00000000	0 0																															
ID	R/W	Field	Value ID	Value	Description																											
A	RW	LIMITL			Last results is equal or below CH[n].LIMIT.LOW																											
			NotGenerated	0	Event not generated																											
			Generated	1	Event generated																											

6.12.10.16 PUBLISH_STARTED

Address offset: 0x180

Publish configuration for event **STARTED**

Bit number	31	30	29	28	27	26	25	24	23	22	21	20	19	18	17	16	15	14	13	12	11	10	9	8	7	6	5	4	3	2	1	0		
ID																B											A	A	A	A	A	A	A	A
Reset 0x00000000	0 0																																	
ID	R/W	Field	Value ID	Value	Description																													
A	RW	CHIDX		[0..255]	DPPI channel that event STARTED will publish to																													
B	RW	EN																																
			Disabled	0	Disable publishing																													
			Enabled	1	Enable publishing																													

6.12.10.17 PUBLISH_END

Address offset: 0x184

Publish configuration for event **END**

Bit number	31 30 29 28 27 26 25 24 23 22 21 20 19 18 17 16 15 14 13 12 11 10 9 8 7 6 5 4 3 2 1 0																														
ID	B																								A A A A A A A						
Reset 0x00000000	0 0																														
ID	R/W	Field	Value ID	Value	Description																										
A	RW	CHIDX		[0..255]	DPPI channel that event END will publish to																										
B	RW	EN	Disabled	0	Disable publishing																										
			Enabled	1	Enable publishing																										

6.12.10.18 PUBLISH_DONE

Address offset: 0x188

Publish configuration for event **DONE**

Bit number	31 30 29 28 27 26 25 24 23 22 21 20 19 18 17 16 15 14 13 12 11 10 9 8 7 6 5 4 3 2 1 0																														
ID	B																								A A A A A A A						
Reset 0x00000000	0 0																														
ID	R/W	Field	Value ID	Value	Description																										
A	RW	CHIDX		[0..255]	DPPI channel that event DONE will publish to																										
B	RW	EN	Disabled	0	Disable publishing																										
			Enabled	1	Enable publishing																										

6.12.10.19 PUBLISH_RESULTDONE

Address offset: 0x18C

Publish configuration for event **RESULTDONE**

Bit number	31 30 29 28 27 26 25 24 23 22 21 20 19 18 17 16 15 14 13 12 11 10 9 8 7 6 5 4 3 2 1 0																														
ID	B																								A A A A A A A						
Reset 0x00000000	0 0																														
ID	R/W	Field	Value ID	Value	Description																										
A	RW	CHIDX		[0..255]	DPPI channel that event RESULTDONE will publish to																										
B	RW	EN	Disabled	0	Disable publishing																										
			Enabled	1	Enable publishing																										

6.12.10.20 PUBLISH_CALIBRATEDONE

Address offset: 0x190

Publish configuration for event **CALIBRATEDONE**

Bit number	31 30 29 28 27 26 25 24 23 22 21 20 19 18 17 16 15 14 13 12 11 10 9 8 7 6 5 4 3 2 1 0																														
ID	B																								A A A A A A A						
Reset 0x00000000	0 0																														
ID	R/W	Field	Value ID	Value	Description																										
A	RW	CHIDX		[0..255]	DPPI channel that event CALIBRATEDONE will publish to																										
B	RW	EN	Disabled	0	Disable publishing																										
			Enabled	1	Enable publishing																										

6.12.10.21 PUBLISH_STOPPED

Address offset: 0x194

Publish configuration for event STOPPED

Bit number	31 30 29 28 27 26 25 24 23 22 21 20 19 18 17 16 15 14 13 12 11 10 9 8 7 6 5 4 3 2 1 0																														
ID	B																								A A A A A A A						
Reset 0x00000000	0 0																														
ID	R/W	Field	Value ID	Value	Description																										
A	RW	CHIDX		[0..255]	DPPI channel that event STOPPED will publish to																										
B	RW	EN	Disabled	0	Disable publishing																										
			Enabled	1	Enable publishing																										

6.12.10.22 PUBLISH_CH[n] (n=0..7)

Publish configuration for events

6.12.10.22.1 PUBLISH_CH[n].LIMITH (n=0..7)

Address offset: 0x198 + (n × 0x8)

Publish configuration for event CH[n].LIMITH

Bit number	31 30 29 28 27 26 25 24 23 22 21 20 19 18 17 16 15 14 13 12 11 10 9 8 7 6 5 4 3 2 1 0																														
ID	B																								A A A A A A A						
Reset 0x00000000	0 0																														
ID	R/W	Field	Value ID	Value	Description																										
A	RW	CHIDX		[0..255]	DPPI channel that event CH[n].LIMITH will publish to																										
B	RW	EN	Disabled	0	Disable publishing																										
			Enabled	1	Enable publishing																										

6.12.10.22.2 PUBLISH_CH[n].LIMITL (n=0..7)

Address offset: 0x19C + (n × 0x8)

Publish configuration for event CH[n].LIMITL

Bit number	31 30 29 28 27 26 25 24 23 22 21 20 19 18 17 16 15 14 13 12 11 10 9 8 7 6 5 4 3 2 1 0																														
ID	B																								A A A A A A A						
Reset 0x00000000	0 0																														
ID	R/W	Field	Value ID	Value	Description																										
A	RW	CHIDX		[0..255]	DPPI channel that event CH[n].LIMITL will publish to																										
B	RW	EN	Disabled	0	Disable publishing																										
			Enabled	1	Enable publishing																										

6.12.10.23 INTEN

Address offset: 0x300

Enable or disable interrupt

Bit number		31 30 29 28 27 26 25 24 23 22 21 20 19 18 17 16 15 14 13 12 11 10 9 8 7 6 5 4 3 2 1 0																											
ID		V U T S R Q P O N M L K J I H G F E D C B A																											
Reset 0x00000000		0 0																											
ID	R/W	Field	Value ID	Value	Description																								
A	RW	STARTED	Disabled	0	Disable																								
			Enabled	1	Enable																								
B	RW	END	Disabled	0	Disable																								
			Enabled	1	Enable																								
C	RW	DONE	Disabled	0	Disable																								
			Enabled	1	Enable																								
D	RW	RESULTDONE	Disabled	0	Disable																								
			Enabled	1	Enable																								
E	RW	CALIBRATEDONE	Disabled	0	Disable																								
			Enabled	1	Enable																								
F	RW	STOPPED	Disabled	0	Disable																								
			Enabled	1	Enable																								
G	RW	CH0LIMITH	Disabled	0	Disable																								
			Enabled	1	Enable																								
H	RW	CH0LIMITL	Disabled	0	Disable																								
			Enabled	1	Enable																								
I	RW	CH1LIMITH	Disabled	0	Disable																								
			Enabled	1	Enable																								
J	RW	CH1LIMITL	Disabled	0	Disable																								
			Enabled	1	Enable																								
K	RW	CH2LIMITH	Disabled	0	Disable																								
			Enabled	1	Enable																								
L	RW	CH2LIMITL	Disabled	0	Disable																								
			Enabled	1	Enable																								
M	RW	CH3LIMITH	Disabled	0	Disable																								
			Enabled	1	Enable																								
N	RW	CH3LIMITL	Disabled	0	Disable																								
			Enabled	1	Enable																								
O	RW	CH4LIMITH	Disabled	0	Disable																								
			Enabled	1	Enable																								
P	RW	CH4LIMITL	Disabled	0	Disable																								
			Enabled	1	Enable																								
Q	RW	CH5LIMITH	Disabled	0	Disable																								
			Enabled	1	Enable																								

Bit number	31 30 29 28 27 26 25 24 23 22 21 20 19 18 17 16 15 14 13 12 11 10 9 8 7 6 5 4 3 2 1 0																														
ID	V U T S R Q P O N M L K J I H G F E D C B A																														
Reset 0x00000000	0 0																														
ID	R/W	Field	Value ID	Value	Description																										
			Enabled	1	Enable																										
R	RW	CH5LIMITL			Enable or disable interrupt for event CH5LIMITL																										
			Disabled	0	Disable																										
			Enabled	1	Enable																										
S	RW	CH6LIMITH			Enable or disable interrupt for event CH6LIMITH																										
			Disabled	0	Disable																										
			Enabled	1	Enable																										
T	RW	CH6LIMITL			Enable or disable interrupt for event CH6LIMITL																										
			Disabled	0	Disable																										
			Enabled	1	Enable																										
U	RW	CH7LIMITH			Enable or disable interrupt for event CH7LIMITH																										
			Disabled	0	Disable																										
			Enabled	1	Enable																										
V	RW	CH7LIMITL			Enable or disable interrupt for event CH7LIMITL																										
			Disabled	0	Disable																										
			Enabled	1	Enable																										

6.12.10.24 INTENSET

Address offset: 0x304

Enable interrupt

Bit number	31 30 29 28 27 26 25 24 23 22 21 20 19 18 17 16 15 14 13 12 11 10 9 8 7 6 5 4 3 2 1 0																														
ID	V U T S R Q P O N M L K J I H G F E D C B A																														
Reset 0x00000000	0 0																														
ID	R/W	Field	Value ID	Value	Description																										
A	RW	STARTED			Write '1' to enable interrupt for event STARTED																										
			Set	1	Enable																										
			Disabled	0	Read: Disabled																										
			Enabled	1	Read: Enabled																										
B	RW	END			Write '1' to enable interrupt for event END																										
			Set	1	Enable																										
			Disabled	0	Read: Disabled																										
			Enabled	1	Read: Enabled																										
C	RW	DONE			Write '1' to enable interrupt for event DONE																										
			Set	1	Enable																										
			Disabled	0	Read: Disabled																										
			Enabled	1	Read: Enabled																										
D	RW	RESULTDONE			Write '1' to enable interrupt for event RESULTDONE																										
			Set	1	Enable																										
			Disabled	0	Read: Disabled																										
			Enabled	1	Read: Enabled																										
E	RW	CALIBRATEDONE			Write '1' to enable interrupt for event CALIBRATEDONE																										
			Set	1	Enable																										
			Disabled	0	Read: Disabled																										
			Enabled	1	Read: Enabled																										
F	RW	STOPPED			Write '1' to enable interrupt for event STOPPED																										
			Set	1	Enable																										
			Disabled	0	Read: Disabled																										

Bit number		31 30 29 28 27 26 25 24 23 22 21 20 19 18 17 16 15 14 13 12 11 10 9 8 7 6 5 4 3 2 1 0																											
ID		V U T S R Q P O N M L K J I H G F E D C B A																											
Reset 0x00000000		0 0																											
ID	R/W	Field	Value ID	Value	Description																								
			Enabled	1	Read: Enabled																								
G	RW	CH0LIMITH			Write '1' to enable interrupt for event CH0LIMITH																								
			Set	1	Enable																								
			Disabled	0	Read: Disabled																								
			Enabled	1	Read: Enabled																								
H	RW	CH0LIMITL			Write '1' to enable interrupt for event CH0LIMITL																								
			Set	1	Enable																								
			Disabled	0	Read: Disabled																								
			Enabled	1	Read: Enabled																								
I	RW	CH1LIMITH			Write '1' to enable interrupt for event CH1LIMITH																								
			Set	1	Enable																								
			Disabled	0	Read: Disabled																								
			Enabled	1	Read: Enabled																								
J	RW	CH1LIMITL			Write '1' to enable interrupt for event CH1LIMITL																								
			Set	1	Enable																								
			Disabled	0	Read: Disabled																								
			Enabled	1	Read: Enabled																								
K	RW	CH2LIMITH			Write '1' to enable interrupt for event CH2LIMITH																								
			Set	1	Enable																								
			Disabled	0	Read: Disabled																								
			Enabled	1	Read: Enabled																								
L	RW	CH2LIMITL			Write '1' to enable interrupt for event CH2LIMITL																								
			Set	1	Enable																								
			Disabled	0	Read: Disabled																								
			Enabled	1	Read: Enabled																								
M	RW	CH3LIMITH			Write '1' to enable interrupt for event CH3LIMITH																								
			Set	1	Enable																								
			Disabled	0	Read: Disabled																								
			Enabled	1	Read: Enabled																								
N	RW	CH3LIMITL			Write '1' to enable interrupt for event CH3LIMITL																								
			Set	1	Enable																								
			Disabled	0	Read: Disabled																								
			Enabled	1	Read: Enabled																								
O	RW	CH4LIMITH			Write '1' to enable interrupt for event CH4LIMITH																								
			Set	1	Enable																								
			Disabled	0	Read: Disabled																								
			Enabled	1	Read: Enabled																								
P	RW	CH4LIMITL			Write '1' to enable interrupt for event CH4LIMITL																								
			Set	1	Enable																								
			Disabled	0	Read: Disabled																								
			Enabled	1	Read: Enabled																								
Q	RW	CH5LIMITH			Write '1' to enable interrupt for event CH5LIMITH																								
			Set	1	Enable																								
			Disabled	0	Read: Disabled																								
			Enabled	1	Read: Enabled																								
R	RW	CH5LIMITL			Write '1' to enable interrupt for event CH5LIMITL																								
			Set	1	Enable																								
			Disabled	0	Read: Disabled																								
			Enabled	1	Read: Enabled																								
S	RW	CH6LIMITH			Write '1' to enable interrupt for event CH6LIMITH																								

Bit number	31 30 29 28 27 26 25 24 23 22 21 20 19 18 17 16 15 14 13 12 11 10 9 8 7 6 5 4 3 2 1 0																														
ID	V U T S R Q P O N M L K J I H G F E D C B A																														
Reset 0x00000000	0 0																														
ID	R/W	Field	Value ID	Value	Description																										
			Set	1	Enable																										
			Disabled	0	Read: Disabled																										
			Enabled	1	Read: Enabled																										
T	RW	CH6LIMITL			Write '1' to enable interrupt for event CH6LIMITL																										
			Set	1	Enable																										
			Disabled	0	Read: Disabled																										
			Enabled	1	Read: Enabled																										
U	RW	CH7LIMITH			Write '1' to enable interrupt for event CH7LIMITH																										
			Set	1	Enable																										
			Disabled	0	Read: Disabled																										
			Enabled	1	Read: Enabled																										
V	RW	CH7LIMITL			Write '1' to enable interrupt for event CH7LIMITL																										
			Set	1	Enable																										
			Disabled	0	Read: Disabled																										
			Enabled	1	Read: Enabled																										

6.12.10.25 INTENCLR

Address offset: 0x308

Disable interrupt

Bit number	31 30 29 28 27 26 25 24 23 22 21 20 19 18 17 16 15 14 13 12 11 10 9 8 7 6 5 4 3 2 1 0																														
ID	V U T S R Q P O N M L K J I H G F E D C B A																														
Reset 0x00000000	0 0																														
ID	R/W	Field	Value ID	Value	Description																										
A	RW	STARTED			Write '1' to disable interrupt for event STARTED																										
			Clear	1	Disable																										
			Disabled	0	Read: Disabled																										
			Enabled	1	Read: Enabled																										
B	RW	END			Write '1' to disable interrupt for event END																										
			Clear	1	Disable																										
			Disabled	0	Read: Disabled																										
			Enabled	1	Read: Enabled																										
C	RW	DONE			Write '1' to disable interrupt for event DONE																										
			Clear	1	Disable																										
			Disabled	0	Read: Disabled																										
			Enabled	1	Read: Enabled																										
D	RW	RESULTDONE			Write '1' to disable interrupt for event RESULTDONE																										
			Clear	1	Disable																										
			Disabled	0	Read: Disabled																										
			Enabled	1	Read: Enabled																										
E	RW	CALIBRATEDONE			Write '1' to disable interrupt for event CALIBRATEDONE																										
			Clear	1	Disable																										
			Disabled	0	Read: Disabled																										
			Enabled	1	Read: Enabled																										
F	RW	STOPPED			Write '1' to disable interrupt for event STOPPED																										
			Clear	1	Disable																										
			Disabled	0	Read: Disabled																										
			Enabled	1	Read: Enabled																										

Bit number		31 30 29 28 27 26 25 24 23 22 21 20 19 18 17 16 15 14 13 12 11 10 9 8 7 6 5 4 3 2 1 0																											
ID		V U T S R Q P O N M L K J I H G F E D C B A																											
Reset 0x00000000		0 0																											
ID	R/W	Field	Value ID	Value	Description																								
G	RW	CH0LIMITH			Write '1' to disable interrupt for event CH0LIMITH																								
			Clear	1	Disable																								
			Disabled	0	Read: Disabled																								
			Enabled	1	Read: Enabled																								
H	RW	CH0LIMITL			Write '1' to disable interrupt for event CH0LIMITL																								
			Clear	1	Disable																								
			Disabled	0	Read: Disabled																								
			Enabled	1	Read: Enabled																								
I	RW	CH1LIMITH			Write '1' to disable interrupt for event CH1LIMITH																								
			Clear	1	Disable																								
			Disabled	0	Read: Disabled																								
			Enabled	1	Read: Enabled																								
J	RW	CH1LIMITL			Write '1' to disable interrupt for event CH1LIMITL																								
			Clear	1	Disable																								
			Disabled	0	Read: Disabled																								
			Enabled	1	Read: Enabled																								
K	RW	CH2LIMITH			Write '1' to disable interrupt for event CH2LIMITH																								
			Clear	1	Disable																								
			Disabled	0	Read: Disabled																								
			Enabled	1	Read: Enabled																								
L	RW	CH2LIMITL			Write '1' to disable interrupt for event CH2LIMITL																								
			Clear	1	Disable																								
			Disabled	0	Read: Disabled																								
			Enabled	1	Read: Enabled																								
M	RW	CH3LIMITH			Write '1' to disable interrupt for event CH3LIMITH																								
			Clear	1	Disable																								
			Disabled	0	Read: Disabled																								
			Enabled	1	Read: Enabled																								
N	RW	CH3LIMITL			Write '1' to disable interrupt for event CH3LIMITL																								
			Clear	1	Disable																								
			Disabled	0	Read: Disabled																								
			Enabled	1	Read: Enabled																								
O	RW	CH4LIMITH			Write '1' to disable interrupt for event CH4LIMITH																								
			Clear	1	Disable																								
			Disabled	0	Read: Disabled																								
			Enabled	1	Read: Enabled																								
P	RW	CH4LIMITL			Write '1' to disable interrupt for event CH4LIMITL																								
			Clear	1	Disable																								
			Disabled	0	Read: Disabled																								
			Enabled	1	Read: Enabled																								
Q	RW	CH5LIMITH			Write '1' to disable interrupt for event CH5LIMITH																								
			Clear	1	Disable																								
			Disabled	0	Read: Disabled																								
			Enabled	1	Read: Enabled																								
R	RW	CH5LIMITL			Write '1' to disable interrupt for event CH5LIMITL																								
			Clear	1	Disable																								
			Disabled	0	Read: Disabled																								
			Enabled	1	Read: Enabled																								
S	RW	CH6LIMITH			Write '1' to disable interrupt for event CH6LIMITH																								
			Clear	1	Disable																								

Bit number	31 30 29 28 27 26 25 24 23 22 21 20 19 18 17 16 15 14 13 12 11 10 9 8 7 6 5 4 3 2 1 0																														
ID	V U T S R Q P O N M L K J I H G F E D C B A																														
Reset	0x00000000																														
Reset	0 0																														
ID	R/W	Field	Value ID	Value	Description																										
			Disabled	0	Read: Disabled																										
			Enabled	1	Read: Enabled																										
T	RW	CH6LIMITL			Write '1' to disable interrupt for event CH6LIMITL																										
			Clear	1	Disable																										
			Disabled	0	Read: Disabled																										
			Enabled	1	Read: Enabled																										
U	RW	CH7LIMITH			Write '1' to disable interrupt for event CH7LIMITH																										
			Clear	1	Disable																										
			Disabled	0	Read: Disabled																										
			Enabled	1	Read: Enabled																										
V	RW	CH7LIMITL			Write '1' to disable interrupt for event CH7LIMITL																										
			Clear	1	Disable																										
			Disabled	0	Read: Disabled																										
			Enabled	1	Read: Enabled																										

6.12.10.26 STATUS

Address offset: 0x400

Status

Bit number	31 30 29 28 27 26 25 24 23 22 21 20 19 18 17 16 15 14 13 12 11 10 9 8 7 6 5 4 3 2 1 0																														
ID	A																														
Reset	0x00000000																														
Reset	0 0																														
ID	R/W	Field	Value ID	Value	Description																										
A	R	STATUS			Status																										
			Ready	0	ADC is ready. No on-going conversion.																										
			Busy	1	ADC is busy. Single conversion in progress.																										

6.12.10.27 ENABLE

Address offset: 0x500

Enable or disable ADC

Bit number	31 30 29 28 27 26 25 24 23 22 21 20 19 18 17 16 15 14 13 12 11 10 9 8 7 6 5 4 3 2 1 0																														
ID	A																														
Reset	0x00000000																														
Reset	0 0																														
ID	R/W	Field	Value ID	Value	Description																										
A	RW	ENABLE			Enable or disable ADC																										
			Disabled	0	Disable ADC																										
			Enabled	1	Enable ADC																										

When enabled, the ADC will acquire access to the analog input pins specified in the CH[n].PSEL0 and CH[n].PSEL1 registers.

6.12.10.28 CH[n].PSEL0 (n=0..7)

Address offset: 0x510 + (n × 0x10)

Input positive pin selection for CH[n]

Bit number	31 30 29 28 27 26 25 24 23 22 21 20 19 18 17 16 15 14 13 12 11 10 9 8 7 6 5 4 3 2 1 0																																		
ID																															A	A	A	A	A
Reset 0x00000000	0 0																																		
ID	R/W	Field	Value ID	Value	Description																														
A	RW	PSELP			Analog positive input channel																														
			NC	0	Not connected																														
			AnalogInput0	1	AIN0																														
			AnalogInput1	2	AIN1																														
			AnalogInput2	3	AIN2																														
			AnalogInput3	4	AIN3																														
			AnalogInput4	5	AIN4																														
			AnalogInput5	6	AIN5																														
			AnalogInput6	7	AIN6																														
			AnalogInput7	8	AIN7																														
			VDDGPIO	9	VDD_GPIO																														

6.12.10.29 CH[n].PSELN (n=0..7)

Address offset: 0x514 + (n × 0x10)

Input negative pin selection for CH[n]

Bit number	31 30 29 28 27 26 25 24 23 22 21 20 19 18 17 16 15 14 13 12 11 10 9 8 7 6 5 4 3 2 1 0																																		
ID																															A	A	A	A	A
Reset 0x00000000	0 0																																		
ID	R/W	Field	Value ID	Value	Description																														
A	RW	PSELN			Analog negative input, enables differential channel																														
			NC	0	Not connected																														
			AnalogInput0	1	AIN0																														
			AnalogInput1	2	AIN1																														
			AnalogInput2	3	AIN2																														
			AnalogInput3	4	AIN3																														
			AnalogInput4	5	AIN4																														
			AnalogInput5	6	AIN5																														
			AnalogInput6	7	AIN6																														
			AnalogInput7	8	AIN7																														
			VDD_GPIO	9	VDD_GPIO																														

6.12.10.30 CH[n].CONFIG (n=0..7)

Address offset: 0x518 + (n × 0x10)

Input configuration for CH[n]

Bit number	31 30 29 28 27 26 25 24 23 22 21 20 19 18 17 16 15 14 13 12 11 10 9 8 7 6 5 4 3 2 1 0																																								
ID											G	F			E			E			D			C			C			B			B			A			A		
Reset 0x00020000	0 0																																								
ID	R/W	Field	Value ID	Value	Description																																				
A	RW	RESP			Positive channel resistor control																																				
			Bypass	0	Bypass resistor ladder																																				
			Pulldown	1	Pull-down to GND																																				
			Pullup	2	Pull-up to VDD_GPIO																																				
			VDD1_2	3	Set input at VDD_GPIO/2																																				
B	RW	RESN			Negative channel resistor control																																				
			Bypass	0	Bypass resistor ladder																																				

Bit number																															
31	30	29	28	27	26	25	24	23	22	21	20	19	18	17	16	15	14	13	12	11	10	9	8	7	6	5	4	3	2	1	0
ID	G										F			E			D			C			B			A					
Reset 0x00020000	0 0 0 0 0 0 0 0 0 0 0 0 0 0 0 0 1 0 0 0 0 0 0 0 0 0 0 0 0 0 0 0 0 0																														
ID	R/W	Field	Value ID	Value	Description																										
			Pulldown	1	Pull-down to GND																										
			Pullup	2	Pull-up to VDD_GPIO																										
			VDD1_2	3	Set input at VDD_GPIO/2																										
C	RW	GAIN			Gain control																										
			Gain1_6	0	1/6																										
			Gain1_5	1	1/5																										
			Gain1_4	2	1/4																										
			Gain1_3	3	1/3																										
			Gain1_2	4	1/2																										
			Gain1	5	1																										
			Gain2	6	2																										
			Gain4	7	4																										
D-	RW	REFSEL			Reference control																										
			Internal	0	Internal reference (0.6 V)																										
			VDD1_4	1	VDD_GPIO/4 as reference																										
E	RW	TACQ			Acquisition time, the time the ADC uses to sample the input voltage																										
			3us	0	3 us																										
			5us	1	5 us																										
			10us	2	10 us																										
			15us	3	15 us																										
			20us	4	20 us																										
			40us	5	40 us																										
F	RW	MODE			Enable differential mode																										
			SE	0	Single ended, PSELN will be ignored, negative input to ADC shorted to GND																										
			Diff	1	Differential																										
G	RW	BURST			Enable burst mode																										
			Disabled	0	Burst mode is disabled (normal operation)																										
			Enabled	1	Burst mode is enabled. SAADC takes 2 ^{OVERSAMPLE} number of samples as fast as it can, and sends the average to Data RAM.																										

6.12.10.31 CH[n].LIMIT (n=0..7)

Address offset: 0x51C + (n × 0x10)

High/low limits for event monitoring a channel

Bit number																															
31	30	29	28	27	26	25	24	23	22	21	20	19	18	17	16	15	14	13	12	11	10	9	8	7	6	5	4	3	2	1	0
ID	B										B			B			B			B			A			A					
Reset 0x7FFF8000	0 1 1 1 1 1 1 1 1 1 1 1 1 1 1 1 1 0 0 0 0 0 0 0 0 0 0 0 0 0 0 0 0																														
ID	R/W	Field	Value ID	Value	Description																										
A	RW	LOW		[-32768 to +32767]	Low level limit																										
B	RW	HIGH		[-32768 to +32767]	High level limit																										

6.12.10.32 RESOLUTION

Address offset: 0x5F0

Resolution configuration

Bit number	31	30	29	28	27	26	25	24	23	22	21	20	19	18	17	16	15	14	13	12	11	10	9	8	7	6	5	4	3	2	1	0
ID																											A	A	A			
Reset	0x00000001																															
Reset	0	0	0	0	0	0	0	0	0	0	0	0	0	0	0	0	0	0	0	0	0	0	0	0	0	0	0	0	0	0	1	
ID	R/W	Field	Value ID	Value	Description																											
A	RW	VAL			Set the resolution																											
			8bit	0	8 bit																											
			10bit	1	10 bit																											
			12bit	2	12 bit																											
			14bit	3	14 bit																											

6.12.10.33 OVERSAMPLE

Address offset: 0x5F4

Oversampling configuration. OVERSAMPLE should not be combined with SCAN. The RESOLUTION is applied before averaging, thus for high OVERSAMPLE a higher RESOLUTION should be used.

Bit number	31	30	29	28	27	26	25	24	23	22	21	20	19	18	17	16	15	14	13	12	11	10	9	8	7	6	5	4	3	2	1	0
ID																											A	A	A	A		
Reset	0x00000000																															
Reset	0	0	0	0	0	0	0	0	0	0	0	0	0	0	0	0	0	0	0	0	0	0	0	0	0	0	0	0	0	0	0	
ID	R/W	Field	Value ID	Value	Description																											
A	RW	OVERSAMPLE			Oversample control																											
			Bypass	0	Bypass oversampling																											
			Over2x	1	Oversample 2x																											
			Over4x	2	Oversample 4x																											
			Over8x	3	Oversample 8x																											
			Over16x	4	Oversample 16x																											
			Over32x	5	Oversample 32x																											
			Over64x	6	Oversample 64x																											
			Over128x	7	Oversample 128x																											
			Over256x	8	Oversample 256x																											

6.12.10.34 SAMPLERATE

Address offset: 0x5F8

Controls normal or continuous sample rate

Bit number	31	30	29	28	27	26	25	24	23	22	21	20	19	18	17	16	15	14	13	12	11	10	9	8	7	6	5	4	3	2	1	0																							
ID																											B	A	A	A	A	A	A	A	A	A	A	A	A	A	A	A	A	A	A	A	A	A	A	A	A	A	A	A	A
Reset	0x00000000																																																						
Reset	0	0	0	0	0	0	0	0	0	0	0	0	0	0	0	0	0	0	0	0	0	0	0	0	0	0	0	0	0	0	0																								
ID	R/W	Field	Value ID	Value	Description																																																		
A	RW	CC		[80..2047]	Capture and compare value. Sample rate is 16 MHz/CC																																																		
B	RW	MODE			Select mode for sample rate control																																																		
			Task	0	Rate is controlled from SAMPLE task																																																		
			Timers	1	Rate is controlled from local timer (use CC to control the rate)																																																		

6.12.10.35 RESULT

RESULT EasyDMA channel

6.12.10.35.1 RESULT.PTR

Address offset: 0x62C

Data pointer

Bit number	31	30	29	28	27	26	25	24	23	22	21	20	19	18	17	16	15	14	13	12	11	10	9	8	7	6	5	4	3	2	1	0	
ID	A	A	A	A	A	A	A	A	A	A	A	A	A	A	A	A	A	A	A	A	A	A	A	A	A	A	A	A	A	A	A	A	A
Reset 0x00000000	0	0	0	0	0	0	0	0	0	0	0	0	0	0	0	0	0	0	0	0	0	0	0	0	0	0	0	0	0	0	0	0	
ID	R/W	Field	Value ID	Value	Description																												
A	RW	PTR			Data pointer																												

Note: See the memory chapter for details about which memories are available for EasyDMA.

6.12.10.35.2 RESULT.MAXCNT

Address offset: 0x630

Maximum number of buffer words to transfer

Bit number	31	30	29	28	27	26	25	24	23	22	21	20	19	18	17	16	15	14	13	12	11	10	9	8	7	6	5	4	3	2	1	0
ID																					A	A	A	A	A	A	A	A	A	A	A	A
Reset 0x00000000	0	0	0	0	0	0	0	0	0	0	0	0	0	0	0	0	0	0	0	0	0	0	0	0	0	0	0	0	0	0	0	
ID	R/W	Field	Value ID	Value	Description																											
A	RW	MAXCNT			Maximum number of buffer words to transfer																											

6.12.10.35.3 RESULT.AMOUNT

Address offset: 0x634

Number of buffer words transferred since last START

Bit number	31	30	29	28	27	26	25	24	23	22	21	20	19	18	17	16	15	14	13	12	11	10	9	8	7	6	5	4	3	2	1	0
ID																					A	A	A	A	A	A	A	A	A	A	A	A
Reset 0x00000000	0	0	0	0	0	0	0	0	0	0	0	0	0	0	0	0	0	0	0	0	0	0	0	0	0	0	0	0	0	0	0	
ID	R/W	Field	Value ID	Value	Description																											
A	R	AMOUNT			Number of buffer words transferred since last START. This register can be read after an END or STOPPED event.																											

6.12.11 Electrical specification

6.12.11.1 SAADC Electrical Specification

Symbol	Description	Min.	Typ.	Max.	Units
DNL ₁₀	Differential non-linearity, 10-bit resolution	-0.95	<1		LSB10b
INL ₁₀	Integral non-linearity, 10-bit resolution		1		LSB10b
V _{OS}	Differential offset error (calibrated), 10-bit resolution ^a		±2		LSB10b
C _{EG}	Gain error temperature coefficient	-0.05	0.02	0.05	%/°C
f _{SAMPLE}	Maximum sampling rate			200	kHz
t _{ACQ,10k}	Acquisition time (configurable), source Resistance ≤ 10 kOhm		3		μs
t _{ACQ,40k}	Acquisition time (configurable), source Resistance ≤ 40 kOhm		5		μs
t _{ACQ,100k}	Acquisition time (configurable), source Resistance ≤ 100 kOhm		10		μs
t _{ACQ,200k}	Acquisition time (configurable), source Resistance ≤ 200 kOhm		15		μs
t _{ACQ,400k}	Acquisition time (configurable), source Resistance ≤ 400 kOhm		20		μs
t _{ACQ,800k}	Acquisition time (configurable), source Resistance ≤ 800 kOhm		40		μs
t _{CONV}	Conversion time		<2		μs

^a Digital output code at zero volt differential input.

Symbol	Description	Min.	Typ.	Max.	Units
E _{G1/6}	Error ^b for Gain = 1/6	-3		3	%
E _{G1/4}	Error ^b for Gain = 1/4	-3		3	%
E _{G1/2}	Error ^b for Gain = 1/2. Internal reference	-3		4	%
E _{G1}	Error ^b for Gain = 1. Internal reference	-3		4	%
E _{G1/2_VDD_GPIO}	Error ^b for Gain = 1/2. VDD_GPIO as reference	-4		4	%
E _{G1_VDD_GPIO}	Error ^b for Gain = 1. VDD_GPIO as reference	-4		4	%
C _{SAMPLE}	Sample and hold capacitance at maximum gain ¹⁴		2.5		pF
R _{INPUT}	Input resistance		>1		MΩ
E _{NOB}	Effective number of bits, differential mode, 12-bit resolution, 1/1 gain, 3 μs acquisition time, HFXO, 200 ksps		9		Bit
S _{NDR}	Peak signal to noise and distortion ratio, differential mode, 12-bit resolution, 1/1 gain, 3 μs acquisition time, HFXO, 200 ksps		56		dB
S _{FDR}	Spurious free dynamic range, differential mode, 12-bit resolution, 1/1 gain, 3 μs acquisition time, HFXO, 200 ksps		70		dBc
R _{LADDER}	Ladder resistance		160		kΩ

6.12.12 Performance factors

Clock jitter, affecting sample timing accuracy, and circuit noise can affect ADC performance.

Jitter can be between START tasks or from START task to acquisition. START timer accuracy and startup times of regulators and references will contribute to variability. Sources of circuit noise may include CPU activity and the DC/DC regulator. Best ADC performance is achieved using START timing based on the TIMER module, HFXO clock source, and Constant Latency mode.

6.13 SPIM — Serial peripheral interface master with EasyDMA

The SPI master can communicate with multiple slaves using individual chip select signals for each of the slave devices attached to a bus.

Listed here are the main features for the SPIM

- SPI mode 0-3
- EasyDMA direct transfer to/from RAM for both SPI Slave and SPI Master
- Individual selection of IO pin for each SPI signal

^b Does not include temperature drift

¹⁴ Maximum gain corresponds to highest capacitance.

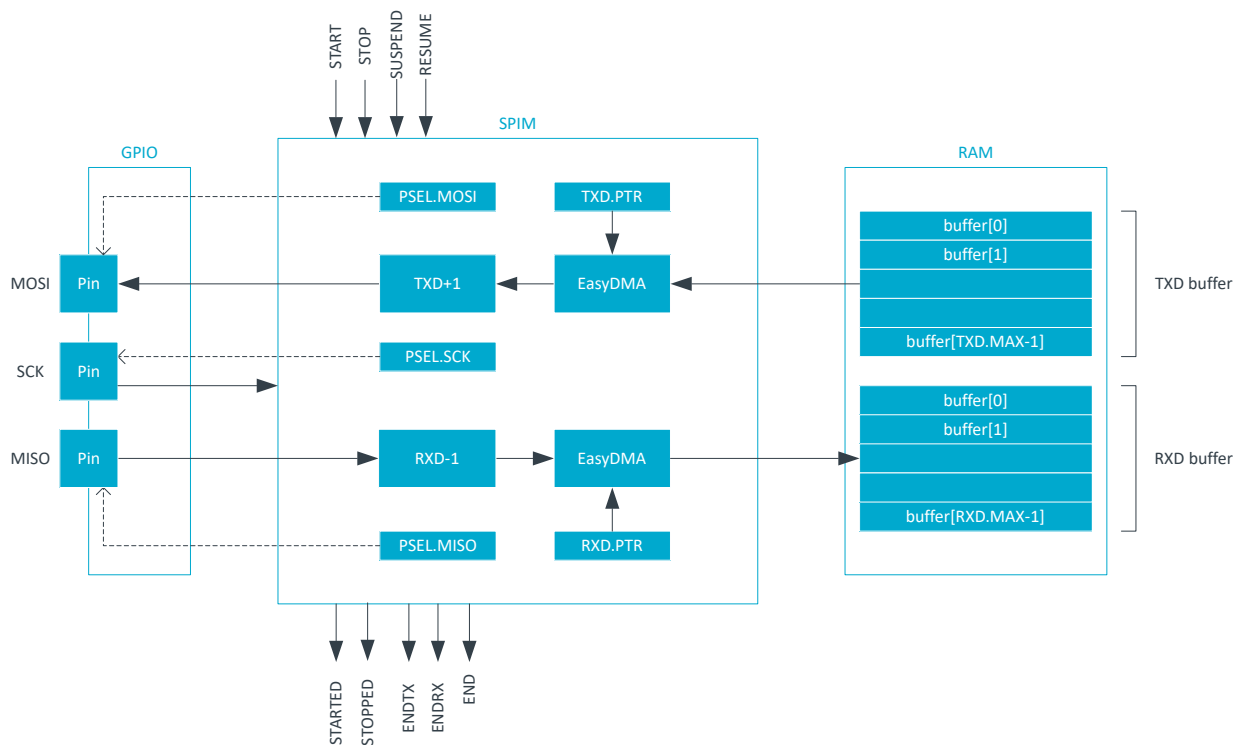

Figure 77: SPIM — SPI master with EasyDMA

The SPIM does not implement support for chip select directly. Therefore, the CPU must use available GPIOs to select the correct slave and control this independently of the SPI master. The SPIM supports SPI modes 0 through 3. The CONFIG register allows setting CPOL and CPHA appropriately.

Mode	Clock polarity	Clock phase
	CPOL	CPHA
SPI_MODE0	0 (Active High)	0 (Leading)
SPI_MODE1	0 (Active High)	1 (Trailing)
SPI_MODE2	1 (Active Low)	0 (Leading)
SPI_MODE3	1 (Active Low)	1 (Trailing)

Table 33: SPI modes

6.13.1 SPI master transaction sequence

An SPI master transaction consists of a sequence started by the START task followed by a number of events, and finally the STOP task.

An SPI master transaction is started by triggering the START task. The ENDTX event will be generated when the transmitter has transmitted all bytes in the TXD buffer as specified in the TXD.MAXCNT register. The ENDRX event will be generated when the receiver has filled the RXD buffer, i.e. received the last possible byte as specified in the RXD.MAXCNT register.

Following a START task, the SPI master will generate an END event when both ENDRX and ENDTX have been generated.

The SPI master is stopped by triggering the STOP task. A STOPPED event is generated when the SPI master has stopped.

If the ENDRX event has not already been generated when the SPI master has come to a stop, the SPI master will generate the ENDRX event explicitly even though the RX buffer is not full.

If the ENDTX event has not already been generated when the SPI master has come to a stop, the SPI master will generate the ENDTX event explicitly even though all bytes in the TXD buffer, as specified in the TXD.MAXCNT register, have not been transmitted.

The SPI master is a synchronous interface, and for every byte that is sent, a different byte will be received at the same time; this is illustrated in [SPI master transaction](#) on page 294.

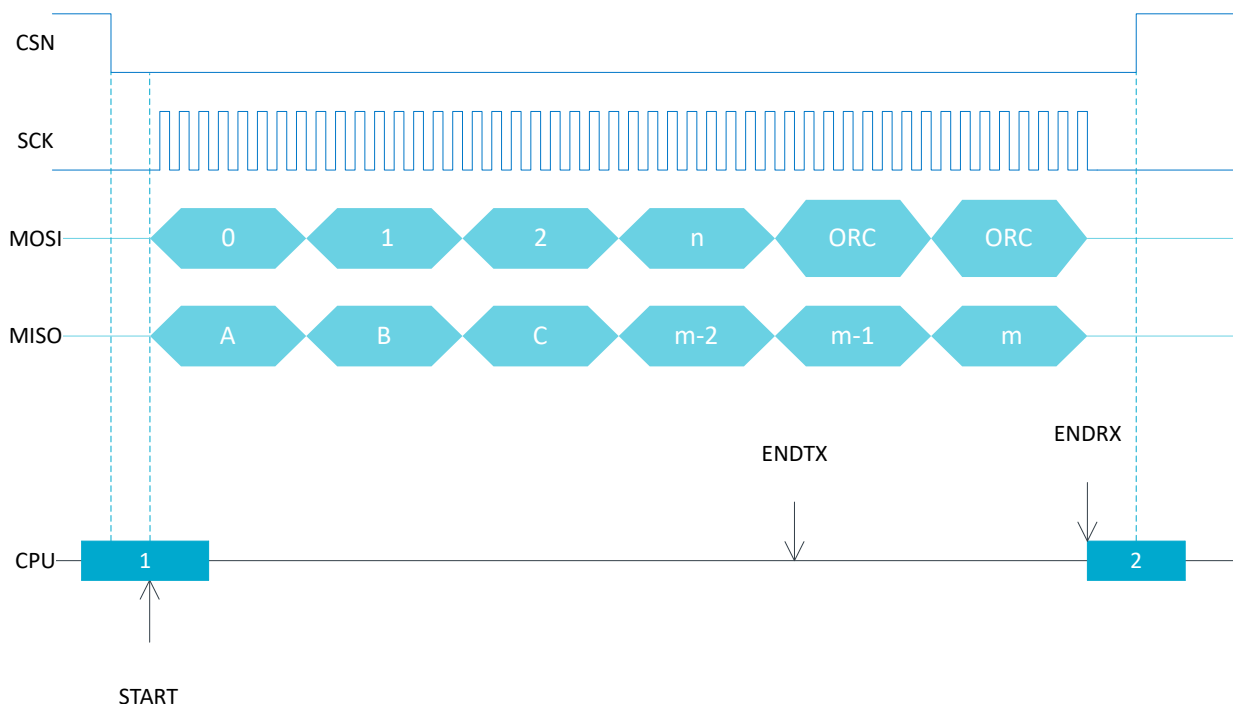

Figure 78: SPI master transaction

6.13.2 Master mode pin configuration

The SCK, MOSI, and MISO signals associated with the SPI master are mapped to physical pins according to the configuration specified in the PSEL.SCK, PSEL.MOSI, and PSEL.MISO registers respectively.

The PSEL.SCK, PSEL.MOSI, and PSEL.MISO registers and their configurations are only used as long as the SPI master is enabled, and retained only as long as the device is in ON mode. PSEL.SCK, PSEL.MOSI and PSEL.MISO must only be configured when the SPI master is disabled.

To secure correct behavior in the SPI, the pins used by the SPI must be configured in the GPIO peripheral as described in [GPIO configuration](#) on page 294 prior to enabling the SPI. This configuration must be retained in the GPIO for the selected IOs as long as the SPI is enabled.

Only one peripheral can be assigned to drive a particular GPIO pin at a time. Failing to do so may result in unpredictable behavior.

SPI master signal	SPI master pin	Direction	Output value
SCK	As specified in PSEL.SCK	Output	Same as CONFIG.CPOL
MOSI	As specified in PSEL.MOSI	Output	0
MISO	As specified in PSEL.MISO	Input	Not applicable

Table 34: GPIO configuration

6.13.3 Shared resources

The SPI shares registers and other resources with other peripherals that have the same ID as the SPI. Therefore, the user must disable all peripherals that have the same ID as the SPI before the SPI can be configured and used.

Disabling a peripheral that has the same ID as the SPI will not reset any of the registers that are shared with the SPI. It is therefore important to configure all relevant SPI registers explicitly to secure that it operates correctly.

See the Instantiation table in [Instantiation](#) on page 27 for details on peripherals and their IDs.

6.13.4 EasyDMA

The SPIM implements EasyDMA for accessing RAM without CPU involvement.

The SPIM peripheral implements the following EasyDMA channels:

Channel	Type	Register Cluster
TXD	READER	TXD
RXD	WRITER	RXD

Table 35: SPIM EasyDMA Channels

For detailed information regarding the use of EasyDMA, see [EasyDMA](#) on page 48.

The .PTR and .MAXCNT registers are double-buffered. They can be updated and prepared for the next transmission immediately after having received the STARTED event.

The SPI master will automatically stop transmitting after TXD.MAXCNT bytes have been transmitted and RXD.MAXCNT bytes have been received. If RXD.MAXCNT is larger than TXD.MAXCNT, the remaining transmitted bytes will contain the value defined in the ORC register. If TXD.MAXCNT is larger than RXD.MAXCNT, the superfluous received bytes will be discarded.

The ENDRX/ENDTX event indicate that EasyDMA has finished accessing respectively the RX/TX buffer in RAM. The END event gets generated when both RX and TX are finished accessing the buffers in RAM.

In the case of bus congestion as described in [AHB multilayer interconnect](#) on page 50, data loss may occur.

6.13.5 Low power

When putting the system in low power and the peripheral is not needed, lowest possible power consumption is achieved by stopping, and then disabling the peripheral.

The STOP task may not be always needed (the peripheral might already be stopped), but if it is sent, software shall wait until the STOPPED event was received as a response before disabling the peripheral through the ENABLE register.

6.13.6 Registers

Instances

Instance	Base address	TrustZone			Split access	Description
		Map	Att	DMA		
SPIM0 : S	0x50008000	US	NS	SA	No	SPI master 0
SPIM0 : NS	0x40008000					
SPIM1 : S	0x50009000	US	NS	SA	No	SPI master 1
SPIM1 : NS	0x40009000					
SPIM2 : S	0x5000A000	US	NS	SA	No	SPI master 2
SPIM2 : NS	0x4000A000					
SPIM3 : S	0x5000B000	US	NS	SA	No	SPI master 3
SPIM3 : NS	0x4000B000					

Register overview

Register	Offset	TZ	Description
TASKS_START	0x010		Start SPI transaction
TASKS_STOP	0x014		Stop SPI transaction
TASKS_SUSPEND	0x01C		Suspend SPI transaction
TASKS_RESUME	0x020		Resume SPI transaction
SUBSCRIBE_START	0x090		Subscribe configuration for task START
SUBSCRIBE_STOP	0x094		Subscribe configuration for task STOP
SUBSCRIBE_SUSPEND	0x09C		Subscribe configuration for task SUSPEND
SUBSCRIBE_RESUME	0x0A0		Subscribe configuration for task RESUME
EVENTS_STOPPED	0x104		SPI transaction has stopped
EVENTS_ENDRX	0x110		End of RXD buffer reached
EVENTS_END	0x118		End of RXD buffer and TXD buffer reached
EVENTS_ENDTX	0x120		End of TXD buffer reached
EVENTS_STARTED	0x14C		Transaction started
PUBLISH_STOPPED	0x184		Publish configuration for event STOPPED
PUBLISH_ENDRX	0x190		Publish configuration for event ENDRX
PUBLISH_END	0x198		Publish configuration for event END
PUBLISH_ENDTX	0x1A0		Publish configuration for event ENDTX
PUBLISH_STARTED	0x1CC		Publish configuration for event STARTED
SHORTS	0x200		Shortcuts between local events and tasks
INTENSET	0x304		Enable interrupt
INTENCLR	0x308		Disable interrupt
ENABLE	0x500		Enable SPIM
PSEL.SCK	0x508		Pin select for SCK
PSEL.MOSI	0x50C		Pin select for MOSI signal
PSEL.MISO	0x510		Pin select for MISO signal
FREQUENCY	0x524		SPI frequency. Accuracy depends on the HFCLK source selected.
RXD.PTR	0x534		Data pointer
RXD.MAXCNT	0x538		Maximum number of bytes in receive buffer
RXD.AMOUNT	0x53C		Number of bytes transferred in the last transaction
RXD.LIST	0x540		EasyDMA list type
TXD.PTR	0x544		Data pointer
TXD.MAXCNT	0x548		Maximum number of bytes in transmit buffer
TXD.AMOUNT	0x54C		Number of bytes transferred in the last transaction
TXD.LIST	0x550		EasyDMA list type

Register	Offset	TZ	Description
CONFIG	0x554		Configuration register
ORC	0x5C0		Over-read character. Character clocked out in case an over-read of the TXD buffer.

6.13.6.1 TASKS_START

Address offset: 0x010

Start SPI transaction

Bit number	31	30	29	28	27	26	25	24	23	22	21	20	19	18	17	16	15	14	13	12	11	10	9	8	7	6	5	4	3	2	1	0
ID																												A				
Reset 0x00000000	0 0																															
ID	R/W	Field	Value ID	Value	Description																											
A	W	TASKS_START			Start SPI transaction																											
			Trigger	1	Trigger task																											

6.13.6.2 TASKS_STOP

Address offset: 0x014

Stop SPI transaction

Bit number	31	30	29	28	27	26	25	24	23	22	21	20	19	18	17	16	15	14	13	12	11	10	9	8	7	6	5	4	3	2	1	0
ID																												A				
Reset 0x00000000	0 0																															
ID	R/W	Field	Value ID	Value	Description																											
A	W	TASKS_STOP			Stop SPI transaction																											
			Trigger	1	Trigger task																											

6.13.6.3 TASKS_SUSPEND

Address offset: 0x01C

Suspend SPI transaction

Bit number	31	30	29	28	27	26	25	24	23	22	21	20	19	18	17	16	15	14	13	12	11	10	9	8	7	6	5	4	3	2	1	0
ID																												A				
Reset 0x00000000	0 0																															
ID	R/W	Field	Value ID	Value	Description																											
A	W	TASKS_SUSPEND			Suspend SPI transaction																											
			Trigger	1	Trigger task																											

6.13.6.4 TASKS_RESUME

Address offset: 0x020

Resume SPI transaction

Bit number	31	30	29	28	27	26	25	24	23	22	21	20	19	18	17	16	15	14	13	12	11	10	9	8	7	6	5	4	3	2	1	0
ID																												A				
Reset 0x00000000	0 0																															
ID	R/W	Field	Value ID	Value	Description																											
A	W	TASKS_RESUME			Resume SPI transaction																											
			Trigger	1	Trigger task																											

6.13.6.5 SUBSCRIBE_START

Address offset: 0x090

Subscribe configuration for task **START**

Bit number	31 30 29 28 27 26 25 24 23 22 21 20 19 18 17 16 15 14 13 12 11 10 9 8 7 6 5 4 3 2 1 0																														
ID	B																								A A A A A A A						
Reset 0x00000000	0 0																														
ID	R/W	Field	Value ID	Value	Description																										
A	RW	CHIDX		[0..255]	DPPI channel that task START will subscribe to																										
B	RW	EN	Disabled	0	Disable subscription																										
			Enabled	1	Enable subscription																										

6.13.6.6 SUBSCRIBE_STOP

Address offset: 0x094

Subscribe configuration for task **STOP**

Bit number	31 30 29 28 27 26 25 24 23 22 21 20 19 18 17 16 15 14 13 12 11 10 9 8 7 6 5 4 3 2 1 0																														
ID	B																								A A A A A A A						
Reset 0x00000000	0 0																														
ID	R/W	Field	Value ID	Value	Description																										
A	RW	CHIDX		[0..255]	DPPI channel that task STOP will subscribe to																										
B	RW	EN	Disabled	0	Disable subscription																										
			Enabled	1	Enable subscription																										

6.13.6.7 SUBSCRIBE_SUSPEND

Address offset: 0x09C

Subscribe configuration for task **SUSPEND**

Bit number	31 30 29 28 27 26 25 24 23 22 21 20 19 18 17 16 15 14 13 12 11 10 9 8 7 6 5 4 3 2 1 0																														
ID	B																								A A A A A A A						
Reset 0x00000000	0 0																														
ID	R/W	Field	Value ID	Value	Description																										
A	RW	CHIDX		[0..255]	DPPI channel that task SUSPEND will subscribe to																										
B	RW	EN	Disabled	0	Disable subscription																										
			Enabled	1	Enable subscription																										

6.13.6.8 SUBSCRIBE_RESUME

Address offset: 0x0A0

Subscribe configuration for task **RESUME**

Bit number	31	30	29	28	27	26	25	24	23	22	21	20	19	18	17	16	15	14	13	12	11	10	9	8	7	6	5	4	3	2	1	0
ID	B																															
Reset 0x00000000	0 0																															
ID	R/W	Field	Value ID	Value	Description																											
A	RW	CHIDX		[0..255]	DPPI channel that task RESUME will subscribe to																											
B	RW	EN	Disabled	0	Disable subscription																											
			Enabled	1	Enable subscription																											

6.13.6.9 EVENTS_STOPPED

Address offset: 0x104

SPI transaction has stopped

Bit number	31	30	29	28	27	26	25	24	23	22	21	20	19	18	17	16	15	14	13	12	11	10	9	8	7	6	5	4	3	2	1	0
ID	A																															
Reset 0x00000000	0 0																															
ID	R/W	Field	Value ID	Value	Description																											
A	RW	EVENTS_STOPPED			SPI transaction has stopped																											
			NotGenerated	0	Event not generated																											
			Generated	1	Event generated																											

6.13.6.10 EVENTS_ENDRX

Address offset: 0x110

End of RXD buffer reached

Bit number	31	30	29	28	27	26	25	24	23	22	21	20	19	18	17	16	15	14	13	12	11	10	9	8	7	6	5	4	3	2	1	0
ID	A																															
Reset 0x00000000	0 0																															
ID	R/W	Field	Value ID	Value	Description																											
A	RW	EVENTS_ENDRX			End of RXD buffer reached																											
			NotGenerated	0	Event not generated																											
			Generated	1	Event generated																											

6.13.6.11 EVENTS_END

Address offset: 0x118

End of RXD buffer and TXD buffer reached

Bit number	31	30	29	28	27	26	25	24	23	22	21	20	19	18	17	16	15	14	13	12	11	10	9	8	7	6	5	4	3	2	1	0
ID	A																															
Reset 0x00000000	0 0																															
ID	R/W	Field	Value ID	Value	Description																											
A	RW	EVENTS_END			End of RXD buffer and TXD buffer reached																											
			NotGenerated	0	Event not generated																											
			Generated	1	Event generated																											

6.13.6.12 EVENTS_ENDTX

Address offset: 0x120

End of TXD buffer reached

Bit number	31	30	29	28	27	26	25	24	23	22	21	20	19	18	17	16	15	14	13	12	11	10	9	8	7	6	5	4	3	2	1	0
ID	A																															
Reset 0x00000000	0 0																															
ID	R/W	Field	Value ID	Value	Description																											
A	RW	EVENTS_ENDTX			End of TXD buffer reached																											
			NotGenerated	0	Event not generated																											
			Generated	1	Event generated																											

6.13.6.13 EVENTS_STARTED

Address offset: 0x14C

Transaction started

Bit number	31	30	29	28	27	26	25	24	23	22	21	20	19	18	17	16	15	14	13	12	11	10	9	8	7	6	5	4	3	2	1	0
ID	A																															
Reset 0x00000000	0 0																															
ID	R/W	Field	Value ID	Value	Description																											
A	RW	EVENTS_STARTED			Transaction started																											
			NotGenerated	0	Event not generated																											
			Generated	1	Event generated																											

6.13.6.14 PUBLISH_STOPPED

Address offset: 0x184

Publish configuration for event STOPPED

Bit number	31	30	29	28	27	26	25	24	23	22	21	20	19	18	17	16	15	14	13	12	11	10	9	8	7	6	5	4	3	2	1	0
ID	B															A A A A A A A A A A A A A A A A																
Reset 0x00000000	0 0																															
ID	R/W	Field	Value ID	Value	Description																											
A	RW	CHIDX		[0..255]	DPPI channel that event STOPPED will publish to																											
B	RW	EN																														
			Disabled	0	Disable publishing																											
			Enabled	1	Enable publishing																											

6.13.6.15 PUBLISH_ENDRX

Address offset: 0x190

Publish configuration for event ENDRX

Bit number	31	30	29	28	27	26	25	24	23	22	21	20	19	18	17	16	15	14	13	12	11	10	9	8	7	6	5	4	3	2	1	0
ID	B															A A A A A A A A A A A A A A A A																
Reset 0x00000000	0 0																															
ID	R/W	Field	Value ID	Value	Description																											
A	RW	CHIDX		[0..255]	DPPI channel that event ENDRX will publish to																											
B	RW	EN																														
			Disabled	0	Disable publishing																											
			Enabled	1	Enable publishing																											

6.13.6.16 PUBLISH_END

Address offset: 0x198

Publish configuration for event **END**

Bit number	31 30 29 28 27 26 25 24 23 22 21 20 19 18 17 16 15 14 13 12 11 10 9 8 7 6 5 4 3 2 1 0																															
ID	B															A A A A A A A A																
Reset 0x00000000	0 0																															
ID	R/W	Field	Value ID	Value	Description																											
A	RW	CHIDX		[0..255]	DPPI channel that event END will publish to																											
B	RW	EN	Disabled	0	Disable publishing																											
			Enabled	1	Enable publishing																											

6.13.6.17 PUBLISH_ENDTX

Address offset: 0x1A0

Publish configuration for event **ENDTX**

Bit number	31 30 29 28 27 26 25 24 23 22 21 20 19 18 17 16 15 14 13 12 11 10 9 8 7 6 5 4 3 2 1 0																															
ID	B															A A A A A A A A																
Reset 0x00000000	0 0																															
ID	R/W	Field	Value ID	Value	Description																											
A	RW	CHIDX		[0..255]	DPPI channel that event ENDTX will publish to																											
B	RW	EN	Disabled	0	Disable publishing																											
			Enabled	1	Enable publishing																											

6.13.6.18 PUBLISH_STARTED

Address offset: 0x1CC

Publish configuration for event **STARTED**

Bit number	31 30 29 28 27 26 25 24 23 22 21 20 19 18 17 16 15 14 13 12 11 10 9 8 7 6 5 4 3 2 1 0																															
ID	B															A A A A A A A A																
Reset 0x00000000	0 0																															
ID	R/W	Field	Value ID	Value	Description																											
A	RW	CHIDX		[0..255]	DPPI channel that event STARTED will publish to																											
B	RW	EN	Disabled	0	Disable publishing																											
			Enabled	1	Enable publishing																											

6.13.6.19 SHORTS

Address offset: 0x200

Shortcuts between local events and tasks

Bit number	31 30 29 28 27 26 25 24 23 22 21 20 19 18 17 16 15 14 13 12 11 10 9 8 7 6 5 4 3 2 1 0																															
ID	A																															
Reset 0x00000000	0 0																															
ID	R/W	Field	Value ID	Value	Description																											
A	RW	END_START			Shortcut between event END and task START																											
			Disabled	0	Disable shortcut																											
			Enabled	1	Enable shortcut																											

6.13.6.20 INTENSET

Address offset: 0x304

Enable interrupt

Bit number	31 30 29 28 27 26 25 24 23 22 21 20 19 18 17 16 15 14 13 12 11 10 9 8 7 6 5 4 3 2 1 0																														
ID	E															D			C		B		A								
Reset 0x00000000	0 0																														
ID	R/W	Field	Value ID	Value	Description																										
A	RW	STOPPED			Write '1' to enable interrupt for event STOPPED																										
			Set	1	Enable																										
			Disabled	0	Read: Disabled																										
			Enabled	1	Read: Enabled																										
B	RW	ENDRX			Write '1' to enable interrupt for event ENDRX																										
			Set	1	Enable																										
			Disabled	0	Read: Disabled																										
			Enabled	1	Read: Enabled																										
C	RW	END			Write '1' to enable interrupt for event END																										
			Set	1	Enable																										
			Disabled	0	Read: Disabled																										
			Enabled	1	Read: Enabled																										
D	RW	ENDTX			Write '1' to enable interrupt for event ENDTX																										
			Set	1	Enable																										
			Disabled	0	Read: Disabled																										
			Enabled	1	Read: Enabled																										
E	RW	STARTED			Write '1' to enable interrupt for event STARTED																										
			Set	1	Enable																										
			Disabled	0	Read: Disabled																										
			Enabled	1	Read: Enabled																										

6.13.6.21 INTENCLR

Address offset: 0x308

Disable interrupt

Bit number	31 30 29 28 27 26 25 24 23 22 21 20 19 18 17 16 15 14 13 12 11 10 9 8 7 6 5 4 3 2 1 0																														
ID	E															D			C		B		A								
Reset 0x00000000	0 0																														
ID	R/W	Field	Value ID	Value	Description																										
A	RW	STOPPED			Write '1' to disable interrupt for event STOPPED																										
			Clear	1	Disable																										
			Disabled	0	Read: Disabled																										
			Enabled	1	Read: Enabled																										
B	RW	ENDRX			Write '1' to disable interrupt for event ENDRX																										
			Clear	1	Disable																										
			Disabled	0	Read: Disabled																										
			Enabled	1	Read: Enabled																										
C	RW	END			Write '1' to disable interrupt for event END																										
			Clear	1	Disable																										
			Disabled	0	Read: Disabled																										
			Enabled	1	Read: Enabled																										
D	RW	ENDTX			Write '1' to disable interrupt for event ENDTX																										
			Clear	1	Disable																										

Bit number	31	30	29	28	27	26	25	24	23	22	21	20	19	18	17	16	15	14	13	12	11	10	9	8	7	6	5	4	3	2	1	0		
ID	E																D			C	B		A											
Reset 0x00000000	0 0																																	
ID	R/W	Field	Value ID	Value	Description																													
			Disabled	0	Read: Disabled																													
			Enabled	1	Read: Enabled																													
E	RW	STARTED			Write '1' to disable interrupt for event STARTED																													
			Clear	1	Disable																													
			Disabled	0	Read: Disabled																													
			Enabled	1	Read: Enabled																													

6.13.6.22 ENABLE

Address offset: 0x500

Enable SPIM

Bit number	31	30	29	28	27	26	25	24	23	22	21	20	19	18	17	16	15	14	13	12	11	10	9	8	7	6	5	4	3	2	1	0												
ID																													A			A	A	A										
Reset 0x00000000	0 0																																											
ID	R/W	Field	Value ID	Value	Description																																							
A	RW	ENABLE			Enable or disable SPIM																																							
			Disabled	0	Disable SPIM																																							
			Enabled	7	Enable SPIM																																							

6.13.6.23 PSEL.SCK

Address offset: 0x508

Pin select for SCK

Bit number	31	30	29	28	27	26	25	24	23	22	21	20	19	18	17	16	15	14	13	12	11	10	9	8	7	6	5	4	3	2	1	0															
ID																													B			A		A	A	A	A										
Reset 0xFFFFFFFF	1 1																																														
ID	R/W	Field	Value ID	Value	Description																																										
A	RW	PIN		[0..31]	Pin number																																										
B	RW	CONNECT			Connection																																										
			Disconnected	1	Disconnect																																										
			Connected	0	Connect																																										

6.13.6.24 PSEL.MOSI

Address offset: 0x50C

Pin select for MOSI signal

Bit number	31	30	29	28	27	26	25	24	23	22	21	20	19	18	17	16	15	14	13	12	11	10	9	8	7	6	5	4	3	2	1	0															
ID																													B			A		A	A	A	A										
Reset 0xFFFFFFFF	1 1																																														
ID	R/W	Field	Value ID	Value	Description																																										
A	RW	PIN		[0..31]	Pin number																																										
B	RW	CONNECT			Connection																																										
			Disconnected	1	Disconnect																																										
			Connected	0	Connect																																										

6.13.6.25 PSEL.MISO

Address offset: 0x510

Pin select for MISO signal

Bit number	31 30 29 28 27 26 25 24 23 22 21 20 19 18 17 16 15 14 13 12 11 10 9 8 7 6 5 4 3 2 1 0																														
ID	B																											A A A A A			
Reset 0xFFFFFFFF	1 1																														
ID	R/W	Field	Value ID	Value	Description																										
A	RW	PIN		[0..31]	Pin number																										
B	RW	CONNECT			Connection																										
			Disconnected	1	Disconnect																										
			Connected	0	Connect																										

6.13.6.26 FREQUENCY

Address offset: 0x524

SPI frequency. Accuracy depends on the HFCLK source selected.

Bit number	31 30 29 28 27 26 25 24 23 22 21 20 19 18 17 16 15 14 13 12 11 10 9 8 7 6 5 4 3 2 1 0																														
ID	A A																														
Reset 0x04000000	0 0 0 0 0 1 0																														
ID	R/W	Field	Value ID	Value	Description																										
A	RW	FREQUENCY			SPI master data rate																										
			K125	0x02000000	125 kbps																										
			K250	0x04000000	250 kbps																										
			K500	0x08000000	500 kbps																										
			M1	0x10000000	1 Mbps																										
			M2	0x20000000	2 Mbps																										
			M4	0x40000000	4 Mbps																										
			M8	0x80000000	8 Mbps																										

6.13.6.27 RXD

RXD EasyDMA channel

6.13.6.27.1 RXD.PTR

Address offset: 0x534

Data pointer

Bit number	31 30 29 28 27 26 25 24 23 22 21 20 19 18 17 16 15 14 13 12 11 10 9 8 7 6 5 4 3 2 1 0																														
ID	A A																														
Reset 0x00000000	0 0																														
ID	R/W	Field	Value ID	Value	Description																										
A	RW	PTR			Data pointer																										

Note: See the memory chapter for details about which memories are available for EasyDMA.

6.13.6.27.2 RXD.MAXCNT

Address offset: 0x538

Maximum number of bytes in receive buffer

Bit number	31	30	29	28	27	26	25	24	23	22	21	20	19	18	17	16	15	14	13	12	11	10	9	8	7	6	5	4	3	2	1	0
ID	A A A A A A A A A A A A A A A A A A																															
Reset 0x00000000	0 0																															
ID	R/W	Field	Value ID	Value	Description																											
A	RW	MAXCNT		[1..0x1FFF]	Maximum number of bytes in receive buffer																											

6.13.6.27.3 RXD.AMOUNT

Address offset: 0x53C

Number of bytes transferred in the last transaction

Bit number	31	30	29	28	27	26	25	24	23	22	21	20	19	18	17	16	15	14	13	12	11	10	9	8	7	6	5	4	3	2	1	0
ID	A A A A A A A A A A A A A A A A A A																															
Reset 0x00000000	0 0																															
ID	R/W	Field	Value ID	Value	Description																											
A	R	AMOUNT		[1..0x1FFF]	Number of bytes transferred in the last transaction																											

6.13.6.27.4 RXD.LIST

Address offset: 0x540

EasyDMA list type

Bit number	31	30	29	28	27	26	25	24	23	22	21	20	19	18	17	16	15	14	13	12	11	10	9	8	7	6	5	4	3	2	1	0
ID	A A																															
Reset 0x00000000	0 0																															
ID	R/W	Field	Value ID	Value	Description																											
A	RW	LIST			List type																											
			Disabled	0	Disable EasyDMA list																											
			ArrayList	1	Use array list																											

6.13.6.28 TXD

TXD EasyDMA channel

6.13.6.28.1 TXD.PTR

Address offset: 0x544

Data pointer

Bit number	31	30	29	28	27	26	25	24	23	22	21	20	19	18	17	16	15	14	13	12	11	10	9	8	7	6	5	4	3	2	1	0
ID	A A																															
Reset 0x00000000	0 0																															
ID	R/W	Field	Value ID	Value	Description																											
A	RW	PTR			Data pointer																											

Note: See the memory chapter for details about which memories are available for EasyDMA.

6.13.6.28.2 TXD.MAXCNT

Address offset: 0x548

Maximum number of bytes in transmit buffer

Bit number	31 30 29 28 27 26 25 24 23 22 21 20 19 18 17 16 15 14 13 12 11 10 9 8 7 6 5 4 3 2 1 0																														
ID	A A																														
Reset 0x00000000	0 0																														
ID	R/W	Field	Value ID	Value	Description																										
A	RW	MAXCNT		[1..0x1FFF]	Maximum number of bytes in transmit buffer																										

6.13.6.28.3 TXD.AMOUNT

Address offset: 0x54C

Number of bytes transferred in the last transaction

Bit number	31 30 29 28 27 26 25 24 23 22 21 20 19 18 17 16 15 14 13 12 11 10 9 8 7 6 5 4 3 2 1 0																														
ID	A A																														
Reset 0x00000000	0 0																														
ID	R/W	Field	Value ID	Value	Description																										
A	R	AMOUNT		[1..0x1FFF]	Number of bytes transferred in the last transaction																										

6.13.6.28.4 TXD.LIST

Address offset: 0x550

EasyDMA list type

Bit number	31 30 29 28 27 26 25 24 23 22 21 20 19 18 17 16 15 14 13 12 11 10 9 8 7 6 5 4 3 2 1 0																														
ID	A A																														
Reset 0x00000000	0 0																														
ID	R/W	Field	Value ID	Value	Description																										
A	RW	LIST			List type																										
			Disabled	0	Disable EasyDMA list																										
			ArrayList	1	Use array list																										

6.13.6.29 CONFIG

Address offset: 0x554

Configuration register

Bit number	31 30 29 28 27 26 25 24 23 22 21 20 19 18 17 16 15 14 13 12 11 10 9 8 7 6 5 4 3 2 1 0																																																								
ID																															C	B	A																								
Reset	0x00000000																														0	0	0	0	0	0	0	0	0	0	0	0	0	0	0	0	0	0	0	0	0	0	0	0	0	0	0
ID	R/W	Field	Value ID	Value	Description																																																				
A	RW	ORDER			Bit order																																																				
			MsbFirst	0	Most significant bit shifted out first																																																				
			LsbFirst	1	Least significant bit shifted out first																																																				
B	RW	CPHA			Serial clock (SCK) phase																																																				
			Leading	0	Sample on leading edge of clock, shift serial data on trailing edge																																																				
			Trailing	1	Sample on trailing edge of clock, shift serial data on leading edge																																																				
C	RW	CPOL			Serial clock (SCK) polarity																																																				
			ActiveHigh	0	Active high																																																				
			ActiveLow	1	Active low																																																				

6.13.6.30 ORC

Address offset: 0x5C0

Over-read character. Character clocked out in case an over-read of the TXD buffer.

Bit number	31 30 29 28 27 26 25 24 23 22 21 20 19 18 17 16 15 14 13 12 11 10 9 8 7 6 5 4 3 2 1 0																																																					
ID																															A	A	A	A	A	A	A																	
Reset	0x00000000																														0	0	0	0	0	0	0	0	0	0	0	0	0	0	0	0	0	0	0	0	0	0	0	0
ID	R/W	Field	Value ID	Value	Description																																																	
A	RW	ORC			Over-read character. Character clocked out in case an over-read of the TXD buffer.																																																	

6.13.7 Electrical specification

6.13.7.1 SPIM master interface electrical specifications

Symbol	Description	Min.	Typ.	Max.	Units
f _{SPIM}	Bit rates for SPIM ¹⁵			8	Mbps
t _{SPIM,START}	Time from START task to transmission started		1		µs

6.13.7.2 Serial Peripheral Interface Master (SPIM) timing specifications

Symbol	Description	Min.	Typ.	Max.	Units
t _{SPIM,CSCK}	SCK period		125		ns
t _{SPIM,RSCK,LD}	SCK rise time, standard drive ^a			t _{RF,25pF}	
t _{SPIM,RSCK,HD}	SCK rise time, high drive ^a			t _{HRF,25pF}	
t _{SPIM,FSCK,LD}	SCK fall time, standard drive ^a			t _{RF,25pF}	
t _{SPIM,FSCK,HD}	SCK fall time, high drive ^a			t _{HRF,25pF}	
t _{SPIM,WHSCCK}	SCK high time ^a	(0.5*t _{CSCK})			
		- t _{RSCK}			
t _{SPIM,WLSCCK}	SCK low time ^a	(0.5*t _{CSCK})			
		- t _{FSCK}			
t _{SPIM,SUMI}	MISO to CLK edge setup time	19			ns
t _{SPIM,HMI}	CLK edge to MISO hold time	18			ns

¹⁵ High bit rates may require GPIOs to be set as High Drive, see GPIO chapter for more details.

^a At 25pF load, including GPIO pin capacitance, see GPIO spec.

Symbol	Description	Min.	Typ.	Max.	Units
$t_{SPIM,VMO}$	CLK edge to MOSI valid			59	ns
$t_{SPIM,HMO}$	MOSI hold time after CLK edge	20			ns

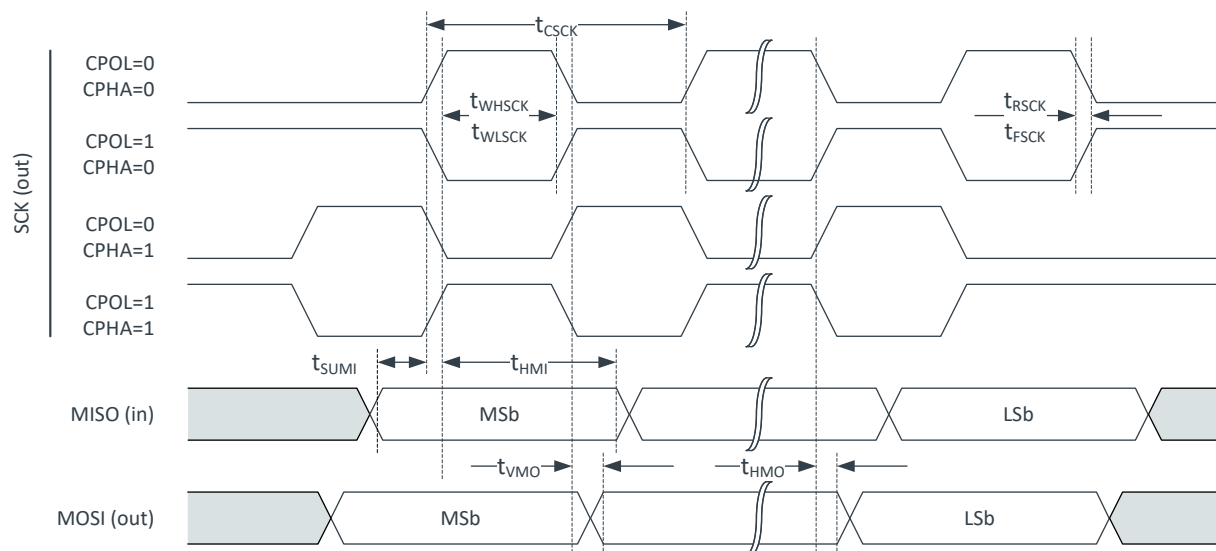

Figure 79: SPI timing diagram

6.14 SPIS — Serial peripheral interface slave with EasyDMA

SPI slave (SPIS) is implemented with EasyDMA support for ultra low power serial communication from an external SPI master. EasyDMA in conjunction with hardware-based semaphore mechanisms removes all real-time requirements associated with controlling the SPI slave from a low priority CPU execution context.

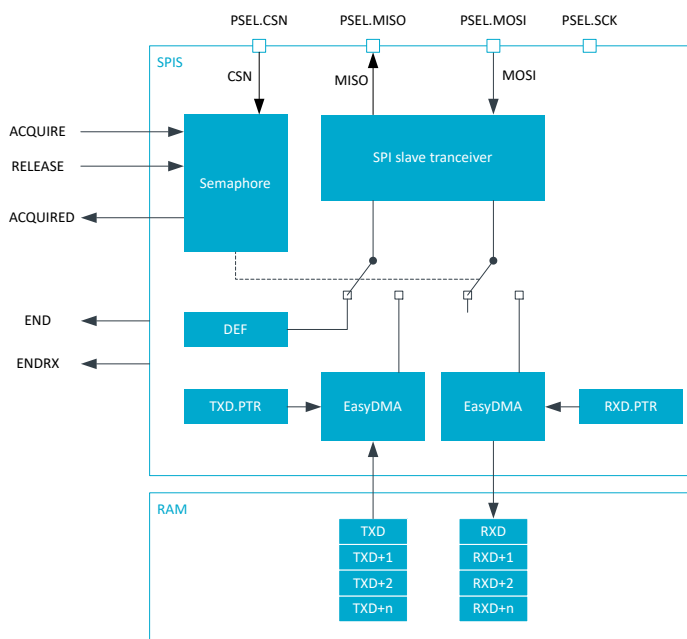

Figure 80: SPI slave

The SPIS supports SPI modes 0 through 3. The CONFIG register allows setting CPOL and CPHA appropriately.

Mode	Clock polarity	Clock phase
	CPOL	CPHA
SPI_MODE0	0 (Active High)	0 (Sample on Leading)
SPI_MODE1	0 (Active High)	1 (Sample on Trailing)
SPI_MODE2	1 (Active Low)	0 (Sample on Leading)
SPI_MODE3	1 (Active Low)	1 (Sample on Trailing)

Table 36: SPI modes

6.14.1 Shared resources

The SPI slave shares registers and other resources with other peripherals that have the same ID as the SPI slave. Therefore, you must disable all peripherals that have the same ID as the SPI slave before the SPI slave can be configured and used.

Disabling a peripheral that has the same ID as the SPI slave will not reset any of the registers that are shared with the SPI slave. It is important to configure all relevant SPI slave registers explicitly to secure that it operates correctly.

The Instantiation table in [Instantiation](#) on page 27 shows which peripherals have the same ID as the SPI slave.

6.14.2 EasyDMA

The SPIS implements EasyDMA for accessing RAM without CPU involvement.

The SPIS peripheral implements the following EasyDMA channels:

Channel	Type	Register Cluster
TXD	READER	TXD
RXD	WRITER	RXD

Table 37: SPIS EasyDMA Channels

For detailed information regarding the use of EasyDMA, see [EasyDMA](#) on page 48.

If RXD.MAXCNT is larger than TXD.MAXCNT, the remaining transmitted bytes will contain the value defined in the ORC register.

The END event indicates that EasyDMA has finished accessing the buffer in RAM.

6.14.3 SPI slave operation

SPI slave uses two memory pointers, RXD.PTR and TXD.PTR, that point to the RXD buffer (receive buffer) and TXD buffer (transmit buffer) respectively. Since these buffers are located in RAM, which can be accessed by both the SPI slave and the CPU, a hardware based semaphore mechanism is implemented to enable safe sharing.

Before the CPU can safely update the RXD.PTR and TXD.PTR pointers it must first acquire the SPI semaphore. The CPU can acquire the semaphore by triggering the ACQUIRE task and then receiving the ACQUIRED event. When the CPU has updated the RXD.PTR and TXD.PTR pointers the CPU must release the semaphore before the SPI slave will be able to acquire it.

The CPU releases the semaphore by triggering the RELEASE task, this is illustrated in [SPI transaction when shortcut between END and ACQUIRE is enabled](#) on page 310. Triggering the RELEASE task when the semaphore is not granted to the CPU will have no effect. See [Semaphore operation](#) on page 311 for more information

If the CPU is not able to reconfigure the TXD.PTR and RXD.PTR between granted transactions, the same TX data will be clocked out and the RX buffers will be overwritten. To prevent this from happening, the END_ACQUIRE shortcut can be used. With this shortcut enabled the semaphore will be handed over to the CPU automatically after the granted transaction has completed, giving the CPU the ability to update the TXPTR and RXPTR between every granted transaction.

The ENDRX event is generated when the RX buffer has been filled.

The RXD.MAXCNT register specifies the maximum number of bytes the SPI slave can receive in one granted transaction. If the SPI slave receives more than RXD.MAXCNT number of bytes, an OVERFLOW will be indicated in the STATUS register and the incoming bytes will be discarded.

The TXD.MAXCNT parameter specifies the maximum number of bytes the SPI slave can transmit in one granted transaction. If the SPI slave is forced to transmit more than TXD.MAXCNT number of bytes, an OVERREAD will be indicated in the STATUS register and the ORC character will be clocked out.

The RXD.AMOUNT and TXD.AMOUNT registers are updated when a granted transaction is completed. The TXD.AMOUNT register indicates how many bytes were read from the TX buffer in the last transaction, that is, ORC (over-read) characters are not included in this number. Similarly, the RXD.AMOUNT register indicates how many bytes were written into the RX buffer in the last transaction.

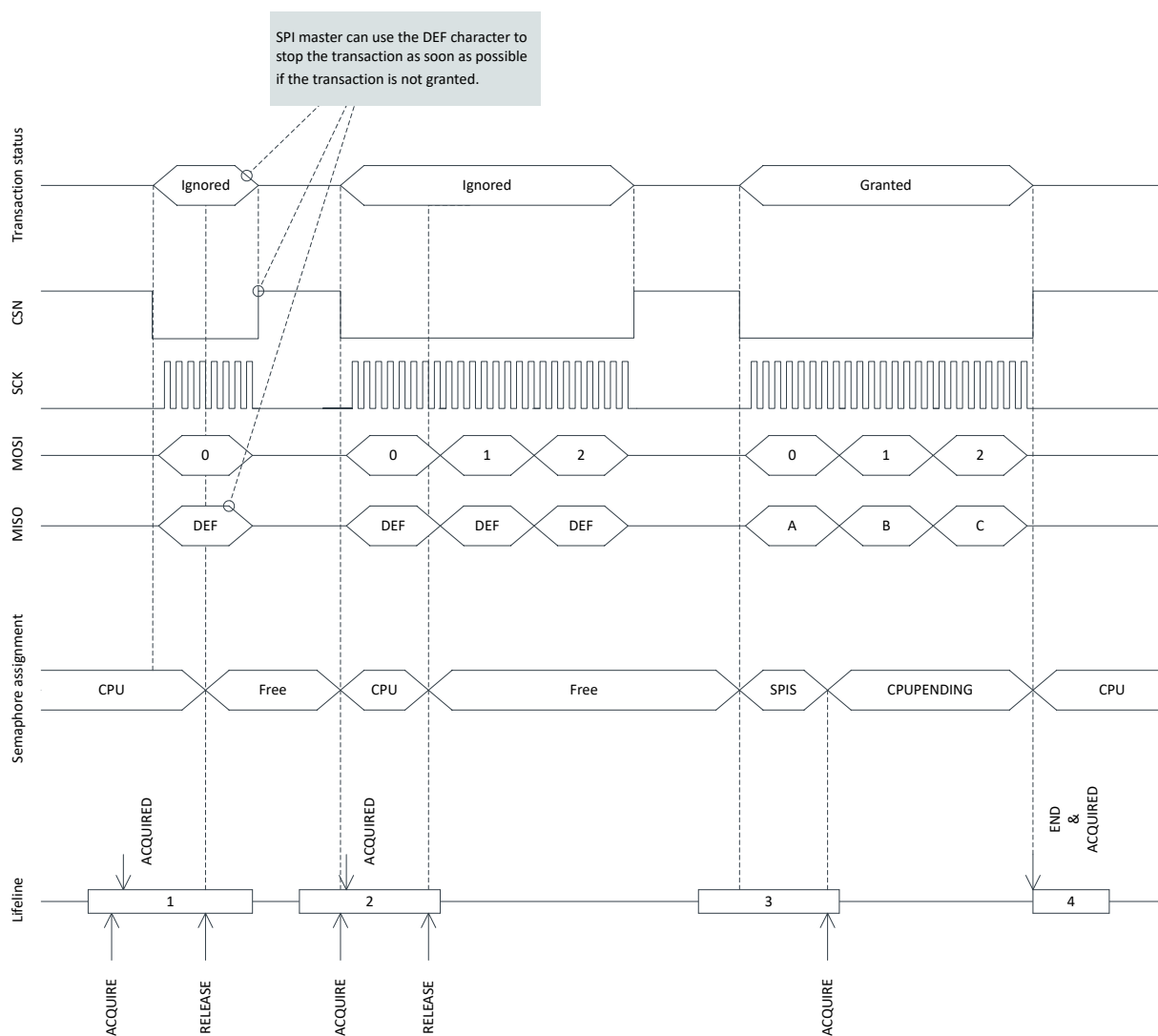

Figure 81: SPI transaction when shortcut between END and ACQUIRE is enabled

6.14.4 Semaphore operation

The semaphore is a mechanism implemented inside the SPI slave that prevents simultaneous access to the data buffers by the SPI slave and CPU.

The semaphore is by default assigned to the CPU after the SPI slave is enabled. No ACQUIRED event will be generated for this initial semaphore handover. An ACQUIRED event will be generated immediately if the ACQUIRE task is triggered while the semaphore is assigned to the CPU. The figure [SPI semaphore FSM](#) on page 311 illustrates the transitions between states in the semaphore based on the relevant tasks and events.

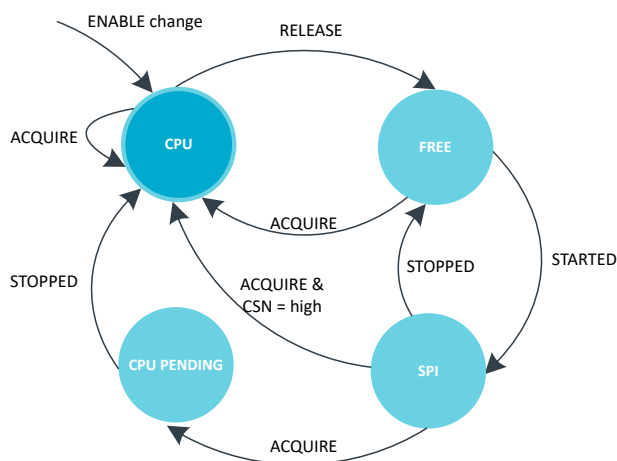

Figure 82: SPI semaphore FSM

Note: The semaphore mechanism does not, at any time, prevent the CPU from performing read or write access to the RXD.PTR register, the TXD.PTR registers, or the RAM that these pointers are pointing to. The semaphore is only telling when these can be updated by the CPU so that safe sharing is achieved.

The SPI slave will try to acquire the semaphore when STARTED event is detected, the event also indicates that CSN is currently low. If the SPI slave does not manage to acquire the semaphore at this point (i.e., it is under CPU's control), the transaction will be ignored. This means that all incoming data on MOSI will be discarded, and the DEF (default) character will be clocked out on the MISO line throughout the whole transaction. This will also be the case even if the semaphore is released by the CPU during the transaction. In case of a race condition where the CPU and the SPI slave try to acquire the semaphore at the same time, as illustrated in lifeline item 2 in figure [SPI transaction when shortcut between END and ACQUIRE is enabled](#) on page 310, the semaphore will be granted to the CPU.

If the SPI slave acquires the semaphore, the transaction will be granted. The incoming data on MOSI will be stored in the RXD buffer and the data in the TXD buffer will be clocked out on MISO.

When a granted transaction is completed and CSN goes high, the SPI slave will automatically release the semaphore and generate the END event.

As long as the semaphore is available, the SPI slave can be granted multiple transactions one after the other.

If the CPU tries to acquire the semaphore while it is assigned to the SPI slave, an immediate handover will not be granted. However, the semaphore will be handed over to the CPU as soon as the SPI slave has released the semaphore after the granted transaction is completed. If the END_ACQUIRE shortcut is enabled and the CPU has triggered the ACQUIRE task during a granted transaction, only one ACQUIRE request will be served following the END event.

6.14.5 Pin configuration

The CSN, SCK, MOSI, and MISO signals associated with the SPI slave are mapped to physical pins according to the configuration specified in the PSEL.CSN, PSEL.SCK, PSEL.MOSI, and PSEL.MISO registers respectively. If the CONNECT field of any of these registers is set to Disconnected, the associated SPI slave signal will not be connected to any physical pins.

The PSEL.CSN, PSEL.SCK, PSEL.MOSI, and PSEL.MISO registers and their configurations are only used as long as the SPI slave is enabled, and retained only as long as the device is in System ON mode, see [POWER — Power control](#) on page 69 chapter for more information about power modes. When the peripheral is disabled, the pins will behave as regular GPIOs, and use the configuration in their respective OUT bit field and PIN_CNF[n] register. PSEL.CSN, PSEL.SCK, PSEL.MOSI, and PSEL.MISO must only be configured when the SPI slave is disabled.

To secure correct behavior in the SPI slave, the pins used by the SPI slave must be configured in the GPIO peripheral as described in [GPIO configuration before enabling peripheral](#) on page 312 before enabling the SPI slave. This is to secure that the pins used by the SPI slave are driven correctly if the SPI slave itself is temporarily disabled, or if the device temporarily enters System OFF. This configuration must be retained in the GPIO for the selected I/Os as long as the SPI slave is to be recognized by an external SPI master.

The MISO line is set in high impedance as long as the SPI slave is not selected with CSN.

Only one peripheral can be assigned to drive a particular GPIO pin at a time. Failing to do so may result in unpredictable behavior.

SPI signal	SPI pin	Direction	Output value	Comment
CSN	As specified in PSEL.CSN	Input	Not applicable	
SCK	As specified in PSEL.SCK	Input	Not applicable	
MOSI	As specified in PSEL.MOSI	Input	Not applicable	
MISO	As specified in PSEL.MISO	Input	Not applicable	Emulates that the SPI slave is not selected.

Table 38: GPIO configuration before enabling peripheral

6.14.6 Registers

Instances

Instance	Base address	TrustZone			Split access	Description
		Map	Att	DMA		
SPIS0 : S	0x50008000	US	NS	SA	No	SPI slave 0
SPIS0 : NS	0x40008000					
SPIS1 : S	0x50009000	US	NS	SA	No	SPI slave 1
SPIS1 : NS	0x40009000					
SPIS2 : S	0x5000A000	US	NS	SA	No	SPI slave 2
SPIS2 : NS	0x4000A000					
SPIS3 : S	0x5000B000	US	NS	SA	No	SPI slave 3
SPIS3 : NS	0x4000B000					

Register overview

Register	Offset	TZ	Description
TASKS_ACQUIRE	0x024		Acquire SPI semaphore
TASKS_RELEASE	0x028		Release SPI semaphore, enabling the SPI slave to acquire it
SUBSCRIBE_ACQUIRE	0x0A4		Subscribe configuration for task ACQUIRE

Register	Offset	TZ	Description
SUBSCRIBE_RELEASE	0x0A8		Subscribe configuration for task RELEASE
EVENTS_END	0x104		Granted transaction completed
EVENTS_ENDRX	0x110		End of RXD buffer reached
EVENTS_ACQUIRED	0x128		Semaphore acquired
PUBLISH_END	0x184		Publish configuration for event END
PUBLISH_ENDRX	0x190		Publish configuration for event ENDRX
PUBLISH_ACQUIRED	0x1A8		Publish configuration for event ACQUIRED
SHORTS	0x200		Shortcuts between local events and tasks
INTENSET	0x304		Enable interrupt
INTENCLR	0x308		Disable interrupt
SEMSTAT	0x400		Semaphore status register
STATUS	0x440		Status from last transaction
ENABLE	0x500		Enable SPI slave
PSEL.SCK	0x508		Pin select for SCK
PSEL.MISO	0x50C		Pin select for MISO signal
PSEL.MOSI	0x510		Pin select for MOSI signal
PSEL.CSN	0x514		Pin select for CSN signal
RXD.PTR	0x534		RXD data pointer
RXD.MAXCNT	0x538		Maximum number of bytes in receive buffer
RXD.AMOUNT	0x53C		Number of bytes received in last granted transaction
RXD.LIST	0x540		EasyDMA list type
TXD.PTR	0x544		TXD data pointer
TXD.MAXCNT	0x548		Maximum number of bytes in transmit buffer
TXD.AMOUNT	0x54C		Number of bytes transmitted in last granted transaction
TXD.LIST	0x550		EasyDMA list type
CONFIG	0x554		Configuration register
DEF	0x55C		Default character. Character clocked out in case of an ignored transaction.
ORC	0x5C0		Over-read character

6.14.6.1 TASKS_ACQUIRE

Address offset: 0x024

Acquire SPI semaphore

Bit number	31 30 29 28 27 26 25 24 23 22 21 20 19 18 17 16 15 14 13 12 11 10 9 8 7 6 5 4 3 2 1 0																														
ID	A																														
Reset 0x00000000	0 0																														
ID	R/W	Field	Value ID	Value	Description																										
A	W	TASKS_ACQUIRE			Acquire SPI semaphore																										
			Trigger	1	Trigger task																										

6.14.6.2 TASKS_RELEASE

Address offset: 0x028

Release SPI semaphore, enabling the SPI slave to acquire it

Bit number	31 30 29 28 27 26 25 24 23 22 21 20 19 18 17 16 15 14 13 12 11 10 9 8 7 6 5 4 3 2 1 0																														
ID	A																														
Reset 0x00000000	0 0																														
ID	R/W	Field	Value ID	Value	Description																										
A	W	TASKS_RELEASE			Release SPI semaphore, enabling the SPI slave to acquire it																										
			Trigger	1	Trigger task																										

6.14.6.3 SUBSCRIBE_ACQUIRE

Address offset: 0x0A4

Subscribe configuration for task **ACQUIRE**

Bit number	31 30 29 28 27 26 25 24 23 22 21 20 19 18 17 16 15 14 13 12 11 10 9 8 7 6 5 4 3 2 1 0																														
ID	B																												A A A A A A A A		
Reset 0x00000000	0 0																														
ID	R/W	Field	Value ID	Value	Description																										
A	RW	CHIDX		[0..255]	DPPI channel that task ACQUIRE will subscribe to																										
B	RW	EN	Disabled	0	Disable subscription																										
			Enabled	1	Enable subscription																										

6.14.6.4 SUBSCRIBE_RELEASE

Address offset: 0x0A8

Subscribe configuration for task **RELEASE**

Bit number	31 30 29 28 27 26 25 24 23 22 21 20 19 18 17 16 15 14 13 12 11 10 9 8 7 6 5 4 3 2 1 0																														
ID	B																												A A A A A A A A		
Reset 0x00000000	0 0																														
ID	R/W	Field	Value ID	Value	Description																										
A	RW	CHIDX		[0..255]	DPPI channel that task RELEASE will subscribe to																										
B	RW	EN	Disabled	0	Disable subscription																										
			Enabled	1	Enable subscription																										

6.14.6.5 EVENTS_END

Address offset: 0x104

Granted transaction completed

Bit number	31 30 29 28 27 26 25 24 23 22 21 20 19 18 17 16 15 14 13 12 11 10 9 8 7 6 5 4 3 2 1 0																														
ID																															A
Reset 0x00000000	0 0																														
ID	R/W	Field	Value ID	Value	Description																										
A	RW	EVENTS_END			Granted transaction completed																										
			NotGenerated	0	Event not generated																										
			Generated	1	Event generated																										

6.14.6.6 EVENTS_ENDRX

Address offset: 0x110

End of RXD buffer reached

Bit number	31	30	29	28	27	26	25	24	23	22	21	20	19	18	17	16	15	14	13	12	11	10	9	8	7	6	5	4	3	2	1	0
ID	A																															
Reset 0x00000000	0 0																															
ID	R/W	Field	Value ID	Value	Description																											
A	RW	EVENTS_ENDRX			End of RXD buffer reached																											
			NotGenerated	0	Event not generated																											
			Generated	1	Event generated																											

6.14.6.7 EVENTS_ACQUIRED

Address offset: 0x128

Semaphore acquired

Bit number	31	30	29	28	27	26	25	24	23	22	21	20	19	18	17	16	15	14	13	12	11	10	9	8	7	6	5	4	3	2	1	0
ID	A																															
Reset 0x00000000	0 0																															
ID	R/W	Field	Value ID	Value	Description																											
A	RW	EVENTS_ACQUIRED			Semaphore acquired																											
			NotGenerated	0	Event not generated																											
			Generated	1	Event generated																											

6.14.6.8 PUBLISH_END

Address offset: 0x184

Publish configuration for event END

Bit number	31	30	29	28	27	26	25	24	23	22	21	20	19	18	17	16	15	14	13	12	11	10	9	8	7	6	5	4	3	2	1	0
ID	B															A A A A A A A A																
Reset 0x00000000	0 0																															
ID	R/W	Field	Value ID	Value	Description																											
A	RW	CHIDX		[0..255]	DPPI channel that event END will publish to																											
B	RW	EN																														
			Disabled	0	Disable publishing																											
			Enabled	1	Enable publishing																											

6.14.6.9 PUBLISH_ENDRX

Address offset: 0x190

Publish configuration for event ENDRX

Bit number	31	30	29	28	27	26	25	24	23	22	21	20	19	18	17	16	15	14	13	12	11	10	9	8	7	6	5	4	3	2	1	0
ID	B															A A A A A A A A																
Reset 0x00000000	0 0																															
ID	R/W	Field	Value ID	Value	Description																											
A	RW	CHIDX		[0..255]	DPPI channel that event ENDRX will publish to																											
B	RW	EN																														
			Disabled	0	Disable publishing																											
			Enabled	1	Enable publishing																											

6.14.6.10 PUBLISH_ACQUIRED

Address offset: 0x1A8

Publish configuration for event **ACQUIRED**

Bit number	31 30 29 28 27 26 25 24 23 22 21 20 19 18 17 16 15 14 13 12 11 10 9 8 7 6 5 4 3 2 1 0																														
ID	B																								A						
Reset 0x00000000	0 0																														
ID	R/W	Field	Value ID	Value	Description																										
A	RW	CHIDX		[0..255]	DPPI channel that event ACQUIRED will publish to																										
B	RW	EN	Disabled	0	Disable publishing																										
			Enabled	1	Enable publishing																										

6.14.6.11 SHORTS

Address offset: 0x200

Shortcuts between local events and tasks

Bit number	31 30 29 28 27 26 25 24 23 22 21 20 19 18 17 16 15 14 13 12 11 10 9 8 7 6 5 4 3 2 1 0																														
ID																									A						
Reset 0x00000000	0 0																														
ID	R/W	Field	Value ID	Value	Description																										
A	RW	END_ACQUIRE	Disabled	0	Shortcut between event END and task ACQUIRE																										
			Enabled	1	Enable shortcut																										

6.14.6.12 INTENSET

Address offset: 0x304

Enable interrupt

Bit number	31 30 29 28 27 26 25 24 23 22 21 20 19 18 17 16 15 14 13 12 11 10 9 8 7 6 5 4 3 2 1 0																														
ID											C							B							A						
Reset 0x00000000	0 0																														
ID	R/W	Field	Value ID	Value	Description																										
A	RW	END	Set	1	Write '1' to enable interrupt for event END																										
			Disabled	0	Enable																										
			Enabled	1	Read: Disabled																										
B	RW	ENDRX	Set	1	Write '1' to enable interrupt for event ENDRX																										
			Disabled	0	Enable																										
			Enabled	1	Read: Disabled																										
C	RW	ACQUIRED	Set	1	Write '1' to enable interrupt for event ACQUIRED																										
			Disabled	0	Enable																										
			Enabled	1	Read: Disabled																										

6.14.6.13 INTENCLR

Address offset: 0x308

Disable interrupt

Bit number	31 30 29 28 27 26 25 24 23 22 21 20 19 18 17 16 15 14 13 12 11 10 9 8 7 6 5 4 3 2 1 0																																	
ID																														C		B		A
Reset 0x00000000	0 0																																	
ID	R/W	Field	Value ID	Value	Description																													
A	RW	END			Write '1' to disable interrupt for event END																													
			Clear	1	Disable																													
			Disabled	0	Read: Disabled																													
			Enabled	1	Read: Enabled																													
B	RW	ENDRX			Write '1' to disable interrupt for event ENDRX																													
			Clear	1	Disable																													
			Disabled	0	Read: Disabled																													
			Enabled	1	Read: Enabled																													
C	RW	ACQUIRED			Write '1' to disable interrupt for event ACQUIRED																													
			Clear	1	Disable																													
			Disabled	0	Read: Disabled																													
			Enabled	1	Read: Enabled																													

6.14.6.14 SEMSTAT

Address offset: 0x400

Semaphore status register

Bit number	31 30 29 28 27 26 25 24 23 22 21 20 19 18 17 16 15 14 13 12 11 10 9 8 7 6 5 4 3 2 1 0																															
ID																														A		A
Reset 0x00000001	0 1																															
ID	R/W	Field	Value ID	Value	Description																											
A	R	SEMSTAT			Semaphore status																											
			Free	0	Semaphore is free																											
			CPU	1	Semaphore is assigned to CPU																											
			SPIS	2	Semaphore is assigned to SPI slave																											
			CPUPending	3	Semaphore is assigned to SPI but a handover to the CPU is pending																											

6.14.6.15 STATUS

Address offset: 0x440

Status from last transaction

Note: Individual bits are cleared by writing a '1' to the bits that shall be cleared

Bit number	31 30 29 28 27 26 25 24 23 22 21 20 19 18 17 16 15 14 13 12 11 10 9 8 7 6 5 4 3 2 1 0																															
ID																														B		A
Reset 0x00000000	0 0																															
ID	R/W	Field	Value ID	Value	Description																											
A	RW	OVERREAD			TX buffer over-read detected, and prevented																											
			NotPresent	0	Read: error not present																											
			Present	1	Read: error present																											
			Clear	1	Write: clear error on writing '1'																											
B	RW	OVERFLOW			RX buffer overflow detected, and prevented																											
			NotPresent	0	Read: error not present																											
			Present	1	Read: error present																											
			Clear	1	Write: clear error on writing '1'																											

6.14.6.16 ENABLE

Address offset: 0x500

Enable SPI slave

Bit number	31 30 29 28 27 26 25 24 23 22 21 20 19 18 17 16 15 14 13 12 11 10 9 8 7 6 5 4 3 2 1 0																																
ID																													A	A	A	A	
Reset 0x00000000	0 0																																
ID	R/W	Field	Value ID	Value	Description																												
A	RW	ENABLE			Enable or disable SPI slave																												
			Disabled	0	Disable SPI slave																												
			Enabled	2	Enable SPI slave																												

6.14.6.17 PSEL.SCK

Address offset: 0x508

Pin select for SCK

Bit number	31 30 29 28 27 26 25 24 23 22 21 20 19 18 17 16 15 14 13 12 11 10 9 8 7 6 5 4 3 2 1 0																																
ID	B																												A	A	A	A	A
Reset 0xFFFFFFFF	1 1																																
ID	R/W	Field	Value ID	Value	Description																												
A	RW	PIN		[0..31]	Pin number																												
B	RW	CONNECT			Connection																												
			Disconnected	1	Disconnect																												
			Connected	0	Connect																												

6.14.6.18 PSEL.MISO

Address offset: 0x50C

Pin select for MISO signal

Bit number	31 30 29 28 27 26 25 24 23 22 21 20 19 18 17 16 15 14 13 12 11 10 9 8 7 6 5 4 3 2 1 0																																
ID	B																												A	A	A	A	A
Reset 0xFFFFFFFF	1 1																																
ID	R/W	Field	Value ID	Value	Description																												
A	RW	PIN		[0..31]	Pin number																												
B	RW	CONNECT			Connection																												
			Disconnected	1	Disconnect																												
			Connected	0	Connect																												

6.14.6.19 PSEL.MOSI

Address offset: 0x510

Pin select for MOSI signal

Bit number	31	30	29	28	27	26	25	24	23	22	21	20	19	18	17	16	15	14	13	12	11	10	9	8	7	6	5	4	3	2	1	0
ID	B																A A A A A															
Reset 0xFFFFFFFF	1 1																															
ID	R/W	Field	Value ID	Value	Description																											
A	RW	PIN		[0..31]	Pin number																											
B	RW	CONNECT			Connection																											
			Disconnected	1	Disconnect																											
			Connected	0	Connect																											

6.14.6.20 PSEL.CSN

Address offset: 0x514

Pin select for CSN signal

Bit number	31	30	29	28	27	26	25	24	23	22	21	20	19	18	17	16	15	14	13	12	11	10	9	8	7	6	5	4	3	2	1	0
ID	B																A A A A A															
Reset 0xFFFFFFFF	1 1																															
ID	R/W	Field	Value ID	Value	Description																											
A	RW	PIN		[0..31]	Pin number																											
B	RW	CONNECT			Connection																											
			Disconnected	1	Disconnect																											
			Connected	0	Connect																											

6.14.6.21 RXD.PTR

Address offset: 0x534

RXD data pointer

Bit number	31	30	29	28	27	26	25	24	23	22	21	20	19	18	17	16	15	14	13	12	11	10	9	8	7	6	5	4	3	2	1	0
ID	A	A	A	A	A	A	A	A	A	A	A	A	A	A	A	A	A	A	A	A	A	A	A	A	A	A	A	A	A	A	A	
Reset 0x00000000	0 0																															
ID	R/W	Field	Value ID	Value	Description																											
A	RW	PTR			RXD data pointer																											

See the Memory chapter for details about which memories are available for EasyDMA.

6.14.6.22 RXD.MAXCNT

Address offset: 0x538

Maximum number of bytes in receive buffer

Bit number	31	30	29	28	27	26	25	24	23	22	21	20	19	18	17	16	15	14	13	12	11	10	9	8	7	6	5	4	3	2	1	0
ID																	A A A A A A A A A A A A A A A A															
Reset 0x00000000	0 0																															
ID	R/W	Field	Value ID	Value	Description																											
A	RW	MAXCNT		[1..0x1FFF]	Maximum number of bytes in receive buffer																											

6.14.6.23 RXD.AMOUNT

Address offset: 0x53C

Number of bytes received in last granted transaction

Bit number	31	30	29	28	27	26	25	24	23	22	21	20	19	18	17	16	15	14	13	12	11	10	9	8	7	6	5	4	3	2	1	0
ID	A A																															
Reset 0x00000000	0 0																															
ID	R/W	Field	Value ID	Value	Description																											
A	R	AMOUNT		[1..0x1FFF]	Number of bytes received in the last granted transaction																											

6.14.6.24 RXD.LIST

Address offset: 0x540

EasyDMA list type

Bit number	31	30	29	28	27	26	25	24	23	22	21	20	19	18	17	16	15	14	13	12	11	10	9	8	7	6	5	4	3	2	1	0
ID	A A																															
Reset 0x00000000	0 0																															
ID	R/W	Field	Value ID	Value	Description																											
A	RW	LIST			List type																											
			Disabled	0	Disable EasyDMA list																											
			ArrayList	1	Use array list																											

6.14.6.25 TXD.PTR

Address offset: 0x544

TXD data pointer

Bit number	31	30	29	28	27	26	25	24	23	22	21	20	19	18	17	16	15	14	13	12	11	10	9	8	7	6	5	4	3	2	1	0
ID	A A																															
Reset 0x00000000	0 0																															
ID	R/W	Field	Value ID	Value	Description																											
A	RW	PTR			TXD data pointer																											
					See the Memory chapter for details about which memories are available for EasyDMA.																											

6.14.6.26 TXD.MAXCNT

Address offset: 0x548

Maximum number of bytes in transmit buffer

Bit number	31	30	29	28	27	26	25	24	23	22	21	20	19	18	17	16	15	14	13	12	11	10	9	8	7	6	5	4	3	2	1	0
ID	A A																															
Reset 0x00000000	0 0																															
ID	R/W	Field	Value ID	Value	Description																											
A	RW	MAXCNT		[1..0x1FFF]	Maximum number of bytes in transmit buffer																											

6.14.6.27 TXD.AMOUNT

Address offset: 0x54C

Number of bytes transmitted in last granted transaction

Bit number	31	30	29	28	27	26	25	24	23	22	21	20	19	18	17	16	15	14	13	12	11	10	9	8	7	6	5	4	3	2	1	0																							
ID																											A	A	A	A	A	A	A	A	A	A	A	A	A	A	A	A	A	A	A	A	A	A	A	A	A	A	A	A	A
Reset 0x00000000	0																																																						
ID	R/W	Field	Value ID	Value	Description																																																		
A	R	AMOUNT		[1..0x1FFF]	Number of bytes transmitted in last granted transaction																																																		

6.14.6.28 TXD.LIST

Address offset: 0x550

EasyDMA list type

Bit number	31	30	29	28	27	26	25	24	23	22	21	20	19	18	17	16	15	14	13	12	11	10	9	8	7	6	5	4	3	2	1	0
ID																											A	A				
Reset 0x00000000	0																															
ID	R/W	Field	Value ID	Value	Description																											
A	RW	LIST			List type																											
			Disabled	0	Disable EasyDMA list																											
			ArrayList	1	Use array list																											

6.14.6.29 CONFIG

Address offset: 0x554

Configuration register

Bit number	31	30	29	28	27	26	25	24	23	22	21	20	19	18	17	16	15	14	13	12	11	10	9	8	7	6	5	4	3	2	1	0
ID																											C	B	A			
Reset 0x00000000	0																															
ID	R/W	Field	Value ID	Value	Description																											
A	RW	ORDER			Bit order																											
			MsbFirst	0	Most significant bit shifted out first																											
			LsbFirst	1	Least significant bit shifted out first																											
B	RW	CPHA			Serial clock (SCK) phase																											
			Leading	0	Sample on leading edge of clock, shift serial data on trailing edge																											
			Trailing	1	Sample on trailing edge of clock, shift serial data on leading edge																											
C	RW	CPOL			Serial clock (SCK) polarity																											
			ActiveHigh	0	Active high																											
			ActiveLow	1	Active low																											

6.14.6.30 DEF

Address offset: 0x55C

Default character. Character clocked out in case of an ignored transaction.

Bit number	31	30	29	28	27	26	25	24	23	22	21	20	19	18	17	16	15	14	13	12	11	10	9	8	7	6	5	4	3	2	1	0																							
ID																											A	A	A	A	A	A	A	A	A	A	A	A	A	A	A	A	A	A	A	A	A	A	A	A	A	A	A	A	A
Reset 0x00000000	0																																																						
ID	R/W	Field	Value ID	Value	Description																																																		
A	RW	DEF			Default character. Character clocked out in case of an ignored transaction.																																																		

6.14.6.31 ORC

Address offset: 0x5C0

Over-read character

Bit number	31	30	29	28	27	26	25	24	23	22	21	20	19	18	17	16	15	14	13	12	11	10	9	8	7	6	5	4	3	2	1	0
ID	A A A A A A A A																															
Reset 0x00000000	0 0																															
ID	R/W	Field	Value ID	Value	Description																											
A	RW	ORC			Over-read character. Character clocked out after an over-read of the transmit buffer.																											

6.14.7 Electrical specification

6.14.7.1 SPIS slave interface electrical specifications

Symbol	Description	Min.	Typ.	Max.	Units
f _{SPIS}	Bit rates for SPIS ¹⁶			8 ¹⁷	Mbps
t _{SPIS,START}	Time from RELEASE task to receive/transmit (CSN active)		0.125		µs

6.14.7.2 Serial Peripheral Interface Slave (SPIS) timing specifications

Symbol	Description	Min.	Typ.	Max.	Units
t _{SPIS,CSCKIN}	SCK input period	125			ns
t _{SPIS,RFSCCKIN}	SCK input rise/fall time			30	ns
t _{SPIS,WHSCCKIN}	SCK input high time	30			ns
t _{SPIS,WLSCCKIN}	SCK input low time	30			ns
t _{SPIS,SUCSN}	CSN to CLK setup time	1000			ns
t _{SPIS,HCSN}	CLK to CSN hold time	2000			ns
t _{SPIS,ASA}	CSN to MISO driven	0			ns
t _{SPIS,ASO}	CSN to MISO valid ^a			1000	ns
t _{SPIS,DISSO}	CSN to MISO disabled ^a			68	ns
t _{SPIS,CWH}	CSN inactive time	300			ns
t _{SPIS,VSO}	CLK edge to MISO valid			59	ns
t _{SPIS,HSO}	MISO hold time after CLK edge	20 ¹⁸			ns
t _{SPIS,SUSI}	MOSI to CLK edge setup time	19			ns
t _{SPIS,HSI}	CLK edge to MOSI hold time	18			ns

¹⁶ High bit rates may require GPIOs to be set as High Drive, see GPIO chapter for more details.

¹⁷ The actual maximum data rate depends on the master's CLK to MISO and MOSI setup and hold timings.

^a At 25pF load, including GPIO capacitance, see GPIO spec.

¹⁸ This is to ensure compatibility to SPI masters sampling MISO on the same edge as MOSI is output

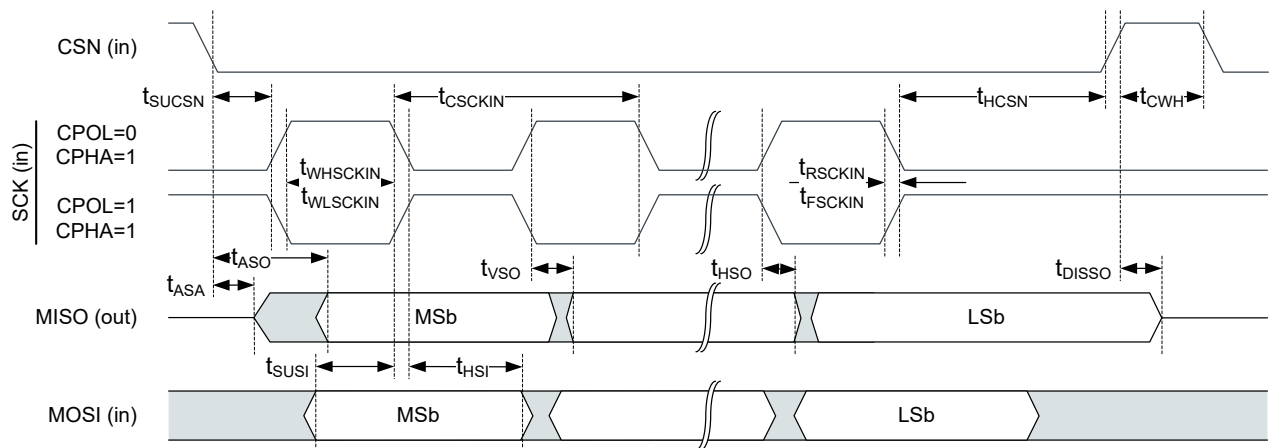
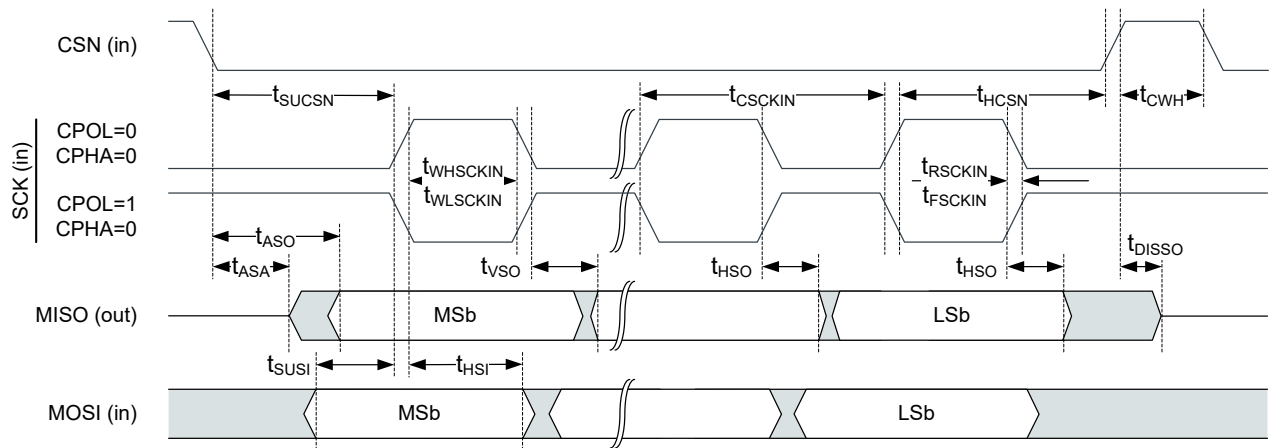

Figure 83: SPI timing diagram

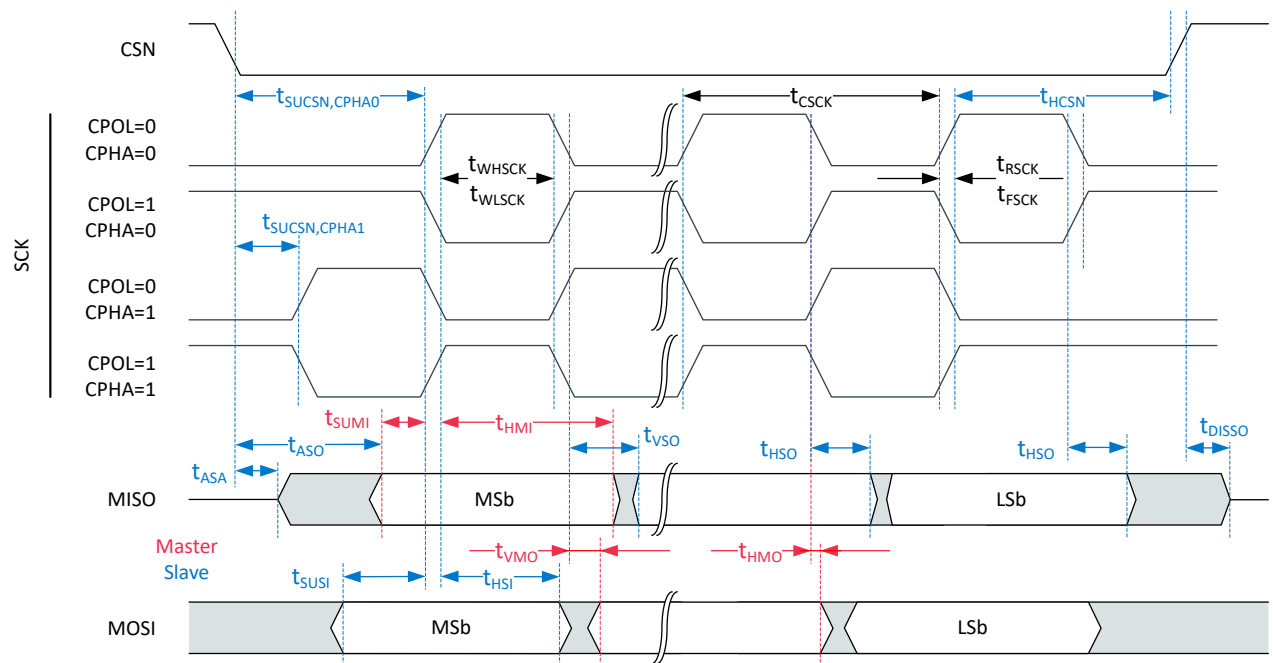

Figure 84: Common SPIM and SPI timing diagram

6.15 SPU — System protection unit

SPU is the central point in the system to control access to memories, peripherals and other resources.

Listed here are the main features of the SPU:

- ARM TrustZone support, allowing definition of secure, non-secure and non-secure callable memory regions
- Extended ARMTrustZone, protecting memory regions and peripherals from non-CPU devices like EasyDMA transfer
- Pin access protection, preventing non-secure code and peripherals from accessing secure pin resources
- DPPI access protection, realized by preventing non-secure code and peripherals to publish from or subscribe to secured DPPI channels
- External domain access protection, controlling access rights from other MCUs

6.15.1 General concepts

SPU provides a register interface to control the various internal logic blocks that monitor access to memory-mapped slave devices (RAM, flash, peripherals, etc) and other resources (device pins, DPPI channels, etc).

For memory-mapped devices like RAM, flash and peripherals, the internal logic checks the address and attributes (e.g. read, write, execute, secure) of the incoming transfer to block it if necessary. Whether a secure resource can be accessed by a given master is defined:

For a CPU-type master

By the security state of the CPU and the security state reported by the SPU, for the address in the bus transfer

For a non-CPU master

By the security attribute of the master that initiates the transfer, defined by a SPU register

The [Simplified view of the protection of RAM, flash and peripherals using SPU](#) on page 324 shows a simplified view of the SPU registers controlling several internal modules.

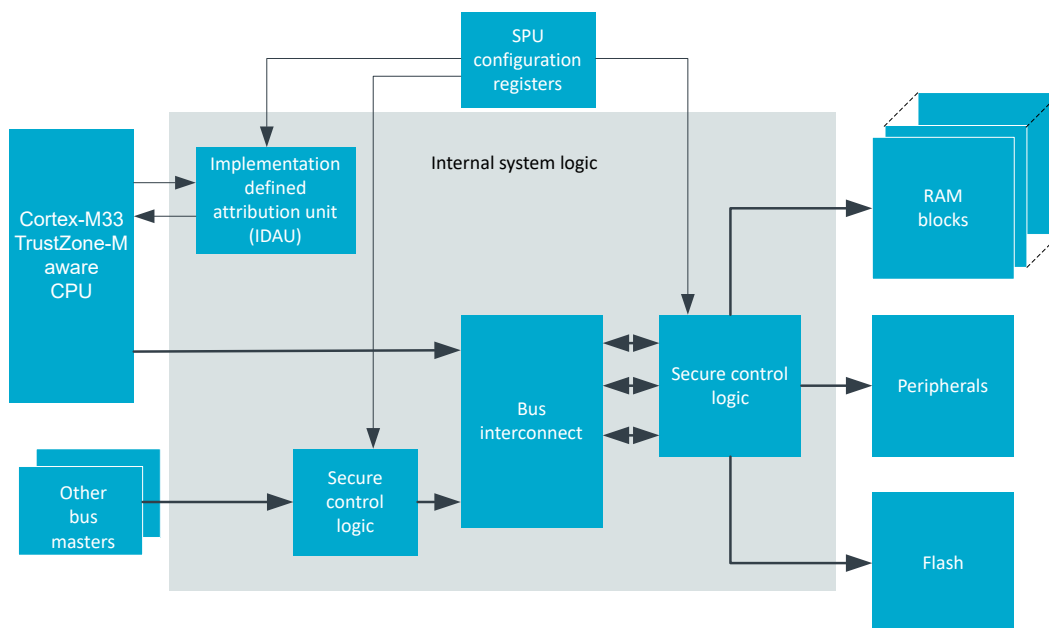

Figure 85: Simplified view of the protection of RAM, flash and peripherals using SPU

The protection logic implements a read-as-zero/write-ignore (RAZ/WI) policy:

- A blocked read operation will always return a zero value on the bus, preventing information leak
- A write operation to a forbidden region or peripheral will be ignored

An error is reported through dedicated error signals. For security state violations from an M33 master this will be a SecureFault exception, for other violations this will be an SPU event. The SPU event can be configured to generate an interrupt towards the CPU.

Other resources like pins and DPPI channels are protected by comparing the security attributes of the protected resource with the security attribute of the peripheral that wants to access it. The SPU is the only place where those security attributes can be configured.

6.15.1.1 Special considerations for ARM TrustZone for Cortex-M enabled system

For a ARM TrustZone for Cortex-M enabled CPU, the SPU also controls custom logic.

Custom logic is shown as the implementation defined attribution unit (IDAU) in figure [Simplified view of the protection of RAM, flash and peripherals using SPU](#) on page 324. Full support is provided for:

- ARM TrustZone for Cortex-M related instructions, like test target (TT) for reporting the security attributes of a region
- Non-secure callable (NSC) regions, to implement secure entry points from non-secure code

The SPU provides the necessary registers to configure the security attributes for memory regions and peripherals. However, as a requirement to use the SPU, the secure attribution unit (SAU) needs to be disabled and all memory set as non-secure in the ARM core. This will allow the SPU to control the IDAU and set the security attribution of all addresses as originally intended.

6.15.2 Flash access control

The flash memory space is divided in regions, each of them with configurable permissions settings.

The flash memory space is divided into 32 regions of 32 KiB .

For each region, four different types of permissions can be configured:

Read

Allows data read access to the region. Note that code fetch from this region is not controlled by the read permission but by the execute permission described below.

Write

Allows write or page erase access to the region

Execute

Allows code fetch from this region, even if data read is disabled

Secure

Allows only bus accesses with the security attribute set to access the region

Permissions can be set independently. For example, it is possible to configure a flash region to be accessible only through secure transfer, being read-only (no write allowed) and non-executable (no code fetch allowed). For each region, permissions can be set and then locked by using the [FLASHREGION\[n\].PERM.LOCK](#) bit, to prevent subsequent modifications.

Note that the debugger is able to step through execute-protected memory regions.

The following figure shows the flash memory space and the divided regions:

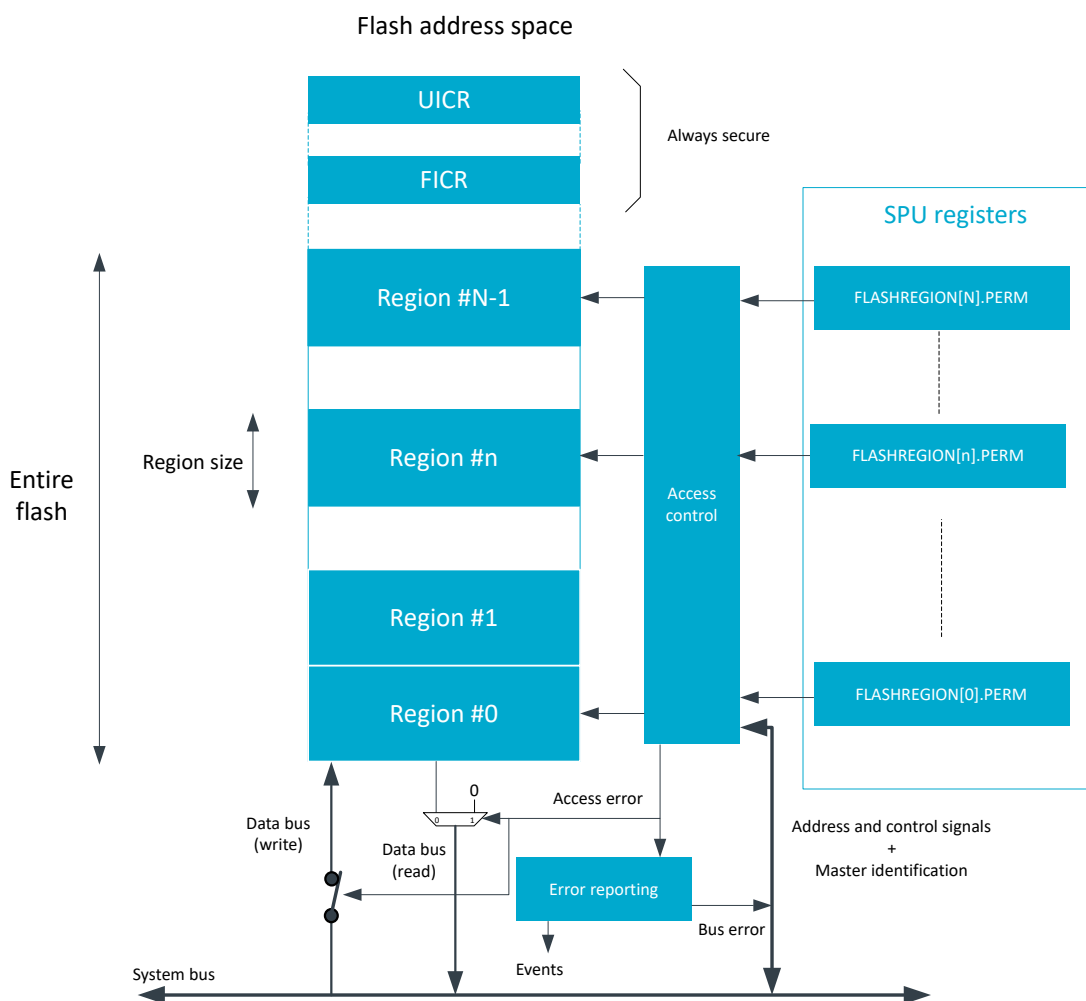

Figure 86: Definition of the $N=32$ regions, each of 32 KiB, in the flash memory space

6.15.2.1 Non-secure callable (NSC) region definition in flash

The SPU provides support for the definition of non-secure callable (NSC) sub-regions to allow non-secure to secure function calls.

A non-secure callable sub-region can only exist within an existing secure region and its definition is done using two registers:

- `FLASHNSC[n].REGION`, used to select the secure region that will contain the NSC sub-region
- `FLASHNSC[n].SIZE`, used to define the size of the NSC sub-region within the secure region

The NSC sub-region will be defined from the highest address in that region, going downwards. Figure below illustrates the NSC sub-regions and the registers used for their definition:

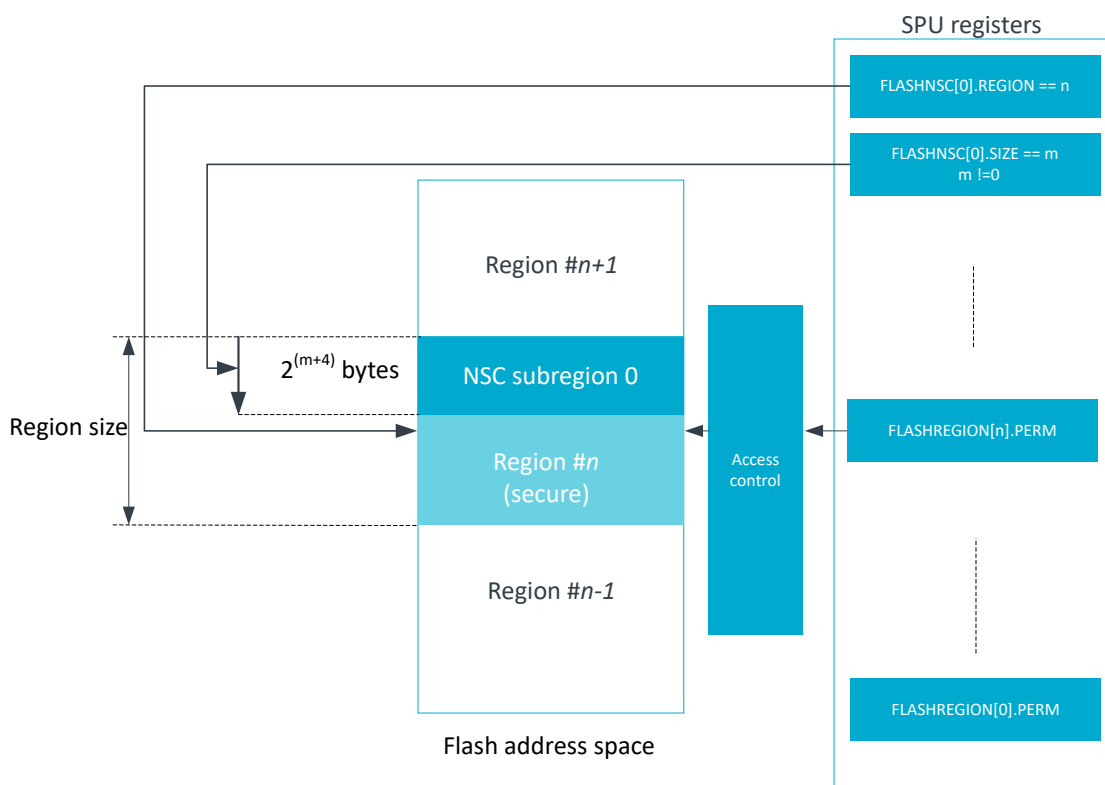

Figure 87: Non-secure callable region definition in the flash memory space

The NSC sub-region will only be defined if:

- FLASHNSC[i].SIZE value is non zero
- FLASHNSC[i].REGION defines a secure region

If FLASHNSC[i].REGION and FLASHNSC[j].REGION have the same value, there is only one sub-region defined as NSC, with the size given by the maximum of FLASHNSC[i].SIZE and FLASHNSC[j].SIZE.

If FLASHNSC[i].REGION defines a non-secure region, then there is no non-secure callable region defined and the selected region stays non-secure.

6.15.2.2 Flash access error reporting

The SPU and the logic controlled by it will respond with a certain behavior once an access violation is detected.

The following will happen once the logic controlled by the SPU detects an access violation on one of the flash ports:

- The faulty transfer will be blocked
- In case of a read transfer, the bus will be driven to zero
- Feedback will be sent to the master through specific bus error signals, if this is supported by the master. Moreover, the SPU will receive an event that can optionally trigger an interrupt towards the CPU.
- SecureFault exception will be triggered if security violation is detected for access from Cortex-M33
- BusFault exception will be triggered when read/write/execute protection violation is detected for Cortex-M33
- FLASHACCERR event will be triggered if any access violations are detected for all master types except for Cortex-M33 security violation

The following table summarizes the SPU behavior based on the type of initiator and access violation:

Master type	Security violation	Read/Write/Execute protection violation
Cortex-M33	SecureFault exception	BusFault exception, FLASHACCERR event
EasyDMA	RAZ/WI, FLASHACCERR event	RAZ/WI, FLASHACCERR event
Other masters	RAZ/WI, FLASHACCERR event	RAZ/WI, FLASHACCERR event

Table 39: Error reporting for flash access errors

For a Cortex-M33 master, the SecureFault exception will take precedence over the BusFault exception if a security violation occurs simultaneously with another type of violation.

6.15.2.3 UICR and FICR protections

The user information configuration registers (UICR) and factory information configuration registers (FICR) are always considered as secure. FICR registers are read-only. UICR registers can be read and written by secure code only.

Writing new values to user information configuration registers must follow the procedure described in [NVMC — Non-volatile memory controller](#) on page 31. Code execution from FICR and UICR address spaces will always be reported as access violation, an exception to this rule applies during a debug session.

6.15.3 RAM access control

The RAM memory space is divided in regions, each of them with configurable permissions settings.

The RAM memory space is divided into 32 regions of 8 KiB.

For each region, four different types of permissions can be configured:

Read

Allows data read access to the region. Code fetch from this region is not controlled by the read permission but by the execute permission described below.

Write

Allows write access to the region

Execute

Allows code fetch from this region

Secure

Allows only bus accesses with the security attribute set to access the region

Permissions can be set independently. For example, it is possible to configure a RAM region to be accessible only through secure transfer, being read-only (no write allowed) and non-executable (no code fetch allowed). For each region, permissions can be set and then locked to prevent subsequent modifications by using the [RAMREGION\[n\].PERM.LOCK](#) bit.

The following figure shows the RAM memory space and the divided regions:

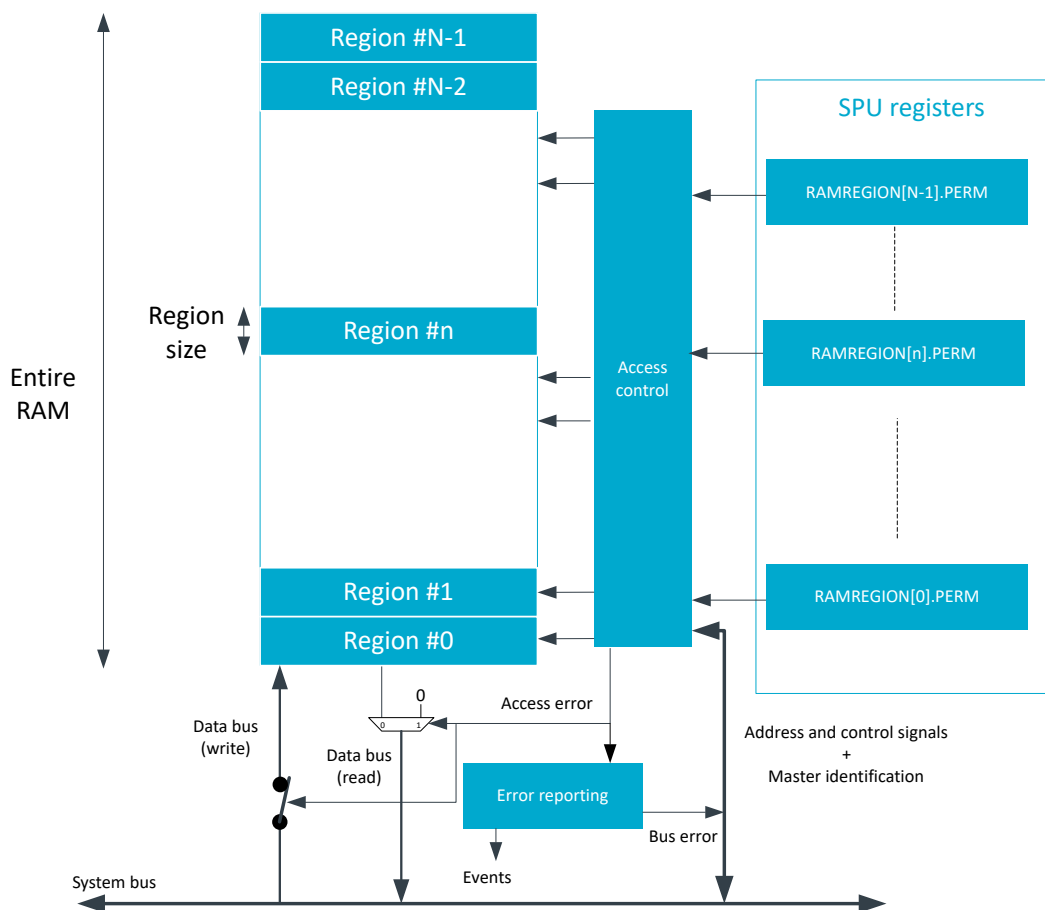

Figure 88: Definition of the $N=32$ regions, each of 8 KiB, in the RAM memory space

6.15.3.1 Non-secure callable (NSC) region definition in RAM

The SPU provides support for the definition of non-secure callable (NSC) sub-regions to allow non-secure to secure function calls.

A non-secure callable sub-region can only exist within an existing secure region and its definition is done using two registers:

- `RAMNSC[n].REGION`, used to select the secure region that will contain the NSC sub-region
- `RAMNSC[n].SIZE`, used to define the size of the NSC sub-region within the secure region

The NSC sub-region will be defined from the highest address in that region, going downwards. Figure below illustrates the NSC sub-regions and the registers used for their definition:

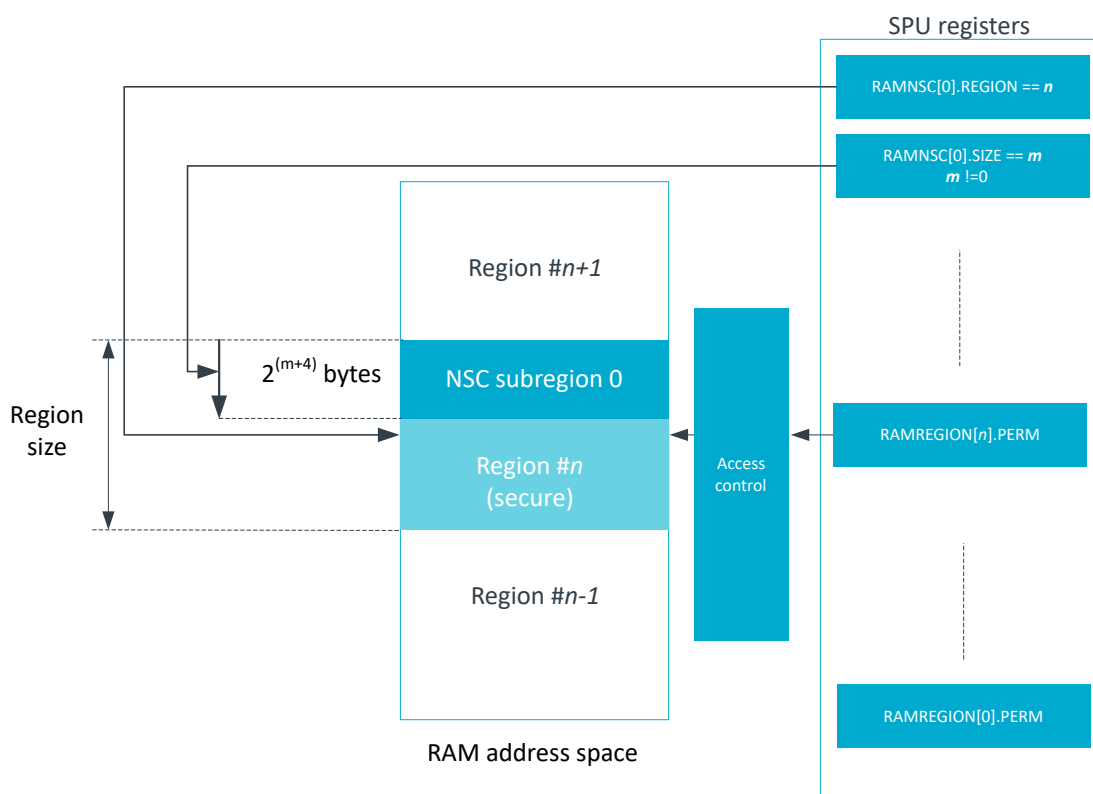

Figure 89: Non-secure callable region definition in the RAM memory space

The NSC sub-region will only be defined if:

- `RAMNSC[i].SIZE` value is non zero
- `RAMNSC[i].REGION` defines a secure region

If `RAMNSC[i].REGION` and `RAMNSC[j].REGION` have the same value, there is only one sub-region defined as NSC, with the size given by the maximum of `RAMNSC[i].SIZE` and `RAMNSC[j].SIZE`.

If `RAMNSC[i].REGION` defines a non-secure region, then there is no non-secure callable region defined and the selected region stays non-secure.

6.15.3.2 RAM access error reporting

The SPU and the logic controlled by it will respond with a certain behavior once an access violation is detected.

The following will happen once the logic controlled by the SPU detects an access violation on one of the RAM ports:

- The faulty transfer will be blocked
- In case of a read transfer, the bus will be driven to zero
- Feedback will be sent to the master through specific bus error signals, if this is supported by the master
- SecureFault exception will be triggered if security violation is detected for access from Cortex-M33
- BusFault exception will be triggered when read/write/execute protection violation is detected for Cortex-M33. The SPU will also generate an event that can optionally trigger an interrupt towards the CPU.
- RAMACCERR event will be triggered if any access violations are detected for all master types but for Cortex-M33 security violation

The following table summarizes the SPU behavior based on the type of initiator and access violation:

Master type	Security violation	Read/Write/Execute protection violation
Cortex-M33	SecureFault exception	BusFault exception, RAMACCERR event
EasyDMA	RAZ/WI, RAMACCERR event	RAZ/WI, RAMACCERR event
Other masters	RAZ/WI, RAMACCERR event	RAZ/WI, RAMACCERR event

Table 40: Error reporting for RAM access errors

For a Cortex-M33 master, the SecureFault exception will take precedence over the BusFault exception if a security violation occurs simultaneously with another type of violation.

6.15.4 Peripheral access control

Access controls are defined by the characteristics of the peripheral.

Peripherals can have their security attribute set as:

Always secure

For a peripheral related to system control

Always non-secure

For some general-purpose peripherals

Configurable

For general-purpose peripherals that may be configured for secure only access

The full list of peripherals and their corresponding security attributes can be found in [Memory map](#) on page 25. For each peripheral with ID n , `PERIPHID[n].PERM` will show whether the security attribute for this peripheral is configurable or not.

If not hardcoded, the security attribute can be configured using the `PERIPHID[id].PERM`.

At reset, all user-selectable and split security peripherals are set to be secure, with secure DMA where present.

Secure code can access both secure peripherals and non-secure peripherals.

6.15.4.1 Peripherals with split security

Peripherals with split security are defined to handle use-cases when both secure and non-secure code needs to control the same resource.

When peripherals with split security have their security attribute set to non-secure, access to specific registers and bitfields within some registers is dependent on the security attribute of the bus transfer. For example, some registers will not be accessible for a non-secure transfer.

When peripherals with split security have their security attribute set to secure, then only secure transfers can access their registers.

See [Instantiation](#) on page 27 for an overview of split security peripherals. Respective peripheral chapters explain the specific security behavior of each peripheral.

6.15.4.2 Peripheral address mapping

Peripherals that have non-secure security mapping have their address starting with `0x4XXX_XXXX`.

Peripherals that have secure security mapping have their address starting with `0x5XXX_XXXX`.

Peripherals with a user-selectable security mapping are available at an address starting with:

- `0x4XXX_XXXX`, if the peripheral security attribute is set to non-secure
- `0x5XXX_XXXX`, if the peripheral security attribute is set to secure

Note: Accesses to the 0x4XXX_XXXX address range from secure or non-secure code for a peripheral marked as secure will result in a bus-error.

Secure code accessing the 0x5XXX_XXXX address range of a peripheral marked as non-secure will also result in a bus-error.

Peripherals with a split security mapping are available at an address starting with:

- 0x4XXX_XXXX for non-secure access and 0x5XXX_XXXX for secure access, if the peripheral security attribute is set to non-secure
 - Secure registers in the 0x4XXX_XXXX range are not visible for secure or non-secure code, and an attempt to access such a register will result in write-ignore, read-as-zero behavior
 - Secure code can access both non-secure and secure registers in the 0x5XXX_XXXX range
- 0x5XXX_XXXX, if the peripheral security attribute is set to secure

Any attempt to access the 0x5000_0000-0x5FFF_FFFF address range from non-secure code will be ignored and generate a SecureFault exception.

The table below illustrates the address mapping for the three peripheral types, in all possible configurations

Security-features and configuration	Is mapped at 0x4XXX_XXXX?	Is mapped at 0x5XXX_XXXX?
Secure peripheral	No	Yes
Non-secure peripheral	Yes	No
Split-security peripheral, with attribute=secure	No	Yes
Split-security peripheral, with attribute=non-secure	Yes, restricted functionality	Yes

Table 41: Peripheral's address mapping in relation to its security-features and configuration

6.15.4.3 Special considerations for peripherals with DMA master

Peripherals containing a DMA master can be configured so the security attribute of the DMA transfers is different from the security attribute of the peripheral itself. This allows a secure peripheral to do non-secure data transfers to or from the system memories.

The following conditions must be met:

- The DMA field of `PERIPHID[n].PERM.SECURITYMAPPING` should read as "SeparateAttribute"
- The peripheral itself should be secure (`PERIPHID[n].PERM.SECATTR == 1`)

Then it is possible to select the security attribute of the DMA transfers using the field `DMASEC` (`PERIPHID[n].PERM.DMASEC == Secure` and `PERIPHID[n].PERM.DMASEC == NonSecure`) in `PERIPHID[n].PERM`.

6.15.4.4 Peripheral access error reporting

Peripherals send error reports once access violation is detected.

The following will happen if the logic controlled by the SPU detects an access violation on one of the peripherals:

- The faulty transfer will be blocked
- In case of a read transfer, the bus will be driven to zero
- Feedback is sent to the master through specific bus error signals, if this is supported by the master. If the master is a processor supporting ARM TrustZone for Cortex-M, a SecureFault exception will be generated for security related errors.
- The `PERIPHACCERR` event will be triggered

6.15.5 Pin access control

Access to device pins can be controlled by the SPU. A pin can be declared as secure so that only secure peripherals or secure code can access it. Pins declared as non-secure can be accessed by both secure and non-secure peripherals or code.

The security attribute of each pin can be individually configured in SPU's `GPIOPORT[n].PERM` register. When the secure attribute is set for a pin, only peripherals that have the secure attribute set will be able to read the value of the pin or change it.

Peripherals can select the pin(s) they need access to through their PSEL register(s). If a peripheral has its attribute set to non-secure, but one of its PSEL registers selects a pin with the attribute set to secure, the SPU controlled logic will ensure that the pin selection is not propagated. In addition, the pin value will always be read as zero, to prevent a non-secure peripheral from obtaining a value from a secure pin. Whereas access to other pins with attribute set as non-secure will not be blocked.

Pins can be assigned to other domains than the application domain by changing the MCUSEL value in the `GPIO PIN_CNFn` register. Domains that do not have a pin assigned to them can neither control that pin nor read its status. Any pin configuration set in a domain that doesn't have ownership of that pin will not take effect until the MCUSEL is updated to assign that pin to the domain. Within each domain, pin access is controlled by that domain's local security configuration and peripheral PSEL registers. This is illustrated in the following figure:

Note: The SPU setting will still count when the APP domain accesses its local GPIO peripheral, as local registers are still writable even though MCUSEL is set to a different domain. Any changes in the APP GPIO peripheral done to a GPIO controlled by another domain will not affect the GPIO pad until MCUSEL is changed to APP.

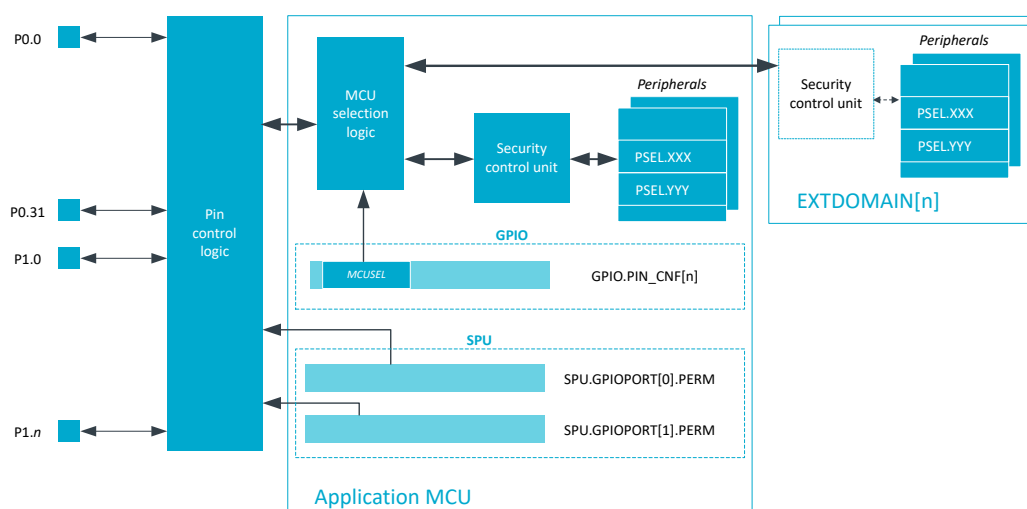

Figure 90: Pin access for domains other than the application domain

6.15.6 DPPI access control

Access to DPPI channels can be restricted. A channel can be declared as secure so that only secure peripherals can access it.

The security attribute of a DPPI channel is configured in `DPPI[n].PERM (n=0..0)` on page 341. When the secure attribute is set for a channel, only peripherals that have the secure attribute set will be able to publish events to this channel or subscribe to this channel to receive tasks.

The DPPI controller peripheral (DPPIC) is a split security peripheral, i.e., its security behavior depends on the security attributes of both the DPPIC and the accessing party. See [Special considerations regarding the DPPIC configuration registers](#) on page 334 for more information about the DPPIC security behavior.

If a non-secure peripheral wants to publish an event on a secure DPPI channel, the channel will ignore the event. If a non-secure peripheral subscribes to a secure DPPI channel, it will not receive any events from this channel. The following figure illustrates the principle of operation of the security logic for a subscribed channel:

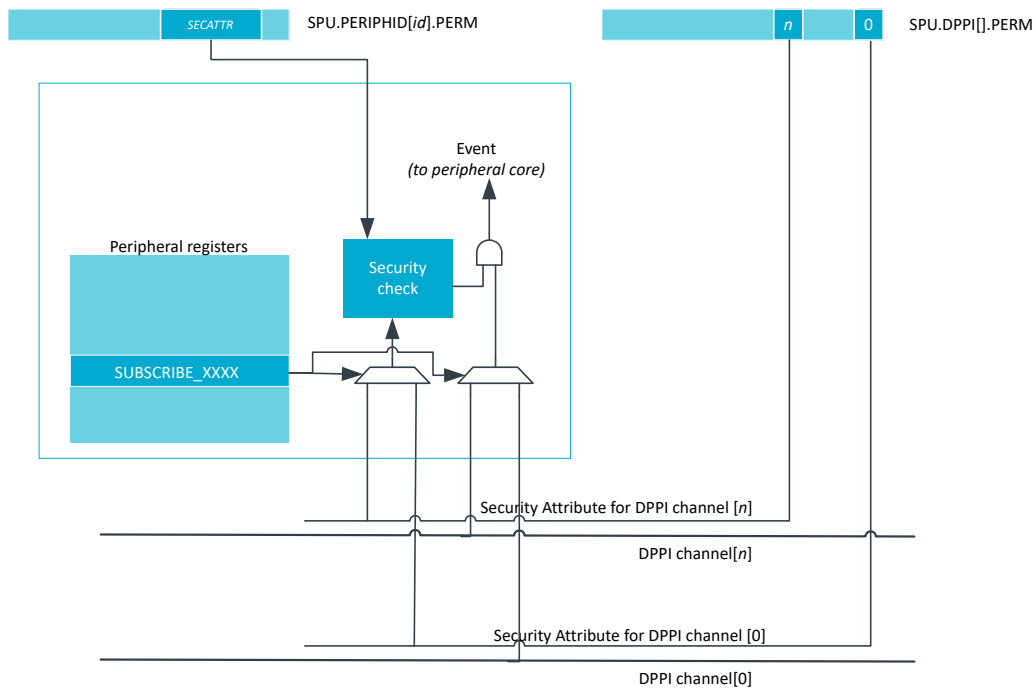

Figure 91: Subscribed channel security concept

No error reporting mechanism is associated with the DPPI access control logic.

6.15.6.1 Special considerations regarding the DPPIC configuration registers

DPPI channels can be enabled, disabled and grouped through the DPPIC controller (DPPIC). The DPPIC is a split-security peripheral, and handles both secure and non-secure accesses.

A non-secure peripheral access will only be able to configure and control DPPI channels defined as non-secure in SPU's `DPPI[n].PERM` register(s). A secure peripheral access can control all DPPI channels, independently of the configuration in the `DPPI[n].PERM` register(s).

The DPPIC allows the creation of group of channels to be able to enable or disable all channels within a group simultaneously. The security attribute of a group of channels (secure or non-secure) is defined as follows:

- If all channels (enabled or not) in the group are non-secure, then the group is considered non-secure
- If at least one of the channels (enabled or not) in the group is secure, then the group is considered secure

A non-secure access to a DPPIC register, or a bitfield controlling a channel marked as secure in `DPPI[n].PERM` register(s), will be ignored:

- Write accesses will have no effect
- Read will always return a zero value

No exceptions are thrown when a non-secure access targets a register or bitfield controlling a secure channel. For example, if the bit i is set in the `DPPI[n].PERM` register (declaring the DPPI channel i as secure), then:

- Non-secure write accesses to registers CHEN, CHENSET and CHENCLR will not be able to write to bit i of those registers
- Non-secure write accesses to registers TASK_CHG[j].EN and TASK_CHG[j].DIS will be ignored if the channel group j contains at least one channel defined as secure (it can be the channel i itself or any channel declared as secured)
- Non-secure read accesses to registers CHEN, CHENSET and CHENCLR will always read zero for the bit at position i

For the channel configuration registers (DPPIC.CHG[n]), access from non-secure code is only possible if the included channels are all non-secure, whether the channels are enabled or not. If a DPPIC.CHG[g] register included one or more secure channels, then the group g is considered as secure and only a secure transfer can read or write DPPIC.CHG[g]. A non-secure write will be ignored and a non-secure read will return zero.

The DPPIC can subscribe to secure or non-secure channels through SUBSCRIBE_CHG[n] registers in order to trigger task for enabling or disabling groups of channels. But an event from a non-secure channel will be ignored if the group subscribing to this channel is secure. An event from a secure channel can trigger both secure and non-secure tasks.

6.15.7 External domain access control

Other domains with their own CPUs can access peripherals, flash, and RAM memories. The SPU allows controlling accesses from those bus masters.

The external domains can access application MCU memories and peripherals. External domains are assigned security attributes as described in register EXTDOMAIN[n].PERM.

Domain	Capability register	Permission register
LTE modem	Modem is always a non-secure domain	Not applicable

Table 42: Register mapping for external domains

The figure below illustrates how the security control units are used to assign security attributes to transfers initiated by the external domains:

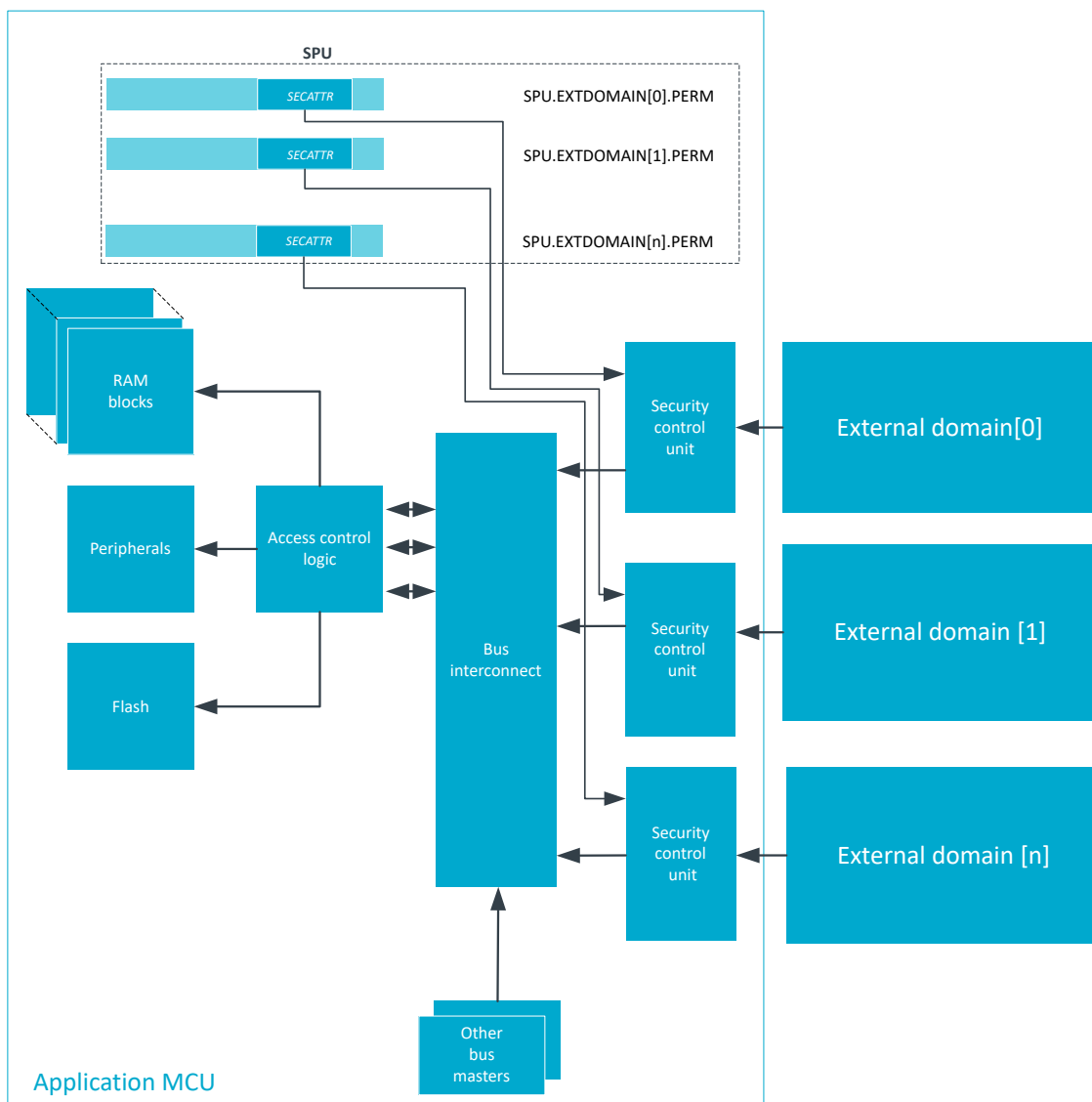

Figure 92: Access control from external domains

6.15.8 TrustZone for Cortex-M ID allocation

Flash and RAM regions, as well as non-secure and secure peripherals, are assigned unique TrustZone IDs.

Note: TrustZone ID should not be confounded with the peripheral ID used to identify peripherals.

The table below shows the TrustZone ID allocation:

Regions	TrustZone Cortex-M ID
Flash regions 0..31	0..31
RAM regions 0..15	64..79
Non-secure peripherals	253
Secure peripherals	254

Table 43: TrustZone ID allocation

6.15.9 Registers

Instances

Instance	Base address	TrustZone			Split access	Description
		Map	Att	DMA		
SPU	0x50003000	HF	S	NA	No	System Protection Unit

Register overview

Register	Offset	TZ	Description
EVENTS_RAMACCERR	0x100		A security violation has been detected for the RAM memory space
EVENTS_FLASHACCERR	0x104		A security violation has been detected for the flash memory space
EVENTS_PERIPHACCERR	0x108		A security violation has been detected on one or several peripherals
PUBLISH_RAMACCERR	0x180		Publish configuration for event RAMACCERR
PUBLISH_FLASHACCERR	0x184		Publish configuration for event FLASHACCERR
PUBLISH_PERIPHACCERR	0x188		Publish configuration for event PERIPHACCERR
INTEN	0x300		Enable or disable interrupt
INTENSET	0x304		Enable interrupt
INTENCLR	0x308		Disable interrupt
CAP	0x400		Show implemented features for the current device
EXTDOMAIN[n].PERM	0x440		Access for bus access generated from the external domain n List capabilities of the external domain n
DPPI[n].PERM	0x480		Select between secure and non-secure attribute for the DPPI channels.
DPPI[n].LOCK	0x484		Prevent further modification of the corresponding PERM register
GPIOPORT[n].PERM	0x4C0		Select between secure and non-secure attribute for pins 0 to 31 of port n. This register is retained.
GPIOPORT[n].LOCK	0x4C4		Prevent further modification of the corresponding PERM register
FLASHNSC[n].REGION	0x500		Define which flash region can contain the non-secure callable (NSC) region n
FLASHNSC[n].SIZE	0x504		Define the size of the non-secure callable (NSC) region n
RAMNSC[n].REGION	0x540		Define which RAM region can contain the non-secure callable (NSC) region n
RAMNSC[n].SIZE	0x544		Define the size of the non-secure callable (NSC) region n
FLASHREGION[n].PERM	0x600		Access permissions for flash region n
RAMREGION[n].PERM	0x700		Access permissions for RAM region n
PERIPHID[n].PERM	0x800		List capabilities and access permissions for the peripheral with ID n

6.15.9.1 EVENTS_RAMACCERR

Address offset: 0x100

A security violation has been detected for the RAM memory space

Bit number	31 30 29 28 27 26 25 24 23 22 21 20 19 18 17 16 15 14 13 12 11 10 9 8 7 6 5 4 3 2 1 0																														
ID	A																														
Reset 0x00000000	0 0																														
ID	R/W	Field	Value ID	Value	Description																										
A	RW	EVENTS_RAMACCERR			A security violation has been detected for the RAM memory space																										
			NotGenerated	0	Event not generated																										
			Generated	1	Event generated																										

6.15.9.2 EVENTS_FLASHACCERR

Address offset: 0x104

A security violation has been detected for the flash memory space

Bit number	31 30 29 28 27 26 25 24 23 22 21 20 19 18 17 16 15 14 13 12 11 10 9 8 7 6 5 4 3 2 1 0																														
ID	A																														
Reset 0x00000000	0 0																														
ID	R/W	Field	Value ID	Value	Description																										
A	RW	EVENTS_FLASHACCERR			A security violation has been detected for the flash memory space																										
			NotGenerated	0	Event not generated																										
			Generated	1	Event generated																										

6.15.9.3 EVENTS_PERIPHACCERR

Address offset: 0x108

A security violation has been detected on one or several peripherals

Bit number	31 30 29 28 27 26 25 24 23 22 21 20 19 18 17 16 15 14 13 12 11 10 9 8 7 6 5 4 3 2 1 0																														
ID	A																														
Reset 0x00000000	0 0																														
ID	R/W	Field	Value ID	Value	Description																										
A	RW	EVENTS_PERIPHACCERR			A security violation has been detected on one or several peripherals																										
			NotGenerated	0	Event not generated																										
			Generated	1	Event generated																										

6.15.9.4 PUBLISH_RAMACCERR

Address offset: 0x180

Publish configuration for event [RAMACCERR](#)

Bit number	31 30 29 28 27 26 25 24 23 22 21 20 19 18 17 16 15 14 13 12 11 10 9 8 7 6 5 4 3 2 1 0																														
ID	B																														
Reset 0x00000000	0 0																														
ID	R/W	Field	Value ID	Value	Description																										
A	RW	CHIDX		[0..255]	DPPI channel that event RAMACCERR will publish to																										
B	RW	EN																													
			Disabled	0	Disable publishing																										
			Enabled	1	Enable publishing																										

6.15.9.5 PUBLISH_FLASHACCERR

Address offset: 0x184

Publish configuration for event [FLASHACCERR](#)

Bit number	31	30	29	28	27	26	25	24	23	22	21	20	19	18	17	16	15	14	13	12	11	10	9	8	7	6	5	4	3	2	1	0																						
ID	B																							A				A	A	A	A	A	A	A	A	A	A	A	A	A	A	A	A	A	A	A	A	A	A	A	A	A	A	A
Reset 0x00000000	0 0																																																					
ID	R/W	Field	Value ID	Value	Description																																																	
A	RW	CHIDX		[0..255]	DPPI channel that event FLASHACCERR will publish to																																																	
B	RW	EN	Disabled	0	Disable publishing																																																	
			Enabled	1	Enable publishing																																																	

6.15.9.6 PUBLISH_PERIPHACCERR

Address offset: 0x188

Publish configuration for event [PERIPHACCERR](#)

Bit number	31	30	29	28	27	26	25	24	23	22	21	20	19	18	17	16	15	14	13	12	11	10	9	8	7	6	5	4	3	2	1	0																					
ID	B																							A				A	A	A	A	A	A	A	A	A	A	A	A	A	A	A	A	A	A	A	A	A	A	A	A	A	A
Reset 0x00000000	0 0																																																				
ID	R/W	Field	Value ID	Value	Description																																																
A	RW	CHIDX		[0..255]	DPPI channel that event PERIPHACCERR will publish to																																																
B	RW	EN	Disabled	0	Disable publishing																																																
			Enabled	1	Enable publishing																																																

6.15.9.7 INTEN

Address offset: 0x300

Enable or disable interrupt

Bit number	31	30	29	28	27	26	25	24	23	22	21	20	19	18	17	16	15	14	13	12	11	10	9	8	7	6	5	4	3	2	1	0																		
ID																								C		B	A																							
Reset 0x00000000	0 0																																																	
ID	R/W	Field	Value ID	Value	Description																																													
A	RW	RAMACCERR			Enable or disable interrupt for event RAMACCERR																																													
			Disabled	0	Disable																																													
			Enabled	1	Enable																																													
			B	RW	FLASHACCERR			Enable or disable interrupt for event FLASHACCERR																																										
Disabled	0	Disable																																																
			Enabled	1	Enable																																													
			C	RW	PERIPHACCERR			Enable or disable interrupt for event PERIPHACCERR																																										
Disabled	0	Disable																																																
			Enabled	1	Enable																																													

6.15.9.8 INTENSET

Address offset: 0x304

Enable interrupt

Bit number	31 30 29 28 27 26 25 24 23 22 21 20 19 18 17 16 15 14 13 12 11 10 9 8 7 6 5 4 3 2 1 0																																
ID																															C	B	A
Reset 0x00000000	0 0																																
ID	R/W	Field	Value ID	Value	Description																												
A	RW	RAMACCERR			Write '1' to enable interrupt for event RAMACCERR																												
			Set	1	Enable																												
			Disabled	0	Read: Disabled																												
			Enabled	1	Read: Enabled																												
B	RW	FLASHACCERR			Write '1' to enable interrupt for event FLASHACCERR																												
			Set	1	Enable																												
			Disabled	0	Read: Disabled																												
			Enabled	1	Read: Enabled																												
C	RW	PERIPHACCERR			Write '1' to enable interrupt for event PERIPHACCERR																												
			Set	1	Enable																												
			Disabled	0	Read: Disabled																												
			Enabled	1	Read: Enabled																												

6.15.9.9 INTENCLR

Address offset: 0x308

Disable interrupt

Bit number	31 30 29 28 27 26 25 24 23 22 21 20 19 18 17 16 15 14 13 12 11 10 9 8 7 6 5 4 3 2 1 0																																
ID																															C	B	A
Reset 0x00000000	0 0																																
ID	R/W	Field	Value ID	Value	Description																												
A	RW	RAMACCERR			Write '1' to disable interrupt for event RAMACCERR																												
			Clear	1	Disable																												
			Disabled	0	Read: Disabled																												
			Enabled	1	Read: Enabled																												
B	RW	FLASHACCERR			Write '1' to disable interrupt for event FLASHACCERR																												
			Clear	1	Disable																												
			Disabled	0	Read: Disabled																												
			Enabled	1	Read: Enabled																												
C	RW	PERIPHACCERR			Write '1' to disable interrupt for event PERIPHACCERR																												
			Clear	1	Disable																												
			Disabled	0	Read: Disabled																												
			Enabled	1	Read: Enabled																												

6.15.9.10 CAP

Address offset: 0x400

Show implemented features for the current device

Bit number	31 30 29 28 27 26 25 24 23 22 21 20 19 18 17 16 15 14 13 12 11 10 9 8 7 6 5 4 3 2 1 0																															
ID																															A	
Reset 0x00000001	0 1																															
ID	R/W	Field	Value ID	Value	Description																											
A	R	TZM			Show ARM TrustZone status																											
			NotAvailable	0	ARM TrustZone support not available																											
			Enabled	1	ARM TrustZone support is available																											

Bit number	31	30	29	28	27	26	25	24	23	22	21	20	19	18	17	16	15	14	13	12	11	10	9	8	7	6	5	4	3	2	1	0	
ID																																A	
Reset	0x00000000																																
0	0	0	0	0	0	0	0	0	0	0	0	0	0	0	0	0	0	0	0	0	0	0	0	0	0	0	0	0	0	0	0	0	0
ID	R/W	Field	Value ID	Value	Description																												
A	RW	LOCK																															
			Locked	1	DPPI[n].PERM register can't be changed until next reset																												
			Unlocked	0	DPPI[n].PERM register content can be changed																												

6.15.9.14 GPIOPORT[n].PERM (n=0..0) (Retained)

Address offset: $0x4C0 + (n \times 0x8)$

Select between secure and non-secure attribute for pins 0 to 31 of port n.

This register is retained.

Bit number	31	30	29	28	27	26	25	24	23	22	21	20	19	18	17	16	15	14	13	12	11	10	9	8	7	6	5	4	3	2	1	0
ID	f	e	d	c	b	a	Z	Y	X	W	V	U	T	S	R	Q	P	O	N	M	L	K	J	I	H	G	F	E	D	C	B	A
Reset	0xFFFFFFFF																															
1	1	1	1	1	1	1	1	1	1	1	1	1	1	1	1	1	1	1	1	1	1	1	1	1	1	1	1	1	1	1	1	1
ID	R/W	Field	Value ID	Value	Description																											
A-f	RW	PIN[i] (i=0..31)			Select secure attribute attribute for PIN i.																											
			Secure	1	Pin i has its secure attribute set																											
			NonSecure	0	Pin i has its non-secure attribute set																											

6.15.9.15 GPIOPORT[n].LOCK (n=0..0)

Address offset: $0x4C4 + (n \times 0x8)$

Prevent further modification of the corresponding PERM register

Bit number	31	30	29	28	27	26	25	24	23	22	21	20	19	18	17	16	15	14	13	12	11	10	9	8	7	6	5	4	3	2	1	0
ID																																A
Reset	0x00000000																															
0	0	0	0	0	0	0	0	0	0	0	0	0	0	0	0	0	0	0	0	0	0	0	0	0	0	0	0	0	0	0	0	0
ID	R/W	Field	Value ID	Value	Description																											
A	RW	LOCK																														
			Locked	1	GPIOPORT[n].PERM register can't be changed until next reset																											
			Unlocked	0	GPIOPORT[n].PERM register content can be changed																											

6.15.9.16 FLASHNSC[n].REGION (n=0..1)

Address offset: $0x500 + (n \times 0x8)$

Define which flash region can contain the non-secure callable (NSC) region n

Bit number	31	30	29	28	27	26	25	24	23	22	21	20	19	18	17	16	15	14	13	12	11	10	9	8	7	6	5	4	3	2	1	0
ID																									B	A			A	A	A	A
Reset	0x00000000																															
0	0	0	0	0	0	0	0	0	0	0	0	0	0	0	0	0	0	0	0	0	0	0	0	0	0	0	0	0	0	0	0	0
ID	R/W	Field	Value ID	Value	Description																											
A-	RW	REGION			Region number																											
B	RW	LOCK																														
			Unlocked	0	This register can be updated																											
			Locked	1	The content of this register can't be changed until the next reset																											

6.15.9.17 FLASHNSC[n].SIZE (n=0..1)

Address offset: $0x504 + (n \times 0x8)$

Define the size of the non-secure callable (NSC) region n

Bit number	31 30 29 28 27 26 25 24 23 22 21 20 19 18 17 16 15 14 13 12 11 10 9 8 7 6 5 4 3 2 1 0																																							
ID																									B				A			A			A			A		
Reset 0x00000000	0 0																																							
ID	R/W	Field	Value ID	Value	Description																																			
A	RW	SIZE			Size of the non-secure callable (NSC) region n																																			
			Disabled	0	The region n is not defined as a non-secure callable region. Normal security attributes (secure or non-secure) are enforced.																																			
			32	1	The region n is defined as non-secure callable with a 32-byte size																																			
			64	2	The region n is defined as non-secure callable with a 64-byte size																																			
			128	3	The region n is defined as non-secure callable with a 128-byte size																																			
			256	4	The region n is defined as non-secure callable with a 256-byte size																																			
			512	5	The region n is defined as non-secure callable with a 512-byte size																																			
			1024	6	The region n is defined as non-secure callable with a 1024-byte size																																			
			2048	7	The region n is defined as non-secure callable with a 2048-byte size																																			
			4096	8	The region n is defined as non-secure callable with a 4096-byte size																																			
B	RW	LOCK																																						
			Unlocked	0	This register can be updated																																			
			Locked	1	The content of this register can't be changed until the next reset																																			

6.15.9.18 RAMNSC[n].REGION (n=0..1)

Address offset: $0x540 + (n \times 0x8)$

Define which RAM region can contain the non-secure callable (NSC) region n

Bit number	31 30 29 28 27 26 25 24 23 22 21 20 19 18 17 16 15 14 13 12 11 10 9 8 7 6 5 4 3 2 1 0																																							
ID																									B				A			A			A			A		
Reset 0x00000000	0 0																																							
ID	R/W	Field	Value ID	Value	Description																																			
A-	RW	REGION			Region number																																			
B	RW	LOCK																																						
			Unlocked	0	This register can be updated																																			
			Locked	1	The content of this register can't be changed until the next reset																																			

6.15.9.19 RAMNSC[n].SIZE (n=0..1)

Address offset: $0x544 + (n \times 0x8)$

Define the size of the non-secure callable (NSC) region n

Bit number	31 30 29 28 27 26 25 24 23 22 21 20 19 18 17 16 15 14 13 12 11 10 9 8 7 6 5 4 3 2 1 0																																				
ID																									B				A			A			A		
Reset 0x00000000	0 0																																				
ID	R/W	Field	Value ID	Value	Description																																
A	RW	SIZE			Size of the non-secure callable (NSC) region n																																
			Disabled	0	The region n is not defined as a non-secure callable region. Normal security attributes (secure or non-secure) are enforced.																																
			32	1	The region n is defined as non-secure callable with a 32-byte size																																
			64	2	The region n is defined as non-secure callable with a 64-byte size																																
			128	3	The region n is defined as non-secure callable with a 128-byte size																																
			256	4	The region n is defined as non-secure callable with a 256-byte size																																
			512	5	The region n is defined as non-secure callable with a 512-byte size																																

Bit number	31 30 29 28 27 26 25 24 23 22 21 20 19 18 17 16 15 14 13 12 11 10 9 8 7 6 5 4 3 2 1 0																																	
ID																												B			A	A	A	A
Reset 0x00000000	0 0																																	
ID	R/W	Field	Value ID	Value	Description																													
			1024	6	The region n is defined as non-secure callable with a 1024-byte size																													
			2048	7	The region n is defined as non-secure callable with a 2048-byte size																													
			4096	8	The region n is defined as non-secure callable with a 4096-byte size																													
B	RW	LOCK																																
			Unlocked	0	This register can be updated																													
			Locked	1	The content of this register can't be changed until the next reset																													

6.15.9.20 FLASHREGION[n].PERM (n=0..31)

Address offset: 0x600 + (n × 0x4)

Access permissions for flash region n

Bit number	31 30 29 28 27 26 25 24 23 22 21 20 19 18 17 16 15 14 13 12 11 10 9 8 7 6 5 4 3 2 1 0																																	
ID																												E		D		C	B	A
Reset 0x00000017	0 1 0 1 1 1																																	
ID	R/W	Field	Value ID	Value	Description																													
A	RW	EXECUTE			Configure instruction fetch permissions from flash region n																													
			Enable	1	Allow instruction fetches from flash region n																													
			Disable	0	Block instruction fetches from flash region n																													
B	RW	WRITE			Configure write permission for flash region n																													
			Enable	1	Allow write operation to region n																													
			Disable	0	Block write operation to region n																													
C	RW	READ			Configure read permissions for flash region n																													
			Enable	1	Allow read operation from flash region n																													
			Disable	0	Block read operation from flash region n																													
D	RW	SECATTR			Security attribute for flash region n																													
			Non_Secure	0	Flash region n security attribute is non-secure																													
			Secure	1	Flash region n security attribute is secure																													
E	RW	LOCK																																
			Unlocked	0	This register can be updated																													
			Locked	1	The content of this register can't be changed until the next reset																													

6.15.9.21 RAMREGION[n].PERM (n=0..31)

Address offset: 0x700 + (n × 0x4)

Access permissions for RAM region n

Bit number	31 30 29 28 27 26 25 24 23 22 21 20 19 18 17 16 15 14 13 12 11 10 9 8 7 6 5 4 3 2 1 0																																	
ID																												E		D		C	B	A
Reset 0x00000017	0 1 0 1 1 1																																	
ID	R/W	Field	Value ID	Value	Description																													
A	RW	EXECUTE			Configure instruction fetch permissions from RAM region n																													
			Enable	1	Allow instruction fetches from RAM region n																													
			Disable	0	Block instruction fetches from RAM region n																													
B	RW	WRITE			Configure write permission for RAM region n																													
			Enable	1	Allow write operation to RAM region n																													
			Disable	0	Block write operation to RAM region n																													
C	RW	READ			Configure read permissions for RAM region n																													
			Enable	1	Allow read operation from RAM region n																													

Bit number	31 30 29 28 27 26 25 24 23 22 21 20 19 18 17 16 15 14 13 12 11 10 9 8 7 6 5 4 3 2 1 0																																	
ID																												E	D			C	B	A
Reset 0x00000017	0 1 0 1 1 1																																	
ID	R/W	Field	Value ID	Value	Description																													
			Disable	0	Block read operation from RAM region n																													
D	RW	SECATTR			Security attribute for RAM region n																													
			Non_Secure	0	RAM region n security attribute is non-secure																													
			Secure	1	RAM region n security attribute is secure																													
E	RW	LOCK																																
			Unlocked	0	This register can be updated																													
			Locked	1	The content of this register can't be changed until the next reset																													

6.15.9.22 PERIPHID[n].PERM (n=0..66)

Address offset: 0x800 + (n × 0x4)

List capabilities and access permissions for the peripheral with ID n

Note: Reset values are unique per peripheral instantiation. Please refer to the peripheral instantiation table. Entries not listed in the instantiation table are undefined.

Bit number	31 30 29 28 27 26 25 24 23 22 21 20 19 18 17 16 15 14 13 12 11 10 9 8 7 6 5 4 3 2 1 0																																			
ID	F																											E	D			C	B	B	A	A
Reset 0x00000012	0 1 0 0 1 0																																			
ID	R/W	Field	Value ID	Value	Description																															
A	R	SECUREMAPPING			Define configuration capabilities for TrustZone Cortex-M secure attribute																															
			NonSecure	0	This peripheral is always accessible as a non-secure peripheral																															
			Secure	1	This peripheral is always accessible as a secure peripheral																															
			UserSelectable	2	Non-secure or secure attribute for this peripheral is defined by the PERIPHID[n].PERM register																															
			Split	3	This peripheral implements the split security mechanism. Non-secure or secure attribute for this peripheral is defined by the PERIPHID[n].PERM register.																															
B	R	DMA			Indicate if the peripheral has DMA capabilities and if DMA transfer can be assigned to a different security attribute than the peripheral itself																															
			NoDMA	0	Peripheral has no DMA capability																															
			NoSeparateAttribute	1	Peripheral has DMA and DMA transfers always have the same security attribute as assigned to the peripheral																															
			SeparateAttribute	2	Peripheral has DMA and DMA transfers can have a different security attribute than the one assigned to the peripheral																															
C	RW	SECATTR			Peripheral security mapping																															
			Secure	1	Peripheral is mapped in secure peripheral address space																															
			NonSecure	0	If SECUREMAPPING == UserSelectable: Peripheral is mapped in non-secure peripheral address space. If SECUREMAPPING == Split: Peripheral is mapped in non-secure and secure peripheral address space.																															

Note: This bit has effect only if PERIPHID[n].PERM.SECUREMAPPING reads as UserSelectable or Split

Bit number	31 30 29 28 27 26 25 24 23 22 21 20 19 18 17 16 15 14 13 12 11 10 9 8 7 6 5 4 3 2 1 0																														
ID	F															E															
Reset 0x00000012																															
0 1 0 0 1 0																															
ID	R/W	Field	Value ID	Value	Description																										
D	RW	DMASEC			Security attribution for the DMA transfer																										
					Note: This bit has effect only if PERIPHID[n].PERM.SECATTR is set to secure																										
			Secure	1	DMA transfers initiated by this peripheral have the secure attribute set																										
			NonSecure	0	DMA transfers initiated by this peripheral have the non-secure attribute set																										
E	RW	LOCK																													
			Unlocked	0	This register can be updated																										
			Locked	1	The content of this register can't be changed until the next reset																										
F	R	PRESENT			Indicate if a peripheral is present with ID n																										
			NotPresent	0	Peripheral is not present																										
			IsPresent	1	Peripheral is present																										

6.16 TIMER — Timer/counter

This peripheral is a general purpose timer designed to keep track of time in user-selective time intervals, it can operate in two modes: timer and counter.

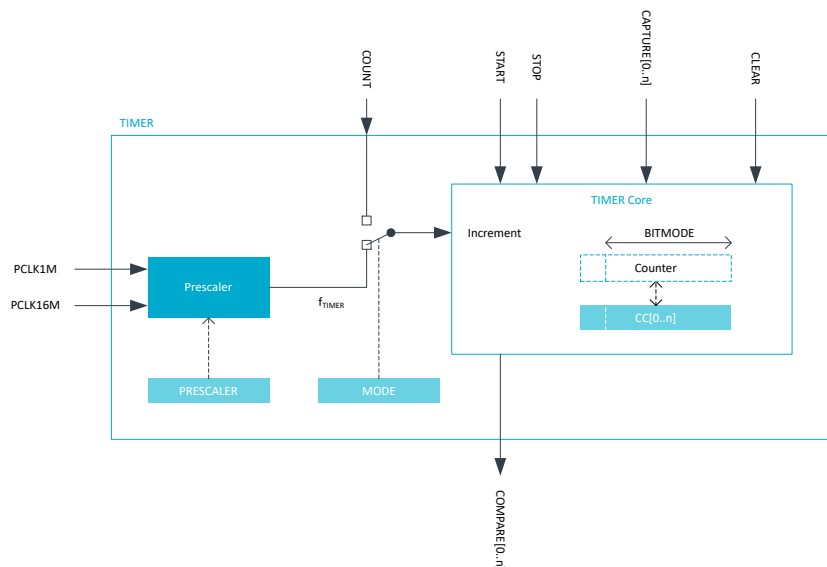

Figure 93: Block schematic for timer/counter

The timer/counter runs on the high-frequency clock source (HFCLK) and includes a four-bit (1/2X) prescaler that can divide the timer input clock from the HFCLK controller. Clock source selection between PCLK16M and PCLK1M is automatic according to TIMER base frequency set by the prescaler. The TIMER base frequency is always given as 16 MHz divided by the prescaler value.

The PPI system allows a TIMER event to trigger a task of any other system peripheral of the device. The PPI system also enables the TIMER task/event features to generate periodic output and PWM signals to any GPIO. The number of input/outputs used at the same time is limited by the number of GPIOTE channels.

TIMER can operate in two modes: Timer mode and Counter mode. In both modes, TIMER is started by triggering the START task, and stopped by triggering the STOP task. After the timer is stopped the timer can resume timing/counting by triggering the START task again. When timing/counting is resumed, the timer will continue from the value it had prior to being stopped.

In Timer mode, the TIMER's internal Counter register is incremented by one for every tick of the timer frequency f_{TIMER} as illustrated in [Block schematic for timer/counter](#) on page 346. The timer frequency is derived from PCLK16M as shown in the following example, using the values specified in the PRESCALER register.

$$f_{\text{TIMER}} = 16 \text{ MHz} / (2^{\text{PRESCALER}})$$

When $f_{\text{TIMER}} \leq 1 \text{ MHz}$, TIMER will use PCLK1M instead of PCLK16M for reduced power consumption.

In counter mode, the TIMER's internal Counter register is incremented by one each time the COUNT task is triggered, meaning the timer frequency and the prescaler are not utilized in counter mode. Similarly, the COUNT task has no effect in Timer mode.

The TIMER's maximum value is configured by changing the bit-width of the timer in register [BITMODE](#) on page 353.

[PRESCALER](#) on page 354 and [BITMODE](#) on page 353 must only be updated when the timer is stopped. If these registers are updated while the timer is started, unpredictable behavior may occur.

When the timer is incremented beyond its maximum value, the Counter register will overflow and the timer will automatically start over from zero.

The Counter register can be cleared by triggering the CLEAR task. This will explicitly set the internal value to zero.

TIMER implements multiple capture/compare registers.

Independent of prescaler setting, the accuracy of TIMER is equivalent to one tick of the timer frequency f_{TIMER} as illustrated in [Block schematic for timer/counter](#) on page 346.

6.16.1 Capture

TIMER implements one capture task for every available capture/compare register.

Every time the CAPTURE[n] task is triggered, the Counter value is copied to the CC[n] register.

6.16.2 Compare

TIMER implements one COMPARE event for every available capture/compare register.

A COMPARE event is generated when the Counter is incremented and then becomes equal to the value specified in one of the capture compare registers. When the Counter value becomes equal to the value specified in a capture compare register CC[n], the corresponding compare event COMPARE[n] is generated.

[BITMODE](#) on page 353 specifies how many bits of the Counter register and the capture/compare register that are used when the comparison is performed. Other bits will be ignored.

The COMPARE event can be configured to operate in one-shot mode by configuring the corresponding ONESHOTEN[n] register. COMPARE[n] event is generated the first time the Counter matches CC[n] after CC[n] has been written.

6.16.3 Task delays

After TIMER is started, the CLEAR, COUNT, and STOP tasks are guaranteed to take effect within one clock cycle of the PCLK16M.

6.16.4 Task priority

If the START task and the STOP task are triggered at the same time, meaning within the same period of PCLK16M, the STOP task will be prioritized.

If one or more of the CAPTURE tasks and the CLEAR task is triggered at the same time, that is, within the same period of PCLK16M, the CLEAR task will be prioritized. This means that the CC register for the relevant CAPTURE task will be set to 0.

6.16.5 Registers

Instances

Instance	Base address	TrustZone			Split access	Description
		Map	Att	DMA		
TIMERO : S	0x5000F000	US	NS	NA	No	Timer 0
TIMERO : NS	0x4000F000					
TIMER1 : S	0x50010000	US	NS	NA	No	Timer 1
TIMER1 : NS	0x40010000					
TIMER2 : S	0x50011000	US	NS	NA	No	Timer 2
TIMER2 : NS	0x40011000					

Register overview

Register	Offset	TZ	Description
TASKS_START	0x000		Start Timer
TASKS_STOP	0x004		Stop Timer
TASKS_COUNT	0x008		Increment Timer (Counter mode only)
TASKS_CLEAR	0x00C		Clear time
TASKS_SHUTDOWN	0x010		Shut down timer
			This register is deprecated.
TASKS_CAPTURE[n]	0x040		Capture Timer value to CC[n] register
SUBSCRIBE_START	0x080		Subscribe configuration for task START
SUBSCRIBE_STOP	0x084		Subscribe configuration for task STOP
SUBSCRIBE_COUNT	0x088		Subscribe configuration for task COUNT
SUBSCRIBE_CLEAR	0x08C		Subscribe configuration for task CLEAR
SUBSCRIBE_SHUTDOWN	0x090		Subscribe configuration for task SHUTDOWN
			This register is deprecated.
SUBSCRIBE_CAPTURE[n]	0x0C0		Subscribe configuration for task CAPTURE[n]
EVENTS_COMPARE[n]	0x140		Compare event on CC[n] match
PUBLISH_COMPARE[n]	0x1C0		Publish configuration for event COMPARE[n]
SHORTS	0x200		Shortcuts between local events and tasks
INTENSET	0x304		Enable interrupt
INTENCLR	0x308		Disable interrupt
MODE	0x504		Timer mode selection
BITMODE	0x508		Configure the number of bits used by the TIMER
PRESCALER	0x510		Timer prescaler register
ONESHOTEN[n]	0x514		Enable one-shot operation for Capture/Compare channel n
CC[n]	0x540		Capture/Compare register n

6.16.5.1 TASKS_START

Address offset: 0x000

Start Timer

Bit number	31	30	29	28	27	26	25	24	23	22	21	20	19	18	17	16	15	14	13	12	11	10	9	8	7	6	5	4	3	2	1	0
ID																																A
Reset 0x00000000	0 0																															
ID	R/W	Field	Value ID	Value	Description																											
A	W	TASKS_START			Start Timer																											
			Trigger	1	Trigger task																											

6.16.5.2 TASKS_STOP

Address offset: 0x004

Stop Timer

Bit number	31	30	29	28	27	26	25	24	23	22	21	20	19	18	17	16	15	14	13	12	11	10	9	8	7	6	5	4	3	2	1	0
ID																																A
Reset 0x00000000	0 0																															
ID	R/W	Field	Value ID	Value	Description																											
A	W	TASKS_STOP			Stop Timer																											
			Trigger	1	Trigger task																											

6.16.5.3 TASKS_COUNT

Address offset: 0x008

Increment Timer (Counter mode only)

Bit number	31	30	29	28	27	26	25	24	23	22	21	20	19	18	17	16	15	14	13	12	11	10	9	8	7	6	5	4	3	2	1	0
ID																																A
Reset 0x00000000	0 0																															
ID	R/W	Field	Value ID	Value	Description																											
A	W	TASKS_COUNT			Increment Timer (Counter mode only)																											
			Trigger	1	Trigger task																											

6.16.5.4 TASKS_CLEAR

Address offset: 0x00C

Clear time

Bit number	31	30	29	28	27	26	25	24	23	22	21	20	19	18	17	16	15	14	13	12	11	10	9	8	7	6	5	4	3	2	1	0
ID																																A
Reset 0x00000000	0 0																															
ID	R/W	Field	Value ID	Value	Description																											
A	W	TASKS_CLEAR			Clear time																											
			Trigger	1	Trigger task																											

6.16.5.5 TASKS_SHUTDOWN (Deprecated)

Address offset: 0x010

Shut down timer

This register is deprecated.

Bit number	31 30 29 28 27 26 25 24 23 22 21 20 19 18 17 16 15 14 13 12 11 10 9 8 7 6 5 4 3 2 1 0																														
ID	A																														
Reset 0x00000000	0 0																														
ID	R/W	Field	Value ID	Value	Description																										
A	W	TASKS_SHUTDOWN			Shut down timer																										
					This field is deprecated.																										
			Trigger	1	Trigger task																										

6.16.5.6 TASKS_CAPTURE[n] (n=0..5)

Address offset: 0x040 + (n × 0x4)

Capture Timer value to CC[n] register

Bit number	31 30 29 28 27 26 25 24 23 22 21 20 19 18 17 16 15 14 13 12 11 10 9 8 7 6 5 4 3 2 1 0																														
ID	A																														
Reset 0x00000000	0 0																														
ID	R/W	Field	Value ID	Value	Description																										
A	W	TASKS_CAPTURE			Capture Timer value to CC[n] register																										
			Trigger	1	Trigger task																										

6.16.5.7 SUBSCRIBE_START

Address offset: 0x080

Subscribe configuration for task START

Bit number	31 30 29 28 27 26 25 24 23 22 21 20 19 18 17 16 15 14 13 12 11 10 9 8 7 6 5 4 3 2 1 0																														
ID	B																								A A A A A A A						
Reset 0x00000000	0 0																														
ID	R/W	Field	Value ID	Value	Description																										
A	RW	CHIDX		[0..255]	DPPI channel that task START will subscribe to																										
B	RW	EN	Disabled	0	Disable subscription																										
			Enabled	1	Enable subscription																										

6.16.5.8 SUBSCRIBE_STOP

Address offset: 0x084

Subscribe configuration for task STOP

Bit number	31 30 29 28 27 26 25 24 23 22 21 20 19 18 17 16 15 14 13 12 11 10 9 8 7 6 5 4 3 2 1 0																														
ID	B																								A A A A A A A						
Reset 0x00000000	0 0																														
ID	R/W	Field	Value ID	Value	Description																										
A	RW	CHIDX		[0..255]	DPPI channel that task STOP will subscribe to																										
B	RW	EN	Disabled	0	Disable subscription																										
			Enabled	1	Enable subscription																										

6.16.5.9 SUBSCRIBE_COUNT

Address offset: 0x088

Subscribe configuration for task **COUNT**

Bit number	31 30 29 28 27 26 25 24 23 22 21 20 19 18 17 16 15 14 13 12 11 10 9 8 7 6 5 4 3 2 1 0																															
ID	B																A A A A A A A A															
Reset 0x00000000	0 0																															
ID	R/W	Field	Value ID	Value	Description																											
A	RW	CHIDX		[0..255]	DPPI channel that task COUNT will subscribe to																											
B	RW	EN	Disabled	0	Disable subscription																											
			Enabled	1	Enable subscription																											

6.16.5.10 SUBSCRIBE_CLEAR

Address offset: 0x08C

Subscribe configuration for task **CLEAR**

Bit number	31 30 29 28 27 26 25 24 23 22 21 20 19 18 17 16 15 14 13 12 11 10 9 8 7 6 5 4 3 2 1 0																															
ID	B																A A A A A A A A															
Reset 0x00000000	0 0																															
ID	R/W	Field	Value ID	Value	Description																											
A	RW	CHIDX		[0..255]	DPPI channel that task CLEAR will subscribe to																											
B	RW	EN	Disabled	0	Disable subscription																											
			Enabled	1	Enable subscription																											

6.16.5.11 SUBSCRIBE_SHUTDOWN (Deprecated)

Address offset: 0x090

Subscribe configuration for task **SHUTDOWN**

This register is deprecated.

Bit number	31 30 29 28 27 26 25 24 23 22 21 20 19 18 17 16 15 14 13 12 11 10 9 8 7 6 5 4 3 2 1 0																															
ID	B																A A A A A A A A															
Reset 0x00000000	0 0																															
ID	R/W	Field	Value ID	Value	Description																											
A	RW	CHIDX		[0..255]	DPPI channel that task SHUTDOWN will subscribe to																											
B	RW	EN	Disabled	0	Disable subscription																											
			Enabled	1	Enable subscription																											

6.16.5.12 SUBSCRIBE_CAPTURE[n] (n=0..5)

Address offset: 0x0C0 + (n × 0x4)

Subscribe configuration for task **CAPTURE[n]**

Bit number	31 30 29 28 27 26 25 24 23 22 21 20 19 18 17 16 15 14 13 12 11 10 9 8 7 6 5 4 3 2 1 0																														
ID	B																								A A A A A A A						
Reset 0x00000000	0 0																														
ID	R/W	Field	Value ID	Value	Description																										
A	RW	CHIDX		[0..255]	DPPI channel that task <code>CAPTURE[n]</code> will subscribe to																										
B	RW	EN	Disabled	0	Disable subscription																										
			Enabled	1	Enable subscription																										

6.16.5.13 EVENTS_COMPARE[n] (n=0..5)

Address offset: $0x140 + (n \times 0x4)$

Compare event on CC[n] match

Bit number	31 30 29 28 27 26 25 24 23 22 21 20 19 18 17 16 15 14 13 12 11 10 9 8 7 6 5 4 3 2 1 0																														
ID																														A	
Reset 0x00000000	0 0																														
ID	R/W	Field	Value ID	Value	Description																										
A	RW	EVENTS_COMPARE			Compare event on CC[n] match																										
			NotGenerated	0	Event not generated																										
			Generated	1	Event generated																										

6.16.5.14 PUBLISH_COMPARE[n] (n=0..5)

Address offset: $0x1C0 + (n \times 0x4)$

Publish configuration for event `COMPARE[n]`

Bit number	31 30 29 28 27 26 25 24 23 22 21 20 19 18 17 16 15 14 13 12 11 10 9 8 7 6 5 4 3 2 1 0																														
ID	B																								A A A A A A A						
Reset 0x00000000	0 0																														
ID	R/W	Field	Value ID	Value	Description																										
A	RW	CHIDX		[0..255]	DPPI channel that event <code>COMPARE[n]</code> will publish to																										
B	RW	EN	Disabled	0	Disable publishing																										
			Enabled	1	Enable publishing																										

6.16.5.15 SHORTS

Address offset: $0x200$

Shortcuts between local events and tasks

Bit number	31 30 29 28 27 26 25 24 23 22 21 20 19 18 17 16 15 14 13 12 11 10 9 8 7 6 5 4 3 2 1 0																														
ID															L K J I H G				F E D C B A												
Reset 0x00000000	0 0																														
ID	R/W	Field	Value ID	Value	Description																										
A-F	RW	COMPARE[i]_CLEAR (i=0..5)			Shortcut between event <code>COMPARE[i]</code> and task <code>CLEAR</code>																										
			Disabled	0	Disable shortcut																										
			Enabled	1	Enable shortcut																										
G-L	RW	COMPARE[i]_STOP (i=0..5)			Shortcut between event <code>COMPARE[i]</code> and task <code>STOP</code>																										
			Disabled	0	Disable shortcut																										
			Enabled	1	Enable shortcut																										

6.16.5.16 INTENSET

Address offset: 0x304

Enable interrupt

Bit number	31 30 29 28 27 26 25 24 23 22 21 20 19 18 17 16 15 14 13 12 11 10 9 8 7 6 5 4 3 2 1 0																														
ID	F E D C B A																														
Reset 0x00000000	0 0																														
ID	R/W	Field	Value ID	Value	Description																										
A-F	RW	COMPARE[i] (i=0..5)			Write '1' to enable interrupt for event COMPARE[i]																										
			Set	1	Enable																										
			Disabled	0	Read: Disabled																										
			Enabled	1	Read: Enabled																										

6.16.5.17 INTENCLR

Address offset: 0x308

Disable interrupt

Bit number	31 30 29 28 27 26 25 24 23 22 21 20 19 18 17 16 15 14 13 12 11 10 9 8 7 6 5 4 3 2 1 0																														
ID	F E D C B A																														
Reset 0x00000000	0 0																														
ID	R/W	Field	Value ID	Value	Description																										
A-F	RW	COMPARE[i] (i=0..5)			Write '1' to disable interrupt for event COMPARE[i]																										
			Clear	1	Disable																										
			Disabled	0	Read: Disabled																										
			Enabled	1	Read: Enabled																										

6.16.5.18 MODE

Address offset: 0x504

Timer mode selection

Bit number	31 30 29 28 27 26 25 24 23 22 21 20 19 18 17 16 15 14 13 12 11 10 9 8 7 6 5 4 3 2 1 0																														
ID	A A																														
Reset 0x00000000	0 0																														
ID	R/W	Field	Value ID	Value	Description																										
A	RW	MODE			Timer mode																										
			Timer	0	Select Timer mode																										
			Counter	1	Select Counter mode																										
					This enumerator is deprecated.																										
			LowPowerCounter	2	Select Low Power Counter mode																										

6.16.5.19 BITMODE

Address offset: 0x508

Configure the number of bits used by the TIMER

Bit number	31	30	29	28	27	26	25	24	23	22	21	20	19	18	17	16	15	14	13	12	11	10	9	8	7	6	5	4	3	2	1	0	
ID																																A	A
Reset 0x00000000	0 0																																
ID	R/W	Field	Value ID	Value	Description																												
A	RW	BITMODE			Timer bit width																												
			16Bit	0	16 bit timer bit width																												
			08Bit	1	8 bit timer bit width																												
			24Bit	2	24 bit timer bit width																												
			32Bit	3	32 bit timer bit width																												

6.16.5.20 PRESCALER

Address offset: 0x510

Timer prescaler register

Bit number	31	30	29	28	27	26	25	24	23	22	21	20	19	18	17	16	15	14	13	12	11	10	9	8	7	6	5	4	3	2	1	0			
ID																																A	A	A	A
Reset 0x00000004	0 1 0 0																																		
ID	R/W	Field	Value ID	Value	Description																														
A	RW	PRESCALER		[0..9]	Prescaler value																														

6.16.5.21 ONESHOTEN[n] (n=0..5)

Address offset: 0x514 + (n × 0x4)

Enable one-shot operation for Capture/Compare channel n

Bit number	31	30	29	28	27	26	25	24	23	22	21	20	19	18	17	16	15	14	13	12	11	10	9	8	7	6	5	4	3	2	1	0
ID																																A
Reset 0x00000000	0 0																															
ID	R/W	Field	Value ID	Value	Description																											
A	RW	ONESHOTEN			Enable one-shot operation																											
			Disable	0	Configures the corresponding compare-channel for one-shot operation Disable one-shot operation																											
			Enable	1	Compare event is generated every time the Counter matches CC[n] Enable one-shot operation Compare event is generated the first time the Counter matches CC[n] after CC[n] has been written																											

6.16.5.22 CC[n] (n=0..5)

Address offset: 0x540 + (n × 0x4)

Capture/Compare register n

Bit number	31	30	29	28	27	26	25	24	23	22	21	20	19	18	17	16	15	14	13	12	11	10	9	8	7	6	5	4	3	2	1	0
ID	A	A	A	A	A	A	A	A	A	A	A	A	A	A	A	A	A	A	A	A	A	A	A	A	A	A	A	A	A	A	A	A
Reset 0x00000000	0 0																															
ID	R/W	Field	Value ID	Value	Description																											
A	RW	CC			Capture/Compare value																											
					Only the number of bits indicated by BITMODE will be used by the TIMER.																											

6.17 TWIM – I²C compatible two-wire interface master with EasyDMA

TWI master with EasyDMA (TWIM) is a two-wire half-duplex master which can communicate with multiple slave devices connected to the same bus.

Listed here are the main features for TWIM:

- I²C compatible
- Supported baud rates: 100, 250, 400 kbps
- Support for clock stretching (non I²C compliant)
- EasyDMA

The two-wire interface can communicate with a bi-directional wired-AND bus with two lines (SCL, SDA). The protocol makes it possible to interconnect up to 127 individually addressable devices. TWIM is not compatible with CBUS.

The GPIOs used for each two-wire interface line can be chosen from any GPIO on the device and are independently configurable. This enables great flexibility in device pinout and efficient use of board space and signal routing.

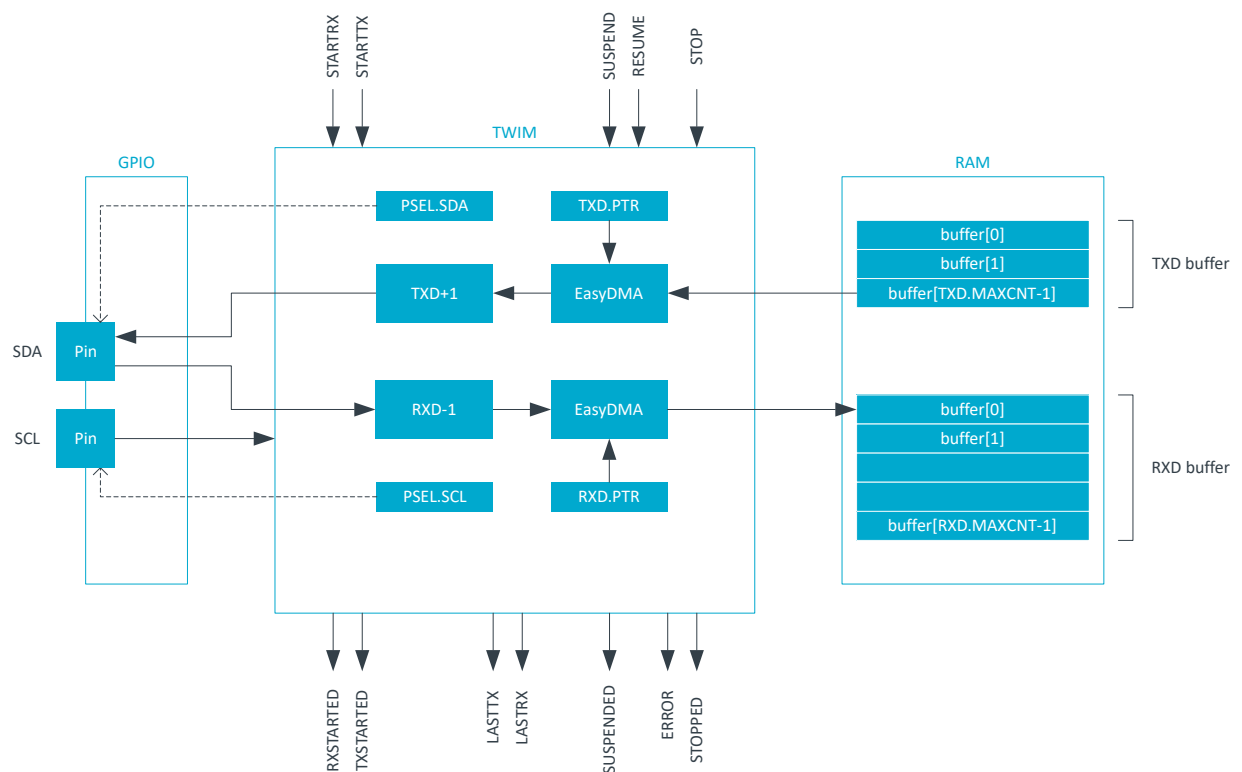

Figure 94: TWI master with EasyDMA

A typical TWI setup consists of one master and one or more slaves. For an example, see the following figure. This TWIM is only able to operate as a single master on the TWI bus. Multi-master bus configuration is not supported.

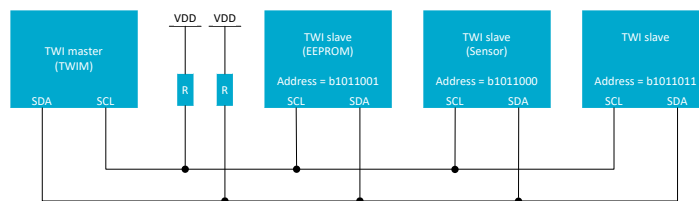

Figure 95: A typical TWI setup comprising one master and three slaves

This TWI master supports clock stretching performed by the slaves. The SCK pulse following a stretched clock cycle may be shorter than specified by the I2C specification.

The TWI master is started by triggering the STARTTX or STARTRX tasks and stopped by triggering the STOP task. The TWI master will generate a STOPPED event when it has stopped following a STOP task.

After the TWI master is started, the STARTTX or STARTRX tasks should not be triggered again until the TWI master has issued a LASTRX, LASTTX, or STOPPED event.

The TWI master can be suspended using the SUSPEND task, this can be used when using the TWI master in a low priority interrupt context. When the TWIM enters suspend state, will automatically issue a SUSPENDED event while performing a continuous clock stretching until it is instructed to resume operation via a RESUME task. The TWI master cannot be stopped while it is suspended, thus the STOP task must be issued after the TWI master has been resumed.

Note: Any ongoing byte transfer will be allowed to complete before the suspend is enforced. A SUSPEND task has no effect unless the TWI master is actively involved in a transfer.

If a NACK is clocked in from the slave, the TWI master will generate an ERROR event.

6.17.1 Shared resources

The TWI master shares registers and other resources with other peripherals that have the same ID as the TWI master. Therefore, you must disable all peripherals that have the same ID as the TWI master before the TWI master can be configured and used.

Disabling a peripheral that has the same ID as the TWI master will not reset any of the registers that are shared with the TWI master. It is therefore important to configure all relevant registers explicitly to secure that the TWI master operates correctly.

The Instantiation table in [Instantiation](#) on page 27 shows which peripherals have the same ID as the TWI.

6.17.2 EasyDMA

The TWIM implements EasyDMA for accessing RAM without CPU involvement.

The TWIM peripheral implements the EasyDMA channels found in the following table.

Channel	Type	Register Cluster
TXD	READER	TXD
RXD	WRITER	RXD

Table 44: TWIM EasyDMA Channels

For detailed information regarding the use of EasyDMA, see [EasyDMA](#) on page 48.

The .PTR and .MAXCNT registers are double-buffered. They can be updated and prepared for the next RX/TX transmission immediately after having received the RXSTARTED/TXSTARTED event.

The STOPPED event indicates that EasyDMA has finished accessing the buffer in RAM.

6.17.3 Master write sequence

A TWI master write sequence is started by triggering the STARTTX task. After the STARTTX task has been triggered, the TWI master will generate a start condition on the TWI bus, followed by clocking out the address and the READ/WRITE bit set to 0 (WRITE=0, READ=1).

The address must match the address of the slave device that the master wants to write to. The READ/WRITE bit is followed by an ACK/NACK bit (ACK=0 or NACK=1) generated by the slave.

After receiving the ACK bit, the TWI master will clock out the data bytes found in the transmit buffer located in RAM at the address specified in the TXD.PTR register. Each byte clocked out from the master will be followed by an ACK/NACK bit clocked in from the slave.

A typical TWI master write sequence is shown in the following figure. Occurrence 2 in the figure illustrates clock stretching performed by the TWI master following a SUSPEND task.

A SUSPENDED event indicates that the SUSPEND task has taken effect. This event can be used to synchronize the software.

The TWI master will generate a LASTTX event when it starts to transmit the last byte, this is shown in the following figure.

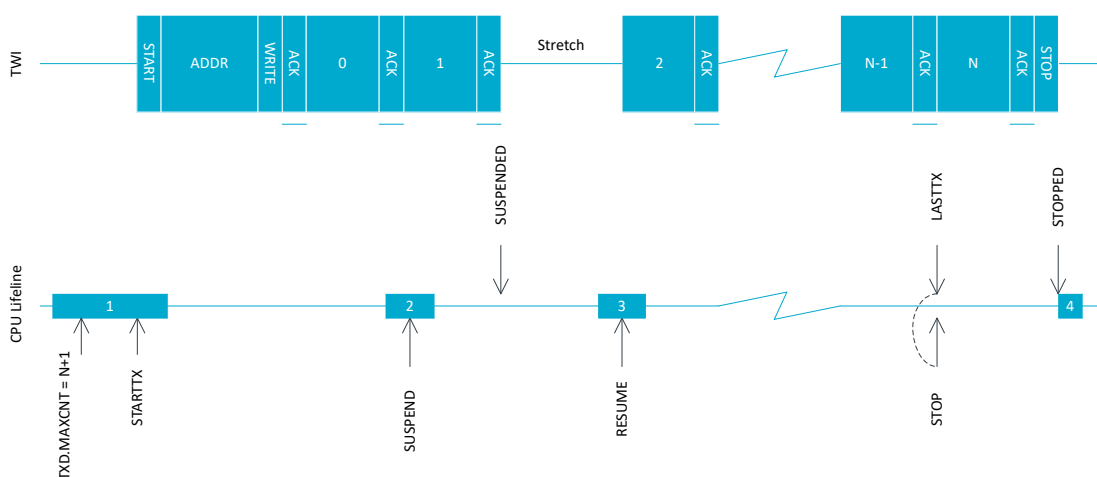

Figure 96: TWI master writing data to a slave

The TWI master is stopped by triggering the STOP task. This task should be triggered during the transmission of the last byte to secure that the TWI master will stop as fast as possible after sending the last byte. The shortcut between LASTTX and STOP can alternatively be used to accomplish this.

Note: The TWI master does not stop by itself when the entire RAM buffer has been sent, or when an error occurs. The STOP task must be issued, using a local or PPI shortcut, or in software as part of the error handler.

6.17.4 Master read sequence

A TWI master read sequence is started by triggering the STARTRX task. After the STARTRX task has been triggered, the TWI master will generate a start condition on the TWI bus, followed by clocking out the address and the READ/WRITE bit set to 1 (WRITE = 0, READ = 1). The address must match the address of the slave device that the master wants to read from. The READ/WRITE bit is followed by an ACK/NACK bit (ACK=0 or NACK = 1) generated by the slave.

After sending the ACK bit, the TWI slave will send data to the master using the clock generated by the master.

Data received will be stored in RAM at the address specified in the RXD.PTR register. The TWI master will generate an ACK after all but the last byte have been received from the slave. The TWI master will generate a NACK after the last byte received to indicate that the read sequence shall stop.

A typical TWI master read sequence is illustrated in [The TWI master reading data from a slave](#) on page 358. Occurrence 2 in the figure illustrates clock stretching performed by the TWI master following a SUSPEND task.

A SUSPENDED event indicates that the SUSPEND task has taken effect. This event can be used to synchronize the software.

The TWI master will generate a LASTRX event when it is ready to receive the last byte, as shown in [The TWI master reading data from a slave](#) on page 358. If RXD.MAXCNT > 1, the LASTRX event is generated after sending the ACK of the previously received byte. If RXD.MAXCNT = 1, the LASTRX event is generated after receiving the ACK following the address and READ bit.

The TWI master is stopped by triggering the STOP task. This task must be triggered before the NACK bit is supposed to be transmitted. The STOP task can be triggered at any time during the reception of the last byte. It is recommended to use the shortcut between LASTRX and STOP to accomplish this.

The TWI master does not stop by itself when the RAM buffer is full, or when an error occurs. The STOP task must be issued, using a local or PPI shortcut, or in software as part of the error handler.

The TWI master cannot be stopped while suspended, so the STOP task must be issued after the TWI master has been resumed.

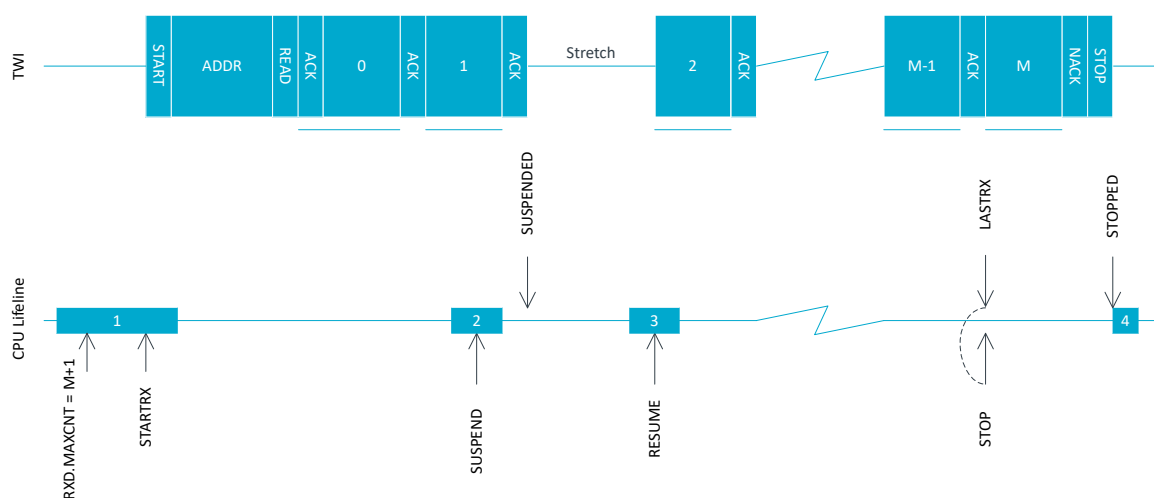

Figure 97: The TWI master reading data from a slave

6.17.5 Master repeated start sequence

A typical repeated start sequence is one in which the TWI master writes two bytes to the slave followed by reading four bytes from the slave. This example uses shortcuts to perform the simplest type of repeated start sequence, i.e. one write followed by one read. The same approach can be used to perform a repeated start sequence where the sequence is read followed by write.

The following figure shows an example of a repeated start sequence where the TWI master writes two bytes followed by reading four bytes from the slave.

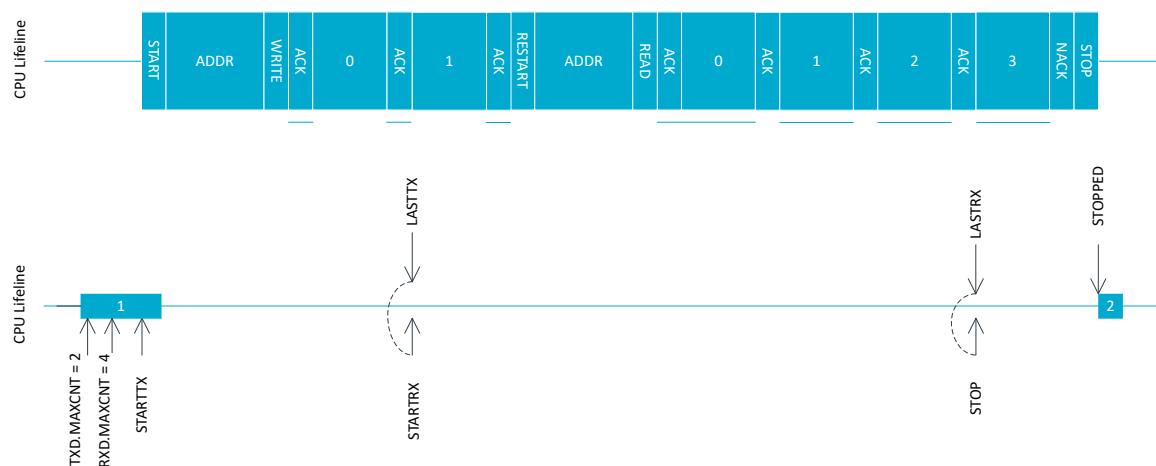

Figure 98: Master repeated start sequence

If a more complex repeated start sequence is needed, and the TWI firmware driver is serviced in a low priority interrupt, it may be necessary to use the SUSPEND task and SUSPENDED event to guarantee that the correct tasks are generated at the correct time. A double repeated start sequence using the SUSPEND task to secure safe operation in low priority interrupts is shown in the following figure.

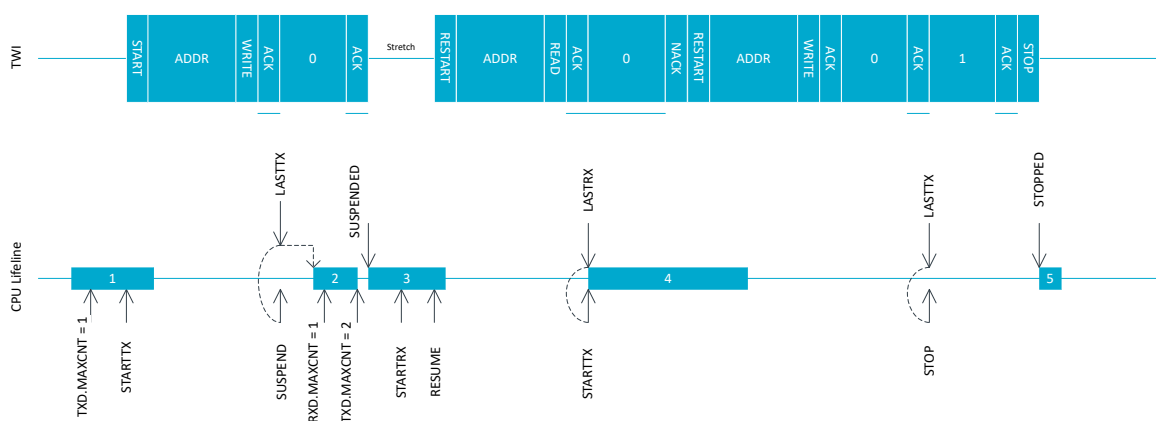

Figure 99: Double repeated start sequence

6.17.6 Low power

When putting the system in low power and the peripheral is not needed, lowest possible power consumption is achieved by stopping, and then disabling the peripheral.

When the STOP task is sent, the software shall wait until the STOPPED event is received as a response before disabling the peripheral through the ENABLE register. If the peripheral is already stopped, the STOP task is not required.

6.17.7 Master mode pin configuration

The SCL and SDA signals associated with the TWI master are mapped to physical pins according to the configuration specified in the PSEL.SCL and PSEL.SDA registers respectively.

The PSEL.SCL and PSEL.SDA registers and their configurations are only used as long as the TWI master is enabled, and retained only as long as the device is in ON mode. When the peripheral is disabled, the pins will behave as regular GPIOs, and use the configuration in their respective OUT bit field and PIN_CNF[n] register. PSEL.SCL, PSEL.SDA must only be configured when the TWI master is disabled.

To secure correct signal levels on the pins used by the TWI master when the system is in OFF mode, and when the TWI master is disabled, these pins must be configured in the GPIO peripheral as described in the following table.

Only one peripheral can be assigned to drive a particular GPIO pin at a time. Failing to do so may result in unpredictable behavior.

TWI master signal	TWI master pin	Direction	Output value	Drive strength
SCL	As specified in PSEL.SCL	Input	Not applicable	S0D1
SDA	As specified in PSEL.SDA	Input	Not applicable	S0D1

Table 45: GPIO configuration before enabling peripheral

6.17.8 Registers

Instances

Instance	Base address	TrustZone			Split access	Description
		Map	Att	DMA		
TWIM0 : S	0x50008000	US	NS	SA	No	Two-wire interface master 0
TWIM0 : NS	0x40008000					
TWIM1 : S	0x50009000	US	NS	SA	No	Two-wire interface master 1
TWIM1 : NS	0x40009000					
TWIM2 : S	0x5000A000	US	NS	SA	No	Two-wire interface master 2
TWIM2 : NS	0x4000A000					
TWIM3 : S	0x5000B000	US	NS	SA	No	Two-wire interface master 3
TWIM3 : NS	0x4000B000					

Register overview

Register	Offset	TZ	Description
TASKS_STARTRX	0x000		Start TWI receive sequence
TASKS_STARTTX	0x008		Start TWI transmit sequence
TASKS_STOP	0x014		Stop TWI transaction. Must be issued while the TWI master is not suspended.
TASKS_SUSPEND	0x01C		Suspend TWI transaction
TASKS_RESUME	0x020		Resume TWI transaction
SUBSCRIBE_STARTRX	0x080		Subscribe configuration for task STARTRX
SUBSCRIBE_STARTTX	0x088		Subscribe configuration for task STARTTX
SUBSCRIBE_STOP	0x094		Subscribe configuration for task STOP
SUBSCRIBE_SUSPEND	0x09C		Subscribe configuration for task SUSPEND
SUBSCRIBE_RESUME	0x0A0		Subscribe configuration for task RESUME
EVENTS_STOPPED	0x104		TWI stopped
EVENTS_ERROR	0x124		TWI error
EVENTS_SUSPENDED	0x148		SUSPEND task has been issued, TWI traffic is now suspended.
EVENTS_RXSTARTED	0x14C		Receive sequence started
EVENTS_TXSTARTED	0x150		Transmit sequence started
EVENTS_LASTRX	0x15C		Byte boundary, starting to receive the last byte
EVENTS_LASTTX	0x160		Byte boundary, starting to transmit the last byte
PUBLISH_STOPPED	0x184		Publish configuration for event STOPPED
PUBLISH_ERROR	0x1A4		Publish configuration for event ERROR
PUBLISH_SUSPENDED	0x1C8		Publish configuration for event SUSPENDED
PUBLISH_RXSTARTED	0x1CC		Publish configuration for event RXSTARTED

Register	Offset	TZ	Description
PUBLISH_TXSTARTED	0x1D0		Publish configuration for event TXSTARTED
PUBLISH_LASTRX	0x1DC		Publish configuration for event LASTRX
PUBLISH_LASTTX	0x1E0		Publish configuration for event LASTTX
SHORTS	0x200		Shortcuts between local events and tasks
INTEN	0x300		Enable or disable interrupt
INTENSET	0x304		Enable interrupt
INTENCLR	0x308		Disable interrupt
ERRORSRC	0x4C4		Error source
ENABLE	0x500		Enable TWIM
PSEL.SCL	0x508		Pin select for SCL signal
PSEL.SDA	0x50C		Pin select for SDA signal
FREQUENCY	0x524		TWI frequency. Accuracy depends on the HFCLK source selected.
RXD.PTR	0x534		Data pointer
RXD.MAXCNT	0x538		Maximum number of bytes in receive buffer
RXD.AMOUNT	0x53C		Number of bytes transferred in the last transaction
RXD.LIST	0x540		EasyDMA list type
TXD.PTR	0x544		Data pointer
TXD.MAXCNT	0x548		Maximum number of bytes in transmit buffer
TXD.AMOUNT	0x54C		Number of bytes transferred in the last transaction
TXD.LIST	0x550		EasyDMA list type
ADDRESS	0x588		Address used in the TWI transfer

6.17.8.1 TASKS_STARTRX

Address offset: 0x000

Start TWI receive sequence

Bit number	31	30	29	28	27	26	25	24	23	22	21	20	19	18	17	16	15	14	13	12	11	10	9	8	7	6	5	4	3	2	1	0
ID																																A
Reset 0x00000000	0 0																															
ID	R/W	Field	Value ID	Value	Description																											
A	W	TASKS_STARTRX			Start TWI receive sequence																											
			Trigger	1	Trigger task																											

6.17.8.2 TASKS_STARTTX

Address offset: 0x008

Start TWI transmit sequence

Bit number	31	30	29	28	27	26	25	24	23	22	21	20	19	18	17	16	15	14	13	12	11	10	9	8	7	6	5	4	3	2	1	0
ID																																A
Reset 0x00000000	0 0																															
ID	R/W	Field	Value ID	Value	Description																											
A	W	TASKS_STARTTX			Start TWI transmit sequence																											
			Trigger	1	Trigger task																											

6.17.8.3 TASKS_STOP

Address offset: 0x014

Stop TWI transaction. Must be issued while the TWI master is not suspended.

Bit number	31	30	29	28	27	26	25	24	23	22	21	20	19	18	17	16	15	14	13	12	11	10	9	8	7	6	5	4	3	2	1	0
ID																																A
Reset 0x00000000	0 0																															
ID	R/W	Field	Value ID	Value	Description																											
A	W	TASKS_STOP			Stop TWI transaction. Must be issued while the TWI master is not suspended.																											
			Trigger	1	Trigger task																											

6.17.8.4 TASKS_SUSPEND

Address offset: 0x01C

Suspend TWI transaction

Bit number	31	30	29	28	27	26	25	24	23	22	21	20	19	18	17	16	15	14	13	12	11	10	9	8	7	6	5	4	3	2	1	0
ID																																A
Reset 0x00000000	0 0																															
ID	R/W	Field	Value ID	Value	Description																											
A	W	TASKS_SUSPEND			Suspend TWI transaction																											
			Trigger	1	Trigger task																											

6.17.8.5 TASKS_RESUME

Address offset: 0x020

Resume TWI transaction

Bit number	31	30	29	28	27	26	25	24	23	22	21	20	19	18	17	16	15	14	13	12	11	10	9	8	7	6	5	4	3	2	1	0
ID																																A
Reset 0x00000000	0 0																															
ID	R/W	Field	Value ID	Value	Description																											
A	W	TASKS_RESUME			Resume TWI transaction																											
			Trigger	1	Trigger task																											

6.17.8.6 SUBSCRIBE_STARTRX

Address offset: 0x080

Subscribe configuration for task **STARTRX**

Bit number	31	30	29	28	27	26	25	24	23	22	21	20	19	18	17	16	15	14	13	12	11	10	9	8	7	6	5	4	3	2	1	0													
ID																									B													A	A	A	A	A	A	A	A
Reset 0x00000000	0 0																																												
ID	R/W	Field	Value ID	Value	Description																																								
A	RW	CHIDX		[0..255]	DPPI channel that task STARTRX will subscribe to																																								
B	RW	EN	Disabled	0	Disable subscription																																								
			Enabled	1	Enable subscription																																								

6.17.8.7 SUBSCRIBE_STARTTX

Address offset: 0x088

Subscribe configuration for task **STARTTX**

Bit number	31 30 29 28 27 26 25 24 23 22 21 20 19 18 17 16 15 14 13 12 11 10 9 8 7 6 5 4 3 2 1 0																														
ID	B																								A A A A A A A						
Reset	0x00000000																														
	0 0																														
ID	R/W	Field	Value ID	Value	Description																										
A	RW	CHIDX		[0..255]	DPPI channel that task STARTTX will subscribe to																										
B	RW	EN	Disabled	0	Disable subscription																										
			Enabled	1	Enable subscription																										

6.17.8.8 SUBSCRIBE_STOP

Address offset: 0x094

Subscribe configuration for task **STOP**

Bit number	31 30 29 28 27 26 25 24 23 22 21 20 19 18 17 16 15 14 13 12 11 10 9 8 7 6 5 4 3 2 1 0																														
ID	B																								A A A A A A A						
Reset	0x00000000																														
	0 0																														
ID	R/W	Field	Value ID	Value	Description																										
A	RW	CHIDX		[0..255]	DPPI channel that task STOP will subscribe to																										
B	RW	EN	Disabled	0	Disable subscription																										
			Enabled	1	Enable subscription																										

6.17.8.9 SUBSCRIBE_SUSPEND

Address offset: 0x09C

Subscribe configuration for task **SUSPEND**

Bit number	31 30 29 28 27 26 25 24 23 22 21 20 19 18 17 16 15 14 13 12 11 10 9 8 7 6 5 4 3 2 1 0																														
ID	B																								A A A A A A A						
Reset	0x00000000																														
	0 0																														
ID	R/W	Field	Value ID	Value	Description																										
A	RW	CHIDX		[0..255]	DPPI channel that task SUSPEND will subscribe to																										
B	RW	EN	Disabled	0	Disable subscription																										
			Enabled	1	Enable subscription																										

6.17.8.10 SUBSCRIBE_RESUME

Address offset: 0x0A0

Subscribe configuration for task **RESUME**

Bit number	31 30 29 28 27 26 25 24 23 22 21 20 19 18 17 16 15 14 13 12 11 10 9 8 7 6 5 4 3 2 1 0																														
ID	B																								A A A A A A A						
Reset	0x00000000																														
	0 0																														
ID	R/W	Field	Value ID	Value	Description																										
A	RW	CHIDX		[0..255]	DPPI channel that task RESUME will subscribe to																										
B	RW	EN	Disabled	0	Disable subscription																										
			Enabled	1	Enable subscription																										

6.17.8.11 EVENTS_STOPPED

Address offset: 0x104

TWI stopped

Bit number	31 30 29 28 27 26 25 24 23 22 21 20 19 18 17 16 15 14 13 12 11 10 9 8 7 6 5 4 3 2 1 0																														
ID	A																														
Reset 0x00000000	0 0																														
ID	R/W	Field	Value ID	Value	Description																										
A	RW	EVENTS_STOPPED			TWI stopped																										
			NotGenerated	0	Event not generated																										
			Generated	1	Event generated																										

6.17.8.12 EVENTS_ERROR

Address offset: 0x124

TWI error

Bit number	31 30 29 28 27 26 25 24 23 22 21 20 19 18 17 16 15 14 13 12 11 10 9 8 7 6 5 4 3 2 1 0																														
ID	A																														
Reset 0x00000000	0 0																														
ID	R/W	Field	Value ID	Value	Description																										
A	RW	EVENTS_ERROR			TWI error																										
			NotGenerated	0	Event not generated																										
			Generated	1	Event generated																										

6.17.8.13 EVENTS_SUSPENDED

Address offset: 0x148

SUSPEND task has been issued, TWI traffic is now suspended.

Bit number	31 30 29 28 27 26 25 24 23 22 21 20 19 18 17 16 15 14 13 12 11 10 9 8 7 6 5 4 3 2 1 0																														
ID	A																														
Reset 0x00000000	0 0																														
ID	R/W	Field	Value ID	Value	Description																										
A	RW	EVENTS_SUSPENDED			SUSPEND task has been issued, TWI traffic is now suspended.																										
			NotGenerated	0	Event not generated																										
			Generated	1	Event generated																										

6.17.8.14 EVENTS_RXSTARTED

Address offset: 0x14C

Receive sequence started

Bit number	31 30 29 28 27 26 25 24 23 22 21 20 19 18 17 16 15 14 13 12 11 10 9 8 7 6 5 4 3 2 1 0																														
ID	A																														
Reset 0x00000000	0 0																														
ID	R/W	Field	Value ID	Value	Description																										
A	RW	EVENTS_RXSTARTED			Receive sequence started																										
			NotGenerated	0	Event not generated																										
			Generated	1	Event generated																										

6.17.8.15 EVENTS_TXSTARTED

Address offset: 0x150

Transmit sequence started

Bit number	31 30 29 28 27 26 25 24 23 22 21 20 19 18 17 16 15 14 13 12 11 10 9 8 7 6 5 4 3 2 1 0																														
ID	A																														
Reset 0x00000000	0 0																														
ID	R/W	Field	Value ID	Value	Description																										
A	RW	EVENTS_TXSTARTED			Transmit sequence started																										
			NotGenerated	0	Event not generated																										
			Generated	1	Event generated																										

6.17.8.16 EVENTS_LASTRX

Address offset: 0x15C

Byte boundary, starting to receive the last byte

Bit number	31 30 29 28 27 26 25 24 23 22 21 20 19 18 17 16 15 14 13 12 11 10 9 8 7 6 5 4 3 2 1 0																														
ID	A																														
Reset 0x00000000	0 0																														
ID	R/W	Field	Value ID	Value	Description																										
A	RW	EVENTS_LASTRX			Byte boundary, starting to receive the last byte																										
			NotGenerated	0	Event not generated																										
			Generated	1	Event generated																										

6.17.8.17 EVENTS_LASTTX

Address offset: 0x160

Byte boundary, starting to transmit the last byte

Bit number	31 30 29 28 27 26 25 24 23 22 21 20 19 18 17 16 15 14 13 12 11 10 9 8 7 6 5 4 3 2 1 0																														
ID	A																														
Reset 0x00000000	0 0																														
ID	R/W	Field	Value ID	Value	Description																										
A	RW	EVENTS_LASTTX			Byte boundary, starting to transmit the last byte																										
			NotGenerated	0	Event not generated																										
			Generated	1	Event generated																										

6.17.8.18 PUBLISH_STOPPED

Address offset: 0x184

Publish configuration for event STOPPED

Bit number	31 30 29 28 27 26 25 24 23 22 21 20 19 18 17 16 15 14 13 12 11 10 9 8 7 6 5 4 3 2 1 0																														
ID	B																								A A A A A A A						
Reset 0x00000000	0 0																														
ID	R/W	Field	Value ID	Value	Description																										
A	RW	CHIDX		[0..255]	DPPI channel that event STOPPED will publish to																										
B	RW	EN	Disabled	0	Disable publishing																										
			Enabled	1	Enable publishing																										

6.17.8.19 PUBLISH_ERROR

Address offset: 0x1A4

Publish configuration for event **ERROR**

Bit number	31 30 29 28 27 26 25 24 23 22 21 20 19 18 17 16 15 14 13 12 11 10 9 8 7 6 5 4 3 2 1 0																														
ID	B																								A A A A A A A						
Reset 0x00000000	0 0																														
ID	R/W	Field	Value ID	Value	Description																										
A	RW	CHIDX		[0..255]	DPPI channel that event ERROR will publish to																										
B	RW	EN	Disabled	0	Disable publishing																										
			Enabled	1	Enable publishing																										

6.17.8.20 PUBLISH_SUSPENDED

Address offset: 0x1C8

Publish configuration for event **SUSPENDED**

Bit number	31 30 29 28 27 26 25 24 23 22 21 20 19 18 17 16 15 14 13 12 11 10 9 8 7 6 5 4 3 2 1 0																														
ID	B																								A A A A A A A						
Reset 0x00000000	0 0																														
ID	R/W	Field	Value ID	Value	Description																										
A	RW	CHIDX		[0..255]	DPPI channel that event SUSPENDED will publish to																										
B	RW	EN	Disabled	0	Disable publishing																										
			Enabled	1	Enable publishing																										

6.17.8.21 PUBLISH_RXSTARTED

Address offset: 0x1CC

Publish configuration for event **RXSTARTED**

Bit number	31 30 29 28 27 26 25 24 23 22 21 20 19 18 17 16 15 14 13 12 11 10 9 8 7 6 5 4 3 2 1 0																														
ID	B																								A A A A A A A						
Reset 0x00000000	0 0																														
ID	R/W	Field	Value ID	Value	Description																										
A	RW	CHIDX		[0..255]	DPPI channel that event RXSTARTED will publish to																										
B	RW	EN	Disabled	0	Disable publishing																										
			Enabled	1	Enable publishing																										

6.17.8.22 PUBLISH_TXSTARTED

Address offset: 0x1D0

Publish configuration for event **TXSTARTED**

Bit number	31 30 29 28 27 26 25 24 23 22 21 20 19 18 17 16 15 14 13 12 11 10 9 8 7 6 5 4 3 2 1 0																														
ID	B																								A A A A A A A						
Reset 0x00000000	0 0																														
ID	R/W	Field	Value ID	Value	Description																										
A	RW	CHIDX		[0..255]	DPPI channel that event TXSTARTED will publish to																										
B	RW	EN	Disabled	0	Disable publishing																										
			Enabled	1	Enable publishing																										

6.17.8.23 PUBLISH_LASTRX

Address offset: 0x1DC

Publish configuration for event **LASTRX**

Bit number	31 30 29 28 27 26 25 24 23 22 21 20 19 18 17 16 15 14 13 12 11 10 9 8 7 6 5 4 3 2 1 0																														
ID	B																								A A A A A A A						
Reset 0x00000000	0 0																														
ID	R/W	Field	Value ID	Value	Description																										
A	RW	CHIDX		[0..255]	DPPI channel that event LASTRX will publish to																										
B	RW	EN	Disabled	0	Disable publishing																										
			Enabled	1	Enable publishing																										

6.17.8.24 PUBLISH_LASTTX

Address offset: 0x1E0

Publish configuration for event **LASTTX**

Bit number	31 30 29 28 27 26 25 24 23 22 21 20 19 18 17 16 15 14 13 12 11 10 9 8 7 6 5 4 3 2 1 0																														
ID	B																								A A A A A A A						
Reset 0x00000000	0 0																														
ID	R/W	Field	Value ID	Value	Description																										
A	RW	CHIDX		[0..255]	DPPI channel that event LASTTX will publish to																										
B	RW	EN	Disabled	0	Disable publishing																										
			Enabled	1	Enable publishing																										

6.17.8.25 SHORTS

Address offset: 0x200

Shortcuts between local events and tasks

Bit number		31 30 29 28 27 26 25 24 23 22 21 20 19 18 17 16 15 14 13 12 11 10 9 8 7 6 5 4 3 2 1 0																												
ID		F D C B A																												
Reset 0x00000000		0 0																												
ID	R/W	Field	Value ID	Value	Description																									
A	RW	LASTTX_STARTRX			Shortcut between event LASTTX and task STARTRX																									
			Disabled	0	Disable shortcut																									
			Enabled	1	Enable shortcut																									
B	RW	LASTTX_SUSPEND			Shortcut between event LASTTX and task SUSPEND																									
			Disabled	0	Disable shortcut																									
			Enabled	1	Enable shortcut																									
C	RW	LASTTX_STOP			Shortcut between event LASTTX and task STOP																									
			Disabled	0	Disable shortcut																									
			Enabled	1	Enable shortcut																									
D	RW	LASTRX_STARTTX			Shortcut between event LASTRX and task STARTTX																									
			Disabled	0	Disable shortcut																									
			Enabled	1	Enable shortcut																									
F	RW	LASTRX_STOP			Shortcut between event LASTRX and task STOP																									
			Disabled	0	Disable shortcut																									
			Enabled	1	Enable shortcut																									

6.17.8.26 INTEN

Address offset: 0x300

Enable or disable interrupt

Bit number		31 30 29 28 27 26 25 24 23 22 21 20 19 18 17 16 15 14 13 12 11 10 9 8 7 6 5 4 3 2 1 0																												
ID		J I H G F D A																												
Reset 0x00000000		0 0																												
ID	R/W	Field	Value ID	Value	Description																									
A	RW	STOPPED			Enable or disable interrupt for event STOPPED																									
			Disabled	0	Disable																									
			Enabled	1	Enable																									
D	RW	ERROR			Enable or disable interrupt for event ERROR																									
			Disabled	0	Disable																									
			Enabled	1	Enable																									
F	RW	SUSPENDED			Enable or disable interrupt for event SUSPENDED																									
			Disabled	0	Disable																									
			Enabled	1	Enable																									
G	RW	RXSTARTED			Enable or disable interrupt for event RXSTARTED																									
			Disabled	0	Disable																									
			Enabled	1	Enable																									
H	RW	TXSTARTED			Enable or disable interrupt for event TXSTARTED																									
			Disabled	0	Disable																									
			Enabled	1	Enable																									
I	RW	LASTRX			Enable or disable interrupt for event LASTRX																									
			Disabled	0	Disable																									
			Enabled	1	Enable																									
J	RW	LASTTX			Enable or disable interrupt for event LASTTX																									
			Disabled	0	Disable																									
			Enabled	1	Enable																									

6.17.8.27 INTENSET

Address offset: 0x304

Enable interrupt

Bit number	31 30 29 28 27 26 25 24 23 22 21 20 19 18 17 16 15 14 13 12 11 10 9 8 7 6 5 4 3 2 1 0																																				
ID											J	I	H G F													D											A
Reset 0x00000000	0 0																																				
ID	R/W	Field	Value ID	Value	Description																																
A	RW	STOPPED			Write '1' to enable interrupt for event STOPPED																																
			Set	1	Enable																																
			Disabled	0	Read: Disabled																																
			Enabled	1	Read: Enabled																																
D	RW	ERROR			Write '1' to enable interrupt for event ERROR																																
			Set	1	Enable																																
			Disabled	0	Read: Disabled																																
			Enabled	1	Read: Enabled																																
F	RW	SUSPENDED			Write '1' to enable interrupt for event SUSPENDED																																
			Set	1	Enable																																
			Disabled	0	Read: Disabled																																
			Enabled	1	Read: Enabled																																
G	RW	RXSTARTED			Write '1' to enable interrupt for event RXSTARTED																																
			Set	1	Enable																																
			Disabled	0	Read: Disabled																																
			Enabled	1	Read: Enabled																																
H	RW	TXSTARTED			Write '1' to enable interrupt for event TXSTARTED																																
			Set	1	Enable																																
			Disabled	0	Read: Disabled																																
			Enabled	1	Read: Enabled																																
I	RW	LASTRX			Write '1' to enable interrupt for event LASTRX																																
			Set	1	Enable																																
			Disabled	0	Read: Disabled																																
			Enabled	1	Read: Enabled																																
J	RW	LASTTX			Write '1' to enable interrupt for event LASTTX																																
			Set	1	Enable																																
			Disabled	0	Read: Disabled																																
			Enabled	1	Read: Enabled																																

6.17.8.28 INTENCLR

Address offset: 0x308

Disable interrupt

Bit number	31 30 29 28 27 26 25 24 23 22 21 20 19 18 17 16 15 14 13 12 11 10 9 8 7 6 5 4 3 2 1 0																																				
ID											J	I	H G F													D											A
Reset 0x00000000	0 0																																				
ID	R/W	Field	Value ID	Value	Description																																
A	RW	STOPPED			Write '1' to disable interrupt for event STOPPED																																
			Clear	1	Disable																																
			Disabled	0	Read: Disabled																																
			Enabled	1	Read: Enabled																																
D	RW	ERROR			Write '1' to disable interrupt for event ERROR																																
			Clear	1	Disable																																
			Disabled	0	Read: Disabled																																
			Enabled	1	Read: Enabled																																
F	RW	SUSPENDED			Write '1' to disable interrupt for event SUSPENDED																																
			Clear	1	Disable																																
			Disabled	0	Read: Disabled																																
			Enabled	1	Read: Enabled																																

Bit number		31 30 29 28 27 26 25 24 23 22 21 20 19 18 17 16 15 14 13 12 11 10 9 8 7 6 5 4 3 2 1 0																														
ID		J I H G F										D										A										
Reset 0x00000000		0 0																														
ID	R/W	Field	Value ID	Value	Description																											
			Clear	1	Disable																											
			Disabled	0	Read: Disabled																											
			Enabled	1	Read: Enabled																											
G	RW	RXSTARTED			Write '1' to disable interrupt for event RXSTARTED																											
			Clear	1	Disable																											
			Disabled	0	Read: Disabled																											
			Enabled	1	Read: Enabled																											
H	RW	TXSTARTED			Write '1' to disable interrupt for event TXSTARTED																											
			Clear	1	Disable																											
			Disabled	0	Read: Disabled																											
			Enabled	1	Read: Enabled																											
I	RW	LASTRX			Write '1' to disable interrupt for event LASTRX																											
			Clear	1	Disable																											
			Disabled	0	Read: Disabled																											
			Enabled	1	Read: Enabled																											
J	RW	LASTTX			Write '1' to disable interrupt for event LASTTX																											
			Clear	1	Disable																											
			Disabled	0	Read: Disabled																											
			Enabled	1	Read: Enabled																											

6.17.8.29 ERRORSRC

Address offset: 0x4C4

Error source

Bit number		31 30 29 28 27 26 25 24 23 22 21 20 19 18 17 16 15 14 13 12 11 10 9 8 7 6 5 4 3 2 1 0																														
ID																						C B A										
Reset 0x00000000		0 0																														
ID	R/W	Field	Value ID	Value	Description																											
A	RW	OVERRUN			Overrun error																											
		W1C			A new byte was received before previous byte got transferred into RXD buffer. (Previous data is lost)																											
			NotReceived	0	Error did not occur																											
			Received	1	Error occurred																											
B	RW	ANACK			NACK received after sending the address (write '1' to clear)																											
		W1C																														
			NotReceived	0	Error did not occur																											
			Received	1	Error occurred																											
C	RW	DNACK			NACK received after sending a data byte (write '1' to clear)																											
		W1C																														
			NotReceived	0	Error did not occur																											
			Received	1	Error occurred																											

6.17.8.30 ENABLE

Address offset: 0x500

Enable TWIM

Bit number	31	30	29	28	27	26	25	24	23	22	21	20	19	18	17	16	15	14	13	12	11	10	9	8	7	6	5	4	3	2	1	0
ID																												A	A	A	A	
Reset 0x00000000	0 0																															
ID	R/W	Field	Value ID	Value	Description																											
A	RW	ENABLE			Enable or disable TWIM																											
			Disabled	0	Disable TWIM																											
			Enabled	6	Enable TWIM																											

6.17.8.31 PSEL.SCL

Address offset: 0x508

Pin select for SCL signal

Bit number	31	30	29	28	27	26	25	24	23	22	21	20	19	18	17	16	15	14	13	12	11	10	9	8	7	6	5	4	3	2	1	0
ID	B																											A	A	A	A	A
Reset 0xFFFFFFFF	1 1																															
ID	R/W	Field	Value ID	Value	Description																											
A	RW	PIN		[0..31]	Pin number																											
B	RW	CONNECT			Connection																											
			Disconnected	1	Disconnect																											
			Connected	0	Connect																											

6.17.8.32 PSEL.SDA

Address offset: 0x50C

Pin select for SDA signal

Bit number	31	30	29	28	27	26	25	24	23	22	21	20	19	18	17	16	15	14	13	12	11	10	9	8	7	6	5	4	3	2	1	0
ID	B																											A	A	A	A	A
Reset 0xFFFFFFFF	1 1																															
ID	R/W	Field	Value ID	Value	Description																											
A	RW	PIN		[0..31]	Pin number																											
B	RW	CONNECT			Connection																											
			Disconnected	1	Disconnect																											
			Connected	0	Connect																											

6.17.8.33 FREQUENCY

Address offset: 0x524

TWI frequency. Accuracy depends on the HFCLK source selected.

Bit number	31	30	29	28	27	26	25	24	23	22	21	20	19	18	17	16	15	14	13	12	11	10	9	8	7	6	5	4	3	2	1	0
ID	A	A	A	A	A	A	A	A	A	A	A	A	A	A	A	A	A	A	A	A	A	A	A	A	A	A	A	A	A	A	A	
Reset 0x04000000	0 0 0 0 0 1 0																															
ID	R/W	Field	Value ID	Value	Description																											
A	RW	FREQUENCY			TWI master clock frequency																											
			K100	0x01980000	100 kbps																											
			K250	0x04000000	250 kbps																											
			K400	0x06400000	400 kbps																											

6.17.8.34 RXD

RXD EasyDMA channel

6.17.8.34.1 RXD.PTR

Address offset: 0x534

Data pointer

Bit number	31	30	29	28	27	26	25	24	23	22	21	20	19	18	17	16	15	14	13	12	11	10	9	8	7	6	5	4	3	2	1	0
ID	A	A	A	A	A	A	A	A	A	A	A	A	A	A	A	A	A	A	A	A	A	A	A	A	A	A	A	A	A	A	A	A
Reset 0x00000000	0	0	0	0	0	0	0	0	0	0	0	0	0	0	0	0	0	0	0	0	0	0	0	0	0	0	0	0	0	0	0	0

ID	R/W	Field	Value ID	Value	Description
A	RW	PTR			Data pointer

See the memory chapter for details about which memories are available for EasyDMA.

6.17.8.34.2 RXD.MAXCNT

Address offset: 0x538

Maximum number of bytes in receive buffer

Bit number	31	30	29	28	27	26	25	24	23	22	21	20	19	18	17	16	15	14	13	12	11	10	9	8	7	6	5	4	3	2	1	0
ID																						A	A	A	A	A	A	A	A	A	A	A
Reset 0x00000000	0	0	0	0	0	0	0	0	0	0	0	0	0	0	0	0	0	0	0	0	0	0	0	0	0	0	0	0	0	0	0	

ID	R/W	Field	Value ID	Value	Description
A	RW	MAXCNT		[1..0x1FFF]	Maximum number of bytes in receive buffer

6.17.8.34.3 RXD.AMOUNT

Address offset: 0x53C

Number of bytes transferred in the last transaction

Bit number	31	30	29	28	27	26	25	24	23	22	21	20	19	18	17	16	15	14	13	12	11	10	9	8	7	6	5	4	3	2	1	0
ID																							A	A	A	A	A	A	A	A	A	A
Reset 0x00000000	0	0	0	0	0	0	0	0	0	0	0	0	0	0	0	0	0	0	0	0	0	0	0	0	0	0	0	0	0	0	0	

ID	R/W	Field	Value ID	Value	Description
A	R	AMOUNT		[1..0x1FFF]	Number of bytes transferred in the last transaction. In case of NACK error, includes the NACK'ed byte.

6.17.8.34.4 RXD.LIST

Address offset: 0x540

EasyDMA list type

Bit number	31	30	29	28	27	26	25	24	23	22	21	20	19	18	17	16	15	14	13	12	11	10	9	8	7	6	5	4	3	2	1	0	
ID																																A	A
Reset 0x00000000	0	0	0	0	0	0	0	0	0	0	0	0	0	0	0	0	0	0	0	0	0	0	0	0	0	0	0	0	0	0	0	0	

ID	R/W	Field	Value ID	Value	Description
A	RW	LIST			List type
			Disabled	0	Disable EasyDMA list
			ArrayList	1	Use array list

6.17.8.35 TXD

TXD EasyDMA channel

6.17.8.35.1 TXD.PTR

Address offset: 0x544

Data pointer

Bit number	31	30	29	28	27	26	25	24	23	22	21	20	19	18	17	16	15	14	13	12	11	10	9	8	7	6	5	4	3	2	1	0
ID	A	A	A	A	A	A	A	A	A	A	A	A	A	A	A	A	A	A	A	A	A	A	A	A	A	A	A	A	A	A	A	A
Reset 0x00000000	0	0	0	0	0	0	0	0	0	0	0	0	0	0	0	0	0	0	0	0	0	0	0	0	0	0	0	0	0	0	0	0

ID	R/W	Field	Value ID	Value	Description
A	RW	PTR			Data pointer

See the memory chapter for details about which memories are available for EasyDMA.

6.17.8.35.2 TXD.MAXCNT

Address offset: 0x548

Maximum number of bytes in transmit buffer

Bit number	31	30	29	28	27	26	25	24	23	22	21	20	19	18	17	16	15	14	13	12	11	10	9	8	7	6	5	4	3	2	1	0
ID																						A	A	A	A	A	A	A	A	A	A	A
Reset 0x00000000	0	0	0	0	0	0	0	0	0	0	0	0	0	0	0	0	0	0	0	0	0	0	0	0	0	0	0	0	0	0	0	0

ID	R/W	Field	Value ID	Value	Description
A	RW	MAXCNT		[1..0x1FFF]	Maximum number of bytes in transmit buffer

6.17.8.35.3 TXD.AMOUNT

Address offset: 0x54C

Number of bytes transferred in the last transaction

Bit number	31	30	29	28	27	26	25	24	23	22	21	20	19	18	17	16	15	14	13	12	11	10	9	8	7	6	5	4	3	2	1	0
ID																							A	A	A	A	A	A	A	A	A	A
Reset 0x00000000	0	0	0	0	0	0	0	0	0	0	0	0	0	0	0	0	0	0	0	0	0	0	0	0	0	0	0	0	0	0	0	0

ID	R/W	Field	Value ID	Value	Description
A	R	AMOUNT		[1..0x1FFF]	Number of bytes transferred in the last transaction. In case of NACK error, includes the NACK'ed byte.

6.17.8.35.4 TXD.LIST

Address offset: 0x550

EasyDMA list type

Bit number	31	30	29	28	27	26	25	24	23	22	21	20	19	18	17	16	15	14	13	12	11	10	9	8	7	6	5	4	3	2	1	0	
ID																																A	A
Reset 0x00000000	0	0	0	0	0	0	0	0	0	0	0	0	0	0	0	0	0	0	0	0	0	0	0	0	0	0	0	0	0	0	0	0	

ID	R/W	Field	Value ID	Value	Description
A	RW	LIST			List type
			Disabled	0	Disable EasyDMA list
			ArrayList	1	Use array list

6.17.8.36 ADDRESS

Address offset: 0x588

Address used in the TWI transfer

Bit number	31	30	29	28	27	26	25	24	23	22	21	20	19	18	17	16	15	14	13	12	11	10	9	8	7	6	5	4	3	2	1	0
ID	A A A A A A A A																															
Reset 0x00000000	0 0																															
ID	R/W	Field	Value ID	Value	Description																											
A	RW	ADDRESS			Address used in the TWI transfer																											

6.17.9 Electrical specification

6.17.9.1 TWIM interface electrical specifications

Symbol	Description	Min.	Typ.	Max.	Units
$f_{TWIM,SCL}$	Bit rates for TWIM ¹⁹	100		400	kbps
$t_{TWIM,START}$	Time from STARTRX/STARTTX task to transmission started		1.615		μ s

6.17.9.2 Two Wire Interface Master (TWIM) timing specifications

Symbol	Description	Min.	Typ.	Max.	Units
t_{TWIM,SU_DAT}	Data setup time before positive edge on SCL – all modes	300			ns
t_{TWIM,HD_DAT}	Data hold time after negative edge on SCL – 100, 250 and 400 kbps	500			ns
$t_{TWIM,HD_STA,100kbps}$	TWIM master hold time for START and repeated START condition, 100 kbps	10000			ns
$t_{TWIM,HD_STA,250kbps}$	TWIM master hold time for START and repeated START condition, 250 kbps	4000			ns
$t_{TWIM,HD_STA,400kbps}$	TWIM master hold time for START and repeated START condition, 400 kbps	2500			ns
$t_{TWIM,SU_STO,100kbps}$	TWIM master setup time from SCL high to STOP condition, 100 kbps	5000			ns
$t_{TWIM,SU_STO,250kbps}$	TWIM master setup time from SCL high to STOP condition, 250 kbps	2000			ns
$t_{TWIM,SU_STO,400kbps}$	TWIM master setup time from SCL high to STOP condition, 400 kbps	1250			ns
$t_{TWIM,BUF,100kbps}$	TWIM master bus free time between STOP and START conditions, 100 kbps	5800			ns
$t_{TWIM,BUF,250kbps}$	TWIM master bus free time between STOP and START conditions, 250 kbps	2700			ns
$t_{TWIM,BUF,400kbps}$	TWIM master bus free time between STOP and START conditions, 400 kbps	2100			ns

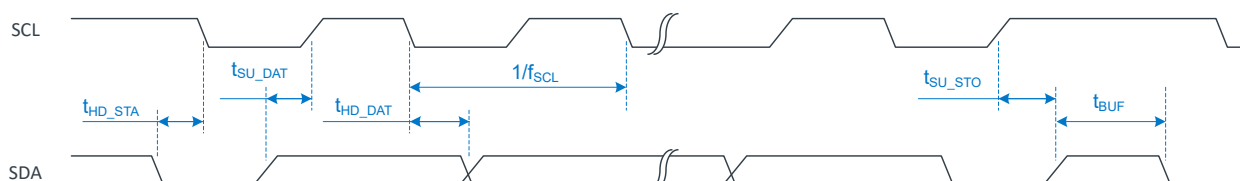

Figure 100: TWIM timing diagram, 1 byte transaction

¹⁹ High bit rates or stronger pull-ups may require GPIOs to be set as High Drive, see [GPIO — General purpose input/output](#) on page 164 for more details.

6.17.10 Pullup resistor

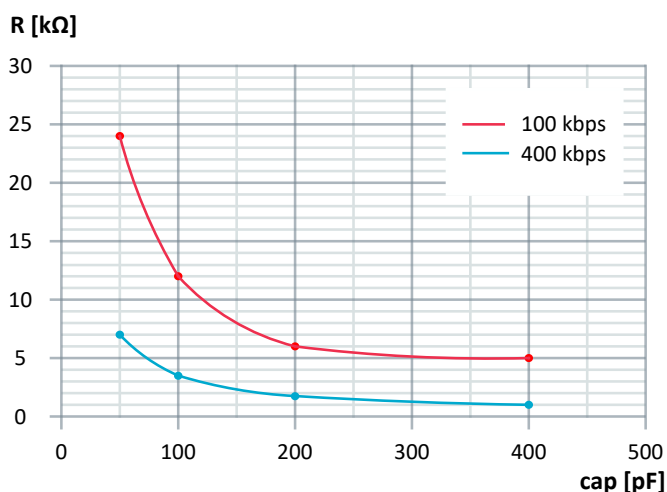

Figure 101: Recommended TWIM pullup value vs. line capacitance

- The I2C specification allows a line capacitance of 400 pF at most.
- The value of internal pullup resistor (R_{PU}) for nRF9160 can be found in [GPIO — General purpose input/output](#) on page 164.

6.18 TWIS — I²C compatible two-wire interface slave with EasyDMA

TWI slave with EasyDMA (TWIS) is compatible with I²C operating at 100 kHz and 400 kHz. The TWI transmitter and receiver implement EasyDMA.

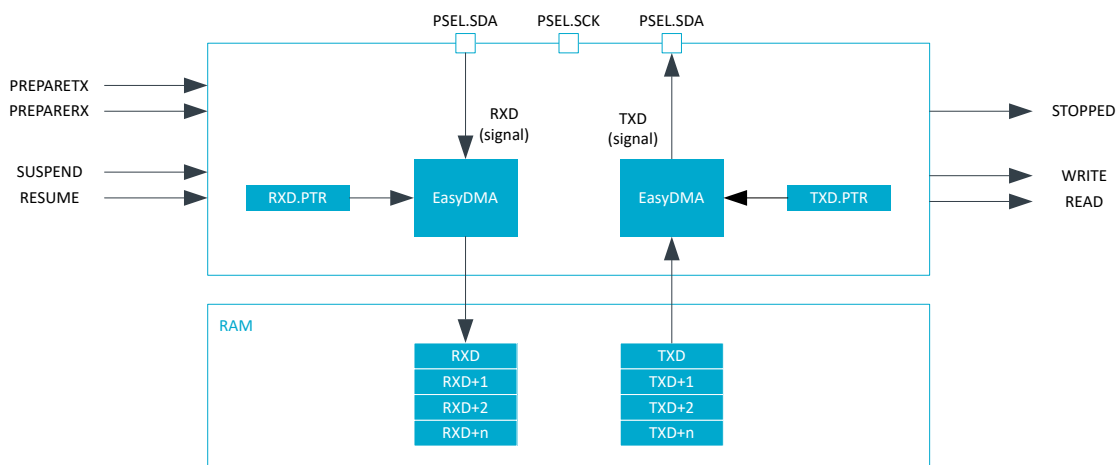

Figure 102: TWI slave with EasyDMA

A typical TWI setup consists of one master and one or more slaves. For an example, see the following figure. TWIS is only able to operate with a single master on the TWI bus.

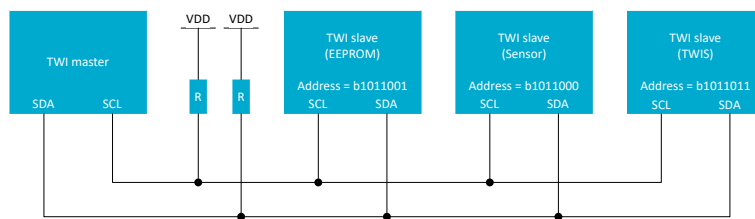

Figure 103: A typical TWI setup comprising one master and three slaves

The following figure shows the TWI slave state machine.

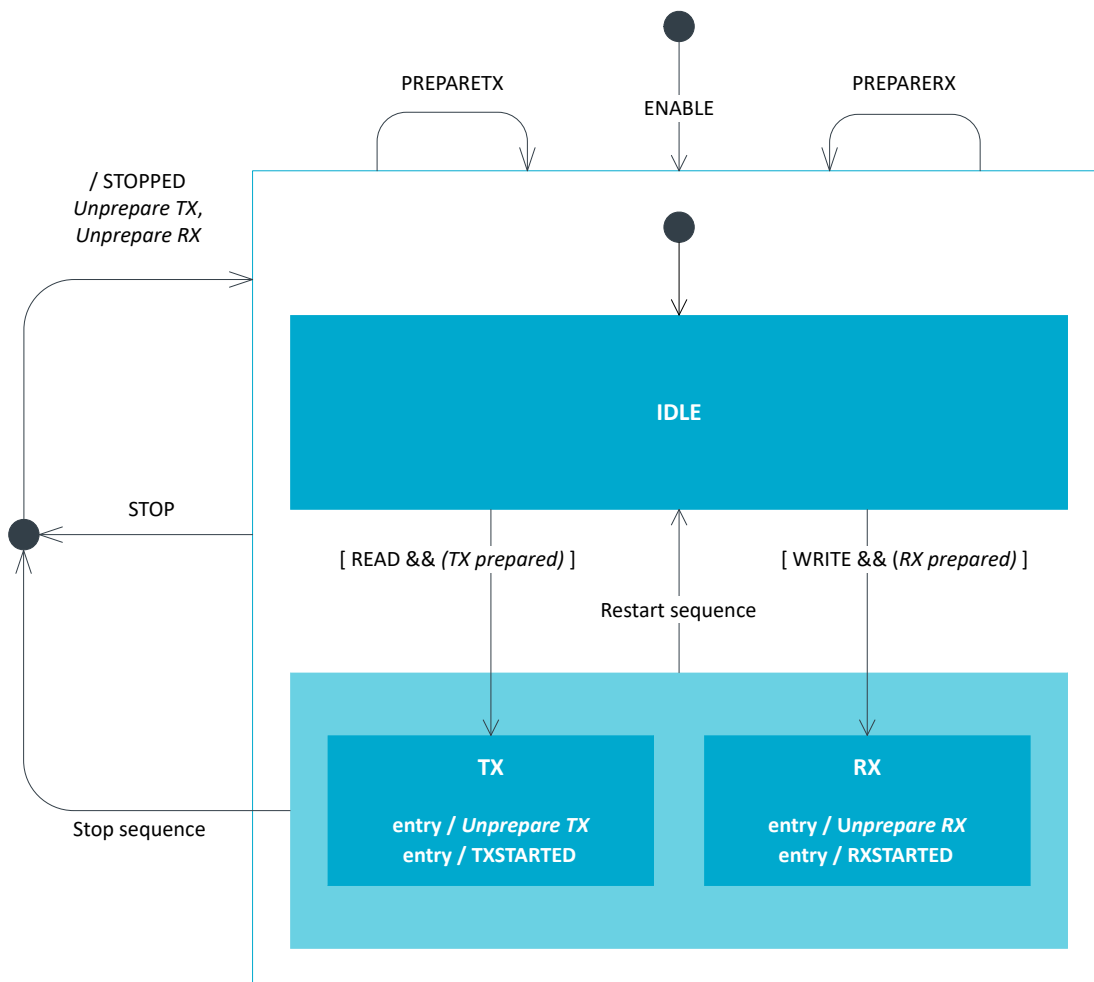

Figure 104: TWI slave state machine

The following table contains descriptions of the symbols used in the state machine.

Symbol	Type	Description
ENABLE	Register	The TWI slave has been enabled via the <code>ENABLE</code> register.
PREPARETX	Task	The <code>TASKS_PREPARETX</code> task has been triggered.
STOP	Task	The <code>TASKS_STOP</code> task has been triggered.
PREPARERX	Task	The <code>TASKS_PREPARERX</code> task has been triggered.
STOPPED	Event	The <code>EVENTS_STOPPED</code> event was generated.
RXSTARTED	Event	The <code>EVENTS_RXSTARTED</code> event was generated.
TXSTARTED	Event	The <code>EVENTS_TXSTARTED</code> event was generated.
TX prepared	Internal	Internal flag indicating that a <code>TASKS_PREPARETX</code> task has been triggered. This flag is not visible to the user.
RX prepared	Internal	Internal flag indicating that a <code>TASKS_PREPARERX</code> task has been triggered. This flag is not visible to the user.
Unprepare TX	Internal	Clears the internal 'TX prepared' flag until next <code>TASKS_PREPARETX</code> task.
Unprepare RX	Internal	Clears the internal 'RX prepared' flag until next <code>TASKS_PREPARERX</code> task.
Stop condition	TWI protocol	A TWI stop condition was detected.
Restart condition	TWI protocol	A TWI restart condition was detected.

Table 46: TWI slave state machine symbols

The TWI slave can perform clock stretching, with the premise that the master is able to support it.

The TWI slave operates in a low power mode while waiting for a TWI master to initiate a transfer. As long as the TWI slave is not addressed, it will remain in this low power mode.

To secure correct behavior of the TWI slave, `PSEL.SCL`, `PSEL.SDA`, `CONFIG`, and the `ADDRESS[n]` registers must be configured prior to enabling the TWI slave through the `ENABLE` register. Similarly, changing these settings must be performed while the TWI slave is disabled. Failing to do so may result in unpredictable behavior.

6.18.1 Shared resources

The TWI slave shares registers and other resources with other peripherals that have the same ID as the TWI slave.

Therefore, you must disable all peripherals that have the same ID as the TWI slave before the TWI slave can be configured and used. Disabling a peripheral that has the same ID as the TWI slave will not reset any of the registers that are shared with the TWI slave. It is therefore important to configure all relevant registers explicitly to secure that the TWI slave operates correctly.

The Instantiation table in [Instantiation](#) on page 27 shows which peripherals have the same ID as the TWI slave.

6.18.2 EasyDMA

The TWIS implements EasyDMA for accessing RAM without CPU involvement.

The following table shows the Easy DMA channels that the TWIS peripheral implements.

Channel	Type	Register Cluster
TXD	READER	TXD
RXD	WRITER	RXD

Table 47: TWIS EasyDMA Channels

For detailed information regarding the use of EasyDMA, see [EasyDMA](#) on page 48.

The STOPPED event indicates that EasyDMA has finished accessing the buffer in RAM.

6.18.3 TWI slave responding to a read command

Before the TWI slave can respond to a read command, the TWI slave must be configured correctly and enabled via the ENABLE register. When enabled, the TWI slave will be in its IDLE state. .

A read command is started when the TWI master generates a start condition on the TWI bus, followed by clocking out the address and the READ/WRITE bit set to 1 (WRITE=0, READ=1). The READ/WRITE bit is followed by an ACK/NACK bit (ACK=0 or NACK=1) response from the TWI slave.

The TWI slave can listen for up to two addresses at the same time. This is configured in the ADDRESS registers and the CONFIG register.

The TWI slave will only acknowledge (ACK) the read command if the address presented by the master matches one of the addresses the slave is configured to listen for. The TWI slave will generate a READ event when it acknowledges the read command.

The TWI slave can only detect a read command from the IDLE state.

The TWI slave will set an internal 'TX prepared' flag when the PREPARETX task is triggered.

When the read command is received, the TWI slave will enter the TX state if the internal 'TX prepared' flag is set.

If the internal 'TX prepared' flag is not set when the read command is received, the TWI slave will stretch the master's clock until the PREPARETX task is triggered and the internal 'TX prepared' flag is set.

The TWI slave will generate the TXSTARTED event and clear the 'TX prepared' flag ('unprepare TX') when it enters the TX state. In this state the TWI slave will send the data bytes found in the transmit buffer to the master using the master's clock.

The TWI slave will go back to the IDLE state if the TWI slave receives a restart command when it is in the TX state.

The TWI slave is stopped when it receives the stop condition from the TWI master. A STOPPED event will be generated when the transaction has stopped. The TWI slave will clear the 'TX prepared' flag ('unprepare TX') and go back to the IDLE state when it has stopped.

The transmit buffer is located in RAM at the address specified in the TXD.PTR register. The TWI slave will only be able to send TXD.MAXCNT bytes from the transmit buffer for each transaction. If the TWI master forces the slave to send more than TXD.MAXCNT bytes, the slave will send the byte specified in the ORC register to the master instead. If this happens, an ERROR event will be generated.

The EasyDMA configuration registers, see TXD.PTR etc., are latched when the TXSTARTED event is generated.

The TWI slave can be forced to stop by triggering the STOP task. A STOPPED event will be generated when the TWI slave has stopped. The TWI slave will clear the 'TX prepared' flag and go back to the IDLE state when it has stopped, see also [Terminating an ongoing TWI transaction](#) on page 381.

Each byte sent from the slave will be followed by an ACK/NACK bit sent from the master. The TWI master will generate a NACK following the last byte that it wants to receive to tell the slave to release the bus so that the TWI master can generate the stop condition. The TXD.AMOUNT register can be queried after a transaction to see how many bytes were sent.

A typical TWI slave read command response is shown in the following figure. Occurrence 2 in the figure illustrates clock stretching performed by the TWI slave following a SUSPEND task.

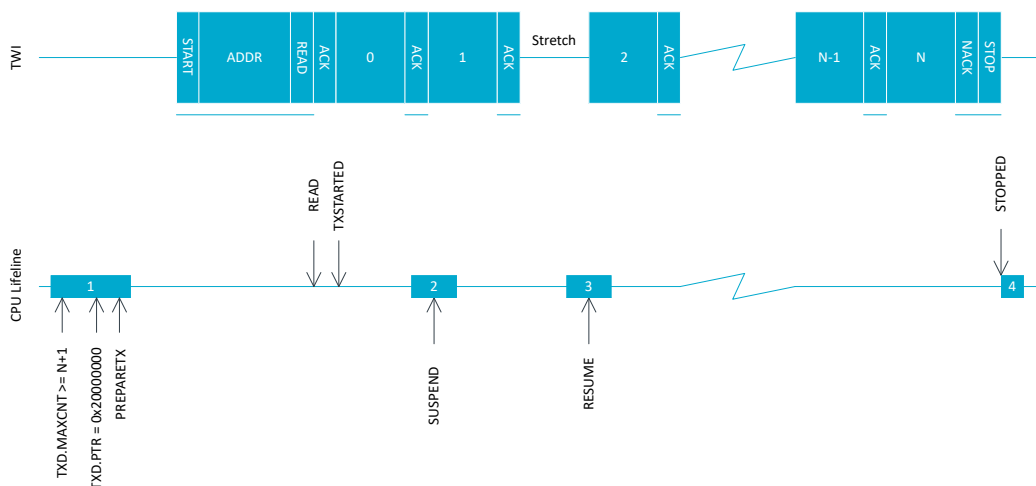

Figure 105: The TWI slave responding to a read command

6.18.4 TWI slave responding to a write command

Before the TWI slave can respond to a write command, the TWI slave must be configured correctly and enabled via the ENABLE register. When enabled, the TWI slave will be in its IDLE state.

A write command is started when the TWI master generates a start condition on the TWI bus, followed by clocking out the address and the READ/WRITE bit set to 0 (WRITE=0, READ=1). The READ/WRITE bit is followed by an ACK/NACK bit (ACK=0 or NACK=1) response from the slave.

The TWI slave can listen for up to two addresses at the same time. This is configured in the ADDRESS registers and the CONFIG register.

The TWI slave will only acknowledge (ACK) the write command if the address presented by the master matches one of the addresses the slave is configured to listen for. The TWI slave will generate a WRITE event if it acknowledges the write command.

The TWI slave can only detect a write command from the IDLE state.

The TWI slave will set an internal 'RX prepared' flag when the PREPARERX task is triggered.

When the write command is received, the TWI slave will enter the RX state if the internal 'RX prepared' flag is set.

If the internal 'RX prepared' flag is not set when the write command is received, the TWI slave will stretch the master's clock until the PREPARERX task is triggered and the internal 'RX prepared' flag is set.

The TWI slave will generate the RXSTARTED event and clear the internal 'RX prepared' flag ('unprepare RX') when it enters the RX state. In this state, the TWI slave will be able to receive the bytes sent by the TWI master.

The TWI slave will go back to the IDLE state if the TWI slave receives a restart command when it is in the RX state.

The TWI slave is stopped when it receives the stop condition from the TWI master. A STOPPED event will be generated when the transaction has stopped. The TWI slave will clear the internal 'RX prepared' flag ('unprepare RX') and go back to the IDLE state when it has stopped.

The receive buffer is located in RAM at the address specified in the RXD.PTR register. The TWI slave will only be able to receive as many bytes as specified in the RXD.MAXCNT register. If the TWI master tries to send more bytes to the slave than it can receive, the extra bytes are discarded and NACKED by the slave. If this happens, an ERROR event will be generated.

The EasyDMA configuration registers, see RXD.PTR etc., are latched when the RXSTARTED event is generated.

The TWI slave can be forced to stop by triggering the STOP task. A STOPPED event will be generated when the TWI slave has stopped. The TWI slave will clear the internal 'RX prepared' flag and go back to the IDLE state when it has stopped, see also [Terminating an ongoing TWI transaction](#) on page 381.

The TWI slave will generate an ACK after every byte received from the master. The RXD.AMOUNT register can be queried after a transaction to see how many bytes were received.

A typical TWI slave write command response is show in the following figure. Occurrence 2 in the figure illustrates clock stretching performed by the TWI slave following a SUSPEND task.

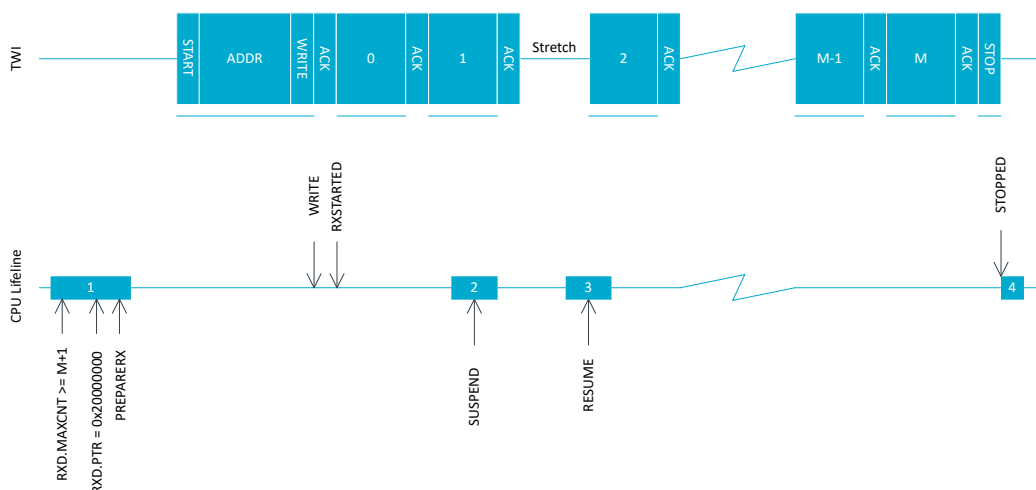

Figure 106: The TWI slave responding to a write command

6.18.5 Master repeated start sequence

An example of a repeated start sequence is one in which the TWI master writes two bytes to the slave followed by reading four bytes from the slave.

This is illustrated in the following figure.

In this example, the receiver does not know what the master wants to read in advance. This information is in the first two received bytes of the write in the repeated start sequence. To guarantee that the CPU is able to process the received data before the TWI slave starts to reply to the read command, the SUSPEND task is triggered via a shortcut from the READ event generated when the read command is received. When the CPU has processed the incoming data and prepared the correct data response, the CPU will resume the transaction by triggering the RESUME task.

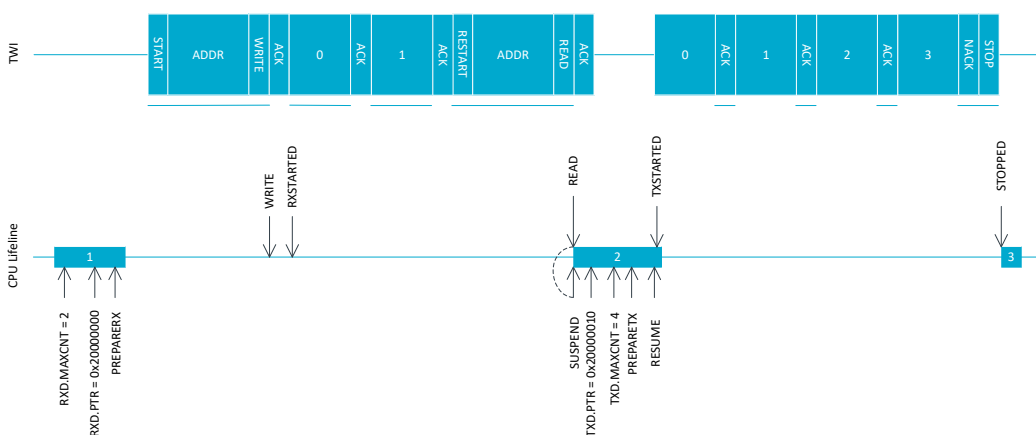

Figure 107: Repeated start sequence

6.18.6 Terminating an ongoing TWI transaction

In some situations, e.g. if the external TWI master is not responding correctly, it may be required to terminate an ongoing transaction.

This can be achieved by triggering the STOP task. In this situation, a STOPPED event will be generated when the TWI has stopped independent of whether or not a STOP condition has been generated on the TWI bus. The TWI slave will release the bus when it has stopped and go back to its IDLE state.

6.18.7 Low power

When putting the system in low power and the peripheral is not needed, lowest possible power consumption is achieved by stopping, and then disabling the peripheral.

The STOP task may not be always needed (the peripheral might already be stopped), but if it is sent, software shall wait until the STOPPED event was received as a response before disabling the peripheral through the ENABLE register.

6.18.8 Slave mode pin configuration

The SCL and SDA signals associated with the TWI slave are mapped to physical pins according to the configuration specified in the PSEL.SCL and PSEL.SDA registers respectively.

The PSEL.SCL and PSEL.SDA registers and their configurations are only used as long as the TWI slave is enabled, and retained only as long as the device is in ON mode. When the peripheral is disabled, the pins will behave as regular GPIOs, and use the configuration in their respective OUT bit field and PIN_CNF[n] register. PSEL.SCL and PSEL.SDA must only be configured when the TWI slave is disabled.

To secure correct signal levels on the pins used by the TWI slave when the system is in OFF mode, and when the TWI slave is disabled, these pins must be configured in the GPIO peripheral as described in the following table.

Only one peripheral can be assigned to drive a particular GPIO pin at a time. Failing to do so may result in unpredictable behavior.

TWI slave signal	TWI slave pin	Direction	Output value	Drive strength
SCL	As specified in PSEL.SCL	Input	Not applicable	S0D1
SDA	As specified in PSEL.SDA	Input	Not applicable	S0D1

Table 48: GPIO configuration before enabling peripheral

6.18.9 Registers

Instances

Instance	Base address	TrustZone			Split access	Description
		Map	Att	DMA		
TWIS0 : S	0x50008000	US	NS	SA	No	Two-wire interface slave 0
TWIS0 : NS	0x40008000					
TWIS1 : S	0x50009000	US	NS	SA	No	Two-wire interface slave 1
TWIS1 : NS	0x40009000					
TWIS2 : S	0x5000A000	US	NS	SA	No	Two-wire interface slave 2
TWIS2 : NS	0x4000A000					
TWIS3 : S	0x5000B000	US	NS	SA	No	Two-wire interface slave 3
TWIS3 : NS	0x4000B000					

Register overview

Register	Offset	TZ	Description
TASKS_STOP	0x014		Stop TWI transaction
TASKS_SUSPEND	0x01C		Suspend TWI transaction
TASKS_RESUME	0x020		Resume TWI transaction
TASKS_PREPARERX	0x030		Prepare the TWI slave to respond to a write command
TASKS_PREPARETX	0x034		Prepare the TWI slave to respond to a read command
SUBSCRIBE_STOP	0x094		Subscribe configuration for task STOP
SUBSCRIBE_SUSPEND	0x09C		Subscribe configuration for task SUSPEND
SUBSCRIBE_RESUME	0x0A0		Subscribe configuration for task RESUME
SUBSCRIBE_PREPARERX	0x0B0		Subscribe configuration for task PREPARERX
SUBSCRIBE_PREPARETX	0x0B4		Subscribe configuration for task PREPARETX
EVENTS_STOPPED	0x104		TWI stopped
EVENTS_ERROR	0x124		TWI error
EVENTS_RXSTARTED	0x14C		Receive sequence started
EVENTS_TXSTARTED	0x150		Transmit sequence started
EVENTS_WRITE	0x164		Write command received
EVENTS_READ	0x168		Read command received
PUBLISH_STOPPED	0x184		Publish configuration for event STOPPED
PUBLISH_ERROR	0x1A4		Publish configuration for event ERROR
PUBLISH_RXSTARTED	0x1CC		Publish configuration for event RXSTARTED
PUBLISH_TXSTARTED	0x1D0		Publish configuration for event TXSTARTED
PUBLISH_WRITE	0x1E4		Publish configuration for event WRITE
PUBLISH_READ	0x1E8		Publish configuration for event READ
SHORTS	0x200		Shortcuts between local events and tasks
INTEN	0x300		Enable or disable interrupt
INTENSET	0x304		Enable interrupt
INTENCLR	0x308		Disable interrupt
ERRORSRC	0x4D0		Error source
MATCH	0x4D4		Status register indicating which address had a match
ENABLE	0x500		Enable TWIS
PSEL.SCL	0x508		Pin select for SCL signal
PSEL.SDA	0x50C		Pin select for SDA signal
RXD.PTR	0x534		RXD Data pointer
RXD.MAXCNT	0x538		Maximum number of bytes in RXD buffer
RXD.AMOUNT	0x53C		Number of bytes transferred in the last RXD transaction
RXD.LIST	0x540		EasyDMA list type
TXD.PTR	0x544		TXD Data pointer
TXD.MAXCNT	0x548		Maximum number of bytes in TXD buffer
TXD.AMOUNT	0x54C		Number of bytes transferred in the last TXD transaction
TXD.LIST	0x550		EasyDMA list type
ADDRESS[n]	0x588		TWI slave address n
CONFIG	0x594		Configuration register for the address match mechanism
ORC	0x5C0		Over-read character. Character sent out in case of an over-read of the transmit buffer.

6.18.9.1 TASKS_STOP

Address offset: 0x014

Stop TWI transaction

Bit number	31 30 29 28 27 26 25 24 23 22 21 20 19 18 17 16 15 14 13 12 11 10 9 8 7 6 5 4 3 2 1 0																														
ID	A																														
Reset 0x00000000	0 0																														
ID	R/W	Field	Value ID	Value	Description																										
A	W	TASKS_STOP			Stop TWI transaction																										
			Trigger	1	Trigger task																										

6.18.9.2 TASKS_SUSPEND

Address offset: 0x01C

Suspend TWI transaction

Bit number	31 30 29 28 27 26 25 24 23 22 21 20 19 18 17 16 15 14 13 12 11 10 9 8 7 6 5 4 3 2 1 0																														
ID	A																														
Reset 0x00000000	0 0																														
ID	R/W	Field	Value ID	Value	Description																										
A	W	TASKS_SUSPEND			Suspend TWI transaction																										
			Trigger	1	Trigger task																										

6.18.9.3 TASKS_RESUME

Address offset: 0x020

Resume TWI transaction

Bit number	31 30 29 28 27 26 25 24 23 22 21 20 19 18 17 16 15 14 13 12 11 10 9 8 7 6 5 4 3 2 1 0																														
ID	A																														
Reset 0x00000000	0 0																														
ID	R/W	Field	Value ID	Value	Description																										
A	W	TASKS_RESUME			Resume TWI transaction																										
			Trigger	1	Trigger task																										

6.18.9.4 TASKS_PREPARERX

Address offset: 0x030

Prepare the TWI slave to respond to a write command

Bit number	31 30 29 28 27 26 25 24 23 22 21 20 19 18 17 16 15 14 13 12 11 10 9 8 7 6 5 4 3 2 1 0																														
ID	A																														
Reset 0x00000000	0 0																														
ID	R/W	Field	Value ID	Value	Description																										
A	W	TASKS_PREPARERX			Prepare the TWI slave to respond to a write command																										
			Trigger	1	Trigger task																										

6.18.9.5 TASKS_PREPARETX

Address offset: 0x034

Prepare the TWI slave to respond to a read command

Bit number	31	30	29	28	27	26	25	24	23	22	21	20	19	18	17	16	15	14	13	12	11	10	9	8	7	6	5	4	3	2	1	0
ID	A																															
Reset 0x00000000	0 0																															
ID	R/W	Field	Value ID	Value	Description																											
A	W	TASKS_PREPARETX			Prepare the TWI slave to respond to a read command																											
			Trigger	1	Trigger task																											

6.18.9.6 SUBSCRIBE_STOP

Address offset: 0x094

Subscribe configuration for task STOP

Bit number	31	30	29	28	27	26	25	24	23	22	21	20	19	18	17	16	15	14	13	12	11	10	9	8	7	6	5	4	3	2	1	0					
ID	B																											A A A A A A A A									
Reset 0x00000000	0 0																																				
ID	R/W	Field	Value ID	Value	Description																																
A	RW	CHIDX		[0..255]	DPPI channel that task STOP will subscribe to																																
B	RW	EN																																			
			Disabled	0	Disable subscription																																
			Enabled	1	Enable subscription																																

6.18.9.7 SUBSCRIBE_SUSPEND

Address offset: 0x09C

Subscribe configuration for task SUSPEND

Bit number	31	30	29	28	27	26	25	24	23	22	21	20	19	18	17	16	15	14	13	12	11	10	9	8	7	6	5	4	3	2	1	0					
ID	B																											A A A A A A A A									
Reset 0x00000000	0 0																																				
ID	R/W	Field	Value ID	Value	Description																																
A	RW	CHIDX		[0..255]	DPPI channel that task SUSPEND will subscribe to																																
B	RW	EN																																			
			Disabled	0	Disable subscription																																
			Enabled	1	Enable subscription																																

6.18.9.8 SUBSCRIBE_RESUME

Address offset: 0x0A0

Subscribe configuration for task RESUME

Bit number	31	30	29	28	27	26	25	24	23	22	21	20	19	18	17	16	15	14	13	12	11	10	9	8	7	6	5	4	3	2	1	0					
ID	B																											A A A A A A A A									
Reset 0x00000000	0 0																																				
ID	R/W	Field	Value ID	Value	Description																																
A	RW	CHIDX		[0..255]	DPPI channel that task RESUME will subscribe to																																
B	RW	EN																																			
			Disabled	0	Disable subscription																																
			Enabled	1	Enable subscription																																

6.18.9.9 SUBSCRIBE_PREPARERX

Address offset: 0x0B0

Subscribe configuration for task **PREPARERX**

Bit number	31	30	29	28	27	26	25	24	23	22	21	20	19	18	17	16	15	14	13	12	11	10	9	8	7	6	5	4	3	2	1	0
ID	B																A A A A A A A A															
Reset 0x00000000	0 0																															
ID	R/W	Field	Value ID	Value	Description																											
A	RW	CHIDX		[0..255]	DPPI channel that task PREPARERX will subscribe to																											
B	RW	EN	Disabled	0	Disable subscription																											
			Enabled	1	Enable subscription																											

6.18.9.10 **SUBSCRIBE_PREPARETX**

Address offset: 0x0B4

Subscribe configuration for task **PREPARETX**

Bit number	31	30	29	28	27	26	25	24	23	22	21	20	19	18	17	16	15	14	13	12	11	10	9	8	7	6	5	4	3	2	1	0
ID	B																A A A A A A A A															
Reset 0x00000000	0 0																															
ID	R/W	Field	Value ID	Value	Description																											
A	RW	CHIDX		[0..255]	DPPI channel that task PREPARETX will subscribe to																											
B	RW	EN	Disabled	0	Disable subscription																											
			Enabled	1	Enable subscription																											

6.18.9.11 **EVENTS_STOPPED**

Address offset: 0x104

TWI stopped

Bit number	31	30	29	28	27	26	25	24	23	22	21	20	19	18	17	16	15	14	13	12	11	10	9	8	7	6	5	4	3	2	1	0
ID																																A
Reset 0x00000000	0 0																															
ID	R/W	Field	Value ID	Value	Description																											
A	RW	EVENTS_STOPPED			TWI stopped																											
			NotGenerated	0	Event not generated																											
			Generated	1	Event generated																											

6.18.9.12 **EVENTS_ERROR**

Address offset: 0x124

TWI error

Bit number	31	30	29	28	27	26	25	24	23	22	21	20	19	18	17	16	15	14	13	12	11	10	9	8	7	6	5	4	3	2	1	0
ID																																A
Reset 0x00000000	0 0																															
ID	R/W	Field	Value ID	Value	Description																											
A	RW	EVENTS_ERROR			TWI error																											
			NotGenerated	0	Event not generated																											
			Generated	1	Event generated																											

6.18.9.13 EVENTS_RXSTARTED

Address offset: 0x14C

Receive sequence started

Bit number	31	30	29	28	27	26	25	24	23	22	21	20	19	18	17	16	15	14	13	12	11	10	9	8	7	6	5	4	3	2	1	0
ID																																A
Reset 0x00000000	0 0																															
ID	R/W	Field	Value ID	Value	Description																											
A	RW	EVENTS_RXSTARTED			Receive sequence started																											
			NotGenerated	0	Event not generated																											
			Generated	1	Event generated																											

6.18.9.14 EVENTS_TXSTARTED

Address offset: 0x150

Transmit sequence started

Bit number	31	30	29	28	27	26	25	24	23	22	21	20	19	18	17	16	15	14	13	12	11	10	9	8	7	6	5	4	3	2	1	0
ID																																A
Reset 0x00000000	0 0																															
ID	R/W	Field	Value ID	Value	Description																											
A	RW	EVENTS_TXSTARTED			Transmit sequence started																											
			NotGenerated	0	Event not generated																											
			Generated	1	Event generated																											

6.18.9.15 EVENTS_WRITE

Address offset: 0x164

Write command received

Bit number	31	30	29	28	27	26	25	24	23	22	21	20	19	18	17	16	15	14	13	12	11	10	9	8	7	6	5	4	3	2	1	0
ID																																A
Reset 0x00000000	0 0																															
ID	R/W	Field	Value ID	Value	Description																											
A	RW	EVENTS_WRITE			Write command received																											
			NotGenerated	0	Event not generated																											
			Generated	1	Event generated																											

6.18.9.16 EVENTS_READ

Address offset: 0x168

Read command received

Bit number	31	30	29	28	27	26	25	24	23	22	21	20	19	18	17	16	15	14	13	12	11	10	9	8	7	6	5	4	3	2	1	0
ID																																A
Reset 0x00000000	0 0																															
ID	R/W	Field	Value ID	Value	Description																											
A	RW	EVENTS_READ			Read command received																											
			NotGenerated	0	Event not generated																											
			Generated	1	Event generated																											

6.18.9.17 PUBLISH_STOPPED

Address offset: 0x184

Publish configuration for event STOPPED

Bit number	31 30 29 28 27 26 25 24 23 22 21 20 19 18 17 16 15 14 13 12 11 10 9 8 7 6 5 4 3 2 1 0																														
ID	B															A A A A A A A A															
Reset 0x00000000	0 0																														
ID	R/W	Field	Value ID	Value	Description																										
A	RW	CHIDX		[0..255]	DPPI channel that event STOPPED will publish to																										
B	RW	EN	Disabled	0	Disable publishing																										
			Enabled	1	Enable publishing																										

6.18.9.18 PUBLISH_ERROR

Address offset: 0x1A4

Publish configuration for event ERROR

Bit number	31 30 29 28 27 26 25 24 23 22 21 20 19 18 17 16 15 14 13 12 11 10 9 8 7 6 5 4 3 2 1 0																														
ID	B															A A A A A A A A															
Reset 0x00000000	0 0																														
ID	R/W	Field	Value ID	Value	Description																										
A	RW	CHIDX		[0..255]	DPPI channel that event ERROR will publish to																										
B	RW	EN	Disabled	0	Disable publishing																										
			Enabled	1	Enable publishing																										

6.18.9.19 PUBLISH_RXSTARTED

Address offset: 0x1CC

Publish configuration for event RXSTARTED

Bit number	31 30 29 28 27 26 25 24 23 22 21 20 19 18 17 16 15 14 13 12 11 10 9 8 7 6 5 4 3 2 1 0																														
ID	B															A A A A A A A A															
Reset 0x00000000	0 0																														
ID	R/W	Field	Value ID	Value	Description																										
A	RW	CHIDX		[0..255]	DPPI channel that event RXSTARTED will publish to																										
B	RW	EN	Disabled	0	Disable publishing																										
			Enabled	1	Enable publishing																										

6.18.9.20 PUBLISH_TXSTARTED

Address offset: 0x1D0

Publish configuration for event TXSTARTED

Bit number	31 30 29 28 27 26 25 24 23 22 21 20 19 18 17 16 15 14 13 12 11 10 9 8 7 6 5 4 3 2 1 0																															
ID	B																A A A A A A A A															
Reset 0x00000000	0 0																															
ID	R/W	Field	Value ID	Value	Description																											
A	RW	CHIDX		[0..255]	DPPI channel that event TXSTARTED will publish to																											
B	RW	EN	Disabled	0	Disable publishing																											
			Enabled	1	Enable publishing																											

6.18.9.21 PUBLISH_WRITE

Address offset: 0x1E4

Publish configuration for event **WRITE**

Bit number	31 30 29 28 27 26 25 24 23 22 21 20 19 18 17 16 15 14 13 12 11 10 9 8 7 6 5 4 3 2 1 0																															
ID	B																A A A A A A A A															
Reset 0x00000000	0 0																															
ID	R/W	Field	Value ID	Value	Description																											
A	RW	CHIDX		[0..255]	DPPI channel that event WRITE will publish to																											
B	RW	EN	Disabled	0	Disable publishing																											
			Enabled	1	Enable publishing																											

6.18.9.22 PUBLISH_READ

Address offset: 0x1E8

Publish configuration for event **READ**

Bit number	31 30 29 28 27 26 25 24 23 22 21 20 19 18 17 16 15 14 13 12 11 10 9 8 7 6 5 4 3 2 1 0																															
ID	B																A A A A A A A A															
Reset 0x00000000	0 0																															
ID	R/W	Field	Value ID	Value	Description																											
A	RW	CHIDX		[0..255]	DPPI channel that event READ will publish to																											
B	RW	EN	Disabled	0	Disable publishing																											
			Enabled	1	Enable publishing																											

6.18.9.23 SHORTS

Address offset: 0x200

Shortcuts between local events and tasks

Bit number	31 30 29 28 27 26 25 24 23 22 21 20 19 18 17 16 15 14 13 12 11 10 9 8 7 6 5 4 3 2 1 0																															
ID																	B A															
Reset 0x00000000	0 0																															
ID	R/W	Field	Value ID	Value	Description																											
A	RW	WRITE_SUSPEND			Shortcut between event WRITE and task SUSPEND																											
			Disabled	0	Disable shortcut																											
			Enabled	1	Enable shortcut																											
B	RW	READ_SUSPEND			Shortcut between event READ and task SUSPEND																											
			Disabled	0	Disable shortcut																											
			Enabled	1	Enable shortcut																											

6.18.9.24 INTEN

Address offset: 0x300

Enable or disable interrupt

Bit number	31 30 29 28 27 26 25 24 23 22 21 20 19 18 17 16 15 14 13 12 11 10 9 8 7 6 5 4 3 2 1 0																														
ID	H G						F E						B						A												
Reset 0x00000000	0 0																														
ID	R/W	Field	Value ID	Value	Description																										
A	RW	STOPPED			Enable or disable interrupt for event STOPPED																										
			Disabled	0	Disable																										
			Enabled	1	Enable																										
B	RW	ERROR			Enable or disable interrupt for event ERROR																										
			Disabled	0	Disable																										
			Enabled	1	Enable																										
E	RW	RXSTARTED			Enable or disable interrupt for event RXSTARTED																										
			Disabled	0	Disable																										
			Enabled	1	Enable																										
F	RW	TXSTARTED			Enable or disable interrupt for event TXSTARTED																										
			Disabled	0	Disable																										
			Enabled	1	Enable																										
G	RW	WRITE			Enable or disable interrupt for event WRITE																										
			Disabled	0	Disable																										
			Enabled	1	Enable																										
H	RW	READ			Enable or disable interrupt for event READ																										
			Disabled	0	Disable																										
			Enabled	1	Enable																										

6.18.9.25 INTENSET

Address offset: 0x304

Enable interrupt

Bit number	31 30 29 28 27 26 25 24 23 22 21 20 19 18 17 16 15 14 13 12 11 10 9 8 7 6 5 4 3 2 1 0																														
ID	H G						F E						B						A												
Reset 0x00000000	0 0																														
ID	R/W	Field	Value ID	Value	Description																										
A	RW	STOPPED			Write '1' to enable interrupt for event STOPPED																										
			Set	1	Enable																										
			Disabled	0	Read: Disabled																										
			Enabled	1	Read: Enabled																										
B	RW	ERROR			Write '1' to enable interrupt for event ERROR																										
			Set	1	Enable																										
			Disabled	0	Read: Disabled																										
			Enabled	1	Read: Enabled																										
E	RW	RXSTARTED			Write '1' to enable interrupt for event RXSTARTED																										
			Set	1	Enable																										
			Disabled	0	Read: Disabled																										
			Enabled	1	Read: Enabled																										
F	RW	TXSTARTED			Write '1' to enable interrupt for event TXSTARTED																										
			Set	1	Enable																										
			Disabled	0	Read: Disabled																										
			Enabled	1	Read: Enabled																										

Bit number	31 30 29 28 27 26 25 24 23 22 21 20 19 18 17 16 15 14 13 12 11 10 9 8 7 6 5 4 3 2 1 0																														
ID	H G						F E						B						A												
Reset 0x00000000	0 0																														
ID	R/W	Field	Value ID	Value	Description																										
G	RW	WRITE			Write '1' to enable interrupt for event WRITE																										
			Set	1	Enable																										
			Disabled	0	Read: Disabled																										
			Enabled	1	Read: Enabled																										
H	RW	READ			Write '1' to enable interrupt for event READ																										
			Set	1	Enable																										
			Disabled	0	Read: Disabled																										
			Enabled	1	Read: Enabled																										

6.18.9.26 INTENCLR

Address offset: 0x308

Disable interrupt

Bit number	31 30 29 28 27 26 25 24 23 22 21 20 19 18 17 16 15 14 13 12 11 10 9 8 7 6 5 4 3 2 1 0																														
ID	H G						F E						B						A												
Reset 0x00000000	0 0																														
ID	R/W	Field	Value ID	Value	Description																										
A	RW	STOPPED			Write '1' to disable interrupt for event STOPPED																										
			Clear	1	Disable																										
			Disabled	0	Read: Disabled																										
			Enabled	1	Read: Enabled																										
B	RW	ERROR			Write '1' to disable interrupt for event ERROR																										
			Clear	1	Disable																										
			Disabled	0	Read: Disabled																										
			Enabled	1	Read: Enabled																										
E	RW	RXSTARTED			Write '1' to disable interrupt for event RXSTARTED																										
			Clear	1	Disable																										
			Disabled	0	Read: Disabled																										
			Enabled	1	Read: Enabled																										
F	RW	TXSTARTED			Write '1' to disable interrupt for event TXSTARTED																										
			Clear	1	Disable																										
			Disabled	0	Read: Disabled																										
			Enabled	1	Read: Enabled																										
G	RW	WRITE			Write '1' to disable interrupt for event WRITE																										
			Clear	1	Disable																										
			Disabled	0	Read: Disabled																										
			Enabled	1	Read: Enabled																										
H	RW	READ			Write '1' to disable interrupt for event READ																										
			Clear	1	Disable																										
			Disabled	0	Read: Disabled																										
			Enabled	1	Read: Enabled																										

6.18.9.27 ERRORSRC

Address offset: 0x4D0

Error source

Bit number	31 30 29 28 27 26 25 24 23 22 21 20 19 18 17 16 15 14 13 12 11 10 9 8 7 6 5 4 3 2 1 0																																
ID																															C	B	A
Reset 0x00000000	0 0																																
ID	R/W	Field	Value ID	Value	Description																												
A	RW	OVERFLOW W1C			RX buffer overflow detected, and prevented																												
			NotDetected	0	Error did not occur																												
			Detected	1	Error occurred																												
B	RW	DNACK W1C			NACK sent after receiving a data byte																												
			NotReceived	0	Error did not occur																												
			Received	1	Error occurred																												
C	RW	OVERREAD W1C			TX buffer over-read detected, and prevented																												
			NotDetected	0	Error did not occur																												
			Detected	1	Error occurred																												

6.18.9.28 MATCH

Address offset: 0x4D4

Status register indicating which address had a match

Bit number	31 30 29 28 27 26 25 24 23 22 21 20 19 18 17 16 15 14 13 12 11 10 9 8 7 6 5 4 3 2 1 0																														
ID																															A
Reset 0x00000000	0 0																														
ID	R/W	Field	Value ID	Value	Description																										
A	R	MATCH		[0..1]	Indication of which address in ADDRESS that matched the incoming address																										

6.18.9.29 ENABLE

Address offset: 0x500

Enable TWIS

Bit number	31 30 29 28 27 26 25 24 23 22 21 20 19 18 17 16 15 14 13 12 11 10 9 8 7 6 5 4 3 2 1 0																																
ID																															A	A	A
Reset 0x00000000	0 0																																
ID	R/W	Field	Value ID	Value	Description																												
A	RW	ENABLE			Enable or disable TWIS																												
			Disabled	0	Disable TWIS																												
			Enabled	9	Enable TWIS																												

6.18.9.30 PSEL.SCL

Address offset: 0x508

Pin select for SCL signal

Bit number	31	30	29	28	27	26	25	24	23	22	21	20	19	18	17	16	15	14	13	12	11	10	9	8	7	6	5	4	3	2	1	0
ID	B																															
Reset 0xFFFFFFFF	1 1																															
ID	R/W	Field	Value ID	Value	Description																											
A	RW	PIN		[0..31]	Pin number																											
B	RW	CONNECT			Connection																											
			Disconnected	1	Disconnect																											
			Connected	0	Connect																											

6.18.9.31 PSEL.SDA

Address offset: 0x50C

Pin select for SDA signal

Bit number	31	30	29	28	27	26	25	24	23	22	21	20	19	18	17	16	15	14	13	12	11	10	9	8	7	6	5	4	3	2	1	0
ID	B																															
Reset 0xFFFFFFFF	1 1																															
ID	R/W	Field	Value ID	Value	Description																											
A	RW	PIN		[0..31]	Pin number																											
B	RW	CONNECT			Connection																											
			Disconnected	1	Disconnect																											
			Connected	0	Connect																											

6.18.9.32 RXD

RXD EasyDMA channel

6.18.9.32.1 RXD.PTR

Address offset: 0x534

RXD Data pointer

Bit number	31	30	29	28	27	26	25	24	23	22	21	20	19	18	17	16	15	14	13	12	11	10	9	8	7	6	5	4	3	2	1	0
ID	A	A	A	A	A	A	A	A	A	A	A	A	A	A	A	A	A	A	A	A	A	A	A	A	A	A	A	A	A	A	A	A
Reset 0x00000000	0 0																															
ID	R/W	Field	Value ID	Value	Description																											
A	RW	PTR			RXD Data pointer																											

See the memory chapter for details about which memories are available for EasyDMA.

6.18.9.32.2 RXD.MAXCNT

Address offset: 0x538

Maximum number of bytes in RXD buffer

Bit number	31	30	29	28	27	26	25	24	23	22	21	20	19	18	17	16	15	14	13	12	11	10	9	8	7	6	5	4	3	2	1	0
ID	A																															
Reset 0x00000000	0 0																															
ID	R/W	Field	Value ID	Value	Description																											
A	RW	MAXCNT		[1..0x1FFF]	Maximum number of bytes in RXD buffer																											

6.18.9.32.3 RXD.AMOUNT

Address offset: 0x53C

Number of bytes transferred in the last RXD transaction

Bit number	31 30 29 28 27 26 25 24 23 22 21 20 19 18 17 16 15 14 13 12 11 10 9 8 7 6 5 4 3 2 1 0																														
ID	A A																														
Reset 0x00000000	0 0																														
ID	R/W	Field	Value ID	Value	Description																										
A	R	AMOUNT		[1..0x1FFF]	Number of bytes transferred in the last RXD transaction																										

6.18.9.32.4 RXD.LIST

Address offset: 0x540

EasyDMA list type

Bit number	31 30 29 28 27 26 25 24 23 22 21 20 19 18 17 16 15 14 13 12 11 10 9 8 7 6 5 4 3 2 1 0																														
ID	A A																														
Reset 0x00000000	0 0																														
ID	R/W	Field	Value ID	Value	Description																										
A	RW	LIST			List type																										
			Disabled	0	Disable EasyDMA list																										
			ArrayList	1	Use array list																										

6.18.9.33 TXD

TXD EasyDMA channel

6.18.9.33.1 TXD.PTR

Address offset: 0x544

TXD Data pointer

Bit number	31 30 29 28 27 26 25 24 23 22 21 20 19 18 17 16 15 14 13 12 11 10 9 8 7 6 5 4 3 2 1 0																														
ID	A A																														
Reset 0x00000000	0 0																														
ID	R/W	Field	Value ID	Value	Description																										
A	RW	PTR			TXD Data pointer																										

See the memory chapter for details about which memories are available for EasyDMA.

6.18.9.33.2 TXD.MAXCNT

Address offset: 0x548

Maximum number of bytes in TXD buffer

Bit number	31 30 29 28 27 26 25 24 23 22 21 20 19 18 17 16 15 14 13 12 11 10 9 8 7 6 5 4 3 2 1 0																														
ID	A A																														
Reset 0x00000000	0 0																														
ID	R/W	Field	Value ID	Value	Description																										
A	RW	MAXCNT		[1..0x1FFF]	Maximum number of bytes in TXD buffer																										

6.18.9.33.3 TXD.AMOUNT

Address offset: 0x54C

Number of bytes transferred in the last TXD transaction

Bit number	31	30	29	28	27	26	25	24	23	22	21	20	19	18	17	16	15	14	13	12	11	10	9	8	7	6	5	4	3	2	1	0																							
ID																											A	A	A	A	A	A	A	A	A	A	A	A	A	A	A	A	A	A	A	A	A	A	A	A	A	A	A	A	A
Reset 0x00000000	0																										0	0	0	0	0	0	0	0	0	0	0	0	0	0	0	0	0	0	0	0	0	0	0	0	0	0	0	0	0
ID	R/W	Field	Value ID	Value	Description																																																		
A	R	AMOUNT		[1..0x1FFF]	Number of bytes transferred in the last TXD transaction																																																		

6.18.9.33.4 TXD.LIST

Address offset: 0x550

EasyDMA list type

Bit number	31	30	29	28	27	26	25	24	23	22	21	20	19	18	17	16	15	14	13	12	11	10	9	8	7	6	5	4	3	2	1	0																							
ID																											A	A																											
Reset 0x00000000	0																										0	0	0	0	0	0	0	0	0	0	0	0	0	0	0	0	0	0	0	0	0	0	0	0	0	0	0	0	0
ID	R/W	Field	Value ID	Value	Description																																																		
A	RW	LIST			List type																																																		
			Disabled	0	Disable EasyDMA list																																																		
			ArrayList	1	Use array list																																																		

6.18.9.34 ADDRESS[n] (n=0..1)

Address offset: 0x588 + (n × 0x4)

TWI slave address n

Bit number	31	30	29	28	27	26	25	24	23	22	21	20	19	18	17	16	15	14	13	12	11	10	9	8	7	6	5	4	3	2	1	0																							
ID																											A	A	A	A	A	A																							
Reset 0x00000000	0																										0	0	0	0	0	0	0	0	0	0	0	0	0	0	0	0	0	0	0	0	0	0	0	0	0	0	0	0	0
ID	R/W	Field	Value ID	Value	Description																																																		
A	RW	ADDRESS			TWI slave address																																																		

6.18.9.35 CONFIG

Address offset: 0x594

Configuration register for the address match mechanism

Bit number	31	30	29	28	27	26	25	24	23	22	21	20	19	18	17	16	15	14	13	12	11	10	9	8	7	6	5	4	3	2	1	0																								
ID																											B	A																												
Reset 0x00000001	0																										0	0	0	0	0	0	0	0	0	0	0	0	0	0	0	0	0	0	0	0	0	0	0	0	0	0	0	0	0	1
ID	R/W	Field	Value ID	Value	Description																																																			
A-B	RW	ADDRESS[i] (i=0..1)			Enable or disable address matching on ADDRESS[i]																																																			
			Disabled	0	Disabled																																																			
			Enabled	1	Enabled																																																			

6.18.9.36 ORC

Address offset: 0x5C0

Over-read character. Character sent out in case of an over-read of the transmit buffer.

Bit number	31	30	29	28	27	26	25	24	23	22	21	20	19	18	17	16	15	14	13	12	11	10	9	8	7	6	5	4	3	2	1	0
ID	A A A A A A A A																															
Reset 0x00000000	0 0																															
ID	R/W	Field	Value ID	Value	Description																											
A	RW	ORC			Over-read character. Character sent out in case of an over-read of the transmit buffer.																											

6.18.10 Electrical specification

6.18.10.1 TWIS slave timing specifications

Symbol	Description	Min.	Typ.	Max.	Units
$f_{TWIS,SCL}$	Bit rates for TWIS ²⁰	100		400	kbps
$t_{TWIS,START}$	Time from PREPARERX/PREPARETX task to ready to receive/transmit		1.5		μ s
t_{TWIS,SU_DAT}	Data setup time before positive edge on SCL – all modes	300			ns
t_{TWIS,HD_DAT}	Data hold time after negative edge on SCL – all modes	500			ns
$t_{TWIS,HD_STA,100kbps}$	TWI slave hold time from for START condition (SDA low to SCL low), 100 kbps	5200			ns
$t_{TWIS,HD_STA,400kbps}$	TWI slave hold time from for START condition (SDA low to SCL low), 400 kbps	1300			ns
$t_{TWIS,SU_STO,100kbps}$	TWI slave setup time from SCL high to STOP condition, 100 kbps	5200			ns
$t_{TWIS,SU_STO,400kbps}$	TWI slave setup time from SCL high to STOP condition, 400 kbps	1300			ns
$t_{TWIS,BUF,100kbps}$	TWI slave bus free time between STOP and START conditions, 100 kbps		4700		ns
$t_{TWIS,BUF,400kbps}$	TWI slave bus free time between STOP and START conditions, 400 kbps		1300		ns

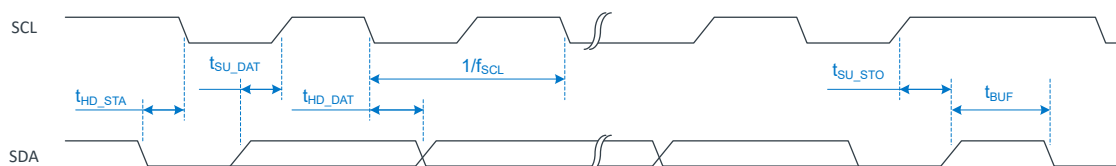

Figure 108: TWIS timing diagram, 1 byte transaction

6.19 UARTe — Universal asynchronous receiver/transmitter with EasyDMA

The Universal asynchronous receiver/transmitter with EasyDMA (UARTe) offers fast, full-duplex, asynchronous serial communication with built-in flow control (CTS, RTS) support in hardware at a rate up to 1 Mbps, and EasyDMA data transfer from/to RAM.

Listed here are the main features for UARTe:

- Full-duplex operation
- Automatic hardware flow control
- Optional even parity bit checking and generation
- EasyDMA
- Up to 1 Mbps baudrate
- Return to IDLE between transactions supported (when using HW flow control)
- One or two stop bit

²⁰ High bit rates or stronger pull-ups may require GPIOs to be set as High Drive, see GPIO chapter for more details.

- Least significant bit (LSB) first

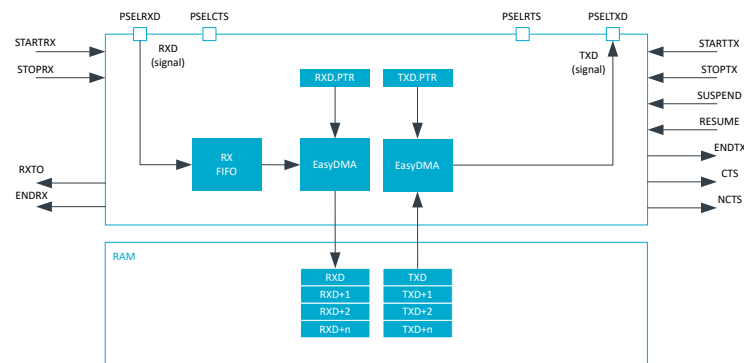

Figure 109: UARTE configuration

The GPIOs used for each UART interface can be chosen from any GPIO on the device and are independently configurable. This enables great flexibility in device pinout and efficient use of board space and signal routing.

Note: The external crystal oscillator must be enabled to obtain sufficient clock accuracy for stable communication. See [CLOCK — Clock control](#) on page 75 for more information.

6.19.1 EasyDMA

The UARTE implements EasyDMA for reading and writing to and from the RAM.

If the TXD.PTR and the RXD.PTR are not pointing to the Data RAM region, an EasyDMA transfer may result in a HardFault or RAM corruption. See [Memory](#) on page 23 for more information about the different memory regions.

The .PTR and .MAXCNT registers are double-buffered. They can be updated and prepared for the next RX/TX transmission immediately after having received the RXSTARTED/TXSTARTED event.

The ENDRX and ENDTX events indicate that the EasyDMA is finished accessing the RX or TX buffer in RAM.

6.19.2 Transmission

The first step of a DMA transmission is storing bytes in the transmit buffer and configuring EasyDMA. This is achieved by writing the initial address pointer to TXD.PTR, and the number of bytes in the RAM buffer to TXD.MAXCNT. The UARTE transmission is started by triggering the STARTTX task.

After each byte has been sent over the TXD line, a TXDRDY event will be generated.

When all bytes in the TXD buffer, as specified in the TXD.MAXCNT register, have been transmitted, the UARTE transmission will end automatically and an ENDTX event will be generated.

A UARTE transmission sequence is stopped by triggering the STOPTX task. A TXSTOPPED event will be generated when the UARTE transmitter has stopped.

If the ENDTX event has not already been generated when the UARTE transmitter has come to a stop, the UARTE will generate the ENDTX event explicitly even though all bytes in the TXD buffer, as specified in the TXD.MAXCNT register, have not been transmitted.

If flow control is enabled through the HWFC field in the CONFIG register, a transmission will be automatically suspended when CTS is deactivated and resumed when CTS is activated again, as shown in the following figure. A byte that is in transmission when CTS is deactivated will be fully transmitted before the transmission is suspended.

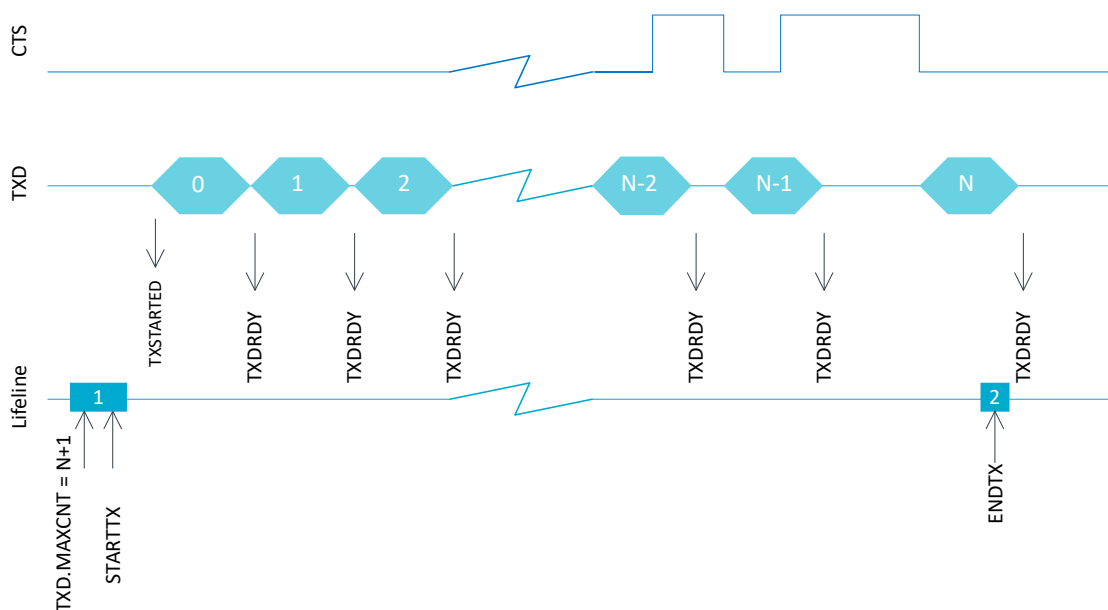

Figure 110: UART transmission

The UART transmitter will be in its lowest activity level, and consume the least amount of energy, when it is stopped, i.e. before it is started via STARTTX or after it has been stopped via STOPTH and the TXSTOPPED event has been generated. See [POWER — Power control](#) on page 69 for more information about power modes.

6.19.3 Reception

The UART receiver is started by triggering the STARTRX task. The UART receiver is using EasyDMA to store incoming data in an RX buffer in RAM.

The RX buffer is located at the address specified in the RXD.PTR register. The RXD.PTR register is double-buffered and it can be updated and prepared for the next STARTRX task immediately after the RXSTARTED event is generated. The size of the RX buffer is specified in the RXD.MAXCNT register. The UART generates an ENDRX event when it has filled up the RX buffer, as seen in the following figure.

For each byte received over the RXD line, an RXDRDY event will be generated. This event is likely to occur before the corresponding data has been transferred to Data RAM.

The RXD.AMOUNT register can be queried following an ENDRX event to see how many new bytes have been transferred to the RX buffer in RAM since the previous ENDRX event.

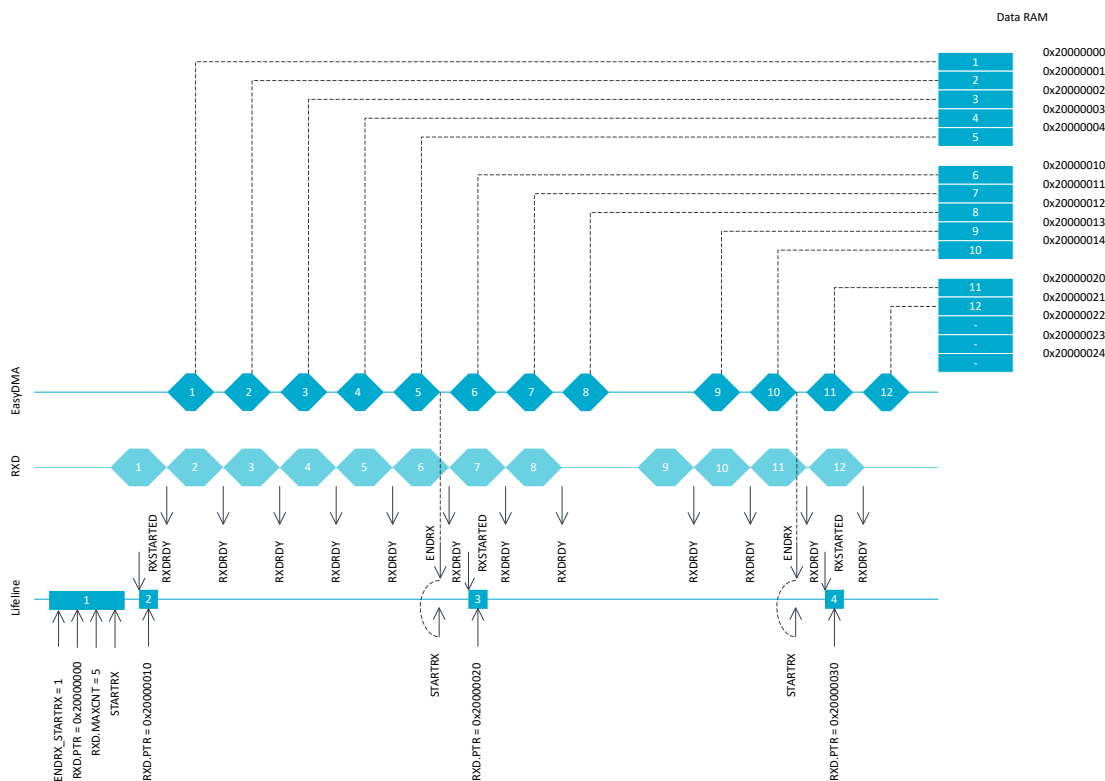

Figure 111: UARTe reception

The UARTe receiver is stopped by triggering the STOPRX task. An RXTX event is generated when the UARTe has stopped. The UARTe will make sure that an impending ENDRX event will be generated before the RXTX event is generated. This means that the UARTe will guarantee that no ENDRX event will be generated after RXTX, unless the UARTe is restarted or a FLUSHRX command is issued after the RXTX event is generated.

Note: If the ENDRX event has not been generated when the UARTe receiver stops, indicating that all pending content in the RX FIFO has been moved to the RX buffer, the UARTe will generate the ENDRX event explicitly even though the RX buffer is not full. In this scenario the ENDRX event will be generated before the RXTX event is generated.

To determine the amount of bytes the RX buffer has received, the CPU can read the RXD.AMOUNT register following the ENDRX event or the RXTX event.

The UARTe is able to receive up to four bytes after the STOPRX task has been triggered, as long as these are sent in succession immediately after the RTS signal is deactivated. After the RTS is deactivated, the UART is able to receive bytes for a period of time equal to the time needed to send four bytes on the configured baud rate.

After the RXTX event is generated the internal RX FIFO may still contain data, and to move this data to RAM the FLUSHRX task must be triggered. To make sure that this data does not overwrite data in the RX buffer, the RX buffer should be emptied or the RXD.PTR should be updated before the FLUSHRX task is triggered. To make sure that all data in the RX FIFO is moved to the RX buffer, the RXD.MAXCNT register must be set to $RXD.MAXCNT > 4$, as seen in the following figure. The UARTe will generate the ENDRX event after completing the FLUSHRX task even if the RX FIFO was empty or if the RX buffer does not get filled up. To be able to know how many bytes have actually been received into the RX buffer in this case, the CPU can read the RXD.AMOUNT register following the ENDRX event.

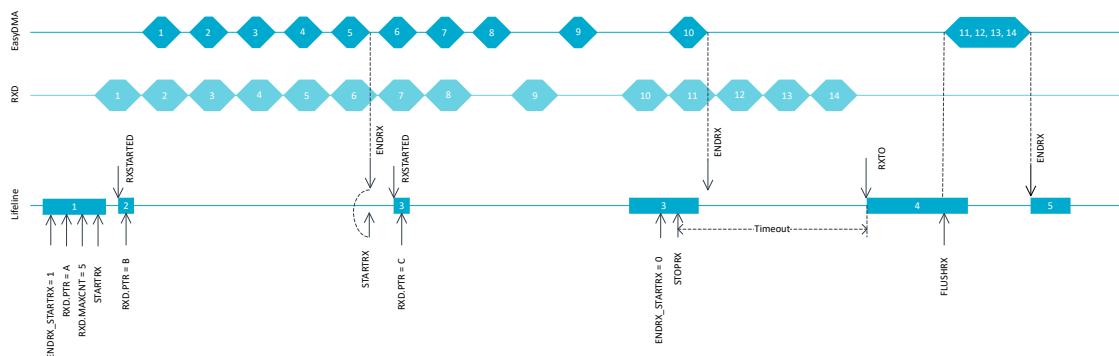

Figure 112: UARTE reception with forced stop via STOPRX

If HW flow control is enabled through the HWFC field in the CONFIG register, the RTS signal will be deactivated when the receiver is stopped via the STOPRX task or when the UARTE is only able to receive four more bytes in its internal RX FIFO.

With flow control disabled, the UARTE will function in the same way as when the flow control is enabled except that the RTS line will not be used. This means that no signal will be generated when the UARTE has reached the point where it is only able to receive four more bytes in its internal RX FIFO. Data received when the internal RX FIFO is filled up, will be lost.

The UARTE receiver will be in its lowest activity level, and consume the least amount of energy, when it is stopped, i.e. before it is started via STARTRX or after it has been stopped via STOPRX and the RXTO event has been generated. See [POWER — Power control](#) on page 69 for more information about power modes.

6.19.4 Error conditions

An ERROR event, in the form of a framing error, will be generated if a valid stop bit is not detected in a frame. Another ERROR event, in the form of a break condition, will be generated if the RXD line is held active low for longer than the length of a data frame. Effectively, a framing error is always generated before a break condition occurs.

An ERROR event will not stop reception. If the error was a parity error, the received byte will still be transferred into Data RAM, and so will following incoming bytes. If there was a framing error (wrong stop bit), that specific byte will NOT be stored into Data RAM, but following incoming bytes will.

6.19.5 Using the UARTE without flow control

If flow control is not enabled, the interface will behave as if the CTS and RTS lines are kept active all the time.

6.19.6 Parity and stop bit configuration

Automatic even parity generation for both transmission and reception can be configured using the register [CONFIG](#) on page 417. See the register description for details.

The amount of stop bits can also be configured through the register [CONFIG](#) on page 417.

6.19.7 Low power

When putting the system in low power and the peripheral is not needed, lowest possible power consumption is achieved by stopping, and then disabling the peripheral.

The STOPTH and STOPRX tasks may not be always needed (the peripheral might already be stopped), but if STOPTH and/or STOPRX is sent, software shall wait until the TXSTOPPED and/or RXTO event is received in response, before disabling the peripheral through the ENABLE register.

6.19.8 Pin configuration

The different signals RXD, CTS (Clear To Send, active low), RTS (Request To Send, active low), and TXD associated with the UARTE are mapped to physical pins according to the configuration specified in the PSEL.RXD, PSEL.CTS, PSEL.RTS, and PSEL.TXD registers respectively.

The PSEL.RXD, PSEL.CTS, PSEL.RTS, and PSEL.TXD registers and their configurations are only used as long as the UARTE is enabled, and retained only for the duration the device is in ON mode. PSEL.RXD, PSEL.RTS, PSEL.RTS, and PSEL.TXD must only be configured when the UARTE is disabled.

To secure correct signal levels on the pins by the UARTE when the system is in OFF mode, the pins must be configured in the GPIO peripheral as described in the following table.

Only one peripheral can be assigned to drive a particular GPIO pin at a time. Failing to do so may result in unpredictable behavior.

UARTE signal	UARTE pin	Direction	Output value
RXD	As specified in PSEL.RXD	Input	Not applicable
CTS	As specified in PSEL.CTS	Input	Not applicable
RTS	As specified in PSEL.RTS	Output	1
TXD	As specified in PSEL.TXD	Output	1

Table 49: GPIO configuration before enabling peripheral

6.19.9 Registers

Instances

Instance	Base address	TrustZone			Split access	Description
		Map	Att	DMA		
UARTE0 : S	0x50008000	US	NS	SA	No	Universal asynchronous receiver/transmitter with EasyDMA 0
UARTE0 : NS	0x40008000					
UARTE1 : S	0x50009000	US	NS	SA	No	Universal asynchronous receiver/transmitter with EasyDMA 1
UARTE1 : NS	0x40009000					
UARTE2 : S	0x5000A000	US	NS	SA	No	Universal asynchronous receiver/transmitter with EasyDMA 2
UARTE2 : NS	0x4000A000					
UARTE3 : S	0x5000B000	US	NS	SA	No	Universal asynchronous receiver/transmitter with EasyDMA 3
UARTE3 : NS	0x4000B000					

Register overview

Register	Offset	TZ	Description
TASKS_STARTRX	0x000		Start UART receiver
TASKS_STOPRX	0x004		Stop UART receiver
TASKS_STARTTX	0x008		Start UART transmitter
TASKS_STOPTX	0x00C		Stop UART transmitter
TASKS_FLUSHRX	0x02C		Flush RX FIFO into RX buffer
SUBSCRIBE_STARTRX	0x080		Subscribe configuration for task STARTRX
SUBSCRIBE_STOPRX	0x084		Subscribe configuration for task STOPRX
SUBSCRIBE_STARTTX	0x088		Subscribe configuration for task STARTTX
SUBSCRIBE_STOPTX	0x08C		Subscribe configuration for task STOPTX
SUBSCRIBE_FLUSHRX	0x0AC		Subscribe configuration for task FLUSHRX
EVENTS_CTS	0x100		CTS is activated (set low). Clear To Send.
EVENTS_NCTS	0x104		CTS is deactivated (set high). Not Clear To Send.

Register	Offset	TZ	Description
EVENTS_RXDRDY	0x108		Data received in RXD (but potentially not yet transferred to Data RAM)
EVENTS_ENDRX	0x110		Receive buffer is filled up
EVENTS_TXDRDY	0x11C		Data sent from TXD
EVENTS_ENDTX	0x120		Last TX byte transmitted
EVENTS_ERROR	0x124		Error detected
EVENTS_RXTO	0x144		Receiver timeout
EVENTS_RXSTARTED	0x14C		UART receiver has started
EVENTS_TXSTARTED	0x150		UART transmitter has started
EVENTS_TXSTOPPED	0x158		Transmitter stopped
PUBLISH_CTS	0x180		Publish configuration for event CTS
PUBLISH_NCTS	0x184		Publish configuration for event NCTS
PUBLISH_RXDRDY	0x188		Publish configuration for event RXDRDY
PUBLISH_ENDRX	0x190		Publish configuration for event ENDRX
PUBLISH_TXDRDY	0x19C		Publish configuration for event TXDRDY
PUBLISH_ENDTX	0x1A0		Publish configuration for event ENDTX
PUBLISH_ERROR	0x1A4		Publish configuration for event ERROR
PUBLISH_RXTO	0x1C4		Publish configuration for event RXTO
PUBLISH_RXSTARTED	0x1CC		Publish configuration for event RXSTARTED
PUBLISH_TXSTARTED	0x1D0		Publish configuration for event TXSTARTED
PUBLISH_TXSTOPPED	0x1D8		Publish configuration for event TXSTOPPED
SHORTS	0x200		Shortcuts between local events and tasks
INTEN	0x300		Enable or disable interrupt
INTENSET	0x304		Enable interrupt
INTENCLR	0x308		Disable interrupt
ERRORSRC	0x480		Error source
			This register is read/write one to clear.
ENABLE	0x500		Enable UART
PSEL.RTS	0x508		Pin select for RTS signal
PSEL.TXD	0x50C		Pin select for TXD signal
PSEL.CTS	0x510		Pin select for CTS signal
PSEL.RXD	0x514		Pin select for RXD signal
BAUDRATE	0x524		Baud rate. Accuracy depends on the HFCLK source selected.
RXD.PTR	0x534		Data pointer
RXD.MAXCNT	0x538		Maximum number of bytes in receive buffer
RXD.AMOUNT	0x53C		Number of bytes transferred in the last transaction
TXD.PTR	0x544		Data pointer
TXD.MAXCNT	0x548		Maximum number of bytes in transmit buffer
TXD.AMOUNT	0x54C		Number of bytes transferred in the last transaction
CONFIG	0x56C		Configuration of parity and hardware flow control

6.19.9.1 TASKS_STARTRX

Address offset: 0x000

Start UART receiver

Bit number	31 30 29 28 27 26 25 24 23 22 21 20 19 18 17 16 15 14 13 12 11 10 9 8 7 6 5 4 3 2 1 0																															
ID																																A
Reset 0x00000000	0 0																															0
ID	R/W	Field	Value ID	Value	Description																											
A	W	TASKS_STARTRX			Start UART receiver																											
			Trigger	1	Trigger task																											

6.19.9.2 TASKS_STOPRX

Address offset: 0x004

Stop UART receiver

Bit number	31 30 29 28 27 26 25 24 23 22 21 20 19 18 17 16 15 14 13 12 11 10 9 8 7 6 5 4 3 2 1 0																														
ID	A																														
Reset 0x00000000	0 0																														
ID	R/W	Field	Value ID	Value	Description																										
A	W	TASKS_STOPRX			Stop UART receiver																										
			Trigger	1	Trigger task																										

6.19.9.3 TASKS_STARTTX

Address offset: 0x008

Start UART transmitter

Bit number	31 30 29 28 27 26 25 24 23 22 21 20 19 18 17 16 15 14 13 12 11 10 9 8 7 6 5 4 3 2 1 0																														
ID	A																														
Reset 0x00000000	0 0																														
ID	R/W	Field	Value ID	Value	Description																										
A	W	TASKS_STARTTX			Start UART transmitter																										
			Trigger	1	Trigger task																										

6.19.9.4 TASKS_STOPTX

Address offset: 0x00C

Stop UART transmitter

Bit number	31 30 29 28 27 26 25 24 23 22 21 20 19 18 17 16 15 14 13 12 11 10 9 8 7 6 5 4 3 2 1 0																														
ID	A																														
Reset 0x00000000	0 0																														
ID	R/W	Field	Value ID	Value	Description																										
A	W	TASKS_STOPTX			Stop UART transmitter																										
			Trigger	1	Trigger task																										

6.19.9.5 TASKS_FLUSHRX

Address offset: 0x02C

Flush RX FIFO into RX buffer

Bit number	31 30 29 28 27 26 25 24 23 22 21 20 19 18 17 16 15 14 13 12 11 10 9 8 7 6 5 4 3 2 1 0																														
ID	A																														
Reset 0x00000000	0 0																														
ID	R/W	Field	Value ID	Value	Description																										
A	W	TASKS_FLUSHRX			Flush RX FIFO into RX buffer																										
			Trigger	1	Trigger task																										

6.19.9.6 SUBSCRIBE_STARTRX

Address offset: 0x080

Subscribe configuration for task **STARTRX**

Bit number	31 30 29 28 27 26 25 24 23 22 21 20 19 18 17 16 15 14 13 12 11 10 9 8 7 6 5 4 3 2 1 0																														
ID	B																								A A A A A A A						
Reset 0x00000000	0 0																														
ID	R/W	Field	Value ID	Value	Description																										
A	RW	CHIDX		[0..255]	DPPI channel that task STARTRX will subscribe to																										
B	RW	EN	Disabled	0	Disable subscription																										
			Enabled	1	Enable subscription																										

6.19.9.7 SUBSCRIBE_STOPRX

Address offset: 0x084

Subscribe configuration for task **STOPRX**

Bit number	31 30 29 28 27 26 25 24 23 22 21 20 19 18 17 16 15 14 13 12 11 10 9 8 7 6 5 4 3 2 1 0																														
ID	B																								A A A A A A A						
Reset 0x00000000	0 0																														
ID	R/W	Field	Value ID	Value	Description																										
A	RW	CHIDX		[0..255]	DPPI channel that task STOPRX will subscribe to																										
B	RW	EN	Disabled	0	Disable subscription																										
			Enabled	1	Enable subscription																										

6.19.9.8 SUBSCRIBE_STARTTX

Address offset: 0x088

Subscribe configuration for task **STARTTX**

Bit number	31 30 29 28 27 26 25 24 23 22 21 20 19 18 17 16 15 14 13 12 11 10 9 8 7 6 5 4 3 2 1 0																														
ID	B																								A A A A A A A						
Reset 0x00000000	0 0																														
ID	R/W	Field	Value ID	Value	Description																										
A	RW	CHIDX		[0..255]	DPPI channel that task STARTTX will subscribe to																										
B	RW	EN	Disabled	0	Disable subscription																										
			Enabled	1	Enable subscription																										

6.19.9.9 SUBSCRIBE_STOPTX

Address offset: 0x08C

Subscribe configuration for task **STOPTX**

Bit number	31	30	29	28	27	26	25	24	23	22	21	20	19	18	17	16	15	14	13	12	11	10	9	8	7	6	5	4	3	2	1	0
ID	B																A															
Reset	0x00000000																															
	0 0																															
ID	R/W	Field	Value ID	Value	Description																											
A	RW	CHIDX		[0..255]	DPPI channel that task <i>STOPTX</i> will subscribe to																											
B	RW	EN	Disabled	0	Disable subscription																											
			Enabled	1	Enable subscription																											

6.19.9.10 SUBSCRIBE_FLUSHRX

Address offset: 0x0AC

Subscribe configuration for task *FLUSHRX*

Bit number	31	30	29	28	27	26	25	24	23	22	21	20	19	18	17	16	15	14	13	12	11	10	9	8	7	6	5	4	3	2	1	0
ID	B																A															
Reset	0x00000000																															
	0 0																															
ID	R/W	Field	Value ID	Value	Description																											
A	RW	CHIDX		[0..255]	DPPI channel that task <i>FLUSHRX</i> will subscribe to																											
B	RW	EN	Disabled	0	Disable subscription																											
			Enabled	1	Enable subscription																											

6.19.9.11 EVENTS_CTS

Address offset: 0x100

CTS is activated (set low). Clear To Send.

Bit number	31	30	29	28	27	26	25	24	23	22	21	20	19	18	17	16	15	14	13	12	11	10	9	8	7	6	5	4	3	2	1	0
ID																																A
Reset	0x00000000																															
	0 0																															
ID	R/W	Field	Value ID	Value	Description																											
A	RW	EVENTS_CTS			CTS is activated (set low). Clear To Send.																											
			NotGenerated	0	Event not generated																											
			Generated	1	Event generated																											

6.19.9.12 EVENTS_NCTS

Address offset: 0x104

CTS is deactivated (set high). Not Clear To Send.

Bit number	31	30	29	28	27	26	25	24	23	22	21	20	19	18	17	16	15	14	13	12	11	10	9	8	7	6	5	4	3	2	1	0
ID																																A
Reset	0x00000000																															
	0 0																															
ID	R/W	Field	Value ID	Value	Description																											
A	RW	EVENTS_NCTS			CTS is deactivated (set high). Not Clear To Send.																											
			NotGenerated	0	Event not generated																											
			Generated	1	Event generated																											

6.19.9.13 EVENTS_RXDRDY

Address offset: 0x108

Data received in RXD (but potentially not yet transferred to Data RAM)

Bit number	31 30 29 28 27 26 25 24 23 22 21 20 19 18 17 16 15 14 13 12 11 10 9 8 7 6 5 4 3 2 1 0																															
ID																																A
Reset 0x00000000	0 0																															
ID	R/W	Field	Value ID	Value	Description																											
A	RW	EVENTS_RXDRDY			Data received in RXD (but potentially not yet transferred to Data RAM)																											
			NotGenerated	0	Event not generated																											
			Generated	1	Event generated																											

6.19.9.14 EVENTS_ENDRX

Address offset: 0x110

Receive buffer is filled up

Bit number	31 30 29 28 27 26 25 24 23 22 21 20 19 18 17 16 15 14 13 12 11 10 9 8 7 6 5 4 3 2 1 0																															
ID																																A
Reset 0x00000000	0 0																															
ID	R/W	Field	Value ID	Value	Description																											
A	RW	EVENTS_ENDRX			Receive buffer is filled up																											
			NotGenerated	0	Event not generated																											
			Generated	1	Event generated																											

6.19.9.15 EVENTS_TXDRDY

Address offset: 0x11C

Data sent from TXD

Bit number	31 30 29 28 27 26 25 24 23 22 21 20 19 18 17 16 15 14 13 12 11 10 9 8 7 6 5 4 3 2 1 0																															
ID																																A
Reset 0x00000000	0 0																															
ID	R/W	Field	Value ID	Value	Description																											
A	RW	EVENTS_TXDRDY			Data sent from TXD																											
			NotGenerated	0	Event not generated																											
			Generated	1	Event generated																											

6.19.9.16 EVENTS_ENDTX

Address offset: 0x120

Last TX byte transmitted

Bit number	31 30 29 28 27 26 25 24 23 22 21 20 19 18 17 16 15 14 13 12 11 10 9 8 7 6 5 4 3 2 1 0																															
ID																																A
Reset 0x00000000	0 0																															
ID	R/W	Field	Value ID	Value	Description																											
A	RW	EVENTS_ENDTX			Last TX byte transmitted																											
			NotGenerated	0	Event not generated																											
			Generated	1	Event generated																											

6.19.9.17 EVENTS_ERROR

Address offset: 0x124

Error detected

Bit number	31 30 29 28 27 26 25 24 23 22 21 20 19 18 17 16 15 14 13 12 11 10 9 8 7 6 5 4 3 2 1 0																														
ID	A																														
Reset 0x00000000	0 0																														
ID	R/W	Field	Value ID	Value	Description																										
A	RW	EVENTS_ERROR			Error detected																										
			NotGenerated	0	Event not generated																										
			Generated	1	Event generated																										

6.19.9.18 EVENTS_RXTO

Address offset: 0x144

Receiver timeout

Bit number	31 30 29 28 27 26 25 24 23 22 21 20 19 18 17 16 15 14 13 12 11 10 9 8 7 6 5 4 3 2 1 0																														
ID	A																														
Reset 0x00000000	0 0																														
ID	R/W	Field	Value ID	Value	Description																										
A	RW	EVENTS_RXTO			Receiver timeout																										
			NotGenerated	0	Event not generated																										
			Generated	1	Event generated																										

6.19.9.19 EVENTS_RXSTARTED

Address offset: 0x14C

UART receiver has started

Bit number	31 30 29 28 27 26 25 24 23 22 21 20 19 18 17 16 15 14 13 12 11 10 9 8 7 6 5 4 3 2 1 0																														
ID	A																														
Reset 0x00000000	0 0																														
ID	R/W	Field	Value ID	Value	Description																										
A	RW	EVENTS_RXSTARTED			UART receiver has started																										
			NotGenerated	0	Event not generated																										
			Generated	1	Event generated																										

6.19.9.20 EVENTS_TXSTARTED

Address offset: 0x150

UART transmitter has started

Bit number	31 30 29 28 27 26 25 24 23 22 21 20 19 18 17 16 15 14 13 12 11 10 9 8 7 6 5 4 3 2 1 0																														
ID	A																														
Reset 0x00000000	0 0																														
ID	R/W	Field	Value ID	Value	Description																										
A	RW	EVENTS_TXSTARTED			UART transmitter has started																										
			NotGenerated	0	Event not generated																										
			Generated	1	Event generated																										

6.19.9.21 EVENTS_TXSTOPPED

Address offset: 0x158

Transmitter stopped

Bit number	31 30 29 28 27 26 25 24 23 22 21 20 19 18 17 16 15 14 13 12 11 10 9 8 7 6 5 4 3 2 1 0																														
ID	A																														
Reset 0x00000000	0 0																														
ID	R/W	Field	Value ID	Value	Description																										
A	RW	EVENTS_TXSTOPPED			Transmitter stopped																										
			NotGenerated	0	Event not generated																										
			Generated	1	Event generated																										

6.19.9.22 PUBLISH_CTS

Address offset: 0x180

Publish configuration for event CTS

Bit number	31 30 29 28 27 26 25 24 23 22 21 20 19 18 17 16 15 14 13 12 11 10 9 8 7 6 5 4 3 2 1 0																														
ID	B																														
Reset 0x00000000	0 0																														
ID	R/W	Field	Value ID	Value	Description																										
A	RW	CHIDX		[0..255]	DPPI channel that event CTS will publish to																										
B	RW	EN																													
			Disabled	0	Disable publishing																										
			Enabled	1	Enable publishing																										

6.19.9.23 PUBLISH_NCTS

Address offset: 0x184

Publish configuration for event NCTS

Bit number	31 30 29 28 27 26 25 24 23 22 21 20 19 18 17 16 15 14 13 12 11 10 9 8 7 6 5 4 3 2 1 0																														
ID	B																														
Reset 0x00000000	0 0																														
ID	R/W	Field	Value ID	Value	Description																										
A	RW	CHIDX		[0..255]	DPPI channel that event NCTS will publish to																										
B	RW	EN																													
			Disabled	0	Disable publishing																										
			Enabled	1	Enable publishing																										

6.19.9.24 PUBLISH_RXDRDY

Address offset: 0x188

Publish configuration for event RXDRDY

Bit number	31 30 29 28 27 26 25 24 23 22 21 20 19 18 17 16 15 14 13 12 11 10 9 8 7 6 5 4 3 2 1 0																														
ID	B																														
Reset 0x00000000	0 0																														
ID	R/W	Field	Value ID	Value	Description																										
A	RW	CHIDX		[0..255]	DPPI channel that event RXDRDY will publish to																										
B	RW	EN																													
			Disabled	0	Disable publishing																										
			Enabled	1	Enable publishing																										

6.19.9.25 PUBLISH_ENDRX

Address offset: 0x190

Publish configuration for event [ENDRX](#)

Bit number	31 30 29 28 27 26 25 24 23 22 21 20 19 18 17 16 15 14 13 12 11 10 9 8 7 6 5 4 3 2 1 0																														
ID	B															A A A A A A A A															
Reset 0x00000000	0 0																														
ID	R/W	Field	Value ID	Value	Description																										
A	RW	CHIDX		[0..255]	DPPI channel that event ENDRX will publish to																										
B	RW	EN	Disabled	0	Disable publishing																										
			Enabled	1	Enable publishing																										

6.19.9.26 PUBLISH_TXDRDY

Address offset: 0x19C

Publish configuration for event [TXDRDY](#)

Bit number	31 30 29 28 27 26 25 24 23 22 21 20 19 18 17 16 15 14 13 12 11 10 9 8 7 6 5 4 3 2 1 0																														
ID	B															A A A A A A A A															
Reset 0x00000000	0 0																														
ID	R/W	Field	Value ID	Value	Description																										
A	RW	CHIDX		[0..255]	DPPI channel that event TXDRDY will publish to																										
B	RW	EN	Disabled	0	Disable publishing																										
			Enabled	1	Enable publishing																										

6.19.9.27 PUBLISH_ENDTX

Address offset: 0x1A0

Publish configuration for event [ENDTX](#)

Bit number	31 30 29 28 27 26 25 24 23 22 21 20 19 18 17 16 15 14 13 12 11 10 9 8 7 6 5 4 3 2 1 0																														
ID	B															A A A A A A A A															
Reset 0x00000000	0 0																														
ID	R/W	Field	Value ID	Value	Description																										
A	RW	CHIDX		[0..255]	DPPI channel that event ENDTX will publish to																										
B	RW	EN	Disabled	0	Disable publishing																										
			Enabled	1	Enable publishing																										

6.19.9.28 PUBLISH_ERROR

Address offset: 0x1A4

Publish configuration for event [ERROR](#)

Bit number	31 30 29 28 27 26 25 24 23 22 21 20 19 18 17 16 15 14 13 12 11 10 9 8 7 6 5 4 3 2 1 0																															
ID	B																								A A A A A A A A							
Reset 0x00000000	0 0																															
ID	R/W	Field	Value ID	Value	Description																											
A	RW	CHIDX		[0..255]	DPPI channel that event ERROR will publish to																											
B	RW	EN	Disabled	0	Disable publishing																											
			Enabled	1	Enable publishing																											

6.19.9.29 PUBLISH_RXTO

Address offset: 0x1C4

Publish configuration for event **RXTO**

Bit number	31 30 29 28 27 26 25 24 23 22 21 20 19 18 17 16 15 14 13 12 11 10 9 8 7 6 5 4 3 2 1 0																															
ID	B																								A A A A A A A A							
Reset 0x00000000	0 0																															
ID	R/W	Field	Value ID	Value	Description																											
A	RW	CHIDX		[0..255]	DPPI channel that event RXTO will publish to																											
B	RW	EN	Disabled	0	Disable publishing																											
			Enabled	1	Enable publishing																											

6.19.9.30 PUBLISH_RXSTARTED

Address offset: 0x1CC

Publish configuration for event **RXSTARTED**

Bit number	31 30 29 28 27 26 25 24 23 22 21 20 19 18 17 16 15 14 13 12 11 10 9 8 7 6 5 4 3 2 1 0																															
ID	B																								A A A A A A A A							
Reset 0x00000000	0 0																															
ID	R/W	Field	Value ID	Value	Description																											
A	RW	CHIDX		[0..255]	DPPI channel that event RXSTARTED will publish to																											
B	RW	EN	Disabled	0	Disable publishing																											
			Enabled	1	Enable publishing																											

6.19.9.31 PUBLISH_TXSTARTED

Address offset: 0x1D0

Publish configuration for event **TXSTARTED**

Bit number	31 30 29 28 27 26 25 24 23 22 21 20 19 18 17 16 15 14 13 12 11 10 9 8 7 6 5 4 3 2 1 0																															
ID	B																								A A A A A A A A							
Reset 0x00000000	0 0																															
ID	R/W	Field	Value ID	Value	Description																											
A	RW	CHIDX		[0..255]	DPPI channel that event TXSTARTED will publish to																											
B	RW	EN	Disabled	0	Disable publishing																											
			Enabled	1	Enable publishing																											

6.19.9.32 PUBLISH_TXSTOPPED

Address offset: 0x1D8

Publish configuration for event TXSTOPPED

Bit number	31 30 29 28 27 26 25 24 23 22 21 20 19 18 17 16 15 14 13 12 11 10 9 8 7 6 5 4 3 2 1 0																														
ID	B																												A A A A A A A A		
Reset 0x00000000	0 0																														
ID	R/W	Field	Value ID	Value	Description																										
A	RW	CHIDX		[0..255]	DPPI channel that event TXSTOPPED will publish to																										
B	RW	EN	Disabled	0	Disable publishing																										
			Enabled	1	Enable publishing																										

6.19.9.33 SHORTS

Address offset: 0x200

Shortcuts between local events and tasks

Bit number	31 30 29 28 27 26 25 24 23 22 21 20 19 18 17 16 15 14 13 12 11 10 9 8 7 6 5 4 3 2 1 0																														
ID																													D C		
Reset 0x00000000	0 0																														
ID	R/W	Field	Value ID	Value	Description																										
C	RW	ENDRX_STARTRX	Disabled	0	Shortcut between event ENDRX and task STARTRX																										
			Enabled	1	Enable shortcut																										
D	RW	ENDRX_STOPRX	Disabled	0	Shortcut between event ENDRX and task STOPRX																										
			Enabled	1	Enable shortcut																										

6.19.9.34 INTEN

Address offset: 0x300

Enable or disable interrupt

Bit number	31 30 29 28 27 26 25 24 23 22 21 20 19 18 17 16 15 14 13 12 11 10 9 8 7 6 5 4 3 2 1 0																														
ID	L J I H										G F E D										C B A										
Reset 0x00000000	0 0																														
ID	R/W	Field	Value ID	Value	Description																										
A	RW	CTS	Disabled	0	Enable or disable interrupt for event CTS																										
			Enabled	1	Disable																										
B	RW	NCTS	Disabled	0	Enable or disable interrupt for event NCTS																										
			Enabled	1	Disable																										
C	RW	RXDRDY	Disabled	0	Enable or disable interrupt for event RXDRDY																										
			Enabled	1	Disable																										
D	RW	ENDRX	Disabled	0	Enable or disable interrupt for event ENDRX																										
			Enabled	1	Disable																										
E	RW	TXDRDY			Enable or disable interrupt for event TXDRDY																										

Bit number	31 30 29 28 27 26 25 24 23 22 21 20 19 18 17 16 15 14 13 12 11 10 9 8 7 6 5 4 3 2 1 0																														
ID	L J I H																G F E D C B A														
Reset 0x00000000	0 0																														
ID	R/W	Field	Value ID	Value	Description																										
			Disabled	0	Disable																										
			Enabled	1	Enable																										
F	RW	ENDTX			Enable or disable interrupt for event ENDTX																										
			Disabled	0	Disable																										
			Enabled	1	Enable																										
G	RW	ERROR			Enable or disable interrupt for event ERROR																										
			Disabled	0	Disable																										
			Enabled	1	Enable																										
H	RW	RXTO			Enable or disable interrupt for event RXTO																										
			Disabled	0	Disable																										
			Enabled	1	Enable																										
I	RW	RXSTARTED			Enable or disable interrupt for event RXSTARTED																										
			Disabled	0	Disable																										
			Enabled	1	Enable																										
J	RW	TXSTARTED			Enable or disable interrupt for event TXSTARTED																										
			Disabled	0	Disable																										
			Enabled	1	Enable																										
L	RW	TXSTOPPED			Enable or disable interrupt for event TXSTOPPED																										
			Disabled	0	Disable																										
			Enabled	1	Enable																										

6.19.9.35 INTENSET

Address offset: 0x304

Enable interrupt

Bit number	31 30 29 28 27 26 25 24 23 22 21 20 19 18 17 16 15 14 13 12 11 10 9 8 7 6 5 4 3 2 1 0																														
ID	L J I H																G F E D C B A														
Reset 0x00000000	0 0																														
ID	R/W	Field	Value ID	Value	Description																										
A	RW	CTS			Write '1' to enable interrupt for event CTS																										
			Set	1	Enable																										
			Disabled	0	Read: Disabled																										
			Enabled	1	Read: Enabled																										
B	RW	NCTS			Write '1' to enable interrupt for event NCTS																										
			Set	1	Enable																										
			Disabled	0	Read: Disabled																										
			Enabled	1	Read: Enabled																										
C	RW	RXDRDY			Write '1' to enable interrupt for event RXDRDY																										
			Set	1	Enable																										
			Disabled	0	Read: Disabled																										
			Enabled	1	Read: Enabled																										
D	RW	ENDRX			Write '1' to enable interrupt for event ENDRX																										
			Set	1	Enable																										
			Disabled	0	Read: Disabled																										
			Enabled	1	Read: Enabled																										
E	RW	TXDRDY			Write '1' to enable interrupt for event TXDRDY																										
			Set	1	Enable																										
			Disabled	0	Read: Disabled																										

Bit number	31 30 29 28 27 26 25 24 23 22 21 20 19 18 17 16 15 14 13 12 11 10 9 8 7 6 5 4 3 2 1 0																															
ID	L J I H															G F E D C B A																
Reset 0x00000000		0 0																														
ID	R/W	Field	Value ID	Value	Description																											
			Enabled	1	Read: Enabled																											
F	RW	ENDTX			Write '1' to enable interrupt for event ENDTX																											
			Set	1	Enable																											
			Disabled	0	Read: Disabled																											
			Enabled	1	Read: Enabled																											
G	RW	ERROR			Write '1' to enable interrupt for event ERROR																											
			Set	1	Enable																											
			Disabled	0	Read: Disabled																											
			Enabled	1	Read: Enabled																											
H	RW	RXTO			Write '1' to enable interrupt for event RXTO																											
			Set	1	Enable																											
			Disabled	0	Read: Disabled																											
			Enabled	1	Read: Enabled																											
I	RW	RXSTARTED			Write '1' to enable interrupt for event RXSTARTED																											
			Set	1	Enable																											
			Disabled	0	Read: Disabled																											
			Enabled	1	Read: Enabled																											
J	RW	TXSTARTED			Write '1' to enable interrupt for event TXSTARTED																											
			Set	1	Enable																											
			Disabled	0	Read: Disabled																											
			Enabled	1	Read: Enabled																											
L	RW	TXSTOPPED			Write '1' to enable interrupt for event TXSTOPPED																											
			Set	1	Enable																											
			Disabled	0	Read: Disabled																											
			Enabled	1	Read: Enabled																											

6.19.9.36 INTENCLR

Address offset: 0x308

Disable interrupt

Bit number	31 30 29 28 27 26 25 24 23 22 21 20 19 18 17 16 15 14 13 12 11 10 9 8 7 6 5 4 3 2 1 0																															
ID	L J I H															G F E D C B A																
Reset 0x00000000		0 0																														
ID	R/W	Field	Value ID	Value	Description																											
A	RW	CTS			Write '1' to disable interrupt for event CTS																											
			Clear	1	Disable																											
			Disabled	0	Read: Disabled																											
			Enabled	1	Read: Enabled																											
B	RW	NCTS			Write '1' to disable interrupt for event NCTS																											
			Clear	1	Disable																											
			Disabled	0	Read: Disabled																											
			Enabled	1	Read: Enabled																											
C	RW	RXDRDY			Write '1' to disable interrupt for event RXDRDY																											
			Clear	1	Disable																											
			Disabled	0	Read: Disabled																											
			Enabled	1	Read: Enabled																											
D	RW	ENDRX			Write '1' to disable interrupt for event ENDRX																											
			Clear	1	Disable																											

Bit number		31 30 29 28 27 26 25 24 23 22 21 20 19 18 17 16 15 14 13 12 11 10 9 8 7 6 5 4 3 2 1 0																														
ID		L J I H																G F E D C B A														
Reset 0x00000000		0 0																														
ID	R/W	Field	Value ID	Value	Description																											
			Disabled	0	Read: Disabled																											
			Enabled	1	Read: Enabled																											
			E RW TXDRDY				Write '1' to disable interrupt for event TXDRDY																									
			Clear	1	Disable																											
			Disabled	0	Read: Disabled																											
			Enabled	1	Read: Enabled																											
			F RW ENDTX				Write '1' to disable interrupt for event ENDTX																									
			Clear	1	Disable																											
			Disabled	0	Read: Disabled																											
			Enabled	1	Read: Enabled																											
			G RW ERROR				Write '1' to disable interrupt for event ERROR																									
			Clear	1	Disable																											
			Disabled	0	Read: Disabled																											
			Enabled	1	Read: Enabled																											
			H RW RXTO				Write '1' to disable interrupt for event RXTO																									
			Clear	1	Disable																											
			Disabled	0	Read: Disabled																											
			Enabled	1	Read: Enabled																											
			I RW RXSTARTED				Write '1' to disable interrupt for event RXSTARTED																									
			Clear	1	Disable																											
			Disabled	0	Read: Disabled																											
			Enabled	1	Read: Enabled																											
			J RW TXSTARTED				Write '1' to disable interrupt for event TXSTARTED																									
			Clear	1	Disable																											
			Disabled	0	Read: Disabled																											
			Enabled	1	Read: Enabled																											
			L RW TXSTOPPED				Write '1' to disable interrupt for event TXSTOPPED																									
			Clear	1	Disable																											
			Disabled	0	Read: Disabled																											
			Enabled	1	Read: Enabled																											

6.19.9.37 ERRORSRC

Address offset: 0x480

Error source

This register is read/write one to clear.

Bit number		31 30 29 28 27 26 25 24 23 22 21 20 19 18 17 16 15 14 13 12 11 10 9 8 7 6 5 4 3 2 1 0																														
ID																		D C B A														
Reset 0x00000000		0 0																														
ID	R/W	Field	Value ID	Value	Description																											
A	RW	OVERRUN W1C			Overflow error																											
					A start bit is received while the previous data still lies in RXD. (Previous data is lost.)																											
			NotPresent	0	Read: error not present																											
			Present	1	Read: error present																											
B	RW	PARITY W1C			Parity error																											
					A character with bad parity is received, if HW parity check is enabled.																											

Bit number	31 30 29 28 27 26 25 24 23 22 21 20 19 18 17 16 15 14 13 12 11 10 9 8 7 6 5 4 3 2 1 0																																	
ID																															D	C	B	A
Reset 0x00000000	0 0																																	
ID	R/W	Field	Value ID	Value	Description																													
			NotPresent	0	Read: error not present																													
			Present	1	Read: error present																													
C	RW	FRAMING			Framing error occurred																													
		W1C			A valid stop bit is not detected on the serial data input after all bits in a character have been received.																													
			NotPresent	0	Read: error not present																													
			Present	1	Read: error present																													
D	RW	BREAK			Break condition																													
		W1C			The serial data input is '0' for longer than the length of a data frame. (The data frame length is 10 bits without parity bit, and 11 bits with parity bit).																													
			NotPresent	0	Read: error not present																													
			Present	1	Read: error present																													

6.19.9.38 ENABLE

Address offset: 0x500

Enable UART

Bit number	31 30 29 28 27 26 25 24 23 22 21 20 19 18 17 16 15 14 13 12 11 10 9 8 7 6 5 4 3 2 1 0																																	
ID																															A	A	A	A
Reset 0x00000000	0 0																																	
ID	R/W	Field	Value ID	Value	Description																													
A	RW	ENABLE			Enable or disable UARTE																													
			Disabled	0	Disable UARTE																													
			Enabled	8	Enable UARTE																													

6.19.9.39 PSEL.RTS

Address offset: 0x508

Pin select for RTS signal

Bit number	31 30 29 28 27 26 25 24 23 22 21 20 19 18 17 16 15 14 13 12 11 10 9 8 7 6 5 4 3 2 1 0																																		
ID	B																														A	A	A	A	A
Reset 0xFFFFFFFF	1 1																																		
ID	R/W	Field	Value ID	Value	Description																														
A	RW	PIN		[0..31]	Pin number																														
B	RW	CONNECT			Connection																														
			Disconnected	1	Disconnect																														
			Connected	0	Connect																														

6.19.9.40 PSEL.TXD

Address offset: 0x50C

Pin select for TXD signal

Bit number	31 30 29 28 27 26 25 24 23 22 21 20 19 18 17 16 15 14 13 12 11 10 9 8 7 6 5 4 3 2 1 0																														
ID	B																											A A A A A			
Reset 0xFFFFFFFF	1 1																														
ID	R/W	Field	Value ID	Value	Description																										
A	RW	PIN		[0..31]	Pin number																										
B	RW	CONNECT			Connection																										
			Disconnected	1	Disconnect																										
			Connected	0	Connect																										

6.19.9.41 PSEL.CTS

Address offset: 0x510

Pin select for CTS signal

Bit number	31 30 29 28 27 26 25 24 23 22 21 20 19 18 17 16 15 14 13 12 11 10 9 8 7 6 5 4 3 2 1 0																														
ID	B																											A A A A A			
Reset 0xFFFFFFFF	1 1																														
ID	R/W	Field	Value ID	Value	Description																										
A	RW	PIN		[0..31]	Pin number																										
B	RW	CONNECT			Connection																										
			Disconnected	1	Disconnect																										
			Connected	0	Connect																										

6.19.9.42 PSEL.RXD

Address offset: 0x514

Pin select for RXD signal

Bit number	31 30 29 28 27 26 25 24 23 22 21 20 19 18 17 16 15 14 13 12 11 10 9 8 7 6 5 4 3 2 1 0																														
ID	B																											A A A A A			
Reset 0xFFFFFFFF	1 1																														
ID	R/W	Field	Value ID	Value	Description																										
A	RW	PIN		[0..31]	Pin number																										
B	RW	CONNECT			Connection																										
			Disconnected	1	Disconnect																										
			Connected	0	Connect																										

6.19.9.43 BAUDRATE

Address offset: 0x524

Baud rate. Accuracy depends on the HFCLK source selected.

Bit number	31 30 29 28 27 26 25 24 23 22 21 20 19 18 17 16 15 14 13 12 11 10 9 8 7 6 5 4 3 2 1 0																														
ID	A A																														
Reset 0x04000000	0 0 0 0 0 1 0																														
ID	R/W	Field	Value ID	Value	Description																										
A	RW	BAUDRATE			Baud rate																										
			Baud1200	0x0004F000	1200 baud (actual rate: 1205)																										
			Baud2400	0x0009D000	2400 baud (actual rate: 2396)																										
			Baud4800	0x0013B000	4800 baud (actual rate: 4808)																										
			Baud9600	0x00275000	9600 baud (actual rate: 9598)																										
			Baud14400	0x003AF000	14400 baud (actual rate: 14401)																										

Bit number	31	30	29	28	27	26	25	24	23	22	21	20	19	18	17	16	15	14	13	12	11	10	9	8	7	6	5	4	3	2	1	0
ID	A	A	A	A	A	A	A	A	A	A	A	A	A	A	A	A	A	A	A	A	A	A	A	A	A	A	A	A	A	A	A	A
Reset 0x04000000	0	0	0	0	0	0	1	0	0	0	0	0	0	0	0	0	0	0	0	0	0	0	0	0	0	0	0	0	0	0	0	
ID	R/W	Field	Value ID	Value	Description																											
			Baud19200	0x004EA000	19200 baud (actual rate: 19208)																											
			Baud28800	0x0075C000	28800 baud (actual rate: 28777)																											
			Baud31250	0x00800000	31250 baud																											
			Baud38400	0x009D0000	38400 baud (actual rate: 38369)																											
			Baud56000	0x00E50000	56000 baud (actual rate: 55944)																											
			Baud57600	0x00EB0000	57600 baud (actual rate: 57554)																											
			Baud76800	0x013A9000	76800 baud (actual rate: 76923)																											
			Baud115200	0x01D60000	115200 baud (actual rate: 115108)																											
			Baud230400	0x03B00000	230400 baud (actual rate: 231884)																											
			Baud250000	0x04000000	250000 baud																											
			Baud460800	0x07400000	460800 baud (actual rate: 457143)																											
			Baud921600	0x0F000000	921600 baud (actual rate: 941176)																											
			Baud1M	0x10000000	1 megabaud																											

6.19.9.44 RXD

RXD EasyDMA channel

6.19.9.44.1 RXD.PTR

Address offset: 0x534

Data pointer

Bit number	31	30	29	28	27	26	25	24	23	22	21	20	19	18	17	16	15	14	13	12	11	10	9	8	7	6	5	4	3	2	1	0
ID	A	A	A	A	A	A	A	A	A	A	A	A	A	A	A	A	A	A	A	A	A	A	A	A	A	A	A	A	A	A	A	
Reset 0x00000000	0	0	0	0	0	0	0	0	0	0	0	0	0	0	0	0	0	0	0	0	0	0	0	0	0	0	0	0	0	0	0	
ID	R/W	Field	Value ID	Value	Description																											
A	RW	PTR			Data pointer																											

See the memory chapter for details about which memories are available for EasyDMA.

6.19.9.44.2 RXD.MAXCNT

Address offset: 0x538

Maximum number of bytes in receive buffer

Bit number	31	30	29	28	27	26	25	24	23	22	21	20	19	18	17	16	15	14	13	12	11	10	9	8	7	6	5	4	3	2	1	0
ID																								A	A	A	A	A	A	A	A	
Reset 0x00000000	0	0	0	0	0	0	0	0	0	0	0	0	0	0	0	0	0	0	0	0	0	0	0	0	0	0	0	0	0	0	0	
ID	R/W	Field	Value ID	Value	Description																											
A	RW	MAXCNT		[1..0x1FFF]	Maximum number of bytes in receive buffer																											

6.19.9.44.3 RXD.AMOUNT

Address offset: 0x53C

Number of bytes transferred in the last transaction

Bit number	31	30	29	28	27	26	25	24	23	22	21	20	19	18	17	16	15	14	13	12	11	10	9	8	7	6	5	4	3	2	1	0																						
ID																								A	A	A	A	A	A	A	A	A	A	A	A	A	A	A	A	A	A	A	A	A	A	A	A	A	A	A	A	A	A	A
Reset	0x00000000																																																					
	0	0	0	0	0	0	0	0	0	0	0	0	0	0	0	0	0	0	0	0	0	0	0	0	0	0	0	0	0	0	0	0	0	0	0																			
ID	R/W	Field	Value ID	Value	Description																																																	
A	R	AMOUNT		[1..0x1FFF]	Number of bytes transferred in the last transaction																																																	

6.19.9.45 TXD

TXD EasyDMA channel

6.19.9.45.1 TXD.PTR

Address offset: 0x544

Data pointer

Bit number	31	30	29	28	27	26	25	24	23	22	21	20	19	18	17	16	15	14	13	12	11	10	9	8	7	6	5	4	3	2	1	0		
ID	A	A	A	A	A	A	A	A	A	A	A	A	A	A	A	A	A	A	A	A	A	A	A	A	A	A	A	A	A	A	A	A	A	
Reset	0x00000000																																	
	0	0	0	0	0	0	0	0	0	0	0	0	0	0	0	0	0	0	0	0	0	0	0	0	0	0	0	0	0	0	0	0	0	0
ID	R/W	Field	Value ID	Value	Description																													
A	RW	PTR			Data pointer																													

See the memory chapter for details about which memories are available for EasyDMA.

6.19.9.45.2 TXD.MAXCNT

Address offset: 0x548

Maximum number of bytes in transmit buffer

Bit number	31	30	29	28	27	26	25	24	23	22	21	20	19	18	17	16	15	14	13	12	11	10	9	8	7	6	5	4	3	2	1	0																					
ID																								A	A	A	A	A	A	A	A	A	A	A	A	A	A	A	A	A	A	A	A	A	A	A	A	A	A	A	A	A	A
Reset	0x00000000																																																				
	0	0	0	0	0	0	0	0	0	0	0	0	0	0	0	0	0	0	0	0	0	0	0	0	0	0	0	0	0	0	0	0	0	0																			
ID	R/W	Field	Value ID	Value	Description																																																
A	RW	MAXCNT		[1..0x1FFF]	Maximum number of bytes in transmit buffer																																																

6.19.9.45.3 TXD.AMOUNT

Address offset: 0x54C

Number of bytes transferred in the last transaction

Bit number	31	30	29	28	27	26	25	24	23	22	21	20	19	18	17	16	15	14	13	12	11	10	9	8	7	6	5	4	3	2	1	0																					
ID																								A	A	A	A	A	A	A	A	A	A	A	A	A	A	A	A	A	A	A	A	A	A	A	A	A	A	A	A	A	A
Reset	0x00000000																																																				
	0	0	0	0	0	0	0	0	0	0	0	0	0	0	0	0	0	0	0	0	0	0	0	0	0	0	0	0	0	0	0	0	0	0																			
ID	R/W	Field	Value ID	Value	Description																																																
A	R	AMOUNT		[1..0x1FFF]	Number of bytes transferred in the last transaction																																																

6.19.9.46 CONFIG

Address offset: 0x56C

Configuration of parity and hardware flow control

Bit number	31 30 29 28 27 26 25 24 23 22 21 20 19 18 17 16 15 14 13 12 11 10 9 8 7 6 5 4 3 2 1 0																																	
ID																															C	B	B	B
Reset	0x00000000																																	
0	0	0	0	0	0	0	0	0	0	0	0	0	0	0	0	0	0	0	0	0	0	0	0	0	0	0	0	0	0	0	0	0		
ID	R/W	Field	Value ID	Value	Description																													
	RW	HWFC			Hardware flow control																													
			Disabled	0	Disabled																													
			Enabled	1	Enabled																													
B	RW	PARITY			Parity																													
			Excluded	0x0	Exclude parity bit																													
			Included	0x7	Include even parity bit																													
C	RW	STOP			Stop bits																													
			One	0	One stop bit																													
			Two	1	Two stop bits																													

6.19.10 Electrical specification

6.19.10.1 UARTe electrical specification

Symbol	Description	Min.	Typ.	Max.	Units
f_{UARTE}	Baud rate for UARTE ²¹ .			1000	kbps
$t_{\text{UARTE,CTSH}}$	CTS high time	1			μs
$t_{\text{UARTE,START}}$	Time from STARTRX/STARTTX task to transmission started		0.25		μs

6.20 WDT — Watchdog timer

A countdown watchdog timer using the low-frequency clock source (LFCLK) offers configurable and robust protection against application lock-up.

The watchdog timer is started by triggering the START task.

The watchdog can be paused during long CPU sleep periods for low power applications and when the debugger has halted the CPU. The watchdog is implemented as a down-counter that generates a TIMEOUT event when it wraps over after counting down to 0. When the watchdog timer is started through the START task, the watchdog counter is loaded with the value specified in the CRV register. This counter is also reloaded with the value specified in the CRV register when a reload request is granted.

The watchdog's timeout period is given by:

$$\text{timeout [s]} = (\text{CRV} + 1) / 32768$$

When started, the watchdog will automatically force the 32.768 kHz RC oscillator on as long as no other 32.768 kHz clock source is running and generating the 32.768 kHz system clock, see chapter [CLOCK — Clock control](#) on page 75.

6.20.1 Reload criteria

The watchdog has eight separate reload request registers, which shall be used to request the watchdog to reload its counter with the value specified in the CRV register. To reload the watchdog counter, the special value 0x6E524635 needs to be written to all enabled reload registers.

One or more RR registers can be individually enabled through the RREN register.

²¹ High baud rates may require GPIOs to be set as High Drive, see GPIO chapter for more details.

6.20.2 Temporarily pausing the watchdog

By default, the watchdog will be active counting down the down-counter while the CPU is sleeping and when it is halted by the debugger. It is however possible to configure the watchdog to automatically pause while the CPU is sleeping as well as when it is halted by the debugger.

6.20.3 Watchdog reset

A TIMEOUT event will automatically lead to a watchdog reset.

See [Reset](#) on page 61 for more information about reset sources. If the watchdog is configured to generate an interrupt on the TIMEOUT event, the watchdog reset will be postponed with two 32.768 kHz clock cycles after the TIMEOUT event has been generated. Once the TIMEOUT event has been generated, the impending watchdog reset will always be effectuated.

The watchdog must be configured before it is started. After it is started, the watchdog's configuration registers, which comprise registers CRV, RREN, and CONFIG, will be blocked for further configuration.

The watchdog can be reset from several reset sources, see [Reset behavior](#) on page 62.

When the device starts running again, after a reset, or waking up from OFF mode, the watchdog configuration registers will be available for configuration again.

6.20.4 Registers

Instances

Instance	Base address	TrustZone			Split access	Description
		Map	Att	DMA		
WDT : S	0x50018000					
WDT : NS	0x40018000	US	NS	NA	No	Watchdog timer

Register overview

Register	Offset	TZ	Description
TASKS_START	0x000		Start the watchdog
SUBSCRIBE_START	0x080		Subscribe configuration for task START
EVENTS_TIMEOUT	0x100		Watchdog timeout
PUBLISH_TIMEOUT	0x180		Publish configuration for event TIMEOUT
INTENSET	0x304		Enable interrupt
INTENCLR	0x308		Disable interrupt
RUNSTATUS	0x400		Run status
REQSTATUS	0x404		Request status
CRV	0x504		Counter reload value
RREN	0x508		Enable register for reload request registers
CONFIG	0x50C		Configuration register
RR[n]	0x600		Reload request n

6.20.4.1 TASKS_START

Address offset: 0x000

Start the watchdog

Bit number	31	30	29	28	27	26	25	24	23	22	21	20	19	18	17	16	15	14	13	12	11	10	9	8	7	6	5	4	3	2	1	0
ID	A																															
Reset 0x00000000	0 0																															
ID	R/W	Field	Value ID	Value	Description																											
A	W	TASKS_START			Start the watchdog																											
			Trigger	1	Trigger task																											

6.20.4.2 SUBSCRIBE_START

Address offset: 0x080

Subscribe configuration for task **START**

Bit number	31	30	29	28	27	26	25	24	23	22	21	20	19	18	17	16	15	14	13	12	11	10	9	8	7	6	5	4	3	2	1	0																									
ID	B																											A				A	A	A	A	A	A	A	A	A	A	A	A	A	A	A	A	A	A	A	A	A	A	A	A	A	A
Reset 0x00000000	0 0																																																								
ID	R/W	Field	Value ID	Value	Description																																																				
A	RW	CHIDX		[0..255]	DPPI channel that task START will subscribe to																																																				
B	RW	EN																																																							
			Disabled	0	Disable subscription																																																				
			Enabled	1	Enable subscription																																																				

6.20.4.3 EVENTS_TIMEOUT

Address offset: 0x100

Watchdog timeout

Bit number	31	30	29	28	27	26	25	24	23	22	21	20	19	18	17	16	15	14	13	12	11	10	9	8	7	6	5	4	3	2	1	0
ID	A																															
Reset 0x00000000	0 0																															
ID	R/W	Field	Value ID	Value	Description																											
A	RW	EVENTS_TIMEOUT			Watchdog timeout																											
			NotGenerated	0	Event not generated																											
			Generated	1	Event generated																											

6.20.4.4 PUBLISH_TIMEOUT

Address offset: 0x180

Publish configuration for event **TIMEOUT**

Bit number	31	30	29	28	27	26	25	24	23	22	21	20	19	18	17	16	15	14	13	12	11	10	9	8	7	6	5	4	3	2	1	0																								
ID	B																											A				A	A	A	A	A	A	A	A	A	A	A	A	A	A	A	A	A	A	A	A	A	A	A	A	A
Reset 0x00000000	0 0																																																							
ID	R/W	Field	Value ID	Value	Description																																																			
A	RW	CHIDX		[0..255]	DPPI channel that event TIMEOUT will publish to																																																			
B	RW	EN																																																						
			Disabled	0	Disable publishing																																																			
			Enabled	1	Enable publishing																																																			

6.20.4.5 INTENSET

Address offset: 0x304

Enable interrupt

Bit number	31	30	29	28	27	26	25	24	23	22	21	20	19	18	17	16	15	14	13	12	11	10	9	8	7	6	5	4	3	2	1	0
ID																																A
Reset	0x00000000																															
Reset	0 0																															
ID	R/W	Field	Value ID	Value	Description																											
A	RW	TIMEOUT			Write '1' to enable interrupt for event TIMEOUT																											
			Set	1	Enable																											
			Disabled	0	Read: Disabled																											
			Enabled	1	Read: Enabled																											

6.20.4.6 INTENCLR

Address offset: 0x308

Disable interrupt

Bit number	31	30	29	28	27	26	25	24	23	22	21	20	19	18	17	16	15	14	13	12	11	10	9	8	7	6	5	4	3	2	1	0
ID																																A
Reset	0x00000000																															
Reset	0 0																															
ID	R/W	Field	Value ID	Value	Description																											
A	RW	TIMEOUT			Write '1' to disable interrupt for event TIMEOUT																											
			Clear	1	Disable																											
			Disabled	0	Read: Disabled																											
			Enabled	1	Read: Enabled																											

6.20.4.7 RUNSTATUS

Address offset: 0x400

Run status

Bit number	31	30	29	28	27	26	25	24	23	22	21	20	19	18	17	16	15	14	13	12	11	10	9	8	7	6	5	4	3	2	1	0
ID																																
Reset	0x00000000																															
Reset	0 0																															
ID	R/W	Field	Value ID	Value	Description																											
	R	RUNSTATUSWDT			Indicates whether or not the watchdog is running																											
			NotRunning	0	Watchdog not running																											
			Running	1	Watchdog is running																											

6.20.4.8 REQSTATUS

Address offset: 0x404

Request status

Bit number	31	30	29	28	27	26	25	24	23	22	21	20	19	18	17	16	15	14	13	12	11	10	9	8	7	6	5	4	3	2	1	0			
ID																												H	G	F	E	D	C	B	A
Reset	0x00000001																																		
Reset	0 1																																		
ID	R/W	Field	Value ID	Value	Description																														
A-H	R	RR[i] (i=0..7)			Request status for RR[i] register																														
			DisabledOrRequested0		RR[i] register is not enabled, or are already requesting reload																														
			EnabledAndUnrequested		RR[i] register is enabled, and are not yet requesting reload																														

6.20.4.9 CRV

Address offset: 0x504

Counter reload value

Bit number	31	30	29	28	27	26	25	24	23	22	21	20	19	18	17	16	15	14	13	12	11	10	9	8	7	6	5	4	3	2	1	0
ID	A	A	A	A	A	A	A	A	A	A	A	A	A	A	A	A	A	A	A	A	A	A	A	A	A	A	A	A	A	A	A	A
Reset 0xFFFFFFFF	1	1	1	1	1	1	1	1	1	1	1	1	1	1	1	1	1	1	1	1	1	1	1	1	1	1	1	1	1	1	1	
ID	R/W	Field	Value ID	Value	Description																											
A	RW	CRV		[0x0000000F..0xFFFFFFFF]	Counter reload value in number of cycles of the 32.768 kHz clock																											

6.20.4.10 RREN

Address offset: 0x508

Enable register for reload request registers

Bit number	31	30	29	28	27	26	25	24	23	22	21	20	19	18	17	16	15	14	13	12	11	10	9	8	7	6	5	4	3	2	1	0	
ID																										H	G	F	E	D	C	B	A
Reset 0x00000001	0	0	0	0	0	0	0	0	0	0	0	0	0	0	0	0	0	0	0	0	0	0	0	0	0	0	0	0	0	0	0	1	
ID	R/W	Field	Value ID	Value	Description																												
A-H	RW	RR[i] (i=0..7)			Enable or disable RR[i] register																												
			Disabled	0	Disable RR[i] register																												
			Enabled	1	Enable RR[i] register																												

6.20.4.11 CONFIG

Address offset: 0x50C

Configuration register

Bit number	31	30	29	28	27	26	25	24	23	22	21	20	19	18	17	16	15	14	13	12	11	10	9	8	7	6	5	4	3	2	1	0
ID																																C
Reset 0x00000001	0	0	0	0	0	0	0	0	0	0	0	0	0	0	0	0	0	0	0	0	0	0	0	0	0	0	0	0	0	0	1	
ID	R/W	Field	Value ID	Value	Description																											
	RW	SLEEP			Configure the watchdog to either be paused, or kept running, while the CPU is sleeping																											
			Pause	0	Pause watchdog while the CPU is sleeping																											
			Run	1	Keep the watchdog running while the CPU is sleeping																											
C	RW	HALT			Configure the watchdog to either be paused, or kept running, while the CPU is halted by the debugger																											
			Pause	0	Pause watchdog while the CPU is halted by the debugger																											
			Run	1	Keep the watchdog running while the CPU is halted by the debugger																											

6.20.4.12 RR[n] (n=0..7)

Address offset: 0x600 + (n × 0x4)

Reload request n

Bit number	31	30	29	28	27	26	25	24	23	22	21	20	19	18	17	16	15	14	13	12	11	10	9	8	7	6	5	4	3	2	1	0
ID	A	A	A	A	A	A	A	A	A	A	A	A	A	A	A	A	A	A	A	A	A	A	A	A	A	A	A	A	A	A	A	
Reset 0x00000000	0	0	0	0	0	0	0	0	0	0	0	0	0	0	0	0	0	0	0	0	0	0	0	0	0	0	0	0	0	0	0	
ID	R/W	Field	Value ID	Value	Description																											
A	W	RR			Reload request register																											
			Reload	0x6E524635	Value to request a reload of the watchdog timer																											

6.20.5 Electrical specification

6.20.5.1 Watchdog Timer Electrical Specification

Symbol	Description	Min.	Typ.	Max.	Units
t_{WDT}	Time out interval	31 μ s		36 h	

7 LTE modem

The long term evolution (LTE) modem consists of baseband processing and RF components, which together implement a complete 3GPP LTE release 13 (Rel-13) Cat-M1 and Cat-NB1 and LTE release 14 (Rel-14) Cat-NB1 and Cat-NB2 capable product.

Note: The LTE modem hardware supports Cat-NB2, but needs modem firmware support to get enabled. For information on Cat-NB2 feature support, see the *nRF9160 Modem Firmware Release Notes* included in the latest *nRF9160 modem firmware*.

As shown in the following figure, the parts of the LTE modem are:

- RF transceiver
- Modem baseband (BB)
- Embedded flash/RAM
- Modem host processor and peripherals

The modem baseband and host processor provide functions for the LTE L1, L2, and L3 (layers 1, 2, and 3 respectively) as well as IP communication layers. Modem peripherals provide hardware services for the modem operating system and the modem secure execution environment.

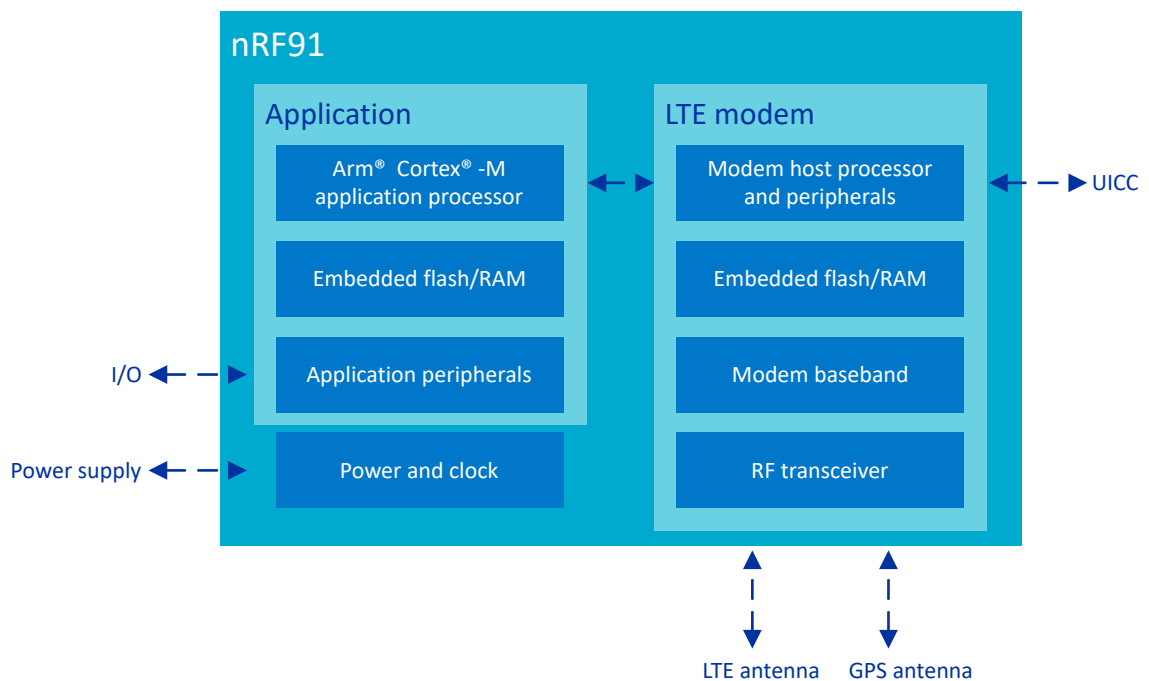

Figure 113: LTE modem within the nRF91

Application and modem domains interact through the interprocessor communication (IPC) mechanism. The LTE modem is accessible to users through the modem API.

The application processor is the system master and is responsible for starting and stopping the LTE modem. The LTE modem enables the clocks and power required for its own operation. The platform handles shared resources, such as clocks, and does not need user participation. In cases where a hard fault is detected in the modem, the application domain will perform a hard reset of the modem.

Note: For details regarding the modem API, see [nRF Connect SDK API documentation](#) and [nRF91 AT Commands](#).

The key features of the LTE modem are:

- Complete modem with baseband and RF transceiver
- 3GPP release 13 compliant LTE categories:
 - Cat-M1 (eMTC - enhanced machine type communication)
 - Cat-NB1 (NB-IoT - narrowband Internet of things)
- 3GPP release 14 compliant LTE categories:
 - Cat-NB1 (NB-IoT)
 - Cat-NB2 (NB-IoT)
- Power saving modes
- Supports LTE bands from 700 MHz to 2.2 GHz through a single 50 Ω antenna pin
 - ANT antenna pin is DC grounded
- RX sensitivity: -108 dBm for Cat-M1 and -114 dBm for Cat-NB1 and Cat-NB2
 - As defined in 3GPP conformance test specification TS 36.521-1
- 1.8 V MIPI RF Front-End (MIPI RFFE) digital control interface and MAGPIO control interface for external RF applications.
- LTE modem internal ADC that is also used for some AT command interface services, for example, for battery monitoring
- 1.8 V UICC (universal integrated circuit card) interface, based on ISO/IEC 7816-3 and compliant with:
 - UICC (ETSI TS 102 221)
 - eUICC (ETSI TS 103 383)

Note: The nRF9160 modem feature set depends on the modem firmware version and the application firmware.

7.1 SIM card interface

The LTE modem supports the universal integrated circuit card (UICC) interface.

Only UICCs with electrical interfaces specified in ISO/IEC 7816-3 are supported. UICCs with IC-USB, CLF or MMC interfaces are not supported.

The supported UICC/eUICC interface is compliant with:

- ETSI TS 102 221: Smart Cards; UICC-Terminal interface; Physical and logical characteristics
- ETSI TS 103 383: Smart Cards; Embedded UICC; Requirements Specification

The physical interface towards the eUICC is the same as that towards the removable UICC.

By default, only the class C (supply voltage 1.8 V nominal) operation is supported. Support for legacy class B (supply voltage 3.0 V nominal) operation must be built with external components, including an external power supply and the level shifters towards the LTE modem UICC interface.

The LTE modem supports powering down the UICC during PSM and eDRX idle mode if the UICC supports this feature as specified in 3GPP TS 24.301. To reach the lowest total power consumption of the complete cellular IoT product, only UICCs supporting power down mode during PSM and eDRX idle mode sleep intervals should be considered.

The LTE modem controls the physical interfaces towards the UICC and implements the transport protocol over the four-pin ISO/IEC 7816-3 interface:

- VCC (power supply) – LTE modem drives this
- CLK (clock signal) – LTE modem drives this
- RST (reset signal) – LTE modem drives this
- I/O (input/output serial data) – Bi-directional

The interface between the LTE modem, the UICC (SIM card) connector, and the ESD device is shown in the following figure.

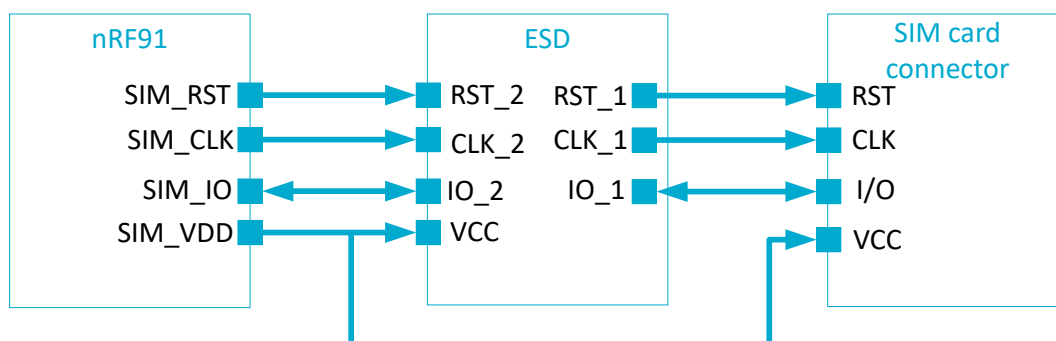

Figure 114: Connections between LTE modem, card connector, and the ESD device

Only standard transmission speeds are supported as specified in ETSI TS 102 221.

Note: Before removing the UICC, the LTE modem must be stopped through the modem API.

An electrostatic discharge (ESD) protection device compatible with UICC cards must be used between the removable card and the LTE modem, to protect LTE modem against harmful ESD from the card connector.

7.2 LTE coexistence interface

The LTE modem uses a dedicated three-pin interface for RF interference avoidance towards a companion radio device such as an external positioning device or *Bluetooth*[®] Low Energy device.

The interface has the following outputs:

- COEX0 – Output from the LTE modem to the external device. When internal GPS is used, COEX0 can be used as active high control for the external LNA component.
- COEX1 – Output from the LTE modem to the external device. When internal GPS is used, COEX1 delivers the GPS 1PPS (one pulse per second) time mark pulse. The 1PPS feature must not be used when LTE is enabled.
- COEX2 – Output from the LTE modem to the external device. When active high, this indicates that the LTE modem transceiver is turned on. COEX2 can also be treated as an active low grant from the LTE modem to the external device, indicating permission to transmit and receive.

Note: Using the COEX2 pin requires an external pull-down resistor in the 100 k Ω size range.

Note: For information on COEX signaling feature support, see the *nRF9160 Modem Firmware Release Notes* included in the latest [nRF9160 modem firmware](#).

The COEX interface timing in relation to the LTE modem state is shown in the following figure.

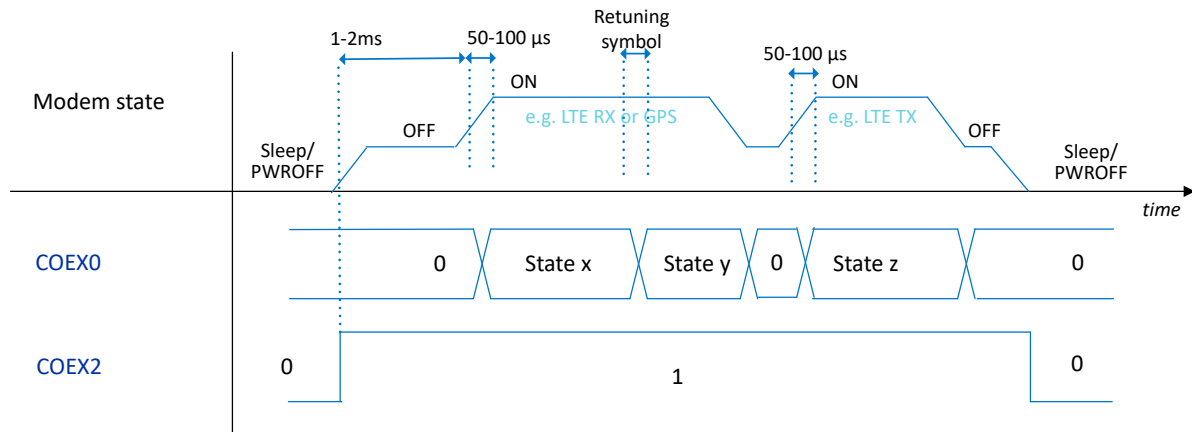

Figure 115: COEX interface timing

7.3 LTE RF control external interface

The LTE modem provides dedicated 1.8 V digital interfaces for controlling external RF applications, such as antenna tuner devices.

The LTE modem supports the following pins:

- MIPI RFFE interface pins – VIO, SCLK, SDATA
- MAGPIO interface pins – MAGPIO0, MAGPIO1, MAGPIO2

The LTE modem accurately drives the timing of these outputs according to the LTE protocol, to set the correct antenna tuner settings per used frequency, for example. The LTE modem API must be used to inform the LTE modem about the external RF application, so that LTE modem knows to drive it.

Note: For details regarding the modem API and supported RF external control features, see [nRF91 AT Commands](#).

Note: The MIPI RFFE capacitive load at SCLK or SDATA pins must not exceed 15 pF.

The MIPI RFFE interface timing in relation to modem state is shown in the following figure.

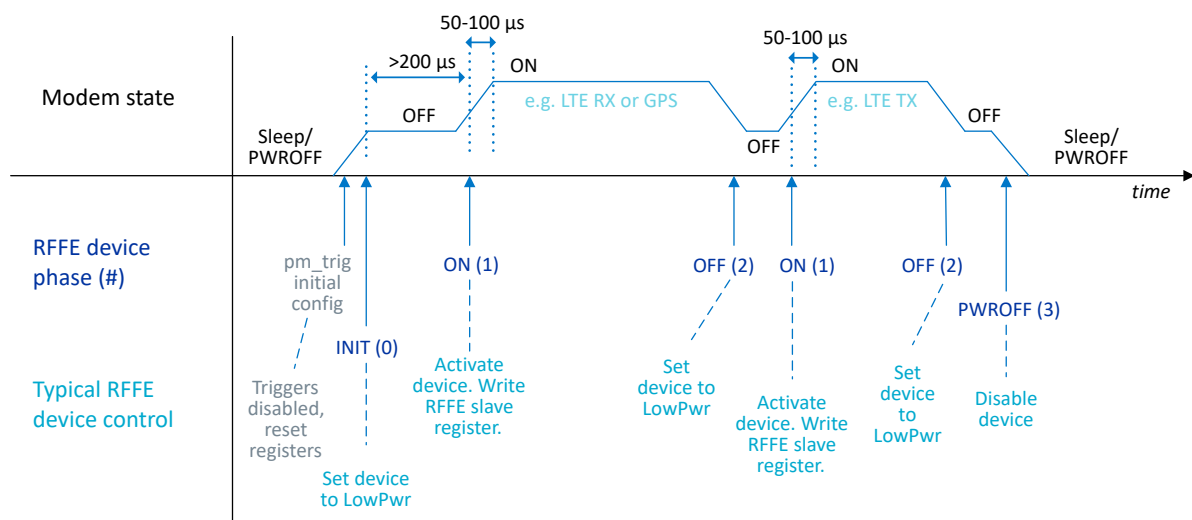

Figure 116: MIPI RFFE interface timing

The MAGPIO interface timing in relation to the LTE modem state is shown in the following figure.

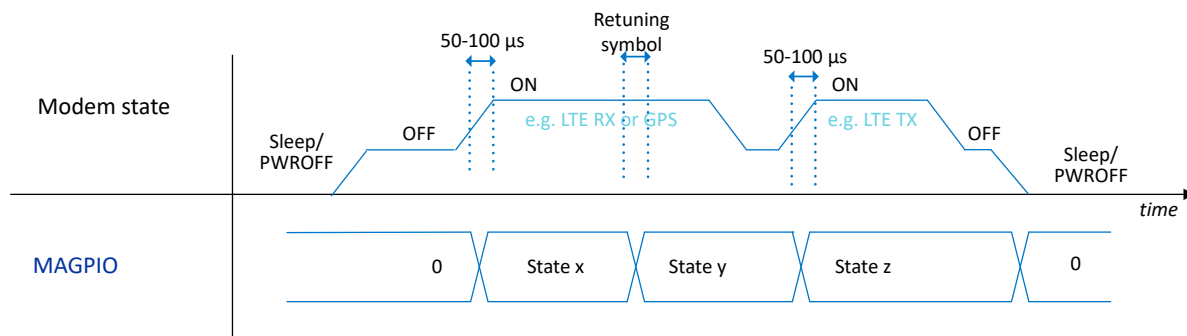

Figure 117: MAGPIO interface timing

7.4 RF front-end interface

The nRF9160 has a single-ended (SE) 50 Ω antenna interface to which an antenna is directly connected.

7.5 Electrical specification

7.5.1 Key RF parameters for Cat-M1

Note: For certification status, please refer to [Regulatory information](#) on page 524.

Symbol	Description	Min.	Typ.	Max.	Units
Supported LTE	Supported LTE standards		LTE Rel-13 Cat-M1 HD-FDD		
Bands supported	Bands supported		B1, B2, B3, B4, B5, B8, B12, B13, B18, B19, B20, B25, B26, B28, B66		
Transmission bandwidth	Maximum bandwidth		1.4		MHz

7.5.2 Key RF parameters for Cat-NB1 and Cat-NB2

Note: For certification status, please refer to [Regulatory information](#) on page 524.

Note: There is no foreseen NB-IoT network deployment for FCC bands closer than 200 kHz from band edge, hence our device will not transmit in FCC bands on channels that are closer than 200kHz to band edge.

Symbol	Description	Min.	Typ.	Max.	Units
Supported LTE	Supported LTE standards		LTE Rel-13 Cat-NB1 HD-FDD, LTE Rel-14 Cat-NB1 and Cat-NB2 HD-FDD		
Bands supported	Bands supported		B1, B2, B3, B4, B5, B8, B12, B13, B17, B19, B20, B25, B26, B28, B66		
Transmission bandwidth	Maximum bandwidth		200		kHz

7.5.3 Receiver parameters for Cat-M1

Symbol	Description	Min.	Typ.	Max.	Units
Freq _{range_ANT_RX}	RX operation frequency range at ANT pin	729		2200	MHz
Z _{in}	Input impedance, single-ended		50		Ω
Sensitivity, low band	LTE 1.4 MHz without coverage extension	-103	-108		dBm
Sensitivity, mid band	LTE 1.4 MHz without coverage extension	-103	-107		dBm

7.5.4 Receiver parameters for Cat-NB1 and Cat-NB2

Symbol	Description	Min.	Typ.	Max.	Units
Freq _{range_ANT_RX}	RX operation frequency range at ANT pin	729		2200	MHz
Z _{in}	Input impedance, single-ended		50		Ω
Sensitivity, low band	NB 200 kHz without coverage extension	-108	-114		dBm
Sensitivity, mid band	NB 200 kHz without coverage extension	-108	-113		dBm

7.5.5 Transmitter parameters for Cat-M1

Symbol	Description	Min.	Typ.	Max.	Units
Freq _{range_ANT_TX}	TX operation frequency range at ANT pin	699		1980	MHz
Z _{out}	Output impedance, single-ended		50		Ω
Maximum output power	Maximum output power		23		dBm
Minimum output power	Minimum output power		-40		dBm
P _{out} maximum accuracy	P _{out} maximum accuracy		±2		dB

7.5.6 Transmitter parameters for Cat-NB1 and Cat-NB2

Symbol	Description	Min.	Typ.	Max.	Units
Freq _{range_ANT_TX}	TX operation frequency range at ANT pin	699		1980	MHz
Z _{out}	Output impedance, single-ended		50		Ω
Maximum output power	Maximum output power		23		dBm
Minimum output power	Minimum output power		-40		dBm
P _{out} maximum accuracy	P _{out} maximum accuracy		±2		dB

8 GPS receiver

GPS receiver operation is time multiplexed with the LTE modem, and GPS and QZSS position can be received while the LTE modem is in RRC Idle mode, power saving mode (PSM), or completely deactivated.

The application processor is the system master and responsible for starting and stopping the GPS receiver. GPS can be run standalone or concurrently with QZSS. The GPS and QZSS reception can be configured through the GNSS interface API.

Note: For details regarding the GNSS API, refer to [nRF Connect SDK API documentation](#).

Key features of the GPS receiver are as follows:

- GPS L1 C/A reception
- QZSS L1 C/A reception
- Optimized for low-power and low-cost IoT applications
- Modes of operation:
 - Single shot
 - Position fix per fixed interval, configurable to a value between 10 s to 65536 s: first start with cold start, sequential fixes with hot start if interval less than 65536 s and enough satellites have been found in the first start
 - Continuous tracking
- Power saving mode:
 - Duty-cycled continuous tracking operation
- One pulse per second (1PPS) signal:
 - A pulse repeating once per second, accurately synchronized to coordinated universal time (UTC) full seconds
 - For more details on 1PPS programmability and power vs. accuracy trade-offs, see GNSS API documentation
 - Available on device COEX1 pin
 - For more details, see [LTE modem](#) on page 424, coexistence interface
- Antenna interface:
 - External low-noise amplifier (LNA) with SAW filter recommended on the GPS antenna input
 - Dedicated GPS antenna, or shared antenna with LTE
 - GPS antenna pin is DC grounded

Note: There must be minimum 27dB attenuation to out of band power to avoid blocking high power RF signals to GPS receiver input. This can be achieved by using a SAW filter, for example, at the external LNA output.

8.1 Electrical specification

The following is a summary of GPS receiver performance parameters.

Condition	Value
Environment	Open sky
Temperature	25°C
GPS sleep clock source	TCXO

Table 50: Common typical conditions

Note: Local and temporal conditions might lead to considerable variation in TTFF, positioning accuracy, 1PPS signal accuracy.

The figures in the following table assume the use of an external low-noise amplifier (LNA) with SAW filter.

Symbol	Description	Value	Unit
Sensitivity, cold	Acquisition sensitivity, cold start	-145.5	dBm
Sensitivity, hot	Acquisition sensitivity, hot start	-147	dBm
Sensitivity, tracking	Tracking sensitivity	-155	dBm
TTFF, cold	Time to first fix (TTFF), cold start	36	s
TTFF, hot	TTFF, hot start	1.3	s
Accuracy, 2D, periodic	Positioning accuracy (CEP50), periodic tracking	5	m
Accuracy, 2D, continuous	Positioning accuracy (CEP50), continuous tracking	3	m
1PPS accuracy	1PPS signal accuracy, continuous tracking	±40	ns

Table 51: GPS electrical specification

9 Debug and trace

The debug and trace system offers a flexible and powerful mechanism for non-intrusive debugging.

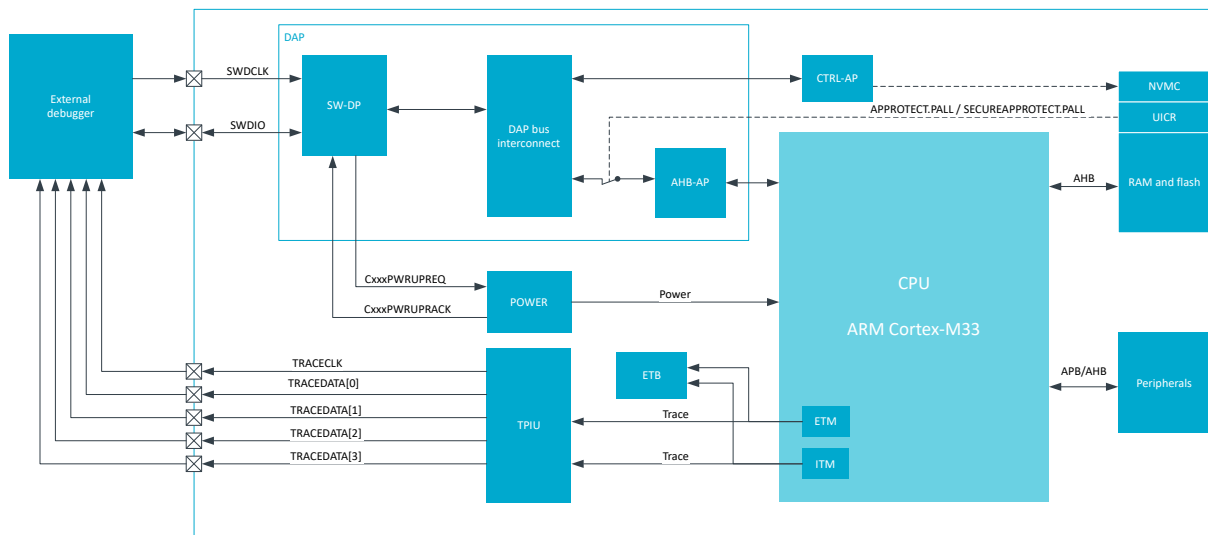

Figure 118: Debug and trace overview

The main features of the debug and trace system include:

- Two-pin serial wire debug (SWD) interface, protocol version 1
- Access port connection
 - Breakpoint unit (BPU) supports eight hardware breakpoint comparators
 - Data watchpoint and trace (DWT) unit supports four watchpoint comparators
 - Instrumentation trace macrocell (ITM)
 - Embedded trace macrocell (ETM)
 - Access protection through APPROTECT, ERASEPROTECT and SECUREAPPROTECT
- Embedded trace buffer (ETB)
- Trace port interface unit (TPIU)
 - 4-bit parallel trace of ITM and ETM trace data

Note: When a system contains multiple CPU domains, it is important to be aware that if one domain (subsystem A) has master rights on another domain (subsystem B), the master subsystem can access some data from the slave subsystem. In this example, even if subsystem B is locked by APPROTECT or ERASEPROTECT, subsystem A can access some data for subsystem B. Consequently, even if the security permissions are managed per subsystem, it is mandatory to have a global approach to the protection. Protecting a slave subsystem does not guarantee system security if the master subsystem is not protected.

9.1 Special consideration regarding debugger access

A debugger, if desired, can be restricted to debug non-secure code only, and access non-secure memory regions and peripherals using register [SECUREAPPROTECT](#) on page 46. Register [APPROTECT](#) on page 44 will block all debugger access.

Debugger accesses are controlled as described in table below.

Debugging capability	UICR.APPROTECT.PALL	UICR.SECUREAPPROTECT.PALL
Secure and non-secure code	Unprotected	Unprotected
Non-secure code only	Unprotected	Protected
No debugging possible	Protected	-

Table 52: Debugger access control

If a RAM or flash region has its permission set to allow code execution, the content of this region will be visible to the debugger even if the read permission is not set. This allows a debugger to display the content of the code being executed. For more about how to configure permissions, please refer to [SPU — System protection unit](#) on page 324.

9.2 DAP - Debug access port

An external debugger can access the device via the debug access port (DAP).

The DAP implements a standard Arm CoreSight serial wire debug port (SW-DP). The SW-DP implements the serial wire debug (SWD) protocol that is a two-pin serial interface, see SWDCLK and SWDIO illustrated in figure [Debug and trace overview](#) on page 432.

In addition to the default access port in the application CPU (AHB-AP), the DAP includes a custom control access port (CTRL-AP), described in more detail in [CTRL-AP - Control access port](#) on page 498.

Note:

- The SWDIO line has an internal pull-up resistor.
- The SWDCLK line has an internal pull-down resistor.

There are several access ports that connect to different parts of the system. An overview is given in the table below.

AP ID	Type	Description
0	AHB-AP	Application subsystem access port
3	APB-AP	CoreSight subsystem access port
4	CTRL-AP	Application subsystem control access port

Table 53: Access port overview

The standard Arm components are documented in *Arm CoreSight SoC-400 Technical Reference Manual, revision r3p2*. The control access port (CTRL-AP) is proprietary, and described in more detail in [CTRL-AP - Control access port](#) on page 498.

9.3 Debug interface mode

Before the external debugger can access the CPU's access port (AHB-AP) or the control access port (CTRL-AP), the debugger must first request the device to power up via CxxxPWRUPREQ in the SWJ-DP.

As long as the debugger is requesting power via CxxxPWRUPREQ, the device will be in debug interface mode. Otherwise, the device is in normal mode. When a debug session is over, the external debugger

9.6 Electrical specification

9.6.1 Trace port

Symbol	Description	Min.	Typ.	Max.	Units
T_{Cyc}	Clock period, as defined by ARM (See ARM Infocenter, Embedded Trace Macrocell Architecture Specification, Trace Port Physical Interface, Timing specifications)	62.5			ns

9.7 Trace

The nRF9160 supports ETM and ITM trace.

Available trace sinks:

- 2 kB internal embedded trace buffer (ETB)
- External trace port interface through TPIU

Trace data from the ETM and the ITM can be sent to an internal embedded trace buffer (ETB) or an external debugger via a 4-bit wide parallel trace port (TPIU), see TRACEDATA[0] through TRACEDATA[3], and TRACECLK in [Debug and trace overview](#) on page 432.

The following diagram shows the trace components architecture of the device's embedded Arm CoreSight subsystem.

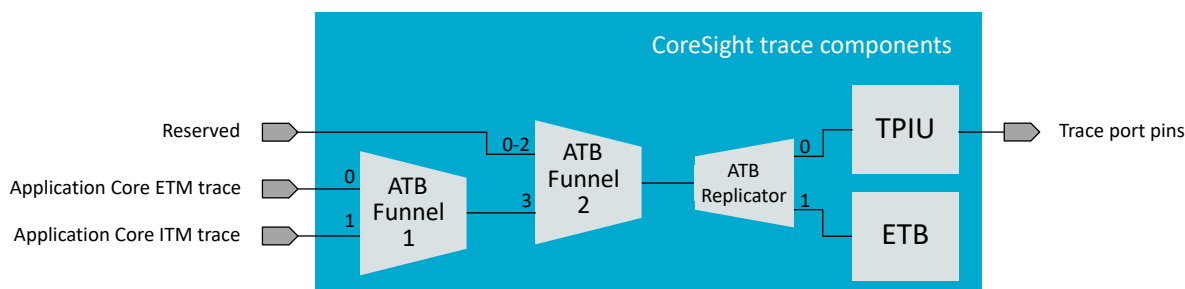

Figure 119: Trace components architecture

The standard Arm components are documented in *Arm CoreSight SoC-400 Technical Reference Manual, revision r3p2*. For details on how to use the trace capabilities, please read the debug documentation of your IDE.

TPIU's trace pins are multiplexed with GPIOs, see [Pin assignments](#) on page 511 for more information.

Note: To configure the trace data delivery to the device trace port, use the MDK system start-up file included as of MDK version 8.26.0.

Trace speed is configured in the [TRACEPORTSPEED \(Retained\)](#) on page 509 register. The speed of the trace pins depends on the DRIVE setting of the GPIOs that the trace pins are multiplexed with. See [GPIO — General purpose input/output](#) on page 164 for information about how to set drive settings. Only S0S1 and H0H1 drives are suitable for debugging. S0S1 is the default DRIVE at reset. If parallel or serial trace port signals are not fast enough in the debugging conditions, all GPIOs in use for tracing should be set to high drive (H0H1). The user shall make sure that DRIVE setting for these GPIOs is not overwritten by software during the debugging session.

9.7.1 ATB Funnel

The ARM® ATB Funnel funnels trace bus messages from several sources into one output bus.

This document only provides a register-level description of this ARM component. See the [ARM® CoreSight™ SoC-400 Technical Reference Manual](#) for more details

9.7.1.1 Registers

Instances

Instance	Base address	TrustZone			Split access	Description
		Map	Att	DMA		
ATBFUNNEL1	0xE005A000	HF	NS	NA	No	ATBFUNNEL unit 1
ATBFUNNEL2	0xE005B000	HF	NS	NA	No	ATBFUNNEL unit 2

Register overview

Register	Offset	TZ	Description
CTRLREG	0x000		The IDFILTER0 register enables the programming of ID filtering for master port 0.
PRIORITYCTRLREG	0x004		The Priority_Ctrl_Reg register defines the order in which inputs are selected. Each 3-bit field is a priority for each particular slave interface.
ITATBDATA0	0xEEC		The ITATBDATA0 register performs different functions depending on whether the access is a read or a write.
ITATBCTR2	0xEF0		The ITATBCTR2 register performs different functions depending on whether the access is a read or a write.
ITATBCTR1	0xEF4		The ITATBCTR1 register performs different functions depending on whether the access is a read or a write.
ITATBCTR0	0xEF8		The ITATBCTR0 register performs different functions depending on whether the access is a read or a write.
ITCTRL	0xF00		The ITCTRL register enables the component to switch from a functional mode, which is the default behavior, to integration mode where the inputs and outputs of the component can be directly controlled for the purposes of integration testing and topology detection.
CLAIMSET	0xFA0		Software can use the claim tag to coordinate application and debugger access to trace unit functionality. The claim tags have no effect on the operation of the component. The CLAIMSET register sets bits in the claim tag, and determines the number of claim bits implemented.
CLAIMCLR	0xFA4		Software can use the claim tag to coordinate application and debugger access to trace unit functionality. The claim tags have no effect on the operation of the component. The CLAIMCLR register sets the bits in the claim tag to 0 and determines the current value of the claim tag.
LAR	0xFB0		This is used to enable write access to device registers.
LSR	0xFB4		This indicates the status of the lock control mechanism. This lock prevents accidental writes by code under debug. Accesses to the extended stimulus port registers are not affected by the lock mechanism. This register must always be present although there might not be any lock access control mechanism. The lock mechanism, where present and locked, must block write accesses to any control register, except the Lock Access Register. For most components this covers all registers except for the Lock Access Register.
AUTHSTATUS	0xFB8		Indicates the current level of tracing permitted by the system
DEVID	0xFC8		Indicates the capabilities of the component.
DEVTYPE	0xFCC		The DEVTYPE register provides a debugger with information about the component when the Part Number field is not recognized. The debugger can then report this information.
PIDR4	0xFD0		Coresight peripheral identification registers.

Register	Offset	TZ	Description
PIDR[0]	0xFE0		Coresight peripheral identification registers.
PIDR[1]	0xFE4		Coresight peripheral identification registers.
PIDR[2]	0xFE8		Coresight peripheral identification registers.
PIDR[3]	0xFEC		Coresight peripheral identification registers.
CIDR[0]	0xFF0		Coresight component identification registers.
CIDR[1]	0xFF4		Coresight component identification registers.
CIDR[2]	0xFF8		Coresight component identification registers.
CIDR[3]	0xFFC		Coresight component identification registers.

9.7.1.1.1 CTRLREG

Address offset: 0x000

The IDFILTER0 register enables the programming of ID filtering for master port 0.

Bit number	31 30 29 28 27 26 25 24 23 22 21 20 19 18 17 16 15 14 13 12 11 10 9 8 7 6 5 4 3 2 1 0																														
ID	I I I I H G F E D C B A																														
Reset 0x00000000	0 0																														
ID	R/W	Field	Value ID	Value	Description																										
A-H	RW	ENS[i] (i=0..7)	Disabled	0	Enable slave port i. Slave port disabled. This excludes the port from the priority selection scheme.																										
			Enabled	1	Slave port enabled.																										
I	RW	HT		[0:14]	Hold Time. The formatting scheme can become inefficient when fast switching occurs, and you can use this setting to minimize switching. When a source has nothing to transmit, then another source is selected irrespective of the minimum number of transactions. The ATB funnel holds for the minimum hold time and one additional transaction. The actual hold time is the register value plus 1. The maximum value that can be entered is 0b1110 and this equates to 15 transactions. 0b1111 is reserved.																										

9.7.1.1.2 PRIORITYCTRLREG

Address offset: 0x004

The Priority_Ctrl_Reg register defines the order in which inputs are selected. Each 3-bit field is a priority for each particular slave interface.

Bit number	31 30 29 28 27 26 25 24 23 22 21 20 19 18 17 16 15 14 13 12 11 10 9 8 7 6 5 4 3 2 1 0																														
ID	H H H G G G F F F E E E D D D C C C B B B A A A																														
Reset 0x00000000	0 0																														
ID	R/W	Field	Value ID	Value	Description																										
A-H	RW	PRIPORT[i] (i=0..7)		[0:7]	Priority value of port number i.																										

9.7.1.1.3 ITATBDATA0

Address offset: 0xEEC

The ITATBDATA0 register performs different functions depending on whether the access is a read or a write.

Bit number	31	30	29	28	27	26	25	24	23	22	21	20	19	18	17	16	15	14	13	12	11	10	9	8	7	6	5	4	3	2	1	0
ID	Q P O N M L K J I H G F E D C B A																															
Reset 0x00000000	0 0																															
ID	R/W	Field	Value ID	Value	Description																											
A-Q	RW	ATDATA[i] (i=0..16)			A read access returns the value of a pin on atdatas_x of the enabled port. A write access writes to the corresponding atdatam pin of the enabled port.																											
			Low	0	Pin is logic 0.																											
			High	1	Pin is logic 1.																											

9.7.1.1.4 ITATBCTR2

Address offset: 0xEF0

The ITATBCTR2 register performs different functions depending on whether the access is a read or a write.

Bit number	31	30	29	28	27	26	25	24	23	22	21	20	19	18	17	16	15	14	13	12	11	10	9	8	7	6	5	4	3	2	1	0
ID	B A																															
Reset 0x00000000	0 0																															
ID	R/W	Field	Value ID	Value	Description																											
A	RW	ATREADY			A read access returns the value of atreadym. A write access outputs the data to afvalids[n], where the value of the CTRLREG at 0x000 defines n.																											
			Low	0	Pin is logic 0.																											
			High	1	Pin is logic 1.																											
B	RW	AFVALID			A read access returns the value of afvalidm. A write access outputs the data to atreadys[n], where the value of the CTRLREG at 0x000 defines n.																											
			Low	0	Pin is logic 0.																											
			High	1	Pin is logic 1.																											

9.7.1.1.5 ITATBCTR1

Address offset: 0xEF4

The ITATBCTR1 register performs different functions depending on whether the access is a read or a write.

Bit number	31	30	29	28	27	26	25	24	23	22	21	20	19	18	17	16	15	14	13	12	11	10	9	8	7	6	5	4	3	2	1	0
ID	A A A A A A A																															
Reset 0x00000000	0 0																															
ID	R/W	Field	Value ID	Value	Description																											
A	RW	ATVALIDM0			A read returns the value of the atids[n] signals, where the value of the Control Register at 0x000 defines n. A write outputs the value to the atidm port.																											
			Low	0	Pin is logic 0.																											
			High	1	Pin is logic 1.																											

9.7.1.1.6 ITATBCTR0

Address offset: 0xEF8

The ITATBCTR0 register performs different functions depending on whether the access is a read or a write.

Bit number	31 30 29 28 27 26 25 24 23 22 21 20 19 18 17 16 15 14 13 12 11 10 9 8 7 6 5 4 3 2 1 0																																		
ID																														C	C			B	A
Reset 0x00000000	0 0																																		
ID	R/W	Field	Value ID	Value	Description																														
A	RW	ATVALID			A read returns the value of the atvalids[n] signal, where the value of the CTRLREG at 0x000 defines n. A write outputs the value to atvalidm.																														
			Low	0	Pin is logic 0.																														
			High	1	Pin is logic 1.																														
B	RW	AFREADY			A read returns the value of the afreadys[n] signal, where the value of the Ctrl_Reg at 0x000 defines n. A write outputs the value to afreadym.																														
			Low	0	Pin is logic 0.																														
			High	1	Pin is logic 1.																														
C	RW	ATBYTES			A read returns the value of the atbytes[n] signal, where the value of the Ctrl_Reg at 0x000 defines n. A write outputs the value to atbytesm.																														
			Low	0	Pin is logic 0.																														
			High	1	Pin is logic 1.																														

9.7.1.1.7 ITCTRL

Address offset: 0xF00

The ITCTRL register enables the component to switch from a functional mode, which is the default behavior, to integration mode where the inputs and outputs of the component can be directly controlled for the purposes of integration testing and topology detection.

Bit number	31 30 29 28 27 26 25 24 23 22 21 20 19 18 17 16 15 14 13 12 11 10 9 8 7 6 5 4 3 2 1 0																														
ID																														A	
Reset 0x00000000	0 0																														
ID	R/W	Field	Value ID	Value	Description																										
A	RW	IME			Integration Mode Enable.																										
			Disabled	0	Integration mode disabled.																										
			Enabled	1	Integration mode enabled.																										

9.7.1.1.8 CLAIMSET

Address offset: 0xFA0

Software can use the claim tag to coordinate application and debugger access to trace unit functionality. The claim tags have no effect on the operation of the component. The CLAIMSET register sets bits in the claim tag, and determines the number of claim bits implemented.

Bit number	31 30 29 28 27 26 25 24 23 22 21 20 19 18 17 16 15 14 13 12 11 10 9 8 7 6 5 4 3 2 1 0																																
ID																														D	C	B	A
Reset 0x00000000	0 0																																
ID	R/W	Field	Value ID	Value	Description																												
A-D	RW	BIT[i] (i=0..3)			Set claim bit i and check if bit is implemented or not.																												
			NotImplemented	0	Claim bit i is not implemented.																												
			Implemented	1	Claim bit i is implemented.																												
			Set	1	Set claim bit i.																												

9.7.1.1.9 CLAIMCLR

Address offset: 0xFA4

Software can use the claim tag to coordinate application and debugger access to trace unit functionality. The claim tags have no effect on the operation of the component. The CLAIMCLR register sets the bits in the claim tag to 0 and determines the current value of the claim tag.

Bit number	31 30 29 28 27 26 25 24 23 22 21 20 19 18 17 16 15 14 13 12 11 10 9 8 7 6 5 4 3 2 1 0																																	
ID																															D	C	B	A
Reset 0x00000000	0 0																																	
ID	R/W	Field	Value ID	Value	Description																													
A-D	RW	BIT[i] (i=0..3)			Read or clear claim bit i.																													
			Cleared	0	Claim bit i is not set.																													
			Set	1	Claim bit i is set.																													
			Clear	1	Clear claim bit i.																													

9.7.1.1.10 LAR

Address offset: 0xFB0

This is used to enable write access to device registers.

Bit number	31 30 29 28 27 26 25 24 23 22 21 20 19 18 17 16 15 14 13 12 11 10 9 8 7 6 5 4 3 2 1 0																														
ID	A	A	A	A	A	A	A	A	A	A	A	A	A	A	A	A	A	A	A	A	A	A	A	A	A	A	A	A	A	A	
Reset 0x00000000	0 0																														
ID	R/W	Field	Value ID	Value	Description																										
A	RW	ACCESS			A write of 0xC5ACCE55 enables further write access to this device. Any other write removes write access.																										
			UnLock	0xC5ACCE55	Unlock register interface.																										

9.7.1.1.11 LSR

Address offset: 0xFB4

This indicates the status of the lock control mechanism. This lock prevents accidental writes by code under debug. Accesses to the extended stimulus port registers are not affected by the lock mechanism. This register must always be present although there might not be any lock access control mechanism. The lock mechanism, where present and locked, must block write accesses to any control register, except the Lock Access Register. For most components this covers all registers except for the Lock Access Register.

Bit number	31 30 29 28 27 26 25 24 23 22 21 20 19 18 17 16 15 14 13 12 11 10 9 8 7 6 5 4 3 2 1 0																																
ID																															C	B	A
Reset 0x00000000	0 0																																
ID	R/W	Field	Value ID	Value	Description																												
A	RW	PRESENT			Indicates that a lock control mechanism exists for this device.																												
			NotImplemented	0	No lock control mechanism exists, writes to the Lock Access Register are ignored.																												
			Implemented	1	Lock control mechanism is present.																												
B	RW	LOCKED			Returns the current status of the Lock.																												
			UnLocked	0	Write access is allowed to this device.																												
			Locked	1	Write access to the component is blocked. All writes to control registers are ignored. Reads are permitted.																												
C	RW	TYPE			Indicates if the Lock Access Register is implemented as 8-bit or 32-bit.																												
			Bits32	0	This component implements a 32-bit Lock Access Register.																												
			Bits8	1	This component implements an 8-bit Lock Access Register.																												

9.7.1.1.12 AUTHSTATUS

Address offset: 0xFB8

Indicates the current level of tracing permitted by the system

Bit number	31 30 29 28 27 26 25 24 23 22 21 20 19 18 17 16 15 14 13 12 11 10 9 8 7 6 5 4 3 2 1 0																																														
ID																													D	D	C	C	B	B	A	A											
Reset 0x00000000	0 0																																														
ID	R/W	Field	Value ID	Value	Description																																										
A	RW	NSID	NotImplemented	0	Non-secure Invasive Debug The feature is not implemented.																																										
			Implemented	1	The feature is implemented.																																										
B	RW	NSNID	NotImplemented	0	Non-secure Non-Invasive Debug The feature is not implemented.																																										
			Implemented	1	The feature is implemented.																																										
C	RW	SID	NotImplemented	0	Secure Invasive Debug The feature is not implemented.																																										
			Implemented	1	The feature is implemented.																																										
D	RW	SNID	NotImplemented	0	Secure Non-Invasive Debug The feature is not implemented.																																										
			Implemented	1	The feature is implemented.																																										

9.7.1.1.13 DEVID

Address offset: 0xFC8

Indicates the capabilities of the component.

Bit number	31 30 29 28 27 26 25 24 23 22 21 20 19 18 17 16 15 14 13 12 11 10 9 8 7 6 5 4 3 2 1 0																																										
ID																													A	A	A	A											
Reset 0x00000000	0 0																																										
ID	R/W	Field	Value ID	Value	Description																																						
A	R	PORTCOUNT		[2:8]	Indicates the number of input ports connected. 0x0 and 0x1 are illegal values.																																						

9.7.1.1.14 DEVTYPE

Address offset: 0xFCC

The DEVTYPE register provides a debugger with information about the component when the Part Number field is not recognized. The debugger can then report this information.

Bit number	31 30 29 28 27 26 25 24 23 22 21 20 19 18 17 16 15 14 13 12 11 10 9 8 7 6 5 4 3 2 1 0																																														
ID																													B	B	B	B	A	A	A	A											
Reset 0x00000000	0 0																																														
ID	R/W	Field	Value ID	Value	Description																																										
A	R	MAJOR			The main type of the component																																										
			InputOutputDevice	2	Indicates that this component has ATB inputs and outputs.																																										
B	R	SUB			The sub-type of the component																																										
			Replicator	1	This component arbitrates ATB inputs mapping to ATB outputs.																																										

9.7.1.1.15 PIDR4

Address offset: 0xFD0

Coresight peripheral identification registers.

Bit number	31 30 29 28 27 26 25 24 23 22 21 20 19 18 17 16 15 14 13 12 11 10 9 8 7 6 5 4 3 2 1 0																															
ID																																
Reset 0x00000000	0 0																															
ID	R/W	Field	Value ID	Value	Description																											

9.7.1.1.16 PIDR[0]

Address offset: 0xFE0

Coresight peripheral identification registers.

Bit number	31 30 29 28 27 26 25 24 23 22 21 20 19 18 17 16 15 14 13 12 11 10 9 8 7 6 5 4 3 2 1 0																															
ID																																
Reset 0x00000000	0 0																															
ID	R/W	Field	Value ID	Value	Description																											

9.7.1.1.17 PIDR[1]

Address offset: 0xFE4

Coresight peripheral identification registers.

Bit number	31 30 29 28 27 26 25 24 23 22 21 20 19 18 17 16 15 14 13 12 11 10 9 8 7 6 5 4 3 2 1 0																															
ID																																
Reset 0x00000000	0 0																															
ID	R/W	Field	Value ID	Value	Description																											

9.7.1.1.18 PIDR[2]

Address offset: 0xFE8

Coresight peripheral identification registers.

Bit number	31 30 29 28 27 26 25 24 23 22 21 20 19 18 17 16 15 14 13 12 11 10 9 8 7 6 5 4 3 2 1 0																															
ID																																
Reset 0x00000000	0 0																															
ID	R/W	Field	Value ID	Value	Description																											

9.7.1.1.19 PIDR[3]

Address offset: 0xFEC

Coresight peripheral identification registers.

Bit number	31 30 29 28 27 26 25 24 23 22 21 20 19 18 17 16 15 14 13 12 11 10 9 8 7 6 5 4 3 2 1 0																															
ID																																
Reset 0x00000000	0 0																															
ID	R/W	Field	Value ID	Value	Description																											

9.7.1.1.20 CIDR[0]

Address offset: 0xFF0

Coresight component identification registers.

Bit number	31	30	29	28	27	26	25	24	23	22	21	20	19	18	17	16	15	14	13	12	11	10	9	8	7	6	5	4	3	2	1	0	
ID																																	
Reset 0x00000000	0	0	0	0	0	0	0	0	0	0	0	0	0	0	0	0	0	0	0	0	0	0	0	0	0	0	0	0	0	0	0	0	0
ID	R/W	Field	Value ID	Value	Description																												

9.7.1.1.21 CIDR[1]

Address offset: 0xFF4

Coresight component identification registers.

Bit number	31	30	29	28	27	26	25	24	23	22	21	20	19	18	17	16	15	14	13	12	11	10	9	8	7	6	5	4	3	2	1	0
ID																																
Reset 0x00000000	0	0	0	0	0	0	0	0	0	0	0	0	0	0	0	0	0	0	0	0	0	0	0	0	0	0	0	0	0	0	0	0
ID	R/W	Field	Value ID	Value	Description																											

9.7.1.1.22 CIDR[2]

Address offset: 0xFF8

Coresight component identification registers.

Bit number	31	30	29	28	27	26	25	24	23	22	21	20	19	18	17	16	15	14	13	12	11	10	9	8	7	6	5	4	3	2	1	0
ID																																
Reset 0x00000000	0	0	0	0	0	0	0	0	0	0	0	0	0	0	0	0	0	0	0	0	0	0	0	0	0	0	0	0	0	0	0	0
ID	R/W	Field	Value ID	Value	Description																											

9.7.1.1.23 CIDR[3]

Address offset: 0xFFC

Coresight component identification registers.

Bit number	31	30	29	28	27	26	25	24	23	22	21	20	19	18	17	16	15	14	13	12	11	10	9	8	7	6	5	4	3	2	1	0
ID																																
Reset 0x00000000	0	0	0	0	0	0	0	0	0	0	0	0	0	0	0	0	0	0	0	0	0	0	0	0	0	0	0	0	0	0	0	0
ID	R/W	Field	Value ID	Value	Description																											

9.7.2 ATB Replicator

The ARM® ATB Replicator replicates incoming trace bus messages across its outputs.

This document only provides a register-level description of this ARM component. See the [ARM® CoreSight™ SoC-400 Technical Reference Manual](#) for more details

9.7.2.1 Registers

Instances

Instance	Base address	TrustZone			Split access	Description
		Map	Att	DMA		
ATBREPLICATOR	0xE0058000	HF	NS	NA	No	ATBREPLICATOR

Register overview

Register	Offset	TZ	Description
IDFILTER0	0x000		The IDFILTER0 register enables the programming of ID filtering for master port 0.
IDFILTER1	0x004		The IDFILTER1 register enables the programming of ID filtering for master port 1.
ITATBCTR1	0xEF8		The ITATBCTR1 register returns the value of the atreadym0, atreadym1, and atvalids inputs in integration mode.
ITATBCTR0	0xEFC		The ITATBCTR0 register controls the value of the atvalidm0, atvalidm1, and atreadys outputs in integration mode.
ITCTRL	0xF00		The ITCTRL register enables the component to switch from a functional mode, which is the default behavior, to integration mode where the inputs and outputs of the component can be directly controlled for the purposes of integration testing and topology detection.
CLAIMSET	0xFA0		Software can use the claim tag to coordinate application and debugger access to trace unit functionality. The claim tags have no effect on the operation of the component. The CLAIMSET register sets bits in the claim tag, and determines the number of claim bits implemented.
CLAIMCLR	0xFA4		Software can use the claim tag to coordinate application and debugger access to trace unit functionality. The claim tags have no effect on the operation of the component. The CLAIMCLR register sets the bits in the claim tag to 0 and determines the current value of the claim tag.
LAR	0xFB0		This is used to enable write access to device registers.
LSR	0xFB4		This indicates the status of the lock control mechanism. This lock prevents accidental writes by code under debug. Accesses to the extended stimulus port registers are not affected by the lock mechanism. This register must always be present although there might not be any lock access control mechanism. The lock mechanism, where present and locked, must block write accesses to any control register, except the Lock Access Register. For most components this covers all registers except for the Lock Access Register.
AUTHSTATUS	0xFB8		Indicates the current level of tracing permitted by the system
DEVID	0xFC8		Indicates the capabilities of the component.
DEVTYPE	0xFCC		The DEVTYPE register provides a debugger with information about the component when the Part Number field is not recognized. The debugger can then report this information.
PIDR4	0xFD0		Coresight peripheral identification registers.
PIDR[0]	0xFE0		Coresight peripheral identification registers.
PIDR[1]	0xFE4		Coresight peripheral identification registers.
PIDR[2]	0xFE8		Coresight peripheral identification registers.
PIDR[3]	0xFEC		Coresight peripheral identification registers.
CIDR[0]	0xFF0		Coresight component identification registers.
CIDR[1]	0xFF4		Coresight component identification registers.
CIDR[2]	0xFF8		Coresight component identification registers.
CIDR[3]	0xFFC		Coresight component identification registers.

9.7.2.1.1 IDFILTER0

Address offset: 0x000

The IDFILTER0 register enables the programming of ID filtering for master port 0.

Bit number	31 30 29 28 27 26 25 24 23 22 21 20 19 18 17 16 15 14 13 12 11 10 9 8 7 6 5 4 3 2 1 0																														
ID	H G F E D C B A																														
Reset 0x00000000	0 0																														
ID	R/W	Field	Value ID	Value	Description																										
A-H	RW	ID0_[i]0_[i]F (i=0..7)	NotFiltered	0	Enable or disable ID filtering for IDs 0xi0_0xiF.																										
			Selected	1	Transactions with these IDs are passed on to ATB master port 0.																										
					Transactions with these IDs are discarded by the replicator.																										

9.7.2.1.2 IDFILTER1

Address offset: 0x004

The IDFILTER1 register enables the programming of ID filtering for master port 1.

Bit number	31 30 29 28 27 26 25 24 23 22 21 20 19 18 17 16 15 14 13 12 11 10 9 8 7 6 5 4 3 2 1 0																																					
ID																															H	G	F	E	D	C	B	A
Reset 0x00000000	0 0																																					
ID	R/W	Field	Value ID	Value	Description																																	
A-H	RW	ID1_[i]0_[i]F (i=0..7)			Enable or disable ID filtering for IDs 0xi0_0xiF.																																	
			NotFiltered	0	Transactions with these IDs are passed on to ATB master port 1.																																	
			Selected	1	Transactions with these IDs are discarded by the replicator.																																	

9.7.2.1.3 ITATBCTR1

Address offset: 0xEF8

The ITATBCTR1 register returns the value of the atreadym0, atreadym1, and atvalids inputs in integration mode.

Bit number	31 30 29 28 27 26 25 24 23 22 21 20 19 18 17 16 15 14 13 12 11 10 9 8 7 6 5 4 3 2 1 0																																
ID																															C	B	A
Reset 0x00000000	0 0																																
ID	R/W	Field	Value ID	Value	Description																												
A	RW	ATREADYM0			Reads the value of the atreadym0 input.																												
			Low	0	Pin is logic 0.																												
			High	1	Pin is logic 1.																												
B	RW	ATREADYM1			Reads the value of the atreadym1 input.																												
			Low	0	Pin is logic 0.																												
			High	1	Pin is logic 1.																												
C	RW	ATVALIDS			Reads the value of the atvalids input.																												
			Low	0	Pin is logic 0.																												
			High	1	Pin is logic 1.																												

9.7.2.1.4 ITATBCTR0

Address offset: 0xEFC

The ITATBCTR0 register controls the value of the atvalidm0, atvalidm1, and atreadys outputs in integration mode.

Bit number	31 30 29 28 27 26 25 24 23 22 21 20 19 18 17 16 15 14 13 12 11 10 9 8 7 6 5 4 3 2 1 0																																
ID																															C	B	A
Reset 0x00000000	0 0																																
ID	R/W	Field	Value ID	Value	Description																												
A	RW	ATVALIDM0			Sets the value of the atvalidm0 output.																												
			Low	0	Pin is logic 0.																												
			High	1	Pin is logic 1.																												
B	RW	ATVALIDM1			Sets the value of the atvalidm1 output.																												
			Low	0	Pin is logic 0.																												
			High	1	Pin is logic 1.																												
C	RW	ATREADYS			Sets the value of the atreadys output.																												
			Low	0	Pin is logic 0.																												
			High	1	Pin is logic 1.																												

9.7.2.1.5 ITCTRL

Address offset: 0xF00

The ITCTRL register enables the component to switch from a functional mode, which is the default behavior, to integration mode where the inputs and outputs of the component can be directly controlled for the purposes of integration testing and topology detection.

Bit number	31	30	29	28	27	26	25	24	23	22	21	20	19	18	17	16	15	14	13	12	11	10	9	8	7	6	5	4	3	2	1	0
ID																											A					
Reset 0x00000000	0 0																															
ID	R/W	Field	Value ID	Value	Description																											
A	RW	IME			Integration Mode Enable.																											
			Disabled	0	Integration mode disabled.																											
			Enabled	1	Integration mode enabled.																											

9.7.2.1.6 CLAIMSET

Address offset: 0xFA0

Software can use the claim tag to coordinate application and debugger access to trace unit functionality. The claim tags have no effect on the operation of the component. The CLAIMSET register sets bits in the claim tag, and determines the number of claim bits implemented.

Bit number	31	30	29	28	27	26	25	24	23	22	21	20	19	18	17	16	15	14	13	12	11	10	9	8	7	6	5	4	3	2	1	0
ID																											D	C	B	A		
Reset 0x00000000	0 0																															
ID	R/W	Field	Value ID	Value	Description																											
A-D	RW	BIT[i] (i=0..3)			Set claim bit i and check if bit is implemented or not.																											
			NotImplemented	0	Claim bit i is not implemented.																											
			Implemented	1	Claim bit i is implemented.																											
			Set	1	Set claim bit i.																											

9.7.2.1.7 CLAIMCLR

Address offset: 0xFA4

Software can use the claim tag to coordinate application and debugger access to trace unit functionality. The CLAIMCLR register sets the bits in the claim tag to 0 and determines the current value of the claim tag.

Bit number	31	30	29	28	27	26	25	24	23	22	21	20	19	18	17	16	15	14	13	12	11	10	9	8	7	6	5	4	3	2	1	0
ID																											D	C	B	A		
Reset 0x00000000	0 0																															
ID	R/W	Field	Value ID	Value	Description																											
A-D	RW	BIT[i] (i=0..3)			Read or clear claim bit i.																											
			Cleared	0	Claim bit i is not set.																											
			Set	1	Claim bit i is set.																											
			Clear	1	Clear claim bit i.																											

9.7.2.1.8 LAR

Address offset: 0xFB0

This is used to enable write access to device registers.

Bit number	31	30	29	28	27	26	25	24	23	22	21	20	19	18	17	16	15	14	13	12	11	10	9	8	7	6	5	4	3	2	1	0
ID	A	A	A	A	A	A	A	A	A	A	A	A	A	A	A	A	A	A	A	A	A	A	A	A	A	A	A	A	A	A	A	A
Reset 0x00000000	0	0	0	0	0	0	0	0	0	0	0	0	0	0	0	0	0	0	0	0	0	0	0	0	0	0	0	0	0	0	0	
ID	R/W	Field	Value ID	Value	Description																											
A	RW	ACCESS			A write of 0xC5ACCE55 enables further write access to this device. Any other write removes write access.																											
			UnLock	0xC5ACCE55	Unlock register interface.																											

9.7.2.1.9 LSR

Address offset: 0xFB4

This indicates the status of the lock control mechanism. This lock prevents accidental writes by code under debug. Accesses to the extended stimulus port registers are not affected by the lock mechanism. This register must always be present although there might not be any lock access control mechanism. The lock mechanism, where present and locked, must block write accesses to any control register, except the Lock Access Register. For most components this covers all registers except for the Lock Access Register.

Bit number	31	30	29	28	27	26	25	24	23	22	21	20	19	18	17	16	15	14	13	12	11	10	9	8	7	6	5	4	3	2	1	0		
ID																																C	B	A
Reset 0x00000000	0	0	0	0	0	0	0	0	0	0	0	0	0	0	0	0	0	0	0	0	0	0	0	0	0	0	0	0	0	0	0	0		
ID	R/W	Field	Value ID	Value	Description																													
A	RW	PRESENT			Indicates that a lock control mechanism exists for this device.																													
			NotImplemented	0	No lock control mechanism exists, writes to the Lock Access Register are ignored.																													
			Implemented	1	Lock control mechanism is present.																													
B	RW	LOCKED			Returns the current status of the Lock.																													
			UnLocked	0	Write access is allowed to this device.																													
			Locked	1	Write access to the component is blocked. All writes to control registers are ignored. Reads are permitted.																													
C	RW	TYPE			Indicates if the Lock Access Register is implemented as 8-bit or 32-bit.																													
			Bits32	0	This component implements a 32-bit Lock Access Register.																													
			Bits8	1	This component implements an 8-bit Lock Access Register.																													

9.7.2.1.10 AUTHSTATUS

Address offset: 0xFB8

Indicates the current level of tracing permitted by the system

Bit number	31	30	29	28	27	26	25	24	23	22	21	20	19	18	17	16	15	14	13	12	11	10	9	8	7	6	5	4	3	2	1	0								
ID																																	D	D	C	C	B	B	A	A
Reset 0x00000000	0	0	0	0	0	0	0	0	0	0	0	0	0	0	0	0	0	0	0	0	0	0	0	0	0	0	0	0	0	0	0	0	0	0	0	0	0	0		
ID	R/W	Field	Value ID	Value	Description																																			
A	RW	NSID			Non-secure Invasive Debug																																			
			NotImplemented	0	The feature is not implemented.																																			
			Implemented	1	The feature is implemented.																																			
B	RW	NSNID			Non-secure Non-Invasive Debug																																			
			NotImplemented	0	The feature is not implemented.																																			
			Implemented	1	The feature is implemented.																																			
C	RW	SID			Secure Invasive Debug																																			
			NotImplemented	0	The feature is not implemented.																																			
			Implemented	1	The feature is implemented.																																			
D	RW	SNID			Secure Non-Invasive Debug																																			
			NotImplemented	0	The feature is not implemented.																																			

Bit number	31	30	29	28	27	26	25	24	23	22	21	20	19	18	17	16	15	14	13	12	11	10	9	8	7	6	5	4	3	2	1	0
ID	D D C C B B A A																															
Reset 0x00000000	0 0																															
ID	R/W	Field	Value ID	Value	Description																											
			Implemented	1	The feature is implemented.																											

9.7.2.1.11 DEVID

Address offset: 0xFC8

Indicates the capabilities of the component.

Bit number	31	30	29	28	27	26	25	24	23	22	21	20	19	18	17	16	15	14	13	12	11	10	9	8	7	6	5	4	3	2	1	0
ID	A A A A																															
Reset 0x00000000	0 0																															
ID	R/W	Field	Value ID	Value	Description																											
A	R	PORTNUM		[0:15]	Indicates the number of master ports implemented.																											

9.7.2.1.12 DEVTYPE

Address offset: 0xFCC

The DEVTYPE register provides a debugger with information about the component when the Part Number field is not recognized. The debugger can then report this information.

Bit number	31	30	29	28	27	26	25	24	23	22	21	20	19	18	17	16	15	14	13	12	11	10	9	8	7	6	5	4	3	2	1	0
ID	B B B B A A A A																															
Reset 0x00000000	0 0																															
ID	R/W	Field	Value ID	Value	Description																											
A	R	MAJOR			The main type of the component																											
			InputOutputDevice	2	Indicates that this component has ATB inputs and outputs.																											
B	R	SUB			The sub-type of the component																											
			Replicator	2	Indicates that this component replicates trace from a single source to multiple targets.																											

9.7.2.1.13 PIDR4

Address offset: 0xFD0

Coresight peripheral identification registers.

Bit number	31	30	29	28	27	26	25	24	23	22	21	20	19	18	17	16	15	14	13	12	11	10	9	8	7	6	5	4	3	2	1	0
ID																																
Reset 0x00000000	0 0																															
ID	R/W	Field	Value ID	Value	Description																											

9.7.2.1.14 PIDR[0]

Address offset: 0xFE0

Coresight peripheral identification registers.

Bit number	31	30	29	28	27	26	25	24	23	22	21	20	19	18	17	16	15	14	13	12	11	10	9	8	7	6	5	4	3	2	1	0		
ID																																		
Reset 0x00000000	0	0	0	0	0	0	0	0	0	0	0	0	0	0	0	0	0	0	0	0	0	0	0	0	0	0	0	0	0	0	0	0	0	0
ID	R/W	Field	Value ID	Value	Description																													

9.7.2.1.15 PIDR[1]

Address offset: 0xFE4

Coresight peripheral identification registers.

Bit number	31	30	29	28	27	26	25	24	23	22	21	20	19	18	17	16	15	14	13	12	11	10	9	8	7	6	5	4	3	2	1	0	
ID																																	
Reset 0x00000000	0	0	0	0	0	0	0	0	0	0	0	0	0	0	0	0	0	0	0	0	0	0	0	0	0	0	0	0	0	0	0	0	0
ID	R/W	Field	Value ID	Value	Description																												

9.7.2.1.16 PIDR[2]

Address offset: 0xFE8

Coresight peripheral identification registers.

Bit number	31	30	29	28	27	26	25	24	23	22	21	20	19	18	17	16	15	14	13	12	11	10	9	8	7	6	5	4	3	2	1	0	
ID																																	
Reset 0x00000000	0	0	0	0	0	0	0	0	0	0	0	0	0	0	0	0	0	0	0	0	0	0	0	0	0	0	0	0	0	0	0	0	0
ID	R/W	Field	Value ID	Value	Description																												

9.7.2.1.17 PIDR[3]

Address offset: 0xFEC

Coresight peripheral identification registers.

Bit number	31	30	29	28	27	26	25	24	23	22	21	20	19	18	17	16	15	14	13	12	11	10	9	8	7	6	5	4	3	2	1	0	
ID																																	
Reset 0x00000000	0	0	0	0	0	0	0	0	0	0	0	0	0	0	0	0	0	0	0	0	0	0	0	0	0	0	0	0	0	0	0	0	0
ID	R/W	Field	Value ID	Value	Description																												

9.7.2.1.18 CIDR[0]

Address offset: 0xFF0

Coresight component identification registers.

Bit number	31	30	29	28	27	26	25	24	23	22	21	20	19	18	17	16	15	14	13	12	11	10	9	8	7	6	5	4	3	2	1	0	
ID																																	
Reset 0x00000000	0	0	0	0	0	0	0	0	0	0	0	0	0	0	0	0	0	0	0	0	0	0	0	0	0	0	0	0	0	0	0	0	0
ID	R/W	Field	Value ID	Value	Description																												

9.7.2.1.19 CIDR[1]

Address offset: 0xFF4

Coresight component identification registers.

Bit number	31	30	29	28	27	26	25	24	23	22	21	20	19	18	17	16	15	14	13	12	11	10	9	8	7	6	5	4	3	2	1	0		
ID																																		
Reset 0x00000000	0	0	0	0	0	0	0	0	0	0	0	0	0	0	0	0	0	0	0	0	0	0	0	0	0	0	0	0	0	0	0	0	0	0
ID	R/W	Field	Value ID	Value	Description																													

9.7.2.1.20 CIDR[2]

Address offset: 0xFF8

Coresight component identification registers.

Bit number	31	30	29	28	27	26	25	24	23	22	21	20	19	18	17	16	15	14	13	12	11	10	9	8	7	6	5	4	3	2	1	0	
ID																																	
Reset 0x00000000	0	0	0	0	0	0	0	0	0	0	0	0	0	0	0	0	0	0	0	0	0	0	0	0	0	0	0	0	0	0	0	0	0
ID	R/W	Field	Value ID	Value	Description																												

9.7.2.1.21 CIDR[3]

Address offset: 0xFFC

Coresight component identification registers.

Bit number	31	30	29	28	27	26	25	24	23	22	21	20	19	18	17	16	15	14	13	12	11	10	9	8	7	6	5	4	3	2	1	0	
ID																																	
Reset 0x00000000	0	0	0	0	0	0	0	0	0	0	0	0	0	0	0	0	0	0	0	0	0	0	0	0	0	0	0	0	0	0	0	0	0
ID	R/W	Field	Value ID	Value	Description																												

9.7.3 ETB — Embedded trace buffer

The ARM embedded trace buffer captures trace and stores it in an on-chip RAM for later inspection.

This document only provides a register-level description of this ARM component. See the [Arm® CoreSight SoC-400 Technical Reference Manual](#) for more details.

9.7.3.1 Registers

Instances

Instance	Base address	TrustZone			Split access	Description
		Map	Att	DMA		
ETB	0xE0051000	HF	NS	NA	No	ETB

Register overview

Register	Offset	TZ	Description
RDP	0x4		ETB RAM Depth Register
STS	0xC		ETB Status Register
RRD	0x10		ETB RAM Read Data Register
RRP	0x14		ETB RAM Read Pointer Register
RWP	0x18		ETB RAM Write Pointer Register
TRG	0x1C		ETB Trigger Counter Register
CTL	0x20		ETB Control Register
RWD	0x24		ETB RAM Write Data Register
FFSR	0x300		ETB Formatter and Flush Status Register

Register	Offset	TZ	Description
FFCR	0x304		ETB Formatter and Flush Control Register
ITMISCOPO	0xEE0		Integration Test Miscellaneous Output Register 0
ITTRFLINACK	0xEE4		Integration Test Trigger In and Flush In Acknowledge Register
ITTRFLIN	0xEE8		Integration Test Trigger In and Flush In Register
ITATBDATA0	0xEEC		Integration Test ATB Data Register 0
ITATBCTR2	0xEF0		Integration Test ATB Control Register 2
ITATBCTR1	0xEF4		Integration Test ATB Control Register 1
ITATBCTR0	0xEF8		Integration Test ATB Control Register 0
ITCTRL	0xF00		Integration Mode Control Register
CLAIMSET	0xFA0		Claim Tag Set Register
CLAIMCLR	0xFA4		Claim Tag Clear Register
LAR	0xFB0		Lock Access Register
LSR	0xFB4		Lock Status Register
AUTHSTATUS	0xFB8		Authentication Status Register
DEVID	0xFC8		Device Configuration Register
DEVTYPE	0xFCC		Device Type Identifier Register
PERIPHID4	0xFD0		Peripheral ID4 Register
PERIPHID0	0xFE0		Peripheral ID0 Register
PERIPHID1	0xFE4		Peripheral ID1 Register
PERIPHID2	0xFE8		Peripheral ID2 Register
PERIPHID3	0xFEC		Peripheral ID3 Register
COMPID0	0xFF0		Component ID0 Register
COMPID1	0xFF4		Component ID1 Register
COMPID2	0xFF8		Component ID2 Register
COMPID3	0xFFC		Component ID3 Register

9.7.3.1.1 RDP

Address offset: 0x4

ETB RAM Depth Register

Defines the depth, in words, of the trace RAM. This value is configurable in the RTL, but fixed at synthesis. Supported depth in powers of 2 only.

Bit number	31	30	29	28	27	26	25	24	23	22	21	20	19	18	17	16	15	14	13	12	11	10	9	8	7	6	5	4	3	2	1	0
ID	A	A	A	A	A	A	A	A	A	A	A	A	A	A	A	A	A	A	A	A	A	A	A	A	A	A	A	A	A	A	A	
Reset 0x00000000	0	0	0	0	0	0	0	0	0	0	0	0	0	0	0	0	0	0	0	0	0	0	0	0	0	0	0	0	0	0	0	
ID	R/W	Field	Value ID	Value	Description																											
A	R	ETB_RAM_DEPTH			Defines the depth, in words, of the trace RAM.																											

9.7.3.1.2 STS

Address offset: 0xC

ETB Status Register

This register indicates the status of the ETB.

Bit number	31	30	29	28	27	26	25	24	23	22	21	20	19	18	17	16	15	14	13	12	11	10	9	8	7	6	5	4	3	2	1	0
ID																													D	C	B	A
Reset 0x00000008	0 1 0 0 0																															
ID	R/W	Field	Value ID	Value	Description																											
A	R	FULL			RAM Full. The flag indicates when the RAM write pointer has wrapped around.																											
B	R	TRIGGERED			The Triggered bit is set when a trigger has been observed. This does not indicate that a trigger has been embedded in the trace data by the formatter, but is determined by the programming of the Formatter and Flush Control Register.																											
C	R	ACQCOMP			The acquisition complete flag indicates that capture has been completed when the formatter stops because of any of the methods defined in the Formatter and Flush Control Register, or TraceCaptEn = 0. This also results in FtStopped in the Formatter and Flush Status Register going HIGH.																											
D	R	FEMPTY			Formatter pipeline empty. All data stored to RAM.																											

9.7.3.1.3 RRD

Address offset: 0x10

ETB RAM Read Data Register

When trace capture is disabled, the contents of the ETB Trace RAM at the location addressed by the RAM Read Pointer Registers are placed in this register. Reading this register increments the RAM Read Pointer Register and triggers a RAM access cycle. If trace capture is enabled (FtStopped=0, TraceCaptEn=1), and ETB RAM reading is attempted, a read from this register outputs 0xFFFFFFFF and the RAM Read Pointer Register does not auto-increment. A constant stream of 1s being output corresponds to a synchronization output in the formatter protocol, which is not applicable to the ETB, and so can be used to signify a read error, when formatting is enabled.

Bit number	31	30	29	28	27	26	25	24	23	22	21	20	19	18	17	16	15	14	13	12	11	10	9	8	7	6	5	4	3	2	1	0
ID	A A																															
Reset 0x00000000	0 0																															
ID	R/W	Field	Value ID	Value	Description																											
A	R	RAM_READ_DATA			Data read from the ETB Trace RAM.																											

9.7.3.1.4 RRP

Address offset: 0x14

ETB RAM Read Pointer Register

The RAM Read Pointer Register sets the read pointer used to read entries from the Trace RAM over the APB interface. When this register is written to, a RAM access is initiated. The RAM Read Data Register is then updated. The register can also be read to determine the current memory location being referenced. This register must not be written to when trace capture is enabled (FtStopped=0, TraceCaptEn=1). If access is attempted, the register is not updated.

Bit number	31	30	29	28	27	26	25	24	23	22	21	20	19	18	17	16	15	14	13	12	11	10	9	8	7	6	5	4	3	2	1	0																											
ID																													A	A	A	A	A	A	A	A	A	A	A	A	A	A	A	A	A	A	A	A	A	A	A	A	A	A	A	A	A	A	A
Reset 0x00000000	0 0																																																										
ID	R/W	Field	Value ID	Value	Description																																																						
A	RW	RAM_READ_POINTER			Sets the read pointer used to read entries from the Trace RAM over the APB interface.																																																						

9.7.3.1.5 RWP

Address offset: 0x18

ETB RAM Write Pointer Register

The RAM Write Pointer Register sets the write pointer used to write entries from the CoreSight bus into Trace RAM. During trace capture the pointer increments when the DataValid flag is asserted by the Formatter. When this register increments from its maximum value back to zero, the Full flag is set. This register can also be written to over APB to set the pointer for write accesses carried out through the APB interface. This register must not be written to when trace capture is enabled (FtStopped=0, TraceCaptEn=1). If access is attempted, the register is not updated. The register can also be read to determine the current memory location being referenced. It is recommended that addresses are 128-bit aligned when the formatter is used in normal or continuous modes.

Bit number	31	30	29	28	27	26	25	24	23	22	21	20	19	18	17	16	15	14	13	12	11	10	9	8	7	6	5	4	3	2	1	0																					
ID																								A	A	A	A	A	A	A	A	A	A	A	A	A	A	A	A	A	A	A	A	A	A	A	A	A	A	A	A	A	A
Reset 0x00000000	0	0	0	0	0	0	0	0	0	0	0	0	0	0	0	0	0	0	0	0	0	0	0	0	0	0	0	0	0	0	0	0																					
ID	R/W	Field	Value ID	Value	Description																																																
A	RW	RAM_WRITE_POINTER			Sets the write pointer used to write entries from the CoreSight bus into the Trace RAM.																																																

9.7.3.1.6 TRG

Address offset: 0x1C

ETB Trigger Counter Register

The Trigger Counter Register disables write access to the Trace RAM by stopping the Formatter after a defined number of words have been stored following the trigger event. The number of 32-bit words written into the Trace RAM following the trigger event is equal to the value stored in this register+1.

Bit number	31	30	29	28	27	26	25	24	23	22	21	20	19	18	17	16	15	14	13	12	11	10	9	8	7	6	5	4	3	2	1	0																				
ID																								A	A	A	A	A	A	A	A	A	A	A	A	A	A	A	A	A	A	A	A	A	A	A	A	A	A	A	A	A
Reset 0x00000000	0	0	0	0	0	0	0	0	0	0	0	0	0	0	0	0	0	0	0	0	0	0	0	0	0	0	0	0	0	0	0																					
ID	R/W	Field	Value ID	Value	Description																																															
A	RW	TRIGGER_COUNTER			The counter is used as follows:Trace after - The counter is set to a large value, slightly less than the number of entries in the RAM. Trace before - The counter is set to a small value. Trace about - The counter is set to half the depth of the Trace RAM. This register must not be written to when trace capture is enabled (FtStopped=0, TraceCaptEn=1). If a write is attempted, the register is not updated. A read access is permitted with trace capture enabled.																																															

9.7.3.1.7 CTL

Address offset: 0x20

ETB Control Register

This register controls trace capture by the ETB.

Bit number	31 30 29 28 27 26 25 24 23 22 21 20 19 18 17 16 15 14 13 12 11 10 9 8 7 6 5 4 3 2 1 0																														
ID	A																														
Reset	0x00000000																														
Value	0 0																														
ID	R/W	Field	Value ID	Value	Description																										
A	RW	TRACECAPTEN			ETB Trace Capture Enable. This is the master enable bit forcing FtStopped HIGH when TraceCaptEn is LOW. When capture is disabled, any remaining data in the ATB formatter is stored to RAM. When all data is stored the formatter outputs FtStopped. Capture is fully disabled, or complete, when FtStopped goes HIGH. See ETB Formatter and Flush Status Register, FFSR, 0x300.																										

9.7.3.1.8 RWD

Address offset: 0x24

ETB RAM Write Data Register

Data written to the ETB Trace RAM.

Bit number	31 30 29 28 27 26 25 24 23 22 21 20 19 18 17 16 15 14 13 12 11 10 9 8 7 6 5 4 3 2 1 0																														
ID	A A																														
Reset	0x00000000																														
Value	0 0																														
ID	R/W	Field	Value ID	Value	Description																										
A	RW	RAM_WRITE_DATA			Data written to the ETB Trace RAM. When trace capture is disabled, the contents of this register are placed into the ETB Trace RAM when this register is written to. Writing to this register increments the RAM Write Pointer Register. If trace capture is enabled, and this register is accessed, then a read from this register outputs 0xFFFFFFFF. Reads of this register never increment the RAM Write Pointer Register. A constant stream of 1s being output corresponds to a synchronization output from the ETB. If a write access is attempted, the data is not written into Trace RAM.																										

9.7.3.1.9 FFSR

Address offset: 0x300

ETB Formatter and Flush Status Register

This register indicates the implemented Trigger Counter multipliers and other supported features of the trigger system.

Bit number	31 30 29 28 27 26 25 24 23 22 21 20 19 18 17 16 15 14 13 12 11 10 9 8 7 6 5 4 3 2 1 0																															
ID																															B	A
Reset	0x00000002																															
Value	0 1 0																															
ID	R/W	Field	Value ID	Value	Description																											
A	R	FLINPROG			Flush In Progress. This is an indication of the current state of avalids.																											
B	R	FTSTOPPED			Formatter stopped. The formatter has received a stop request signal and all trace data and post-amble has been output. Any more trace data on the ATB interface is ignored and atready goes HIGH.																											

9.7.3.1.10 FFCR

Address offset: 0x304

ETB Formatter and Flush Control Register

This register controls the generation of stop, trigger, and flush events. To disable formatting and put the formatter into bypass mode, bits 1 and 0 must be clear. If both bits are set, then the formatter inserts triggers into the formatted stream. All three flush generating conditions can be enabled together. However, if a second or third flush event is generated then the current flush completes before the next flush is serviced. Flush from flushin takes priority over flush from Trigger, which in turn completes before a manually activated flush. All Trigger indication conditions can be enabled simultaneously although this can cause the appearance of multiple triggers if flush using trigger is also enabled. Both 'Stop On' settings can be enabled, although if flush on trigger, FOnTrig, is set up then none of the flushed data is stored. When the system stops, it returns ATREADY and does not store the accepted data packets. This is to avoid stalling of any other connected devices using a Trace Replicator. If an event in the Formatter and Flush Control Register is required, it must be enabled before the originating event starts. Because requests from flushes and triggers can originate in an asynchronous clock domain, the exact time the component acts on the request cannot be determined with respect to configuring the control. Note - To perform a stop on flush completion through a manually-generated flush request, two write operations to the register are required: one to enable the stop event, if it is not already enabled; one to generate the manual flush.

Bit number	31 30 29 28 27 26 25 24 23 22 21 20 19 18 17 16 15 14 13 12 11 10 9 8 7 6 5 4 3 2 1 0																																														
ID																												J	I	H	G	F	E	D	C											B	A
Reset 0x00000000	0 0																																														
ID	R/W	Field	Value ID	Value	Description																																										
A	RW	ENFTC			Do not embed Triggers into the formatted stream. Trace disable cycles and triggers are indicated by TRACECTL, where fitted. Can only be changed when FtStopped is HIGH. This bit is clear on reset.																																										
B	RW	ENFCONT			Continuous mode in the ETB corresponds to normal mode with the embedding of triggers. Can only be changed when FtStopped is HIGH. This bit is clear on reset.																																										
C	RW	FONFLIN			Set this bit to enable use of the flushin connection. This is clear on reset.																																										
D	RW	FONTRIG			Generate flush using Trigger event. Set this bit to cause a flush of data in the system when a Trigger Event occurs. This bit is clear on reset. A Trigger Event is defined as when the Trigger counter reaches zero (where fitted) or, in the case of the trigger counter being zero (or not fitted), when trigin is HIGH.																																										
E	RW	FONMAN			Setting this bit causes a flush to be generated. This is cleared when this flush has been serviced. This bit is clear on reset.																																										
F	RW	TRIGIN			Indicate a trigger on trigin being asserted.																																										
G	RW	TRIG EVT			Indicate a trigger on a Trigger Event.																																										
H	RW	TRIGFL			Indicates a trigger on Flush completion (afreadys being returned).																																										
I	RW	STOPFL			This forces the FIFO to drain off any part-completed packets. Setting this bit enables this function but this is clear on reset (disabled).																																										
J	RW	STOPTRIG			Stop the formatter after a Trigger Event is observed. Reset to disabled (zero).																																										

9.7.3.1.11 ITMISCOPO

Address offset: 0xEE0

Integration Test Miscellaneous Output Register 0

The Integration Test Miscellaneous Output Register 0 controls the values of some outputs from the ETB.

Bit number	31	30	29	28	27	26	25	24	23	22	21	20	19	18	17	16	15	14	13	12	11	10	9	8	7	6	5	4	3	2	1	0	
ID																																B	A
Reset	0x00000000																																
Value	0 0																																
ID	R/W	Field	Value ID	Value	Description																												
A	W	ACQCOMP			Set the value of acqcomp.																												
B	W	FULL			Set the value of full output port.																												

9.7.3.1.12 ITTRFLINACK

Address offset: 0xEE4

Integration Test Trigger In and Flush In Acknowledge Register

The Integration Test Trigger In and Flush In Acknowledge Register enables control of the triginack and flushinack outputs from the ETB.

Bit number	31	30	29	28	27	26	25	24	23	22	21	20	19	18	17	16	15	14	13	12	11	10	9	8	7	6	5	4	3	2	1	0	
ID																																B	A
Reset	0x00000000																																
Value	0 0																																
ID	R/W	Field	Value ID	Value	Description																												
A	W	TRIGINACK			Set the value of triginack.																												
B	W	FLUSHINACK			Set the value of flushinack.																												

9.7.3.1.13 ITTRFLIN

Address offset: 0xEE8

Integration Test Trigger In and Flush In Register

The Integration Test Trigger In and Flush In Register contains the values of the flushin and trigin inputs to the ETB.

Bit number	31	30	29	28	27	26	25	24	23	22	21	20	19	18	17	16	15	14	13	12	11	10	9	8	7	6	5	4	3	2	1	0	
ID																																B	A
Reset	0x00000000																																
Value	0 0																																
ID	R/W	Field	Value ID	Value	Description																												
A	R	TRIGIN			Read the value of trigin.																												
B	R	FLUSHIN			Read the value of flushin.																												

9.7.3.1.14 ITATBDATA0

Address offset: 0xEEC

Integration Test ATB Data Register 0

The Integration Test ATB Data Register 0 contains the value of the atdatas inputs to the ETB. The values are only valid when atvalids is HIGH.

Bit number	31	30	29	28	27	26	25	24	23	22	21	20	19	18	17	16	15	14	13	12	11	10	9	8	7	6	5	4	3	2	1	0
ID																												E	D	C	B	A
Reset 0x00000000	0 0																															
ID	R/W	Field	Value ID	Value	Description																											
A	R	ATDATA_0			Read the value of atdatas[0].																											
B	R	ATDATA_7			Read the value of atdatas[7].																											
C	R	ATDATA_15			Read the value of atdatas[15].																											
D	R	ATDATA_23			Read the value of atdatas[23].																											
E	R	ATDATA_31			Read the value of atdatas[31].																											

9.7.3.1.15 ITATBCTR2

Address offset: 0xEF0

Integration Test ATB Control Register 2

The Integration Test ATB Control Register 2 enables control of the atreadys and afvalids outputs of the ETB.

Bit number	31	30	29	28	27	26	25	24	23	22	21	20	19	18	17	16	15	14	13	12	11	10	9	8	7	6	5	4	3	2	1	0
ID																												B	A			
Reset 0x00000000	0 0																															
ID	R/W	Field	Value ID	Value	Description																											
A	W	ATREADYS			Set the value of atreadys.																											
B	W	AFVALIDS			Set the value of afvalids.																											

9.7.3.1.16 ITATBCTR1

Address offset: 0xEF4

Integration Test ATB Control Register 1

The Integration Test ATB Control Register 1 contains the value of the atids input to the ETB. This is only valid when atvalids is HIGH.

Bit number	31	30	29	28	27	26	25	24	23	22	21	20	19	18	17	16	15	14	13	12	11	10	9	8	7	6	5	4	3	2	1	0	
ID																												A	A	A	A	A	A
Reset 0x00000000	0 0																																
ID	R/W	Field	Value ID	Value	Description																												
A	R	ATID			Read the value of atids.																												

9.7.3.1.17 ITATBCTRO

Address offset: 0xEF8

Integration Test ATB Control Register 0

The Integration Test ATB Control Register 0 captures the values of the atvalids, atreadys, and atbytes inputs to the ETB. To ensure the integration registers work correctly in a system, the value of atbytes is only valid when atvalids, bit [0], is HIGH.

Bit number	31 30 29 28 27 26 25 24 23 22 21 20 19 18 17 16 15 14 13 12 11 10 9 8 7 6 5 4 3 2 1 0																																	
ID																													C	C			B	A
Reset	0x00000000																																	
	0 0																																	
ID	R/W	Field	Value ID	Value	Description																													
A	R	ATVALID			Read the value of atvalids.																													
B	R	AFREADY			Read the value of afreadys.																													
C	R	ATBYTES			Read the value of atbytes.																													

9.7.3.1.18 ITCTRL

Address offset: 0xF00

Integration Mode Control Register

This register is used to enable topology detection. For more information see the CoreSight Architecture Specification. This register enables the component to switch from a functional mode, the default behavior, to integration mode where the inputs and outputs of the component can be directly controlled for the purpose of integration testing and topology solving. Note: When a device has been in integration mode, it might not function with the original behavior. After performing integration or topology detection, you must reset the system to ensure correct behavior of CoreSight and other connected system components that are affected by the integration or topology detection.

Bit number	31 30 29 28 27 26 25 24 23 22 21 20 19 18 17 16 15 14 13 12 11 10 9 8 7 6 5 4 3 2 1 0																														
ID																															A
Reset	0x00000000																														
	0 0																														
ID	R/W	Field	Value ID	Value	Description																										
A	RW	INTEGRATION_MODE			Allows the component to switch from functional mode to integration mode or back.																										

9.7.3.1.19 CLAIMSET

Address offset: 0xFA0

Claim Tag Set Register

This is used in conjunction with Claim Tag Clear Register, CLAIMCLR. This register forms one half of the Claim Tag value. This location allows individual bits to be set, write, and returns the number of bits that can be set, read.

Bit number	31 30 29 28 27 26 25 24 23 22 21 20 19 18 17 16 15 14 13 12 11 10 9 8 7 6 5 4 3 2 1 0																															
ID																													A	A	A	A
Reset	0x0000000F																															
	0 1 1 1 1																															
ID	R/W	Field	Value ID	Value	Description																											
A	RW	CLAIMSET			This claim tag bit is implemented																											

9.7.3.1.20 CLAIMCLR

Address offset: 0xFA4

Claim Tag Clear Register

This register is used in conjunction with Claim Tag Set Register, CLAIMSET. This register forms one half of the Claim Tag value. This location enables individual bits to be cleared, write, and returns the current Claim Tag value, read.

Bit number	31	30	29	28	27	26	25	24	23	22	21	20	19	18	17	16	15	14	13	12	11	10	9	8	7	6	5	4	3	2	1	0																										
ID																												A	A	A	A																											
Reset	0x00000000																																																									
0	0	0	0	0	0	0	0	0	0	0	0	0	0	0	0	0	0	0	0	0	0	0	0	0	0	0	0	0	0	0	0	0																										
ID	R/W	Field	Value ID	Value	Description																																																					
A	RW	CLAIMCLR			The value present reflects the current setting of the Claim Tag.																																																					

9.7.3.1.21 LAR

Address offset: 0xFB0

Lock Access Register

This is used to enable write access to device registers. External accesses from a debugger (paddrdbg31 = 1) are not subject to the Lock Registers. A debugger does not have to unlock the component in order to write and modify the registers in the component.

Bit number	31	30	29	28	27	26	25	24	23	22	21	20	19	18	17	16	15	14	13	12	11	10	9	8	7	6	5	4	3	2	1	0
ID	A	A	A	A	A	A	A	A	A	A	A	A	A	A	A	A	A	A	A	A	A	A	A	A	A	A	A	A	A	A	A	
Reset	0x00000000																															
0	0	0	0	0	0	0	0	0	0	0	0	0	0	0	0	0	0	0	0	0	0	0	0	0	0	0	0	0	0	0	0	
ID	R/W	Field	Value ID	Value	Description																											
A	W	ACCESS_W			A write of 0xC5ACCE55 enables further write access to this device. A write of any value other than 0xC5ACCE55 will have the affect of removing write access.																											

9.7.3.1.22 LSR

Address offset: 0xFB4

Lock Status Register

This indicates the status of the Lock control mechanism. This lock prevents accidental writes by code under debug. When locked, write access is blocked to all registers, except the Lock Access Register. External accesses from a debugger (paddrdbg31 = 1) are not subject to the Lock Registers. This register reads as 0 when read from an external debugger (paddrdbg31 = 1).

Bit number	31	30	29	28	27	26	25	24	23	22	21	20	19	18	17	16	15	14	13	12	11	10	9	8	7	6	5	4	3	2	1	0																									
ID																												C	B	A																											
Reset	0x00000003																																																								
0	0	0	0	0	0	0	0	0	0	0	0	0	0	0	0	0	0	0	0	0	0	0	0	0	0	0	0	0	0	0	1	1																									
ID	R/W	Field	Value ID	Value	Description																																																				
A	R	LOCKEXIST			Indicates that a lock control mechanism exists for this device. This bit reads as 0 when read from an external debugger (paddrdbg31 = 1) since external debugger accesses are not subject to Lock Registers.																																																				
B	R	LOCKGRANT			Returns the current status of the Lock. This bit reads as 0 when read from an external debugger (paddrdbg31 = 1) since external debugger accesses are not subject to Lock Registers.																																																				
C	R	LOCKTYPE			Indicates if the Lock Access Register (0xFB0) is implemented as 8-bit or 32-bit																																																				

9.7.3.1.23 AUTHSTATUS

Address offset: 0xFB8

Authentication Status Register

Reports what functionality is currently permitted by the authentication interface.

Bit number	31 30 29 28 27 26 25 24 23 22 21 20 19 18 17 16 15 14 13 12 11 10 9 8 7 6 5 4 3 2 1 0																																												
ID																												D	D	C	C	B	B	A	A										
Reset 0x00000000	0 0																																												
ID	R/W	Field	Value ID	Value	Description																																								
A	R	NSID			Indicates the security level for non-secure invasive debug																																								
B	R	NSNID			Indicates the security level for non-secure non-invasive debug																																								
C	R	SID			Indicates the security level for secure invasive debug																																								
D	R	SNID			Indicates the security level for secure non-invasive debug																																								

9.7.3.1.24 DEVID

Address offset: 0xFC8

Device Configuration Register

This register indicates the capabilities of the ETB.

Bit number	31 30 29 28 27 26 25 24 23 22 21 20 19 18 17 16 15 14 13 12 11 10 9 8 7 6 5 4 3 2 1 0																																										
ID																												B	A	A	A	A	A										
Reset 0x00000000	0 0																																										
ID	R/W	Field	Value ID	Value	Description																																						
A	R	EXTMUXNUM			When non-zero this value indicates the type/number of ATB multiplexing present on the input to the ATB.																																						
B	R	RAMCLK			This bit returns 0 on reads indicating that the ETB RAM operates synchronously to atclk.																																						

9.7.3.1.25 DEVTYPE

Address offset: 0xFCC

Device Type Identifier Register

It provides a debugger with information about the component when the Part Number field is not recognized. The debugger can then report this information.

Bit number	31 30 29 28 27 26 25 24 23 22 21 20 19 18 17 16 15 14 13 12 11 10 9 8 7 6 5 4 3 2 1 0																																												
ID																												B	B	B	B	A	A	A	A										
Reset 0x00000021	0 1																																												
ID	R/W	Field	Value ID	Value	Description																																								
A	R	MAJOR_TYPE			Major classification grouping for this debug/trace component																																								
B	R	SUB_TYPE			Sub-classification within the major category																																								

9.7.3.1.26 PERIPHID4

Address offset: 0xFD0

Peripheral ID4 Register

Part of the set of Peripheral Identification registers. Contains part of the designer identity and the memory footprint indicator.

Bit number	31	30	29	28	27	26	25	24	23	22	21	20	19	18	17	16	15	14	13	12	11	10	9	8	7	6	5	4	3	2	1	0																								
ID																									B	B	B	B	A	A	A	A																								
Reset 0x00000004	0																								0	0	0	0	0	0	0	0	0	0	0	0	0	0	0	0	0	0	0	0	0	0	0	0	0	0	0	0	0	1	0	0
ID	R/W	Field	Value ID	Value	Description																																																			
A	R	DES_2			JEDEC continuation code indicating the designer of the component (along with the identity code)																																																			
B	R	SIZE			This is a 4-bit value that indicates the total contiguous size of the memory window used by this component in powers of 2 from the standard 4KB. If a component only requires the standard 4KB then this should read as 0x0, 4KB only, for 8KB set to 0x1, 16KB == 0x2, 32KB == 0x3, and so on.																																																			

9.7.3.1.27 PERIPHID0

Address offset: 0xFE0

Peripheral ID0 Register

Part of the set of Peripheral Identification registers. Contains part of the designer specific part number.

Bit number	31	30	29	28	27	26	25	24	23	22	21	20	19	18	17	16	15	14	13	12	11	10	9	8	7	6	5	4	3	2	1	0																								
ID																									A	A	A	A	A	A	A	A																								
Reset 0x00000007	0																								0	0	0	0	0	0	0	0	0	0	0	0	0	0	0	0	0	0	0	0	0	0	0	0	0	0	0	0	0	1	1	1
ID	R/W	Field	Value ID	Value	Description																																																			
A	R	PART_0			Bits [7:0] of the component's part number. This is selected by the designer of the component.																																																			

9.7.3.1.28 PERIPHID1

Address offset: 0xFE4

Peripheral ID1 Register

Part of the set of Peripheral Identification registers. Contains part of the designer specific part number and part of the designer identity.

Bit number	31	30	29	28	27	26	25	24	23	22	21	20	19	18	17	16	15	14	13	12	11	10	9	8	7	6	5	4	3	2	1	0																							
ID																									B	B	B	B	A	A	A	A																							
Reset 0x000000B9	0																								0	0	0	0	0	0	0	0	0	0	0	0	0	0	0	0	0	0	0	0	0	0	0	1	0	1	1	1	0	0	1
ID	R/W	Field	Value ID	Value	Description																																																		
A	R	PART_1			Bits [11:8] of the component's part number. This is selected by the designer of the component.																																																		
B	R	DES_0			Bits 3:0 of the JEDEC identity code indicating the designer of the component (along with the continuation code)																																																		

9.7.3.1.29 PERIPHID2

Address offset: 0xFE8

Peripheral ID2 Register

Part of the set of Peripheral Identification registers. Contains part of the designer identity and the product revision.

Bit number	31	30	29	28	27	26	25	24	23	22	21	20	19	18	17	16	15	14	13	12	11	10	9	8	7	6	5	4	3	2	1	0
ID																								B	B	B	B	A	A	A	A	
Reset 0x00000090	0	0	0	0	0	0	0	0	0	0	0	0	0	0	0	0	0	0	0	0	0	0	0	0	1	0	0	1	0	0	0	0
ID	R/W	Field	Value ID	Value	Description																											
A	R	PRMBL_1			Contains bits [11:8] of the component identification																											
B	R	CLASS			Class of the component. E. g. ROM table, CoreSight component etc. Constitutes bits [15:12] of the component identification.																											

9.7.3.1.33 COMPID2

Address offset: 0xFF8

Component ID2 Register

A component identification register, that indicates that the identification registers are present.

Bit number	31	30	29	28	27	26	25	24	23	22	21	20	19	18	17	16	15	14	13	12	11	10	9	8	7	6	5	4	3	2	1	0	
ID																								A	A	A	A	A	A	A	A		
Reset 0x00000005	0	0	0	0	0	0	0	0	0	0	0	0	0	0	0	0	0	0	0	0	0	0	0	0	0	0	0	0	0	0	1	0	1
ID	R/W	Field	Value ID	Value	Description																												
A	R	PRMBL_2			Contains bits [23:16] of the component identification																												

9.7.3.1.34 COMPID3

Address offset: 0xFFC

Component ID3 Register

A component identification register, that indicates that the identification registers are present.

Bit number	31	30	29	28	27	26	25	24	23	22	21	20	19	18	17	16	15	14	13	12	11	10	9	8	7	6	5	4	3	2	1	0
ID																								A	A	A	A	A	A	A	A	
Reset 0x000000B1	0	0	0	0	0	0	0	0	0	0	0	0	0	0	0	0	0	0	0	0	0	0	0	0	1	0	1	1	0	0	0	1
ID	R/W	Field	Value ID	Value	Description																											
A	R	PRMBL_3			Contains bits [31:24] of the component identification																											

9.7.4 ETM — Embedded trace macrocell

The ARM embedded trace macrocell implements instruction, data and event tracing.

This document only provides a register-level description of this ARM component. See the [Arm® Embedded Trace Macrocell Architecture Specification](#) for more details

9.7.4.1 Registers

Instances

Instance	Base address	TrustZone			Split access	Description
		Map	Att	DMA		
ETM	0xE0041000	HF	NS	NA	No	ETM

Register overview

Register	Offset	TZ	Description
TRCRPGCTLR	0x004		Enables the trace unit.

Register	Offset	TZ	Description
TRCPROCSCLR	0x008		<p>Controls which PE to trace.</p> <p>Might ignore writes when the trace unit is enabled or not idle.</p> <p>Before writing to this register, ensure that TRCSTATR.IDLE == 1 so that the trace unit can synchronize with the chosen PE.</p> <p>Implemented if TRCIDR3.NUMPROC is greater than zero.</p>
TRCSTATR	0x00C		Idle status bit
TRCCONFIGR	0x010		<p>Controls the tracing options</p> <p>This register must always be programmed as part of trace unit initialization.</p> <p>Might ignore writes when the trace unit is enabled or not idle.</p>
TRCEVENTCTRLOR	0x20		<p>Controls the tracing of arbitrary events.</p> <p>If the selected event occurs a trace element is generated in the trace stream according to the settings in TRCEVENTCTL1R.DATAEN and TRCEVENTCTL1R.INSTEN.</p>
TRCEVENTCTL1R	0x24		<p>Controls the behavior of the events that TRCEVENTCTRLOR selects.</p> <p>This register must always be programmed as part of trace unit initialization.</p> <p>Might ignore writes when the trace unit is enabled or not idle.</p>
TRCSTALLCTRL	0x2C		<p>Enables trace unit functionality that prevents trace unit buffer overflows.</p> <p>Might ignore writes when the trace unit is enabled or not idle.</p> <p>Must be programmed if TRCIDR3.STALLCTL == 1.</p>
TRCTSCTRL	0x30		<p>Controls the insertion of global timestamps in the trace streams.</p> <p>When the selected event is triggered, the trace unit inserts a global timestamp into the trace streams.</p> <p>Might ignore writes when the trace unit is enabled or not idle.</p> <p>Must be programmed if TRCCONFIGR.TS == 1.</p>
TRCSYNCPR	0x34		<p>Controls how often trace synchronization requests occur.</p> <p>Might ignore writes when the trace unit is enabled or not idle.</p> <p>If writes are permitted then the register must be programmed.</p>
TRCCCTRL	0x38		<p>Sets the threshold value for cycle counting.</p> <p>Might ignore writes when the trace unit is enabled or not idle.</p> <p>Must be programmed if TRCCONFIGR.CCI==1.</p>
TRCBCTRL	0x3C		<p>Controls which regions in the memory map are enabled to use branch broadcasting.</p> <p>Might ignore writes when the trace unit is enabled or not idle.</p> <p>Must be programmed if TRCCONFIGR.BB == 1.</p>
TRCTRACEIDR	0x40		<p>Sets the trace ID for instruction trace. If data trace is enabled then it also sets the trace ID for data trace, to (trace ID for instruction trace) + 1.</p> <p>This register must always be programmed as part of trace unit initialization.</p> <p>Might ignore writes when the trace unit is enabled or not idle.</p>
TRCQCTRL	0x44		<p>Controls when Q elements are enabled.</p> <p>Might ignore writes when the trace unit is enabled or not idle.</p> <p>This register must be programmed if it is implemented and TRCCONFIGR.QE is set to any value other than 0b00.</p>
TRCVICTLR	0x080		<p>Controls instruction trace filtering.</p> <p>Might ignore writes when the trace unit is enabled or not idle.</p> <p>Only returns stable data when TRCSTATR.PMSTABLE == 1.</p> <p>Must be programmed, particularly to set the value of the SSSTATUS bit, which sets the state of the start/stop logic.</p>

Register	Offset	TZ	Description
TRCVIIECTLR	0x084		ViewInst exclude control. Might ignore writes when the trace unit is enabled or not idle. This register must be programmed when one or more address comparators are implemented.
TRCVISSCTLR	0x088		Use this to set, or read, the single address comparators that control the ViewInst start/stop logic. The start/stop logic is active for an instruction which causes a start and remains active up to and including an instruction which causes a stop, and then the start/stop logic becomes inactive. Might ignore writes when the trace unit is enabled or not idle. If implemented then this register must be programmed.
TRCVIPCSCTLR	0x08C		Use this to set, or read, which PE comparator inputs can control the ViewInst start/stop logic. Might ignore writes when the trace unit is enabled or not idle. If implemented then this register must be programmed.
TRCVDCTLR	0x0A0		Controls data trace filtering. Might ignore writes when the trace unit is enabled or not idle. This register must be programmed when data tracing is enabled, that is, when either TRCCONFIGR.DA == 1 or TRCCONFIGR.DV == 1.
TRCVDSACCTLR	0x0A4		ViewData include / exclude control. Might ignore writes when the trace unit is enabled or not idle. This register must be programmed when one or more address comparators are implemented.
TRCVDARCCTLR	0x0A8		ViewData include / exclude control. Might ignore writes when the trace unit is enabled or not idle. This register must be programmed when one or more address comparators are implemented.
TRCSEQEVR[n]	0x100		Moves the sequencer state according to programmed events. Might ignore writes when the trace unit is enabled or not idle. When the sequencer is used, all sequencer state transitions must be programmed with a valid event.
TRCSEQRSTEVR	0x118		Moves the sequencer to state 0 when a programmed event occurs. Might ignore writes when the trace unit is enabled or not idle. When the sequencer is used, all sequencer state transitions must be programmed with a valid event.
TRCSEQSTR	0x11C		Use this to set, or read, the sequencer state. Might ignore writes when the trace unit is enabled or not idle. Only returns stable data when TRCSTATR.PMSTABLE == 1. When the sequencer is used, all sequencer state transitions must be programmed with a valid event.
TRCEXTINSELR	0x120		Use this to set, or read, which external inputs are resources to the trace unit. Might ignore writes when the trace unit is enabled or not idle. Only returns stable data when TRCSTATR.PMSTABLE == 1. When the sequencer is used, all sequencer state transitions must be programmed with a valid event.
TRCNRRLDVR[n]	0x140		This sets or returns the reload count value for counter n. Might ignore writes when the trace unit is enabled or not idle.
TRCNTCTLR[n]	0x150		Controls the operation of counter n. Might ignore writes when the trace unit is enabled or not idle.

Register	Offset	TZ	Description
TRCNTVR[n]	0x160		This sets or returns the value of counter n. The count value is only stable when TRCSTATR.PMSTABLE == 1. If software uses counter n then it must write to this register to set the initial counter value. Might ignore writes when the trace unit is enabled or not idle.
TRCRSCTLR[n]	0x200		Controls the selection of the resources in the trace unit. Might ignore writes when the trace unit is enabled or not idle. If software selects a non-implemented resource then CONSTRAINED UNPREDICTABLE behavior of the resource selector occurs, so the resource selector might fire unexpectedly or might not fire. Reads of the TRCRSCTLRn might return UNKNOWN.
TRCSSCCRO	0x280		Controls the single-shot comparator.
TRCSSCSRO	0x2A0		Indicates the status of the single-shot comparators. TRCSSCSRO is sensitive to instruction addresses.
TRCSSPCICRO	0x2C0		Selects the processor comparator inputs for Single-shot control.
TRCPDCR	0x310		Controls the single-shot comparator.
TRCPDSR	0x314		Indicates the power down status of the ETM.
TRCITATBIDR	0xEE4		Sets the state of output pins.
TRCITIATBINR	0xEF4		Reads the state of the input pins.
TRCITIATBOUTr	0xEFC		Sets the state of the output pins.
TRCITCTRL	0xF00		Enables topology detection or integration testing, by putting ETM-M33 into integration mode.
TRCLAIMSET	0xFA0		Sets bits in the claim tag and determines the number of claim tag bits implemented.
TRCLAIMCLR	0xFA4		Clears bits in the claim tag and determines the current value of the claim tag.
TRCAUTHSTATUS	0xFB8		Indicates the current level of tracing permitted by the system
TRCDEVARCH	0xFBC		The TRCDEVARCH identifies ETM-M33 as an ETMv4.2 component
TRCDEVTYPE	0xFCC		Controls the single-shot comparator.
TRCPIDR[n]	0xFD0		Coresight peripheral identification registers.
TRCCIDR[n]	0xFF0		Coresight component identification registers.

9.7.4.1.1 TRCPRGCTLR

Address offset: 0x004

Enables the trace unit.

Bit number	31 30 29 28 27 26 25 24 23 22 21 20 19 18 17 16 15 14 13 12 11 10 9 8 7 6 5 4 3 2 1 0																															
ID	A																															
Reset	0x00000000																															
0	0	0	0	0	0	0	0	0	0	0	0	0	0	0	0	0	0	0	0	0	0	0	0	0	0	0	0	0	0	0	0	0
ID	R/W	Field	Value ID	Value	Description																											
A	RW	EN			Trace unit enable bit																											
			Disabled	0	The trace unit is disabled. All trace resources are inactive and no trace is generated.																											
			Enabled	1	The trace unit is enabled.																											

9.7.4.1.2 TRCPROCSELR

Address offset: 0x008

Controls which PE to trace.

Might ignore writes when the trace unit is enabled or not idle.

Before writing to this register, ensure that TRCSTATR.IDLE == 1 so that the trace unit can synchronize with the chosen PE.

Implemented if TRCIDR3.NUMPROC is greater than zero.

Bit number	31	30	29	28	27	26	25	24	23	22	21	20	19	18	17	16	15	14	13	12	11	10	9	8	7	6	5	4	3	2	1	0	
ID																													A	A	A	A	A
Reset 0x00000000	0 0																																
ID	R/W	Field	Value ID	Value	Description																												
A	RW	PROCSEL			PE select bits that select the PE to trace.																												

9.7.4.1.3 TRCSTATR

Address offset: 0x00C

Idle status bit

Bit number	31	30	29	28	27	26	25	24	23	22	21	20	19	18	17	16	15	14	13	12	11	10	9	8	7	6	5	4	3	2	1	0
ID																													B	A		
Reset 0x00000000	0 0																															
ID	R/W	Field	Value ID	Value	Description																											
A	RW	IDLE			Trace unit enable bit																											
			NotIdle	0	The trace unit is not idle.																											
			Idle	1	The trace unit is idle.																											
B	RW	PMSTABLE			Programmers' model stable bit																											
			NotStable	0	The programmers' model is not stable.																											
			Stable	1	The programmers' model is stable.																											

9.7.4.1.4 TRCCONFIGR

Address offset: 0x010

Controls the tracing options

This register must always be programmed as part of trace unit initialization.

Might ignore writes when the trace unit is enabled or not idle.

Bit number	31	30	29	28	27	26	25	24	23	22	21	20	19	18	17	16	15	14	13	12	11	10	9	8	7	6	5	4	3	2	1	0																											
ID																													M	L	K	J	J	I	H	G	G	G	F	E																			
Reset 0x00000000	0 0																																																										
ID	R/W	Field	Value ID	Value	Description																																																						
A	RW	LOADASPOINST			Instruction P0 load field. This field controls whether load instructions are traced as P0 instructions.																																																						
			No	0	Do not trace load instructions as P0 instructions.																																																						
			Yes	1	Trace load instructions as P0 instructions.																																																						
B	RW	STOREASPOINST			Instruction P0 field. This field controls whether store instructions are traced as P0 instructions.																																																						
			No	0	Do not trace store instructions as P0 instructions.																																																						
			Yes	1	Trace store instructions as P0 instructions.																																																						
C	RW	BB			Branch broadcast mode bit.																																																						
			Disabled	0	Branch broadcast mode is disabled.																																																						
			Enabled	1	Branch broadcast mode is enabled.																																																						
D	RW	CCI			Cycle counting instruction trace bit.																																																						
			Disabled	0	Cycle counting in the instruction trace is disabled.																																																						
			Enabled	1	Cycle counting in the instruction trace is enabled.																																																						
E	RW	CID			Context ID tracing bit.																																																						
			Disabled	0	Context ID tracing is disabled.																																																						
			Enabled	1	Context ID tracing is enabled.																																																						
F	RW	VMID			Virtual context identifier tracing bit.																																																						
			Disabled	0	Virtual context identifier tracing is disabled.																																																						

Bit number		31 30 29 28 27 26 25 24 23 22 21 20 19 18 17 16 15 14 13 12 11 10 9 8 7 6 5 4 3 2 1 0																															
ID		M L K J J I H G G G F E D C B A																															
Reset 0x00000000		0 0																															
ID	R/W	Field	Value ID	Value	Description																												
			Enabled	1	Virtual context identifier tracing is enabled.																												
G	RW	COND			Conditional instruction tracing bit.																												
			Disabled	0	Conditional instruction tracing is disabled.																												
			LoadOnly	1	Conditional load instructions are traced.																												
			StoreOnly	2	Conditional store instructions are traced.																												
			LoadAndStore	3	Conditional load and store instructions are traced.																												
			All	7	All conditional instructions are traced.																												
H	RW	TS			Global timestamp tracing bit.																												
			Disabled	0	Global timestamp tracing is disabled.																												
			Enabled	1	Global timestamp tracing is enabled.																												
I	RW	RS			Return stack enable bit.																												
			Disabled	0	Return stack is disabled.																												
			Enabled	1	Return stack is enabled.																												
J	RW	QE			Q element enable field.																												
			Disabled	0	Q elements are disabled.																												
			OnlyWithoutInstCou	1	Q elements with instruction counts are enabled. Q elements without instruction counts are disabled.																												
			Enabled	3	Q elements with and without instruction counts are enabled.																												
K	RW	VMIDOPT			Control bit to select the Virtual context identifier value used by the trace unit, both for trace generation and in the Virtual context identifier comparators.																												
			VTTBR_EL2	0	VTTBR_EL2.VMID is used. If the trace unit supports a Virtual context identifier larger than the VTTBR_EL2.VMID, the upper unused bits are always zero. If the trace unit supports a Virtual context identifier larger than 8 bits and if the VTCR_EL2.VS bit forces use of an 8-bit Virtual context identifier, bits [15:8] of the trace unit Virtual context identifier are always zero.																												
			CONTEXTIDR_EL2	1	CONTEXTIDR_EL2 is used.																												
L	RW	DA			Data address tracing bit.																												
			Disabled	0	Data address tracing is disabled.																												
			Enabled	1	Data address tracing is enabled.																												
M	RW	DV			Data value tracing bit.																												
			Disabled	0	Data value tracing is disabled.																												
			Enabled	1	Data value tracing is enabled.																												

9.7.4.1.5 TRCEVENTCTL0R

Address offset: 0x20

Controls the tracing of arbitrary events.

If the selected event occurs a trace element is generated in the trace stream according to the settings in TRCEVENTCTL1R.DATAEN and TRCEVENTCTL1R.INSTEN.

Bit number		31 30 29 28 27 26 25 24 23 22 21 20 19 18 17 16 15 14 13 12 11 10 9 8 7 6 5 4 3 2 1 0																															
ID		A A A A A A A A																															
Reset 0x00000000		0 0																															
ID	R/W	Field	Value ID	Value	Description																												
A	RW	EVENT		[0:255]	Select which event should generate trace elements.																												

9.7.4.1.6 TRCEVENTCTL1R

Address offset: 0x24

Controls the behavior of the events that TRCEVENTCTL0R selects.

This register must always be programmed as part of trace unit initialization.

Might ignore writes when the trace unit is enabled or not idle.

Bit number	31 30 29 28 27 26 25 24 23 22 21 20 19 18 17 16 15 14 13 12 11 10 9 8 7 6 5 4 3 2 1 0																																				
ID																G	F																E	D	C	B	A
Reset 0x00000000	0 0																																				
ID	R/W	Field	Value ID	Value	Description																																
A-D	RW	INSTEN[i] (i=0..3)			Instruction event enable field.																																
			Disabled	0	The trace unit does not generate an Event element.																																
			Enabled	1	The trace unit generates an Event element for event i, in the instruction trace stream.																																
E	RW	DATAEN			Data event enable bit.																																
			Disabled	0	The trace unit does not generate an Event element if event 0 occurs.																																
			Enabled	1	The trace unit generates an Event element in the data trace stream if event 0 occurs.																																
F	RW	ATB			AMBA Trace Bus (ATB) trigger enable bit.																																
			Disabled	0	ATB trigger is disabled.																																
			Enabled	1	ATB trigger is enabled. If a CoreSight ATB interface is implemented then when event 0 occurs the trace unit generates an ATB event.																																
G	RW	LPOVERRIDE			Low-power state behavior override bit. Controls how a trace unit behaves in low-power state.																																
			Disabled	0	Trace unit low-power state behavior is not affected. That is, the trace unit is enabled to enter low-power state.																																
			Enabled	1	Trace unit low-power state behavior is overridden. That is, entry to a low-power state does not affect the trace unit resources or trace generation.																																

9.7.4.1.7 TRCSTALLCTLR

Address offset: 0x2C

Enables trace unit functionality that prevents trace unit buffer overflows.

Might ignore writes when the trace unit is enabled or not idle.

Must be programmed if TRCIDR3.STALLCTL == 1.

Bit number	31 30 29 28 27 26 25 24 23 22 21 20 19 18 17 16 15 14 13 12 11 10 9 8 7 6 5 4 3 2 1 0																																						
ID																G	F	E	D	C	B																A	A	A
Reset 0x00000000	0 0																																						
ID	R/W	Field	Value ID	Value	Description																																		
A	RW	LEVEL		[15:0]	Threshold level field.																																		
					If LEVEL is nonzero then a trace unit might suppress the generation of:																																		
					Global timestamps in the instruction trace stream and the data trace stream.																																		
					Cycle counting in the instruction trace stream, although the cumulative cycle count remains correct.																																		
			Min	0	Zero invasion. This setting has a greater risk of a FIFO overflow																																		
Max	15	Maximum invasion occurs but there is less risk of a FIFO overflow.																																					

Bit number	31 30 29 28 27 26 25 24 23 22 21 20 19 18 17 16 15 14 13 12 11 10 9 8 7 6 5 4 3 2 1 0																																																		
ID																												G	F	E	D	C	B															A	A	A	A
Reset 0x00000000	0 0																																																		
ID	R/W	Field	Value ID	Value	Description																																														
B	RW	ISTALL			Instruction stall bit. Controls if a trace unit can stall the PE when the instruction trace buffer space is less than LEVEL.																																														
			Disabled	0	The trace unit must not stall the PE.																																														
			Enabled	1	The trace unit can stall the PE.																																														
C	RW	DSTALL			Data stall bit. Controls if a trace unit can stall the PE when the data trace buffer space is less than LEVEL.																																														
			Disabled	0	The trace unit must not stall the PE.																																														
			Enabled	1	The trace unit can stall the PE.																																														
D	RW	INSTPRIORITY			Prioritize instruction trace bit. Controls if a trace unit can prioritize instruction trace when the instruction trace buffer space is less than LEVEL.																																														
			Disabled	0	The trace unit must not prioritize instruction trace.																																														
			Enabled	1	The trace unit can prioritize instruction trace. A trace unit might prioritize instruction trace by preventing output of data trace, or other means which ensure that the instruction trace has a higher priority than the data trace.																																														
E	RW	DATADISCARDLOAD			Data discard field. Controls if a trace unit can discard data trace elements on a load when the data trace buffer space is less than LEVEL.																																														
			Disabled	0	The trace unit must not discard any data trace elements.																																														
			Enabled	1	The trace unit can discard P1 and P2 elements associated with data loads.																																														
F	RW	DATADISCARDSTORE			Data discard field. Controls if a trace unit can discard data trace elements on a store when the data trace buffer space is less than LEVEL.																																														
			Disabled	0	The trace unit must not discard any data trace elements.																																														
			Enabled	1	The trace unit can discard P1 and P2 elements associated with data stores.																																														
G	RW	NOOVERFLOW			Trace overflow prevention bit.																																														
			Disabled	0	Trace overflow prevention is disabled.																																														
			Enabled	1	Trace overflow prevention is enabled. This might cause a significant performance impact.																																														

9.7.4.1.8 TRCTSCTLR

Address offset: 0x30

Controls the insertion of global timestamps in the trace streams.

When the selected event is triggered, the trace unit inserts a global timestamp into the trace streams.

Might ignore writes when the trace unit is enabled or not idle.

Must be programmed if TRCCONFIGR.TS == 1.

Bit number	31 30 29 28 27 26 25 24 23 22 21 20 19 18 17 16 15 14 13 12 11 10 9 8 7 6 5 4 3 2 1 0																																																
ID																												A	A	A	A	A	A	A	A														
Reset 0x00000000	0 0																																																
ID	R/W	Field	Value ID	Value	Description																																												
A	RW	EVENT		[0:255]	Select which event should generate time stamps.																																												

9.7.4.1.9 TRCSYNCPR

Address offset: 0x34

Controls how often trace synchronization requests occur.

Might ignore writes when the trace unit is enabled or not idle.

If writes are permitted then the register must be programmed.

Bit number	31	30	29	28	27	26	25	24	23	22	21	20	19	18	17	16	15	14	13	12	11	10	9	8	7	6	5	4	3	2	1	0
ID	A A A A A A A																															
Reset 0x00000000	0 0																															
ID	R/W	Field	Value ID	Value	Description																											
A	RW	TRACEID			Trace ID field. Sets the trace ID value for instruction trace. Bit[0] must be zero if data trace is enabled. If data trace is enabled then a trace unit sets the trace ID for data trace, to TRACEID+1.																											

9.7.4.1.13 TRCQCTLR

Address offset: 0x44

Controls when Q elements are enabled.

Might ignore writes when the trace unit is enabled or not idle.

This register must be programmed if it is implemented and TRCCONFIGR.QE is set to any value other than 0b00.

Bit number	31	30	29	28	27	26	25	24	23	22	21	20	19	18	17	16	15	14	13	12	11	10	9	8	7	6	5	4	3	2	1	0
ID	I H G F E D C B A																															
Reset 0x00000000	0 0																															
ID	R/W	Field	Value ID	Value	Description																											
A-H	RW	RANGE[i] (i=0..7)			Specifies the address range comparators to be used for controlling Q elements.																											
			Disabled	0	Address range comparator i is disabled.																											
			Enabled	1	Address range comparator i is selected for use.																											
I	RW	MODE			Selects whether the address range comparators selected by the RANGE field indicate address ranges where the trace unit is permitted to generate Q elements or address ranges where the trace unit is not permitted to generate Q elements:																											
			Exclude	0	Exclude mode. The address range comparators selected by the RANGE field indicate address ranges where the trace unit cannot generate Q elements. If no ranges are selected, Q elements are permitted across the entire memory map.																											
			Include	1	Include mode. The address range comparators selected by the RANGE field indicate address ranges where the trace unit can generate Q elements. If all the implemented bits in RANGE are set to 0 then Q elements are disabled.																											

9.7.4.1.14 TRCVICTLR

Address offset: 0x080

Controls instruction trace filtering.

Might ignore writes when the trace unit is enabled or not idle.

Only returns stable data when TRCSTATR.PMSTABLE == 1.

Must be programmed, particularly to set the value of the SSSTATUS bit, which sets the state of the start/stop logic.

Bit number	31	30	29	28	27	26	25	24	23	22	21	20	19	18	17	16	15	14	13	12	11	10	9	8	7	6	5	4	3	2	1	0
ID	L K J I H G F E										D C B			A A A A A																		
Reset 0x00000000	0 0																															
ID	R/W	Field	Value ID	Value	Description																											
A	RW	EVENT_SEL			Select which resource number should be filtered.																											

Bit number	31 30 29 28 27 26 25 24 23 22 21 20 19 18 17 16 15 14 13 12 11 10 9 8 7 6 5 4 3 2 1 0																														
ID	L K J I H G F E															D C B			A A A A												
Reset 0x00000000	0 0																														
ID	R/W	Field	Value ID	Value	Description																										
			Disabled	0	This event is not filtered.																										
			Enabled	1	This event is filtered.																										
B	RW	SSSTATUS			When TRCIDR4.NUMACPAIRS > 0 or TRCIDR4.NUMPC > 0, this bit returns the status of the start/stop logic.																										
			Stopped	0	The start/stop logic is in the stopped state.																										
			Started	1	The start/stop logic is in the started state.																										
C	RW	TRCRESET			Controls whether a trace unit must trace a Reset exception.																										
			Disabled	0	The trace unit does not trace a Reset exception unless it traces the exception or instruction immediately prior to the Reset exception.																										
			Enabled	1	The trace unit always traces a Reset exception.																										
D	RW	TRCERR			When TRCIDR3.TRCERR==1, this bit controls whether a trace unit must trace a System error exception.																										
			Disabled	0	The trace unit does not trace a System error exception unless it traces the exception or instruction immediately prior to the System error exception.																										
			Enabled	1	The trace unit always traces a System error exception, regardless of the value of ViewInst.																										
E-H	RW	EXLEVEL[i]_S (i=0..3)			In Secure state, each bit controls whether instruction tracing is enabled for the corresponding Exception level i.																										
			Disabled	1	The trace unit does not generate instruction trace, in Secure state, for Exception level i.																										
			Enabled	0	The trace unit generates instruction trace, in Secure state, for Exception level i.																										
I-L	RW	EXLEVEL[i]_NS (i=0..3)			In Non-secure state, each bit controls whether instruction tracing is enabled for the corresponding Exception level i.																										
			Disabled	1	The trace unit does not generate instruction trace, in Non-secure state, for Exception level i.																										
			Enabled	0	The trace unit generates instruction trace, in Non-secure state, for Exception level i.																										

9.7.4.1.15 TRCVIIECTLR

Address offset: 0x084

ViewInst exclude control.

Might ignore writes when the trace unit is enabled or not idle.

This register must be programmed when one or more address comparators are implemented.

Bit number	31 30 29 28 27 26 25 24 23 22 21 20 19 18 17 16 15 14 13 12 11 10 9 8 7 6 5 4 3 2 1 0																														
ID	P O N M L K J I															H G F E D C B A															
Reset	0x00000000																														
ID	R/W	Field	Value ID	Value	Description																										
A-H	RW	INCLUDE[i] (i=0..7)			Include range field. Selects which address range comparator pairs are in use with ViewInst include control.																										
			Disabled	0	The address range that address range comparator pair i defines, is not selected for ViewInst include control.																										
			Enabled	1	The address range that address range comparator pair i defines, is selected for ViewInst include control.																										
I-P	RW	EXCLUDE[i] (i=0..7)			Exclude range field. Selects which address range comparator pairs are in use with ViewInst exclude control.																										
			Disabled	0	The address range that address range comparator pair i defines, is not selected for ViewInst exclude control.																										
			Enabled	1	The address range that address range comparator pair i defines, is selected for ViewInst exclude control.																										

9.7.4.1.16 TRCVISSCTLR

Address offset: 0x088

Use this to set, or read, the single address comparators that control the ViewInst start/stop logic. The start/stop logic is active for an instruction which causes a start and remains active up to and including an instruction which causes a stop, and then the start/stop logic becomes inactive.

Might ignore writes when the trace unit is enabled or not idle.

If implemented then this register must be programmed.

Bit number	31 30 29 28 27 26 25 24 23 22 21 20 19 18 17 16 15 14 13 12 11 10 9 8 7 6 5 4 3 2 1 0																														
ID	P O N M L K J I															H G F E D C B A															
Reset	0x00000000																														
ID	R/W	Field	Value ID	Value	Description																										
A-H	RW	START[i] (i=0..7)			Selects which single address comparators are in use with ViewInst start/stop control, for the purpose of starting trace.																										
			Disabled	0	The single address comparator i, is not selected as a start resource.																										
			Enabled	1	The single address comparator i, is selected as a start resource.																										
I-P	RW	STOP[i] (i=0..7)			Selects which single address comparators are in use with ViewInst start/stop control, for the purpose of stopping trace																										
			Disabled	0	The single address comparator i, is not selected as a stop resource.																										
			Enabled	1	The single address comparator i, is selected as a stop resource.																										

9.7.4.1.17 TRCVIPCSSCTLR

Address offset: 0x08C

Use this to set, or read, which PE comparator inputs can control the ViewInst start/stop logic.

Might ignore writes when the trace unit is enabled or not idle.

If implemented then this register must be programmed.

Bit number	31	30	29	28	27	26	25	24	23	22	21	20	19	18	17	16	15	14	13	12	11	10	9	8	7	6	5	4	3	2	1	0				
ID											P	O	N	M	L	K	J	I											H	G	F	E	D	C	B	A
Reset	0x00000000																																			
Reset	0 0																																			
ID	R/W	Field	Value ID	Value	Description																															
A-H	RW	START[i] (i=0..7)			Selects which PE comparator inputs are in use with ViewInst start/stop control, for the purpose of starting trace																															
			Disabled	0	The single PE comparator input i, is not selected as a start resource.																															
			Enabled	1	The single PE comparator input i, is selected as a start resource.																															
I-P	RW	STOP[i] (i=0..7)			Selects which PE comparator inputs are in use with ViewInst start/stop control, for the purpose of stopping trace.																															
			Disabled	0	The single PE comparator input i, is not selected as a stop resource.																															
			Enabled	1	The single PE comparator input i, is selected as a stop resource.																															

9.7.4.1.18 TRCVDCTLR

Address offset: 0x0A0

Controls data trace filtering.

Might ignore writes when the trace unit is enabled or not idle.

This register must be programmed when data tracing is enabled, that is, when either TRCCONFIGR.DA == 1 or TRCCONFIGR.DV == 1.

Bit number	31	30	29	28	27	26	25	24	23	22	21	20	19	18	17	16	15	14	13	12	11	10	9	8	7	6	5	4	3	2	1	0	
ID																					L	K	J	I	I	H	G	F	E	D	C	B	A
Reset	0x00000000																																
Reset	0 0																																
ID	R/W	Field	Value ID	Value	Description																												
A-H	RW	EVENT[i] (i=0..7)			Event unit enable bit.																												
			Disabled	0	The trace event is not selected for trace filtering.																												
			Enabled	1	The trace event is selected for trace filtering.																												
I	RW	SPREL			Controls whether a trace unit traces data for transfers that are relative to the Stack Pointer (SP).																												
			Enabled	0	The trace unit does not affect the tracing of SP-relative transfers.																												
			DataOnly	2	The trace unit does not trace the address portion of SP-relative transfers. If data value tracing is enabled then the trace unit generates a P1 data address element.																												
			Disabled	3	The trace unit does not trace the address or value portions of SP-relative transfers.																												
J	RW	PCREL			Controls whether a trace unit traces data for transfers that are relative to the Program Counter (PC).																												
			Enabled	0	The trace unit does not affect the tracing of PC-relative transfers.																												
			Disabled	1	The trace unit does not trace the address or value portions of PC-relative transfers.																												
K	RW	TBI			Controls which information a trace unit populates in bits[63:56] of the data address.																												
			SignExtend	0	The trace unit assigns bits[63:56] to have the same value as bit[55] of the data address, that is, it sign-extends the value.																												
			Copy	1	The trace unit assigns bits[63:56] to have the same value as bits[63:56] of the data address.																												
L	RW	TRCEXDATA			Controls the tracing of data transfers for exceptions and exception returns on Armv6-M, Armv7-M, and Armv8-M PEs.																												
			Disabled	0	Exception and exception return data transfers are not traced.																												
			Enabled	1	Exception and exception return data transfers are traced if the other aspects of ViewData indicate that the data transfers must be traced.																												

9.7.4.1.19 TRCVDSACCTLR

Address offset: 0x0A4

ViewData include / exclude control.

Might ignore writes when the trace unit is enabled or not idle.

This register must be programmed when one or more address comparators are implemented.

Bit number	31 30 29 28 27 26 25 24 23 22 21 20 19 18 17 16 15 14 13 12 11 10 9 8 7 6 5 4 3 2 1 0																															
ID	P O N M L K J I															H G F E D C B A																
Reset 0x00000000		0 0																														
ID	R/W	Field	Value ID	Value	Description																											
A-H	RW	INCLUDE[i] (i=0..7)	Disabled	0	Selects which single address comparators are in use with ViewData include control. The single address comparator i, is not selected for ViewData include control.																											
			Enabled	1	The single address comparator i, is selected for ViewData include control.																											
I-P	RW	EXCLUDE[i] (i=0..7)	Disabled	0	Selects which single address comparators are in use with ViewData exclude control. The single address comparator i, is not selected for ViewData exclude control.																											
			Enabled	1	The single address comparator i, s selected for ViewData exclude control.																											

9.7.4.1.20 TRCVDARCCTLR

Address offset: 0x0A8

ViewData include / exclude control.

Might ignore writes when the trace unit is enabled or not idle.

This register must be programmed when one or more address comparators are implemented.

Bit number	31 30 29 28 27 26 25 24 23 22 21 20 19 18 17 16 15 14 13 12 11 10 9 8 7 6 5 4 3 2 1 0																															
ID	P O N M L K J I															H G F E D C B A																
Reset 0x00000000		0 0																														
ID	R/W	Field	Value ID	Value	Description																											
A-H	RW	INCLUDE[i] (i=0..7)	Disabled	0	Include range field. Selects which address range comparator pairs are in use with ViewData include control. The address range that address range comparator i defines, is not selected for ViewData include control.																											
			Enabled	1	The address range that address range comparator i defines, is selected for ViewData include control.																											
I-P	RW	EXCLUDE[i] (i=0..7)	Disabled	0	Exclude range field. Selects which address range comparator pairs are in use with ViewData exclude control. The address range that address range comparator i defines, is not selected for ViewData exclude control.																											
			Enabled	1	The address range that address range comparator i defines, s selected for ViewData exclude control.																											

9.7.4.1.21 TRCSEQEVR[n] (n=0..2)

Address offset: 0x100 + (n × 0x4)

Moves the sequencer state according to programmed events.

Might ignore writes when the trace unit is enabled or not idle.

When the sequencer is used, all sequencer state transitions must be programmed with a valid event.

Bit number	31 30 29 28 27 26 25 24 23 22 21 20 19 18 17 16 15 14 13 12 11 10 9 8 7 6 5 4 3 2 1 0																														
ID	P O N M L K J I H G F E D C B A																														
Reset 0x00000000	0 0																														
ID	R/W	Field	Value ID	Value	Description																										
A-H	RW	F[i] (i=0..7)	Disabled	0	Forward field. The trace event does not affect the sequencer.																										
			Enabled	1	When the event occurs then the sequencer state moves from state n to state n+1.																										
I-P	RW	B[i] (i=0..7)	Disabled	0	Backward field. The trace event does not affect the sequencer.																										
			Enabled	1	When the event occurs then the sequencer state moves from state n+1 to state n.																										

9.7.4.1.22 TRCSEQRSTEV

Address offset: 0x118

Moves the sequencer to state 0 when a programmed event occurs.

Might ignore writes when the trace unit is enabled or not idle.

When the sequencer is used, all sequencer state transitions must be programmed with a valid event.

Bit number	31 30 29 28 27 26 25 24 23 22 21 20 19 18 17 16 15 14 13 12 11 10 9 8 7 6 5 4 3 2 1 0																														
ID	A A A A A A A A																														
Reset 0x00000000	0 0																														
ID	R/W	Field	Value ID	Value	Description																										
A	RW	EVENT		[0:255]	Select which event should reset the sequencer.																										

9.7.4.1.23 TRCSEQSTR

Address offset: 0x11C

Use this to set, or read, the sequencer state.

Might ignore writes when the trace unit is enabled or not idle.

Only returns stable data when TRCSTATR.PMSTABLE == 1.

When the sequencer is used, all sequencer state transitions must be programmed with a valid event.

Bit number	31 30 29 28 27 26 25 24 23 22 21 20 19 18 17 16 15 14 13 12 11 10 9 8 7 6 5 4 3 2 1 0																														
ID	A A																														
Reset 0x00000000	0 0																														
ID	R/W	Field	Value ID	Value	Description																										
A	RW	STATE			Sets or returns the state of the sequencer.																										
			State0	0	The sequencer is in state 0.																										
			State1	1	The sequencer is in state 1.																										
			State2	2	The sequencer is in state 2.																										
			State3	3	The sequencer is in state 3.																										

9.7.4.1.24 TRCEXTINSEL

Address offset: 0x120

Use this to set, or read, which external inputs are resources to the trace unit.

Might ignore writes when the trace unit is enabled or not idle.

Only returns stable data when TRCSTATR.PMSTABLE == 1.

When the sequencer is used, all sequencer state transitions must be programmed with a valid event.

Bit number	31	30	29	28	27	26	25	24	23	22	21	20	19	18	17	16	15	14	13	12	11	10	9	8	7	6	5	4	3	2	1	0
ID	D	D	D	D	D	D	D	D	C	C	C	C	C	C	C	B	B	B	B	B	B	B	B	A	A	A	A	A	A	A	A	A
Reset 0x00000000	0	0	0	0	0	0	0	0	0	0	0	0	0	0	0	0	0	0	0	0	0	0	0	0	0	0	0	0	0	0	0	0
ID	R/W	Field	Value ID	Value	Description																											
A-D	RW	SEL[i] (i=0..3)		[0:255]	Each field in this collection selects an external input as a resource for the trace unit.																											

9.7.4.1.25 TRCCNTRLDVR[n] (n=0..3)

Address offset: 0x140 + (n × 0x4)

This sets or returns the reload count value for counter n.

Might ignore writes when the trace unit is enabled or not idle.

Bit number	31	30	29	28	27	26	25	24	23	22	21	20	19	18	17	16	15	14	13	12	11	10	9	8	7	6	5	4	3	2	1	0		
ID																										A	A	A	A	A	A	A	A	A
Reset 0x00000000	0	0	0	0	0	0	0	0	0	0	0	0	0	0	0	0	0	0	0	0	0	0	0	0	0	0	0	0	0	0	0	0		
ID	R/W	Field	Value ID	Value	Description																													
A	RW	VALUE		[0:65535]	Contains the reload value for counter n. When a reload event occurs for counter n then the trace unit copies the VALUE _n field into counter n.																													

9.7.4.1.26 TRCCNTCTLR[n] (n=0..3)

Address offset: 0x150 + (n × 0x4)

Controls the operation of counter n.

Might ignore writes when the trace unit is enabled or not idle.

Bit number	31	30	29	28	27	26	25	24	23	22	21	20	19	18	17	16	15	14	13	12	11	10	9	8	7	6	5	4	3	2	1	0																			
ID																																		D	C	B	B	B	B	B	B	B	A	A	A	A	A	A	A		
Reset 0x00000000	0	0	0	0	0	0	0	0	0	0	0	0	0	0	0	0	0	0	0	0	0	0	0	0	0	0	0	0	0	0	0	0	0	0	0	0	0	0	0	0	0	0	0	0	0	0	0	0	0	0	0
ID	R/W	Field	Value ID	Value	Description																																														
A	RW	CNTEVENT		[0:255]	Selects an event, that when it occurs causes counter n to decrement.																																														
B	RW	RLDEVENT		[0:255]	Selects an event, that when it occurs causes a reload event for counter n.																																														
C	RW	RLDSELF			Controls whether a reload event occurs for counter n, when counter n reaches zero.																																														
			Disabled	0	The counter is in Normal mode.																																														
			Enabled	1	The counter is in Self-reload mode.																																														
D	RW	CNTCHAIN			For TRCCNTCTLR3 and TRCCNTCTLR1, this bit controls whether counter n decrements when a reload event occurs for counter n-1.																																														
			Disabled	0	Counter n does not decrement when a reload event for counter n-1 occurs.																																														
			Enabled	1	Counter n decrements when a reload event for counter n-1 occurs. This concatenates counter n and counter n-1, to provide a larger count value.																																														

9.7.4.1.27 TRCCNTVR[n] (n=0..3)

Address offset: 0x160 + (n × 0x4)

This sets or returns the value of counter n.

The count value is only stable when TRCSTATR.PMSTABLE == 1.

If software uses counter n then it must write to this register to set the initial counter value.

Might ignore writes when the trace unit is enabled or not idle.

Bit number	31	30	29	28	27	26	25	24	23	22	21	20	19	18	17	16	15	14	13	12	11	10	9	8	7	6	5	4	3	2	1	0
ID	A A																															
Reset 0x00000000	0 0																															
ID	R/W	Field	Value ID	Value	Description																											
A	RW	VALUE		[0:65535]	Contains the count value of counter n.																											

9.7.4.1.28 TRCRSCTLR[n] (n=2..31)

Address offset: 0x200 + (n × 0x4)

Controls the selection of the resources in the trace unit.

Might ignore writes when the trace unit is enabled or not idle.

If software selects a non-implemented resource then CONSTRAINED UNPREDICTABLE behavior of the resource selector occurs, so the resource selector might fire unexpectedly or might not fire. Reads of the TRCRSCTLRn might return UNKNOWN.

Bit number	31	30	29	28	27	26	25	24	23	22	21	20	19	18	17	16	15	14	13	12	11	10	9	8	7	6	5	4	3	2	1	0
ID	A																															
Reset 0x00000000	0 0																															
ID	R/W	Field	Value ID	Value	Description																											
A	RW	EN			Trace unit enable bit																											
			Disabled	0	The trace unit is disabled. All trace resources are inactive and no trace is generated.																											
			Enabled	1	The trace unit is enabled.																											

9.7.4.1.29 TRCSSCCRO

Address offset: 0x280

Controls the single-shot comparator.

Bit number	31	30	29	28	27	26	25	24	23	22	21	20	19	18	17	16	15	14	13	12	11	10	9	8	7	6	5	4	3	2	1	0
ID	A																															
Reset 0x00000000	0 0																															
ID	R/W	Field	Value ID	Value	Description																											
A	RW	RST			Enables the single-shot comparator resource to be reset when it occurs, to enable another comparator match to be detected																											
			Disabled	0	Multiple matches can not be detected.																											
			Enabled	1	Multiple matches can occur.																											

9.7.4.1.30 TRCSSCSR0

Address offset: 0x2A0

Indicates the status of the single-shot comparators. TRCSSCSR0 is sensitive to instruction addresses.

Bit number		31 30 29 28 27 26 25 24 23 22 21 20 19 18 17 16 15 14 13 12 11 10 9 8 7 6 5 4 3 2 1 0																														
ID		E																												D C B A		
Reset 0x00000000		0 0																														
ID	R/W	Field	Value ID	Value	Description																											
A	RW	INST			Instruction address comparator support																											
			False	0	Single-shot instruction address comparisons not supported.																											
			True	1	Single-shot instruction address comparisons supported.																											
B	RW	DA			Data address comparator support																											
			False	0	Data address comparisons not supported.																											
			True	1	Data address comparisons supported.																											
C	RW	DV			Data value comparator support																											
			False	0	Data value comparisons not supported.																											
			True	1	Data value comparisons supported.																											
D	RW	PC			Process counter value comparator support																											
			False	0	Process counter value comparisons not supported.																											
			True	1	Process counter value comparisons supported.																											
E	RW	STATUS			Single-shot status. This indicates whether any of the selected comparators have matched.																											
			NoMatch	0	Match has not occurred.																											
			Match	1	Match has occurred at least once.																											

9.7.4.1.31 TRCSSPCICRO

Address offset: 0x2C0

Selects the processor comparator inputs for Single-shot control.

Bit number		31 30 29 28 27 26 25 24 23 22 21 20 19 18 17 16 15 14 13 12 11 10 9 8 7 6 5 4 3 2 1 0																														
ID																														D C B A		
Reset 0x00000000		0 0																														
ID	R/W	Field	Value ID	Value	Description																											
A-D	RW	PC[i] (i=0..3)			Selects processor comparator i inputs for Single-shot control																											
			Disabled	0	Processor comparator i is not selected for Single-shot control.																											
			Enabled	1	Processor comparator i is selected for Single-shot control.																											

9.7.4.1.32 TRCPDCR

Address offset: 0x310

Controls the single-shot comparator.

Bit number		31 30 29 28 27 26 25 24 23 22 21 20 19 18 17 16 15 14 13 12 11 10 9 8 7 6 5 4 3 2 1 0																														
ID																														A		
Reset 0x00000000		0 0																														
ID	R/W	Field	Value ID	Value	Description																											
A	RW	PU			Power up request, to request that power to ETM and access to the trace registers is maintained.																											
			Disabled	0	Power not requested.																											
			Enabled	1	Power requested.																											

9.7.4.1.33 TRCPDSR

Address offset: 0x314

Indicates the power down status of the ETM.

Bit number	31 30 29 28 27 26 25 24 23 22 21 20 19 18 17 16 15 14 13 12 11 10 9 8 7 6 5 4 3 2 1 0																															
ID																															B	A
Reset 0x00000000	0 0																															
ID	R/W	Field	Value ID	Value	Description																											
A	RW	POWER			Indicates ETM is powered up																											
			NotPoweredUp	0	ETM is not powered up. All registers are not accessible.																											
			PoweredUp	1	ETM is powered up. All registers are accessible.																											
B	RW	STICKYPD			Sticky power down state.																											
					This bit is set to 1 when power to the ETM registers is removed, to indicate that programming state has been lost. It is cleared after a read of the TRCPDSR																											
			NotPoweredDown	0	Trace register power has not been removed since the TRCPDSR was last read.																											
			PoweredDown	1	Trace register power has been removed since the TRCPDSR was last read.																											

9.7.4.1.34 TRCITATBIDR

Address offset: 0xEE4

Sets the state of output pins.

Bit number	31 30 29 28 27 26 25 24 23 22 21 20 19 18 17 16 15 14 13 12 11 10 9 8 7 6 5 4 3 2 1 0																																				
ID																															G	F	E	D	C	B	A
Reset 0x00000000	0 0																																				
ID	R/W	Field	Value ID	Value	Description																																
A-G	RW	ID[i] (i=0..6)			Drives the ATIDMI[i] output pin.																																

9.7.4.1.35 TRCITIATBINR

Address offset: 0xEF4

Reads the state of the input pins.

Bit number	31 30 29 28 27 26 25 24 23 22 21 20 19 18 17 16 15 14 13 12 11 10 9 8 7 6 5 4 3 2 1 0																															
ID																															B	A
Reset 0x00000000	0 0																															
ID	R/W	Field	Value ID	Value	Description																											
A	RW	ATVALID			Returns the value of the ATVALIDMI input pin.																											
B	RW	AFREADY			Returns the value of the AFREADYMI input pin.																											

9.7.4.1.36 TRCITIATBOUTR

Address offset: 0xEFC

Sets the state of the output pins.

Bit number	31 30 29 28 27 26 25 24 23 22 21 20 19 18 17 16 15 14 13 12 11 10 9 8 7 6 5 4 3 2 1 0																															
ID																															B	A
Reset 0x00000000	0 0																															
ID	R/W	Field	Value ID	Value	Description																											
A	RW	ATVALID			Drives the ATVALIDMI output pin.																											
B	RW	AFREADY			Drives the AFREADYMI output pin.																											

9.7.4.1.37 TRCITCTRL

Address offset: 0xF00

Enables topology detection or integration testing, by putting ETM-M33 into integration mode.

Bit number	31 30 29 28 27 26 25 24 23 22 21 20 19 18 17 16 15 14 13 12 11 10 9 8 7 6 5 4 3 2 1 0																															
ID																																A
Reset 0x00000000	0 0																															
ID	R/W	Field	Value ID	Value	Description																											
A	RW	IME			Integration mode enable																											
			Disabled	0	ETM is not in integration mode.																											
			Enabled	1	ETM is in integration mode.																											

9.7.4.1.38 TRCCLAIMSET

Address offset: 0xFA0

Sets bits in the claim tag and determines the number of claim tag bits implemented.

Bit number	31 30 29 28 27 26 25 24 23 22 21 20 19 18 17 16 15 14 13 12 11 10 9 8 7 6 5 4 3 2 1 0																															
ID																																D C B A
Reset 0x00000000	0 0																															
ID	R/W	Field	Value ID	Value	Description																											
A-D	RW	SET[i] (i=0..3)			Claim tag set register																											
			NotSet	0	Claim tag i is not set.																											
			Set	1	Claim tag i is set.																											
			Claim	1	Set claim tag i.																											

9.7.4.1.39 TRCCLAIMCLR

Address offset: 0xFA4

Clears bits in the claim tag and determines the current value of the claim tag.

Bit number	31 30 29 28 27 26 25 24 23 22 21 20 19 18 17 16 15 14 13 12 11 10 9 8 7 6 5 4 3 2 1 0																															
ID																																D C B A
Reset 0x00000000	0 0																															
ID	R/W	Field	Value ID	Value	Description																											
A-D	RW	CLR[i] (i=0..3)			Claim tag clear register																											
			NotSet	0	Claim tag i is not set.																											
			Set	1	Claim tag i is set.																											
			Clear	1	Clear claim tag i.																											

9.7.4.1.40 TRCAUTHSTATUS

Address offset: 0xFB8

Indicates the current level of tracing permitted by the system

Bit number	31 30 29 28 27 26 25 24 23 22 21 20 19 18 17 16 15 14 13 12 11 10 9 8 7 6 5 4 3 2 1 0																															
ID																																D D C C B B A A
Reset 0x00000000	0 0																															
ID	R/W	Field	Value ID	Value	Description																											
A	RW	NSID			Non-secure Invasive Debug																											

Bit number	31 30 29 28 27 26 25 24 23 22 21 20 19 18 17 16 15 14 13 12 11 10 9 8 7 6 5 4 3 2 1 0																																																								
ID																															D	D	C	C	B	B	A	A																			
Reset 0x00000000	0 0																																																								
ID	R/W	Field	Value ID	Value	Description																																																				
			NotImplemented	0	The feature is not implemented.																																																				
			Implemented	1	The feature is implemented.																																																				
B	RW	NSNID			Non-secure Non-Invasive Debug																																																				
			NotImplemented	0	The feature is not implemented.																																																				
			Implemented	1	The feature is implemented.																																																				
C	RW	SID			Secure Invasive Debug																																																				
			NotImplemented	0	The feature is not implemented.																																																				
			Implemented	1	The feature is implemented.																																																				
D	RW	SNID			Secure Non-Invasive Debug																																																				
			NotImplemented	0	The feature is not implemented.																																																				
			Implemented	1	The feature is implemented.																																																				

9.7.4.1.41 TRCDEVARCH

Address offset: 0xFBC

The TRCDEVARCH identifies ETM-M33 as an ETMv4.2 component

Bit number	31 30 29 28 27 26 25 24 23 22 21 20 19 18 17 16 15 14 13 12 11 10 9 8 7 6 5 4 3 2 1 0																																																								
ID																															D	D	D	D	D	D	D	D	D	C	B	B	B	B	A	A	A	A	A	A	A	A	A	A	A	A	A
Reset 0x00000000	0 0																																																								
ID	R/W	Field	Value ID	Value	Description																																																				
A	R	ARCHID			Architecture ID																																																				
			ETMv42	0x4A13	Component is an ETMv4 component																																																				
B	R	REVISION			Architecture revision																																																				
			v2	2	Component is part of architecture 4.2																																																				
C	R	PRESENT			This register is implemented																																																				
			Absent	0	The register is not implemented.																																																				
			Present	1	The register is implemented.																																																				
D	R	ARCHITECT			Defines the architect of the component																																																				
			Arm	0x23B	This peripheral was architected by Arm.																																																				

9.7.4.1.42 TRCDEVTYPE

Address offset: 0xFCC

Controls the single-shot comparator.

Bit number	31 30 29 28 27 26 25 24 23 22 21 20 19 18 17 16 15 14 13 12 11 10 9 8 7 6 5 4 3 2 1 0																																																							
ID																															B	B	B	B	A	A	A																			
Reset 0x00000000	0 0																																																							
ID	R/W	Field	Value ID	Value	Description																																																			
A	R	MAJOR			The main type of the component																																																			
			TraceSource	3	Peripheral is a trace source.																																																			
B	R	SUB			The sub-type of the component																																																			
			ProcessorTrace	1	Peripheral is a processor trace source.																																																			

9.7.4.1.43 TRCPIDR[n] (n=0..7)

Address offset: 0xFD0 + (n × 0x4)

Coresight peripheral identification registers.

Bit number	31	30	29	28	27	26	25	24	23	22	21	20	19	18	17	16	15	14	13	12	11	10	9	8	7	6	5	4	3	2	1	0
ID																																
Reset 0x00000000	0 0																															
ID	R/W	Field	Value ID	Value	Description																											

9.7.4.1.44 TRCCIDR[n] (n=0..3)

Address offset: 0xFF0 + (n × 0x4)

Coresight component identification registers.

Bit number	31	30	29	28	27	26	25	24	23	22	21	20	19	18	17	16	15	14	13	12	11	10	9	8	7	6	5	4	3	2	1	0
ID																																
Reset 0x00000000	0 0																															
ID	R/W	Field	Value ID	Value	Description																											

9.7.5 TPIU — Trace port interface unit

The ARM® CoreSight™ TPIU connects an ATB to an external trace port.

This document only provides a register-level description of this ARM component. See the [ARM® CoreSight™ SoC-400 Technical Reference Manual](#) for more details

9.7.5.1 Registers

Instances

Instance	Base address	TrustZone			Split access	Description
		Map	Att	DMA		
TPIU	0xE0054000	HF	NS	NA	No	TPIU

Register overview

Register	Offset	TZ	Description
SUPPORTEDPORTSIZES	0x000		Each bit location is a single port size that is supported on the device.
CURRENTPORTSIZE	0x004		Each bit location is a single port size. One bit can be set, and indicates the current port size.
SUPPORTEDTRIGGERMODES	0x100		The Supported_trigger_modes register indicates the implemented trigger counter multipliers and other supported features of the trigger system.
TRIGGERCOUNTERVALUE	0x104		The Trigger_counter_value register enables delaying the indication of triggers to any external connected trace capture or storage devices.
TRIGGERMULTIPLIER	0x108		The Trigger_multiplier register contains the selectors for the trigger counter multiplier.
SUPPORTEDTESTPATTERNMODES	0x200		The Supported_test_pattern_modes register provides a set of known bit sequences or patterns that can be output over the trace port and can be detected by the TPA or other associated trace capture device.
CURRENTTESTPATTERNMODES	0x204		Current_test_pattern_mode indicates the current test pattern or mode selected.
TPRCR	0x208		The TPRCR register is an 8-bit counter start value that is decremented. A write sets the initial counter value and a read returns the programmed value.
FFSR	0x300		The FFSR register indicates the current status of the formatter and flush features available in the TPIU.
FFCR	0x304		The FFCR register controls the generation of stop, trigger, and flush events.
FSCR	0x308		The FSCR register enables the frequency of synchronization information to be optimized to suit the Trace Port Analyzer (TPA) capture buffer size.

Register	Offset	TZ	Description
EXTCTLINPORT	0x400		Two ports can be used as a control and feedback mechanism for any serializers, pin sharing multiplexers, or other solutions that might be added to the trace output pins either for pin control or a high-speed trace port solution.
EXTCTLOUTPORT	0x404		Two ports can be used as a control and feedback mechanism for any serializers, pin sharing multiplexers, or other solutions that might be added to the trace output pins either for pin control or a high speed trace port solution. These ports are raw register banks that sample or export the corresponding external pins.
ITTRFLINACK	0xEE4		The ITTRFLINACK register enables control of the triginack and flushinack outputs from the TPIU.
ITTRFLIN	0xEE8		The ITTRFLIN register contains the values of the flushin and trigin inputs to the TPIU.
ITATBDATA0	0xEEC		The ITATBDATA0 register contains the value of the atdatas inputs to the TPIU. The values are valid only when atvalids is HIGH.
ITATBCTR2	0xEF0		Enables control of the atreadys and avalids outputs of the TPIU.
ITATBCTR1	0xEF4		The ITATBCTR1 register contains the value of the atids input to the TPIU. This is only valid when atvalids is HIGH.
ITATBCTR0	0xEF8		The ITATBCTR0 register captures the values of the atvalids, atreadys, and atbytes inputs to the TPIU. To ensure the integration registers work correctly in a system, the value of atbytes is only valid when atvalids, bit[0], is HIGH.
ITCTRL	0xF00		Used to enable topology detection. This register enables the component to switch from a functional mode, the default behavior, to integration mode where the inputs and outputs of the component can be directly controlled for integration testing and topology solving.
CLAIMSET	0xFA0		Software can use the claim tag to coordinate application and debugger access to trace unit functionality. The claim tags have no effect on the operation of the component. The CLAIMSET register sets bits in the claim tag, and determines the number of claim bits implemented.
CLAIMCLR	0xFA4		Software can use the claim tag to coordinate application and debugger access to trace unit functionality. The claim tags have no effect on the operation of the component. The CLAIMCLR register sets the bits in the claim tag to 0 and determines the current value of the claim tag.
LAR	0xFB0		This is used to enable write access to device registers.
LSR	0xFB4		This indicates the status of the lock control mechanism. This lock prevents accidental writes by code under debug. Accesses to the extended stimulus port registers are not affected by the lock mechanism. This register must always be present although there might not be any lock access control mechanism. The lock mechanism, where present and locked, must block write accesses to any control register, except the Lock Access Register. For most components this covers all registers except for the Lock Access Register.
AUTHSTATUS	0xFB8		Indicates the current level of tracing permitted by the system
DEVID	0xFC8		Indicates the capabilities of the component.
DEVTYPE	0xFCC		The DEVTYPE register provides a debugger with information about the component when the Part Number field is not recognized. The debugger can then report this information.
PIDR4	0xFD0		Coresight peripheral identification registers.
PIDR[0]	0xFE0		Coresight peripheral identification registers.
PIDR[1]	0xFE4		Coresight peripheral identification registers.
PIDR[2]	0xFE8		Coresight peripheral identification registers.
PIDR[3]	0xFEC		Coresight peripheral identification registers.
CIDR[0]	0xFF0		Coresight component identification registers.
CIDR[1]	0xFF4		Coresight component identification registers.
CIDR[2]	0xFF8		Coresight component identification registers.
CIDR[3]	0xFFC		Coresight component identification registers.

9.7.5.1.1 SUPPORTEDPORTSIZES

Address offset: 0x000

Each bit location is a single port size that is supported on the device.

Bit number	31	30	29	28	27	26	25	24	23	22	21	20	19	18	17	16	15	14	13	12	11	10	9	8	7	6	5	4	3	2	1	0
ID	f	e	d	c	b	a	Z	Y	X	W	V	U	T	S	R	Q	P	O	N	M	L	K	J	I	H	G	F	E	D	C	B	A
Reset 0x00000000	0	0	0	0	0	0	0	0	0	0	0	0	0	0	0	0	0	0	0	0	0	0	0	0	0	0	0	0	0	0	0	0
ID	R/W	Field	Value ID	Value	Description																											
A-f	RW	PORT_SIZE_[i+1] (i=0..31)			Indicates whether the TPIU supports port size of i+1-bit.																											
			NotSupported	0	Port size i+1 is not supported.																											
			Supported	1	Port size i+1 is supported.																											

9.7.5.1.2 CURRENTPORTSIZE

Address offset: 0x004

Each bit location is a single port size. One bit can be set, and indicates the current port size.

Bit number	31	30	29	28	27	26	25	24	23	22	21	20	19	18	17	16	15	14	13	12	11	10	9	8	7	6	5	4	3	2	1	0
ID	f	e	d	c	b	a	Z	Y	X	W	V	U	T	S	R	Q	P	O	N	M	L	K	J	I	H	G	F	E	D	C	B	A
Reset 0x00000000	0	0	0	0	0	0	0	0	0	0	0	0	0	0	0	0	0	0	0	0	0	0	0	0	0	0	0	0	0	0	0	0
ID	R/W	Field	Value ID	Value	Description																											
A-f	RW	PORT_SIZE_[i+1] (i=0..31)			Indicates which port size is currently selected.																											
			NotSelected	0	Port size i+1 is not selected.																											
			Selected	1	Port size i+1 is selected.																											

9.7.5.1.3 SUPPORTEDTRIGGERMODES

Address offset: 0x100

The Supported_trigger_modes register indicates the implemented trigger counter multipliers and other supported features of the trigger system.

Bit number	31	30	29	28	27	26	25	24	23	22	21	20	19	18	17	16	15	14	13	12	11	10	9	8	7	6	5	4	3	2	1	0	
ID																																	
Reset 0x00000000	0	0	0	0	0	0	0	0	0	0	0	0	0	0	0	0	0	0	0	0	0	0	0	0	0	0	0	0	0	0	0	0	
ID	R/W	Field	Value ID	Value	Description																												
A-E	RW	MULT[i] (i=0..4)			Indicates whether multiplying the trigger counter by 2 ⁽ⁱ⁺¹⁾ is supported.																												
			NotSelected	0	Multiplying the trigger counter by 2 ⁽ⁱ⁺¹⁾ is supported.																												
			Selected	1	Multiplying the trigger counter by 2 ⁽ⁱ⁺¹⁾ is supported.																												
F	RW	TCOUNT8			Indicates whether an 8-bit wide counter register is implemented.																												
			NotImplemented	0	An 8-bit wide counter register is implemented.																												
			Implemented	1	An 8-bit wide counter register is implemented.																												
G	RW	TRIGGERED			A trigger has occurred and the counter has reached 0.																												
			NotOccured	0	Trigger has not occurred.																												
			Occured	1	Trigger has occurred.																												
H	RW	TRGRUN			A trigger has occurred but the counter is not at 0.																												
			NotOccured	0	Either a trigger has not occurred or the counter is at 0.																												
			Occured	1	A trigger has occurred but the counter is not at 0.																												

9.7.5.1.4 TRIGGERCOUNTERVALUE

Address offset: 0x104

The Trigger_counter_value register enables delaying the indication of triggers to any external connected trace capture or storage devices.

Bit number	31	30	29	28	27	26	25	24	23	22	21	20	19	18	17	16	15	14	13	12	11	10	9	8	7	6	5	4	3	2	1	0																							
ID																											A	A	A	A	A	A	A	A	A	A	A	A	A	A	A	A	A	A	A	A	A	A	A	A	A	A	A	A	A
Reset 0x00000000	0 0																																																						
ID	R/W	Field	Value ID	Value	Description																																																		
A	RW	TrigCount		[0:255]	8-bit counter value for the number of words to be output from the formatter before a trigger is inserted.																																																		

9.7.5.1.5 TRIGGERMULTIPLIER

Address offset: 0x108

The Trigger_multiplier register contains the selectors for the trigger counter multiplier.

Bit number	31	30	29	28	27	26	25	24	23	22	21	20	19	18	17	16	15	14	13	12	11	10	9	8	7	6	5	4	3	2	1	0																						
ID																											E	D	C	B	A	A	A	A	A	A	A	A	A	A	A	A	A	A	A	A	A	A	A	A	A	A	A	A
Reset 0x00000000	0 0																																																					
ID	R/W	Field	Value ID	Value	Description																																																	
A-E	RW	MULT[i] (i=0..4)			Multiply the Trigger Counter by 2^n.																																																	
			Disabled	0	Multiplier disabled.																																																	
			Enabled	1	Multiplier enabled.																																																	

9.7.5.1.6 SUPPORTEDTESTPATTERNMODES

Address offset: 0x200

The Supported_test_pattern_modes register provides a set of known bit sequences or patterns that can be output over the trace port and can be detected by the TPA or other associated trace capture device.

Bit number	31	30	29	28	27	26	25	24	23	22	21	20	19	18	17	16	15	14	13	12	11	10	9	8	7	6	5	4	3	2	1	0																							
ID																											F	E	A	A	A	A	A	A	A	A	A	A	A	A	A	A	A	A	A	A	A	A	A	A	A	A	A	A	A
Reset 0x00000000	0 0																																																						
ID	R/W	Field	Value ID	Value	Description																																																		
A	RW	PATW1			Indicates whether the walking 1s pattern is supported as output over the trace port.																																																		
			NotSupported	0	Test pattern is not supported.																																																		
			Supported	1	Test pattern is supported.																																																		
B	RW	PATW0			Indicates whether the walking 0s pattern is supported as output over the trace port.																																																		
			NotSupported	0	Test pattern is not supported.																																																		
			Supported	1	Test pattern is supported.																																																		
C	RW	PATA5			Indicates whether the AA/55 pattern is supported as output over the trace port.																																																		
			NotSupported	0	Test pattern is not supported.																																																		
			Supported	1	Test pattern is supported.																																																		
D	RW	PATF0			Indicates whether the FF/00 pattern is supported as output over the trace port.																																																		
			NotSupported	0	Test pattern is not supported.																																																		
			Supported	1	Test pattern is supported.																																																		
E	RW	PTIMEEN			Indicates whether timed mode is supported.																																																		
			NotSupported	0	Mode is not supported.																																																		
			Supported	1	Mode is supported.																																																		
F	RW	PCONTEN			Indicates whether continuous mode is supported.																																																		
			NotSupported	0	Mode is not supported.																																																		
			Supported	1	Mode is supported.																																																		

9.7.5.1.7 CURRENTTESTPATTERNMODES

Address offset: 0x204

Current_test_pattern_mode indicates the current test pattern or mode selected.

Bit number	31 30 29 28 27 26 25 24 23 22 21 20 19 18 17 16 15 14 13 12 11 10 9 8 7 6 5 4 3 2 1 0																																	
ID																									F	E					D	C	B	A
Reset 0x00000000	0 0																																	
ID	R/W	Field	Value ID	Value	Description																													
A	RW	PATW1			Indicates whether the walking 1s pattern is supported as output over the trace port.																													
			Disabled	0	Test pattern is disabled.																													
			Enabled	1	Test pattern is enabled.																													
B	RW	PATW0			Indicates whether the walking 0s pattern is supported as output over the trace port.																													
			Disabled	0	Test pattern is disabled.																													
			Enabled	1	Test pattern is enabled.																													
C	RW	PATAS			Indicates whether the AA/55 pattern is supported as output over the trace port.																													
			Disabled	0	Test pattern is disabled.																													
			Enabled	1	Test pattern is enabled.																													
D	RW	PATF0			Indicates whether the FF/00 pattern is supported as output over the trace port.																													
			Disabled	0	Test pattern is disabled.																													
			Enabled	1	Test pattern is enabled.																													
E	RW	PTIMEEN			Indicates whether timed mode is supported.																													
			Disabled	0	Mode is disabled.																													
			Enabled	1	Mode is enabled.																													
F	RW	PCONTEN			Indicates whether continuous mode is supported.																													
			Disabled	0	Mode is disabled.																													
			Enabled	1	Mode is enabled.																													

9.7.5.1.8 TPRCR

Address offset: 0x208

The TPRCR register is an 8-bit counter start value that is decremented. A write sets the initial counter value and a read returns the programmed value.

Bit number	31 30 29 28 27 26 25 24 23 22 21 20 19 18 17 16 15 14 13 12 11 10 9 8 7 6 5 4 3 2 1 0																														
ID																									A	A	A	A	A	A	A
Reset 0x00000000	0 0																														
ID	R/W	Field	Value ID	Value	Description																										
A	RW	PATTCOUNT		[0:255]	8-bit counter value to indicate the number of traceclk cycles for which a pattern runs before it switches to the next pattern.																										

9.7.5.1.9 FFSR

Address offset: 0x300

The FFSR register indicates the current status of the formatter and flush features available in the TPIU.

Bit number	31 30 29 28 27 26 25 24 23 22 21 20 19 18 17 16 15 14 13 12 11 10 9 8 7 6 5 4 3 2 1 0																																
ID																															C	B	A
Reset 0x00000000	0 0																																
ID	R/W	Field	Value ID	Value	Description																												
A	RW	FLINPROG			Flush in progress.																												
			NotInProgress	0	A flush is not in progress.																												
			InProgress	1	A flush is in progress.																												
B	RW	FTSTOPPED			The formatter has received a stop request signal and all trace data and postamble is sent. Any additional trace data on the ATB interface is ignored and atreadys goes HIGH.																												
			Running	0	Formatter has not stopped.																												
			Stopped	1	Formatter has stopped.																												
C	RW	TCPRESENT			Indicates whether the TRACECTL pin is available for use.																												
			NotPresent	0	TRACECTL pin is not present.																												
			Present	1	TRACECTL pin is present.																												

9.7.5.1.10 FFCR

Address offset: 0x304

The FFCR register controls the generation of stop, trigger, and flush events.

Bit number	31 30 29 28 27 26 25 24 23 22 21 20 19 18 17 16 15 14 13 12 11 10 9 8 7 6 5 4 3 2 1 0																																											
ID																													K	J	I	H	G	F	E	D	C						B	A
Reset 0x00000000	0 0																																											
ID	R/W	Field	Value ID	Value	Description																																							
A	RW	ENFTC			Do not embed triggers into the formatted stream. Trace disable cycles and triggers are indicated by tracectl, where present.																																							
			Disabled	0	The formatting feature is disabled.																																							
			Enabled	1	The formatting feature is enabled.																																							
B	RW	ENFCONT			Is embedded in trigger packets and indicates that no cycle is using sync packets.																																							
			Disabled	0	The formatting feature is disabled.																																							
			Enabled	1	The formatting feature is enabled.																																							
C	RW	FONFLIN			Enables the use of the flushin connection.																																							
			Disabled	0	The formatting feature is disabled.																																							
			Enabled	1	The formatting feature is enabled.																																							
D	RW	FONTRIG			Initiates a manual flush of data in the system when a trigger event occurs.																																							
			Disabled	0	The formatting feature is disabled.																																							
			Enabled	1	The formatting feature is enabled.																																							
E	RW	FONMANR			Generates a flush. This bit is set to 0 when this flush is serviced.																																							
			Disabled	0	The formatting feature is disabled.																																							
			Enabled	1	The formatting feature is enabled.																																							
F	RW	FONMANW			Generates a flush. This bit is set to 1 when this flush is serviced.																																							
			Disabled	0	The formatting feature is disabled.																																							
			Enabled	1	The formatting feature is enabled.																																							
G	RW	TRIGIN			Indicates a trigger when trigin is asserted.																																							
			Disabled	0	The formatting feature is disabled.																																							
			Enabled	1	The formatting feature is enabled.																																							
H	RW	TRIG EVT			Indicates a trigger on a trigger event.																																							
			Disabled	0	The formatting feature is disabled.																																							
			Enabled	1	The formatting feature is enabled.																																							
I	RW	TRIGFL			Indicates a trigger when flush completion on aheadys is returned.																																							
			Disabled	0	The formatting feature is disabled.																																							

Bit number	31 30 29 28 27 26 25 24 23 22 21 20 19 18 17 16 15 14 13 12 11 10 9 8 7 6 5 4 3 2 1 0																																											
ID																												K	J				I	H	G	F	E	D	C				B	A
Reset 0x00000000	0 0																																											
ID	R/W	Field	Value ID	Value	Description																																							
			Enabled	1	The formatting feature is enabled.																																							
J	RW	STOPFL			Forces the FIFO to drain off any part-completed packets.																																							
			Disabled	0	The formatting feature is disabled.																																							
			Enabled	1	The formatting feature is enabled.																																							
K	RW	STOPTRIG			Stops the formatter after a trigger event is observed. Reset to disabled or 0.																																							
			Disabled	0	The formatting feature is disabled.																																							
			Enabled	1	The formatting feature is enabled.																																							

9.7.5.1.11 FSCR

Address offset: 0x308

The FSCR register enables the frequency of synchronization information to be optimized to suit the Trace Port Analyzer (TPA) capture buffer size.

Bit number	31 30 29 28 27 26 25 24 23 22 21 20 19 18 17 16 15 14 13 12 11 10 9 8 7 6 5 4 3 2 1 0																																										
ID																												A	A	A	A	A	A	A	A	A	A	A	A	A	A	A	A
Reset 0x00000000	0 0																																										
ID	R/W	Field	Value ID	Value	Description																																						
A	RW	CYCCOUNT		[0:1024]	12-bit counter reload value. Indicates the number of complete frames between full synchronization packets.																																						

9.7.5.1.12 EXTCTLINPORT

Address offset: 0x400

Two ports can be used as a control and feedback mechanism for any serializers, pin sharing multiplexers, or other solutions that might be added to the trace output pins either for pin control or a high-speed trace port solution.

Bit number	31 30 29 28 27 26 25 24 23 22 21 20 19 18 17 16 15 14 13 12 11 10 9 8 7 6 5 4 3 2 1 0																																		
ID																												H	G	F	E	D	C	B	A
Reset 0x00000000	0 0																																		
ID	R/W	Field	Value ID	Value	Description																														
A-H	RW	EXTCTLIN[i] (i=0..7)			EXTCTL inputs.																														
			Low	0	Input EXTCTLi is low.																														
			High	1	Input EXTCTLi is high.																														

9.7.5.1.13 EXTCTLOUTPORT

Address offset: 0x404

Two ports can be used as a control and feedback mechanism for any serializers, pin sharing multiplexers, or other solutions that might be added to the trace output pins either for pin control or a high speed trace port solution. These ports are raw register banks that sample or export the corresponding external pins.

Bit number	31	30	29	28	27	26	25	24	23	22	21	20	19	18	17	16	15	14	13	12	11	10	9	8	7	6	5	4	3	2	1	0		
ID																											H	G	F	E	D	C	B	A
Reset 0x00000000	0 0																																	
ID	R/W	Field	Value ID	Value	Description																													
A-H	RW	EXTCTLOUT[i] (i=0..7)			EXTCTL outputs.																													
			Low	0	Output EXTCTLi is low.																													
			High	1	Output EXTCTLi is high.																													

9.7.5.1.14 ITTRFLINACK

Address offset: 0xEE4

The ITTRFLINACK register enables control of the triginack and flushinack outputs from the TPIU.

Bit number	31	30	29	28	27	26	25	24	23	22	21	20	19	18	17	16	15	14	13	12	11	10	9	8	7	6	5	4	3	2	1	0
ID																											B	A				
Reset 0x00000000	0 0																															
ID	R/W	Field	Value ID	Value	Description																											
A	RW	TRIGINACK			Sets the value of triginack.																											
			Low	0	Pin is logic 0.																											
			High	1	Pin is logic 1.																											
B	RW	FLUSHINACK			Sets the value of flushinack.																											
			Low	0	Pin is logic 0.																											
			High	1	Pin is logic 1.																											

9.7.5.1.15 ITTRFLIN

Address offset: 0xEE8

The ITTRFLIN register contains the values of the flushin and trigin inputs to the TPIU.

Bit number	31	30	29	28	27	26	25	24	23	22	21	20	19	18	17	16	15	14	13	12	11	10	9	8	7	6	5	4	3	2	1	0
ID																											B	A				
Reset 0x00000000	0 0																															
ID	R/W	Field	Value ID	Value	Description																											
A	RW	TRIGIN			Reads the value of trigin.																											
			Low	0	Pin is logic 0.																											
			High	1	Pin is logic 1.																											
B	RW	FLUSHIN			Reads the value of flushin.																											
			Low	0	Pin is logic 0.																											
			High	1	Pin is logic 1.																											

9.7.5.1.16 ITATBDATA0

Address offset: 0xEEC

The ITATBDATA0 register contains the value of the atdatas inputs to the TPIU. The values are valid only when atvalids is HIGH.

Bit number	31	30	29	28	27	26	25	24	23	22	21	20	19	18	17	16	15	14	13	12	11	10	9	8	7	6	5	4	3	2	1	0																							
ID																											E	D	C	B	A																								
Reset	0x00000000																										0	0	0	0	0	0	0	0	0	0	0	0	0	0	0	0	0	0	0	0	0	0	0	0	0	0	0	0	0
ID	R/W	Field	Value ID	Value	Description																																																		
A-E	RW	ATDATA[i] (i=0..4)			A read access returns the value of a pin on atdatas_x of the enabled port. A write access writes to the corresponding atdatam pin of the enabled port.																																																		
			Low	0	Pin is logic 0.																																																		
			High	1	Pin is logic 1.																																																		

9.7.5.1.17 ITATBCTR2

Address offset: 0xEF0

Enables control of the atreadys and avalids outputs of the TPIU.

Bit number	31	30	29	28	27	26	25	24	23	22	21	20	19	18	17	16	15	14	13	12	11	10	9	8	7	6	5	4	3	2	1	0																							
ID																											B	A																											
Reset	0x00000000																										0	0	0	0	0	0	0	0	0	0	0	0	0	0	0	0	0	0	0	0	0	0	0	0	0	0	0	0	0
ID	R/W	Field	Value ID	Value	Description																																																		
A	RW	ATREADY			Sets the value of avalid.																																																		
			Low	0	Pin is logic 0.																																																		
			High	1	Pin is logic 1.																																																		
B	RW	AFVALID			Sets the value of atready.																																																		
			Low	0	Pin is logic 0.																																																		
			High	1	Pin is logic 1.																																																		

9.7.5.1.18 ITATBCTR1

Address offset: 0xEF4

The ITATBCTR1 register contains the value of the atids input to the TPIU. This is only valid when atvalids is HIGH.

Bit number	31	30	29	28	27	26	25	24	23	22	21	20	19	18	17	16	15	14	13	12	11	10	9	8	7	6	5	4	3	2	1	0																						
ID																											A	A	A	A	A	A																						
Reset	0x00000000																										0	0	0	0	0	0	0	0	0	0	0	0	0	0	0	0	0	0	0	0	0	0	0	0	0	0	0	0
ID	R/W	Field	Value ID	Value	Description																																																	
A	RW	ATID			Reads the value of atids.																																																	
			Low	0	Pin is logic 0.																																																	
			High	1	Pin is logic 1.																																																	

9.7.5.1.19 ITATBCTR0

Address offset: 0xEF8

The ITATBCTR0 register captures the values of the atvalids, atreadys, and atbytes inputs to the TPIU. To ensure the integration registers work correctly in a system, the value of atbytes is only valid when atvalids, bit[0], is HIGH.

9.7.5.1.22 CLAIMCLR

Address offset: 0xFA4

Software can use the claim tag to coordinate application and debugger access to trace unit functionality. The claim tags have no effect on the operation of the component. The CLAIMCLR register sets the bits in the claim tag to 0 and determines the current value of the claim tag.

Bit number	31	30	29	28	27	26	25	24	23	22	21	20	19	18	17	16	15	14	13	12	11	10	9	8	7	6	5	4	3	2	1	0
ID																	D	C	B	A												
Reset 0x00000000	0 0																															
ID	R/W	Field	Value ID	Value	Description																											
A-D	RW	BIT[i] (i=0..3)			Read or clear claim bit i.																											
			Cleared	0	Claim bit i is not set.																											
			Set	1	Claim bit i is set.																											
			Clear	1	Clear claim bit i.																											

9.7.5.1.23 LAR

Address offset: 0xFB0

This is used to enable write access to device registers.

Bit number	31	30	29	28	27	26	25	24	23	22	21	20	19	18	17	16	15	14	13	12	11	10	9	8	7	6	5	4	3	2	1	0
ID	A	A	A	A	A	A	A	A	A	A	A	A	A	A	A	A	A	A	A	A	A	A	A	A	A	A	A	A	A	A	A	
Reset 0x00000000	0 0																															
ID	R/W	Field	Value ID	Value	Description																											
A	RW	ACCESS			A write of 0xC5ACCE55 enables further write access to this device. Any other write removes write access.																											
			UnLock	0xC5ACCE55	Unlock register interface.																											

9.7.5.1.24 LSR

Address offset: 0xFB4

This indicates the status of the lock control mechanism. This lock prevents accidental writes by code under debug. Accesses to the extended stimulus port registers are not affected by the lock mechanism. This register must always be present although there might not be any lock access control mechanism. The lock mechanism, where present and locked, must block write accesses to any control register, except the Lock Access Register. For most components this covers all registers except for the Lock Access Register.

Bit number	31 30 29 28 27 26 25 24 23 22 21 20 19 18 17 16 15 14 13 12 11 10 9 8 7 6 5 4 3 2 1 0																																
ID																															C	B	A
Reset 0x00000000	0 0																																
ID	R/W	Field	Value ID	Value	Description																												
A	RW	PRESENT	NotImplemented	0	Indicates that a lock control mechanism exists for this device. No lock control mechanism exists, writes to the Lock Access Register are ignored.																												
			Implemented	1	Lock control mechanism is present.																												
B	RW	LOCKED	UnLocked	0	Returns the current status of the Lock. Write access is allowed to this device.																												
			Locked	1	Write access to the component is blocked. All writes to control registers are ignored. Reads are permitted.																												
C	RW	TYPE	Bits32	0	Indicates if the Lock Access Register is implemented as 8-bit or 32-bit. This component implements a 32-bit Lock Access Register.																												
			Bits8	1	This component implements an 8-bit Lock Access Register.																												

9.7.5.1.25 AUTHSTATUS

Address offset: 0xFB8

Indicates the current level of tracing permitted by the system

Bit number	31 30 29 28 27 26 25 24 23 22 21 20 19 18 17 16 15 14 13 12 11 10 9 8 7 6 5 4 3 2 1 0																																					
ID																															D	D	C	C	B	B	A	A
Reset 0x00000000	0 0																																					
ID	R/W	Field	Value ID	Value	Description																																	
A	RW	NSID	NotImplemented	0	Non-secure Invasive Debug The feature is not implemented.																																	
			Implemented	1	The feature is implemented.																																	
B	RW	NSNID	NotImplemented	0	Non-secure Non-Invasive Debug The feature is not implemented.																																	
			Implemented	1	The feature is implemented.																																	
C	RW	SID	NotImplemented	0	Secure Invasive Debug The feature is not implemented.																																	
			Implemented	1	The feature is implemented.																																	
D	RW	SNID	NotImplemented	0	Secure Non-Invasive Debug The feature is not implemented.																																	
			Implemented	1	The feature is implemented.																																	

9.7.5.1.26 DEVID

Address offset: 0xFC8

Indicates the capabilities of the component.

Bit number	31 30 29 28 27 26 25 24 23 22 21 20 19 18 17 16 15 14 13 12 11 10 9 8 7 6 5 4 3 2 1 0																																							
ID																															F	E	D	C	C	B	A	A	A	A
Reset 0x00000000	0 0																																							
ID	R/W	Field	Value ID	Value	Description																																			
A	R	MUXNUM			Indicates the hidden level of input multiplexing. When non-zero, this value indicates the type of multiplexing on the input to the ATB. Currently only 0x00 is supported, that is, no multiplexing is present. This value helps detect the ATB structure.																																			
B	R	CLKRELAT	Synchronous	0	Indicates the relationship between atclk and traceclk. atclk and traceclk are synchronous.																																			

9.7.5.1.30 PIDR[1]

Address offset: 0xFE4

Coresight peripheral identification registers.

Bit number	31	30	29	28	27	26	25	24	23	22	21	20	19	18	17	16	15	14	13	12	11	10	9	8	7	6	5	4	3	2	1	0
ID																																
Reset 0x00000000	0 0																															
ID	R/W	Field	Value ID	Value	Description																											

9.7.5.1.31 PIDR[2]

Address offset: 0xFE8

Coresight peripheral identification registers.

Bit number	31	30	29	28	27	26	25	24	23	22	21	20	19	18	17	16	15	14	13	12	11	10	9	8	7	6	5	4	3	2	1	0
ID																																
Reset 0x00000000	0 0																															
ID	R/W	Field	Value ID	Value	Description																											

9.7.5.1.32 PIDR[3]

Address offset: 0xFEC

Coresight peripheral identification registers.

Bit number	31	30	29	28	27	26	25	24	23	22	21	20	19	18	17	16	15	14	13	12	11	10	9	8	7	6	5	4	3	2	1	0
ID																																
Reset 0x00000000	0 0																															
ID	R/W	Field	Value ID	Value	Description																											

9.7.5.1.33 CIDR[0]

Address offset: 0xFF0

Coresight component identification registers.

Bit number	31	30	29	28	27	26	25	24	23	22	21	20	19	18	17	16	15	14	13	12	11	10	9	8	7	6	5	4	3	2	1	0
ID																																
Reset 0x00000000	0 0																															
ID	R/W	Field	Value ID	Value	Description																											

9.7.5.1.34 CIDR[1]

Address offset: 0xFF4

Coresight component identification registers.

Bit number	31	30	29	28	27	26	25	24	23	22	21	20	19	18	17	16	15	14	13	12	11	10	9	8	7	6	5	4	3	2	1	0
ID																																
Reset 0x00000000	0 0																															
ID	R/W	Field	Value ID	Value	Description																											

9.7.5.1.35 CIDR[2]

Address offset: 0xFF8

Coresight component identification registers.

Bit number	31	30	29	28	27	26	25	24	23	22	21	20	19	18	17	16	15	14	13	12	11	10	9	8	7	6	5	4	3	2	1	0		
ID																																		
Reset 0x00000000	0	0	0	0	0	0	0	0	0	0	0	0	0	0	0	0	0	0	0	0	0	0	0	0	0	0	0	0	0	0	0	0	0	0
ID	R/W	Field	Value ID	Value	Description																													

9.7.5.1.36 CIDR[3]

Address offset: 0xFFC

Coresight component identification registers.

Bit number	31	30	29	28	27	26	25	24	23	22	21	20	19	18	17	16	15	14	13	12	11	10	9	8	7	6	5	4	3	2	1	0	
ID																																	
Reset 0x00000000	0	0	0	0	0	0	0	0	0	0	0	0	0	0	0	0	0	0	0	0	0	0	0	0	0	0	0	0	0	0	0	0	0
ID	R/W	Field	Value ID	Value	Description																												

9.8 CTRL-AP - Control access port

The control access port (CTRL-AP) is a custom access port that enables control of the device when other debug access ports (DAP) have been disabled by the access port protection.

For an overview of the other debug access ports, see [DAP - Debug access port](#) on page 433.

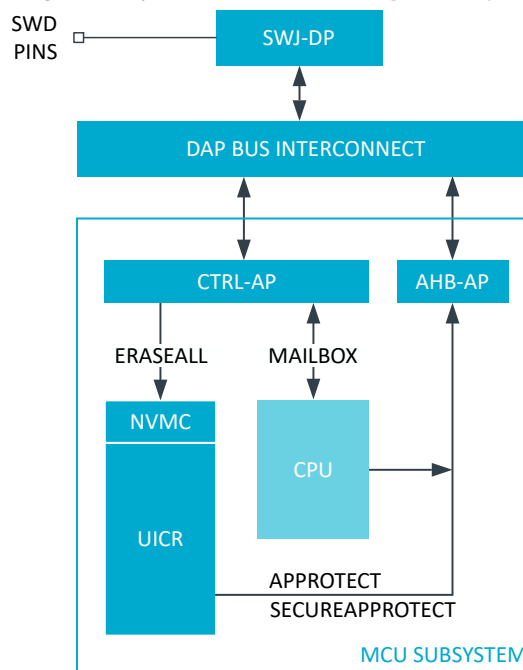

Figure 120: Control access port details

Access port protection (APPROTECT) blocks the debugger access to the AHB-AP, and prevents read and write access to all CPU registers and memory-mapped addresses. To enable port protection access for both secure and non-secure modes, use the registers [SECUREAPPROTECT](#) on page 46 and [APPROTECT](#) on

page 44 respectively. The debugger can use the register [APPROTECT.STATUS](#) on page 502 to read the status of secure and non-secure access port protection.

CTRL-AP has the following features:

- Soft reset
- Erase all
- Mailbox interface
- Debug of protected devices

9.8.1 Reset request

The debugger can request the device to perform a soft reset.

Use the register [RESET](#) on page 501 to request a soft reset. Once the soft reset is performed, the reset reason is accessible on the on-chip firmware through the [RESETRAS](#) register. For more information about the soft reset, see [Reset](#) on page 61.

9.8.2 Erase all

The erase all function lets the debugger trigger an erase of flash, user information configuration registers (UICR), RAM, all peripheral settings, and also removes the access port protection.

To trigger an erase all function, the debugger writes to the register [ERASEALL](#) on page 501. The register [ERASEALLSTATUS](#) on page 501 will read as busy for the duration of the operation. After the next reset, the access port protection is removed.

When erase all is executed, any further writes to [RESET](#) on page 501 are blocked until the device is reset either pin-reset or power-cycle.

If the debugger performs an erase all function on a slave MCU, the erase sequence will always erase the application MCU first, independently of how the application is protected, before erasing the slave MCU.

Erase all protection

It is possible to prevent the debugger from performing an erase all operation by writing to the [UICR.ERASEPROTECT](#) register. Once the register is configured and the device is reset, the CTRL-AP [ERASEALL](#) operation is disabled, and all flash write and erase operations are restricted to the firmware. In addition, it is still possible to write/erase from the debugger as long as the [UICR.APPROTECT](#) register is not set.

Note: Setting the [UICR.ERASEPROTECT](#) register only affects the erase all operation and not the debugger access.

The register [ERASEPROTECT.STATUS](#) on page 502 holds the status for erase protection.

9.8.3 Mailbox interface

CTRL-AP implements a mailbox interface which enables the CPU to communicate with a debugger over the SWD interface.

The mailbox interface consists of a transmit register [MAILBOX.TXDATA](#) on page 503 with its corresponding status register [MAILBOX.TXSTATUS](#) on page 503, and a receive register [MAILBOX.RXDATA](#) on page 503 with its corresponding status register [MAILBOX.RXSTATUS](#) on page 503. Status bits in the TXSTATUS/RXSTATUS registers are set and cleared automatically when the TXDATA/RXDATA registers are written to and read from, independently of the direction.

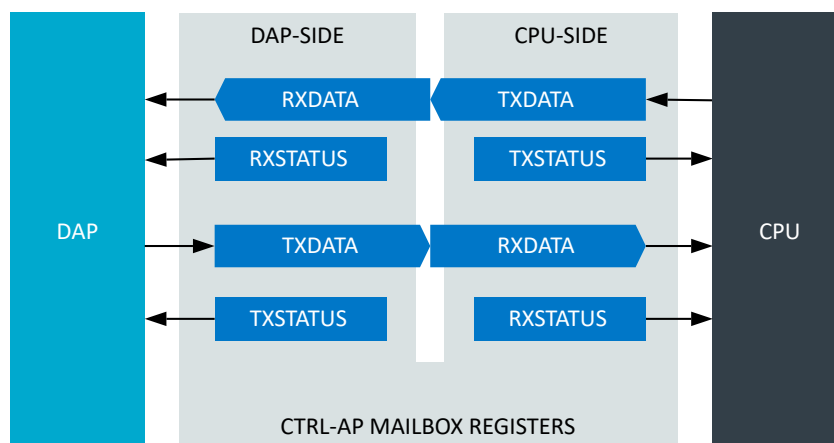

Figure 121: Mailbox register interface

Mailbox transfer sequence

1. Sender writes TXDATA.
2. Hardware sets sender's TXSTATUS to DataPending.
3. Hardware sets receiver's RXSTATUS to DataPending.
4. Receiver reads RXDATA.
5. Hardware sets receiver's RXSTATUS to NoDataPending.
6. Hardware sets sender's TXSTATUS to NoDataPending.

9.8.4 Disabling erase protection

The erase protection mechanism can be disabled to return a device to factory default settings on next reset.

The debugger can read the erase protection status in the register [ERASEPROTECT.STATUS](#) on page 502.

If ERASEPROTECT has been enabled, both the debugger and on-chip firmware must write the same non-zero 32-bit KEY value into their respective ERASEPROTECT.DISABLE registers to disable the erase protection. When both registers have been written with the same non-zero 32-bit KEY value, the device is automatically erased as described in [Erase all](#) on page 499. The access ports will be re-enabled on the next reset once the secure erase sequence has completed.

The write-once register [ERASEPROTECT.LOCK](#) on page 505 should be set to *Locked* as early as possible in the start-up sequence, preferably as soon as the on-chip firmware has determined it does not need to communicate with a debugger over the CTRL-AP mailbox interface. Once written, it will not be possible to remove the erase protection until the next reset.

9.8.5 Debugger registers

CTRL-AP has a set of registers that can only be accessed from the debugger over the SWD interface. These are not accessible from the CPU.

9.8.5.1 Debugger registers

Register overview

Register	Offset	Description
RESET	0x000	System reset request
ERASEALL	0x004	Perform a secure erase of the device, where flash, SRAM and UICR will be erased in sequence. The device will be returned to factory default settings upon next reset.

Register	Offset	Description
ERASEALLSTATUS	0x008	This is the status register for the ERASEALL operation.
APPROTECT.STATUS	0x00C	This is the status register for the UICR access port protection.
ERASEPROTECT.STATUS	0x018	This is the status register for the UICR ERASEPROTECT configuration.
ERASEPROTECT.DISABLE	0x01C	This register disables ERASEPROTECT and performs ERASEALL.
MAILBOX.TXDATA	0x020	Data sent from the debugger to the CPU.
MAILBOX.TXSTATUS	0x024	This register shows a status that indicates if data sent from the debugger to the CPU has been read.
MAILBOX.RXDATA	0x028	Data sent from the CPU to the debugger.
MAILBOX.RXSTATUS	0x02C	This register shows a status that indicates if data sent from the CPU to the debugger has been read.
IDR	0x0FC	CTRL-AP Identification Register, IDR

9.8.5.1.1 RESET

Address offset: 0x000

System reset request

This register is automatically deactivated by writing Erase to ERASEALL, it is then kept inactive until a reset source affecting the debug system is asserted. See [Reset behavior](#) on page 62.

Bit number	31 30 29 28 27 26 25 24 23 22 21 20 19 18 17 16 15 14 13 12 11 10 9 8 7 6 5 4 3 2 1 0																														
ID	A																														
Reset 0x00000000	0 0																														
ID	R/W	Field	Value ID	Value	Description																										
A	RW	RESET			System reset request and status																										
			NoReset	0	Write to release reset																										
					Reading '0' means reset is not active																										
			Reset	1	Write to hold reset																										
					Reading '1' means reset is active																										

9.8.5.1.2 ERASEALL

Address offset: 0x004

Perform a secure erase of the device, where flash, SRAM and UICR will be erased in sequence. The device will be returned to factory default settings upon next reset.

Bit number	31 30 29 28 27 26 25 24 23 22 21 20 19 18 17 16 15 14 13 12 11 10 9 8 7 6 5 4 3 2 1 0																														
ID	A																														
Reset 0x00000000	0 0																														
ID	R/W	Field	Value ID	Value	Description																										
A	W	ERASEALL			Return device to factory default settings																										
			NoOperation	0	No operation																										
			Erase	1	Erase flash, SRAM, and UICR in sequence																										

9.8.5.1.3 ERASEALLSTATUS

Address offset: 0x008

This is the status register for the ERASEALL operation.

Bit number	31	30	29	28	27	26	25	24	23	22	21	20	19	18	17	16	15	14	13	12	11	10	9	8	7	6	5	4	3	2	1	0
ID																																A
Reset 0x00000000	0 0																															
ID	R/W	Field	Value ID	Value	Description																											
A	R	ERASEALLSTATUS			Status bit for the ERASEALL operation																											
			Ready	0	ERASEALL is ready																											
			Busy	1	ERASEALL is busy (on-going)																											

9.8.5.1.4 APPROTECT.STATUS

Address offset: 0x00C

This is the status register for the UICR access port protection.

Bit number	31	30	29	28	27	26	25	24	23	22	21	20	19	18	17	16	15	14	13	12	11	10	9	8	7	6	5	4	3	2	1	0
ID																																B A
Reset 0x00000000	0 0																															
ID	R/W	Field	Value ID	Value	Description																											
A	R	APPROTECT			Status bit for access port protection																											
			Enabled	0	APPROTECT is enabled																											
			Disabled	1	APPROTECT is disabled																											
B	R	SECUREAPPROTECT			Status bit for secure access port protection																											
			Enabled	0	SECUREAPPROTECT is enabled																											
			Disabled	1	SECUREAPPROTECT is disabled																											

Note: The reset value is auto read from the APPROTECT register in UICR.

Note: The reset value is auto read from the SECUREAPPROTECT register in UICR.

9.8.5.1.5 ERASEPROTECT.STATUS

Address offset: 0x018

This is the status register for the UICR ERASEPROTECT configuration.

Bit number	31	30	29	28	27	26	25	24	23	22	21	20	19	18	17	16	15	14	13	12	11	10	9	8	7	6	5	4	3	2	1	0
ID																																A
Reset 0x00000000	0 0																															
ID	R/W	Field	Value ID	Value	Description																											
A	R	PALL			Status bit for erase protection																											
			Enabled	0	ERASEPROTECT is enabled																											
			Disabled	1	ERASEPROTECT is not enabled and ERASEALL can be performed																											

Note: The reset value is auto read from the ERASEPROTECT register in UICR.

9.8.5.1.6 ERASEPROTECT.DISABLE

Address offset: 0x01C

This register disables ERASEPROTECT and performs ERASEALL.

Bit number	31	30	29	28	27	26	25	24	23	22	21	20	19	18	17	16	15	14	13	12	11	10	9	8	7	6	5	4	3	2	1	0
ID	A	A	A	A	A	A	A	A	A	A	A	A	A	A	A	A	A	A	A	A	A	A	A	A	A	A	A	A	A	A	A	A
Reset	0	0	0	0	0	0	0	0	0	0	0	0	0	0	0	0	0	0	0	0	0	0	0	0	0	0	0	0	0	0	0	
ID	R/W	Field	Value ID	Value	Description																											
A	RW1	KEY			The ERASEALL sequence will be initiated if value of the KEY fields are non-zero and the KEY fields match on both the CPU and debugger sides.																											

9.8.5.1.7 MAILBOX.TXDATA

Address offset: 0x020

Data sent from the debugger to the CPU.

Writing to this register will automatically set a DataPending value in the TXSTATUS register.

Bit number	31	30	29	28	27	26	25	24	23	22	21	20	19	18	17	16	15	14	13	12	11	10	9	8	7	6	5	4	3	2	1	0
ID	A	A	A	A	A	A	A	A	A	A	A	A	A	A	A	A	A	A	A	A	A	A	A	A	A	A	A	A	A	A	A	
Reset	0	0	0	0	0	0	0	0	0	0	0	0	0	0	0	0	0	0	0	0	0	0	0	0	0	0	0	0	0	0	0	
ID	R/W	Field	Value ID	Value	Description																											
A	RW	Data			Data sent from debugger																											

9.8.5.1.8 MAILBOX.TXSTATUS

Address offset: 0x024

This register shows a status that indicates if data sent from the debugger to the CPU has been read.

Bit number	31	30	29	28	27	26	25	24	23	22	21	20	19	18	17	16	15	14	13	12	11	10	9	8	7	6	5	4	3	2	1	0
ID																																A
Reset	0	0	0	0	0	0	0	0	0	0	0	0	0	0	0	0	0	0	0	0	0	0	0	0	0	0	0	0	0	0	0	
ID	R/W	Field	Value ID	Value	Description																											
A	R	Status			Status of register DATA																											
			NoDataPending	0	No data pending in register TXDATA																											
			DataPending	1	Data pending in register TXDATA																											

9.8.5.1.9 MAILBOX.RXDATA

Address offset: 0x028

Data sent from the CPU to the debugger.

Reading from this register will automatically set a NoDataPending value in the RXSTATUS register.

Bit number	31	30	29	28	27	26	25	24	23	22	21	20	19	18	17	16	15	14	13	12	11	10	9	8	7	6	5	4	3	2	1	0
ID	A	A	A	A	A	A	A	A	A	A	A	A	A	A	A	A	A	A	A	A	A	A	A	A	A	A	A	A	A	A	A	
Reset	0	0	0	0	0	0	0	0	0	0	0	0	0	0	0	0	0	0	0	0	0	0	0	0	0	0	0	0	0	0	0	
ID	R/W	Field	Value ID	Value	Description																											
A	R	Data			Data sent from CPU																											

9.8.5.1.10 MAILBOX.RXSTATUS

Address offset: 0x02C

This register shows a status that indicates if data sent from the CPU to the debugger has been read.

Bit number	31	30	29	28	27	26	25	24	23	22	21	20	19	18	17	16	15	14	13	12	11	10	9	8	7	6	5	4	3	2	1	0
ID																																A
Reset 0x00000000	0 0																															
ID	R/W	Field	Value ID	Value	Description																											
A	R	Status			Status of register DATA																											
			NoDataPending	0	No data pending in register RXDATA																											
			DataPending	1	Data pending in register RXDATA																											

9.8.5.1.11 IDR

Address offset: 0x0FC

CTRL-AP Identification Register, IDR

Bit number	31	30	29	28	27	26	25	24	23	22	21	20	19	18	17	16	15	14	13	12	11	10	9	8	7	6	5	4	3	2	1	0
ID	E	E	E	E	D	D	D	D	C	C	C	C	C	C	B	B	B	B							A	A	A	A	A	A	A	A
Reset 0x12880000	0 0 0 1 0 0 1 0 1 0 0 0 1 0																															
ID	R/W	Field	Value ID	Value	Description																											
A	R	APID			AP Identification																											
B	R	CLASS	NotDefined	0x0	No defined class																											
			MEMAP	0x8	Memory Access Port																											
C	R	JEP106ID			JEDEC JEP106 identity code																											
D	R	JEP106CONT			JEDEC JEP106 continuation code																											
E	R	REVISION			Revision																											

9.8.6 Registers

Instances

Instance	Base address	TrustZone			Split access	Description
		Map	Att	DMA		
CTRL_AP_PERI	0x50006000	HF	S	NA	No	CTRL-AP-PERI

Register overview

Register	Offset	TZ	Description
MAILBOX.RXDATA	0x400		Data sent from the debugger to the CPU.
MAILBOX.RXSTATUS	0x404		This register shows a status that indicates if data sent from the debugger to the CPU has been read.
MAILBOX.TXDATA	0x480		Data sent from the CPU to the debugger.
MAILBOX.TXSTATUS	0x484		This register shows a status that indicates if the data sent from the CPU to the debugger has been read.
ERASEPROTECT.LOCK	0x500		This register locks the ERASEPROTECT.DISABLE register from being written until next reset.
ERASEPROTECT.DISABLE	0x504		This register disables the ERASEPROTECT register and performs an ERASEALL operation.

9.8.6.1 MAILBOX.RXDATA

Address offset: 0x400

Data sent from the debugger to the CPU.

Reading from this register will automatically set a NoDataPending value in the RXSTATUS register.

Bit number	31	30	29	28	27	26	25	24	23	22	21	20	19	18	17	16	15	14	13	12	11	10	9	8	7	6	5	4	3	2	1	0
ID	A	A	A	A	A	A	A	A	A	A	A	A	A	A	A	A	A	A	A	A	A	A	A	A	A	A	A	A	A	A	A	A
Reset 0x00000000	0	0	0	0	0	0	0	0	0	0	0	0	0	0	0	0	0	0	0	0	0	0	0	0	0	0	0	0	0	0	0	
ID	R/W	Field	Value ID	Value	Description																											
A	R	RXDATA			Data received from debugger																											

9.8.6.2 MAILBOX.RXSTATUS

Address offset: 0x404

This register shows a status that indicates if data sent from the debugger to the CPU has been read.

Bit number	31	30	29	28	27	26	25	24	23	22	21	20	19	18	17	16	15	14	13	12	11	10	9	8	7	6	5	4	3	2	1	0
ID																																A
Reset 0x00000000	0	0	0	0	0	0	0	0	0	0	0	0	0	0	0	0	0	0	0	0	0	0	0	0	0	0	0	0	0	0	0	
ID	R/W	Field	Value ID	Value	Description																											
A	R	RXSTATUS			Status of data in register RXDATA																											
			NoDataPending	0	No data pending in register RXDATA																											
			DataPending	1	Data pending in register RXDATA																											

9.8.6.3 MAILBOX.TXDATA

Address offset: 0x480

Data sent from the CPU to the debugger.

Writing to this register will automatically set a DataPending value in the TXSTATUS register.

Bit number	31	30	29	28	27	26	25	24	23	22	21	20	19	18	17	16	15	14	13	12	11	10	9	8	7	6	5	4	3	2	1	0
ID	A	A	A	A	A	A	A	A	A	A	A	A	A	A	A	A	A	A	A	A	A	A	A	A	A	A	A	A	A	A	A	
Reset 0x00000000	0	0	0	0	0	0	0	0	0	0	0	0	0	0	0	0	0	0	0	0	0	0	0	0	0	0	0	0	0	0	0	
ID	R/W	Field	Value ID	Value	Description																											
A	RW	TXDATA			Data sent to debugger																											

9.8.6.4 MAILBOX.TXSTATUS

Address offset: 0x484

This register shows a status that indicates if the data sent from the CPU to the debugger has been read.

Bit number	31	30	29	28	27	26	25	24	23	22	21	20	19	18	17	16	15	14	13	12	11	10	9	8	7	6	5	4	3	2	1	0
ID																																A
Reset 0x00000000	0	0	0	0	0	0	0	0	0	0	0	0	0	0	0	0	0	0	0	0	0	0	0	0	0	0	0	0	0	0	0	
ID	R/W	Field	Value ID	Value	Description																											
A	R	TXSTATUS			Status of data in register TXDATA																											
			NoDataPending	0	No data pending in register TXDATA																											
			DataPending	1	Data pending in register TXDATA																											

9.8.6.5 ERASEPROTECT.LOCK

Address offset: 0x500

This register locks the ERASEPROTECT.DISABLE register from being written until next reset.

Bit number	31	30	29	28	27	26	25	24	23	22	21	20	19	18	17	16	15	14	13	12	11	10	9	8	7	6	5	4	3	2	1	0
ID	A																															
Reset 0x00000000	0 0																															
ID	R/W	Field	Value ID	Value	Description																											
A	RW1	LOCK			Lock ERASEPROTECT.DISABLE register from being written until next reset																											
			Unlocked	0	Register ERASEPROTECT.DISABLE is writeable																											
			Locked	1	Register ERASEPROTECT.DISABLE is read-only																											

9.8.6.6 ERASEPROTECT.DISABLE

Address offset: 0x504

This register disables the ERASEPROTECT register and performs an ERASEALL operation.

Bit number	31	30	29	28	27	26	25	24	23	22	21	20	19	18	17	16	15	14	13	12	11	10	9	8	7	6	5	4	3	2	1	0
ID	A	A	A	A	A	A	A	A	A	A	A	A	A	A	A	A	A	A	A	A	A	A	A	A	A	A	A	A	A	A	A	
Reset 0x00000000	0 0																															
ID	R/W	Field	Value ID	Value	Description																											
A	RW1	KEY			The ERASEALL sequence is initiated if the value of the KEY fields are non-zero and the KEY fields match on both the CPU and debugger sides.																											

9.9 TAD - Trace and debug control

Configuration interface for trace and debug

Please refer to the [Trace](#) section for more information about how to configure the trace and debug interface.

Note: Although there are PSEL registers for the trace port, each function can only be mapped to a single pin due to pin speed requirements. Setting the PIN field to anything else will not have any effect. See [Pin assignment chapter](#) for more information

9.9.1 Registers

Instances

Instance	Base address	TrustZone			Split access	Description
		Map	Att	DMA		
TAD	0xE0080000	HF	S	NA	No	Trace and debug control

Register overview

Register	Offset	TZ	Description
TASKS_CLOCKSTART	0x000		Start all trace and debug clocks.
TASKS_CLOCKSTOP	0x004		Stop all trace and debug clocks.
ENABLE	0x500		Enable debug domain and acquire selected GPIOs
PSEL.TRACECLK	0x504		Pin configuration for TRACECLK
PSEL.TRACEDATA0	0x508		Pin configuration for TRACEDATA[0]
PSEL.TRACEDATA1	0x50C		Pin configuration for TRACEDATA[1]
PSEL.TRACEDATA2	0x510		Pin configuration for TRACEDATA[2]
PSEL.TRACEDATA3	0x514		Pin configuration for TRACEDATA[3]
TRACEPORTSPEED	0x518		Clocking options for the Trace Port debug interface

Reset behavior is the same as debug components

This register is retained.

9.9.1.1 TASKS_CLOCKSTART

Address offset: 0x000

Start all trace and debug clocks.

Note: The TASKS_CLOCKSTART task asserts the CTRL/STAT.CSYSPWRUPACK and CTRL/STAT.CDBGPWRUPACK (see *Arm CoreSight SoC-400 Technical Reference Manual, revision r3p2*).

Bit number	31	30	29	28	27	26	25	24	23	22	21	20	19	18	17	16	15	14	13	12	11	10	9	8	7	6	5	4	3	2	1	0	
ID																																	A
Reset 0x00000000	0 0																																
ID	R/W	Field	Value ID	Value	Description																												
A	W	TASKS_CLOCKSTART			Start all trace and debug clocks.																												

Note: The TASKS_CLOCKSTART task asserts the CTRL/STAT.CSYSPWRUPACK and CTRL/STAT.CDBGPWRUPACK (see *Arm CoreSight SoC-400 Technical Reference Manual, revision r3p2*).

Trigger

1

Trigger task

9.9.1.2 TASKS_CLOCKSTOP

Address offset: 0x004

Stop all trace and debug clocks.

Bit number	31	30	29	28	27	26	25	24	23	22	21	20	19	18	17	16	15	14	13	12	11	10	9	8	7	6	5	4	3	2	1	0	
ID																																	A
Reset 0x00000000	0 0																																
ID	R/W	Field	Value ID	Value	Description																												
A	W	TASKS_CLOCKSTOP			Stop all trace and debug clocks.																												
		Trigger		1	Trigger task																												

9.9.1.3 ENABLE

Address offset: 0x500

Enable debug domain and acquire selected GPIOs

Bit number	31	30	29	28	27	26	25	24	23	22	21	20	19	18	17	16	15	14	13	12	11	10	9	8	7	6	5	4	3	2	1	0
ID																																A
Reset	0x00000000																															
Reset	0	0	0	0	0	0	0	0	0	0	0	0	0	0	0	0	0	0	0	0	0	0	0	0	0	0	0	0	0	0	0	0
ID	R/W	Field	Value ID	Value	Description																											
A	RW	ENABLE																														
			DISABLED	0	Disable debug domain and release selected GPIOs																											
			ENABLED	1	Enable debug domain and acquire selected GPIOs																											

9.9.1.4 PSEL.TRACECLK

Address offset: 0x504

Pin configuration for TRACECLK

Bit number	31	30	29	28	27	26	25	24	23	22	21	20	19	18	17	16	15	14	13	12	11	10	9	8	7	6	5	4	3	2	1	0
ID	B																				A				A	A	A	A				
Reset	0xFFFFFFFF																															
Reset	1	1	1	1	1	1	1	1	1	1	1	1	1	1	1	1	1	1	1	1	1	1	1	1	1	1	1	1	1	1	1	
ID	R/W	Field	Value ID	Value	Description																											
A	RW	PIN			Pin number																											
			Traceclk	21	TRACECLK pin																											
					Note: Only this pin is valid																											
B	RW	CONNECT			Connection																											
			Disconnected	1	Disconnect																											
			Connected	0	Connect																											

9.9.1.5 PSEL.TRACEDATA0

Address offset: 0x508

Pin configuration for TRACEDATA[0]

Bit number	31	30	29	28	27	26	25	24	23	22	21	20	19	18	17	16	15	14	13	12	11	10	9	8	7	6	5	4	3	2	1	0
ID	B																				A				A	A	A	A				
Reset	0xFFFFFFFF																															
Reset	1	1	1	1	1	1	1	1	1	1	1	1	1	1	1	1	1	1	1	1	1	1	1	1	1	1	1	1	1	1	1	
ID	R/W	Field	Value ID	Value	Description																											
A	RW	PIN			Pin number																											
			Tracedata0	22	TRACEDATA0 pin																											
					Note: Only this pin is valid																											
B	RW	CONNECT			Connection																											
			Disconnected	1	Disconnect																											
			Connected	0	Connect																											

9.9.1.6 PSEL.TRACEDATA1

Address offset: 0x50C

Pin configuration for TRACEDATA[1]

Bit number	31 30 29 28 27 26 25 24 23 22 21 20 19 18 17 16 15 14 13 12 11 10 9 8 7 6 5 4 3 2 1 0																																		
ID	B																												A			A	A	A	A
Reset 0xFFFFFFFF	1 1																																		
ID	R/W	Field	Value ID	Value	Description																														
A	RW	PIN			Pin number																														
			Tracedata1	23	TRACEDATA1 pin																														
Note: Only this pin is valid																																			
B	RW	CONNECT			Connection																														
			Disconnected	1	Disconnect																														
			Connected	0	Connect																														

9.9.1.7 PSEL.TRACEDATA2

Address offset: 0x510

Pin configuration for TRACEDATA[2]

Bit number	31 30 29 28 27 26 25 24 23 22 21 20 19 18 17 16 15 14 13 12 11 10 9 8 7 6 5 4 3 2 1 0																																		
ID	B																												A			A	A	A	A
Reset 0xFFFFFFFF	1 1																																		
ID	R/W	Field	Value ID	Value	Description																														
A	RW	PIN			Pin number																														
			Tracedata2	24	TRACEDATA2 pin																														
Note: Only this pin is valid																																			
B	RW	CONNECT			Connection																														
			Disconnected	1	Disconnect																														
			Connected	0	Connect																														

9.9.1.8 PSEL.TRACEDATA3

Address offset: 0x514

Pin configuration for TRACEDATA[3]

Bit number	31 30 29 28 27 26 25 24 23 22 21 20 19 18 17 16 15 14 13 12 11 10 9 8 7 6 5 4 3 2 1 0																																		
ID	B																												A			A	A	A	A
Reset 0xFFFFFFFF	1 1																																		
ID	R/W	Field	Value ID	Value	Description																														
A	RW	PIN			Pin number																														
			Tracedata3	25	TRACEDATA3 pin																														
Note: Only this pin is valid																																			
B	RW	CONNECT			Connection																														
			Disconnected	1	Disconnect																														
			Connected	0	Connect																														

9.9.1.9 TRACEPORTSPEED (Retained)

Address offset: 0x518

Clocking options for the Trace Port debug interface

Reset behavior is the same as debug components

This register is retained.

Bit number	31	30	29	28	27	26	25	24	23	22	21	20	19	18	17	16	15	14	13	12	11	10	9	8	7	6	5	4	3	2	1	0
ID																															A	A
Reset	0x00000000																															
	0	0	0	0	0	0	0	0	0	0	0	0	0	0	0	0	0	0	0	0	0	0	0	0	0	0	0	0	0	0	0	0

ID	R/W	Field	Value ID	Value	Description
A	RW	TRACEPORTSPEED			Speed of Trace Port clock. Note that the TRACECLK pin output will be divided again by two from the Trace Port clock.
			32MHz	0	Trace Port clock is: 32MHz
			16MHz	1	Trace Port clock is: 16MHz
			8MHz	2	Trace Port clock is: 8MHz
			4MHz	3	Trace Port clock is: 4MHz

10 Hardware and layout

The following sections describe nRF9160 hardware and layout specifications.

10.1 Pin assignments

This section describes the pin assignment and the pin functions of the nRF9160.

The device provides flexibility when it comes to routing and configuration of the GPIO pins. However, for some pins there are recommendations on pin usage and configuration. See [LGA pin assignments](#) on page 511 for more information about this.

10.1.1 LGA pin assignments

The pin assignment table and figure describe the assignments.

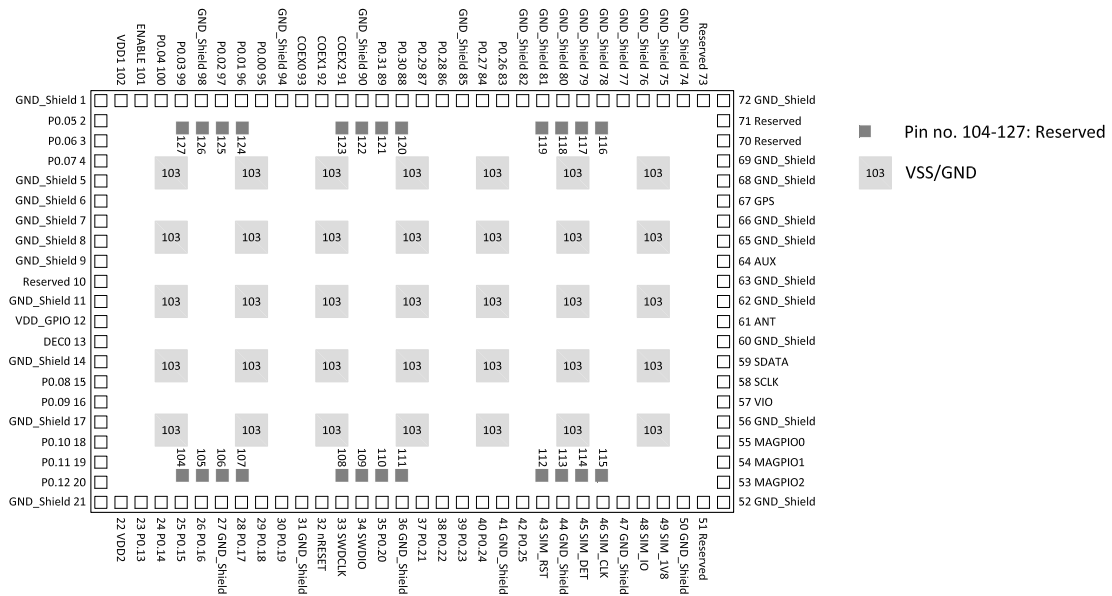

Figure 122: LGA pin assignments, top view

Pin no	Pin name	Function	Description
1	GND_Shield	Power	Ground
2	P0.05	Digital I/O (SoC)	General purpose I/O
3	P0.06	Digital I/O (SoC)	General purpose I/O
4	P0.07	Digital I/O (SoC)	General purpose I/O
5	GND_Shield	Power	Ground
6	GND_Shield	Power	Ground
7	GND_Shield	Power	Ground
8	GND_Shield	Power	Ground
9	GND_Shield	Power	Ground
10	Reserved		Do not connect/reserved for future use
11	GND_Shield	Power	Ground
12	VDD_GPIO	Power	GPIO power supply input and logic level
13	DECO	Power	Power supply decoupling. Reserved for Nordic use.
14	GND_Shield	Power	Ground

Pin no	Pin name	Function	Description
15	P0.08	Digital I/O (SoC)	General purpose I/O
16	P0.09	Digital I/O (SoC)	General purpose I/O
17	GND_Shield	Power	Ground
18	P0.10	Digital I/O (SoC)	General purpose I/O
19	P0.11	Digital I/O (SoC)	General purpose I/O
20	P0.12	Digital I/O (SoC)	General purpose I/O
21	GND_Shield	Power	Ground
22	VDD2	Power	Supply voltage input
23	P0.13	Digital I/O (SoC)	General purpose I/O.
	AIN0	Analog input	Analog input.
24	P0.14	Digital I/O (SoC)	General purpose I/O.
	AIN1	Analog input	Analog input.
25	P0.15	Digital I/O (SoC)	General purpose I/O.
	AIN2	Analog input	Analog input.
26	P0.16	Digital I/O (SoC)	General purpose I/O.
	AIN3	Analog input	Analog input.
27	GND_Shield	Power	Ground
28	P0.17	Digital I/O (SoC)	General purpose I/O.
	AIN4	Analog input	Analog input.
29	P0.18	Digital I/O (SoC)	General purpose I/O.
	AIN5	Analog input	Analog input.
30	P0.19	Digital I/O (SoC)	General purpose I/O.
	AIN6	Analog input	Analog input.
31	GND_Shield	Power	Ground
32	nRESET	Digital I/O (SoC)	SoC system reset ^{22,23}
33	SWDCLK	Digital input	Serial wire debug clock input for debug and programming
34	SWDIO	Digital I/O	Serial wire debug I/O for debug and programming
35	P0.20	Digital I/O (SoC)	General purpose I/O.
	AIN7	Analog input	Analog input.
36	GND_Shield	Power	Ground
37	P0.21	Digital I/O (SoC)	General purpose I/O.
	TRACECLK	Trace clock	Trace buffer clock (optional).
38	P0.22	Digital I/O (SoC)	General purpose I/O.
	TRACEDATA0	Trace data	Trace buffer TRACEDATA[0] (optional).
39	P0.23	Digital I/O (SoC)	General purpose I/O.
	TRACEDATA1	Trace data	Trace buffer TRACEDATA[1] (optional).
40	P0.24	Digital I/O (SoC)	General purpose I/O.
	TRACEDATA2	Trace data	Trace buffer TRACEDATA[2] (optional).
41	GND_Shield	Power	Ground
42	P0.25	Digital I/O (SoC)	General purpose I/O.
	TRACEDATA3	Trace data	Trace buffer TRACEDATA[3] (optional).
43	SIM_RST	Digital I/O (SoC)	SIM reset
44	GND_Shield	Power	Ground
45	SIM_DET	Digital I/O (SoC)	SIM detect

Not used. Must be left floating.

²² External pull-up not allowed.

²³ For implementations that require the ERASEALL functionality, enable access to the nRESET pin. See [Erase all](#) on page 499 for more information.

Pin no	Pin name	Function	Description
46	SIM_CLK	Digital I/O (SoC)	SIM clock
47	GND_Shield	Power	Ground
48	SIM_IO	Digital I/O (SoC)	SIM data
49	SIM_1V8	Power	SIM 1.8 V power supply output
50	GND_Shield	Power	Ground
51	Reserved		Do not connect/reserved for future use
52	GND_Shield	Power	Ground
53	MAGPIO2	Digital I/O (SoC)	1.8 V general purpose I/O
54	MAGPIO1	Digital I/O (SoC)	1.8 V general purpose I/O
55	MAGPIO0	Digital I/O (SoC)	1.8 V general purpose I/O
56	GND_Shield	Power	Ground
57	VIO	Power	MIPI RFFE control interface
58	SCLK	Digital I/O (SoC)	MIPI RFFE control interface
59	SDATA	Digital I/O (SoC)	MIPI RFFE control interface
60	GND_Shield	Power	Ground
61	ANT	RF	Single-ended 50 Ω LTE antenna pin
62	GND_Shield	Power	Ground
63	GND_Shield	Power	Ground
64	AUX	RF	Single-ended 50 Ω ANT loop-back pin
65	GND_Shield	Power	Ground
66	GND_Shield	Power	Ground
67	GPS	RF	Single-ended 50 Ω GPS input pin
68	GND_Shield	Power	Ground
69	GND_Shield	Power	Ground
70	Reserved		Do not connect/reserved for future use
71	Reserved		Do not connect/reserved for future use
72	GND_Shield	Power	Ground
73	Reserved		Do not connect/reserved for future use
74	GND_Shield	Power	Ground
75	GND_Shield	Power	Ground
76	GND_Shield	Power	Ground
77	GND_Shield	Power	Ground
78	GND_Shield	Power	Ground
79	GND_Shield	Power	Ground
80	GND_Shield	Power	Ground
81	GND_Shield	Power	Ground
82	GND_Shield	Power	Ground
83	P0.26	Digital I/O (SoC)	General purpose I/O
84	P0.27	Digital I/O (SoC)	General purpose I/O
85	GND_Shield	Power	Ground
86	P0.28	Digital I/O (SoC)	General purpose I/O
87	P0.29	Digital I/O (SoC)	General purpose I/O
88	P0.30	Digital I/O (SoC)	General purpose I/O
89	P0.31	Digital I/O (SoC)	General purpose I/O
90	GND_Shield	Power	Ground
91	COEX2	Digital I/O (SoC)	Coexistence interface
92	COEX1	Digital I/O (SoC)	Coexistence interface
93	COEX0	Digital I/O (SoC)	Coexistence interface
94	GND_Shield	Power	Ground
95	P0.00	Digital I/O (SoC)	General purpose I/O
96	P0.01	Digital I/O (SoC)	General purpose I/O
97	P0.02	Digital I/O (SoC)	General purpose I/O
98	GND_Shield	Power	Ground

Pin no	Pin name	Function	Description
99	P0.03	Digital I/O (SoC)	General purpose I/O
100	P0.04	Digital I/O (SoC)	General purpose I/O
101	ENABLE		Enable for the SiP internal regulator for the nRF91 SoC.
Note: The nRF91 will not start until this pin is high.			
102	VDD1	Power	Supply voltage
103	VSS	Power	Ground
104-127	Reserved		Do not connect/reserved for future use

Table 54: LGA pin assignments

10.2 Mechanical specifications

The mechanical specifications show the package dimensions in millimeters.

10.2.1 16.0 x 10.5 mm package

Dimensions in millimeters for the nRF9160 LGA 16.0 x 10.5 x 1.04 mm package.

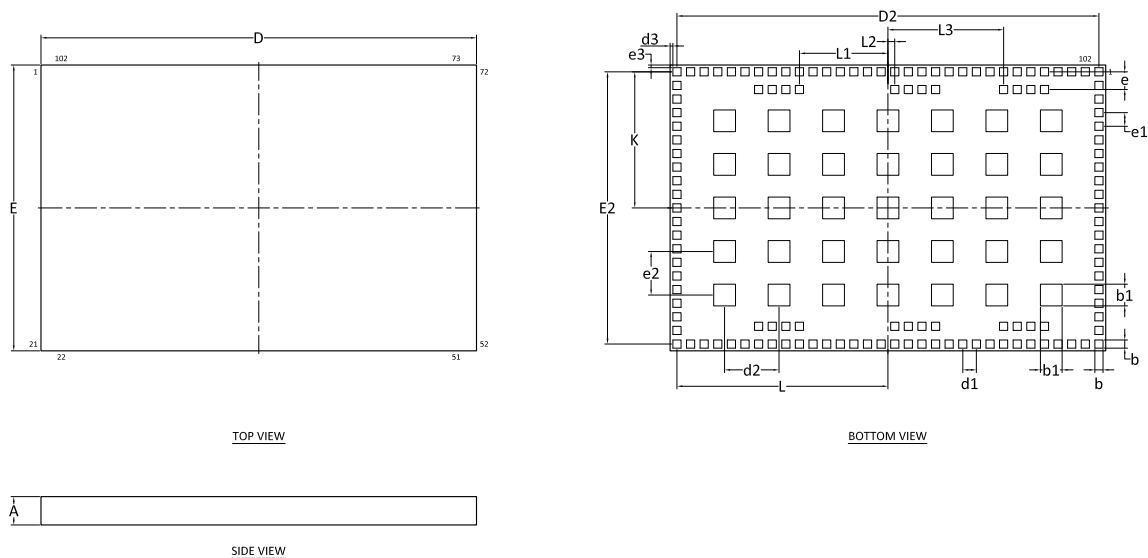

Figure 123: LGA 16.0 x 10.5 mm package

	A	b	b1	D	E	e	d1	e1	D2	E2	d2	e2	d3	e3	K	L	L1	L2	L3
Min.	0.98			15.90	10.40														
Nom.	1.04	0.30	0.80	16.00	10.50	0.65	0.50	0.50	15.50	10.00	2.00	1.60	0.10	0.10	5.00	7.75	3.25	0.25	4.25
Max.	1.10			16.10	10.60														

Table 55: LGA dimensions in millimeters

10.3 Reference circuitry

To ensure good RF performance when designing PCBs, using the PCB layouts and component values provided by Nordic Semiconductor is highly recommended .

Documentation for the different package reference circuits, including Altium Designer files, PCB layout files, and PCB production files can be downloaded from the product page at www.nordicsemi.com.

Designator	Value	Description	Footprint
C1, C7	15 pF	Capacitor, NPO, ± 0.1 pF, 25 V	0201
C2, C4, C8, C10	100 nF	Capacitor, X5R, $\pm 10\%$	0201
C3, C9	47 μ F	Capacitor, X5R, $\pm 20\%$, 10 V	0805
C5	4.7 μ F	Capacitor, X5R, $\pm 20\%$	0402
C6	4.7 μ F	Capacitor, X5R, $\pm 10\%$, 16 V	0805
R1	10 k Ω	Resistor, $\pm 1\%$, 0.05 W	0201
R2	1 k	Resistor, $\pm 1\%$, 0.05 W	0201
FB1	120 R / 0.70 A	Ferrite Bead, 120 Ω @ 100 MHz, 700 mA, 130 m Ω Max	0402
U1	nRF9160-SixA	Low power System-in-Package (SiP) with integrated LTE-M/NB-IoT modem and GPS	LGA

Table 56: BOM for SixA LGA127

For PCB reference layouts, see the product page for the nRF9160 at www.nordicsemi.com.

10.4 Reflow conditions

The recommended reflow profile is JEDEC J-STD-020D. The maximum amount of reflows is three.

10.5 Shelf and floor life

If floor life is exceeded, see [Shelf Life of Dry Packed Integrated Circuits](#) for shelf and floor life and recommended baking (drying of parts) requirements.

11 Operating conditions

The operating conditions are the physical parameters that the chip can operate within.

Symbol	Parameter	Notes	Min.	Nom.	Max.	Units
VDD	Battery input voltage	Including voltage drop, ripple and spikes.	3.0	3.7	5.5	V
		RF 3GPP limited temperature -10°C to 55°C	3.1	3.7	5.5	V
		RF Product Specification operating temperature	3.3	3.7	5.5	V
VDD_GPIO	GPIO input voltage		1.7	3.6	V	
GPIO _H	GPIO high level voltage				VDD_GPIO	V
MAGPIO _H	MAGPIO high level voltage	Supply from internal LDO	1.7	1.8	1.9	V
VIO	VIO high level voltage	Supply from internal LDO	1.7	1.8	1.9	V
TA	Operating temperature		-40	25	85	°C
COEX	COEX high level voltage				VDD_GPIO	V
SIMIF	SIMIF output high level voltage	Supply from internal LDO	1.7	1.8	1.9	V

Table 57: Operating conditions

Note: There can be excessive leakage at VDD and/or VDD_GPIO if any of these supply voltages is outside its range given in the table above.

Note: It is not recommended to use high voltage, high drive GPIO outputs ($V_{OH,HDH}$ and $V_{OH,HDL}$) with high frequency, high capacitance loads unless needed, as this may increase noise level and affect radio receiver performance. High drive/high load should especially be avoided on GPIO pins close to the radio front end.

11.1 VDD_GPIO considerations

VDD_GPIO is the supply to the general purpose I/O.

The following restrictions should be taken into considerations:

- VDD_GPIO should be applied after VDD has been supplied
- VDD_GPIO should be removed before removing VDD
- If VDD is supplied and VDD_GPIO is grounded, an extra current consumption can be generated on VDD
- If ENABLE is low, VDD_GPIO should also be low

12 Absolute maximum ratings

Maximum ratings are the extreme limits to which the chip can be exposed for a limited amount of time without permanently damaging it. Exposure to absolute maximum ratings for prolonged periods of time may affect the reliability of the device.

	Note	Min.	Max.	Unit
Supply voltages				
VDD		-0.3	5.5 ²⁴	V
VDD_GPIO		-0.3	3.9	V
SIM_1V8		1.65	1.95	V
VSS			0	V
I/O pin voltage				
$V_{I/O}$, VDD_GPIO ≤ 3.6 V		-0.3	VDD_GPIO + 0.3	V
$V_{I/O}$, VDD_GPIO > 3.6 V		-0.3	3.9	V
Radio				
ANT antenna input level			10	dBm
GPS antenna input level	LNA turned on, max gain		-15	dBm
RF port ruggedness	Maximum deviation from 50 Ω without damaging the module		10:1	VSWR
Environmental (LGA package)				
Storage temperature		-40	95	°C
MSL	Moisture Sensitivity Level		3	
ESD HBM	Human Body Model		1.5	kV
ESD HBM Class	Human Body Model Class		1C	
ESD CDM	Charged Device Model		250	V
Flash memory				
Endurance		10 000		Write/erase cycles
Retention		10 years at 85°C		
ATEX compliance				
Ci			83	μF
Li			9.0	μH
Ui			5.0	V
Ii			600	mA
Thermal conductivity			35	C/W
No internal voltage boost converters				

Table 58: Absolute maximum ratings

²⁴ ATEX compliance requires a maximum of 5.0 V.

13 Ordering information

This chapter contains information on IC marking, ordering codes, and container sizes.

13.1 SiP marking

The nRF9160 package is marked as shown in the following figure.

n	R	F	9	1	6	0		<P	P>	<V	V>	<H>	<P>
								<Y	Y>	<W	W>	<L	L>

Figure 125: SiP package marking

13.2 Box labels

The following figures show the box labels used for the nRF9160.

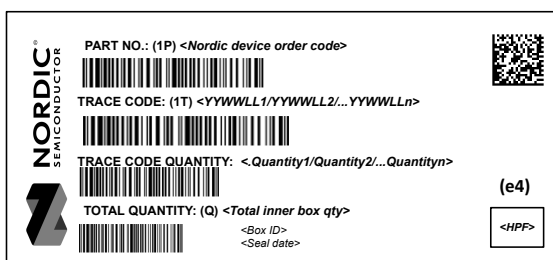

Figure 126: Inner box label









	
FROM: <div style="border: 1px solid gray; height: 40px; width: 100%;"></div>	TO: <div style="border: 1px solid gray; height: 40px; width: 100%;"></div>
PART NO: (1P) <Nordic device order code>  <div style="float: right; border: 1px solid black; padding: 2px;"><H><P><F></div>	
CUSTOMER PO NO: (K) <Customer Purchase Order No.>  <div style="float: right; border: 1px solid black; border-radius: 50%; padding: 2px;">PB</div>	
SALES ORDER NO: (14K) <Nordic Sales Order+Sales order line no.+ Delivery line no.> 	
SHIPMENT ID.: 2K <Nordic's shipment ID.> 	
QUANTITY: (Q) <Total quantity> 	
COUNTRY OF ORIGIN.: 4L <2- character code of COO> 	CARTON NO: x/n
DELIVERY NO.: (9K) <Shipper's shipment no.> 	GROSS WEIGHT: <div style="border: 1px solid gray; display: inline-block; width: 30px; height: 15px;"></div> KGS 

Figure 127: Outer box label

13.3 Order code

The following are the order codes and definitions for the nRF9160.

n	R	F	9	1	6	0	-	<P	P>	<V	V>	-	<H>	<P>	<F>	-	<C	C>
---	---	---	---	---	---	---	---	----	----	----	----	---	-----	-----	-----	---	----	----

Figure 128: Order code

Abbreviation	Definition and implemented codes
N91/nRF91	nRF91 Series product
60	Part code
<PP>	Package variant code
<VV>	Function variant code
<H><P><F>	Build code H - Hardware version code P - Production configuration code (production site, etc.) F - Firmware version code (only visible on shipping container label)
<YY><WW><LL>	Tracking code YY - Year code WW - Assembly week number LL - Wafer lot code
<CC>	Container code

Table 59: Abbreviations

13.4 Code ranges and values

The nRF9160 code ranges and values are defined here.

<PP>	Package	Size (mm)	Pin/Ball count	Pitch (mm)
SI	LGA	16.00 x 10.50	127	0.50

Table 60: Package variant codes

<VV>	LTE-M/NB-IoT/GPS	Flash (kB)	RAM (kB)
CA	LTE-M/NB-IoT/GPS	1024	256
AA	LTE-M only		

Table 61: Function variant codes

<H>	Description
[A . . Z]	Hardware version/revision identifier (incremental)

Table 62: Hardware version codes

<P>	Description
[0 . . 9]	Production device identifier (incremental)
[A . . Z]	Engineering device identifier (incremental)

Table 63: Production configuration codes

<F>	Description
[A . . N, P . . Z]	Version of preprogrammed firmware
[0]	Delivered without preprogrammed firmware

Table 64: Production version codes

<YY>	Description
[15 . . 99]	Production year: 2015 to 2099

Table 65: Year codes

<WW>	Description
[01 . . 53]	Week of production

Table 66: Week codes

<LL>	Description
[AA . . ZZ]	Wafer production lot identifier

Table 67: Lot codes

<CC>	Description
R7	7" Reel
R	13" Reel

Table 68: Container codes

13.5 Product options

The nRF9160 SiP ordering codes and minimum ordering quantity are described in the following table.

Order code	Minimum ordering quantity (MOQ)	Comment
nRF9160-SICA-B1A-R	2500	LTE-M/NB-IoT/GPS product
nRF9160-SICA-B1A-R7	100	LTE-M/NB-IoT/GPS product
nRF9160-SIAA-B1A-R	2500	LTE-M only product
nRF9160-SIAA-B1A-R7	100	LTE-M only product

Table 69: nRF9160 order codes

Order code	Description
nRF9160-DK	nRF9160 Development Kit
nRF6943	Nordic Thingy:91

Table 70: Development tools order code

14 Regulatory information

The nRF9160 undergoes regulatory certifications, ensuring both regional compliances and compatibility with the LTE 3GPP specification.

For information on certified bands and certification status, see [nRF9160 Certifications](#).

15 Legal notices

By using this documentation you agree to our terms and conditions of use. Nordic Semiconductor may change these terms and conditions at any time without notice.

Liability disclaimer

Nordic Semiconductor ASA reserves the right to make changes without further notice to the product to improve reliability, function, or design. Nordic Semiconductor ASA does not assume any liability arising out of the application or use of any product or circuits described herein.

Nordic Semiconductor ASA does not give any representations or warranties, expressed or implied, as to the accuracy or completeness of such information and shall have no liability for the consequences of use of such information. If there are any discrepancies, ambiguities or conflicts in Nordic Semiconductor's documentation, the Product Specification prevails.

Nordic Semiconductor ASA reserves the right to make corrections, enhancements, and other changes to this document without notice.

Customer represents that, with respect to its applications, it has all the necessary expertise to create and implement safeguards that anticipate dangerous consequences of failures, monitor failures and their consequences, and lessen the likelihood of failures that might cause harm, and to take appropriate remedial actions.

Nordic Semiconductor ASA assumes no liability for applications assistance or the design of customers' products. Customers are solely responsible for the design, validation, and testing of its applications as well as for compliance with all legal, regulatory, and safety-related requirements concerning its applications.

Nordic Semiconductor ASA's products are not designed for use in life-critical medical equipment, support appliances, devices, or systems where malfunction of Nordic Semiconductor ASA's products can reasonably be expected to result in personal injury. Customer may not use any Nordic Semiconductor ASA's products in life-critical medical equipment unless adequate design and operating safeguards by customer's authorized officers have been made. Customer agrees that prior to using or distributing any life-critical medical equipment that include Nordic Semiconductor ASA's products, customer will thoroughly test such systems and the functionality of such products as used in such systems.

Customer will fully indemnify Nordic Semiconductor ASA and its representatives against any damages, costs, losses, and/or liabilities arising out of customer's non-compliance with this section.

RoHS and REACH statement

Refer to www.nordicsemi.com for complete hazardous substance reports, material composition reports, and latest version of Nordic's RoHS and REACH statements.

Trademarks

All trademarks, service marks, trade names, product names, and logos appearing in this documentation are the property of their respective owners.



Copyright notice

© 2024 Nordic Semiconductor ASA. All rights are reserved. Reproduction in whole or in part is prohibited without the prior written permission of the copyright holder.







Looking for pricing, stock, or lifecycle information?

Click below to explore more details on WIN SOURCE:

-  [View NRF9160-SIAA-B1A-R7 on WIN SOURCE](#)
-  [Nordic Semiconductors Information](#)

Optimize Your Supply Chain with WIN SOURCE Solutions

-  Global Sourcing Solution
-  Obsolete Management
-  Cost Control Management
-  Shortage Management
-  Alternative Solution
-  Excess Inventory Management