

BQ296xxx Overvoltage Protection for 2-Series, 3-Series, and 4-Series Cell Li-Ion Batteries with Regulated Output Supply

1 Features

- 2-series, 3-series, and 4-series cell overvoltage protection (OVP)
- Fixed delay timer to trigger FET drive output (3-s, 4-s, 5.5-s, or 6.5-s options)
- Factory programmed OVP threshold (threshold range 3.85V to 4.6V)
- Output options: active high
- High-accuracy overvoltage protection: $\pm 10\text{mV}$
- Regulated supply output with self-disable and/or external enable/disable control
 - Options: 3.3V, 2.5V, and 1.8V (BQ2961)
 - Options: 3.3V, 3.15V, 3.0V (BQ2962)
- Low power consumption $I_{CC} \sim 4\mu\text{A}$ ($V_{CELL(ALL)} < V_{PROTECT}$)
- Extra low power consumption with reg output disabled, $I_{CC} \sim 1.2\mu\text{A}$
- Low leakage current per cell input $< 100\text{nA}$
- Small package footprint
 - 8-Pin WSON (2mm \times 2mm)

2 Applications

- [Notebook PC](#)
- [Ultrabooks](#)
- [Medical](#)
- [UPS battery backup](#)

3 Description

The BQ296xxx family is a high-accuracy, low-power overvoltage protector with a 2mA regulated output supply for Li-ion battery pack applications.

Each cell in a 2-series to 4-series cell stack is individually monitored for an overvoltage condition. An internally fixed-delay timer is initiated upon detection of an overvoltage condition on any cell. Upon expiration of the delay timer, an output pin is triggered into an active state to indicate that an overvoltage condition has occurred.

The regulated output supply delivers up to 2mA (max) output current to drive always-on circuits, such as a real-time clock (RTC) oscillator. The BQ296xxx family has a self-disable function to turn off the regulated output if any cell voltage falls below a certain threshold, thereby preventing drain on the battery, and provides an external control to enable or disable the regulated output.

Package Information

PART NUMBER	PACKAGE (1)	BODY SIZE (NOM)
BQ2961	WSON (8)	2.00mm \times 2.00mm
BQ2962		

(1) For all available packages, see the orderable addendum at the end of the data sheet.

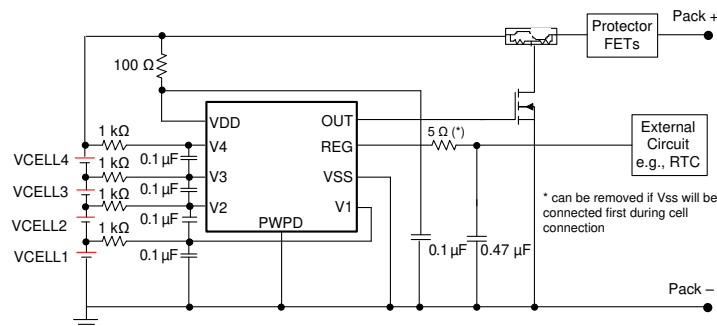

Simplified Schematic



Table of Contents

1 Features	1	8 Application and Implementation	14
2 Applications	1	8.1 Application Information.....	14
3 Description	1	8.2 Typical Application.....	14
4 Device Comparison Table	3	9 Power Supply Recommendations	17
5 Pin Configuration and Functions	4	10 Layout	17
6 Specifications	5	10.1 Layout Guidelines.....	17
6.1 Absolute Maximum Ratings.....	5	10.2 Layout Example.....	17
6.2 ESD Ratings.....	5	11 Device and Documentation Support	18
6.3 Recommended Operating Conditions.....	5	11.1 Device Support.....	18
6.4 Thermal Information.....	5	11.2 Receiving Notification of Documentation Updates..	18
6.5 Electrical Characteristics.....	6	11.3 Support Resources.....	18
6.6 Typical Characteristics.....	8	11.4 Trademarks.....	18
7 Detailed Description	9	11.5 Electrostatic Discharge Caution.....	18
7.1 Overview.....	9	11.6 Glossary.....	18
7.2 Functional Block Diagram.....	10	12 Revision History	19
7.3 Feature Description.....	10	13 Mechanical, Packaging, and Orderable	
7.4 Device Functional Modes.....	11	Information	19

4 Device Comparison Table

Table 4-1. BQ2961 Device Options

BQ2961	OVP (V)	OVP DELAY (s)	UV (V)	LDO (V)
BQ296100	4.35	6.5	2.5	3.3
BQ296103	4.50	6.5	2.5	3.3
BQ296106	4.45	6.5	2.8	3.3
BQ296107	4.50	6.5	2.8	3.3
BQ296111	4.45	4.0	2.5	3.3
BQ296112	4.50	3.0	2.5	3.3
BQ296113	4.35	3.0	2.5	3.3
BQ296114	4.50	4.0	2.5	3.3
BQ296115	4.25	6.5	2.0	2.5
BQ296116 ⁽¹⁾	4.50	6.5	2.5	1.8
BQ2961 ⁽¹⁾	3.85V–4.60V (50mV step)	3.0, 4.0, 5.5, 6.5	2.0V–2.8V (50mV step)	1.8, 2.5, 3.3

(1) PRODUCT PREVIEW. Contact TI for more information.

Table 4-2. BQ2962 Device Options

BQ2962	OVP (V)	OVP DELAY (s)	UV (V)	LDO (V)
BQ296202	4.45	6.5	2.5	3.3
BQ296203	4.50	6.5	2.5	3.3
BQ296212	4.50	3.0	2.5	3.3
BQ296213	4.35	3.0	2.5	3.3
BQ296215	4.50	6.5	2.5	3.0
BQ296216	4.55	6.5	2.5	3.0
BQ296217	4.55	6.5	2.8	3.3
BQ296221	4.55	6.5	2.5	3.3
BQ296222	4.50	6.5	3.0	3.0
BQ296223	4.50	6.5	2.5	3.3
BQ296224	4.50	6.5	2.5	3.0
BQ296226	4.50	6.5	2.8	3.3
BQ296227	4.55	6.5	2.8	3.3
BQ296228	4.55	6.5	2.5	3.0
bq296229	4.60	6.5	2.5	3.0
BQ296230	4.35	6.5	3.0	3.0
BQ296231	4.60	6.5	2.5	3.3
BQ296232	4.55	6.5	3.0	3.0
BQ296233	4.45	6.5	2.5	3.3
BQ296234	4.60	6.5	3.0	3.0
BQ296235	4.45	4	2.03	3.3
BQ2962 ⁽¹⁾	3.85V–4.60V (50mV step)	3.0, 4.0, 5.5, 6.5	2.0V–3.5V (50mV step)	3, 3.15, 3.3

(1) PRODUCT PREVIEW. Contact TI for more information.

5 Pin Configuration and Functions

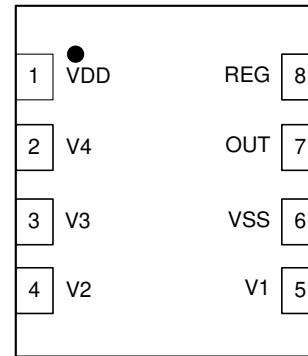
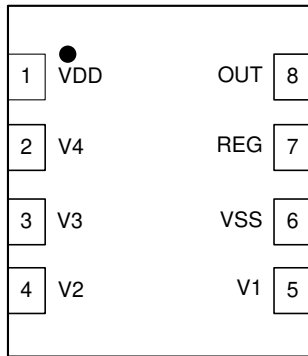

Figure 5-1. 2-Series to 4-Series BQ2961 (Top View) Figure 5-2. 2-Series to 4-Series BQ2962 (Top View)

Table 5-1. Pin Functions

PIN		BQ2962	TYPE ⁽¹⁾	DESCRIPTION
NAME	BQ2961			
OUT	8	7	OA	Analog output drive for an overvoltage fault signal; CMOS output high or open-drain active low
PWPD	9	9	P	TI recommends connecting the exposed pad to VSS on PCB.
REG	7	8	OA	Regulated supply output. Requires an external ceramic capacitor for stability
V1	5	5	IA	Sense input for positive voltage of the lowest cell from the bottom of the stack
V2	4	4	IA	Sense input for positive voltage of the second cell from the bottom of the stack
V3	3	3	IA	Sense input for positive voltage of the third cell from the bottom of the stack
V4	2	2	IA	Sense input for positive voltage of the fourth cell from the bottom of the stack
VDD	1	1	P	Power supply input
VSS	6	6	P	Electrically connected to integrated circuit ground and negative terminal of the lowest cell in the stack

(1) IA = Analog input, OA = Analog Output, P = Power connection

6 Specifications

6.1 Absolute Maximum Ratings

Over operating free-air temperature range (unless otherwise noted)⁽¹⁾

		MIN	MAX	UNIT
Supply voltage	VDD – VSS	–0.3	30	V
Input voltage	V4 – V3, V3 – V2, V2 – V1, V1 – VSS	–0.3	30	
	REG – VSS	–0.3	3.6	
Output voltage	OUT – VSS	–0.3	30	
Continuous total power dissipation, P _{TOT}		See Section 6.4 .		
Lead temperature (soldering, 10 s), T _{SOLDER}		300	300	°C
Storage temperature, T _{stg}		–65	150	°C

- (1) Operation outside the *Absolute Maximum Ratings* may cause permanent device damage. Absolute Maximum Ratings do not imply functional operation of the device at these or any other conditions beyond those listed under *Recommended Operating Conditions*. If outside the Recommended Operating Conditions but within the Absolute Maximum Ratings, the device may not be fully functional, and this may affect device reliability, functionality, performance, and shorten the device lifetime.

6.2 ESD Ratings

		VALUE	UNIT
V _(ESD) Electrostatic discharge	Human body model (HBM), per ANSI/ESDA/JEDEC JS-001 ⁽¹⁾	2000	V
	Charged device model (CDM), per JEDEC specification JESD22-C101 ⁽²⁾	500	

- (1) JEDEC document JEP155 states that 500V HBM allows safe manufacturing with a standard ESD control process.
(2) JEDEC document JEP157 states that 250V CDM allows safe manufacturing with a standard ESD control process.

6.3 Recommended Operating Conditions

Over operating free-air temperature range (unless otherwise noted).

		MIN	NOM	MAX	UNIT
Supply voltage, V _{DD} ⁽¹⁾	Supply voltage, V _{DD} ⁽¹⁾	3		20	V
	Supply voltage, V _{DD} with REG output on	4			
Input voltage range	V _n – V _{n-1} , V1 – VSS	0		5	V
Operating ambient temperature range, T _A		–40		110	°C

- (1) See [Section 8.2](#).

6.4 Thermal Information

THERMAL METRIC ⁽¹⁾		BQ296xxx	UNIT
		DSG (WSON)	
		8 PINS	
R _{θJA}	Junction-to-ambient thermal resistance	62	°C/W
R _{θJC(top)}	Junction-to-case(top) thermal resistance	72	°C/W
R _{θJB}	Junction-to-board thermal resistance	32.5	°C/W
Ψ _{JT}	Junction-to-top characterization parameter	1.6	°C/W
Ψ _{JB}	Junction-to-board characterization parameter	33	°C/W
R _{θJC(bot)}	Junction-to-case(bottom) thermal resistance	10	°C/W

- (1) For more information about traditional and new thermal metrics, see the [Semiconductor and IC Package Thermal Metrics](#) application note.

6.5 Electrical Characteristics

Typical values stated where $T_A = 25^\circ\text{C}$ and $V_{DD} = 14.4\text{V}$, MIN/MAX values stated where $T_A = -40^\circ\text{C}$ to $+110^\circ\text{C}$, and $V_{DD} = 3\text{V}$ to 15V (unless otherwise noted).

PARAMETER		TEST CONDITIONS	MIN	TYP	MAX	UNIT
Voltage Protection Thresholds						
V_{OV}	$V_{(PROTECT)}$ Overvoltage Detection	$R_{IN} = 1\text{ k}\Omega$	Applicable Voltage: 3.85V to 4.6V in 50mV steps			V
V_{HYS}	OV Detection Hysteresis		250	300	400	mV
V_{OA}	OV Detection Accuracy	$T_A = 25^\circ\text{C}$	-10		10	mV
$V_{OADRIFT}$	OV Detection Accuracy Across Temperature	$T_A = -40^\circ\text{C}$	-40		40	mV
		$T_A = 0^\circ\text{C}$	-20		20	mV
		$T_A = 60^\circ\text{C}$	-24		24	mV
		$T_A = 110^\circ\text{C}$	-54		54	mV
		$T_A = 110^\circ\text{C}$	-54		54	mV
Supply and Leakage Current						
I_{DD}	Supply Current with REG on	$(V_n - V_{n-1}) = 2\text{V}$ to 4.15V , $n = 1$ to 4 , $V_{DD} = \text{top } V_n$ voltage $(V_1 - V_{SS}) > V_{UVREG}$, $I_{REG} = 0\text{mA}$,	$T_A = 0^\circ\text{C}$ to 60°C	4	6	μA
			$T_A = -40^\circ\text{C}$ to 110°C		8	μA
I_{DD}	Supply Current with REG off	$(V_n - V_{n-1}) = 2\text{V}$ to 4.15V , $n = 1$ to 4 , $V_{DD} = \text{top } V_n$ voltage $(V_1 - V_{SS}) < V_{UVREG}$	$T_A = 0^\circ\text{C}$ to 60°C	1	2	μA
			$T_A = -40^\circ\text{C}$ to 110°C		4	μA
I_{IN}	Input Current at V_x Pins	$(V_n - V_{n-1}) = (V_1 - V_{SS}) = 3.8\text{V}$, $V_{DD} = \text{top } V_n$ voltage, $T_A = 25^\circ\text{C}$	-0.1		0.1	μA
Output Drive OUT, CMOS Active High						
V_{OUT}	Output Drive Voltage, Active High	$(V_n - V_{n-1})$ or $(V_1 - V_{SS}) > V_{OV}$, $I_{OH} = 100\mu\text{A}$, $V_{DD} = \text{top } V_n$ voltage	6	7	8	V
		If three of four cells are short circuited, only one cell remains powered and $> V_{OV}$, $V_{DD} = V_n$ (the remaining cell voltage), $I_{OH} = 100\mu\text{A}$		$V_{DD} - 0.3$		V
		$(V_n - V_{n-1})$ and $(V_1 - V_{SS}) < V_{OV}$, $V_{DD} = \text{sum of the cell stack voltage}$, $I_{OL} = 100\mu\text{A}$ measured into OUT pin		250	400	mV
I_{OUTH}	OUT Source Current (during OV)	$(V_n - V_{n-1})$, $(V_3 - V_2)$, or $(V_1 - V_{SS}) > V_{OV}$, $V_{DD} = \text{top } V_n$ voltage, forced OUT = 0V, measured out of OUT pin			4.5	mA
I_{OUTL}	OUT Sink Current (no OV)	$(V_n - V_{n-1})$ and $(V_1 - V_{SS}) < V_{OV}$, $V_{DD} = \text{top } V_n$ voltage, forced OUT = VDD, measured into OUT pin. Pull-up resistor $R_{PU} = 5\text{k}\Omega$ to VDD	0.5		14	mA
Internal Fixed Delay Timer						
t_{DELAY}	OV Delay Time ⁽¹⁾	Internal Fixed Delay, 3-s delay option	2.4	3	3.6	s
		Internal Fixed Delay, 4-s delay option	3.2	4	4.8	s
		Internal Fixed Delay, 5.5-s delay option	4.4	5.5	6.6	s
		Internal Fixed Delay, 6.5-s delay option	5.2	6.5	7.8	s
t_{DELAY_CTM}	Fault Detection Delay Time in Test Mode OV Delay Time	Internal Fixed Delay		15		ms
t_{DELAY_RESET}	OV delay timer count reset time; t_{DELAY} resets when the cell voltage falls below V_{OV} for t_{DELAY_RESET} . ⁽¹⁾	Internal Fixed Delay		0.6		ms

6.5 Electrical Characteristics (continued)

Typical values stated where $T_A = 25^\circ\text{C}$ and $V_{DD} = 14.4\text{V}$, MIN/MAX values stated where $T_A = -40^\circ\text{C}$ to $+110^\circ\text{C}$, and $V_{DD} = 3\text{V}$ to 15V (unless otherwise noted).

PARAMETER		TEST CONDITIONS	MIN	TYP	MAX	UNIT	
Regulated Supply Output, REG							
V_{REG}	REG Supply at 500 μA load	$V_{DD} \geq 4\text{V}$, $I_{REG} = 500\mu\text{A}$, $C_{REG} = 0.47\mu\text{F}$	$V_{REG} = 3.3\text{V}$,	3.234	3.300	3.366	V
			$V_{REG} = 3.15\text{V}$, BQ2962	3.087	3.150	3.213	
			$V_{REG} = 3.0\text{V}$, BQ2962	2.940	3.000	3.060	
			$V_{REG} = 2.5\text{V}$, BQ2961	2.450	2.500	2.550	
			$V_{REG} = 1.8\text{V}$, BQ2961	1.764	1.800	1.836	
V_{REG}	REG Supply from 0 to 2mA load	$V_{DD} \geq 4\text{V}$, $I_{REG} = 0\mu\text{A}$ to 2mA, $C_{REG} = 0.47\mu\text{F}$	$V_{REG} = 3.3\text{V}$, BQ2961, BQ2962	3.200	3.300	3.400	V
			$V_{REG} = 3.15\text{V}$, BQ2962	3.050	3.150	3.250	
			$V_{REG} = 3.0\text{V}$, BQ2962	2.900	3.000	3.100	
			$V_{REG} = 2.5\text{V}$, BQ2961	2.425	2.500	2.575	
			$V_{REG} = 1.8\text{V}$, BQ2961	1.746	1.800	1.854	
I_{REG}	REG Current Output	$V_{DD} \geq 4\text{V}$, $C_{REG} = 0.47\mu\text{F}$	0		2	mA	
$I_{REG_SC_Limit}$	REG Output Short Circuit Current Limit	$REG = V_{SS}$, $C_{REG} = 0.47\mu\text{F}$	4			mA	
R_{REG_PD}	REG pull-down resistor	REG is disabled.	20	30	45	k Ω	
Regulated Supply Undervoltage Self-Disable							
V_{UVREG}	Undervoltage detection	Factory Configuration: 2.0V to 3.5V in 50mV steps, $T_A = 25^\circ\text{C}$	-50		50	mV	
V_{UVHYS}	Undervoltage Detection Hysteresis		250	300	400	mV	
$t_{UVDELAY}$	Undervoltage Detection Delay		4.5	6	7.5	s	
V_{UVQUAL}	Cell voltage to qualify for UV detection			0.5		V	

(1) Specified by design. Not 100% tested in production.

6.6 Typical Characteristics

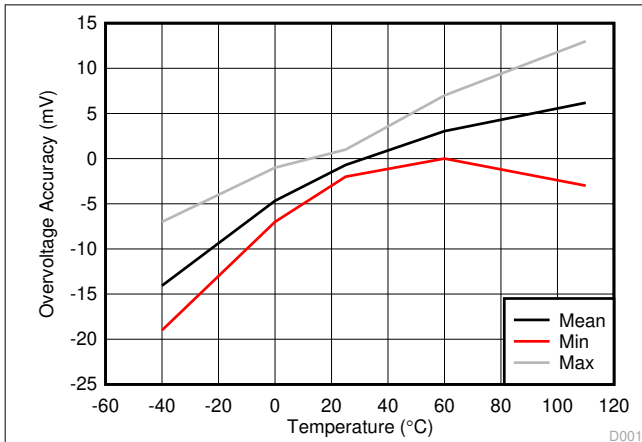

Figure 6-1. Overvoltage Threshold (V_{OV}) vs. Temperature

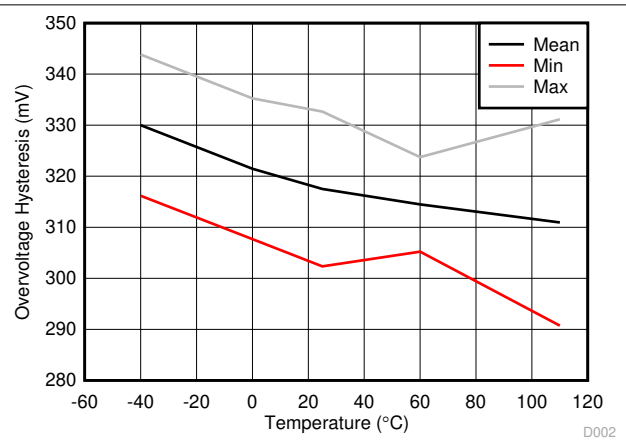

Figure 6-2. Hysteresis V_{HYS} vs. Temperature

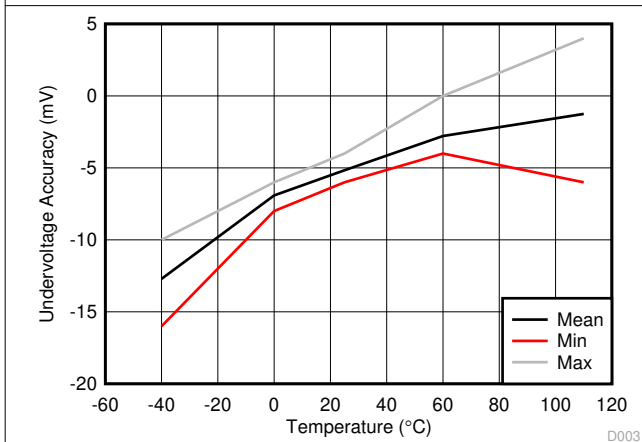

Figure 6-3. Undervoltage Accuracy

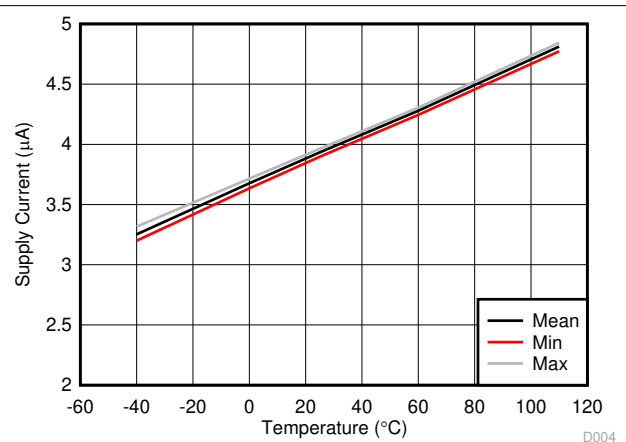

Figure 6-4. I_{DD} with Regulator On

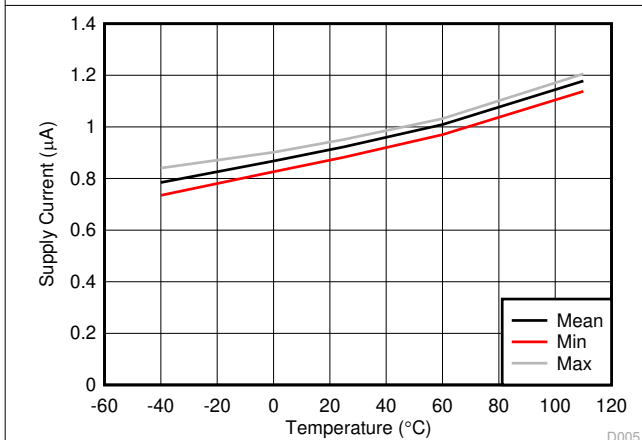

Figure 6-5. I_{DD} with Regulator Off

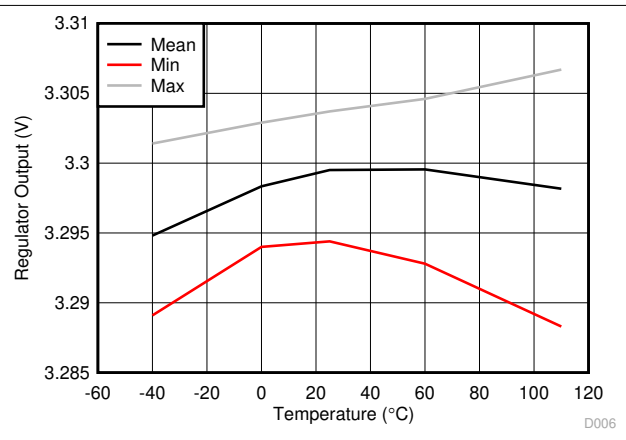
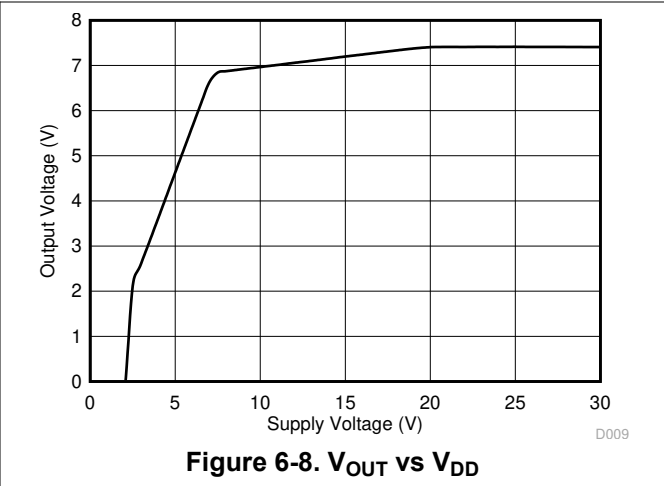
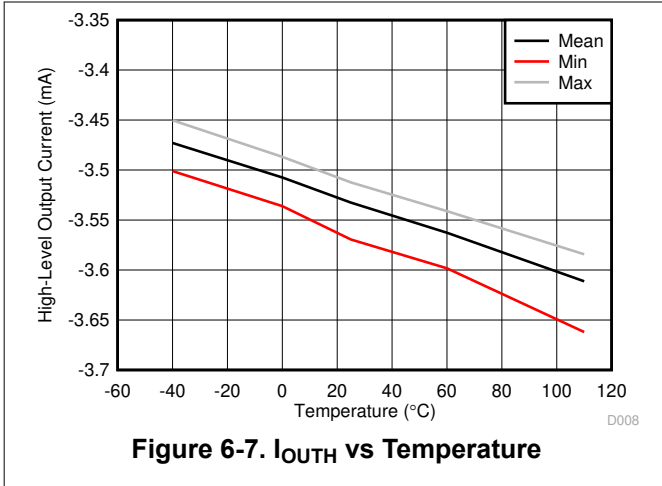

Figure 6-6. Regulator Output Without Load



7 Detailed Description

7.1 Overview

The BQ2961 and BQ2962 devices are second-level overvoltage (OV) protectors with a regulated output. Each cell is monitored independently by comparing the actual cell voltage to an overvoltage threshold V_{OV} . The overvoltage threshold is preprogrammed at the factory with a range between 3.85V to 4.65V.

The regulated output is enabled unless any of the cell voltages fall below the V_{UVREG} threshold. This threshold is preprogrammed at the factory with a range between 2V to 2.8 (3.5V for future BQ2962 options).

Table 7-1. Programmable Parameters

OVERVOLTAGE RANGE (V)	OVERVOLTAGE DELAY (s)	UNDERVOLTAGE RANGE (V)	REGULATOR (V)
3.85 to 4.6 in 50mV steps	3, 4, 5.5, 6.5	2.0 to 2.8 (3.5 for future BQ2962 options) in 50-mV steps	1.8, 2.5, 3.3 (BQ2961) 3.0, 3.15, 3.3 (BQ2962)

7.2 Functional Block Diagram

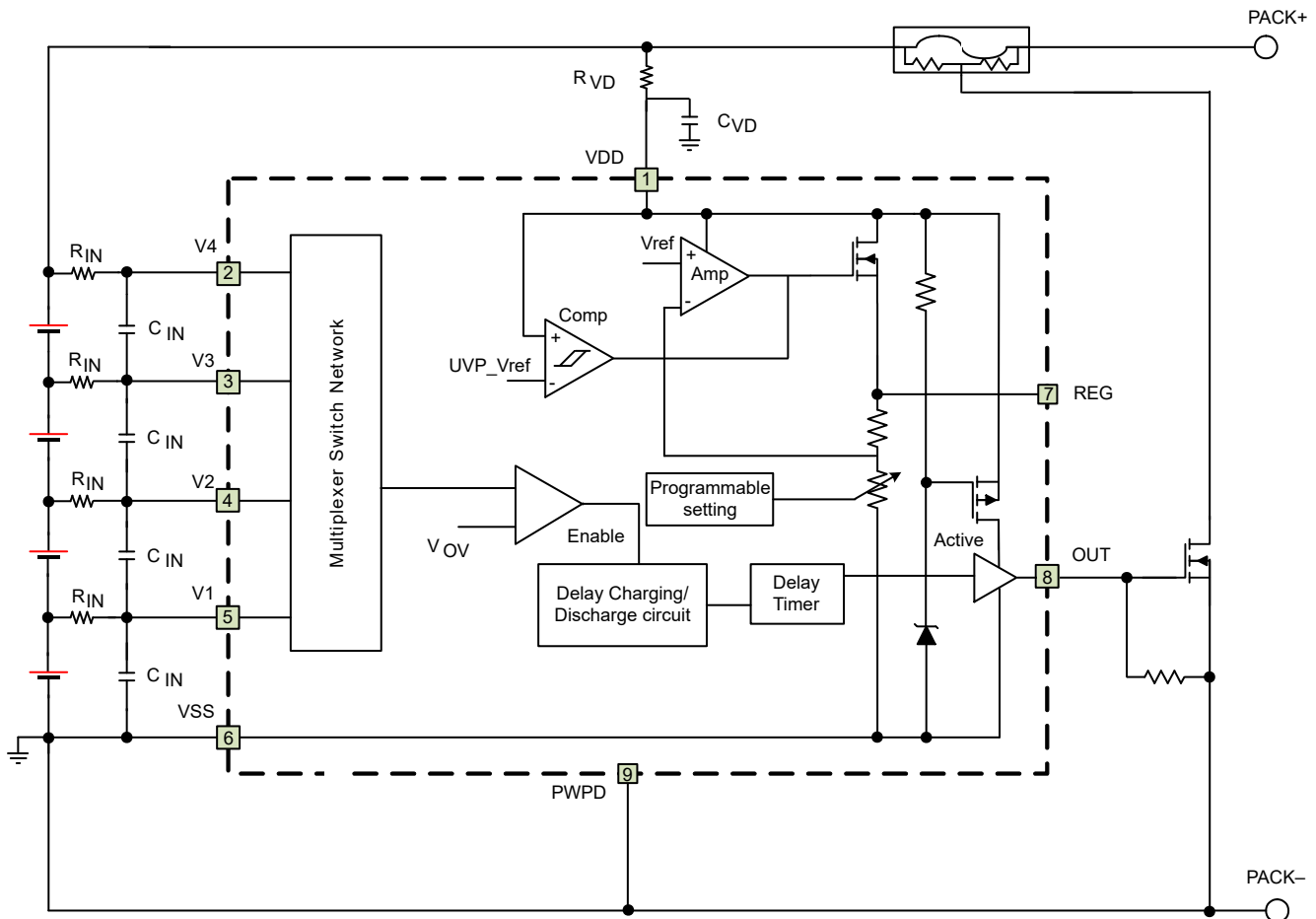

7.3 Feature Description

7.3.1 Pin Details

7.3.1.1 Input Sense Voltage, V_x

These inputs sense each battery cell voltage. A series resistor and a capacitor across the cell for each input is required for noise filtering and stable voltage monitoring.

7.3.1.2 Output Drive, OUT

This terminal serves as the fault signal output in active high.

7.3.1.3 Supply Input, VDD

This terminal is the unregulated input power source for the device. A series resistor is connected to limit the current, and a capacitor is connected to ground for noise filtering.

7.3.1.4 Regulated Supply Output, REG

This terminal is connected to an external capacitor and provides a regulated supply to power a circuit such as a real-time clock integrated circuit, or functions requiring a well-regulated supply. Maximum current load on this pin cannot exceed I_{REG} mA.

The REG output has protection for overcurrent, using a current limit protection circuit, and also detects and protects for excessive power dissipation due to short circuit of the external load. This pin requires a ceramic 1µF capacitor connection to VSS for improved stability, noise immunity, and ESD performance of the supply output. This capacitor must be placed close to the REG and VSS pins for connection.

7.3.2 Overvoltage Sensing for OUT

In the BQ296xxx device, each cell is monitored independently. Overvoltage is detected by comparing the actual cell voltage to a protection voltage reference, V_{OV} . If any cell voltage exceeds the programmed OV value, an internal timer circuit is activated. This timer circuit causes a factory pre-programmed fixed delay before the OUT terminal goes from inactive to active state.

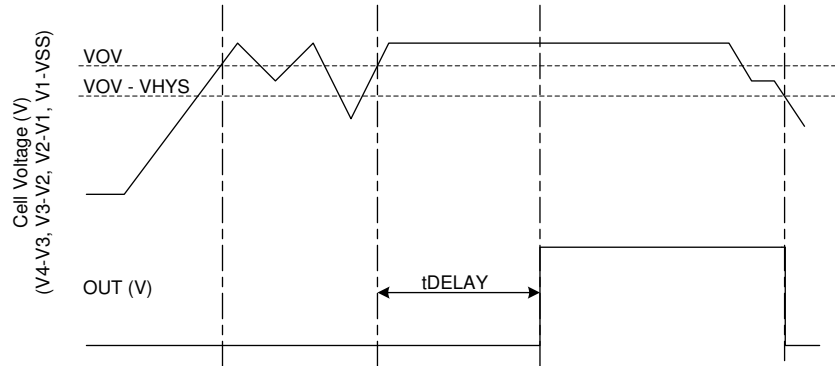

Figure 7-1. Timing for Overvoltage Sensing for OUT

7.3.3 Regulated Output Voltage

For BQ2961, there are three factory-preprogrammed options for the regulated output voltage, 3.3V, 2.5V, and 1.8V. For BQ2962, the regulated output voltage options are 3.3V, 3.15V, and 3.0V. Potentially, the BQ2962xy device can provide other regulated voltage output between 3.3V to 3.0V. Contact Texas Instruments for details.

At power up, the regulated output is on by default. If any cell voltage is below V_{UVREG} at device power up, the regulated output will remain on until the t_{UV_DELAY} time has passed, the regulated output turns off after the delay time.

During discharge, if any cell voltage falls below the V_{UVREG} threshold for t_{UV_DELAY} time, the regulated output is self-disabled. The regulated output turns on again when all the cell voltages are above $V_{UVREG} + V_{UVHYS}$.

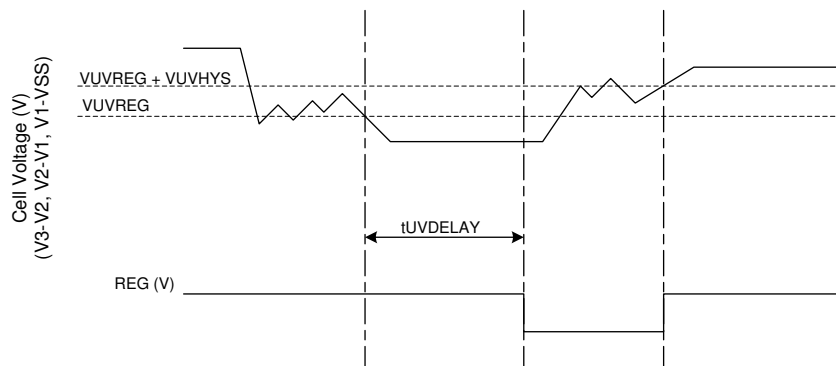

Figure 7-2. REG Output Timing

7.4 Device Functional Modes

7.4.1 NORMAL Mode

When all of the cell voltages are below the V_{OV} threshold AND above V_{UVREG} threshold, the device operates in NORMAL mode. The device monitors the differential cell voltages connected across (V1–VSS), (V2–V1), (V3–V2), and (V4–V3). The OUT pin is inactive in this mode. The regulated output is always enabled for BQ2961.

7.4.2 OVERVOLTAGE Mode

OVERVOLTAGE mode is detected if any of the cell voltages exceed the overvoltage threshold, V_{OV} , for a configured OV delay time. The OUT pin is activated after a delay time preprogrammed at the factory. The OUT pin will pull high internally. Then an external FET is turned on, shorting the fuse to ground, which allows the battery and/or charger power to blow the fuse. When all of the cell voltages fall below $(V_{OV} - V_{HYS})$, the device returns to NORMAL mode. The regulated output (if enabled) remains on in this mode.

7.4.3 UNDERVOLTAGE Mode

The UNDERVOLTAGE mode is detected if any of the cell voltage across $(V1-VSS)$, $(V2-V1)$, $(V3-V2)$, or $(V4-V3)$ is below the V_{UVREG} threshold for t_{UV_DELAY} time. In this mode, the regulated output is disabled. To return to the NORMAL mode, all the cell voltages must be above $(V_{UVREG} + V_{UVHYS})$.

For a low cell configuration, V_n pin can be shorted to the $(V_n - 1)$ pin. The device ignores any differential cell voltage below V_{UVQUAL} threshold for undervoltage detection.

7.4.4 CUSTOMER TEST Mode

The Customer Test Mode (CTM) helps to reduce test time for checking the overvoltage delay-timer parameter once the circuit is implemented into the battery pack. To enter CTM, the VDD pin should be set at least 10V higher than V4 (see Figure 7-3). The delay timer is greater than 10ms, but considerably shorter than the timer delay in normal operation. To exit CTM, remove the VDD to V4 voltage differential of 10V, so that the decrease in the value automatically causes an exit.

CAUTION

Avoid exceeding any Absolute Maximum Voltages on any pins when placing the device into CTM. Also avoid exceeding Absolute Maximum Voltages for the individual cell voltages $(V4-V3)$, $(V3-V2)$, $(V2-V1)$ and $(V1-VSS)$. Stressing the pins beyond the rated limits can cause permanent damage to the device.

Figure 7-3 shows the timing for the Customer Test Mode.

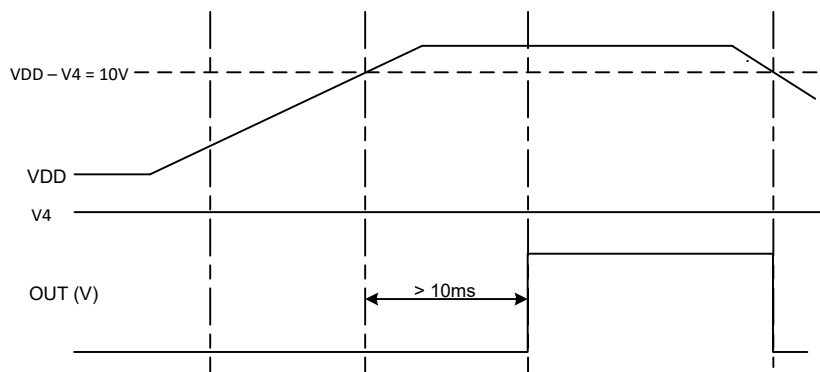

Figure 7-3. Timing for Customer Test Mode

Figure 7-4 shows the measurement for current consumption of the product for both VDD and Vx.

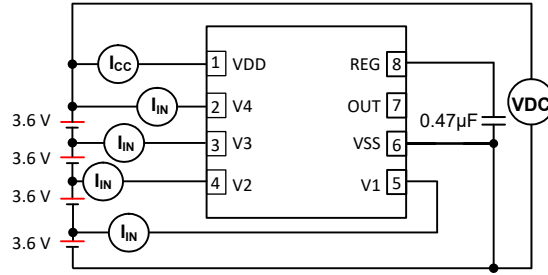

Figure 7-4. Configuration for Integrated Circuit Current Consumption Test

8.2.2 Detailed Design Procedure

Note

The device VSS must be connected first during PCB test or cell attachment. Failure to do so can damage the REG pin.

1. If the VSS pin cannot be connected first, it is required to add a resistor of a minimum of 5Ω to a maximum of 10Ω (a 5Ω resistor is used in the reference schematic, [Figure 8-2](#)) in series with the REG capacitor. When VSS is floating, the REG capacitor always charges up to the VDD voltage. When VSS is finally connected, the REG capacitor will be discharged. Adding a small resistor in series reduces the current strength and avoids any potential damage to the REG pin. The 5Ω resistor can be placed in series with the REG connect circuit (as shown in [Figure 8-2](#)) or in series of the REG capacitor (as shown in [Figure 8-3](#)). Placing the resistor in series with the REG circuit results in a small drop of V_{REG} (for example: max loading of I_{REG} mA with a 5Ω resistor will drop 5mV on V_{REG}), but such a connection can protect against rush current discharge from a REG capacitor or an external filter capacitor connected to the REG pin. Placing the resistor in series with the REG capacitor is an alternative to avoiding an additional drop in V_{REG} if the filter capacitor used by the external circuit is much smaller than the REG capacitor.
2. After VSS is connected, the device allows a random cell connection to the Vx pin.
3. The cell should be connected to the lower V_n pin; the unused V_n pin should be shorted to the (V_{n-1}) pin. See [Figure 8-2](#) for details.

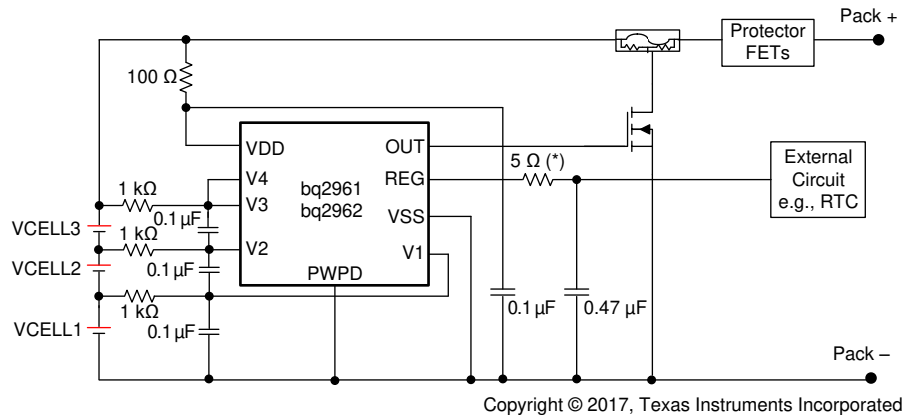
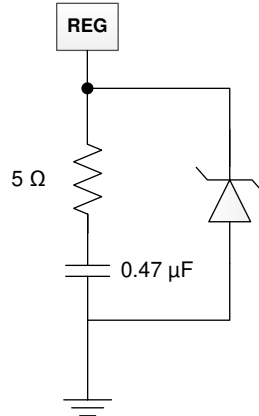

Figure 8-2. 3-Series BQ2961 and BQ2962 Schematic

4. A Zener diode can be added to the REG pin to VSS, as shown in [Figure 8-3](#). This is recommended to protect the circuit connected to the REG pin if floating VSS in the field is a risk concern. When VSS is floating (during cell connection when VSS is not connected first or in a system fault with a broken BAT- wire), the REG voltage always pulls up to VDD. In a 4-series configuration, the REG voltage can reach approximately 16V with VSS floating. Adding a Zener diode clamps the REG voltage to a safe level for the external circuits connected to the REG pin. Having the Zener diode can also protect the external circuits if the REG pin is shorted to the OUT pin or any other high-voltage output terminal. If a Zener diode is used, TI recommends putting the diode on the battery side with the BQ296xxx device to allow protection on the REG pin, as well as the circuit connected to REG under the floating VSS condition. The resistor in series with the REG pin is not required in this case.

The 5-Ω resistor limits the rush current discharge from the capacitor during cell connection when Vss is not connected first.

This resistor is not required if Vss is connected first in the cell connection sequence.



Loss of Vss connection or REG shorted to high voltage can bring the REG above the regulated range. This optional zener clamp can protect the downstream circuit under such an event.

Figure 8-3. 5V Zener Diode

8.2.3 Application Curves

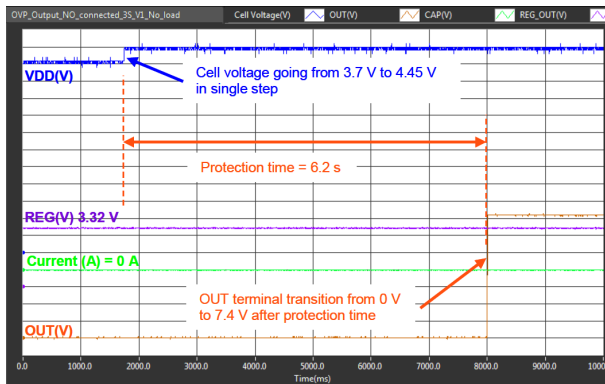

Figure 8-4. Overvoltage Protection

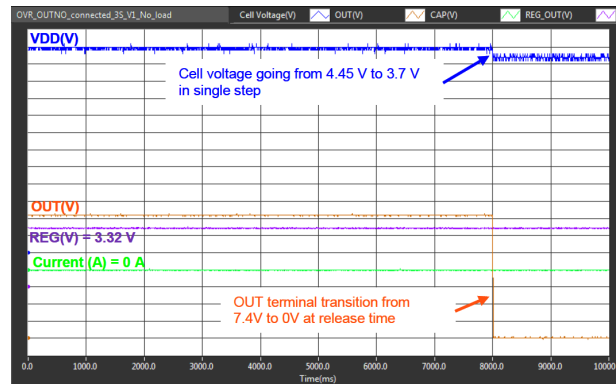

Figure 8-5. Overvoltage Protection Release

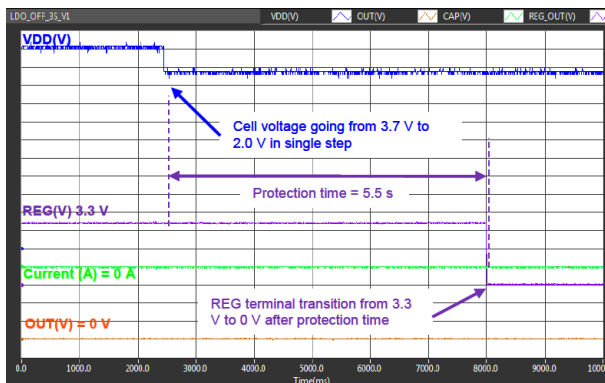

Figure 8-6. Undervoltage Detection to Turn Off the Regulator

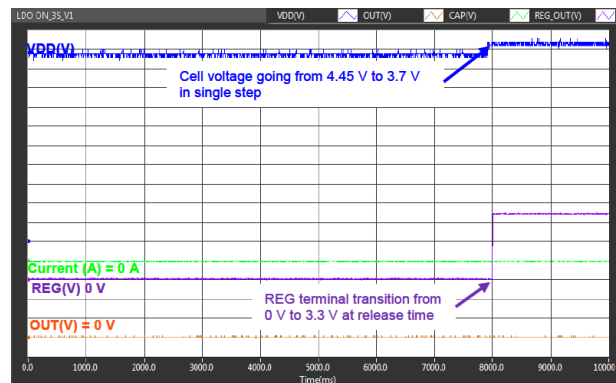

Figure 8-7. Undervoltage Release to Switch On the Regulator

9 Power Supply Recommendations

The maximum power is 20V for BQ2961 and BQ2962 on VDD.

Note

Connect VSS first during power-up.

10 Layout

10.1 Layout Guidelines

Use the following layout guidelines:

1. Ensure the RC filters for the Vx pins and VDD pin are placed as close as possible to the target terminal, reducing the tracing loop area.
2. The capacitor for REG should be placed close to the device terminals.
3. Ensure the trace connecting the fuse to the gate, source of the NFET to the Pack– is sufficient to withstand the current during a fuse blown event.

10.2 Layout Example

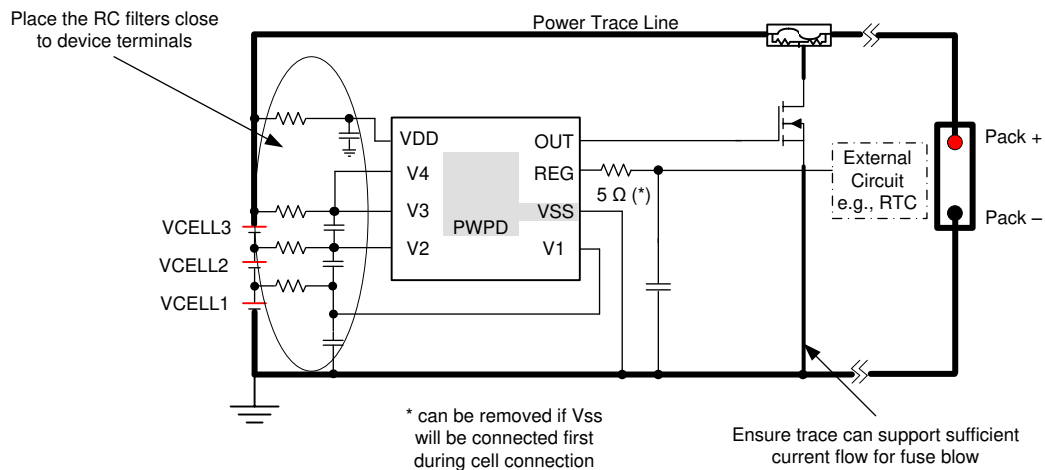

Figure 10-1. Layout Example

11 Device and Documentation Support

11.1 Device Support

11.1.1 Third-Party Products Disclaimer

TI'S PUBLICATION OF INFORMATION REGARDING THIRD-PARTY PRODUCTS OR SERVICES DOES NOT CONSTITUTE AN ENDORSEMENT REGARDING THE SUITABILITY OF SUCH PRODUCTS OR SERVICES OR A WARRANTY, REPRESENTATION OR ENDORSEMENT OF SUCH PRODUCTS OR SERVICES, EITHER ALONE OR IN COMBINATION WITH ANY TI PRODUCT OR SERVICE.

11.2 Receiving Notification of Documentation Updates

To receive notification of documentation updates, navigate to the device product folder on ti.com. In the upper right corner, click on *Alert me* to register and receive a weekly digest of any product information that has changed. For change details, review the revision history included in any revised document.

11.3 Support Resources

[TI E2E™ support forums](#) are an engineer's go-to source for fast, verified answers and design help — straight from the experts. Search existing answers or ask your own question to get the quick design help you need.

Linked content is provided "AS IS" by the respective contributors. They do not constitute TI specifications and do not necessarily reflect TI's views; see TI's [Terms of Use](#).

11.4 Trademarks

TI E2E™ is a trademark of Texas Instruments.

All trademarks are the property of their respective owners.

11.5 Electrostatic Discharge Caution



This integrated circuit can be damaged by ESD. Texas Instruments recommends that all integrated circuits be handled with appropriate precautions. Failure to observe proper handling and installation procedures can cause damage.

ESD damage can range from subtle performance degradation to complete device failure. Precision integrated circuits may be more susceptible to damage because very small parametric changes could cause the device not to meet its published specifications.

11.6 Glossary

[TI Glossary](#) This glossary lists and explains terms, acronyms, and definitions.

12 Revision History

NOTE: Page numbers for previous revisions may differ from page numbers in the current version.

Changes from Revision U (October 2024) to Revision V (September 2025)	Page
• Removed REG_EN pin from table in Pin Configuration and Functions	4
• Removed REG_EN from Absolute Maximum Ratings	5
• Removed REG_EN from Recommended Operating Conditions	5
• Removed REG_EN information from Electrical Characteristics	6
• Removed REG_EN pin from Functional Block Diagram	10
• Changed references of V3 to V4. Corrected figures in Section 7.4.4	12

Changes from Revision T (August 2022) to Revision U (October 2024)	Page
• Added the BQ296235 device to the Device Comparison Table	3

Changes from Revision S (June 2022) to Revision T (August 2022)	Page
• Noted in the Device Comparison Table that the increased UV range is for future BQ2962 devices only.....	3
• Clarified future BQ2962 options.....	9

Changes from Revision R (April 2022) to Revision S (June 2022)	Page
• Increased the UV range for future BQ2962 device in the Device Comparison Table	3

Changes from Revision Q (January 2022) to Revision R (April 2022)	Page
• Changed the BQ296234 device to Production Data in the Device Comparison Table	3

Changes from Revision P (August 2021) to Revision Q (January 2022)	Page
• Added the BQ296234 PRODUCT PREVIEW device to the Device Comparison Table	3

Changes from Revision O (July 2021) to Revision P (August 2021)	Page
• Changed the BQ296227 and BQ296233 devices to Production Data in the Device Comparison Table	3

13 Mechanical, Packaging, and Orderable Information

The following pages include mechanical, packaging, and orderable information. This information is the most current data available for the designated devices. This data is subject to change without notice and revision of this document. For browser-based versions of this data sheet, refer to the left-hand navigation.

PACKAGING INFORMATION

Orderable part number	Status (1)	Material type (2)	Package Pins	Package qty Carrier	RoHS (3)	Lead finish/ Ball material (4)	MSL rating/ Peak reflow (5)	Op temp (°C)	Part marking (6)
BQ296100DSGR	Active	Production	WSON (DSG) 8	3000 LARGE T&R	Yes	NIPDAU	Level-1-260C-UNLIM	-40 to 110	6100
BQ296100DSGR.A	Active	Production	WSON (DSG) 8	3000 LARGE T&R	Yes	NIPDAU	Level-1-260C-UNLIM	-40 to 110	6100
BQ296100DSGT	Active	Production	WSON (DSG) 8	250 SMALL T&R	Yes	NIPDAU	Level-1-260C-UNLIM	-40 to 110	6100
BQ296100DSGT.A	Active	Production	WSON (DSG) 8	250 SMALL T&R	Yes	NIPDAU	Level-1-260C-UNLIM	-40 to 110	6100
BQ296103DSGR	Active	Production	WSON (DSG) 8	3000 LARGE T&R	Yes	NIPDAU SN	Level-1-260C-UNLIM	-40 to 110	6103
BQ296103DSGR.A	Active	Production	WSON (DSG) 8	3000 LARGE T&R	Yes	NIPDAU	Level-1-260C-UNLIM	-40 to 110	6103
BQ296103DSGT	Active	Production	WSON (DSG) 8	250 SMALL T&R	Yes	NIPDAU SN	Level-1-260C-UNLIM	-40 to 110	6103
BQ296103DSGT.A	Active	Production	WSON (DSG) 8	250 SMALL T&R	Yes	NIPDAU	Level-1-260C-UNLIM	-40 to 110	6103
BQ296106DSGR	Active	Production	WSON (DSG) 8	3000 LARGE T&R	Yes	NIPDAU SN	Level-1-260C-UNLIM	-40 to 110	6106
BQ296106DSGR.A	Active	Production	WSON (DSG) 8	3000 LARGE T&R	Yes	NIPDAU	Level-1-260C-UNLIM	-40 to 110	6106
BQ296106DSGT	Active	Production	WSON (DSG) 8	250 SMALL T&R	Yes	NIPDAU SN	Level-1-260C-UNLIM	-40 to 110	6106
BQ296106DSGT.A	Active	Production	WSON (DSG) 8	250 SMALL T&R	Yes	NIPDAU	Level-1-260C-UNLIM	-40 to 110	6106
BQ296107DSGR	Active	Production	WSON (DSG) 8	3000 LARGE T&R	Yes	NIPDAU SN	Level-1-260C-UNLIM	-40 to 110	6107
BQ296107DSGR.A	Active	Production	WSON (DSG) 8	3000 LARGE T&R	Yes	NIPDAU	Level-1-260C-UNLIM	-40 to 110	6107
BQ296107DSGT	Active	Production	WSON (DSG) 8	250 SMALL T&R	Yes	NIPDAU SN	Level-1-260C-UNLIM	-40 to 110	6107
BQ296107DSGT.A	Active	Production	WSON (DSG) 8	250 SMALL T&R	Yes	NIPDAU	Level-1-260C-UNLIM	-40 to 110	6107
BQ296111DSGR	Active	Production	WSON (DSG) 8	3000 LARGE T&R	Yes	NIPDAU	Level-2-260C-1 YEAR	-40 to 110	6111
BQ296111DSGR.A	Active	Production	WSON (DSG) 8	3000 LARGE T&R	Yes	NIPDAU	Level-2-260C-1 YEAR	-40 to 110	6111
BQ296111DSGT	Active	Production	WSON (DSG) 8	250 SMALL T&R	Yes	NIPDAU	Level-1-260C-UNLIM	-40 to 110	6111
BQ296111DSGT.A	Active	Production	WSON (DSG) 8	250 SMALL T&R	Yes	NIPDAU	Level-1-260C-UNLIM	-40 to 110	6111
BQ296112DSGR	Active	Production	WSON (DSG) 8	3000 LARGE T&R	Yes	NIPDAU	Level-2-260C-1 YEAR	-40 to 110	6112
BQ296112DSGR.A	Active	Production	WSON (DSG) 8	3000 LARGE T&R	Yes	NIPDAU	Level-2-260C-1 YEAR	-40 to 110	6112
BQ296112DSGT	Active	Production	WSON (DSG) 8	250 SMALL T&R	Yes	NIPDAU	Level-2-260C-1 YEAR	-40 to 110	6112
BQ296112DSGT.A	Active	Production	WSON (DSG) 8	250 SMALL T&R	Yes	NIPDAU	Level-2-260C-1 YEAR	-40 to 110	6112
BQ296113DSGR	Active	Production	WSON (DSG) 8	3000 LARGE T&R	Yes	NIPDAU	Level-1-260C-UNLIM	-40 to 110	6113
BQ296113DSGR.A	Active	Production	WSON (DSG) 8	3000 LARGE T&R	Yes	NIPDAU	Level-1-260C-UNLIM	-40 to 110	6113
BQ296113DSGT	Active	Production	WSON (DSG) 8	250 SMALL T&R	Yes	NIPDAU	Level-1-260C-UNLIM	-40 to 110	6113
BQ296113DSGT.A	Active	Production	WSON (DSG) 8	250 SMALL T&R	Yes	NIPDAU	Level-1-260C-UNLIM	-40 to 110	6113
BQ296114DSGR	Active	Production	WSON (DSG) 8	3000 LARGE T&R	Yes	NIPDAU	Level-1-260C-UNLIM	-40 to 110	6114

Orderable part number	Status (1)	Material type (2)	Package Pins	Package qty Carrier	RoHS (3)	Lead finish/ Ball material (4)	MSL rating/ Peak reflow (5)	Op temp (°C)	Part marking (6)
BQ296114DSGR.A	Active	Production	WSON (DSG) 8	3000 LARGE T&R	Yes	NIPDAU	Level-1-260C-UNLIM	-40 to 110	6114
BQ296114DSGT	Active	Production	WSON (DSG) 8	250 SMALL T&R	Yes	NIPDAU	Level-1-260C-UNLIM	-40 to 110	6114
BQ296114DSGT.A	Active	Production	WSON (DSG) 8	250 SMALL T&R	Yes	NIPDAU	Level-1-260C-UNLIM	-40 to 110	6114
BQ296115DSGR	Active	Production	WSON (DSG) 8	3000 LARGE T&R	Yes	SN	Level-1-260C-UNLIM	-40 to 110	6115
BQ296115DSGR.A	Active	Production	WSON (DSG) 8	3000 LARGE T&R	Yes	SN	Level-1-260C-UNLIM	-40 to 110	6115
BQ296202DSGR	Active	Production	WSON (DSG) 8	3000 LARGE T&R	Yes	NIPDAU SN	Level-1-260C-UNLIM	-40 to 110	6202
BQ296202DSGR.A	Active	Production	WSON (DSG) 8	3000 LARGE T&R	Yes	NIPDAU	Level-1-260C-UNLIM	-40 to 110	6202
BQ296202DSGT	Active	Production	WSON (DSG) 8	250 SMALL T&R	Yes	NIPDAU SN	Level-1-260C-UNLIM	-40 to 110	6202
BQ296202DSGT.A	Active	Production	WSON (DSG) 8	250 SMALL T&R	Yes	NIPDAU	Level-1-260C-UNLIM	-40 to 110	6202
BQ296203DSGR	Active	Production	WSON (DSG) 8	3000 LARGE T&R	Yes	NIPDAU SN	Level-1-260C-UNLIM	-40 to 110	6203
BQ296203DSGR.A	Active	Production	WSON (DSG) 8	3000 LARGE T&R	Yes	NIPDAU	Level-1-260C-UNLIM	-40 to 110	6203
BQ296203DSGT	Active	Production	WSON (DSG) 8	250 SMALL T&R	Yes	NIPDAU SN	Level-1-260C-UNLIM	-40 to 110	6203
BQ296203DSGT.A	Active	Production	WSON (DSG) 8	250 SMALL T&R	Yes	NIPDAU	Level-1-260C-UNLIM	-40 to 110	6203
BQ296212DSGR	Active	Production	WSON (DSG) 8	3000 LARGE T&R	Yes	NIPDAU	Level-2-260C-1 YEAR	-40 to 110	6212
BQ296212DSGR.A	Active	Production	WSON (DSG) 8	3000 LARGE T&R	Yes	NIPDAU	Level-2-260C-1 YEAR	-40 to 110	6212
BQ296212DSGT	Active	Production	WSON (DSG) 8	250 SMALL T&R	Yes	NIPDAU	Level-2-260C-1 YEAR	-40 to 110	6212
BQ296212DSGT.A	Active	Production	WSON (DSG) 8	250 SMALL T&R	Yes	NIPDAU	Level-2-260C-1 YEAR	-40 to 110	6212
BQ296213DSGR	Active	Production	WSON (DSG) 8	3000 LARGE T&R	Yes	NIPDAU	Level-1-260C-UNLIM	-40 to 110	6213
BQ296213DSGR.A	Active	Production	WSON (DSG) 8	3000 LARGE T&R	Yes	NIPDAU	Level-1-260C-UNLIM	-40 to 110	6213
BQ296213DSGT	Active	Production	WSON (DSG) 8	250 SMALL T&R	Yes	NIPDAU	Level-1-260C-UNLIM	-40 to 110	6213
BQ296213DSGT.A	Active	Production	WSON (DSG) 8	250 SMALL T&R	Yes	NIPDAU	Level-1-260C-UNLIM	-40 to 110	6213
BQ296215DSGR	Active	Production	WSON (DSG) 8	3000 LARGE T&R	Yes	NIPDAU	Level-1-260C-UNLIM	-40 to 110	6215
BQ296215DSGR.A	Active	Production	WSON (DSG) 8	3000 LARGE T&R	Yes	NIPDAU	Level-1-260C-UNLIM	-40 to 110	6215
BQ296215DSGT	Active	Production	WSON (DSG) 8	250 SMALL T&R	Yes	NIPDAU	Level-1-260C-UNLIM	-40 to 110	6215
BQ296215DSGT.A	Active	Production	WSON (DSG) 8	250 SMALL T&R	Yes	NIPDAU	Level-1-260C-UNLIM	-40 to 110	6215
BQ296216DSGR	Active	Production	WSON (DSG) 8	3000 LARGE T&R	Yes	NIPDAU	Level-1-260C-UNLIM	-40 to 110	6216
BQ296216DSGR.A	Active	Production	WSON (DSG) 8	3000 LARGE T&R	Yes	NIPDAU	Level-1-260C-UNLIM	-40 to 110	6216
BQ296216DSGT	Active	Production	WSON (DSG) 8	250 SMALL T&R	Yes	NIPDAU SN	Level-1-260C-UNLIM	-40 to 110	6216
BQ296216DSGT.A	Active	Production	WSON (DSG) 8	250 SMALL T&R	Yes	NIPDAU	Level-1-260C-UNLIM	-40 to 110	6216
BQ296217DSGR	Active	Production	WSON (DSG) 8	3000 LARGE T&R	Yes	NIPDAU SN	Level-1-260C-UNLIM	-40 to 110	6217
BQ296217DSGR.A	Active	Production	WSON (DSG) 8	3000 LARGE T&R	Yes	NIPDAU	Level-1-260C-UNLIM	-40 to 110	6217

Orderable part number	Status (1)	Material type (2)	Package Pins	Package qty Carrier	RoHS (3)	Lead finish/ Ball material (4)	MSL rating/ Peak reflow (5)	Op temp (°C)	Part marking (6)
BQ296217DSGT	Active	Production	WSON (DSG) 8	250 SMALL T&R	Yes	NIPDAU SN	Level-1-260C-UNLIM	-40 to 110	6217
BQ296217DSGT.A	Active	Production	WSON (DSG) 8	250 SMALL T&R	Yes	NIPDAU	Level-1-260C-UNLIM	-40 to 110	6217
BQ296221DSGR	Active	Production	WSON (DSG) 8	3000 LARGE T&R	Yes	SN	Level-2-260C-1 YEAR	-40 to 110	6221
BQ296221DSGR.A	Active	Production	WSON (DSG) 8	3000 LARGE T&R	Yes	SN	Level-2-260C-1 YEAR	-40 to 110	6221
BQ296221DSGT	Active	Production	WSON (DSG) 8	250 SMALL T&R	Yes	NIPDAU	Level-1-260C-UNLIM	-40 to 110	6221
BQ296221DSGT.A	Active	Production	WSON (DSG) 8	250 SMALL T&R	Yes	NIPDAU	Level-1-260C-UNLIM	-40 to 110	6221
BQ296222DSGR	Active	Production	WSON (DSG) 8	3000 LARGE T&R	Yes	NIPDAU	Level-1-260C-UNLIM	-40 to 110	6222
BQ296222DSGR.A	Active	Production	WSON (DSG) 8	3000 LARGE T&R	Yes	NIPDAU	Level-1-260C-UNLIM	-40 to 110	6222
BQ296222DSGT	Active	Production	WSON (DSG) 8	250 SMALL T&R	Yes	SN	Level-1-260C-UNLIM	-40 to 110	6222
BQ296222DSGT.A	Active	Production	WSON (DSG) 8	250 SMALL T&R	Yes	SN	Level-1-260C-UNLIM	-40 to 110	6222
BQ296223DSGR	Active	Production	WSON (DSG) 8	3000 LARGE T&R	Yes	NIPDAU	Level-1-260C-UNLIM	-40 to 110	6223
BQ296223DSGR.A	Active	Production	WSON (DSG) 8	3000 LARGE T&R	Yes	NIPDAU	Level-1-260C-UNLIM	-40 to 110	6223
BQ296223DSGT	Active	Production	WSON (DSG) 8	250 SMALL T&R	Yes	NIPDAU	Level-1-260C-UNLIM	-40 to 110	6223
BQ296223DSGT.A	Active	Production	WSON (DSG) 8	250 SMALL T&R	Yes	NIPDAU	Level-1-260C-UNLIM	-40 to 110	6223
BQ296224DSGR	Active	Production	WSON (DSG) 8	3000 LARGE T&R	Yes	NIPDAU	Level-1-260C-UNLIM	-40 to 110	6224
BQ296224DSGR.A	Active	Production	WSON (DSG) 8	3000 LARGE T&R	Yes	NIPDAU	Level-1-260C-UNLIM	-40 to 110	6224
BQ296224DSGT	Active	Production	WSON (DSG) 8	250 SMALL T&R	Yes	NIPDAU	Level-1-260C-UNLIM	-40 to 110	6224
BQ296224DSGT.A	Active	Production	WSON (DSG) 8	250 SMALL T&R	Yes	NIPDAU	Level-1-260C-UNLIM	-40 to 110	6224
BQ296226DSGR	Active	Production	WSON (DSG) 8	3000 LARGE T&R	Yes	NIPDAU	Level-1-260C-UNLIM	-40 to 110	6226
BQ296226DSGR.A	Active	Production	WSON (DSG) 8	3000 LARGE T&R	Yes	NIPDAU	Level-1-260C-UNLIM	-40 to 110	6226
BQ296226DSGT	Active	Production	WSON (DSG) 8	250 SMALL T&R	Yes	NIPDAU	Level-1-260C-UNLIM	-40 to 110	6226
BQ296226DSGT.A	Active	Production	WSON (DSG) 8	250 SMALL T&R	Yes	NIPDAU	Level-1-260C-UNLIM	-40 to 110	6226
BQ296227DSGR	Active	Production	WSON (DSG) 8	3000 LARGE T&R	Yes	SN	Level-1-260C-UNLIM	-40 to 110	6227
BQ296227DSGR.A	Active	Production	WSON (DSG) 8	3000 LARGE T&R	Yes	SN	Level-1-260C-UNLIM	-40 to 110	6227
BQ296228DSGR	Active	Production	WSON (DSG) 8	3000 LARGE T&R	Yes	NIPDAU	Level-1-260C-UNLIM	-40 to 110	6228
BQ296228DSGR.A	Active	Production	WSON (DSG) 8	3000 LARGE T&R	Yes	NIPDAU	Level-1-260C-UNLIM	-40 to 110	6228
BQ296228DSGT	Active	Production	WSON (DSG) 8	250 SMALL T&R	Yes	NIPDAU	Level-1-260C-UNLIM	-40 to 110	6228
BQ296228DSGT.A	Active	Production	WSON (DSG) 8	250 SMALL T&R	Yes	NIPDAU	Level-1-260C-UNLIM	-40 to 110	6228
BQ296229DSGR	Active	Production	WSON (DSG) 8	3000 LARGE T&R	Yes	NIPDAU	Level-1-260C-UNLIM	-40 to 110	6229
BQ296229DSGR.A	Active	Production	WSON (DSG) 8	3000 LARGE T&R	Yes	NIPDAU	Level-1-260C-UNLIM	-40 to 110	6229
BQ296229DSGT	Active	Production	WSON (DSG) 8	250 SMALL T&R	Yes	NIPDAU	Level-1-260C-UNLIM	-40 to 110	6229

Orderable part number	Status (1)	Material type (2)	Package Pins	Package qty Carrier	RoHS (3)	Lead finish/ Ball material (4)	MSL rating/ Peak reflow (5)	Op temp (°C)	Part marking (6)
BQ296229DSGT.A	Active	Production	WSON (DSG) 8	250 SMALL T&R	Yes	NIPDAU	Level-1-260C-UNLIM	-40 to 110	6229
BQ296230DSGR	Active	Production	WSON (DSG) 8	3000 LARGE T&R	Yes	NIPDAU	Level-1-260C-UNLIM	-40 to 110	6230
BQ296230DSGR.A	Active	Production	WSON (DSG) 8	3000 LARGE T&R	Yes	NIPDAU	Level-1-260C-UNLIM	-40 to 110	6230
BQ296230DSGT	Active	Production	WSON (DSG) 8	250 SMALL T&R	Yes	NIPDAU	Level-1-260C-UNLIM	-40 to 110	6230
BQ296230DSGT.A	Active	Production	WSON (DSG) 8	250 SMALL T&R	Yes	NIPDAU	Level-1-260C-UNLIM	-40 to 110	6230
BQ296231DSGR	Active	Production	WSON (DSG) 8	3000 LARGE T&R	Yes	NIPDAU	Level-1-260C-UNLIM	-40 to 110	6231
BQ296231DSGR.A	Active	Production	WSON (DSG) 8	3000 LARGE T&R	Yes	NIPDAU	Level-1-260C-UNLIM	-40 to 110	6231
BQ296231DSGT	Active	Production	WSON (DSG) 8	250 SMALL T&R	Yes	NIPDAU	Level-1-260C-UNLIM	-40 to 110	6231
BQ296231DSGT.A	Active	Production	WSON (DSG) 8	250 SMALL T&R	Yes	NIPDAU	Level-1-260C-UNLIM	-40 to 110	6231
BQ296232DSGR	Active	Production	WSON (DSG) 8	3000 LARGE T&R	Yes	NIPDAU	Level-1-260C-UNLIM	-40 to 110	6232
BQ296232DSGR.A	Active	Production	WSON (DSG) 8	3000 LARGE T&R	Yes	NIPDAU	Level-1-260C-UNLIM	-40 to 110	6232
BQ296232DSGT	Active	Production	WSON (DSG) 8	250 SMALL T&R	Yes	NIPDAU	Level-1-260C-UNLIM	-40 to 110	6232
BQ296232DSGT.A	Active	Production	WSON (DSG) 8	250 SMALL T&R	Yes	NIPDAU	Level-1-260C-UNLIM	-40 to 110	6232
BQ296233DSGR	Active	Production	WSON (DSG) 8	3000 LARGE T&R	Yes	SN	Level-1-260C-UNLIM	-40 to 110	6233
BQ296233DSGR.A	Active	Production	WSON (DSG) 8	3000 LARGE T&R	Yes	SN	Level-1-260C-UNLIM	-40 to 110	6233
BQ296234DSGR	Active	Production	WSON (DSG) 8	3000 LARGE T&R	Yes	NIPDAU	Level-1-260C-UNLIM	-40 to 110	6234
BQ296234DSGR.A	Active	Production	WSON (DSG) 8	3000 LARGE T&R	Yes	NIPDAU	Level-1-260C-UNLIM	-40 to 110	6234
BQ296235DSGR	Active	Production	WSON (DSG) 8	3000 LARGE T&R	Yes	NIPDAU	Level-1-260C-UNLIM	-40 to 110	6235
BQ296235DSGR.A	Active	Production	WSON (DSG) 8	3000 LARGE T&R	Yes	NIPDAU	Level-1-260C-UNLIM	-40 to 110	6235

(1) **Status:** For more details on status, see our [product life cycle](#).

(2) **Material type:** When designated, preproduction parts are prototypes/experimental devices, and are not yet approved or released for full production. Testing and final process, including without limitation quality assurance, reliability performance testing, and/or process qualification, may not yet be complete, and this item is subject to further changes or possible discontinuation. If available for ordering, purchases will be subject to an additional waiver at checkout, and are intended for early internal evaluation purposes only. These items are sold without warranties of any kind.

(3) **RoHS values:** Yes, No, RoHS Exempt. See the [TI RoHS Statement](#) for additional information and value definition.

(4) **Lead finish/Ball material:** Parts may have multiple material finish options. Finish options are separated by a vertical ruled line. Lead finish/Ball material values may wrap to two lines if the finish value exceeds the maximum column width.

(5) **MSL rating/Peak reflow:** The moisture sensitivity level ratings and peak solder (reflow) temperatures. In the event that a part has multiple moisture sensitivity ratings, only the lowest level per JEDEC standards is shown. Refer to the shipping label for the actual reflow temperature that will be used to mount the part to the printed circuit board.

(6) **Part marking:** There may be an additional marking, which relates to the logo, the lot trace code information, or the environmental category of the part.

Multiple part markings will be inside parentheses. Only one part marking contained in parentheses and separated by a "~" will appear on a part. If a line is indented then it is a continuation of the previous line and the two combined represent the entire part marking for that device.

Important Information and Disclaimer:The information provided on this page represents TI's knowledge and belief as of the date that it is provided. TI bases its knowledge and belief on information provided by third parties, and makes no representation or warranty as to the accuracy of such information. Efforts are underway to better integrate information from third parties. TI has taken and continues to take reasonable steps to provide representative and accurate information but may not have conducted destructive testing or chemical analysis on incoming materials and chemicals. TI and TI suppliers consider certain information to be proprietary, and thus CAS numbers and other limited information may not be available for release.

In no event shall TI's liability arising out of such information exceed the total purchase price of the TI part(s) at issue in this document sold by TI to Customer on an annual basis.

TAPE AND REEL INFORMATION



QUADRANT ASSIGNMENTS FOR PIN 1 ORIENTATION IN TAPE



*All dimensions are nominal

Device	Package Type	Package Drawing	Pins	SPQ	Reel Diameter (mm)	Reel Width W1 (mm)	A0 (mm)	B0 (mm)	K0 (mm)	P1 (mm)	W (mm)	Pin1 Quadrant
BQ296100DSGR	WSON	DSG	8	3000	180.0	8.4	2.3	2.3	1.15	4.0	8.0	Q2
BQ296100DSGT	WSON	DSG	8	250	180.0	8.4	2.3	2.3	1.15	4.0	8.0	Q2
BQ296103DSGR	WSON	DSG	8	3000	180.0	8.4	2.3	2.3	1.15	4.0	8.0	Q2
BQ296103DSGT	WSON	DSG	8	250	180.0	8.4	2.3	2.3	1.15	4.0	8.0	Q2
BQ296106DSGR	WSON	DSG	8	3000	180.0	8.4	2.3	2.3	1.15	4.0	8.0	Q2
BQ296106DSGT	WSON	DSG	8	250	180.0	8.4	2.3	2.3	1.15	4.0	8.0	Q2
BQ296107DSGR	WSON	DSG	8	3000	180.0	8.4	2.3	2.3	1.15	4.0	8.0	Q2
BQ296107DSGT	WSON	DSG	8	250	180.0	8.4	2.3	2.3	1.15	4.0	8.0	Q2
BQ296111DSGR	WSON	DSG	8	3000	180.0	8.4	2.3	2.3	1.15	4.0	8.0	Q2
BQ296111DSGT	WSON	DSG	8	250	180.0	8.4	2.3	2.3	1.15	4.0	8.0	Q2
BQ296112DSGR	WSON	DSG	8	3000	180.0	8.4	2.3	2.3	1.15	4.0	8.0	Q2
BQ296112DSGT	WSON	DSG	8	250	180.0	8.4	2.3	2.3	1.15	4.0	8.0	Q2
BQ296113DSGR	WSON	DSG	8	3000	180.0	8.4	2.3	2.3	1.15	4.0	8.0	Q2
BQ296113DSGT	WSON	DSG	8	250	180.0	8.4	2.3	2.3	1.15	4.0	8.0	Q2
BQ296114DSGR	WSON	DSG	8	3000	180.0	8.4	2.3	2.3	1.15	4.0	8.0	Q2
BQ296114DSGT	WSON	DSG	8	250	180.0	8.4	2.3	2.3	1.15	4.0	8.0	Q2

Device	Package Type	Package Drawing	Pins	SPQ	Reel Diameter (mm)	Reel Width W1 (mm)	A0 (mm)	B0 (mm)	K0 (mm)	P1 (mm)	W (mm)	Pin1 Quadrant
BQ296115DSGR	WSON	DSG	8	3000	180.0	8.4	2.3	2.3	1.15	4.0	8.0	Q2
BQ296202DSGR	WSON	DSG	8	3000	180.0	8.4	2.3	2.3	1.15	4.0	8.0	Q2
BQ296202DSGT	WSON	DSG	8	250	180.0	8.4	2.3	2.3	1.15	4.0	8.0	Q2
BQ296203DSGR	WSON	DSG	8	3000	180.0	8.4	2.3	2.3	1.15	4.0	8.0	Q2
BQ296203DSGT	WSON	DSG	8	250	180.0	8.4	2.3	2.3	1.15	4.0	8.0	Q2
BQ296212DSGR	WSON	DSG	8	3000	180.0	8.4	2.3	2.3	1.15	4.0	8.0	Q2
BQ296212DSGT	WSON	DSG	8	250	180.0	8.4	2.3	2.3	1.15	4.0	8.0	Q2
BQ296213DSGR	WSON	DSG	8	3000	180.0	8.4	2.3	2.3	1.15	4.0	8.0	Q2
BQ296213DSGT	WSON	DSG	8	250	180.0	8.4	2.3	2.3	1.15	4.0	8.0	Q2
BQ296215DSGR	WSON	DSG	8	3000	180.0	8.4	2.3	2.3	1.15	4.0	8.0	Q2
BQ296215DSGT	WSON	DSG	8	250	180.0	8.4	2.3	2.3	1.15	4.0	8.0	Q2
BQ296216DSGR	WSON	DSG	8	3000	180.0	8.4	2.3	2.3	1.15	4.0	8.0	Q2
BQ296216DSGT	WSON	DSG	8	250	180.0	8.4	2.3	2.3	1.15	4.0	8.0	Q2
BQ296217DSGR	WSON	DSG	8	3000	180.0	8.4	2.3	2.3	1.15	4.0	8.0	Q2
BQ296217DSGT	WSON	DSG	8	250	180.0	8.4	2.3	2.3	1.15	4.0	8.0	Q2
BQ296221DSGR	WSON	DSG	8	3000	180.0	8.4	2.3	2.3	1.15	4.0	8.0	Q3
BQ296221DSGT	WSON	DSG	8	250	180.0	8.4	2.3	2.3	1.15	4.0	8.0	Q3
BQ296222DSGR	WSON	DSG	8	3000	180.0	8.4	2.3	2.3	1.15	4.0	8.0	Q3
BQ296222DSGT	WSON	DSG	8	250	180.0	8.4	2.3	2.3	1.15	4.0	8.0	Q3
BQ296223DSGR	WSON	DSG	8	3000	180.0	8.4	2.3	2.3	1.15	4.0	8.0	Q3
BQ296223DSGT	WSON	DSG	8	250	180.0	8.4	2.3	2.3	1.15	4.0	8.0	Q3
BQ296224DSGR	WSON	DSG	8	3000	180.0	8.4	2.3	2.3	1.15	4.0	8.0	Q3
BQ296224DSGT	WSON	DSG	8	250	180.0	8.4	2.3	2.3	1.15	4.0	8.0	Q3
BQ296226DSGR	WSON	DSG	8	3000	180.0	8.4	2.3	2.3	1.15	4.0	8.0	Q3
BQ296226DSGT	WSON	DSG	8	250	180.0	8.4	2.3	2.3	1.15	4.0	8.0	Q3
BQ296227DSGR	WSON	DSG	8	3000	180.0	8.4	2.3	2.3	1.15	4.0	8.0	Q3
BQ296228DSGR	WSON	DSG	8	3000	180.0	8.4	2.3	2.3	1.15	4.0	8.0	Q3
BQ296228DSGT	WSON	DSG	8	250	180.0	8.4	2.3	2.3	1.15	4.0	8.0	Q3
BQ296229DSGR	WSON	DSG	8	3000	180.0	8.4	2.3	2.3	1.15	4.0	8.0	Q3
BQ296229DSGT	WSON	DSG	8	250	180.0	8.4	2.3	2.3	1.15	4.0	8.0	Q3
BQ296230DSGR	WSON	DSG	8	3000	180.0	8.4	2.3	2.3	1.15	4.0	8.0	Q3
BQ296230DSGT	WSON	DSG	8	250	180.0	8.4	2.3	2.3	1.15	4.0	8.0	Q3
BQ296231DSGR	WSON	DSG	8	3000	180.0	8.4	2.3	2.3	1.15	4.0	8.0	Q3
BQ296231DSGT	WSON	DSG	8	250	180.0	8.4	2.3	2.3	1.15	4.0	8.0	Q3
BQ296232DSGR	WSON	DSG	8	3000	180.0	8.4	2.3	2.3	1.15	4.0	8.0	Q3
BQ296232DSGT	WSON	DSG	8	250	180.0	8.4	2.3	2.3	1.15	4.0	8.0	Q3
BQ296233DSGR	WSON	DSG	8	3000	180.0	8.4	2.3	2.3	1.15	4.0	8.0	Q3
BQ296234DSGR	WSON	DSG	8	3000	180.0	8.4	2.3	2.3	1.15	4.0	8.0	Q3
BQ296235DSGR	WSON	DSG	8	3000	180.0	8.4	2.3	2.3	1.15	4.0	8.0	Q3

TAPE AND REEL BOX DIMENSIONS



*All dimensions are nominal

Device	Package Type	Package Drawing	Pins	SPQ	Length (mm)	Width (mm)	Height (mm)
BQ296100DSGR	WSON	DSG	8	3000	182.0	182.0	20.0
BQ296100DSGT	WSON	DSG	8	250	182.0	182.0	20.0
BQ296103DSGR	WSON	DSG	8	3000	182.0	182.0	20.0
BQ296103DSGT	WSON	DSG	8	250	182.0	182.0	20.0
BQ296106DSGR	WSON	DSG	8	3000	182.0	182.0	20.0
BQ296106DSGT	WSON	DSG	8	250	182.0	182.0	20.0
BQ296107DSGR	WSON	DSG	8	3000	182.0	182.0	20.0
BQ296107DSGT	WSON	DSG	8	250	182.0	182.0	20.0
BQ296111DSGR	WSON	DSG	8	3000	210.0	185.0	35.0
BQ296111DSGT	WSON	DSG	8	250	182.0	182.0	20.0
BQ296112DSGR	WSON	DSG	8	3000	210.0	185.0	35.0
BQ296112DSGT	WSON	DSG	8	250	210.0	185.0	35.0
BQ296113DSGR	WSON	DSG	8	3000	182.0	182.0	20.0
BQ296113DSGT	WSON	DSG	8	250	182.0	182.0	20.0
BQ296114DSGR	WSON	DSG	8	3000	182.0	182.0	20.0
BQ296114DSGT	WSON	DSG	8	250	182.0	182.0	20.0
BQ296115DSGR	WSON	DSG	8	3000	210.0	185.0	35.0
BQ296202DSGR	WSON	DSG	8	3000	182.0	182.0	20.0

Device	Package Type	Package Drawing	Pins	SPQ	Length (mm)	Width (mm)	Height (mm)
BQ296202DSGT	WSON	DSG	8	250	182.0	182.0	20.0
BQ296203DSGR	WSON	DSG	8	3000	182.0	182.0	20.0
BQ296203DSGT	WSON	DSG	8	250	182.0	182.0	20.0
BQ296212DSGR	WSON	DSG	8	3000	210.0	185.0	35.0
BQ296212DSGT	WSON	DSG	8	250	210.0	185.0	35.0
BQ296213DSGR	WSON	DSG	8	3000	182.0	182.0	20.0
BQ296213DSGT	WSON	DSG	8	250	182.0	182.0	20.0
BQ296215DSGR	WSON	DSG	8	3000	210.0	185.0	35.0
BQ296215DSGT	WSON	DSG	8	250	210.0	185.0	35.0
BQ296216DSGR	WSON	DSG	8	3000	182.0	182.0	20.0
BQ296216DSGT	WSON	DSG	8	250	182.0	182.0	20.0
BQ296217DSGR	WSON	DSG	8	3000	182.0	182.0	20.0
BQ296217DSGT	WSON	DSG	8	250	182.0	182.0	20.0
BQ296221DSGR	WSON	DSG	8	3000	210.0	185.0	35.0
BQ296221DSGT	WSON	DSG	8	250	210.0	185.0	35.0
BQ296222DSGR	WSON	DSG	8	3000	210.0	185.0	35.0
BQ296222DSGT	WSON	DSG	8	250	210.0	185.0	35.0
BQ296223DSGR	WSON	DSG	8	3000	210.0	185.0	35.0
BQ296223DSGT	WSON	DSG	8	250	210.0	185.0	35.0
BQ296224DSGR	WSON	DSG	8	3000	210.0	185.0	35.0
BQ296224DSGT	WSON	DSG	8	250	210.0	185.0	35.0
BQ296226DSGR	WSON	DSG	8	3000	210.0	185.0	35.0
BQ296226DSGT	WSON	DSG	8	250	210.0	185.0	35.0
BQ296227DSGR	WSON	DSG	8	3000	210.0	185.0	35.0
BQ296228DSGR	WSON	DSG	8	3000	210.0	185.0	35.0
BQ296228DSGT	WSON	DSG	8	250	210.0	185.0	35.0
BQ296229DSGR	WSON	DSG	8	3000	210.0	185.0	35.0
BQ296229DSGT	WSON	DSG	8	250	210.0	185.0	35.0
BQ296230DSGR	WSON	DSG	8	3000	210.0	185.0	35.0
BQ296230DSGT	WSON	DSG	8	250	210.0	185.0	35.0
BQ296231DSGR	WSON	DSG	8	3000	210.0	185.0	35.0
BQ296231DSGT	WSON	DSG	8	250	210.0	185.0	35.0
BQ296232DSGR	WSON	DSG	8	3000	210.0	185.0	35.0
BQ296232DSGT	WSON	DSG	8	250	210.0	185.0	35.0
BQ296233DSGR	WSON	DSG	8	3000	210.0	185.0	35.0
BQ296234DSGR	WSON	DSG	8	3000	210.0	185.0	35.0
BQ296235DSGR	WSON	DSG	8	3000	210.0	185.0	35.0

GENERIC PACKAGE VIEW

DSG 8

WSON - 0.8 mm max height

2 x 2, 0.5 mm pitch

PLASTIC SMALL OUTLINE - NO LEAD

This image is a representation of the package family, actual package may vary.
Refer to the product data sheet for package details.

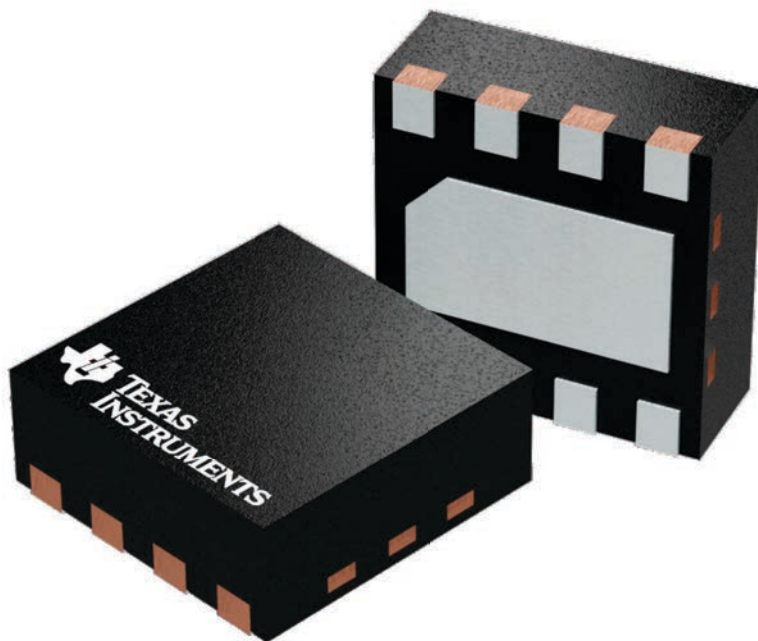

4224783/A

DSG0008A

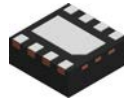

PACKAGE OUTLINE

WSON - 0.8 mm max height

PLASTIC SMALL OUTLINE - NO LEAD

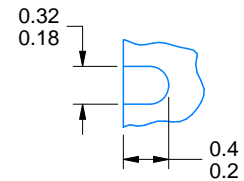
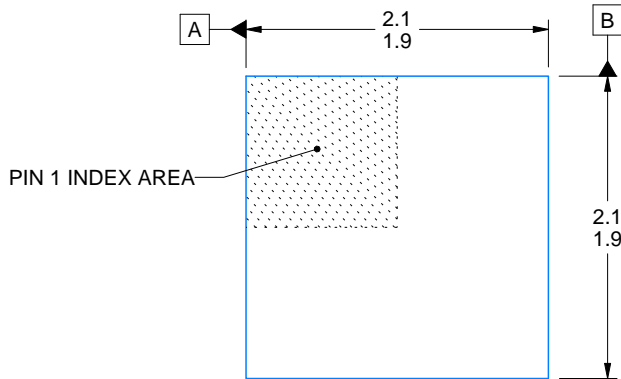

ALTERNATIVE TERMINAL SHAPE TYPICAL

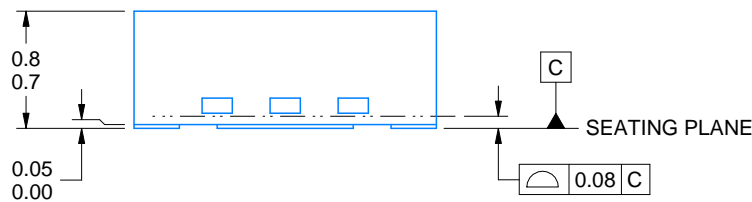

SIDE WALL METAL THICKNESS DIM A	
OPTION 1	OPTION 2
0.1	0.2

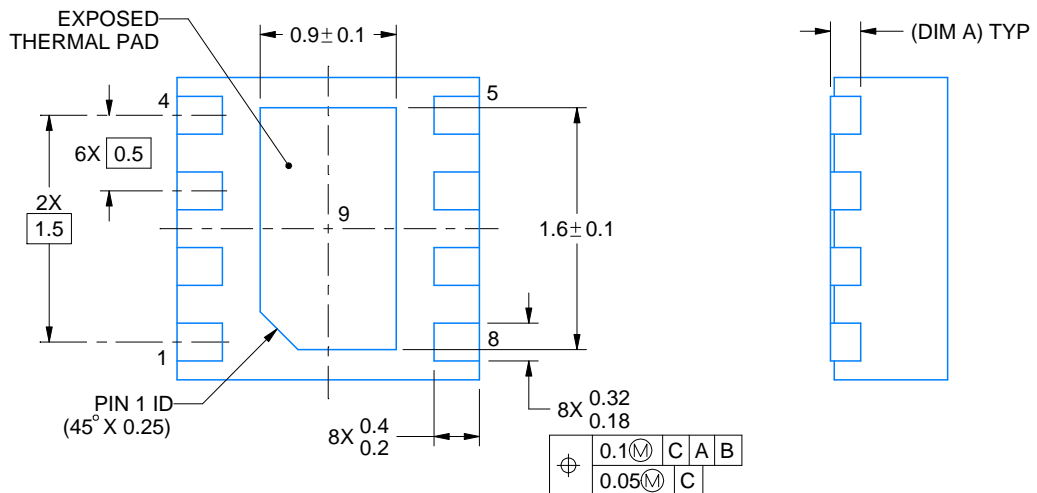

4218900/E 08/2022

NOTES:

1. All linear dimensions are in millimeters. Any dimensions in parenthesis are for reference only. Dimensioning and tolerancing per ASME Y14.5M.
2. This drawing is subject to change without notice.
3. The package thermal pad must be soldered to the printed circuit board for thermal and mechanical performance.

IMPORTANT NOTICE AND DISCLAIMER

TI PROVIDES TECHNICAL AND RELIABILITY DATA (INCLUDING DATASHEETS), DESIGN RESOURCES (INCLUDING REFERENCE DESIGNS), APPLICATION OR OTHER DESIGN ADVICE, WEB TOOLS, SAFETY INFORMATION, AND OTHER RESOURCES "AS IS" AND WITH ALL FAULTS, AND DISCLAIMS ALL WARRANTIES, EXPRESS AND IMPLIED, INCLUDING WITHOUT LIMITATION ANY IMPLIED WARRANTIES OF MERCHANTABILITY, FITNESS FOR A PARTICULAR PURPOSE OR NON-INFRINGEMENT OF THIRD PARTY INTELLECTUAL PROPERTY RIGHTS.

These resources are intended for skilled developers designing with TI products. You are solely responsible for (1) selecting the appropriate TI products for your application, (2) designing, validating and testing your application, and (3) ensuring your application meets applicable standards, and any other safety, security, regulatory or other requirements.

These resources are subject to change without notice. TI grants you permission to use these resources only for development of an application that uses the TI products described in the resource. Other reproduction and display of these resources is prohibited. No license is granted to any other TI intellectual property right or to any third party intellectual property right. TI disclaims responsibility for, and you fully indemnify TI and its representatives against any claims, damages, costs, losses, and liabilities arising out of your use of these resources.

TI's products are provided subject to [TI's Terms of Sale](#), [TI's General Quality Guidelines](#), or other applicable terms available either on ti.com or provided in conjunction with such TI products. TI's provision of these resources does not expand or otherwise alter TI's applicable warranties or warranty disclaimers for TI products. Unless TI explicitly designates a product as custom or customer-specified, TI products are standard, catalog, general purpose devices.

TI objects to and rejects any additional or different terms you may propose.

Copyright © 2026, Texas Instruments Incorporated

Last updated 10/2025

Looking for pricing, stock, or lifecycle information?

Click below to explore more details on WIN SOURCE:

 [View BQ296112DSGR on WIN SOURCE](#)

 [Texas Instruments](#) Information

Optimize Your Supply Chain with WIN SOURCE Solutions

-  Global Sourcing Solution
-  Obsolete Management
-  Cost Control Management
-  Shortage Management
-  Alternative Solution
-  Excess Inventory Management