

ESP32-C5

esp-dev-kits Documentation



Release master
Espressif Systems
May 19, 2026

Table of contents

Table of contents	i
1 ESP32-C5-DevKitC-1	3
1.1 ESP32-C5-DevKitC-1 v1.2	3
1.1.1 Getting Started	3
1.1.2 Hardware Reference	6
1.1.3 Hardware Revision Details	7
1.1.4 Related Documents	8
2 ESP-SensairShuttle	15
2.1 ESP-SensairShuttle v1.0	15
2.1.1 Getting Started	16
2.1.2 Hardware Reference	21
2.1.3 Hardware Revision History	24
2.1.4 Related Documents	24
3 Related Documentation and Resources	27
3.1 Developer Zone	27
3.2 Products	27
3.3 Contact Us	27
4 Disclaimer and Copyright Notice	29

This document provides detailed user guides and examples for ESP32-C5 series development boards.

Note: For the full list of Espressif development boards, please go to [ESP DevKits](#).

Chapter 1

ESP32-C5-DevKitC-1

ESP32-C5-DevKitC-1 is an entry-level development board based on the general-purpose module ESP32-C5-WROOM-1(U). This board integrates complete Wi-Fi, Bluetooth LE, Zigbee, and Thread functions.

1.1 ESP32-C5-DevKitC-1 v1.2

Older version: [ESP32-C5-DevKitC-1 v1.1](#)

This user guide will help you get started with ESP32-C5-DevKitC-1 and will also provide more in-depth information.

The ESP32-C5-DevKitC-1 is an entry-level development board based on the general-purpose module [ESP32-C5-WROOM-1\(U\)](#). This board integrates complete Wi-Fi, Bluetooth (LE), Zigbee, and Thread functions.

Most of the I/O pins are broken out to the pin headers on both sides for easy interfacing. Developers can either connect peripherals with jumper wires or mount ESP32-C5-DevKitC-1 on a breadboard.

The document consists of the following major sections:

- [Getting Started](#): Overview of ESP32-C5-DevKitC-1 and hardware/software setup instructions to get started.
- [Hardware Reference](#): More detailed information about the ESP32-C5-DevKitC-1's hardware.
- [Hardware Revision Details](#): Information about revision history, known issues, and links to user guides for previous versions (if any).
- [Related Documents](#): Links to related documentation.

1.1.1 Getting Started

This section provides a brief introduction to ESP32-C5-DevKitC-1, introducing how to perform the initial hardware setup and how to flash firmware onto the board.

Description of Components

The following list provides a description of the key components on the board in a clockwise direction.

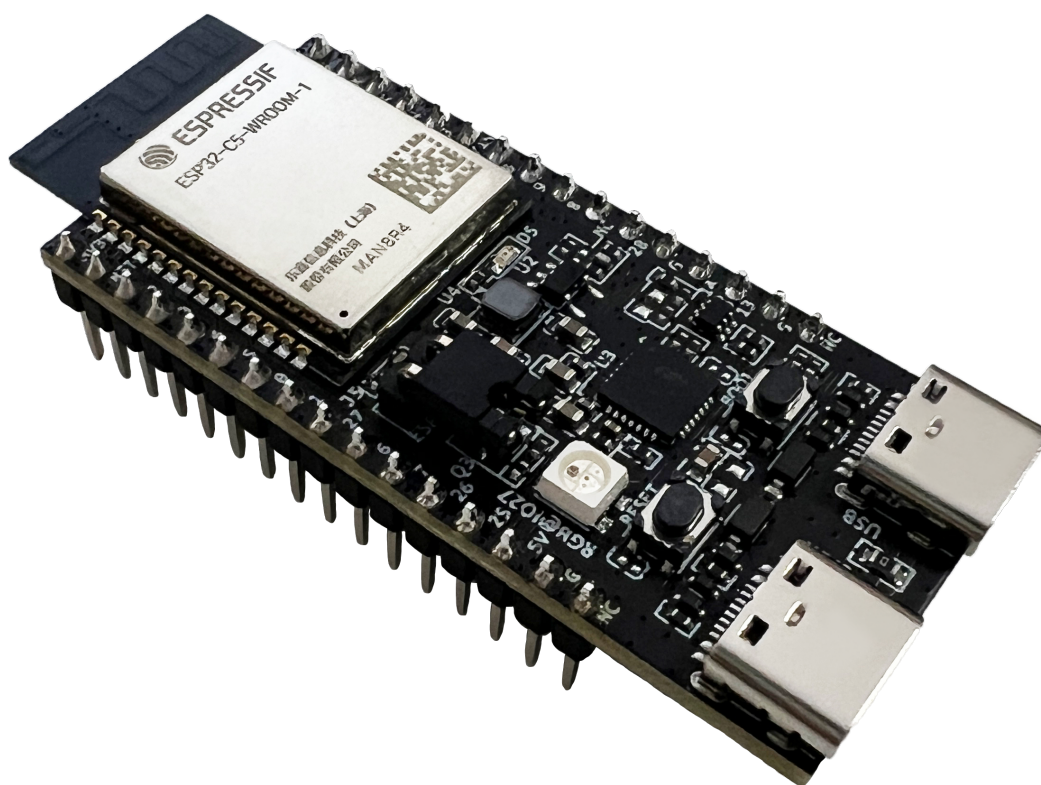

Fig. 1: ESP32-C5-DevKitC-1

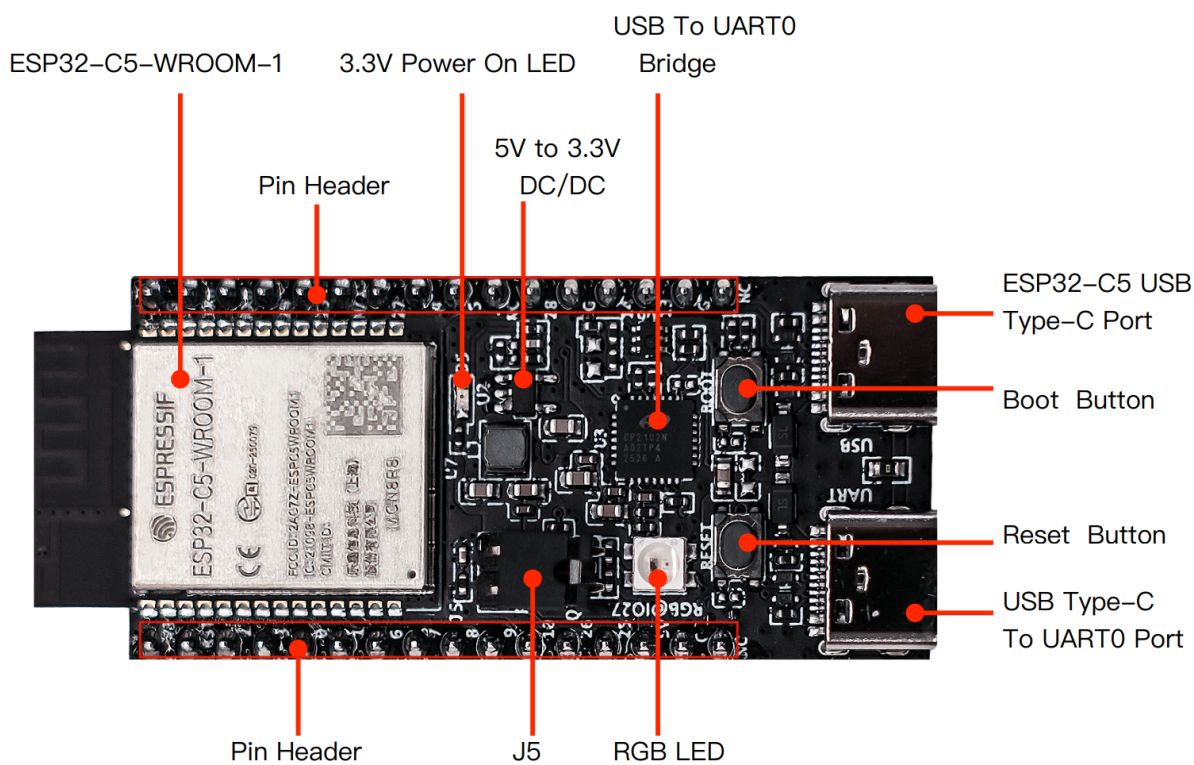

Fig. 2: ESP32-C5-DevKitC-1 - front

Key Component	Description
ESP32-C5-WROOM-1(U)	ESP32-C5-WROOM-1(U) is a general-purpose module supporting Wi-Fi 6 in 2.4 & 5 GHz dual-band (802.11ax), Bluetooth® 5 (LE), Zigbee, and Thread (802.15.4) with on-board PCB antenna.
Pin Header	All available GPIO pins (except for the SPI bus for flash) are broken out to the pin headers on the board.
5 V to 3.3 V DC/DC	Power regulator that converts a 5 V supply into a 3.3 V output.
3.3 V Power On LED	Turns on when the the board is connected to USB power.
USB-to-UART Bridge	Single-chip USB-to-UART bridge offering transfer rate up to 3 Mbps.
ESP32-C5 USB Type-C Port	The USB Type-C port on the ESP32-C5 chip supports USB 2.0 full speed, with a data transfer rate of up to 12 Mbps. Note that this port does not support the 480 Mbps high-speed transfer mode. This port is used for power supply to the board, flashing applications to the chip, and communication with the chip via USB protocols, as well as for JTAG debugging.
Boot Button	Download button. Holding down Boot and then pressing Reset initiates Firmware Download mode for downloading firmware through the serial port.
Reset Button	Press this button to restart the system.
USB Type-C to UART Port	Used for power supply to the board, flashing applications to the chip, as well as communication with chip ESP32-C5 via the on-board USB-to-UART bridge.
RGB LED	Addressable RGB LED, driven by GPIO27.
J5	Used for current measurement. See details in Section Current Measurement .

Start Application Development

Before powering up your ESP32-C5-DevKitC-1, please make sure that it is in good condition with no obvious sign of damage.

Required Hardware

- ESP32-C5-DevKitC-1
- USB-A to USB-C cable
- Computer running Windows, Linux, or macOS

Note: Be sure to use a good quality USB cable. Some cables are for charging only and do not provide the needed data lines nor work for programming the boards.

Software Setup Please proceed to [ESP-IDF Get Started](#), which will help you set up the development environment quickly and then flash an application example onto your board.

Contents and Packaging

Retail orders If you order a few samples, each ESP32-C5-DevKitC-1 comes in an individual package in either an antistatic bag or any other packaging depending on your retailer.

For retail orders, please go to <https://www.espressif.com/en/company/contact/buy-a-sample>.

Wholesale Orders If you order in bulk, the boards come in large cardboard boxes.

For wholesale orders, please go to <https://www.espressif.com/en/contact-us/sales-questions>.

1.1.2 Hardware Reference

Block Diagram

The block diagram below shows the components of ESP32-5-DevKitC-1 and their interconnections.

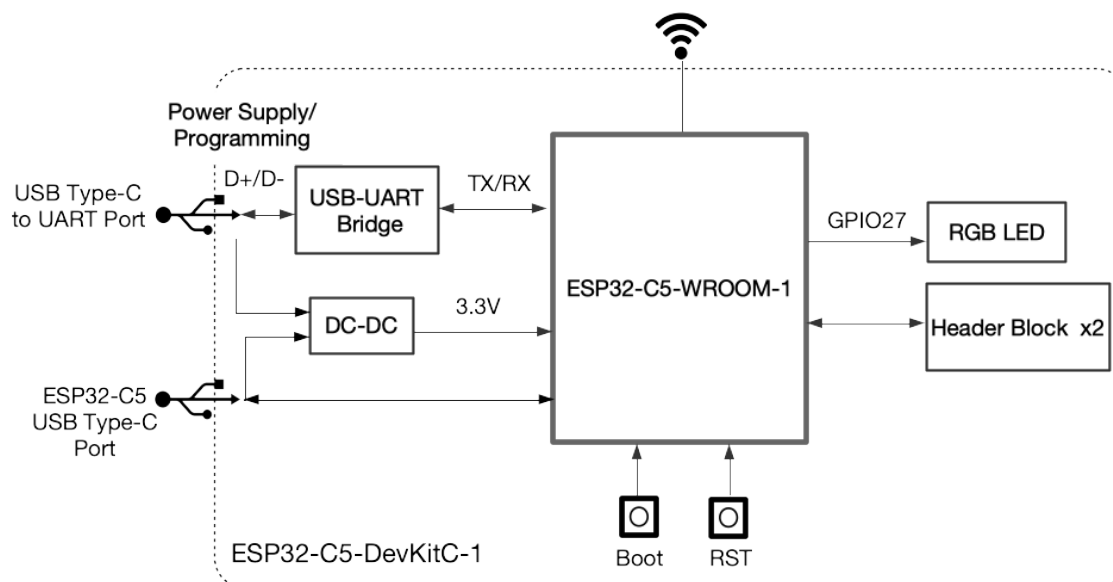

Fig. 3: ESP32-C5-DevKitC-1 (click to enlarge)

Power Supply Options

There are three mutually exclusive ways to provide power to the board:

- USB Type-C to UART port and ESP32-C5 USB Type-C port (either one or both), default power supply (recommended)
- 5V and GND pin headers
- 3V3 and GND pin headers

Current Measurement

The J5 headers on ESP32-C5-DevKitC-1 (see J5 in Figure [ESP32-C5-DevKitC-1 - front](#)) can be used for measuring the current drawn by the ESP32-C5-WROOM-1(U) module:

- Remove the jumper: Power supply between the module and peripherals on the board is cut off. To measure the module's current, connect the board with an ammeter via J5 headers.
- Apply the jumper (factory default): Restore the board's normal functionality.

Note: When using 3V3 and GND pin headers to power the board, please remove the J5 jumper, and connect an ammeter in series between the external power supply and the 3V3 pin header to measure the module's current. This is because the 3V3 pin header supplies power directly to the module, bypassing the J5 headers. Removing the J5 jumper disconnects unnecessary circuits, allowing for a more accurate measurement of the module's current.

Header Block

The two tables below provide the **Name** and **Function** of the pin headers on both sides of the board (J1 and J3). The pin header names are shown in Figure [ESP32-C5-DevKitC-1 - front](#). The numbering is the same as in the [ESP32-](#)

C5-DevKitC-1 Schematic v1.2 (PDF).

J1

No.	Name	Type ¹	Function
1	3V3	P	3.3 V power supply
2	RST	I	High: enables the chip; Low: disables the chip.
3	2	I/O/T	MTMS ³ , GPIO2, LP_GPIO2, LP_UART_RTSN, LP_I2C_SDA, ADC1_CH1, FSPIQ
4	3	I/O/T	MTDI ³ , GPIO3, LP_GPIO3, LP_UART_CTSN, LP_I2C_SCL, ADC1_CH2
5	0	I/O/T	GPIO0, XTAL_32K_P, LP_GPIO0, LP_UART_DTRN
6	1	I/O/T	GPIO1, XTAL_32K_N, LP_GPIO1, LP_UART_DSRN, ADC1_CH0
7	6	I/O/T	GPIO6, LP_GPIO6, ADC1_CH5, FSPICLK
8	7	I/O/T	GPIO7 ³ , FSPID, SDIO_DATA1
9	8	I/O/T	GPIO8, PAD_COMP0, SDIO_DATA0
10	9	I/O/T	GPIO9, PAD_COMP1, SDIO_CLK
11	10	I/O/T	GPIO10, FSPICS0, SDIO_CMD
12	26	I/O/T	GPIO26 ³ ,
13	25	I/O/T	GPIO25 ³ ,
14	5V	P	5 V power supply
15	G	G	Ground
16	NC	–	No connection

J3

No.	Name	Type	Function
1	G	G	Ground
2	TX	I/O/T	U0TXD, GPIO11
3	RX	I/O/T	U0RXD, GPIO12
4	24	I/O/T	GPIO24
5	23	I/O/T	GPIO23
6	NC/15	I/O/T	No connection/GPIO15 ⁴
7	27	I/O/T	GPIO27 ²³
8	4	I/O/T	MTCK, GPIO4, LP_GPIO4, LP_UART_RXD, ADC1_CH3, FSPIHD
9	5	I/O/T	MTDO, GPIO5, LP_GPIO5, LP_UART_TXD, ADC1_CH4, FSPIWP
10	NC	–	No connection
11	28	I/O/T	GPIO28 ³
12	G	G	Ground
13	14	I/O/T	GPIO14, USB_D+, SDIO_DATA2
14	13	I/O/T	GPIO13, USB_D-, SDIO_DATA3
15	G	G	Ground
16	NC	–	No connection

Pin Layout**1.1.3 Hardware Revision Details**

¹ P: Power supply; I: Input; O: Output; T: High impedance.

³ MTMS, MTDI, GPIO7, GPIO25, GPIO26, GPIO27, and GPIO28 are strapping pins of the ESP32-C5 chip. These pins are used to control several chip functions depending on binary voltage values applied to the pins during chip power-up or system reset. For description and application of the strapping pins, please refer to [ESP32-C5 Datasheet](#) > Section *Boot Configurations*.

⁴ In modules integrated with SPI PSRAM, this pin is already used for SPICS1 function, thus unavailable for external use. In modules without SPI PSRAM, this pin can be used as GPIO15.

² Used to drive the RGB LED.

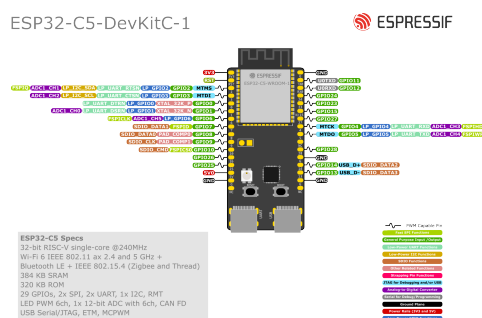

Fig. 4: ESP32-C5-DevKitC-1 Pin Layout (click to enlarge)

ESP32-C5-DevKitC-1 v1.2

For boards with the PW number of and after PW-2025-04-0446, J1 and J3 functions are updated. See details in Section [Header Block](#).

Note: The PW number can be found in the product label on the large cardboard boxes for wholesale orders.

ESP32-C5-DevKitC-1 v1.1

Initial release

1.1.4 Related Documents

Please download the following documents from the [HTML version of esp-dev-kits Documentation](#).

- [ESP32-C5 Datasheet \(PDF\)](#)
- [ESP32-C5-WROOM-1 & ESP32-C5-WROOM-1U Datasheet \(PDF\)](#)
- [ESP32-C5-DevKitC-1 Schematic v1.2 \(PDF\)](#)
- [ESP32-C5-DevKitC-1 PCB Layout v1.2 \(PDF\)](#)
- [ESP32-C5-DevKitC-1 Dimensions v1.2 \(PDF\)](#)
- [ESP32-C5-DevKitC-1 Dimensions v1.2 source file \(DXF\)](#) - You can view it with [Autodesk Viewer](#) online

For further design documentation for the board, please contact us at sales@espressif.com.

ESP32-C5-DevKitC-1 v1.1

Latest version: [ESP32-C5-DevKitC-1 v1.2](#)

This user guide will help you get started with ESP32-C5-DevKitC-1 and will also provide more in-depth information.

The ESP32-C5-DevKitC-1 is an entry-level development board based on the general-purpose module ESP32-C5-WROOM-1. This board integrates complete Wi-Fi, Bluetooth (LE), Zigbee, and Thread functions.

Most of the I/O pins are broken out to the pin headers on both sides for easy interfacing. Developers can either connect peripherals with jumper wires or mount ESP32-C5-DevKitC-1 on a breadboard.

The document consists of the following major sections:

- [Getting Started](#): Overview of ESP32-C5-DevKitC-1 and hardware/software setup instructions to get started.
- [Hardware Reference](#): More detailed information about the ESP32-C5-DevKitC-1's hardware.
- [Hardware Revision Details](#): Information about revision history, known issues, and links to user guides for previous versions (if any).

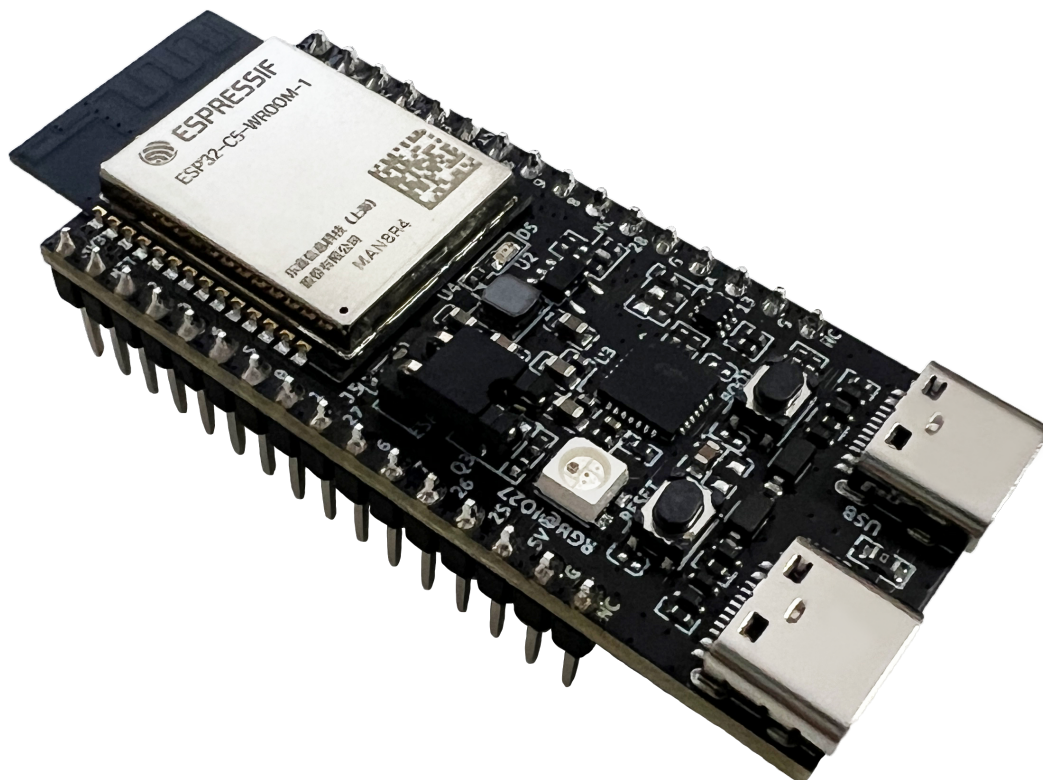

Fig. 5: ESP32-C5-DevKitC-1

- [Related Documents](#): Links to related documentation.

Getting Started This section provides a brief introduction to ESP32-C5-DevKitC-1, introducing how to perform the initial hardware setup and how to flash firmware onto the board.

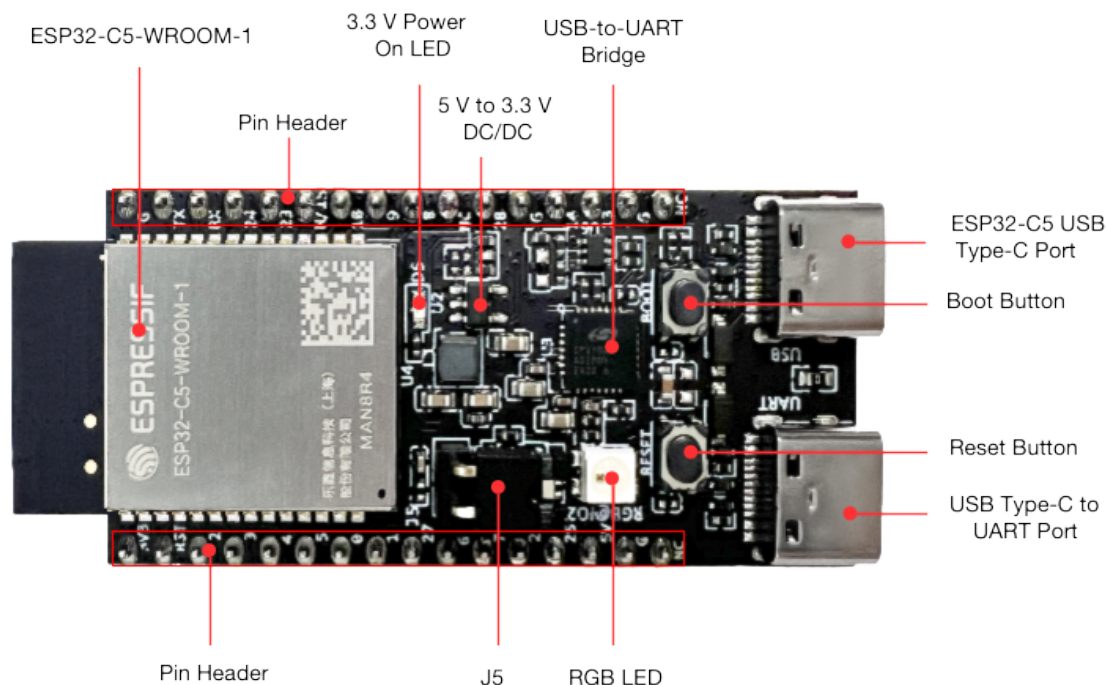

Fig. 6: ESP32-C5-DevKitC-1 - front

Description of Components The following list provides a description of the key components on the board in a clockwise direction.

Key Component	Description
ESP32-C5-WROOM-1	ESP32-C5-WROOM-1 is a general-purpose module supporting Wi-Fi 6 in 2.4 & 5 GHz dual-band (802.11ax), Bluetooth® 5 (LE), Zigbee, and Thread (802.15.4) with on-board PCB antenna.
Pin Header	All available GPIO pins (except for the SPI bus for flash) are broken out to the pin headers on the board.
5 V to 3.3 V DC/DC	Power regulator that converts a 5 V supply into a 3.3 V output.
3.3 V Power On LED	Turns on when the the board is connected to USB power.
USB-to-UART Bridge	Single-chip USB-to-UART bridge offering transfer rate up to 3 Mbps.
ESP32-C5 USB Type-C Port	The USB Type-C port on the ESP32-C5 chip supports USB 2.0 full speed, with a data transfer rate of up to 12 Mbps. Note that this port does not support the 480 Mbps high-speed transfer mode. This port is used for power supply to the board, flashing applications to the chip, and communication with the chip via USB protocols, as well as for JTAG debugging.
Boot Button	Download button. Holding down Boot and then pressing Reset initiates Firmware Download mode for downloading firmware through the serial port.
Reset Button	Press this button to restart the system.
USB Type-C to UART Port	Used for power supply to the board, flashing applications to the chip, as well as communication with chip ESP32-C5 via the on-board USB-to-UART bridge.
RGB LED	Addressable RGB LED, driven by GPIO27.
J5	Used for current measurement. See details in Section Current Measurement .

Start Application Development Before powering up your ESP32-C5-DevKitC-1, please make sure that it is in good condition with no obvious sign of damage.

Required Hardware

- ESP32-C5-DevKitC-1
- USB-A to USB-C cable
- Computer running Windows, Linux, or macOS

Note: Be sure to use a good quality USB cable. Some cables are for charging only and do not provide the needed data lines nor work for programming the boards.

Software Setup Please proceed to [ESP-IDF Get Started](#), which will help you set up the development environment quickly and then flash an application example onto your board.

ESP32-C5-DevKitC-1 v1.1 is equipped with ESP32-C5 chip revision v0.1. Support for ESP32-C5 v0.1 in ESP-IDF has been discontinued as of commit [16d7910](#). For ESP32-C5 v0.1 chip users, please use the last supported commit [d930a38](#) for evaluation. See details in [ESP32-C5 support status \(IDFGH-13076\)](#).

Contents and Packaging

Retail orders If you order a few samples, each ESP32-C5-DevKitC-1 comes in an individual package in either an antistatic bag or any other packaging depending on your retailer.

For retail orders, please go to <https://www.espressif.com/en/company/contact/buy-a-sample>.

Wholesale Orders If you order in bulk, the boards come in large cardboard boxes.

For wholesale orders, please go to <https://www.espressif.com/en/contact-us/sales-questions>.

Hardware Reference

Block Diagram The block diagram below shows the components of ESP32-5-DevKitC-1 and their interconnections.

Power Supply Options There are three mutually exclusive ways to provide power to the board:

- USB Type-C to UART port and ESP32-C5 USB Type-C port (either one or both), default power supply (recommended)
- 5V and GND pin headers
- 3V3 and GND pin headers

Current Measurement The J5 headers on ESP32-C5-DevKitC-1 (see J5 in Figure [ESP32-C5-DevKitC-1 - front](#)) can be used for measuring the current drawn by the ESP32-C5-WROOM-1 module:

- Remove the jumper: Power supply between the module and peripherals on the board is cut off. To measure the module's current, connect the board with an ammeter via J5 headers.
- Apply the jumper (factory default): Restore the board's normal functionality.

Note: When using 3V3 and GND pin headers to power the board, please remove the J5 jumper, and connect an ammeter in series between the external power supply and the 3V3 pin header to measure the module's current. This

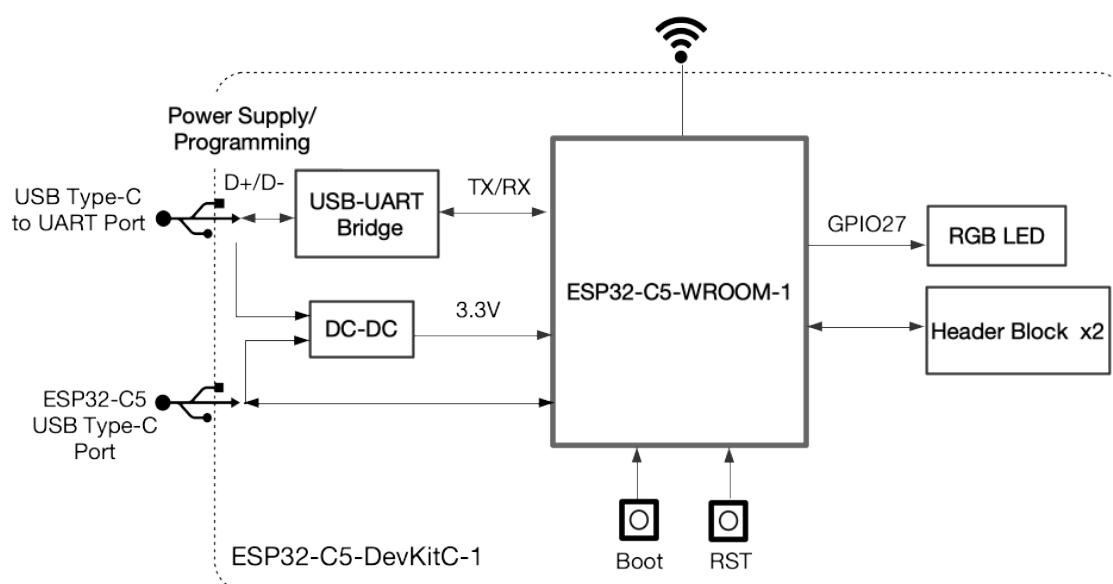

Fig. 7: ESP32-C5-DevKitC-1 (click to enlarge)

is because the 3V3 pin header supplies power directly to the module, bypassing the J5 headers. Removing the J5 jumper disconnects unnecessary circuits, allowing for a more accurate measurement of the module's current.

Header Block The two tables below provide the **Name** and **Function** of the pin headers on both sides of the board (J1 and J3). The pin header names are shown in Figure [ESP32-C5-DevKitC-1 - front](#). The numbering is the same as in the [ESP32-C5-DevKitC-1 Schematic](#) (PDF).

J1

No.	Name	Type ¹	Function
1	3V3	P	3.3 V power supply
2	RST	I	High: enables the chip; Low: disables the chip.
3	2	I/O/T	MTMS ³ , GPIO2, LP_GPIO2, LP_UART_RTSN, ADC1_CH1, FSPIQ
4	3	I/O/T	MTDI, GPIO3, LP_GPIO3, LP_UART_CTSN, ADC1_CH2
5	4	I/O/T	MTCK, GPIO4, LP_GPIO4, LP_UART_RXD, ADC1_CH3, FSPIHD
6	5	I/O/T	MTDO, GPIO5, LP_GPIO5, LP_UART_TXD, ADC1_CH4, FSPIWP
7	0	I/O/T	GPIO0, XTAL_32K_P, LP_GPIO0, LP_UART_DTRN
8	1	I/O/T	GPIO1, XTAL_32K_N, LP_GPIO1, LP_UART_DSRN, ADC1_CH0
9	27	I/O/T	GPIO27 ^{2,3}
10	6	I/O/T	GPIO6, LP_GPIO6, LP_I2C_SDA, ADC1_CH5, FSPICKL
11	7	I/O/T	GPIO7 ³ , LP_GPIO7, LP_I2C_SCL, FSPID
12	26	I/O/T	GPIO26
13	25	I/O/T	GPIO25
14	5V	P	5 V power supply
15	G	G	Ground
16	NC	–	No connection

¹ P: Power supply; I: Input; O: Output; T: High impedance.

³ MTMS, GPIO7, GPIO27, and GPIO28 are strapping pins of the ESP32-C5 chip. These pins are used to control several chip functions depending on binary voltage values applied to the pins during chip power-up or system reset.

² Used to drive the RGB LED.

J3

No.	Name	Type	Function
1	G	G	Ground
2	TX	I/O/T	U0TXD, GPIO11
3	RX	I/O/T	U0RXD, GPIO12
4	24	I/O/T	GPIO24
5	23	I/O/T	GPIO23
6	NC/15	I/O/T	No connection/GPIO15 ⁴
7	10	I/O/T	GPIO10, FSPICS0
8	9	I/O/T	GPIO9, PAD_COMP1
9	8	I/O/T	GPIO8, PAD_COMP0
10	NC	–	No connection
11	28	I/O/T	GPIO28 ³
12	G	G	Ground
13	14	I/O/T	GPIO14, USB_D+
14	13	I/O/T	GPIO13, USB_D-
15	G	G	Ground
16	NC	–	No connection

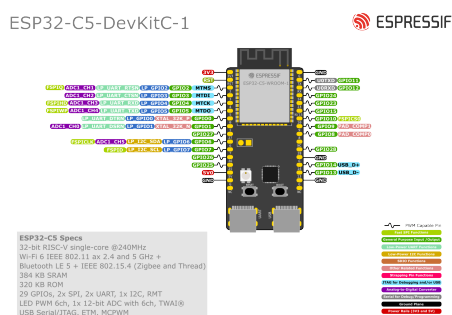

Fig. 8: ESP32-C5-DevKitC-1 Pin Layout (click to enlarge)

Pin Layout

Hardware Revision Details This is the first revision of this board released.

Related Documents Please download the following documents from [the HTML version of esp-dev-kits Documentation](#).

- [ESP32-C5-DevKitC-1 Schematic \(PDF\)](#)
- [ESP32-C5-DevKitC-1 PCB Layout \(PDF\)](#)
- [ESP32-C5-DevKitC-1 Dimensions \(PDF\)](#)
- [ESP32-C5-DevKitC-1 Dimensions source file \(DXF\)](#) - You can view it with [Autodesk Viewer](#) online

For further design documentation for the board, please contact us at sales@espressif.com.

⁴ In modules integrated with SPI PSRAM, this pin is already used for SPICS1 function, thus unavailable for external use. In modules without SPI PSRAM, this pin can be used as GPIO15.

Chapter 2

ESP-SensairShuttle

ESP-SensairShuttle is a development board jointly launched by Espressif and **Bosch Sensortec** for **motion sensing** and **large language model human-computer interaction** scenarios, dedicated to promoting the deep integration of multimodal sensing and intelligent interaction technologies. The platform covers typical application scenarios such as **AI toys, smart homes, sports health, and smart offices**, supporting a complete technical chain from environmental sensing, behavior understanding to intelligent feedback, providing a more natural, real-time, and intelligent interaction experience for next-generation intelligent terminals.

The application examples for the development board are stored in the [examples](#) folder.

Note: Please check the silkscreen version number on the mainboard (in the white circle at the top right corner of the front or back of the mainboard) to confirm your development board version. For v1.0 development boards, please refer to [ESP-SensairShuttle v1.0](#).

2.1 ESP-SensairShuttle v1.0

Note: Please check the silkscreen version number on the mainboard (in the white circle at the top right corner of the front or back of the mainboard) to confirm your development board version. For v1.0 development boards, please refer to this user guide.

This guide will help you get started with ESP-SensairShuttle quickly and provide detailed information about this development board.

ESP-SensairShuttle is a development board jointly launched by Espressif and **Bosch Sensortec** for **motion sensing** and **large language model human-computer interaction** scenarios, dedicated to promoting the deep integration of multimodal sensing and intelligent interaction technologies. The platform covers typical application scenarios such as **AI toys, smart homes, sports health, and smart offices**, supporting a complete technical chain from environmental sensing, behavior understanding to intelligent feedback, providing a more natural, real-time, and intelligent interaction experience for next-generation intelligent terminals.

ESP-SensairShuttle uses Espressif's **ESP32-C5-WROOM-1-N16R8** module as the main controller, featuring dual-band Wi-Fi 6 (802.11ax) at 2.4 & 5 GHz, Bluetooth® 5 (LE), Zigbee, and Thread (802.15.4) wireless communication capabilities. In addition, the mainboard provides rich peripheral interfaces, including [Bosch Sensortec Shuttle Board](#) (only supports shuttle board 3.0 version) interface, **microphone and speaker interfaces**, and **battery power interface**. Users can flexibly achieve multi-dimensional sensing such as **air quality, gesture actions, attitude direction, and magnetic field information** by replacing different Shuttle sensor daughterboards (Espressif officially supports

BME690 and **BMI270 & BMM350** daughterboards), suitable for teaching demonstrations, algorithm verification, and multi-scenario prototype development.

In terms of audio, ESP-SensairShuttle supports external microphones and speakers, which can seamlessly connect to various **large language models** to achieve natural and smooth AI voice interaction capabilities, suitable for voice interaction products that require large model empowerment such as **AI toys, smart speakers, and smart control panels**.

This guide includes the following content:

- *Getting Started*: Briefly introduces the development board and hardware and software setup guides.
- *Hardware Reference*: Details the hardware of the development board.
- *Hardware Revision History*: Introduces hardware revision history and known issues (if any).
- *Related Documents*: Lists links to related documents.

Note: For instructions on using the factory firmware, please refer to [ESP-SensairShuttle User Guide](#).

2.1.1 Getting Started

This section will briefly introduce ESP-SensairShuttle and explain how to flash firmware on ESP-SensairShuttle and related preparation work.

Component Overview

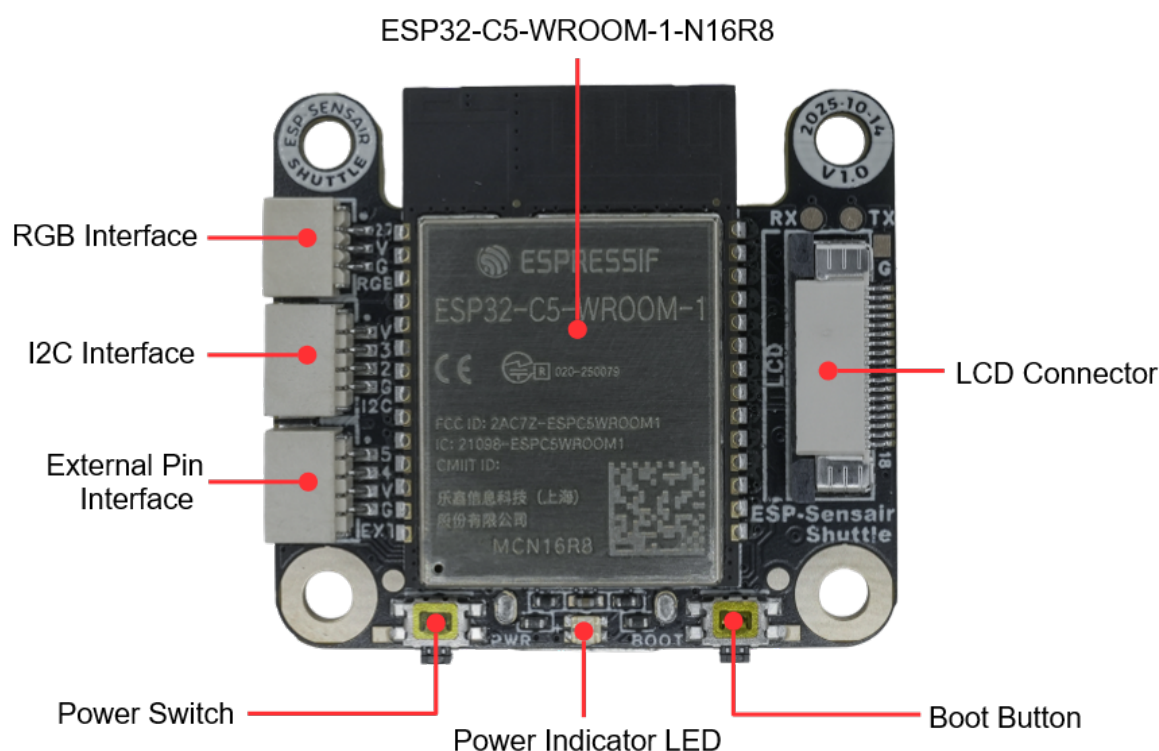

Fig. 1: SensairShuttle-Mainboard PCB Front View (Click to enlarge)

The main components on the front PCB are introduced in clockwise order below.

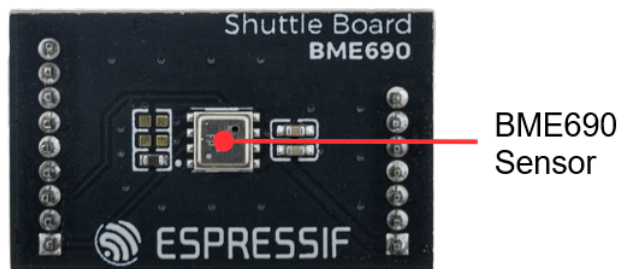

Fig. 2: ShuttleBoard-BME690 PCB Front View (Click to enlarge)

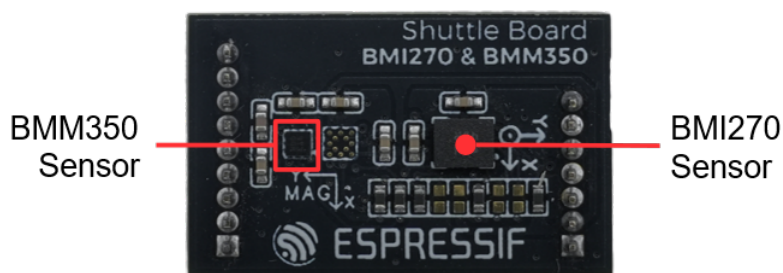

Fig. 3: ShuttleBoard-BMI270&BMM350 PCB Front View (Click to enlarge)



Fig. 4: ESP-SensairShuttle LCD Screen Photo (Click to enlarge)

Main Component	Description
MainBoard	
External Pin Interface	4-pin external pin interface, from top to bottom: GPIO5, GPIO4, VDD, GND. Note: GPIO5 is not available by default. To use it, please install the R14 resistor.
I2C Interface (External I2C Interface)	4-pin external I2C interface that can connect to devices supporting I2C protocol communication.
RGB Interface (External RGB Strip Interface)	3-pin external RGB strip interface that can connect to WS2812 and other RGB strips.
ESP32-C5-WROOM-1-N16R8	Main control module, integrated with 16 MB Flash and 8 MB PSRAM, featuring dual-band Wi-Fi 6 (802.11ax) at 2.4 & 5 GHz, Bluetooth® 5 (LE), Zigbee, and Thread (802.15.4) wireless communication capabilities.
LCD Connector	Used to connect LCD screen with a resolution of 240(H) x 284(V).
Boot Button	Used to manually enter download mode, can also be used as a regular function button.
Power Indicator LED	Used to indicate device power status. For indicator status details, please refer to the Power Options section.
Power Switch	Used to control device power on/off. Click the power switch to toggle the power state.
ShuttleBoard-BME690	
BME690 Sensor	Bosch BME690 gas sensor that can detect air quality, including temperature, humidity, pressure, and gas resistance, supporting I2C and SPI protocol communication.
ShuttleBoard-BMI270&BMM350	
BMI270 Sensor	Bosch BMI270 inertial measurement unit that can detect three-axis acceleration and three-axis angular velocity, supporting I2C and SPI protocol communication.
BMM350 Sensor	Bosch BMM350 magnetometer that can detect three-axis magnetic field strength, supporting I2C protocol communication.
LCD Screen	Matching LCD screen, model ST7789P3, size 1.83 inches, resolution 240(H) x 284(V), using 4-line SPI interface communication. The screen is connected to the mainboard through the LCD connector, and supports power control via GPIO5 (PWR_CTRL).

The main components on the back PCB are introduced in clockwise order below.

Main Component	Description
MainBoard	
Battery Connector	Battery connector that can connect to an external 3.7V lithium battery, using HC-1.25-2P wire-to-board connector.
Mic Connector	2-wire microphone connector that can connect to an external analog microphone, using HC-1.25-2P wire-to-board connector.
Shuttle Board Connector	9+7 pin 1.27mm female header connector that can connect to ShuttleBoard-BME690, ShuttleBoard-BMI270&BMM350 and other sensor daughterboards.
Speaker Connector	2-wire speaker connector that can connect to an external speaker, using HC-1.25-2P wire-to-board connector.
Type-C Port (USB-C Interface)	USB-C interface for power supply, program flashing, and debugging, supporting lithium battery charging.
ShuttleBoard-BME690	Pin definitions for the sensor daughterboard are marked in the figure.
ShuttleBoard-BMI270&BMM350	Pin definitions for the sensor daughterboard are marked in the figure.

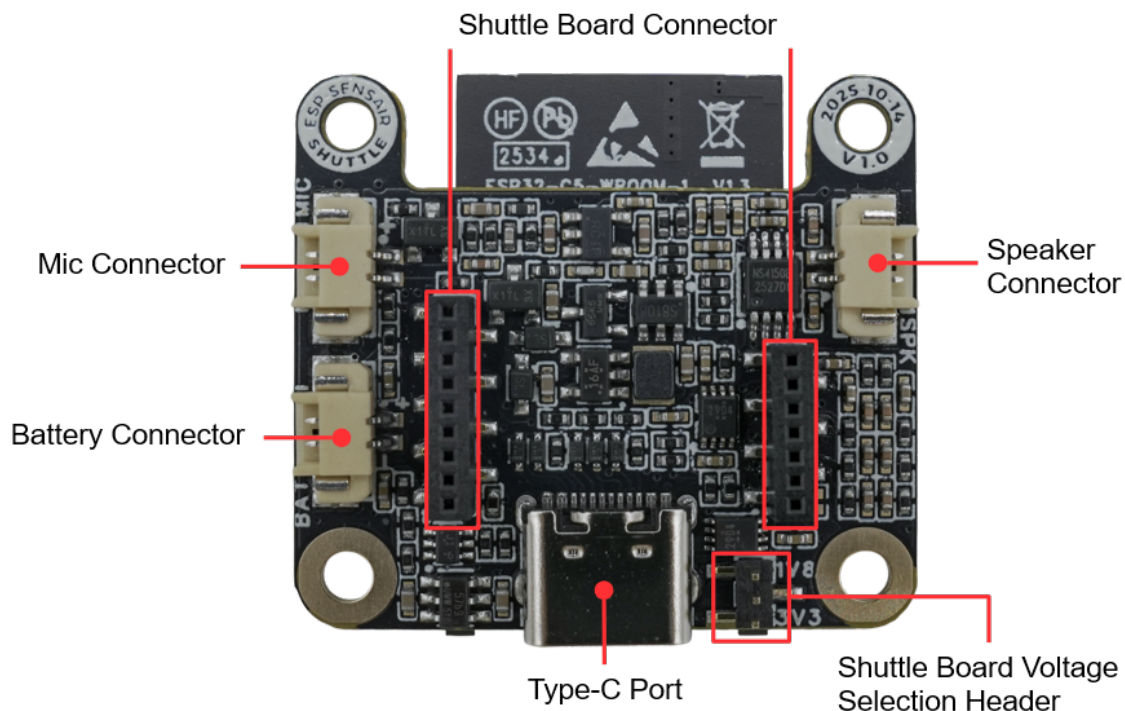

Fig. 5: SensairShuttle-Mainboard PCB Back View (Click to enlarge)

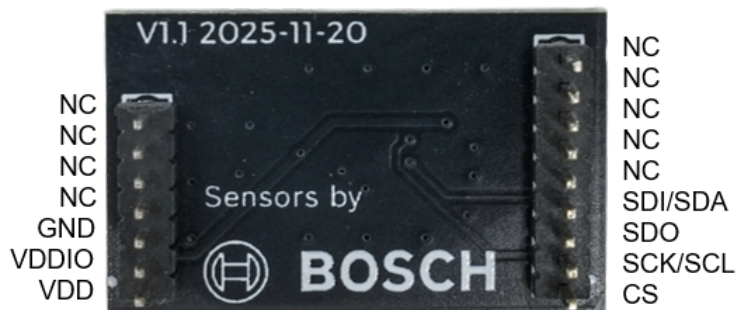

Fig. 6: ShuttleBoard-BME690 PCB Back View (Click to enlarge)



Fig. 7: ShuttleBoard-BMI270&BMM350 PCB Back View (Click to enlarge)

Application Examples

The following are application examples for the development board:

- [ESP-SensairShuttle Factory Demo](#) - A full-featured demo system based on the ESP-Brookesia framework, showcasing an app-based UI management system and multiple demo applications (e.g., compass, temperature & air quality monitoring, gesture recognition).

For more examples and the latest updates, please refer to the [examples](#) folder.

To try the examples or develop custom applications, please follow the steps in the [Start Development](#) section.

Start Development

Before powering on, please ensure that ESP-SensairShuttle is intact.

Required Hardware

- ESP-SensairShuttle mainboard, ShuttleBoard-BME690 daughterboard, ShuttleBoard-BMI270&BMM350 daughterboard, LCD screen
- USB cable
- Computer (Windows, Linux, or macOS)

Note: Please ensure you use an appropriate USB cable. Some cables can only be used for charging and cannot be used for data transmission and programming.

Hardware Setup

LCD Screen Cable Installation Before starting to use the development board, please follow the steps below to install the LCD screen cable:

1. **Confirm Cable Orientation:** Place the LCD screen cable with the gold fingers facing up, ensuring the cable orientation is correct (the pin number [18] on the screen cable should correspond to the pin number [18] on the PCB).
2. **Insert Cable:** First, release the black lock of the LCD connector, then insert the screen cable into the LCD connector on the mainboard. When inserting, ensure the screen cable is aligned with the connector. You can use **tweezers** to assist if it is inconvenient to install by hand.
3. **Lock Connector:** Lock the black lock of the LCD connector to ensure the screen cable is securely connected.

Warning:

- Do not use excessive force when installing the cable to avoid damaging the cable or connector.
- Ensure the cable orientation is correct. An incorrect orientation will cause the screen not to light up.
- If you need to remove the cable, first unlock the connector, then gently pull it out. Avoid directly pulling the cable.

USB Connection Connect ESP-SensairShuttle to your computer using a USB cable, and flash firmware, debug, and power supply through the Type-C (USB-C Interface).

Software Setup Please visit the [ESP-IDF Getting Started](#) section to learn how to quickly set up the development environment and flash applications to your development board.

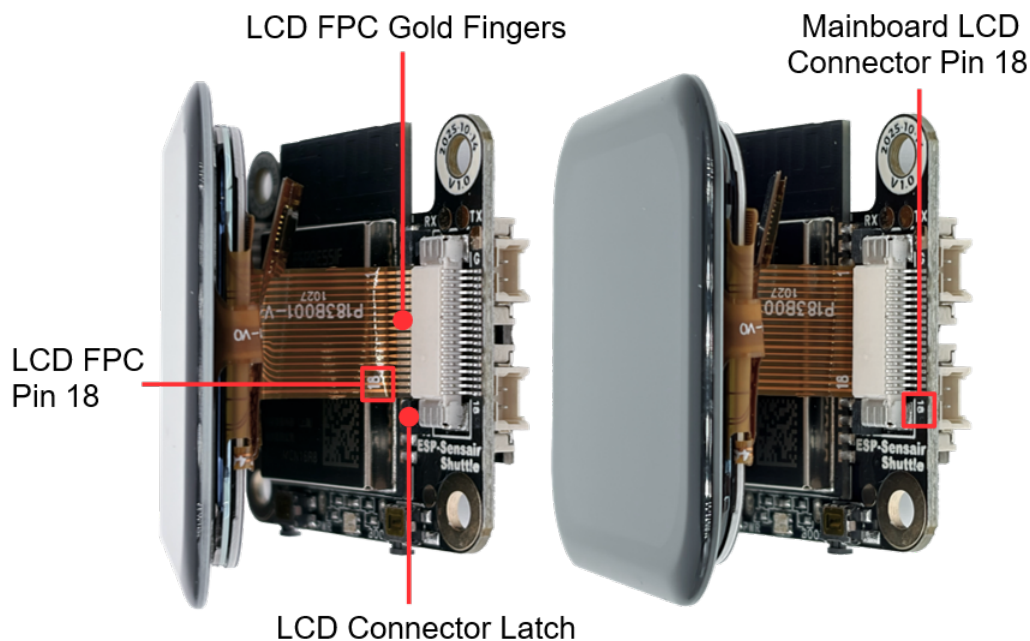

Fig. 8: LCD Screen Cable Installation Diagram (Click to enlarge)

Note: The development board uses a USB port to communicate with the computer. Most operating systems (Windows, Linux, macOS) have the required drivers pre-installed, and the development board can be automatically recognized after insertion. If the device cannot be recognized or a serial connection cannot be established, please refer to [Establish Serial Connection](#) for detailed steps on installing drivers.

2.1.2 Hardware Reference

Function Block Diagram

The main components and connection methods of ESP-SensairShuttle are shown in the figure below.

Power Options

The development board can be powered by the following methods:

1. Power via Type-C (USB-C Interface)
When using this method, connect the Type-C interface on the device using a USB Type-C cable. If no lithium battery is installed, the power indicator LED will be green. If a lithium battery is installed, press the POWER button to turn on the device. At this time, the power indicator LED will be yellow (battery is charging) or green (battery is fully charged).
2. Power via Battery
The device can connect to an external 3.7V lithium battery. Press the POWER button to power the device. The power indicator LED will be green when the device is on, and off when the device is off.

Type-C Interface

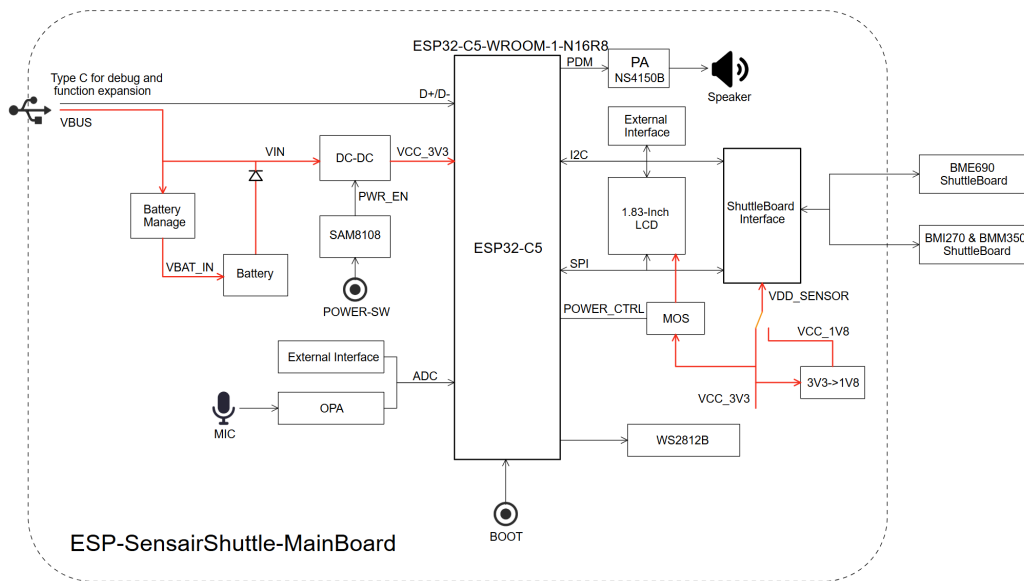

Fig. 9: ESP-SensairShuttle Function Block Diagram (Click to enlarge)

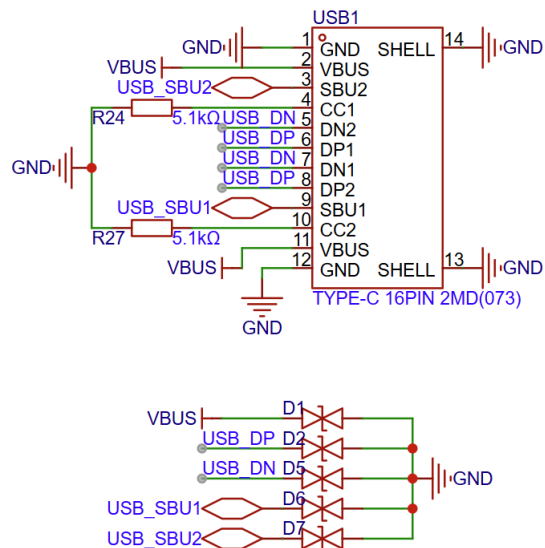

Fig. 10: Type-C Interface Circuit Diagram (Click to enlarge)

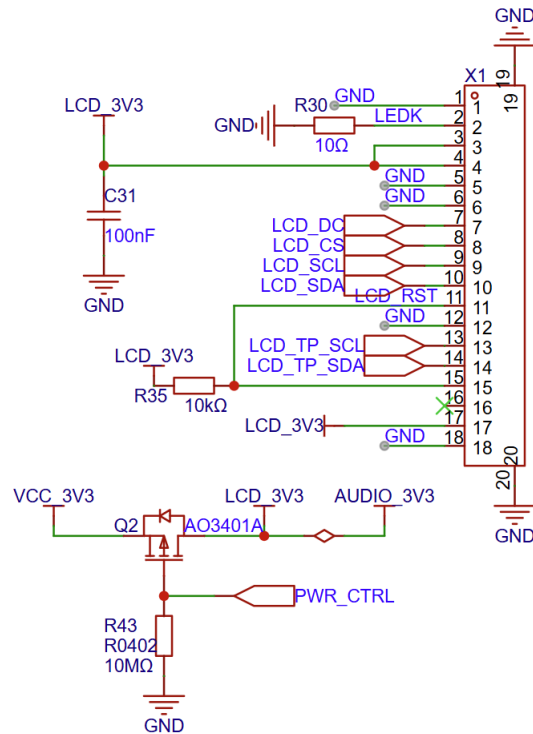

Fig. 11: LCD Interface Circuit Diagram (Click to enlarge)

LCD Interface

The X1 interface is the LCD screen interface in use. The matching LCD screen specifications for this development board are as follows:

- **Screen Size:** 1.83 inches
- **Resolution:** 240(H) x 284(V)
- **Driver Chip:** ST7789P3
- **Communication Interface:** 4-line SPI Interface
- **Power Control:** Supports controlling screen power on/off via PWR_CTRL (GPIO5)

For more detailed information, please refer to the [Display Specification](#).

Power Switch Circuit

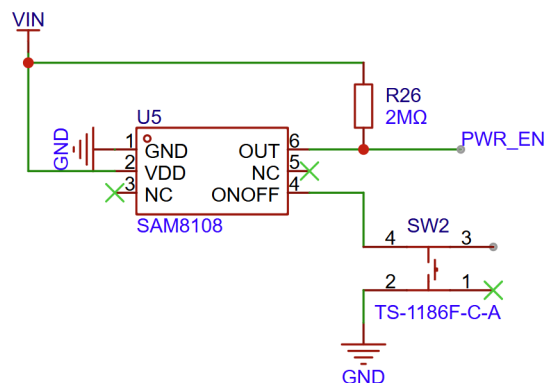

Fig. 12: Power Switch Circuit Diagram (Click to enlarge)

Battery Charging Circuit

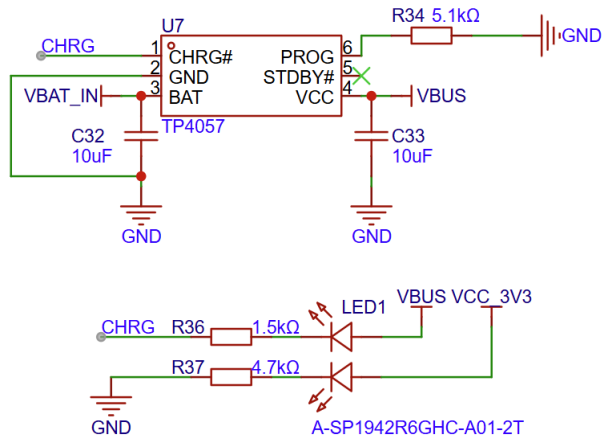

Fig. 13: Battery Charging Circuit Diagram (Click to enlarge)

Shuttle Board Interface Circuit

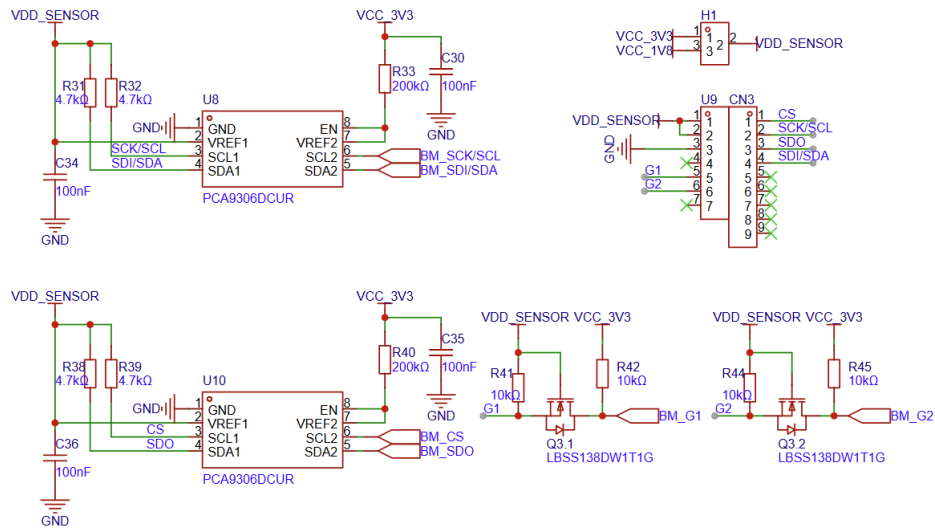

Fig. 14: Shuttle Board Interface Circuit Diagram (Click to enlarge)

I2C/RGB/External Pin Interface

2.1.3 Hardware Revision History

No revision history.

2.1.4 Related Documents

- ESP32-C5 Datasheet (PDF)
- ESP32-C5-WROOM-1 & ESP32-C5-WROOM-1U Datasheet (PDF)
- Espressif Product Selector
- ESP-SensairShuttle-Mainboard V1.0 Schematic (PDF)

External Interface

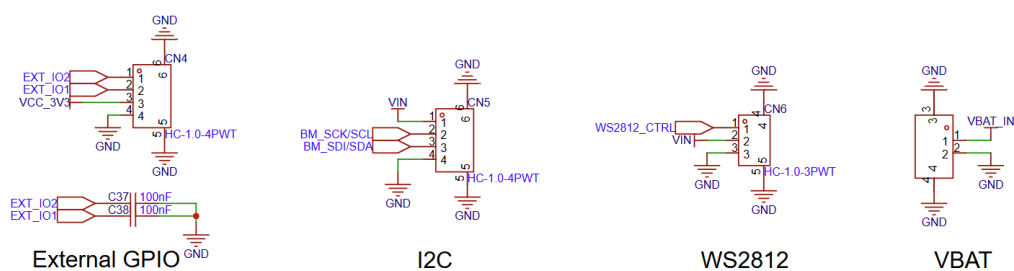
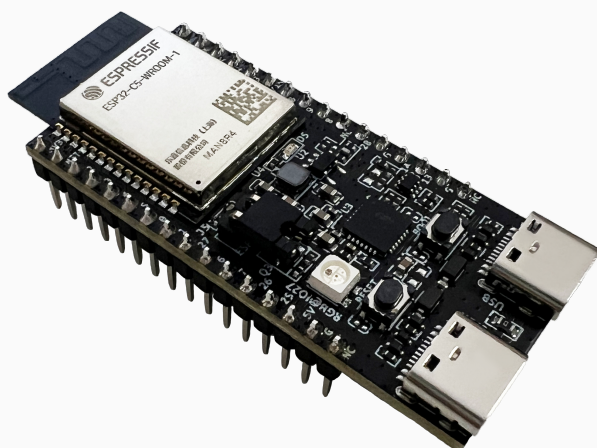

Fig. 15: I2C/RGB/External Pin Interface Circuit Diagram (Click to enlarge)

- [ESP-SensairShuttle-Mainboard V1.0 PCB Layout \(PDF\)](#)
- [ESP-SensairShuttle-ShuttleBoard-BME690 V1.0 Schematic \(PDF\)](#)
- [ESP-SensairShuttle-ShuttleBoard-BME690 V1.0 PCB Layout \(PDF\)](#)
- [ESP-SensairShuttle-ShuttleBoard-BMI270&BMM350 V1.0 Schematic \(PDF\)](#)
- [ESP-SensairShuttle-ShuttleBoard-BMI270&BMM350 V1.0 PCB Layout \(PDF\)](#)
- [Display Specification \(PDF\)](#)
- [Gas Sensor BME690 Official Data Sheet](#)
- [Inertial Measurement Unit BMI270 Official Data Sheet](#)
- [Magnetometer BMM350 Official Data Sheet](#)

ESP32-C5 Development Boards



ESP32-C5-DevKitC-1

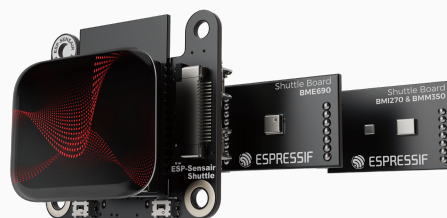

ESP-SensairShuttle

Chapter 3

Related Documentation and Resources

3.1 Developer Zone

- [ESP-IDF Programming Guide](#) –Extensive documentation for the ESP-IDF development framework.
- [ESP-IoT-Solution Programming Guide](#) - Extensive documentation for the ESP-IoT-Solution development framework.
- [ESP-FAQ](#) - A summary document of frequently asked questions released by Espressif.
- ESP-IDF and other development frameworks on GitHub.
<https://github.com/espressif>
- ESP32 BBS Forum –Engineer-to-Engineer (E2E) Community for Espressif products where you can post questions, share knowledge, explore ideas, and help solve problems with fellow engineers.
<https://esp32.com/>
- The ESP Journal –Best Practices, Articles, and Notes from Espressif folks.
<https://blog.espressif.com/>
- See the tabs SDKs and Demos, Apps, Tools, AT Firmware.
<https://espressif.com/en/support/download/sdks-demos>

3.2 Products

- ESP32-C5 Series SoCs –Browse through all ESP32-C5 SoCs.
<https://espressif.com/en/products/socs?id=ESP32-C5>
- ESP32-C5 Series Modules –Browse through all ESP32-C5-based modules.
<https://espressif.com/en/products/modules?id=ESP32-C5>
- ESP32-C5 Series DevKits –Browse through all ESP32-C5-based devkits.
<https://espressif.com/en/products/devkits?id=ESP32-C5>
- ESP Product Selector –Find an Espressif hardware product suitable for your needs by comparing or applying filters.
<https://products.espressif.com/#/product-selector>

3.3 Contact Us

- See the tabs Sales Questions, Technical Enquiries, Circuit Schematic & PCB Design Review, Get Samples (Online stores), Become Our Supplier, Comments & Suggestions.
<https://espressif.com/en/contact-us/sales-questions>

Chapter 4

Disclaimer and Copyright Notice

Information in this document, including URL references, is subject to change without notice.

All third party's information in this document is provided as is with no warranties to its authenticity and accuracy.

No warranty is provided to this document for its merchantability, non-infringement, fitness for any particular purpose, nor does any warranty otherwise arising out of any proposal, specification or sample.

All liability, including liability for infringement of any proprietary rights, relating to use of information in this document is disclaimed. No licenses express or implied, by estoppel or otherwise, to any intellectual property rights are granted herein.

The Wi-Fi Alliance Member logo is a trademark of the Wi-Fi Alliance. The Bluetooth logo is a registered trademark of Bluetooth SIG.

All trade names, trademarks and registered trademarks mentioned in this document are property of their respective owners, and are hereby acknowledged.

Looking for pricing, stock, or lifecycle information?

Click below to explore more details on WIN SOURCE:

- ⊖ [View ESP32-C5HR8 on WIN SOURCE](#)
- ⊖ [Espressif Information](#)

Optimize Your Supply Chain with WIN SOURCE Solutions

- ✓ Global Sourcing Solution
- ✓ Obsolete Management
- ✓ Cost Control Management
- ✓ Shortage Management
- ✓ Alternative Solution
- ✓ Excess Inventory Management