



THE DATASHEET OF BSH205G2AR



5.7 kV rms/1.5 kV rms, Quad-Channel LVDS 2.5 Gigabit Isolators

FEATURES

- ▶ 5.7 kV rms and 1.5 kV rms LVDS isolators
- ▶ Complies with TIA/EIA-644-A LVDS signal levels
- ▶ Quad-channel configuration (ADN4622: 2 + 2, ADN4624: 4 + 0)
- ▶ Any data rate up to 2.5 Gbps switching with low jitter
 - ▶ 10 Gbps total bandwidth across four channels
 - ▶ 2.15 ns typical propagation delay
 - ▶ Typical jitter: 0.82 ps rms random, 40 ps total peak
- ▶ Lower power 1.8 V supplies
- ▶ ±8 kV IEC 61000-4-2 ESD protection across isolation barrier
- ▶ High common-mode transient immunity: 100 kV/μs typical
- ▶ 28-lead, wide-body, finer pitch SOIC_W_FP package with 8.3 mm creepage and clearance
 - ▶ UL 1577:
 - ▶ VISO= 5700 V rms for 1 minute
 - ▶ IEC/EN/CSA 62368-1
 - ▶ IEC/CSA 60601-1
 - ▶ IEC/CSA 61010-1
 - ▶ CQC GB4943.1
 - ▶ DIN EN IEC 60747-17 (VDE 0884-17)
 - ▶ DIN EN IEC 60747-17 (VDE 0884-17)
 - ▶ V_{IORM} = 849 V peak
- ▶ 32-lead LFCSP package with 1.27 mm creepage and clearance
 - ▶ UL 1577:
 - ▶ VISO = 1500 V rms for 1 minute
 - ▶ IEC/EN/CSA 62368-1
 - ▶ IEC/CSA 61010-1
 - ▶ CQC GB4943.1
 - ▶ DIN EN IEC 60747-17 (VDE 0884-17):
 - ▶ V_{IORM} = 560 V peak
- ▶ Enable or disable refresh (low-speed output correctness check)
- ▶ Operating temperature range: -40°C to +125°C

APPLICATIONS

- ▶ Isolated video and imaging data
- ▶ Analog front-end isolation
- ▶ Data plane isolation
- ▶ Isolated high speed clock and data links
- ▶ Multi-gigabit SERDES
- ▶ Board-to-board optical replacement (for example, short reach fiber)

FUNCTIONAL BLOCK DIAGRAMS

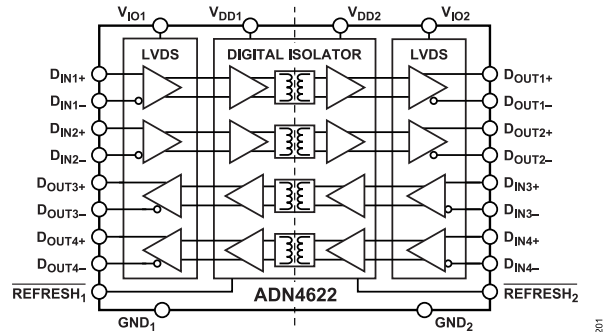

Figure 1. ADN4622 Functional Block Diagram with Two Forward and Two Reverse Channels

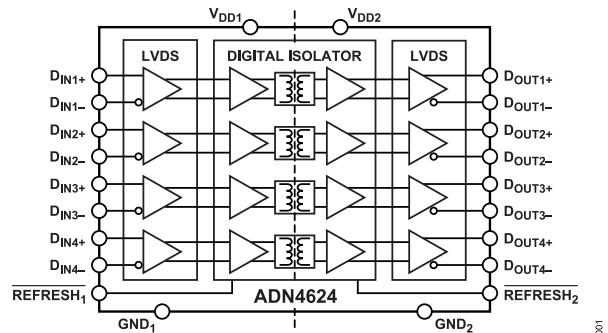

Figure 2. ADN4624 Functional Block Diagram with Four Forward Channels

GENERAL DESCRIPTION

The ADN4622/ADN4624¹ are quad-channel, signal isolated, low-voltage differential signaling (LVDS) buffers that operate at up to 2.5 Gbps with very low jitter. The devices integrate Analog Devices, Inc., iCoupler[®] technology, enhanced for high-speed operation to provide drop-in galvanic isolation of LVDS signal chains. AC coupling and/or level shifting to the LVDS receivers and from the LVDS drivers allows isolation of other high-speed signals such as current-mode logic (CML).

The ADN4622/ADN4624 include a refresh mechanism to monitor the input and output states and ensure they remain the same in the absence of data transitions. For lower power consumption and high-speed operation with low jitter, the LVDS and isolator circuits rely on 1.8 V supplies. The ADN4622/ADN4624 are fully specified over a wide industrial temperature range and are available in a 28-lead, wide-body, finer pitch SOIC_W_FP package with 8.3 mm creepage and clearance (for 5.7 kV rms or 8 kV_{PEAK} surge and impulse voltages and reinforced insulation at AC mains voltages) or 6 mm × 6 mm LFCSP package with 1.27 mm creepage and clearance (for basic/functional isolation).

¹ Protected by U.S. Patents 7,075,329; 9,941,565; and 10,205,442. Other patents are pending.

TABLE OF CONTENTS

Features.....	1	Electrostatic Discharge (ESD) Ratings.....	10
Applications.....	1	ESD Caution.....	10
Functional Block Diagrams.....	1	Pin Configurations and Function Descriptions.....	11
General Description.....	1	Typical Performance Characteristics.....	15
Specifications.....	4	Test Circuits and Switching Characteristics.....	20
Receiver Input Threshold Test Voltages.....	5	Theory of Operation.....	21
Timing Specifications.....	5	Isolation and Refresh.....	21
Insulation and Safety Related Specifications.....	6	Truth Table.....	21
Package Characteristics.....	6	Applications Information.....	22
Regulatory Information.....	7	PCB Layout.....	22
DIN EN IEC 60747-17 (VDE 0884-17)		Application Examples.....	22
Insulation Characteristics.....	8	Magnetic Field Immunity.....	23
Recommended Operating Conditions.....	9	Insulation Lifetime.....	24
Absolute Maximum Ratings.....	10	Outline Dimensions.....	26
Maximum Continuous Working Voltage.....	10	Ordering Guide.....	26
Thermal Resistance.....	10	Evaluation Boards.....	26

REVISION HISTORY**7/2025—Rev. C to Rev. D**

Changes to Features Section.....	1
Changes to Table 4	6
Changes to Table 6 and Table 7.....	7
Changes to Table 8.....	8
Changes to Application Examples Section and Figure 41	22

2/2025—Rev. B to Rev. C

Changes to Features Section.....	1
Changes to Table 4.....	6
Deleted Table 5; Renumbered Sequentially.....	6
Changes to Regulatory Information Section, Table 6, and Table 7.....	7
Changed DIN V VDE V 0884-11 (VDE V 0884-11) Insulation Characteristics (Pending) Section to DIN EN IEC 60747-17 (VDE 0884-17) Insulation Characteristics Section.....	8
Changes to Table 8 and Figure 3 Caption.....	8
Deleted Table 10.....	8
Changes to Figure 4 Caption.....	9
Changes to Table 11.....	10
Deleted Table 14.....	10
Added Figure 6 and Table 16; Renumbered Sequentially.....	12
Changes to Insulation Lifetime Section.....	24
Changes to Surface Tracking Section.....	24
Changes to Calculation and Use of Parameters Example Section.....	25

10/2022—Rev. A to Rev. B

Added ADN4622 and Figure 1; Renumbered Sequentially.....	1
Changes to Features Section and Figure 2 Caption.....	1
Changes to Specifications Section and Table 1 Section.....	4
Changes to Channel to Channel Parameter, Table 3.....	5
Changes to CSA (Pending), Standard Certification/Approval Column, Table 7.....	7

TABLE OF CONTENTS

Changes to Table 11.....	9
Added Table 12.....	10
Added Figure 5 and Table 18; Renumbered Sequentially.....	11
Changes to Figure 6 Caption and Table 19.....	13
Changes to Figure 7 Caption and Table 20.....	14
Added Figure 8, Figure 9, Figure 11, and Figure 12.....	15
Added Figure 14 and Figure 15.....	16
Changes to PCB Layout Section and Application Examples Section.....	22
Changes to Surface Tracking Section.....	24
Changes to Calculation and Use of Parameters Example Section.....	25
Changes to Ordering Guide.....	26
Changes to Evaluation Boards.....	26
10/2021—Rev. 0 to Rev. A	
Added 32-Lead LFCSP.....	1
Changes to Features Section and General Description Section.....	1
Changes to Channel to Channel Parameter and Additive Phase Jitter Parameter, Table 3.....	5
Added Table 5; Renumbered Sequentially.....	
Changes to Table 6.....	6
Added Table 8.....	
Change to Figure 2 Caption.....	8
Added Table 10 and Figure 3; Renumbered Sequentially.....	
Added Table 14.....	
Changes to Table 15.....	10
Added Table 17.....	10
Added Figure 5 and Table 19.....	14
Updated Outline Dimensions.....	26
Changes to Ordering Guide.....	26

4/2021—Revision 0: Initial Version

SPECIFICATIONS

For all minimum and maximum specifications, $V_{DD1} = 1.7\text{ V to }1.9\text{ V}$, $V_{DD2} = 1.7\text{ V to }1.9\text{ V}$, $V_{IO1} = 3\text{ V to }3.6\text{ V}$, $V_{IO2} = 3\text{ V to }3.6\text{ V}$, and $T_A = -40^\circ\text{C to }+125^\circ\text{C}$, unless otherwise noted. For all typical specifications, $V_{DD1} = V_{DD2} = 1.8\text{ V}$, $V_{IO1} = V_{IO2} = 3.3\text{ V}$, and $T_A = 25^\circ\text{C}$, unless otherwise noted. For all specifications, $\overline{\text{REFRESH}}_1 = \text{GND}_1$ and $\overline{\text{REFRESH}}_2 = \text{GND}_2$, unless otherwise noted.

Table 1. Specifications

Parameter	Symbol	Min	Typ	Max	Unit	Test Conditions/Comments
INPUTS (RECEIVERS)						
Input Threshold						See Figure 39 and Table 2
High	V_{TH}			100	mV	
Low	V_{TL}	-100			mV	
Differential Input Voltage	$ V_{ID} $	100			mV	See Figure 39 and Table 2
Input Common-Mode Voltage	V_{IC}	$0.5 V_{ID} $		$2.4 - 0.5 V_{ID} $	V	See Figure 39 and Table 2
Input Current, High and Low	I_{IH}, I_{IL}	-5		+5	μA	One $D_{INx\pm} = 2.4\text{ V or }0\text{ V}$, another $D_{INx\pm} = 1.2\text{ V}$, $V_{DDx} = 1.8\text{ V or }0\text{ V}$, and $V_{IOx} = 3.3\text{ V or }0\text{ V}$
Differential Input Capacitance ¹	$C_{INx\pm}$		1.7		pF	One $D_{INx\pm} = 0.4 \sin(30 \times 10^6 \pi t)\text{ V} + 0.5\text{ V}$ and another $D_{INx\pm} = 1.2\text{ V}$ ²
LOGIC INPUTS						
Input High Voltage	V_{INH}	$0.65 V_{DDx}$			V	$V_{DDx} = V_{DD1}$ for $\overline{\text{REFRESH}}_1$, $V_{DDx} = V_{DD2}$ for $\overline{\text{REFRESH}}_2$
Input Low Voltage	V_{INL}			$0.35 V_{DDx}$	V	
Input-Current High	$ I_{INH} $			1	μA	$\overline{\text{REFRESH}}_x = V_{DDx}$
				25	μA	$\overline{\text{REFRESH}}_x = 1.9\text{ V}$, $V_{DDx} = 0\text{ V}$
Input-Current Low	$ I_{INL} $			16	μA	$\overline{\text{REFRESH}}_x = 0\text{ V}$
OUTPUTS (DRIVERS)						
Differential Output Voltage	$ V_{OD} $	250	310	450	mV	See Figure 37 and Figure 38, load resistance (R_L) = 100 Ω
V_{OD} Magnitude Change	$\Delta V_{OD} $			50	mV	See Figure 37 and Figure 38, $R_L = 100\ \Omega$
Offset Voltage	V_{OS}	1.125	1.17	1.375	V	See Figure 37, $R_L = 100\ \Omega$
V_{OS} Magnitude Change	ΔV_{OS}			50	mV	See Figure 37, $R_L = 100\ \Omega$
V_{OS} , Peak-to-Peak ¹	$V_{OS(PP)}$			150	mV	See Figure 37, $R_L = 100\ \Omega$
Output Short-Circuit Current	I_{OS}			-20	mA	$D_{OUTx\pm} = 0\text{ V}$
				12	mA	$ V_{OD} = 0\text{ V}$
Differential Output Capacitance ¹	$C_{OUTx\pm}$		5		pF	One $D_{OUTx\pm} = 0.4 \sin(30 \times 10^6 \pi t)\text{ V} + 0.5\text{ V}$, another $D_{OUTx\pm} = 1.2\text{ V}$, and V_{DD1} or $V_{DD2} = 0\text{ V}$
ADN4622 SUPPLY CURRENT						
Supply Current Side 1	I_{DD1}		116	135	mA	Frequency (f) = 1.25 GHz, $R_L = 100\ \Omega$
			102	125		$f = 1.25\text{ GHz}$, $R_L = 100\ \Omega$, $\overline{\text{REFRESH}}_1 = V_{DD1}$
Supply Current Side 2	I_{DD2}		113	133	mA	$f = 1.25\text{ GHz}$, $R_L = 100\ \Omega$
			99	121	mA	$f = 1.25\text{ GHz}$, $R_L = 100\ \Omega$, $\overline{\text{REFRESH}}_2 = V_{DD2}$
V_{IO1} or V_{IO2} Supply	I_{IO1} or I_{IO2}		11	14	mA	$f = 1.25\text{ GHz}$
ADN4624 SUPPLY CURRENT						
Supply Current Side 1	I_{DD1}		140	175	mA	$f = 1.25\text{ GHz}$
Supply Current Side 2	I_{DD2}		115	140	mA	$f = 1.25\text{ GHz}$, $R_L = 100\ \Omega$
			95	135	mA	$f = 1.25\text{ GHz}$, $R_L = 100\ \Omega$, $\overline{\text{REFRESH}}_2 = V_{DD2}$
COMMON-MODE TRANSIENT IMMUNITY ³	$ CM $	40	100		kV/ μs	Common-mode voltage (V_{CM}) = 1000 V, transient magnitude = 800 V

¹ These specifications are guaranteed by design and characterization.

² t denotes time.

³ $|CM|$ is the maximum common-mode voltage slew rate that can be sustained while maintaining any D_{OUTx+} or D_{OUTx-} pin in the same state as the corresponding D_{INx+} or D_{INx-} pin (no change in output) or producing the expected transition on any D_{OUTx+} or D_{OUTx-} pin if the applied common-mode transient edge is coincident with a data transition on the corresponding D_{INx+} or D_{INx-} pin. The common-mode voltage slew rates apply to both rising and falling common-mode voltage edges.

SPECIFICATIONS

RECEIVER INPUT THRESHOLD TEST VOLTAGES

Table 2. Test Voltages for Receiver Operation

Applied Voltages		Input Voltage, Differential, V_{ID} (V)	Input Voltage, Common-Mode, V_{IC} (V)	Driver Output, Differential V_{OD} (mV)
D_{INx+} (V)	D_{INx-} (V)			
1.25	1.15	0.1	1.2	>250
1.15	1.25	-0.1	+1.2	<-250
2.4	2.3	0.1	2.35	>250
2.3	2.4	-0.1	+2.35	<-250
0.1	0	0.1	0.05	>250
0	0.1	-0.1	+0.05	<-250
1.5	0.9	0.6	1.2	>250
0.9	1.5	-0.6	+1.2	<-250
2.4	1.8	0.6	2.1	>250
1.8	2.4	-0.6	+2.1	<-250
0.6	0	0.6	0.3	>250
0	0.6	-0.6	+0.3	<-250

TIMING SPECIFICATIONS

For all minimum and maximum specifications, $V_{DD1} = V_{DD2} = 1.7$ V to 1.9 V and $T_A = -40^\circ\text{C}$ to $+125^\circ\text{C}$, unless otherwise noted. For all typical specifications, $V_{DD1} = V_{DD2} = 1.8$ V and $T_A = 25^\circ\text{C}$. For all specifications, $\overline{\text{REFRESH}}_1 = V_{DD1}$ and $\overline{\text{REFRESH}}_2 = V_{DD2}$, unless otherwise noted.

Table 3. Timing Specifications

Parameter	Symbol	Min	Typ	Max ¹	Unit	Test Conditions/Comments
PROPAGATION DELAY	t_{PLH}, t_{PHL}		2.15	2.8	ns	See Figure 40, from any D_{INx+} and D_{INx-} to D_{OUTx+} and D_{OUTx-}
SKEW						See Figure 40, across all D_{OUTx+} and D_{OUTx-}
Duty Cycle ²	$t_{SK(D)}$		2	16	ps	ADN4622 SOIC_W_FP package
Channel to Channel ³	$t_{SK(CH)}$		40	120	ps	ADN4624 SOIC_W_FP package
			38	92	ps	ADN4622 LFCSP package
			40	114	ps	ADN4624 LFCSP package
			29	67	ps	ADN4622 Channel 1 to Channel 2, or Channel 3 to Channel 4 only
Part to Part ⁴	$t_{SK(PP)}$		150	300	ps	
JITTER ⁵						See Figure 40, for any D_{OUTx+} and D_{OUTx-}
Random Jitter, RMS ⁶ (1σ)	$t_{RJ(RMS)}$		0.82	1.44	ps rms	1.25 GHz clock input
Deterministic Jitter, Peak-to-Peak ^{6, 7}	$t_{DJ(PP)}$		28	54	ps	2.5 Gbps, $2^{23} - 1$ pseudorandom bit stream (PRBS)
Total Jitter, Peak-to-Peak, at Bit Error Rate (BER) 1×10^{-12}	$t_{TJ(PP)}$		40	70	ps	1.25 GHz/2.5 Gbps, $2^{23} - 1$ PRBS ⁸
With Crosstalk			50		ps	1.25 GHz/2.5 Gbps, $2^{23} - 1$ PRBS all channels ⁹
With Crosstalk and Refresh			55		ps	1.25 GHz/2.5 Gbps, $2^{23} - 1$ PRBS all channels, $\overline{\text{REFRESH}}_1 = \text{GND}_1$, $\overline{\text{REFRESH}}_2 = \text{GND}_2$ ⁸
Additive Phase Jitter	t_{ADDJ}					
SOIC_W_FP Package			225		fs rms	100 Hz to 100 kHz, output frequency (f_{OUT}) = 10 MHz ⁹
			270		fs rms	100 Hz to 100 kHz, $f_{OUT} = 10$ MHz, $\overline{\text{REFRESH}}_1 = \text{GND}_1$, $\overline{\text{REFRESH}}_2 = \text{GND}_2$ ⁹
			85		fs rms	12 kHz to 20 MHz, $f_{OUT} = 1.25$ GHz ¹⁰
			200		fs rms	12 kHz to 20 MHz, $f_{OUT} = 1.25$ GHz, $\overline{\text{REFRESH}}_1 = \text{GND}_1$, $\overline{\text{REFRESH}}_2 = \text{GND}_2$ ¹⁰
LFCSP Package			152		fs rms	100 Hz to 100 kHz, output frequency (f_{OUT}) = 10 MHz ⁹

SPECIFICATIONS

Table 3. Timing Specifications (Continued)

Parameter	Symbol	Min	Typ	Max ¹	Unit	Test Conditions/Comments
			182		fs rms	100 Hz to 100 kHz, $f_{OUT} = 10$ MHz, $\overline{REFRESH}_1 = GND_1$, $\overline{REFRESH}_2 = GND_2$ ⁹
			152		fs rms	12 kHz to 20 MHz, $f_{OUT} = 1.25$ GHz ¹⁰
			348		fs rms	12 kHz to 20 MHz, $f_{OUT} = 1.25$ GHz, $\overline{REFRESH}_1 = GND_1$, $\overline{REFRESH}_2 = GND_2$ ¹⁰
RISE AND FALL TIME	t_R, t_F		180		ps	See Figure 40, 1.25 GHz clock input, any D_{OUTx+} and D_{OUTx-} , 20% to 80%, $R_L = 100 \Omega$, load capacitance (C_L) = 5 pF
MAXIMUM DATA RATE		2.5			Gbps	

¹ These specifications are guaranteed by design and characterization.

² Duty cycle or pulse skew is the magnitude of the maximum difference between t_{PLH} and t_{PHL} for any Channel x of a device (where x = 1, 2, 3, or 4), that is, $|t_{PLHx} - t_{PHLx}|$.

³ Channel to channel or output skew is the difference between the largest and smallest values of t_{PLHx} within a device or the difference between the largest and smallest values of t_{PHLx} within a device, whichever of the two is greater.

⁴ Part to part output skew is the difference between the largest and smallest values of t_{PLHx} across multiple devices or the difference between the largest and smallest values of t_{PHLx} across multiple devices, whichever of the two is greater.

⁵ Jitter parameters are guaranteed by design and characterization. Values do not include stimulus jitter. $V_{ID} = 400$ mV p-p, $V_{IC} = 1.2$ V, and $t_R / t_F < 0.05$ ns (20% to 80%).

⁶ This specification is measured over a population of ~3,000,000 edges.

⁷ Peak-to-peak jitter specifications include jitter due to pulse skew ($t_{SK(D)}$).

⁸ Using the following formula: $t_{TJ(PP)} = 14 \times t_{RJ(RMS)} + t_{DJ(PP)}$.

⁹ With an input phase jitter of 340 fs rms subtracted.

¹⁰ With an input phase jitter of 155 fs rms subtracted.

INSULATION AND SAFETY RELATED SPECIFICATIONS

For additional information, see www.analog.com/icouplersafety.

Table 4. Insulation and Safety Related Specifications

Parameter	Symbol	RN-28-1	Cp-32-32	Unit	Test Conditions/Comments
Rated Dielectric Insulation Voltage		5700	1500	V rms	1 minute duration
Minimum External Air Gap (Clearance) ^{1, 2}	L (I01)	8.3	1.27	mm	Measured from input terminals to output terminals, shortest distance through air
Minimum External Tracking (Creepage) ¹	L (I02)	8.3	1.27	mm	Measured from input terminals to output terminals, shortest distance path along body
Minimum Internal Gap (Internal Clearance)		29	29	μ m	Insulation distance through insulation
Tracking Resistance (Comparative Tracking Index)	CTI	>600	>600	V	Tested in accordance to IEC 60112
Material Group		I	I		Material Group per IEC 60664-1

¹ In accordance with IEC 62368-1 guidelines for the measurement of creepage and clearance distances for a pollution degree of 2 and altitudes ≤ 2000 m.

² Consideration must be given to pad layout to ensure the minimum required distance for clearance is maintained.

PACKAGE CHARACTERISTICS

Table 5. RN-28-1 Wide Body with Finer Pitch [SOIC_W_FP] Package and CP-32-32 Lead Frame Chip-Scale Package [LFCSP]

Parameter	Symbol	Min	Typ	Max	Unit	Test Conditions/Comments
Resistance (Input to Output) ¹	$R_{I,O}$		10^{13}		Ω	Voltage (input to output) ($V_{I,O}$) = 500 V DC
Capacitance (Input to Output) ¹	$C_{I,O}$		2.2		pF	$f = 1$ MHz
Input Capacitance ²	C_I		3.4		pF	

¹ The device is considered a 2-terminal device: Pin 1 through Pin 14 are shorted together (Pin 1 through Pin 16 for LFCSP), and Pin 15 through Pin 28 are shorted together (Pin 17 through Pin 32 for LFCSP).

SPECIFICATIONS

² Input capacitance is from any input data pin to ground.

REGULATORY INFORMATION

The ADN4622/ADN4624 RN-28-1 certification approvals are listed in [Table 6](#).

The ADN4622/ADN4624 CP-32-32 certification approvals are listed in [Table 7](#).

See [Table 16](#) and the [Insulation Lifetime](#) section for details regarding the recommended maximum working voltages for specific cross-isolation waveforms and insulation levels.

Table 6. RN-28-1 Wide-Body with Finer Pitch [SOIC_W_FP] Package

Regulatory Agency	Standard Certification/Approval	File
UL	UL 1577 ¹ Single protection, 5700 V rms	File E214100
CSA	IEC/EN/CSA 62368-1 Basic insulation, 830 V rms Reinforced insulation, 415 V rms IEC/CSA 61010-1 Basic insulation, 600 V rms Reinforced insulation, 300 V rms IEC/CSA 60601-1 Basic Insulation (1 MOPP), 519 V rms Reinforced insulation (2 MOPP), 50 V rms	File 205078
VDE	DIN EN IEC 60747-17 (VDE 0884-17) ² Reinforced insulation, 849 V peak	Certificate No. 40051926
CQC	CQC GB4943.1-2011 Basic insulation, 830 V rms Reinforced insulation, 415 V rms	Certificate No. CQC25001466588

¹ In accordance with UL 1577, each ADN4622/ADN4624 is proof tested by applying an insulation test voltage ≥ 6840 V rms for 1 sec.

² In accordance with DIN EN IEC 60747-17 (VDE 0884-17), each ADN4622/ADN4624 is proof tested by applying an insulation test voltage ≥ 1592 V peak for 1 sec (partial discharge detection limit = 5 pC).

Table 7. CP-32-32 Lead Frame Chip-Scale Package [LCFCSP]

Regulatory Agency	Standard Certification/Approval	File
UL	UL 1577 ¹ Single Protection, 1500 Vrms	File E214100
CSA	IEC/EN/CSA 62368-1 Basic Insulation, 255 V rms IEC/CSA 61010-1 Basic insulation, 251 V rms	File 205278
VDE	DIN EN IEC 60747-17 (VDE 0884-17) ² In accordance with DIN EN IEC 60747-17 (VDE 0884-17), each ADN4622/ADN4624 is proof tested by applying an insulation test voltage ≥ 1050 V peak for 1 sec (partial discharge detection limit = 5 pC). Reinforced insulation, 560 V peak	Certificate No. 40051926
CQC	CQC GB4943.1 Basic insulation, 250 V rms	File No. CQC25001472178

¹ In accordance with UL 1577, each ADN4622/ADN4624 is proof tested by applying an insulation test voltage ≥ 1800 V rms for 1 sec.

²

SPECIFICATIONS

DIN EN IEC 60747-17 (VDE 0884-17) INSULATION CHARACTERISTICS

This isolator is suitable for reinforced electrical isolation only within the safety limit data. Protective circuits ensure the maintenance of the safety data.

Table 8. ADN4622/ADN4624 VDE Insulation Characteristics

Description	Test Conditions/Comments	Symbol	RN-28-1	CP-32-32	Unit
Overvoltage category per IEC 60664-1					
≤ 150 V rms			I to IV	I to III	
≤ 300 V rms			I to IV	I to II	
≤ 600 V rms			I to IV	I to I	
Climatic Classification			40/125/21	40/125/21	
Pollution Degree per DIN VDE 0110, Table 1			2	2	
Maximum Repetitive Isolation Voltage		V _{IORM}	849	560	V peak
Maximum Working Isolation Voltage		V _{IOWM}	600	396	V rms
Input to Output Test Voltage, Method B1	V _{IORM} × 1.875 = V _{pd(m)} , 100% production test, t _{INI} = t _M = 1 sec, partial discharge < 5 pC	V _{pd(m)}	1592	1050	V peak
Input to Output Test Voltage, Method A					
After Environmental Tests Subgroup 1	V _{IORM} × 1.6 = V _{pd(m)} , t _{INI} = 60 sec, t _M = 10 sec, partial discharge < 5 pC	V _{pd(m)}	1358	896	V peak
After Input or Safety Test Subgroup 2 and Subgroup 3	V _{IORM} × 1.2 = V _{pd(m)} , t _{INI} = 60 sec, t _M = 10 sec, partial discharge < 5 pC	V _{pd(m)}	1019	672	V peak
Maximum Transient Isolation Voltage	V _{TEST} = 1.2 × V _{IOTM} , t = 1s (100% production)	V _{IOTM}	8000	2500	V peak
Maximum Impulse Voltage	Surge voltage in air, waveform per IEC 61000-4-5	V _{IMP}	8000	2500	V peak
Maximum Surge Isolation Voltage	V _{TEST} ≥ 1.3 × V _{IMP} (sample test), tested in oil, waveform per IEC 61000-4-5	V _{IOSM}	10000	10000	V peak
Safety Limiting Values	Maximum value allowed in the event of a failure (see Figure 4)				
Maximum Junction Temperature		T _S	150	150	°C
Total Power Dissipation at 25°C		P _S	2.74	4.12	W
Insulation Resistance at T _S	V _{IO} = 500 V	R _S	>10 ⁹	>10 ⁹	Ω

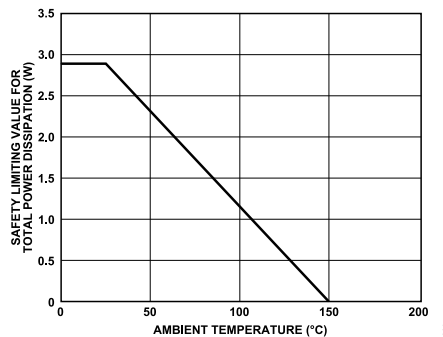

Figure 3. Thermal Derating Curve for RN-28-1, Dependence of Safety Limiting Values with Ambient Temperature per DIN EN IEC 60747-17 (VDE 0884-17), SOIC_W_FP

SPECIFICATIONS

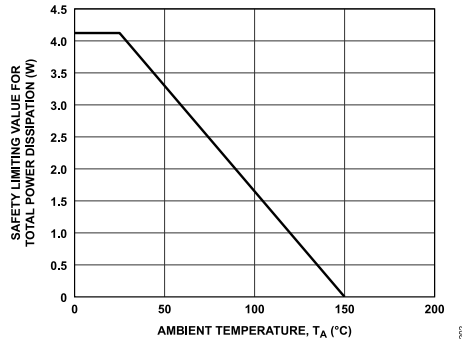

Figure 4. Thermal Derating Curve for CP-32-32, Dependence of Safety Limiting Values with Ambient Temperature per DIN EN IEC 60747-17 (VDE 0884-17)

RECOMMENDED OPERATING CONDITIONS

Table 9. Recommended Operating Conditions

Parameter	Symbol	Rating
Operating Temperature	T_A	-40°C to +125°C
V_{DDx} Supply Voltage Side 1 or Side 2	V_{DD1}, V_{DD2}	1.7 V to 1.9 V
V_{IOx} Supply Voltage Side 1 or Side 2	V_{IO1}, V_{IO2}	3 V to 3.6 V

ABSOLUTE MAXIMUM RATINGS

Table 10. Absolute Maximum Ratings

Parameter	Rating
V_{DD1} to GND_1 , V_{DD2} to GND_2	-0.3 V to +2 V
V_{IO1} to GND_1 , V_{IO2} to GND_2	-0.3 V to +4 V
Input Voltage $REFRESH_1$ to GND_1 , $REFRESH_2$ to GND_2	-0.3 V to +2 V
Input Voltage (D_{INx+} , D_{INx-}) to GND_x on the Same Side	-0.3 V to +4 V
Output Voltage (D_{OUTx+} , D_{OUTx-}) to GND_x on the Same Side	-0.3 V to +2 V
Short-Circuit Duration (D_{OUTx+} , D_{OUTx-}) to GND_x on the Same Side	Continuous
Operating Temperature Range	-40°C to +125°C
Storage Temperature Range	-65°C to +150°C
Junction Temperature (T_J Maximum)	150°C
Power Dissipation	$(T_J \text{ maximum} - T_A)/\theta_{JA}$

Stresses at or above those listed under Absolute Maximum Ratings may cause permanent damage to the product. This is a stress rating only; functional operation of the product at these or any other conditions above those indicated in the operational section of this specification is not implied. Operation beyond the maximum operating conditions for extended periods may affect product reliability.

MAXIMUM CONTINUOUS WORKING VOLTAGE

Table 11. Maximum Continuous Working Voltage

Parameter	Max	Unit	Applicable Certification
AC Voltage			
Bipolar Waveform		V peak	Reinforced insulation as per IEC 60747-17 (VDE 0884-17) ¹
CP-32-32	560		
RN-28-1	849		

¹ Refers to continuous voltage magnitude imposed across the isolation barrier. See the [Insulation Lifetime](#) section for more details.

THERMAL RESISTANCE

Thermal performance is directly linked to PCB design and operation environment. Close attention to PCB thermal design is required.

θ_{JA} is the natural convection junction to ambient thermal resistance measured in a one cubic foot sealed enclosure.

Table 12. Thermal Resistance

Package Type ¹	θ_{JA}	Unit
RN-28-1	43.45	°C/W
CP-32-32	30.3	°C/W

¹ Test Condition 1: thermal impedance simulated with 4-layer standard JEDEC PCB.

ELECTROSTATIC DISCHARGE (ESD) RATINGS

The following ESD information is provided for handling of ESD-sensitive devices in an ESD protected area only.

Human body model (HBM) per ANSI/ESDA/JEDEC JS-001.

International electrotechnical commission (IEC) electromagnetic compatibility: Part 4-2 (IEC) per IEC 61000-4-2.

ESD Ratings for ADN4622/ADN4624

Table 13. ADN4622/ADN4624, 28-Lead SOIC_W_FP

ESD Model	Withstand Threshold (V)	Class
HBM ¹	±4000	3A
IEC ²	±8000 (contact discharge)	Level 4

¹ All pins to respective GND_x , 1.5 k Ω , 100 pF.

² LVDS pins to isolated GND_x across isolation barrier.

Table 14. ADN4622/ADN4624, 32-Lead LFCSP

ESD Model	Withstand Threshold (V)	Class
HBM ¹	±4000	3A
IEC ²	±2000 (contact discharge)	Level 1

¹ All pins to respective GND_x , 1.5 k Ω , 100 pF.

² LVDS pins to isolated GND_x across isolation barrier.

ESD CAUTION



ESD (electrostatic discharge) sensitive device. Charged devices and circuit boards can discharge without detection. Although this product features patented or proprietary protection circuitry, damage may occur on devices subjected to high energy ESD. Therefore, proper ESD precautions should be taken to avoid performance degradation or loss of functionality.

PIN CONFIGURATIONS AND FUNCTION DESCRIPTIONS

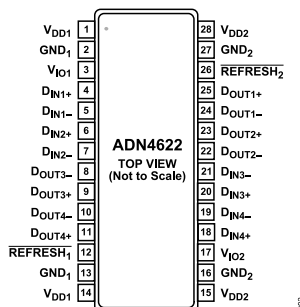
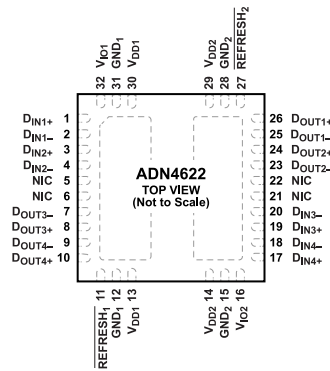

Figure 5. ADN4622 SOIC_W_FP Pin Configuration

Table 15. ADN4622 SOIC_W_FP Pin Function Descriptions

Pin No.	Mnemonic	Description
1, 14	V _{DD1}	1.8 V Power Supply for Side 1. Connect both pins externally and bypass to the adjacent GND ₁ pins with 0.1 μF capacitors.
2, 13	GND ₁	Ground, Side 1.
3	V _{IO1}	3.3 V Input and Output Power Supply for Side 1. Bypass to the adjacent GND ₁ pin with a 0.1 μF capacitor.
4	D _{IN1+}	Noninverted Differential Input 1.
5	D _{IN1-}	Inverted Differential Input 1.
6	D _{IN2+}	Noninverted Differential Input 2.
7	D _{IN2-}	Inverted Differential Input 2.
8	D _{OUT3-}	Inverted Differential Output 3.
9	D _{OUT3+}	Noninverted Differential Output 3.
10	D _{OUT4-}	Inverted Differential Output 4.
11	D _{OUT4+}	Noninverted Differential Output 4.
12	REFRESH ₁	Active-Low Enable for Side 1 Refresh Function. Short to GND ₁ for normal operation with refresh enabled, or short to V _{DD1} for lower power, lower jitter, and quieter operation with refresh disabled.
15, 28	V _{DD2}	1.8 V Power Supply for Side 2. Connect both pins externally and bypass to the adjacent GND ₂ pins with 0.1 μF capacitors.
16, 27	GND ₂	Ground, Side 2.
17	V _{IO2}	3.3 V Input and Output Power Supply for Side 2. Bypass to the adjacent GND ₂ pin with a 0.1 μF capacitor.
18	D _{IN4+}	Noninverted Differential Input 4.
19	D _{IN4-}	Inverted Differential Input 4.
20	D _{IN3+}	Noninverted Differential Input 3.
21	D _{IN3-}	Inverted Differential Input 3.
22	D _{OUT2-}	Inverted Differential Output 2.
23	D _{OUT2+}	Noninverted Differential Output 2.
24	D _{OUT1-}	Inverted Differential Output 1.
25	D _{OUT1+}	Noninverted Differential Output 1.
26	REFRESH ₂	Active-Low Enable for Side 2 Refresh Function. Short to GND ₂ for normal operation with refresh enabled, or short to V _{DD2} for lower power, lower jitter, and quieter operation with refresh disabled.

PIN CONFIGURATIONS AND FUNCTION DESCRIPTIONS



- NOTES**
1. NIC = NOT INTERNALLY CONNECTED.
 2. CONNECT THE SIDE 1 EPAD TO THE SAME PCB GROUND AS THE GND₁ PINS. CONNECT THE SIDE 2 EPAD TO THE SAME PCB GROUND AS THE GND₂ PINS.

Figure 6. ADN4622 LFCSP Pin Configuration

Table 16. ADN4622 LFCSP Pin Function Descriptions

Pin No.	Mnemonic	Description
1	D _{IN1+}	Noninverted Differential Input 1.
2	D _{IN1-}	Inverted Differential Input 1.
3	D _{IN2+}	Noninverted Differential Input 2.
4	D _{IN2-}	Inverted Differential Input 2.
5, 6, 21, 22	NIC	Not Internally Connected. These pins are not internally connected.
7	D _{OUT3-}	Inverted Differential Output 3.
8	D _{OUT3+}	Noninverted Differential Output 3.
9	D _{OUT4-}	Inverted Differential Output 4.
10	D _{OUT4+}	Noninverted Differential Output 4.
11	REFRESH ₁	Active-Low Enable for Side 1 Refresh Function. Short to GND ₁ for normal operation with refresh enabled, or short to V _{DD1} for lower power, lower jitter, and quieter operation with refresh disabled.
12, 31	GND ₁	Ground, Side 1.
13, 30	V _{DD1}	1.8 V Power Supply for Side 1. Connect both pins externally and bypass to the adjacent GND ₁ pins with 0.1 μF capacitors.
14, 29	V _{DD2}	1.8 V Power Supply for Side 2. Connect both pins externally and bypass to the adjacent GND ₂ pins with 0.1 μF capacitors.
15, 28	GND ₂	Ground, Side 2.
16	V _{IO2}	3.3 V Input and Output Power Supply for Side 2. Bypass to the adjacent GND ₂ pin with a 0.1 μF capacitor.
17	D _{IN4+}	Noninverted Differential Input 4.
18	D _{IN4-}	Inverted Differential Input 4.
19	D _{IN3+}	Noninverted Differential Input 3.
20	D _{IN3-}	Inverted Differential Input 3.
23	D _{OUT2-}	Inverted Differential Output 2.
24	D _{OUT2+}	Noninverted Differential Output 2.
25	D _{OUT1-}	Inverted Differential Output 1.
26	D _{OUT1+}	Noninverted Differential Output 1.
27	REFRESH ₂	Active-Low Enable for Side 2 Refresh Function. Short to GND ₂ for normal operation with refresh enabled, or short to V _{DD2} for lower power, lower jitter, and quieter operation with refresh disabled.
32	V _{IO1}	3.3 V Input and Output Power Supply for Side 1. Bypass to the adjacent GND ₁ pin with a 0.1 μF capacitor.
	EPAD	Exposed Pad. Connect the Side 1 EPAD to the same PCB ground as the GND ₁ pins. Connect the Side 2 EPAD to the same PCB ground as the GND ₂ pins.

PIN CONFIGURATIONS AND FUNCTION DESCRIPTIONS

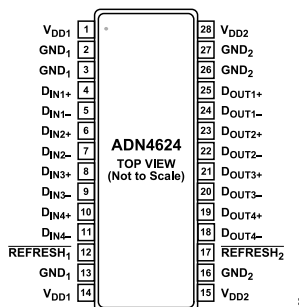

Figure 7. ADN4624 SOIC_W_FP Pin Configuration

Table 17. ADN4624 SOIC_W_FP Pin Function Descriptions

Pin No.	Mnemonic	Description
1, 14	V _{DD1}	1.8 V Power Supply for Side 1. Connect both pins externally and bypass to the adjacent GND ₁ pins with 0.1 μF capacitors.
2, 3, 13	GND ₁	Ground, Side 1.
4	D _{IN1+}	Noninverted Differential Input 1.
5	D _{IN1-}	Inverted Differential Input 1.
6	D _{IN2+}	Noninverted Differential Input 2.
7	D _{IN2-}	Inverted Differential Input 2.
8	D _{IN3+}	Noninverted Differential Input 3.
9	D _{IN3-}	Inverted Differential Input 3.
10	D _{IN4+}	Noninverted Differential Input 4.
11	D _{IN4-}	Inverted Differential Input 4.
12	$\overline{\text{REFRESH}}_1$	Active-Low Enable for Side 1 Refresh Function. Short to GND ₁ for normal operation with refresh enabled, or short to V _{DD1} for lower power, lower jitter, and quieter operation with refresh disabled.
15, 28	V _{DD2}	1.8 V Power Supply for Side 2. Connect both pins externally and bypass to the adjacent GND ₂ pins with 0.1 μF capacitors.
16, 26, 27	GND ₂	Ground, Side 2.
17	$\overline{\text{REFRESH}}_2$	Active-Low Enable for Side 2 Refresh Function. Short to GND ₂ for normal operation with refresh enabled, or short to V _{DD2} for lower power, lower jitter, and quieter operation with refresh disabled.
18	D _{OUT4-}	Inverted Differential Output 4.
19	D _{OUT4+}	Noninverted Differential Output 4.
20	D _{OUT3-}	Inverted Differential Output 3.
21	D _{OUT3+}	Noninverted Differential Output 3.
22	D _{OUT2-}	Inverted Differential Output 2.
23	D _{OUT2+}	Noninverted Differential Output 2.
24	D _{OUT1-}	Inverted Differential Output 1.
25	D _{OUT1+}	Noninverted Differential Output 1.

PIN CONFIGURATIONS AND FUNCTION DESCRIPTIONS

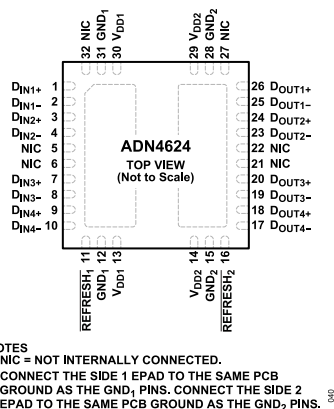

Figure 8. ADN4624 LFCSP Pin Configuration

Table 18. ADN4624 LFCSP Pin Function Descriptions

Pin No.	Mnemonic	Description
1	D _{IN1+}	Noninverted Differential Input 1.
2	D _{IN1-}	Inverted Differential Input 1.
3	D _{IN2+}	Noninverted Differential Input 2.
4	D _{IN2-}	Inverted Differential Input 2.
5, 6, 21, 22, 27, 32	NIC	Not Internally Connected. These pins are not internally connected.
7	D _{IN3+}	Noninverted Differential Input 3.
8	D _{IN3-}	Inverted Differential Input 3.
9	D _{IN4+}	Noninverted Differential Input 4.
10	D _{IN4-}	Inverted Differential Input 4.
11	REFRESH ₁	Active-Low Enable for Side 1 Refresh Function. Short to GND ₁ for normal operation with refresh enabled, or short to V _{DD1} for lower power, lower jitter, and quieter operation with refresh disabled.
12, 31	GND ₁	Ground, Side 1.
13, 30	V _{DD1}	1.8 V Power Supply for Side 1. Connect both pins externally and bypass to the adjacent GND ₁ pins with 0.1 μF capacitors.
14, 29	V _{DD2}	1.8 V Power Supply for Side 2. Connect both pins externally and bypass to the adjacent GND ₂ pins with 0.1 μF capacitors.
15, 28	GND ₂	Ground, Side 2.
16	REFRESH ₂	Active-Low Enable for Side 2 Refresh Function. Short to GND ₂ for normal operation with refresh enabled, or short to V _{DD2} for lower power, lower jitter, and quieter operation with refresh disabled.
17	D _{OUT4-}	Inverted Differential Output 4.
18	D _{OUT4+}	Noninverted Differential Output 4.
19	D _{OUT3-}	Inverted Differential Output 3.
20	D _{OUT3+}	Noninverted Differential Output 3.
23	D _{OUT2-}	Inverted Differential Output 2.
24	D _{OUT2+}	Noninverted Differential Output 2.
25	D _{OUT1-}	Inverted Differential Output 1.
26	D _{OUT1+}	Noninverted Differential Output 1.
	EPAD	Exposed Pad. Connect the Side 1 EPAD to the same PCB ground as the GND ₁ pins. Connect the Side 2 EPAD to the same PCB ground as the GND ₂ pins.

TYPICAL PERFORMANCE CHARACTERISTICS

$V_{DD1} = V_{DD2} = 1.8\text{ V}$, $T_A = 25^\circ\text{C}$, $\overline{\text{REFRESH}}_1 = \text{GND}_1$, $\overline{\text{REFRESH}}_2 = \text{GND}_2$, $R_L = 100\ \Omega$, 1.25 GHz clock input with $|V_{ID}| = 200\text{ mV}$, $V_{IC} = 1.2\text{ V}$, and t_R and $t_F < 0.05\text{ ns}$, unless otherwise noted.

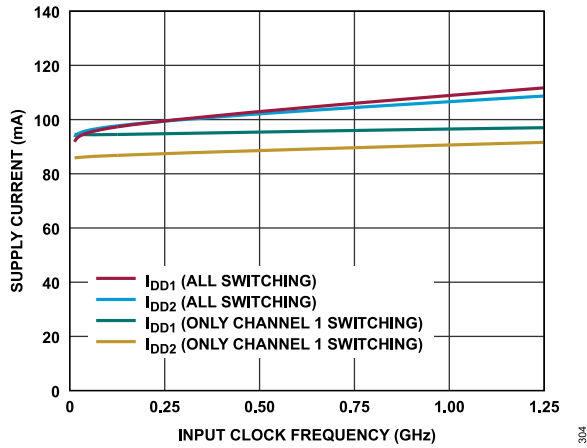

Figure 9. Supply Current vs. Input Clock Frequency for the ADN4622

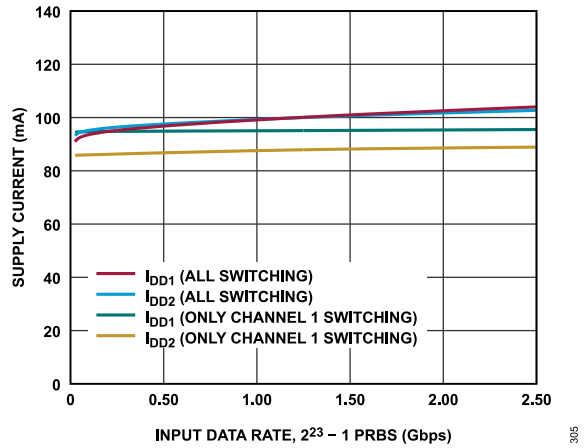

Figure 12. Supply Current vs. Input Data Rate, $2^{23} - 1$ PRBS for the ADN4622

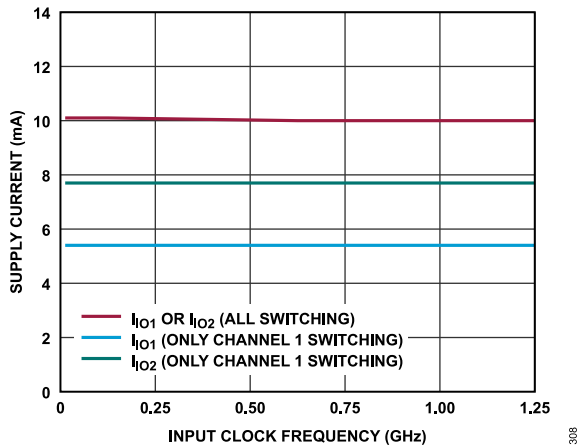

Figure 10. V_{I01} and V_{I02} Supply Current vs. Input Clock Frequency for the ADN4622

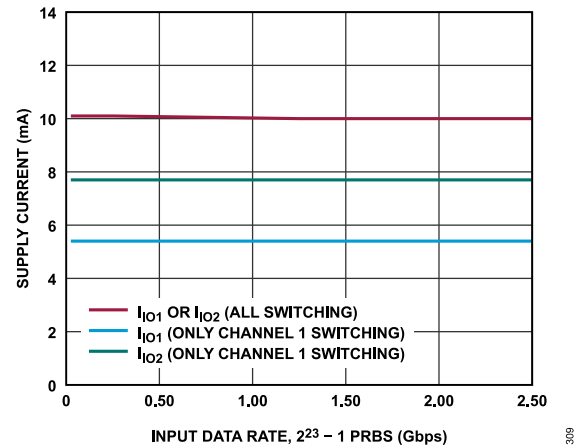

Figure 13. V_{I01} and V_{I02} Supply Current vs. Input Data Rate, $2^{23} - 1$ PRBS for the ADN4622

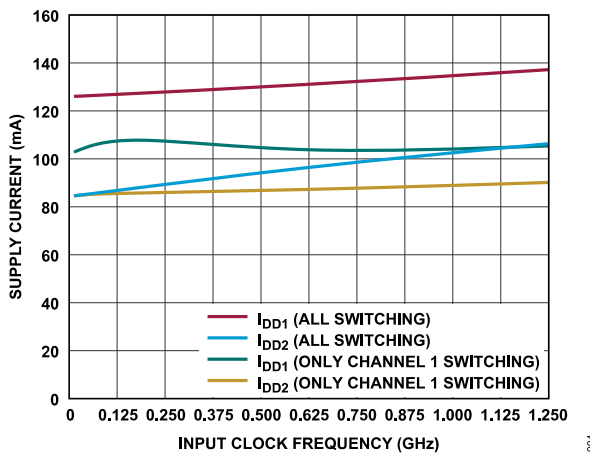

Figure 11. Supply Current vs. Input Clock Frequency for the ADN4624

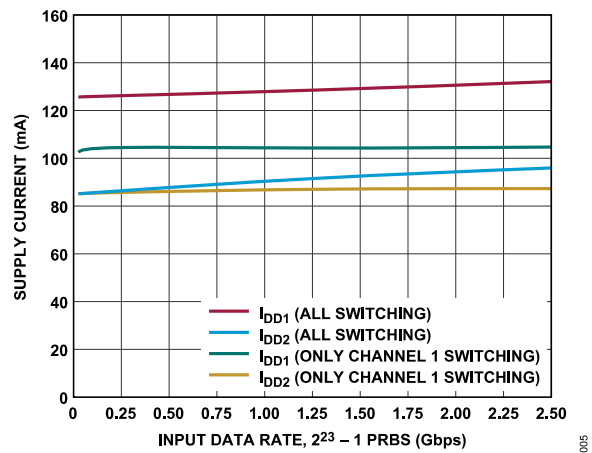

Figure 14. Supply Current vs. Input Data Rate, $2^{23} - 1$ PRBS for the ADN4624

TYPICAL PERFORMANCE CHARACTERISTICS

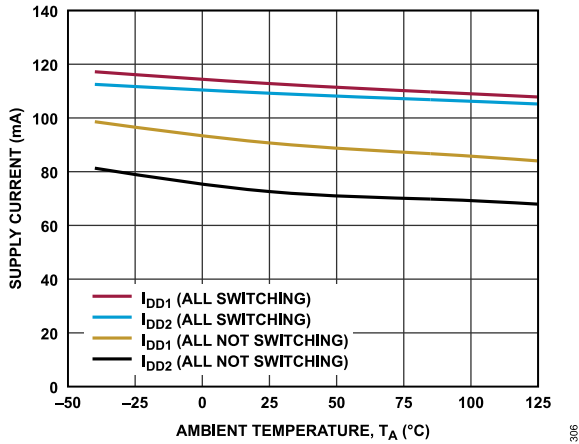

Figure 15. Supply Current vs. Ambient Temperature for the ADN4622

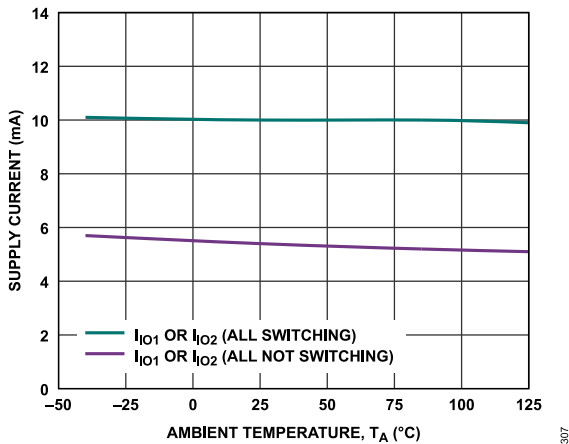

Figure 16. V_{I01} and V_{I02} Supply Current vs. Ambient Temperature for the ADN4622

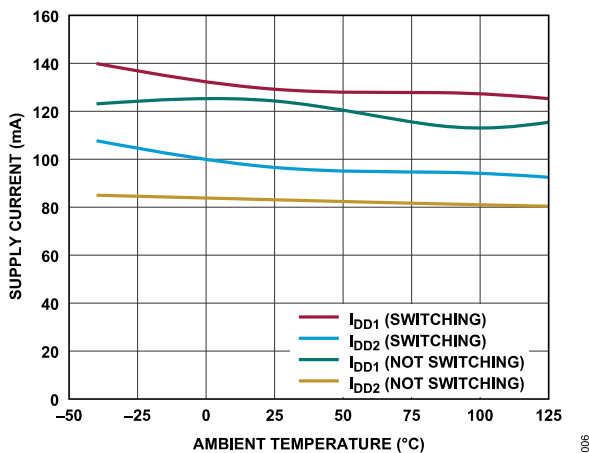

Figure 17. Supply Current vs. Ambient Temperature for the ADN4624

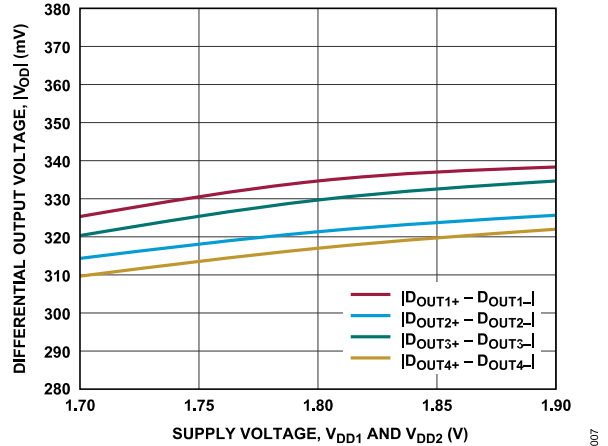

Figure 18. Differential Output Voltage, $|V_{OD}|$ vs. Supply Voltage, V_{DD1} and V_{DD2}

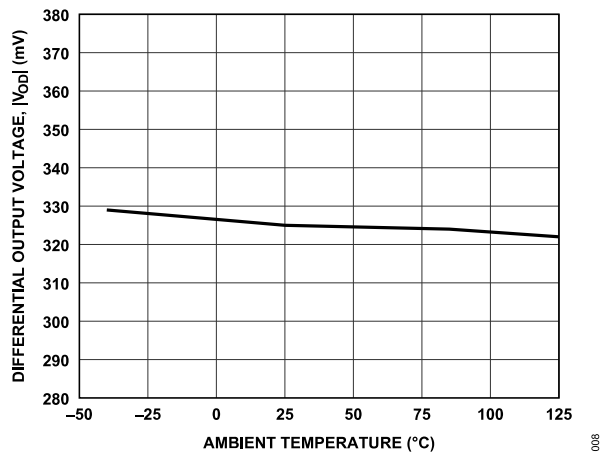

Figure 19. Differential Output Voltage, $|V_{OD}|$ vs. Ambient Temperature

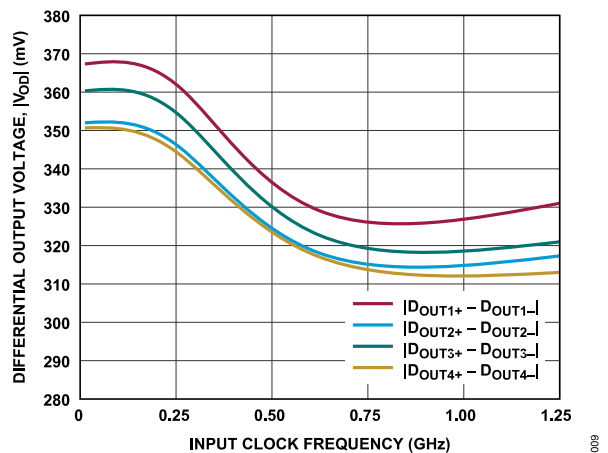

Figure 20. Differential Output Voltage, $|V_{OD}|$ vs. Input Clock Frequency

TYPICAL PERFORMANCE CHARACTERISTICS

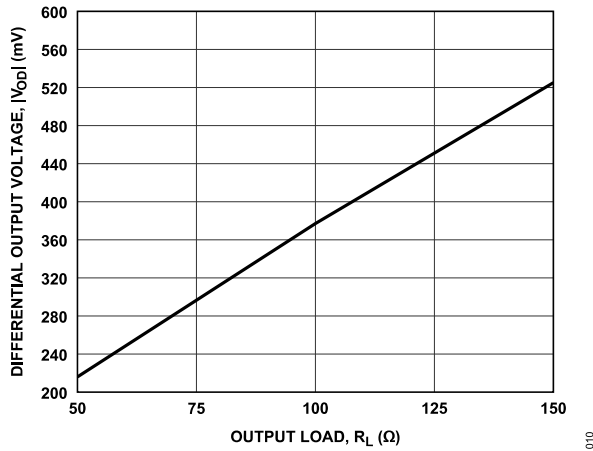

Figure 21. Differential Output Voltage, $|V_{OD}|$ vs. Output Load, R_L (DC Input)

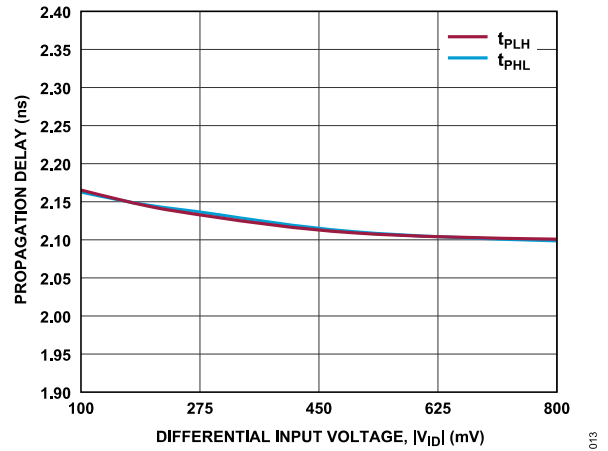

Figure 24. Propagation Delay vs. Differential Input Voltage, $|V_{ID}|$

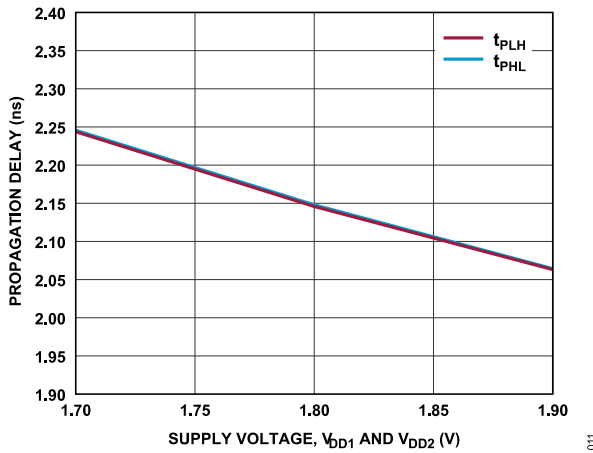

Figure 22. Propagation Delay vs. Supply Voltage, V_{DD1} and V_{DD2}

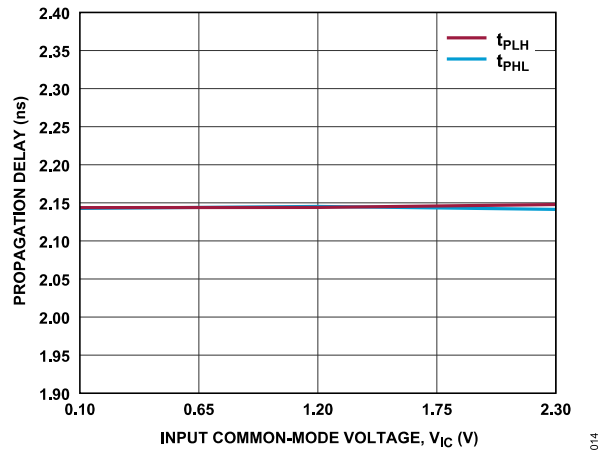

Figure 25. Propagation Delay vs. Input Common-Mode Voltage, V_{IC}

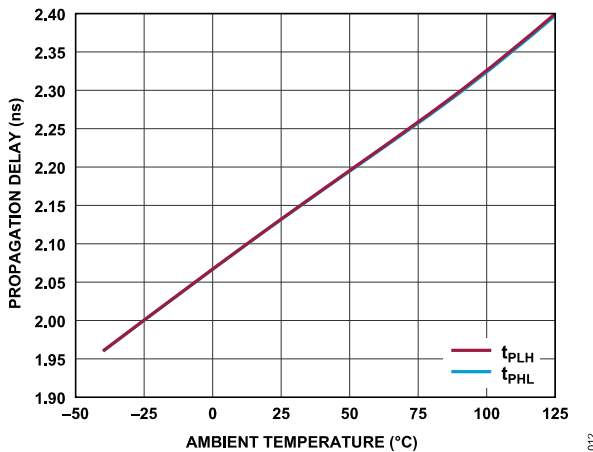

Figure 23. Propagation Delay vs. Ambient Temperature

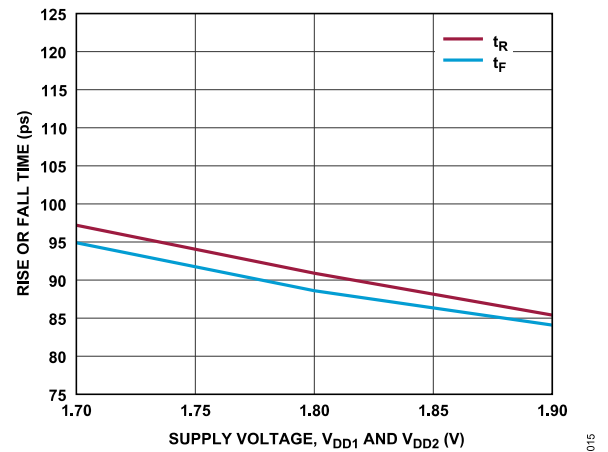

Figure 26. Rise or Fall Time vs. Supply Voltage, V_{DD1} and V_{DD2}

TYPICAL PERFORMANCE CHARACTERISTICS

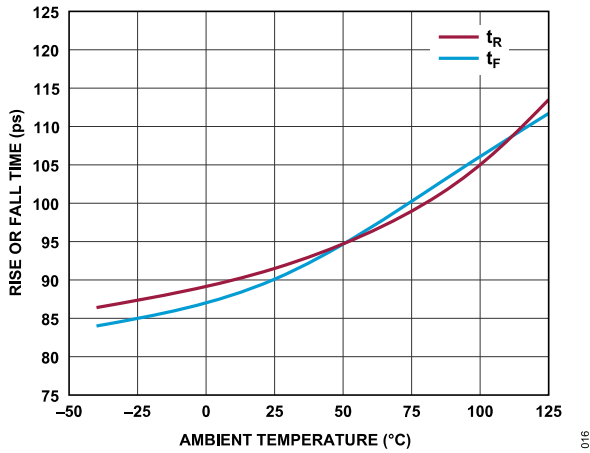

Figure 27. Rise or Fall Time vs. Ambient Temperature

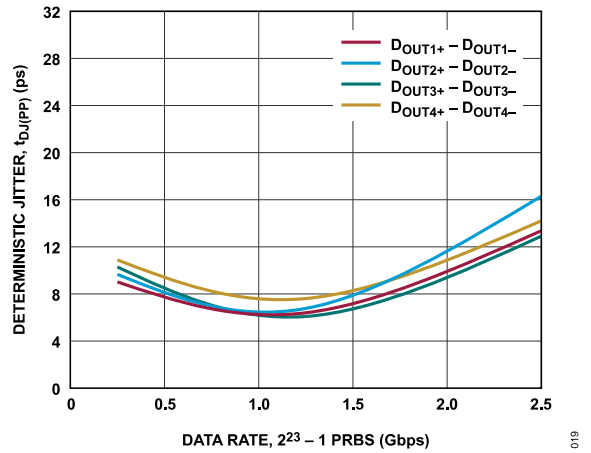

Figure 30. Deterministic Jitter, $t_{DJ(PP)}$ vs. Data Rate, $2^{23} - 1$ PRBS

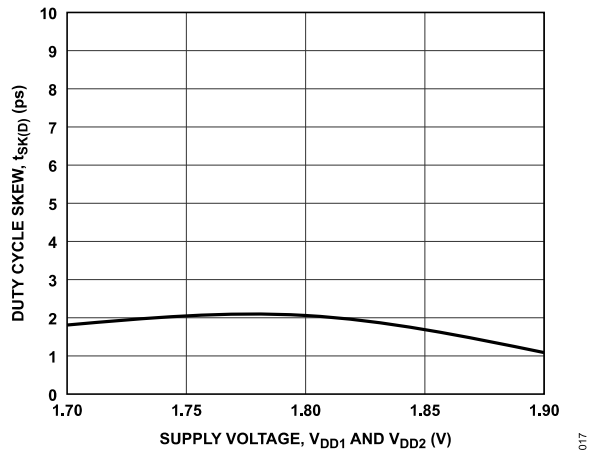

Figure 28. Duty Cycle Skew, $t_{SK(D)}$ vs. Supply Voltage, V_{DD1} and V_{DD2}

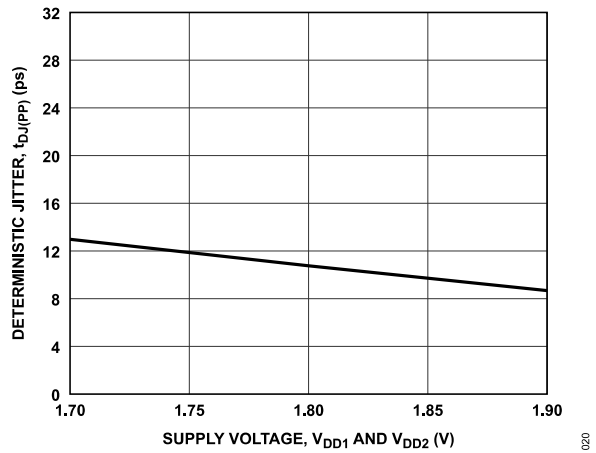

Figure 31. Deterministic Jitter, $t_{DJ(PP)}$ vs. Supply Voltage, V_{DD1} and V_{DD2}

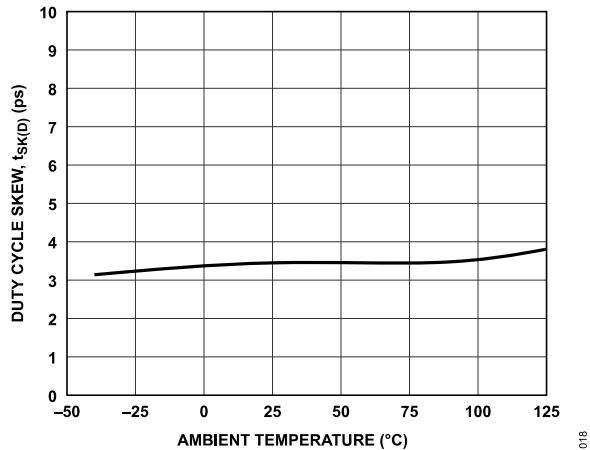

Figure 29. Duty Cycle Skew, $t_{SK(D)}$ vs. Ambient Temperature

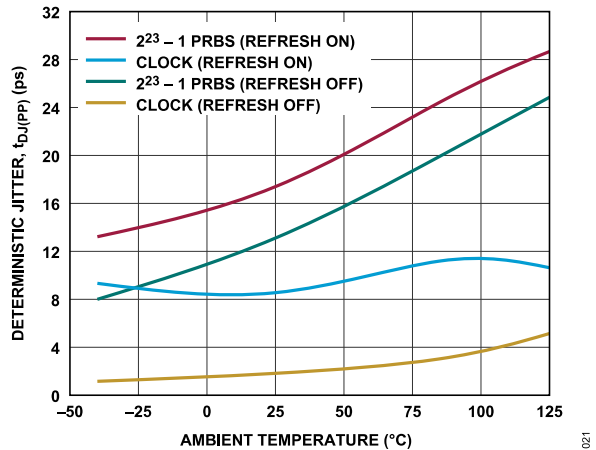

Figure 32. Deterministic Jitter, $t_{DJ(PP)}$ vs. Ambient Temperature

TYPICAL PERFORMANCE CHARACTERISTICS

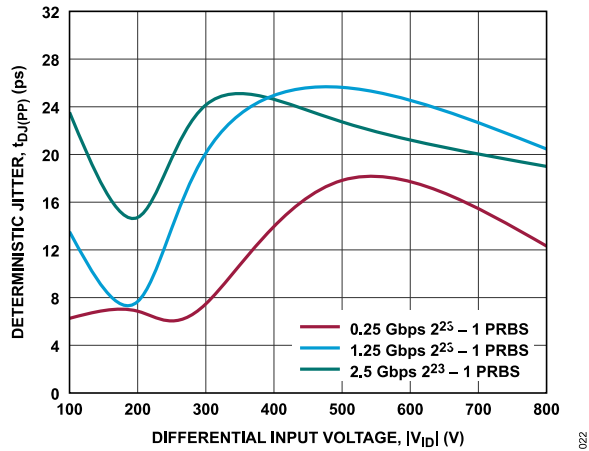

Figure 33. Deterministic Jitter, $t_{DJ(pp)}$ vs. Differential Input Voltage, $|V_{ID}|$

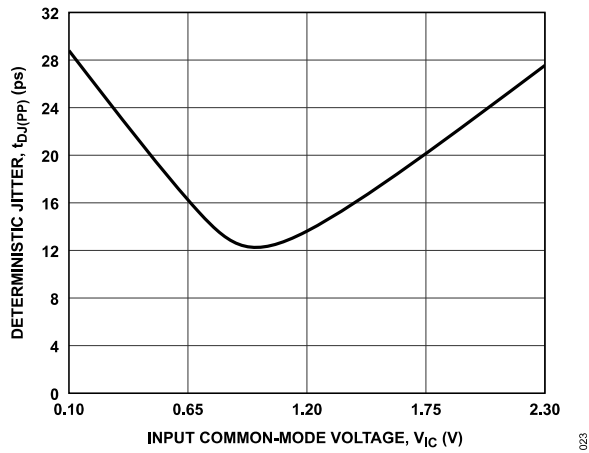

Figure 34. Deterministic Jitter, $t_{DJ(pp)}$ vs. Input Common-Mode Voltage, V_{IC}

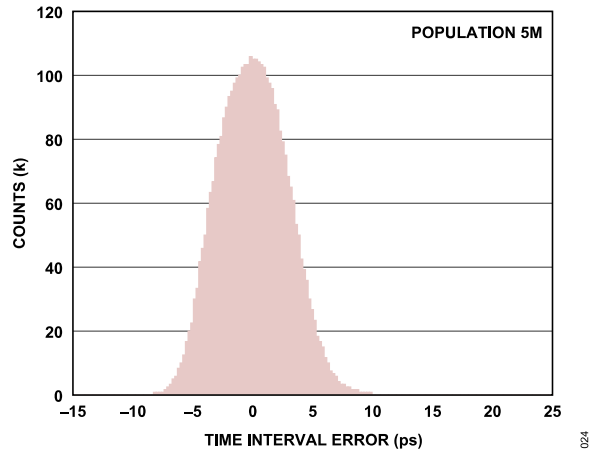

Figure 35. Time Interval Error (TIE) Histogram for $D_{OUT1\pm}$ at 1.25 GHz

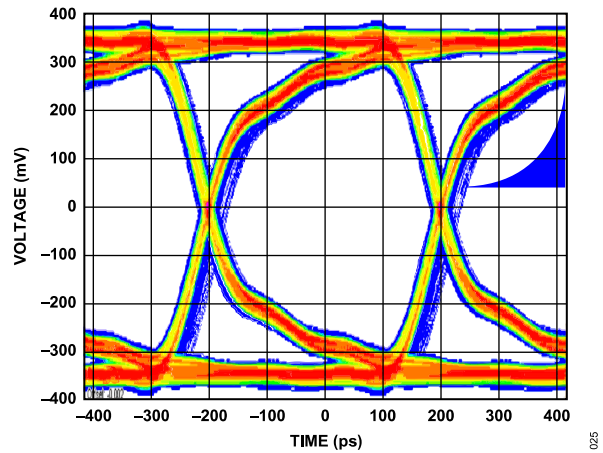

Figure 36. Eye Diagram for $D_{OUT1\pm}$ at 1.25 GHz

TEST CIRCUITS AND SWITCHING CHARACTERISTICS

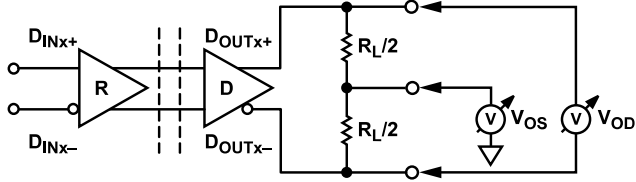
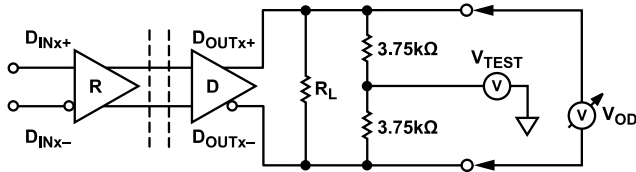
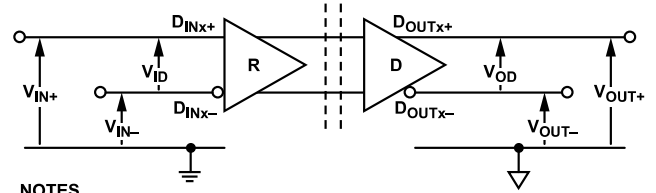

Figure 37. Driver Test Circuit



- NOTES
1. $V_{TEST} = 0V$ TO $2.4V$

Figure 38. Driver Test Circuit (Full Load Across Common-Mode Range)



- NOTES
1. $V_{ID} = V_{IN+} - V_{IN-}$
2. $V_{IC} = (V_{IN+} + V_{IN-})/2$
3. $V_{OD} = V_{OUT+} - V_{OUT-}$
4. $V_{OS} = (V_{OUT+} + V_{OUT-})/2$

Figure 39. Voltage Definitions

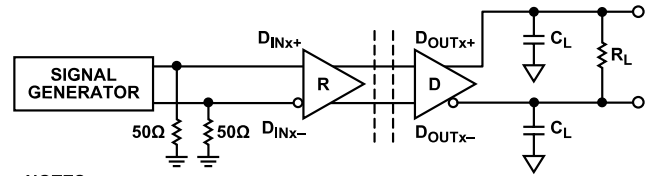

- NOTES
1. C_L INCLUDES PROBE AND JIG CAPACITANCE.

Figure 40. Timing Test Circuit

THEORY OF OPERATION

The ADN4622/ADN4624 are a high-speed differential signal isolators capable of switching up to 2.5 Gbps with signal levels compliant to TIA/EIA-644-A. The devices couple differential signals applied to the LVDS receiver inputs across the isolation barrier to the outputs on the other side and re-transmits the bit stream or clock as LVDS. This integration allows drop-in isolation of LVDS signal chains and isolation of other signals such as CML.

The LVDS receiver detects the differential voltage present across a termination resistor on an LVDS input. An integrated digital isolator transmits the input state across the isolation barrier, and an LVDS driver outputs the same state as the input.

When there is a positive differential voltage of ≥ 100 mV across a termination resistor between any D_{INx+} pin and a corresponding D_{INx-} pin, the corresponding D_{OUTx+} pin sources current. This current flows across the connected transmission line and termination at the receiver at the far end of the bus, while D_{OUTx-} sinks the return current. When there is a negative differential voltage of ≤ -100 mV across any $D_{INx\pm}$ pin, the corresponding D_{OUTx+} pin sinks current with the D_{OUTx-} pin sourcing the current. [Table 19](#) shows these input and output combinations.

The output drive current is between ± 2.5 mA and ± 4.5 mA (typically ± 3.1 mA), developing between ± 250 mV and ± 450 mV across a $100\ \Omega$ termination resistor (R_T). The received voltage is centered around 1.2 V. Because the differential voltage (V_{ID}) reverses polarity, the peak-to-peak voltage swing across R_T is twice the differential voltage magnitude ($|V_{ID}|$).

ISOLATION AND REFRESH

In response to any change in the input state detected by the integrated LVDS receiver, an encoder circuit sends narrow (~ 1 ns) pulses to a decoder circuit using integrated transformer coils. The decoder is bistable and is, therefore, either set or reset by the pulses that indicate input transitions. The decoder state determines the LVDS driver output state in normal operation, which reflects the isolated LVDS buffer input state.

For normal operation of the ADN4622/ADN4624, the active-low enable pins, $\overline{\text{REFRESH}}_1$ and $\overline{\text{REFRESH}}_2$, are shorted to GND_1 and GND_2 , respectively, to enable a refresh function. When enabled, this function means that in the absence of input transitions for more than approximately $1\ \mu\text{s}$, a periodic set of refresh pulses, indicative of the correct input state, ensures DC correctness at the output (including the fail-safe output state, if applicable).

On power-up, the output state can initially be in the incorrect DC state if there are no input transitions. The output state is corrected within $1\ \mu\text{s}$ by the refresh pulses.

If the decoder receives no internal pulses for more than approximately $1\ \mu\text{s}$, the device assumes that the input side is unpowered or nonfunctional, in which case, the output is set to a positive differential voltage (logic high).

For clocks, constant bit streams, or protocols with error correction, the refresh functionality may not be required. If $\overline{\text{REFRESH}}_1$ and $\overline{\text{REFRESH}}_2$ are shorted to VDD_1 and VDD_2 , respectively, the refresh functionality is disabled, allowing for lower power operation with no internal clock-like signals (potentially reducing conducted or radiated emissions). In this mode of operation, a new data transition at the input can be required to correct the output state, either after power-up or after a common-mode transient event beyond the guaranteed common-mode transient immunity specification.

TRUTH TABLE

The LVDS standard, TIA/EIA-644-A, defines normal receiver operation under two conditions: an input differential voltage of $\geq +100$ mV corresponding to one logic state, and a voltage of ≤ -100 mV for the other logic state. Between these thresholds, the standard LVDS receiver operation is undefined (the LVDS receiver can detect either state), as shown in [Table 19](#).

Table 19. Input and Output Operation

Input ($D_{INx\pm}$)			Output ($D_{OUTx\pm}$)		
Powered On	V_{ID} (mV)	Logic	Powered On	V_{OD} (mV)	Logic
Yes	≥ 100	High	Yes	≥ 250	High
Yes	≤ -100	Low	Yes	≤ -250	Low
Yes	$-100 < V_{ID} < +100$	Indeterminate	Yes	Indeterminate	Indeterminate
No	Don't care	Don't care	Yes	≥ 250	High

APPLICATIONS INFORMATION

PCB LAYOUT

The ADN4622/ADN4624 can operate with high-speed LVDS signals up to 1.25 GHz clock, or 2.5 Gbps nonreturn to zero (NRZ) data. When operating with such high frequencies, apply best practices for the LVDS trace layout and termination. Place a 100 Ω termination resistor as close as possible to the receiver, across the D_{INx+} and D_{INx-} pins.

Controlled impedance traces (100 Ω differential) are needed on LVDS signal lines for full signal integrity, reduced system jitter, and for minimizing electromagnetic interference (EMI) from the PCB. Trace widths, lateral distance within each pair, and distance to the ground plane underneath all must be chosen appropriately. Via fencing to the PCB ground between pairs is also a best practice to minimize crosstalk between adjacent pairs.

The ADN4624 has passed EN 55032 Class B emissions limits without extra considerations required for the isolator when operating with up to 2 Gbps PRBS data. When isolating at higher data rates or for high-speed clocks, specific PCB layout measures can be required to reduce dipole antenna effects from the isolation gap and provide sufficient margin below Class B emissions limits. The ADN4622 has passed EN 55032 Class B emissions limits when operating with up to 900 Mbps PRBS data, using a high-speed PCB design with an embedded PCB stitching capacitor (constructed by overlapping internal PCB Layer 2 and Layer 3 under the area of the isolator).

The best practice for high-speed PCB design avoids emissions from traces with high-speed LVDS signals. Special care is recommended for off board connections, where switching transients from high-speed LVDS signals (and clocks in particular) can conduct onto cabling, resulting in radiated emissions. Use common-mode chokes, ferrites, or other filters as appropriate at LVDS connectors and power supplies, as well as cable shield or PCB ground connections to earth or chassis.

The ADN4622/ADN4624 require appropriate decoupling of the V_{DDx} pins with 100 nF capacitors. Power supplies must also have appropriate filtering to avoid possible radiated emissions due to high-frequency switching noise.

APPLICATION EXAMPLES

High-speed LVDS interfaces for the analog front end (AFE), processor to processor serial communication, or video and imaging data can be isolated using the ADN4622/ADN4624 between components, between boards, or at a cable interface.

The ADN4622/ADN4624 provides the galvanic isolation required for robust external ports, and the low jitter and high drive strength of the device allow communication along short cable runs of a few meters. High common-mode immunity ensures communication integrity even in harsh, noisy environments, and isolation can protect against electromagnetic compatibility (EMC) transients up to ± 8 kV_{PEAK}, such as ESD, electrical fast transient (EFT), and surge.

Standard LVDS inputs and outputs allow simple integration into high-speed signal chains using field-programmable gate arrays (FPGAs), redrivers, or coupling networks to interface to CML and other physical layers.

Isolated AFE applications provide an example of the ADN4622/ADN4624 isolating an LVDS interface between components. The ADN4624 can isolate four channels simultaneously, which suits the isolation of high-bandwidth measurement data from analog-to-digital converters (ADCs) with parallel LVDS outputs, and the ADN4622 can isolate two LVDS channels in each direction, which suits the isolation of the ADCs relying on echoed clocks. Both can alternatively be used with serialization and deserialization (SERDES) applications using FPGAs to aggregate large arrays of CMOS inputs or outputs through the 2.5 Gbps isolation channels. The ADN4622/ADN4624 additive phase jitter is sufficiently low that it does not affect the ADC performance even when isolating the sample clock. In addition, implementing the galvanic isolation improves ADC performance by removing digital and power-supply noise from the FPGA and application-specific IC (ASIC) circuit.

PCB to PCB connections and even cable interfaces can leverage LVDS signaling for high bandwidth links with low-latency synchronous data transfer. Serialized Gigabit Ethernet connections can be isolated to robustly cascade Ethernet or multiprotocol switches for industrial controller communication modules. The ADN4622 with two LVDS channels in each direction can isolate the 1.25 Gbps transmit and receive signals for two ports at each Gigabit Ethernet switch. The propagation delay of just over a couple of nanoseconds provides the low latency needed for industrial automation and process control.

The ADN4624 can isolate a range of video and imaging protocols, including protocols that use CML rather than LVDS for the physical layer. One example is High-Definition Multimedia Interface (HDMI), where AC coupling and biasing and termination resistor networks are used, as shown in [Figure 41](#) to convert between CML (used by the transition minimized differential signaling, TMDS, data and clock lanes) and the LVDS levels required by the ADN4624. Additional Analog Devices isolator components, such as the [ADuM1252](#) I²C isolators, [ADuM6028](#) isoPower integrated, isolated DC-DC converter, can be used to isolate control signals and power. In [CN0571](#), the implementation of an isolated HDMI PHY for 1080p resolution and 60Hz refresh rate is explained.

Other coupling networks, processing nodes, and translation circuits can use the ADN4624 as part of an overall signal chain to isolate MIPI CSI-2, DisplayPort, PCIe, SGMII, JESD204, Aurora and LVDS-based protocols such as FPD-Link. Use of an FPGA or an application-specific integrated circuit (ASIC) serializer/deserializer (SERDES) expands bandwidth through multiple ADN4624 devices to support 1080p or 4K video resolutions, providing an alternative to short reach fiber links.

APPLICATIONS INFORMATION

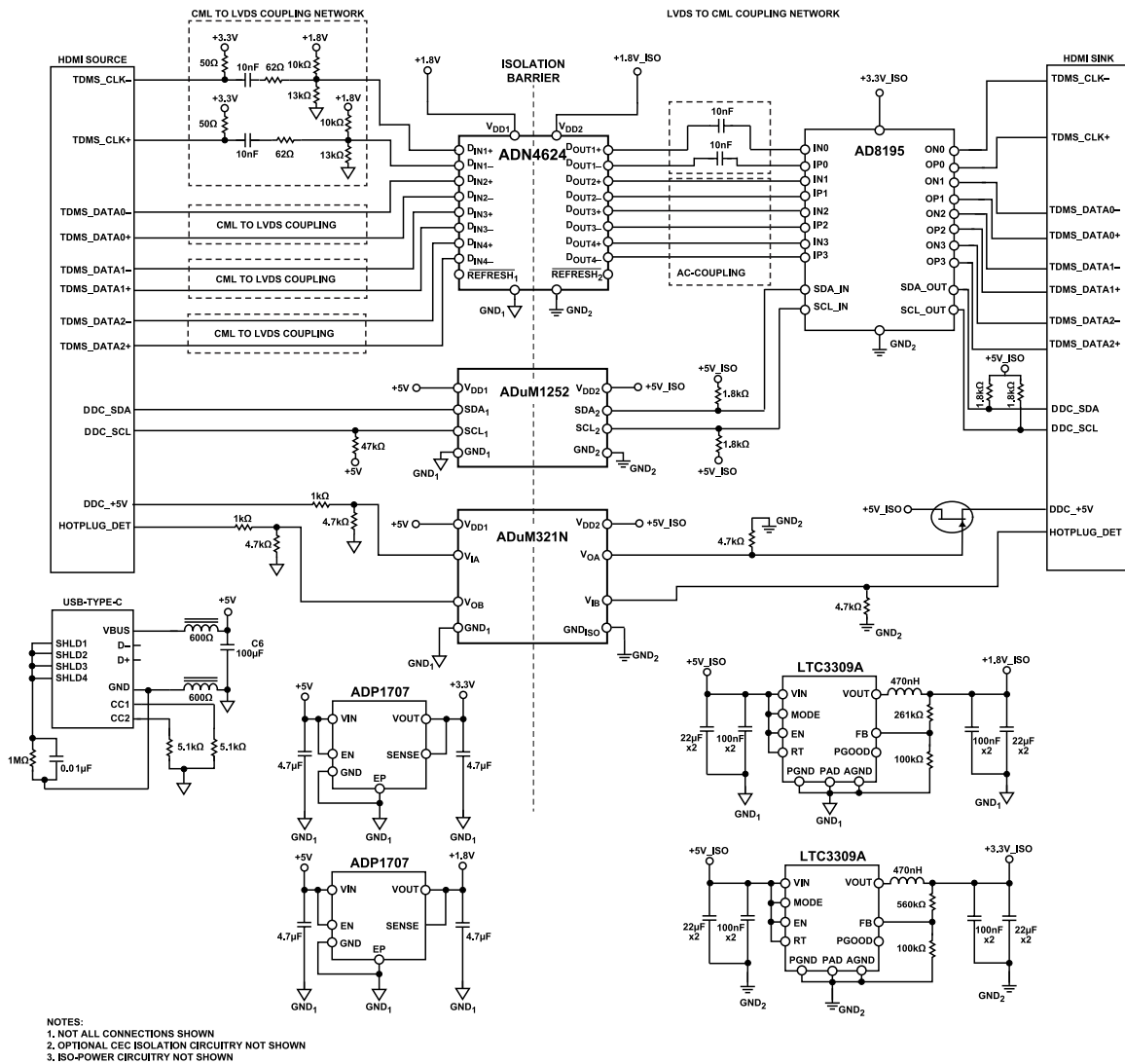

Figure 41. Example Isolated Video Interface (HDMI) Using the ADN4624

MAGNETIC FIELD IMMUNITY

The limitation on the magnetic field immunity of the device is set by the condition in which the induced voltage in the transformer receiving coil is sufficiently large, either to falsely set or reset the decoder. The following analysis defines such conditions. The ADN4622/ADN4624 is examined in a 1.7 V operating condition because this operating condition represents the most susceptible mode of operation for these products.

The pulses at the transformer output have an amplitude greater than 0.35 V. The decoder has a sensing threshold of about 0.11 V, therefore establishing a 0.24 V margin in which induced voltages are tolerated.

The voltage (V) induced across the receiving coil is given by

$$V = (-d\beta/dt) \sum \pi r_n^2; n = 1, 2, \dots, N \tag{1}$$

where:

$d\beta$ is the change in magnetic flux density.

dt is the change in time.

r_n is the radius of the n^{th} turn in the receiving coil.

N is the number of turns in the receiving coil.

Given the geometry of the receiving coil in the ADN4622/ADN4624 and an imposed requirement that the induced voltage be, at most, 50% of the 0.11 V threshold at the decoder, a maximum allowable external magnetic flux density is calculated as shown in Figure 42.

APPLICATIONS INFORMATION

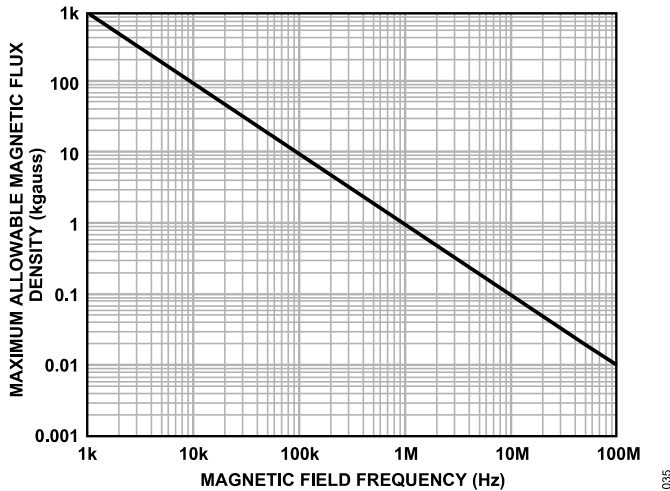

Figure 42. Maximum Allowable External Magnetic Flux Density

For example, at a magnetic field frequency of 1 MHz, the maximum allowable magnetic field of 1.06 kgauss induces a voltage of 0.055 V at the receiving coil. This voltage is about 50% of the sensing threshold and does not cause a faulty output transition. If such an event occurs with the worst case polarity during a transmitted pulse, the applied magnetic field reduces the received pulse from >0.35 V to 0.295 V. This voltage is still higher than the 0.11 V sensing threshold of the decoder.

The preceding magnetic flux density values correspond to specific current magnitudes at given distances from the ADN4622/ADN4624 transformers. Figure 43 expresses these allowable current magnitudes as a function of frequency for selected distances. The ADN4622/ADN4624 is insensitive to external fields. Only extremely large, high frequency currents that are close to the component can potentially be a concern. For the 1 MHz example noted, a 2.64 kA current must be placed 5 mm from the ADN4622/ADN4624 to affect component operation.

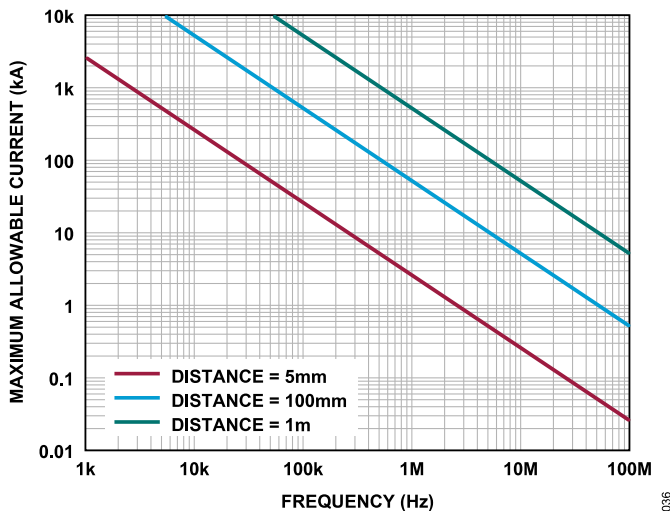

Figure 43. Maximum Allowable Current for Various Current to ADN4622/ADN4624 Spacings

In combinations of strong magnetic field and high frequency, any loops formed by PCB traces can induce sufficiently large error voltages to trigger the thresholds of succeeding circuitry. Avoid PCB structures that form loops.

INSULATION LIFETIME

All insulation structures eventually break down when subjected to voltage stress over a sufficiently long period. The rate of insulation degradation is dependent on the characteristics of the voltage waveform applied across the insulation. In addition to the testing performed by the regulatory agencies, Analog Devices carries out an extensive set of evaluations to determine the lifetime of the insulation structure within the AD7403

Analog Devices performs accelerated life testing using voltage levels higher than the rated continuous working voltage. Acceleration factors for several operating conditions are determined. These factors allow calculations of the time to failure at the actual working voltage. The values shown in Table 11 summarize the maximum continuous working voltages as per IEC 60747-17. Operation at working voltages higher than the service life voltage listed leads to premature insulation failure.

Surface Tracking

Surface tracking is addressed in electrical safety standards by setting a minimum surface creepage based on the working voltage, the environmental conditions, and the properties of the insulation material. Safety agencies perform characterization testing on the surface insulation of components, which allows the components to be categorized in different material groups. Lower material group ratings are more resistant to surface tracking and, therefore, can provide adequate lifetime with smaller creepage. The minimum creepage for a given working voltage and material group is in each system level standard and is based on the total RMS voltage across the isolation barrier, pollution degree, and material group. The material group and creepage for ADN4622/ADN4624 are detailed in Table 4.

Insulation Wear Out

The lifetime of insulation caused by wear out is determined by the thickness of the insulation, material properties, and the voltage stress applied. It is important to verify that the product lifetime is adequate at the application working voltage. The working voltage supported by an isolator for wear out may not be the same as the working voltage supported for tracking. The working voltage applicable to tracking is specified in most standards.

Testing and modeling show that the primary driver of long-term degradation is displacement current in the polyimide insulation causing incremental damage. The stress on the insulation can be broken down into broad categories, such as DC stress, which causes little wear out because there is no displacement current, and an AC component time varying voltage stress, which causes wear out.

APPLICATIONS INFORMATION

The ratings in certification documents are usually based on 60 Hz sinusoidal stress because this type of waveform reflects isolation from line voltage. However, many practical applications have combinations of 60 Hz AC and DC across the isolation barrier, as shown in [Equation 2](#). Because only the AC portion of the stress causes wear out, the equation can be rearranged to solve for the AC RMS voltage, as shown in [Equation 3](#). For insulation wear out with the polyimide materials used in this product, the AC RMS voltage determines the product lifetime.

$$V_{RMS} = \sqrt{V_{AC\ RMS}^2 + V_{DC}^2} \quad (2)$$

or

$$V_{AC\ RMS} = \sqrt{V_{RMS}^2 - V_{DC}^2} \quad (3)$$

where:

V_{RMS} is the total RMS working voltage.

$V_{AC\ RMS}$ is the time varying portion of the working voltage.

V_{DC} is the DC offset of the working voltage.

Calculation and Use of Parameters Example

The following example frequently arises in power conversion applications. Assume that the line voltage on one side of the isolation is 240 V AC RMS and a 400 V DC bus voltage is present on the other side of the isolation barrier. The isolator material is polyimide. To establish the critical voltages in determining the creepage, clearance, and lifetime of a device, see [Figure 44](#) and the following equations.

The working voltage across the barrier from [Equation 2](#) is

$$V_{RMS} = \sqrt{V_{AC\ RMS}^2 + V_{DC}^2} \quad (4)$$

$$V_{RMS} = \sqrt{240^2 + 400^2} \quad (5)$$

$$V_{RMS} = 466\text{ V}$$

This V_{RMS} value is the working voltage used together with the material group and pollution degree when looking up the creepage required by a system standard.

To determine if the lifetime is adequate, obtain the time varying portion of the working voltage. To obtain the AC RMS voltage, use [Equation 3](#).

$$V_{AC\ RMS} = \sqrt{V_{RMS}^2 - V_{DC}^2} \quad (6)$$

$$V_{AC\ RMS} = \sqrt{466^2 - 400^2} \quad (7)$$

$$V_{AC\ RMS} = 240\text{ V RMS}$$

In this case, the AC RMS voltage is simply the line voltage of 240 V RMS. This calculation is more relevant when the waveform is not sinusoidal.

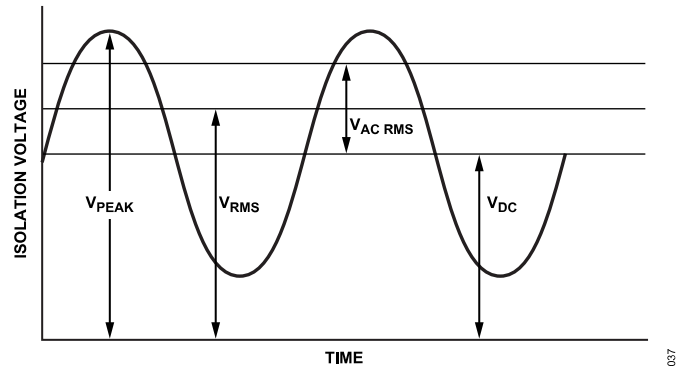

Figure 44. Critical Voltage Example

OUTLINE DIMENSIONS

Package Drawing (Option)	Package Type	Package Description
RN-28-1	SOIC_W_FP	28-Lead Standard Small Outline, Wide Body, with Finer Pitch
CP-32-32	LFCSP	32-Lead Lead Frame Chip Scale Package

For the latest package outline information and land patterns (footprints), go to [Package Index](#).

ORDERING GUIDE

Model ¹	Temperature Range	Package Description	Packing Quantity	Package Option
ADN4622BRNZ	-40°C to +125°C	28-Lead SOIC (Wide, Finer Pitch)	Tube, 46	RN-28-1
ADN4622BRNZ-RL	-40°C to +125°C	28-Lead SOIC (Wide, Finer Pitch)	Reel, 1000	RN-28-1
ADN4622BCPZ	-40°C to +125°C	32-Lead LFCSP (6 mm x 6 mm)	Tray, 490	CP-32-32
ADN4622BCPZ-RL	-40°C to +125°C	32-Lead LFCSP (6 mm x 6 mm)	Reel, 2500	CP-32-32
ADN4624BRNZ	-40°C to +125°C	28-Lead SOIC (Wide, Finer Pitch)	Tube, 46	RN-28-1
ADN4624BRNZ-RL	-40°C to +125°C	28-Lead SOIC (Wide, Finer Pitch)	Reel, 1000	RN-28-1
ADN4624BCPZ	-40°C to +125°C	32-Lead LFCSP (6 mm x 6 mm)	Tray, 490	CP-32-32
ADN4624BCPZ-RL	-40°C to +125°C	32-Lead LFCSP (6 mm x 6 mm)	Reel, 2500	CP-32-32

¹ Z = RoHS Compliant Part.



EVALUATION BOARDS

Model ¹	Description
EVAL-ADN4622EB1Z	ADN4622 SOIC_W_FP Evaluation Board
EVAL-ADN4624EB1Z	ADN4624 SOIC_W_FP Evaluation Board

¹ Z = RoHS Compliant Part.

Looking for pricing, stock, or lifecycle information?

Click below to explore more details on WIN SOURCE:

-  [View BSH205G2AR on WIN SOURCE](#)
-  [Nexperia USA Inc. Information](#)

Optimize Your Supply Chain with WIN SOURCE Solutions

-  Global Sourcing Solution
-  Obsolete Management
-  Cost Control Management
-  Shortage Management
-  Alternative Solution
-  Excess Inventory Management