



**THE DATASHEET OF
AL8866QSP-13**



Description

The AL8866Q is a Buck-Boost, Boost, Buck and SEPIC (single-ended primary-inductance converter) DC-Switching controller designed to drive an external MOSFET for high power automotive LED applications such as automotive front lighting. The AL8866Q operates within a wide input power supply range from 4.7V to 85V.

The AL8866Q bases on a fixed-frequency, peak current-mode control architecture to incorporate spread spectrum frequency modulation technique and achieve Low EMI performance.

The AL8866Q modulates LED current with analog or PWM dimming techniques. Analog dimming response with over 100:1 Linear range is obtained by varying the voltage at the DIM pin. PWM dimming is achieved by directly modulating the same DIM pin with the desired duty cycle.

The AL8866Q integrates soft-start function which limits the current through the inductor and external power switch during initialization start up. It gradually increases the inductor and switch current to minimize potential overvoltage and overcurrent at the output.

The AL8866Q with an open drain fault output indicates protection conditions triggered like LED output overvoltage, LED output open/short, cycle by cycle overcurrent protection, sense resistor and inductor/diode shorted, diode open and thermal shutdown.

The AL8866Q is available in the enhanced thermal SO-8EP and U-DFN3030-10 packages.

Features

- AEC-Q100 (Grade 1)
- Wide Input Voltage Range from 4.7V to 85V
- Pre-Fixed 400kHz Switching Frequency (Factory Set)
- Spread Spectrum Frequency Modulation for Low EMI
- Analog Dimming Range: 1% to 100%
 - 100% Dimming Level $\pm 3\%$ Current Accuracy
 - 20% Dimming Level $\pm 12\%$ Current Accuracy
- PWM Dimming Ratio 100:1 at 200Hz PWM Frequency
- Programmable Soft Start
- Fault Status Indicator for Protections
- Output Overvoltage and LED Open Circuit Protection
- Output Undervoltage and LED Short Circuit Protection
- Cycle-by-Cycle Overcurrent Limitation Protection
- Sense Resistor Shorted Circuit Protection
- Diode/Inductor Shorted Circuit Protection
- Diode Open Circuit Protection
- Thermal Shutdown
- **Totally Lead-Free & Fully RoHS Compliant (Notes 1 & 2)**
- **Halogen and Antimony Free. "Green" Device (Note 3)**
- **The AL8866Q is suitable for automotive applications requiring specific change control; this part is AEC-Q100 qualified, PPAP capable, and manufactured in IATF 16949 certified facilities.**

<https://www.diodes.com/quality/product-definitions/>

Notes:

1. No purposely added lead. Fully EU Directive 2002/95/EC (RoHS), 2011/65/EU (RoHS 2) & 2015/863/EU (RoHS 3) compliant.
2. See <https://www.diodes.com/quality/lead-free/> for more information about Diodes Incorporated's definitions of Halogen- and Antimony-free, "Green" and Lead-free.
3. Halogen- and Antimony-free "Green" products are defined as those which contain <900ppm bromine, <900ppm chlorine (<1500ppm total Br + Cl) and <1000ppm antimony compounds.

Pin Assignments

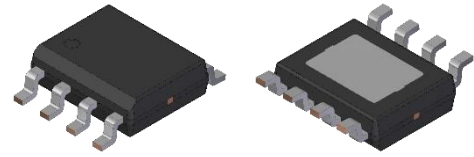

Top View

Bottom View

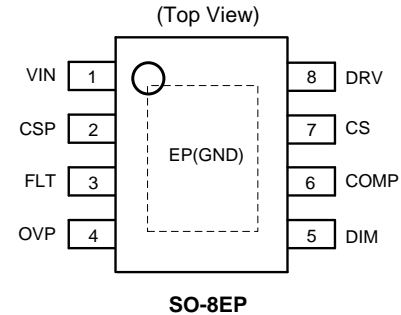

Top View

Bottom View

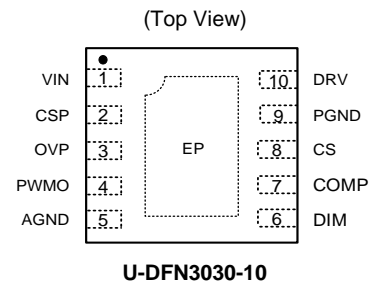

Applications

- Automotive front lightings
- Automotive high beams, low beams
- Automotive daytime running lights
- Automotive fog lights, turn lights and position lights
- Other automotive LED lightings

Typical Applications Circuit

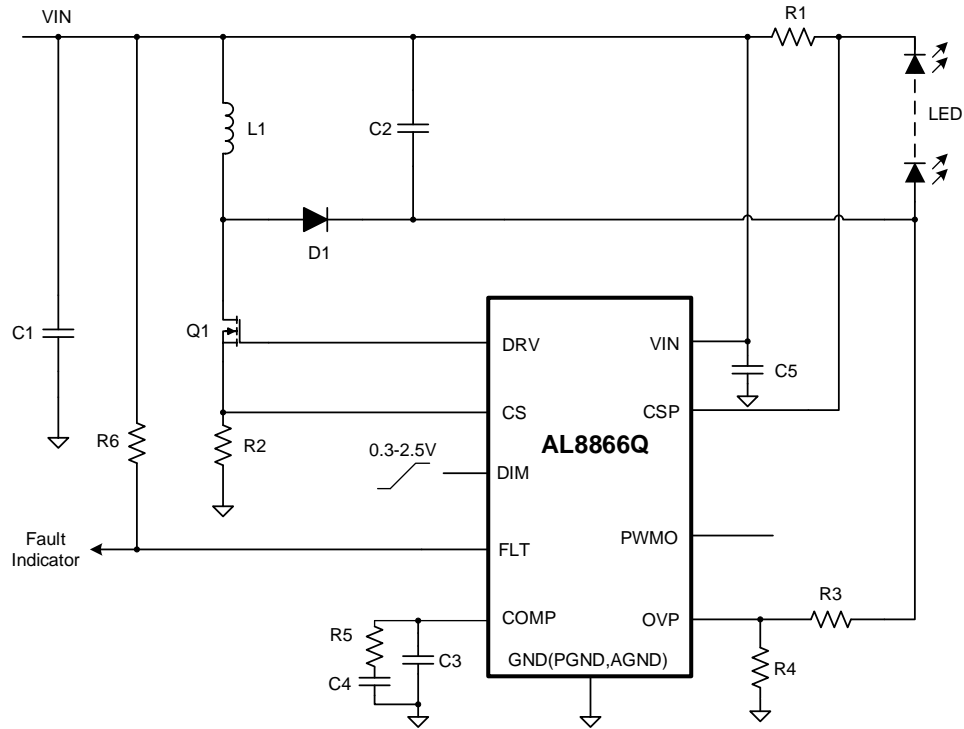

Figure 1 Typical Buck-Boost LED Driver Application

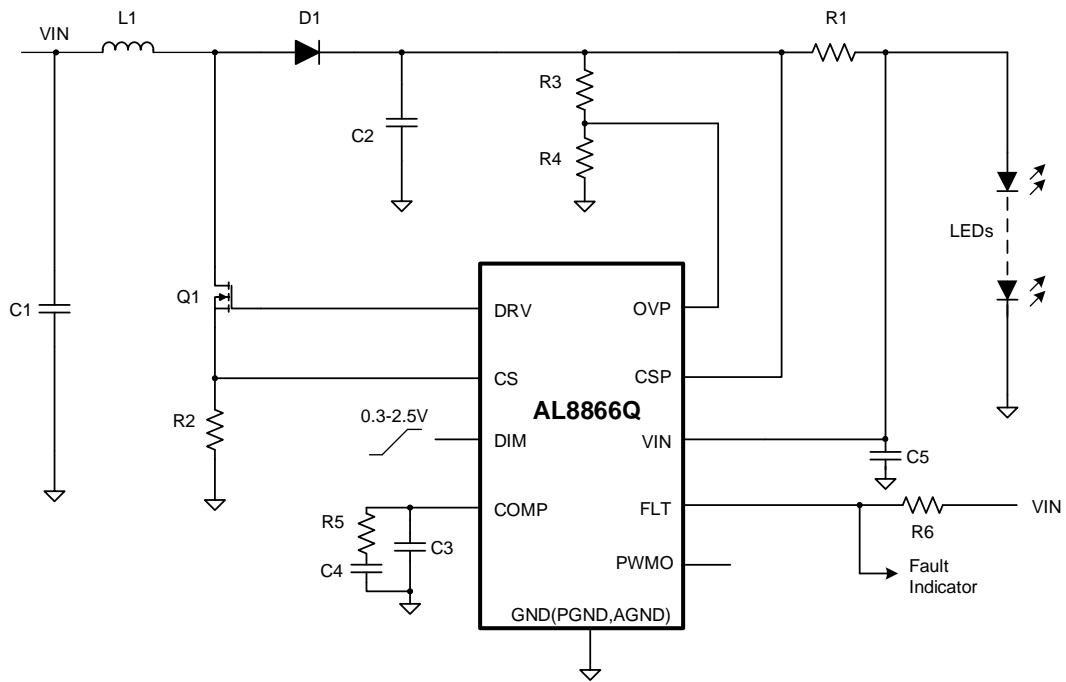

Figure 2 Typical Boost LED Driver Application

Typical Applications Circuit (continued)

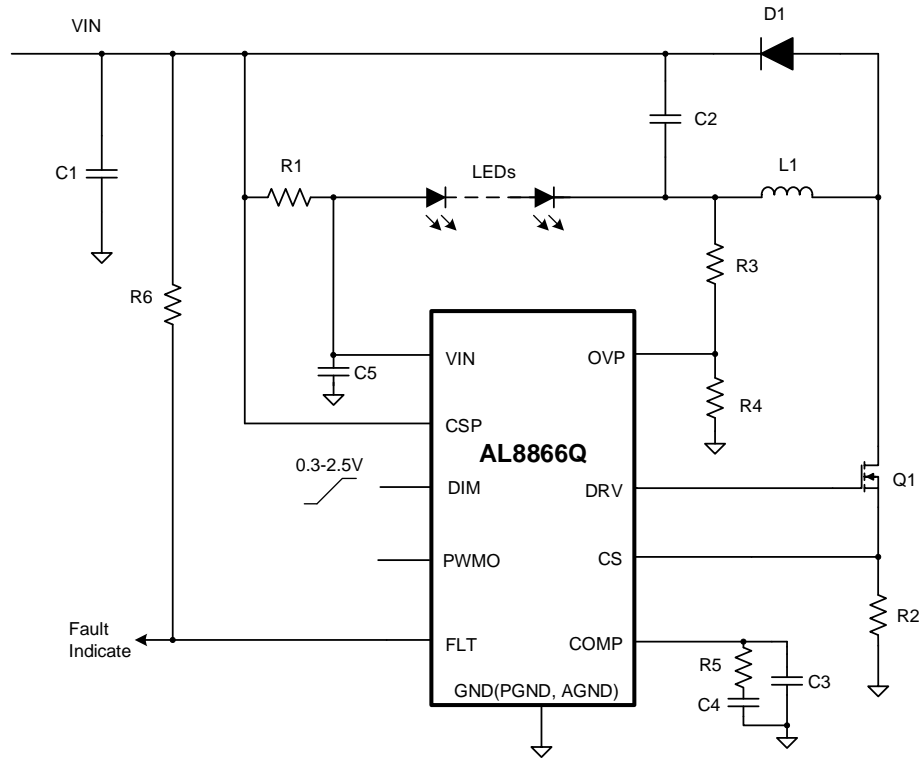

Figure 3 Typical Buck LED Driver Application

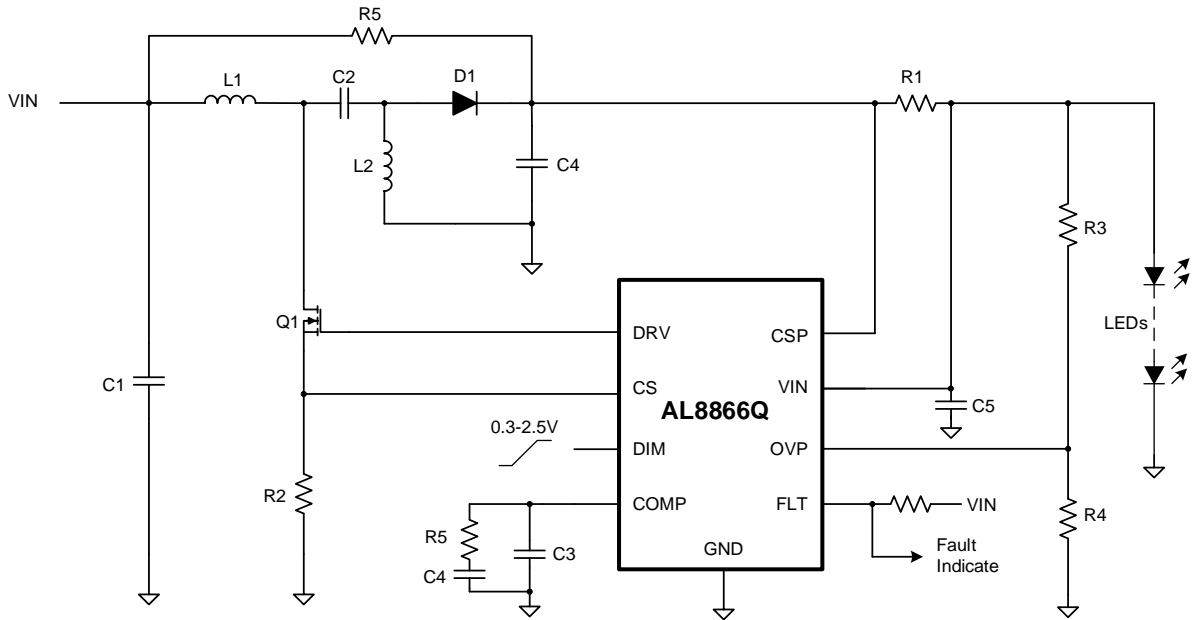

Figure 4 Typical SEPIC LED Driver Application

Pin Descriptions

Pin Number		Pin Name	Function
SO-8EP	U-DFN3030-10	—	
1	1	VIN	Input voltage. Decouple to ground with 1 μ F or higher X7R ceramic capacitor close to device.
2	2	CSP	Current sense amplifier positive input. Connect current sense resistor from CSP to VIN for current sense control.
3	—	FLT	Fault report pin. Asserted low to report faulty conditions. Needs an external pull-up resistor.
4	3	OVP	Input pin for Output Overvoltage and Output Under Voltage protection. Connected to resistive voltage divider or LED voltage sense circuits to set the over voltage threshold and output under voltage threshold.
5	6	DIM	Multi-function On/Off and brightness control pin: <ul style="list-style-type: none"> • Leave floating for normal operation. • Drive to voltage below 0.2V to stop the device switching. • Drive to voltage below 0.2V for longer than 30ms to shut down the device. • Drive with DC voltage (0.3V < VSET < 2.5V) to adjust output current from 0% to 100% of IOUT_NOM. • A PWM signal (low level < 0.2V, high level > 2.6V, transition times less than 1μs) allows the output current to be adjusted over a wide range up to 100%. • Connect a capacitor from this pin to ground to increase soft-start time.
6	7	COMP	Compensation output. Connect compensation network to achieve desired closed-loop response.
7	8	CS	Switch current sense input. Connect to the switch sense resistor to set the switch current limit threshold based on the internal reference voltage. Add a resistor from CS to the switching-MOSFET current-sense resistor terminal for programming the slope compensation.
8	10	DRV	N-channel MOSFET gate driver output. Connect to gate of external main switching N-channel MOSFET.
—	4	PWMO	The output pin for PMOS gate driving in PWM dimming operation.
NA	5	AGND	Analog ground.
NA	9	PGND	Power ground.
EP	EP	GND	Exposed pad must connect to GND for SO-8EP.

Functional Block Diagram

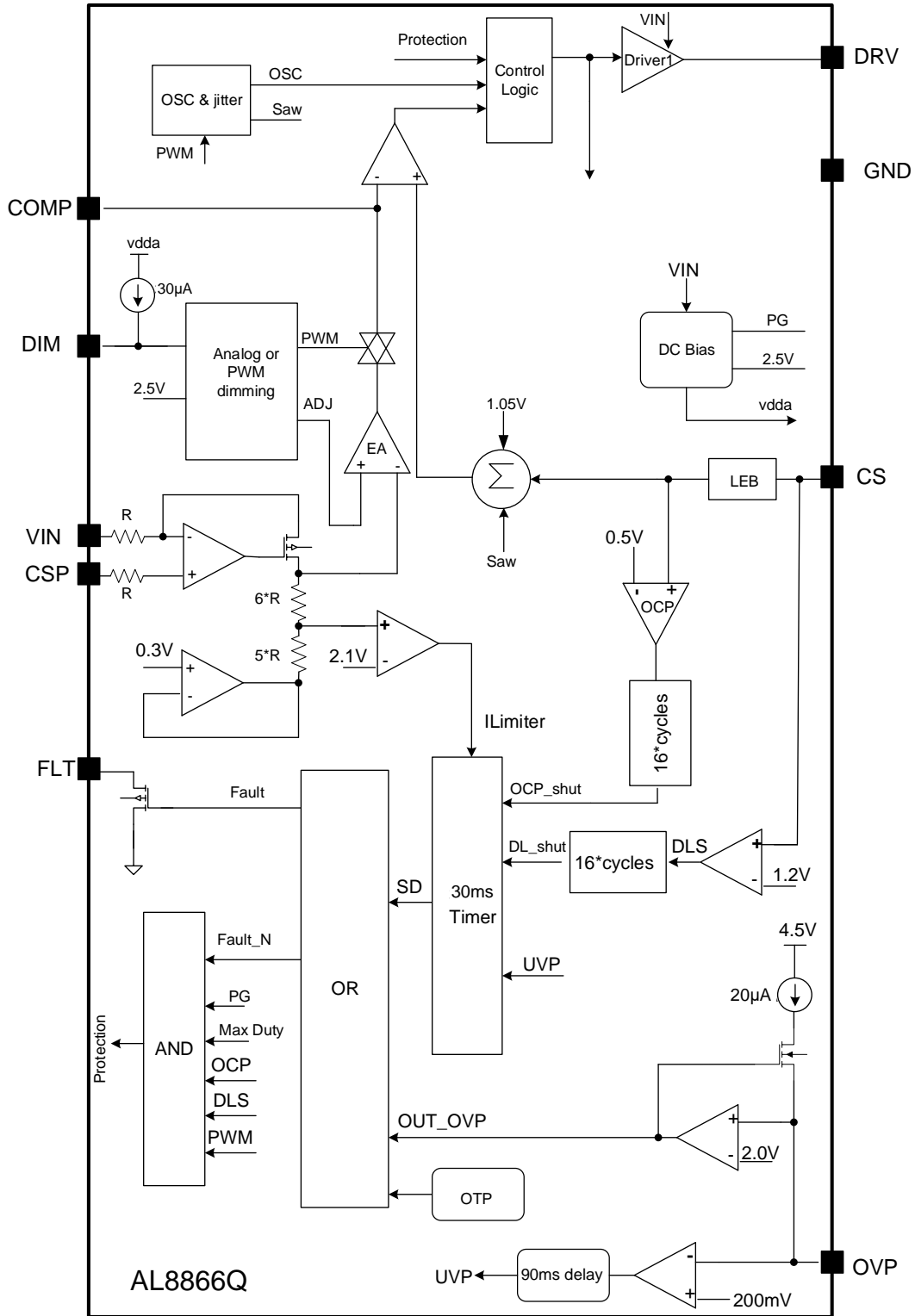

Figure 5 Block Diagram of AL8866QSP-13

Functional Block Diagram

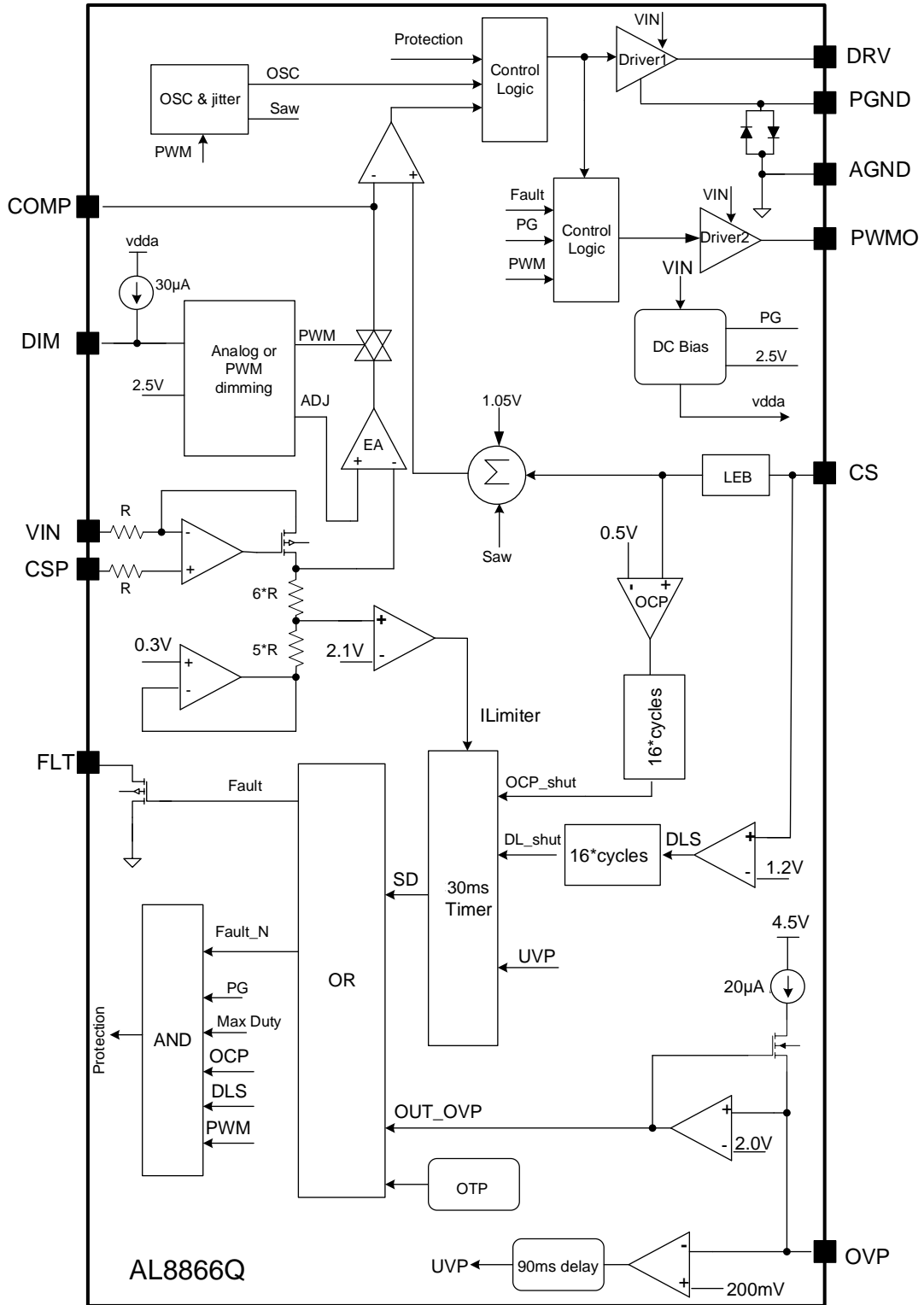

Figure 6 Block Diagram of AL8866QFN-7

Absolute Maximum Ratings (Note 4)

Symbol	Parameter	Rating	Unit
V _{VIN} , V _{CSP} , V _{F_{LT}} , V _{OVP} , V _{DIM}	Voltage on VIN, CSP, FLT, OVP, DIM Pins	-0.3 to +86	V
V _{DRV}	Voltage on DRV Pin	-0.3 to +20	V
V _{CS}	Voltage on CS Pin	-0.3 to +45	V
V _{COMP} , V _{PWMO}	Voltage on COMP, PWMO Pin	-0.3 to +6	V
T _J	Operating Junction Temperature	-40 to +150	°C
T _{STG}	Storage Temperature Range	-65 to +165	°C

Note: 4. Stresses greater than those listed under “Absolute Maximum Ratings” can cause permanent damage to the device. These are stress ratings only, and functional operation of the device at these or any other conditions beyond those indicated under “Recommended Operating Conditions” is not implied. Exposure to “Absolute Maximum Ratings” for extended periods can affect device reliability.

ESD Ratings

Symbol	Parameter	Rating	Unit
V _{ESD}	Human-Body Model (HBM), per AEC-Q100-002 (Note 5)	±2000	V
	Charged-Device Model (CDM), per AEC-Q100-011	±1000	

Note: 5. AEC-Q100-002 indicates that HBM stressing shall be accordance with the ANSI/ESDA/JEDEC JS-001 specification.

Recommended Operating Conditions

Symbol	Parameter	Min	Typ	Max	Unit
V _{IN}	Input Voltage	4.7	—	85	V
F _{PWM}	PWM Dimming Frequency	100	—	1000	Hz
f _{SW}	Operating Frequency	—	400	—	kHz
—	Analog Dimming Range	1	—	100	%
T _A	Operating Ambient Temperature	-40	—	+125	°C

Thermal Information (Note 6)

Package	Symbol	Parameter	Rating	Unit
SO-8EP	R _{θJA}	Junction-to-Ambient Thermal Resistance	63.6	°C/W
	R _{θJC(TOP)}	Junction-to-Case (Top) Thermal Resistance	75.5	°C/W
	R _{θJC(BOTTOM)}	Junction-to-Case (Bottom) Thermal Resistance	2.54	°C/W
	R _{θJB}	Junction-to-Board Thermal Resistance	21.8	°C/W
	Ψ _{jt}	Junction-to-Top Characterization Parameter	7.2	°C/W
	Ψ _{jb}	Junction-to-Board Characterization Parameter	22.4	°C/W
U-DFN3030-10	R _{θJA}	Junction-to-Ambient Thermal Resistance	51.8	°C/W
	R _{θJC(TOP)}	Junction-to-Case (Top) Thermal Resistance	49.7	°C/W
	R _{θJC(BOTTOM)}	Junction-to-Case (Bottom) Thermal Resistance	1.5	°C/W
	R _{θJB}	Junction-to-Board Thermal Resistance	16.6	°C/W
	Ψ _{jt}	Junction-to-Top Characterization Parameter	1.1	°C/W
	Ψ _{jb}	Junction-to-Board Characterization Parameter	16.9	°C/W

Note: 6. Device mounted on 2" × 2" FR-4 substrate PCB, 2oz copper, with minimum recommended pad layout.

Electrical Characteristics ($T_A = -40^{\circ}\text{C}$ to $+125^{\circ}\text{C}$, $V_{IN} = 12\text{V}$, unless otherwise specified.)

Symbol	Parameter	Conditions	Min	Typ	Max	Unit
INPUT VOLTAGE (VIN)						
VINUVLO	Under-Voltage Lockout Voltage	VIN Rising Threshold	4.2	4.5	4.7	V
		VIN Falling Threshold	3.8	4.2	4.4	V
		UVLO Hysteresis	145	300	500	mV
Iq	Quiescent Current	No Switching	0.9	1.8	2.5	mA
		Switching COMP = 3V, CDRV = 1nF	—	6.5	—	mA
ISHDN	Shutdown Supply Current	DIM < 0.2V, Disable Time ≥ 30ms	8	30	60	μA
OSCILLATOR						
fsw	Switching Frequency Range	V _{DIM} = 2V	360	400	440	kHz
DMAX	Maximum Duty Cycle	—	89	95	99	%
fdITH	Frequency Dither	—	±6	±12	±16	%
fm	Dither Modulation Frequency (Note 7)	—	—	400	—	Hz
LED CURRENT REGULATION (CSP, VIN)						
VSNS	Current Sense Threshold, Voltage between CSP and VIN Pin	V _{DIM} = 2.5V	194	200	206	mV
		V _{DIM} = 0.74V	35	40	45	
ICSP	CSP Pin Input Current	V _{IN} = V _{CSP} + 0.1V	9	16	30	μA
GATE DRIVER (DRV)						
T _{RISE}	Gate Driver Rising Time	C _{DRV} = 1nF	18	40	70	ns
T _{FALL}	Gate Driver Falling Time	C _{DRV} = 1nF	18	35	70	ns
R _{GH}	Gate Driver High Side Resistance	I _{DRV} = -100mA	2	10	21	Ω
R _{GL}	Gate Driver Low Side Resistance	I _{DRV} = 100mA	0.9	4	10	Ω
V _{DRV_CLAMP}	Clamp Voltage On DRV Output	V _{IN} = 18V	10.0	11.0	12.2	V
INDUCTOR CURRENT SENSE (CS)						
V _{CS_LIMIT1}	Current Limit Threshold Voltage	—	450	500	550	mV
V _{CS_LIMIT2}	CS High Protection Threshold	Diode or Inductor Short	1.1	1.2	1.3	V
ISLOPE	Slope-Compensation Current-Ramp Height	Peak Current Ramp Added to CS Input per Switching Cycle	40	52	80	μA
ANALOG DIMMING (DIM)						
V _{DIM}	Voltage Range On DIM Pin	For Analog Dimming	0.3	—	2.5	V
V _{DIM_CLAMP}	DIM Internal Clamp Voltage	—	3.4	4.0	4.5	V
V _{DIM_ON}	DC Voltage On DIM Pin for Analog Dimming On	V _{DIM} Rising	0.275	0.330	0.385	V
V _{DIM_OFF}	DC Voltage On DIM Pin for Analog Dimming Off	V _{DIM} Falling	0.28	0.30	0.32	V
t _{DIM_DIS}	Disable Time for Entering Standby Mode	DIM = Low	—	30	—	ms
I _{DIM}	DIM Sourcing Current	—	28.5	30	31.5	μA

Note: 7. The parameter is guaranteed by design, not 100% tested in production.

Electrical Characteristics ($T_A = -40^{\circ}\text{C}$ to $+125^{\circ}\text{C}$, $V_{IN} = 12\text{V}$, unless otherwise specified. continued)

Symbol	Parameter	Conditions	Min	Typ	Max	Unit
ERROR AMPLIFIER (COMP)						
g_M	Transconductance of EA	—	80	105	130	$\mu\text{A/V}$
I_{SOURCE}	COMP Output Source Current	—	120	140	170	μA
I_{SINK}	COMP Output Sink Current	—	120	140	170	μA
OUTPUT OVERVOLTAGE PROTECTION AND OUTPUT UNDERVOLTAGE PROTECTION (OVP)						
V_{OVP}	Overvoltage Protection Threshold	—	1.9	2.0	2.1	V
V_{UVP}	Undervoltage Protection Threshold	—	180	200	220	mV
I_{OVP_HYS}	OVP Hysteresis Current	—	12	20	27.5	μA
PWMO OUTPUT						
V_H	PWMO Internal Clamp Voltage	—	3.8	4.6	6	V
R_{PWMO_H}	PWMO Driver High Side Resistance	$I_{DRV} = -10\text{mA}$	—	100	—	Ω
R_{PWMO_L}	PWMO Driver Low Side Resistance	$I_{DRV} = 10\text{mA}$	—	5	—	Ω
FAULT FLAG (FLT)						
V_{FAULT_LOW}	FAULT Output Low Voltage	$V_{IN} = 4.75\text{V}$, $V_{OVP} = 2\text{V}$, $I_{FAULT} = 5\text{mA}$	—	—	200	mV
I_{FAULT_LEAK}	FAULT Leakage Current	$V_{FAULT} = 85\text{V}$	—	—	1	μA
THERMAL SHUTDOWN						
T_{TSD}	Thermal Shutdown Threshold	—	—	+170	—	$^{\circ}\text{C}$
T_{TSD_HYS}	Thermal Shutdown Hysteresis	—	—	+25	—	$^{\circ}\text{C}$

Typical Performance Characteristics ($T_A = -40^{\circ}\text{C}$ to $+125^{\circ}\text{C}$, $V_{IN} = 12\text{V}$, unless otherwise specified.)

Under Voltage Lockout vs Temperature

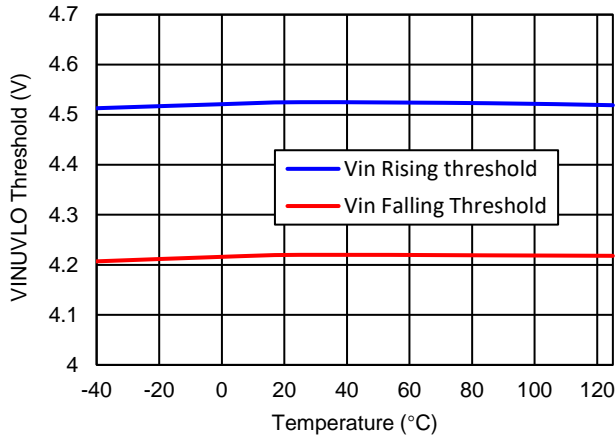

Quiescent Current (No Switching) vs Temperature

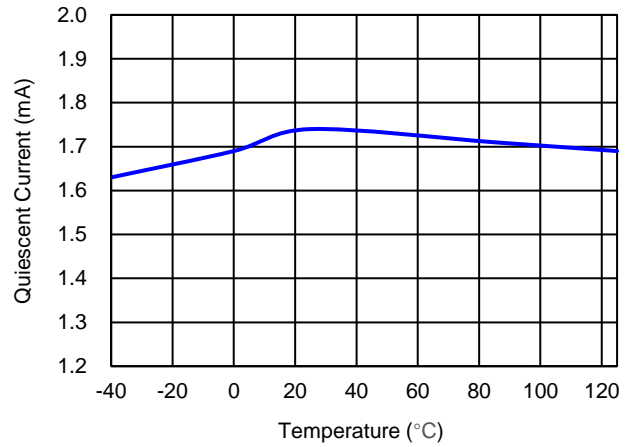

Quiescent Current (Switching) vs Temperature

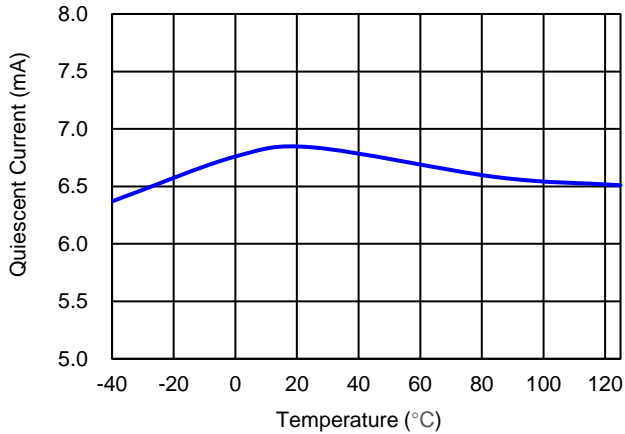

Switch Frequency vs Temperature

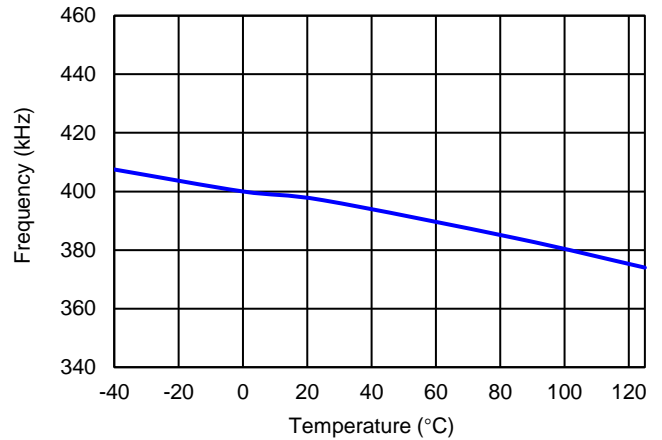

Current Sense VSNS vs Temperature

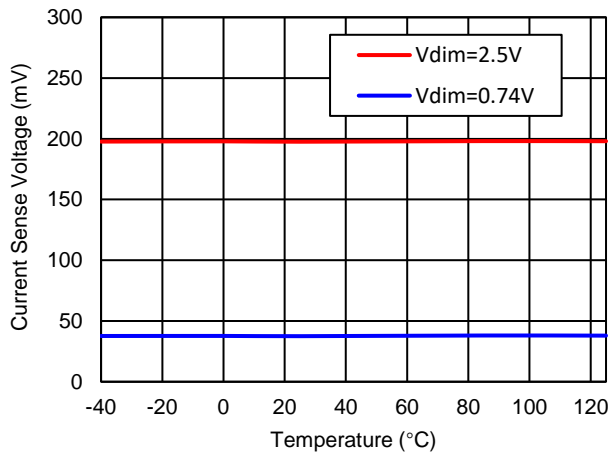

Inductor Current Limit Voltage vs Temperature

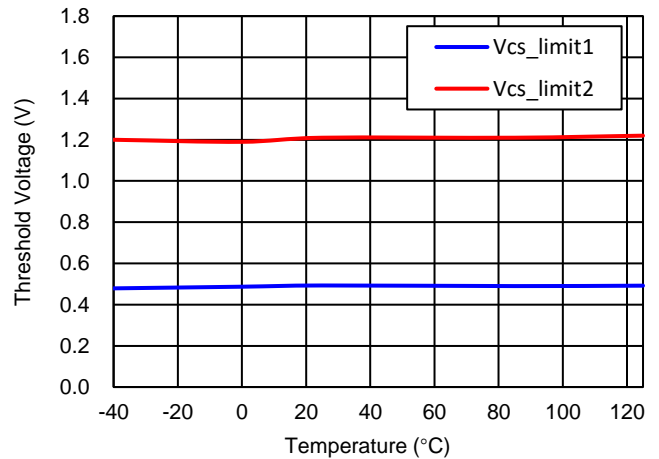

Typical Performance Characteristics ($T_A = -40^{\circ}\text{C}$ to $+125^{\circ}\text{C}$, $V_{IN} = 12\text{V}$, unless otherwise specified.)

DIM ON/OFF Voltage vs Temperature

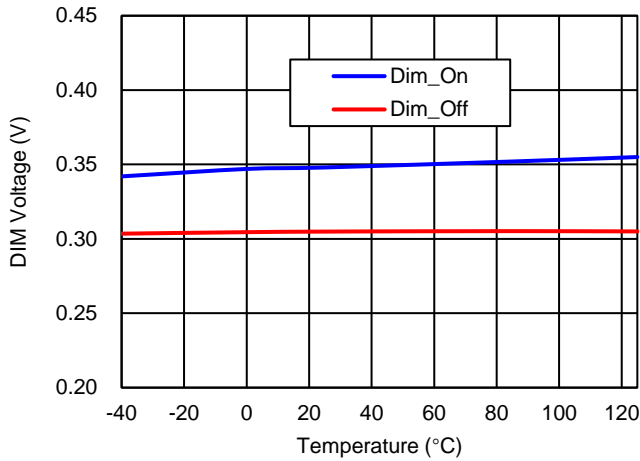

VDIM_Clamp vs Temperature

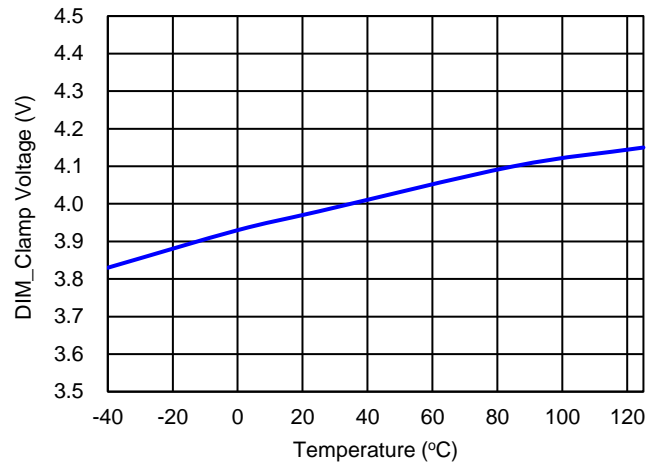

DIM Current vs Temperature

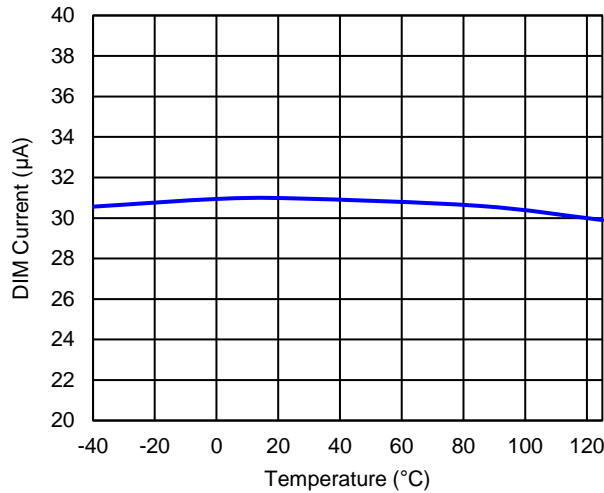

Fault Output Low Voltage vs Temperature

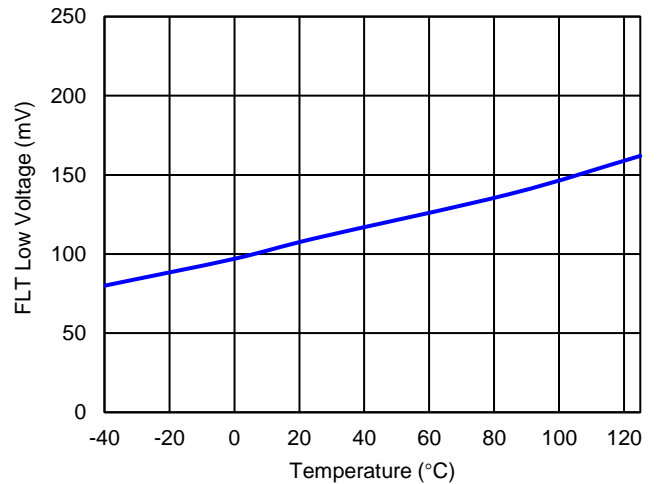

Error Amplifier GM vs Temperature

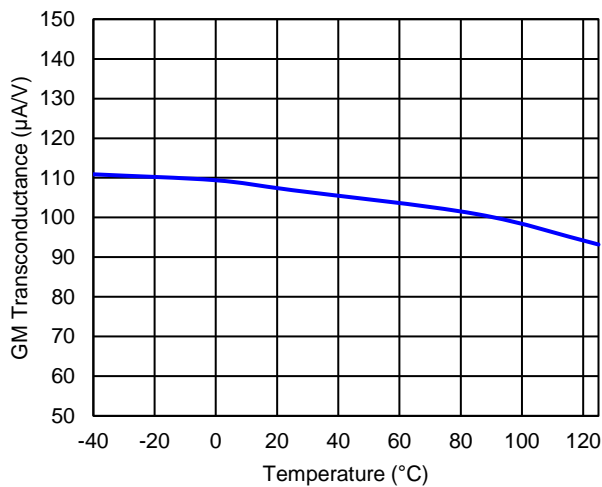

Overvoltage Protection Voltage vs Temperature

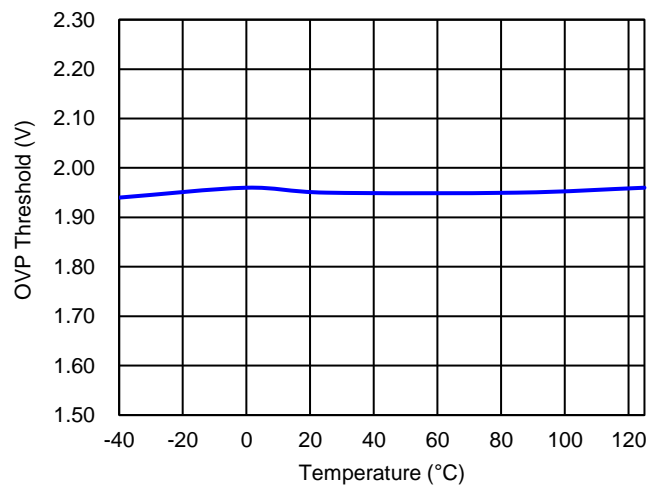

Typical Performance Characteristics ($T_A = -40^{\circ}\text{C}$ to $+125^{\circ}\text{C}$, $V_{IN} = 12\text{V}$, unless otherwise specified.)

Buck-Boost Efficiency

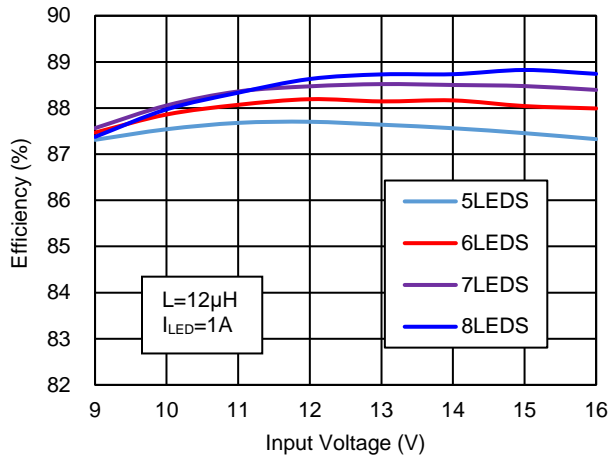

Boost Efficiency

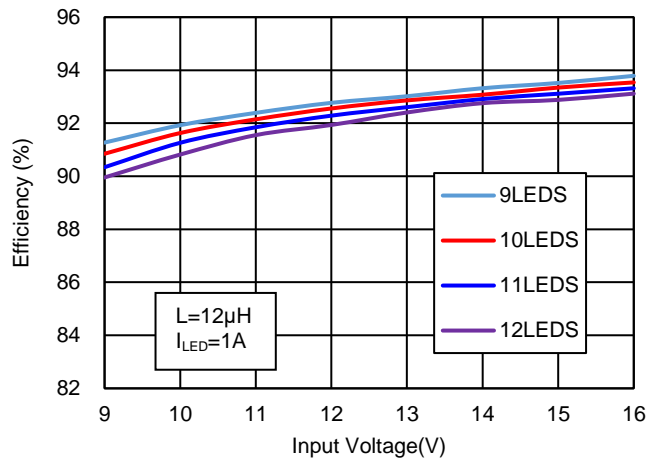

Buck Efficiency

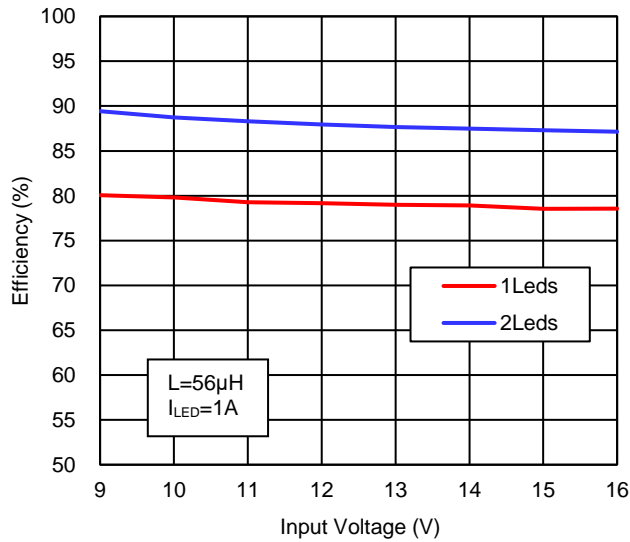

SEPIC Efficiency

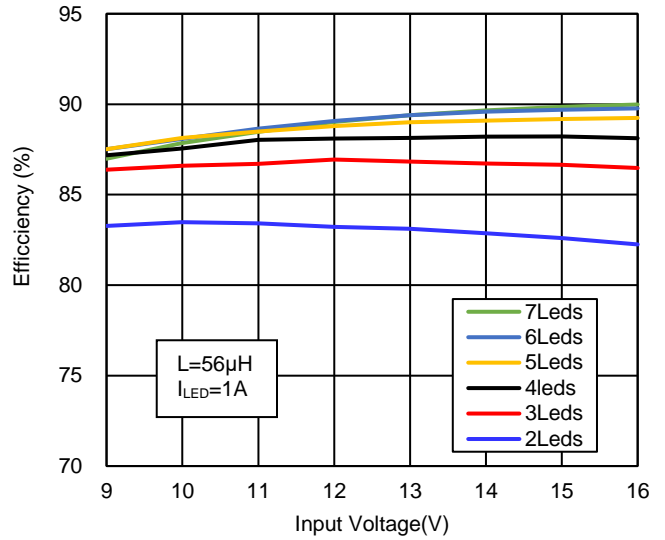

Application Information Overview

The AL8866Q implements a fixed-frequency, peak current-mode control technique to achieve constant output LED current and fast transient response. The integrated high accuracy current sense amplifier provides the flexibility required to power a single string consisting of 1 to 27 series connected LEDs while maintaining better than 3% current accuracy over the operation range. The AL8866Q can be designed to support multiple LED driver topology, such as Buck, Boost, Buck-Boost and SEPIC (single-ended primary-inductance converter).

LED Current Setting

The internal current sense amplifier measures the average LED current based on the differential voltage drop between the CSP and VIN inputs over a common mode range of 4.7V to 85V. The differential voltage, V_{SNS} , is amplified by a voltage-gain factor of 11 and is connected to the negative input of the transconductance error amplifier. The feedback loop will regulate the LED current to the target value set by internal voltage V_{ADJ} at the positive input of the error amplifier. The internal voltage V_{ADJ} is linearly regulated by the DC voltage on the DIM pin. If the voltage is higher than 2.5V or PWM signal is applied to DIM pin, the LED current is programmed by the LED sense resistor, R_{SENSE} , between CSP pin and VIN pin, according to:

$$I_{LED} = \frac{V_{SNS}}{R_{SENSE}} = \frac{200 \text{ mV}}{R_{SENSE}}$$

Spread Spectrum

The AL8866Q incorporates spread spectrum frequency modulation technique for low EMI performance. The switching frequency is modulated by $\pm 12\%$ of nominal frequency at a rate of 400Hz via a triangular waveform. In one modulation cycle, the switching frequency varies linearly from a minimum to a maximum to a minimum again. The AL8866Q would disable spread spectrum function when the voltage on DIM pin lower than 1V and re-activates this function when the voltage on DIM pin exceeds 1.1V. The average switching frequency of the AL8866Q is 400kHz typically when spread spectrum is active, and 360kHz typically when spread spectrum is disabled.

Slope Compensation

Slope compensation can be added to the MOSFET current-sense signal on CS pin to prevent subharmonic oscillations at duty cycles greater than 50%. During switching, a current source of saw tooth from 0 to 50 μ A is sourced from the CS input. An external resistor, R_{SLOPE} , connected between the CS pin and the source connection of the MOSFET, is used to program the appropriate amount of slope compensation.

PWM Dimming

The AL8866Q supports directive PWM dimming operation. The LED current can be adjusted digitally by applying a low frequency Pulse-Width-Modulated (PWM) logic signal to the PWM pin to turn the device on and off. This will produce an average output current proportional to the duty cycle of the control signal. To achieve a high resolution, the PWM frequency is recommended to be lower than 1kHz, however high dimming frequencies can be used, at the expense of dimming dynamic range and accuracy. The LED string would flicker at low dimming level in PWM dimming operation, recommend 3% minimum dimming level for 200Hz and 10% minimum dimming level for 1kHz. The dimming curve below shows the typical dimming range for this kind of dimming operation.

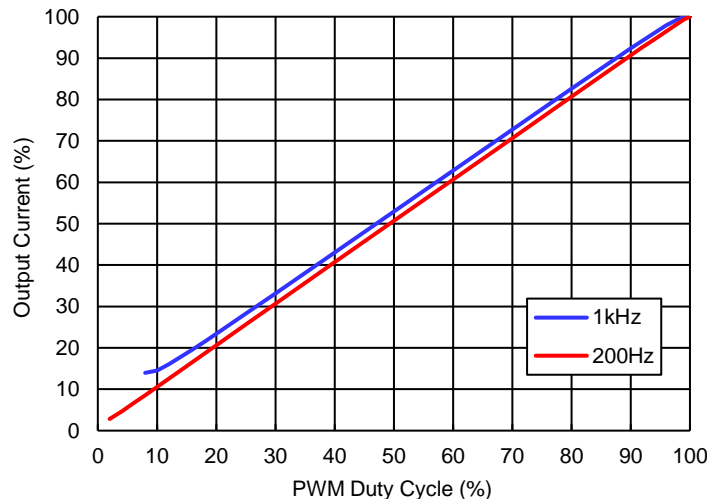

Figure 7 PWM Dimming Curve without PMOS Driving on Output on Buck-Boost

Application Information (continued)

To achieve better linearity of dimming curve in directive PWM dimming mode, the AL8866QFN-7 integrates PWMO output as dimming MOSFET driving. The driving signal is synchronizing with PWM dimming signal on PWM pin in normal status. Once a fault is triggered, the PWMO output low to turn off dimming MOSFET to protect LED load.

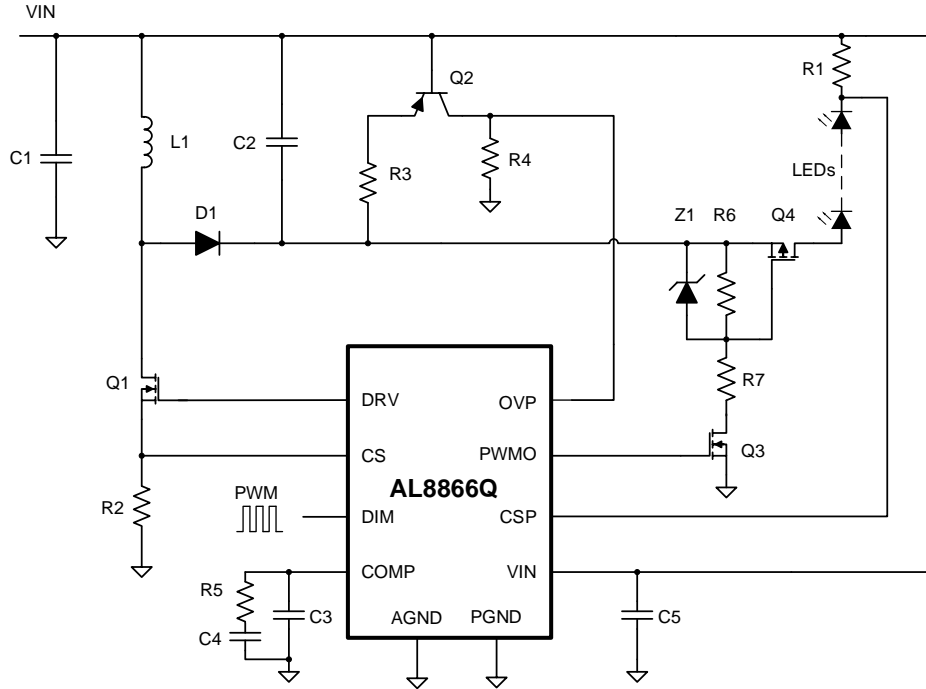

Figure 8 Buck-Boost LED Driver with PWM Dimming Operation

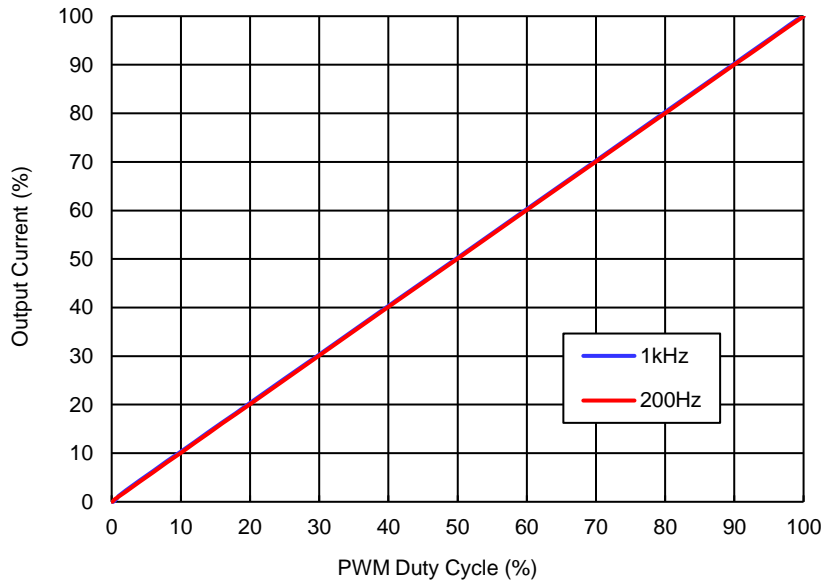

Figure 9 PWM Dimming Curve with PMOS Driving on Output on Buck-Boost

Application Information (continued)

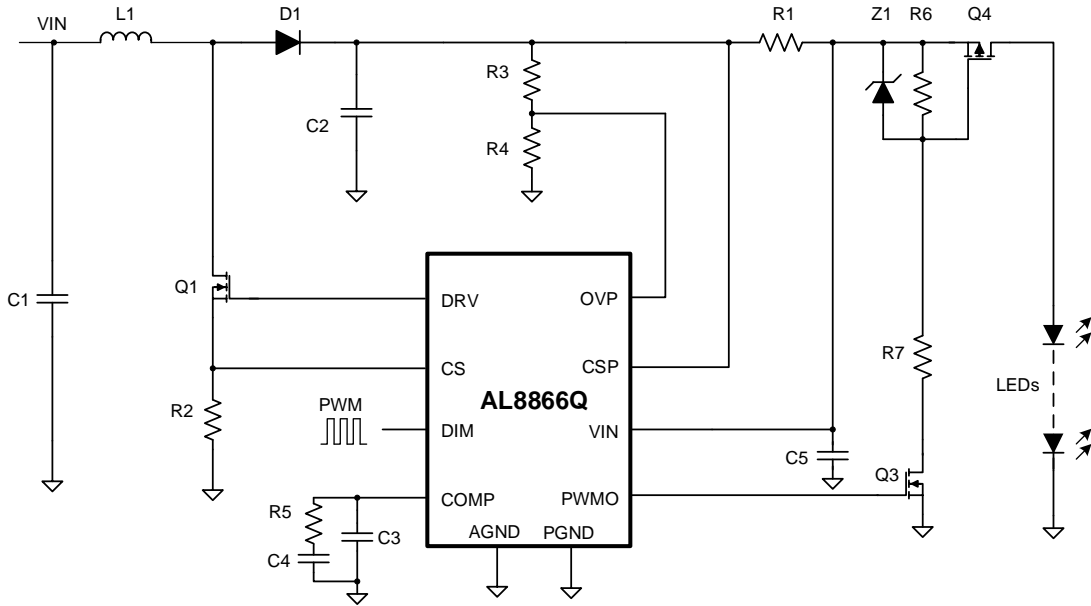

Figure 10 Boost LED Driver with PWM Dimming Operation

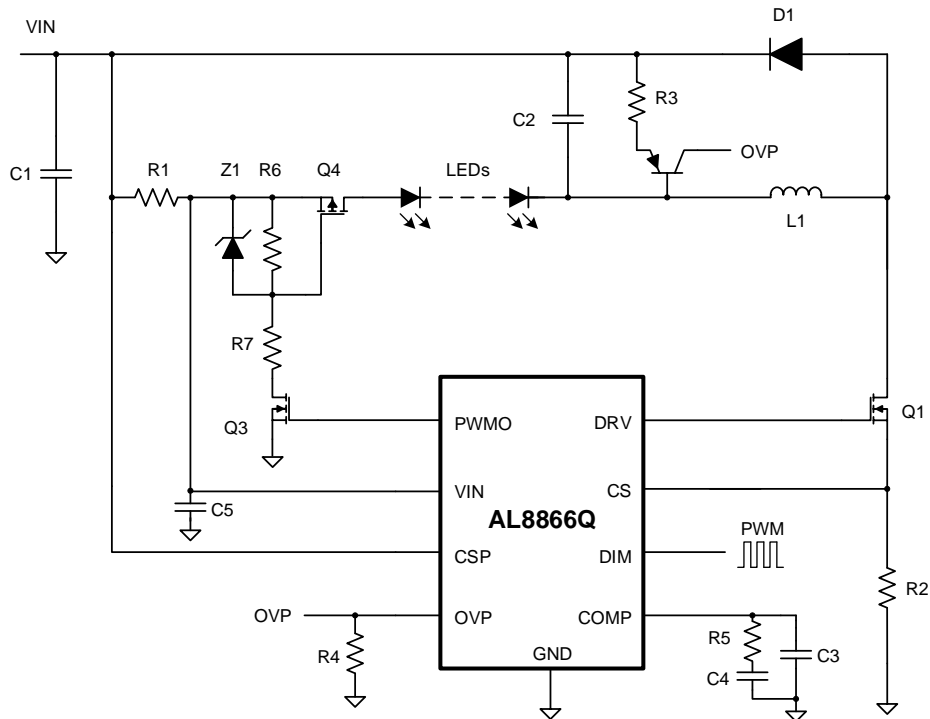

Figure 11 Buck LED Driver with PWM Dimming Operation

Application Information (continued)

Analog Dimming

The LED current can be linearly adjusted from 0 to 100% by varying the voltage at DIM pin from 0.3V to 2.5V.

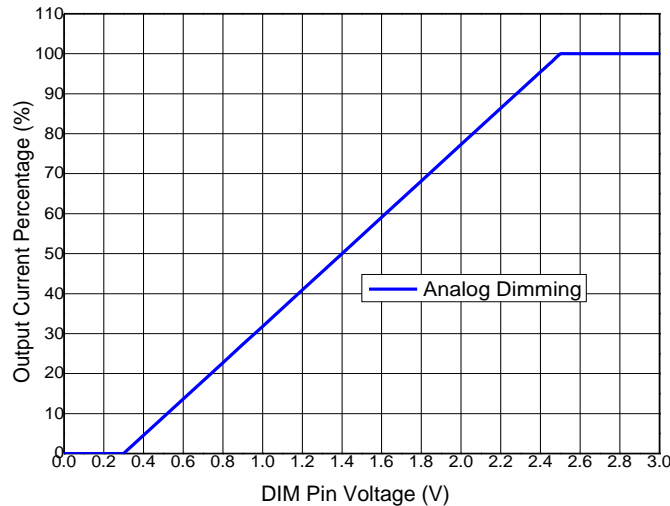

Figure 12 Analog Dimming Curve

Soft-Start

Soft-start can be provided via the analog dimming signal at DIM pin. The soft-start period can be programmed by the selection of appropriate capacitor between DIM pin and GND according to the following formula. The internal 30μA current source gradually increases the voltage on an external soft-start capacitor connected to the DIM pin. The default soft-start time is 11ms if no capacitor connected on DIM pin.

$$C_{soft} = \frac{t_{soft} \times 30 \times 10^{-6}}{2.5}$$

Protections

VIN Undervoltage Lockout (UVLO)

The AL8866Q monitors the voltage on VIN pin to implement UVLO protection. Operation is enabled when V_{VIN} exceeds 4.5V (typ) and is disabled when V_{VIN} drops below 4.2V (typ). The 300mV hysteresis is added on UVLO comparator to avoid chatter during transient. The UVLO threshold is fixed internal and cannot be adjusted. The VIN supply powers the internal circuitry. Place a bypass capacitor across the VIN and GND to ensure proper operation.

Output Overvoltage Protection (OVP) and LED Open-Circuit Protection

To prevent components damaged, the AL8866Q features output overvoltage protection. When LED string is open, the output voltage and V_{OVP} will increase immediately. The AL8866Q would enter hiccup mode once V_{OVP} exceed 2V. For different topology, customers need to select the suitable LED voltage sense circuitry. For Boost/SEPIC topologies, the output LED string cathode end is connected to ground, so designer could use simply resistor divider to sense the output LED voltage, as shown in Figure 2 & Figure 4.

$$V_{OVP} \approx \frac{R_4}{R_3 + R_4} \times (V_{LED} + V_{SNS})$$

For Buck-Boost and Buck application, the LED string cathode end is not connected to ground. Use an additional sensing circuit in Figure 8 and Figure 11 to sense LED string voltage accurately. The voltage on OVP pin in LED open status is calculated by following formula:

$$V_{OVP} \approx \frac{R_4}{R_3} \times (V_{LED} + V_{SNS} - V_{EB})$$

Where V_{EB} is the voltage between the emitter and base of bipolar.

To simplify circuit design, using a resistor divider to sense LED voltage roughly is acceptable if input voltage range is not too large on Buck-Boost topology shown in Figure 1.

$$V_{OVP} \approx \frac{R_4}{R_3 + R_4} \times (V_{IN} + V_{LED} + V_{SNS})$$

For Buck topology shown in Figure 3, use the following formula below to calculate the voltage on OVP pin.

$$V_{OVP} \approx \frac{R_4}{R_3 + R_4} \times (V_{IN} - V_{LED} - V_{SNS})$$

Application Information (continued)

Output Overvoltage Protection (OVP) and LED Open-Circuit Protection (continued)

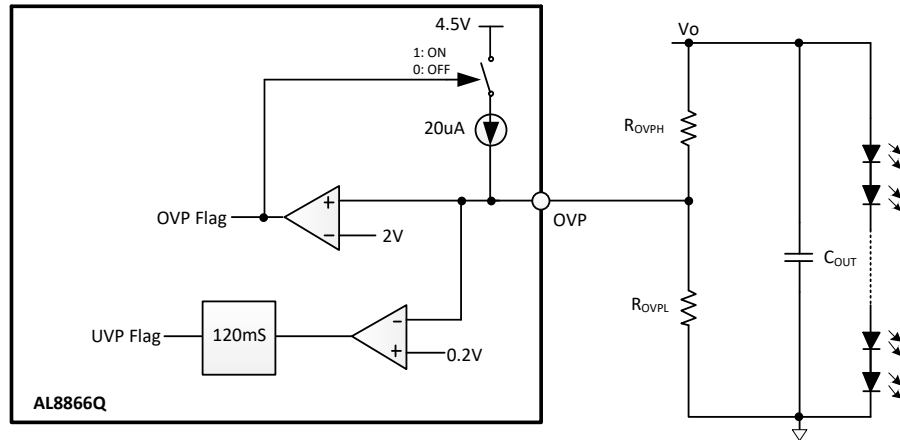

Figure 13 Output Overvoltage Detection Circuit

If V_{OVP} is higher than 2V, output overvoltage fault is detected and device enters Overvoltage Protection (OVP). The device is shutting down and the COMP capacitor is discharged, the FLT pin voltage is pulled to low level. When OVP is triggered, a $20\mu A$ current source goes through the resistor R_{OVPL} between OVP pin and GND, then V_{OVP} equals to 2V plus the hysteresis V_{HYS_OVP} .

$$V_{HYS_OVP} = 20\mu A \times R_{OVPL}$$

If error is removed and V_{OVP} is lower than 2V, the internal comparator output turns to low, and the OVP flag is released, meanwhile a soft-start sequence is initiated to restart the device.

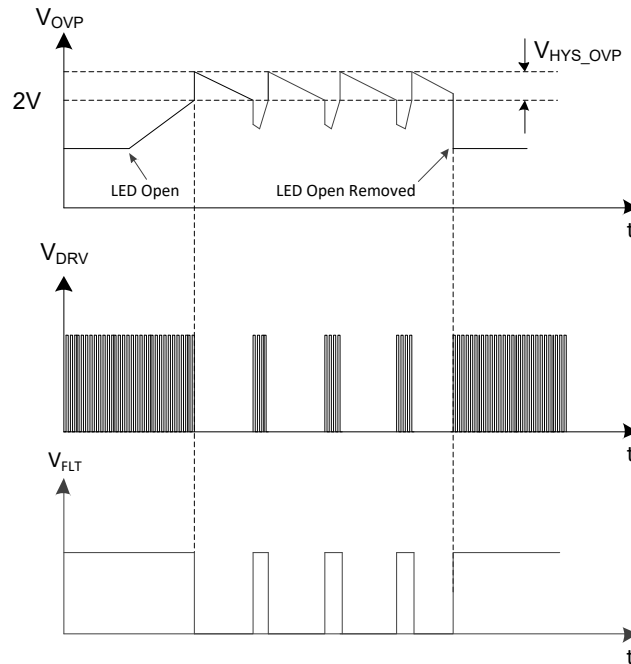

Figure 14 Output Overvoltage Protection

Application Information (continued)

Output Undervoltage Protection (UVP) and LED String Short-Circuit Protection

The AL8866Q features output LED short-circuit protection. When LED string (LED+ to LED-) is shorted, the voltage on output capacitor decreases rapidly. Meanwhile V_{OVP} decreases correspondingly. The voltage drop on output current sense resistor R_{LED} exceeds 0.36V, the output short condition is detected.

Once output short-circuit is detected, switching driver is shut-down; the device enters in hiccup mode. After 30ms, the device restarts to check if the short condition is removed. If the short condition still exists, V_{LED} should be very low. If V_{OVP} is lower than 0.2V for 60ms, the output Undervoltage Protection (UVP) is detected, and the device stops switching.

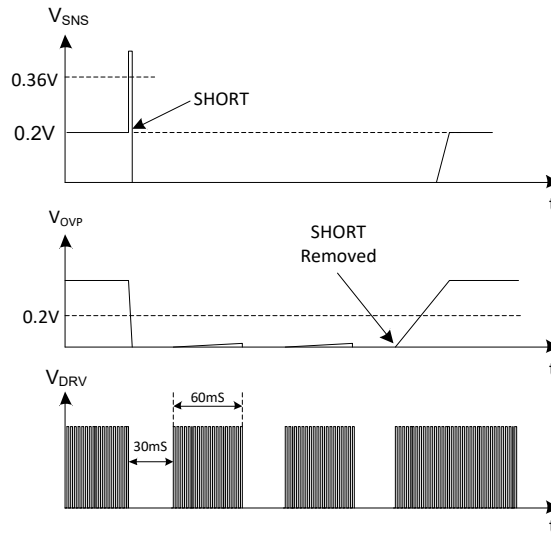

Figure 15 Output Short-Circuit Protection

Switching Current Limitation

The AL8866Q supports cycle-by-cycle current limit to prevent power switch from damage. The CS pin monitors the current going through power switch. Cycle-by-cycle current limit is accomplished by two internal comparators. After 100ns (typical) Leading Edge Blanking (LEB) time, if V_{CS} exceeds 0.5V in 16 switching cycles continuously, the switching overcurrent is detected. Another current limit comparator has 1.2V typical threshold. In any switching cycle, once V_{CS} exceeds 1.2V, the device terminates the switching to end this cycle immediately. If 1.2V-Current Limit is triggered for 16 switching cycle, the switching overcurrent is detected.

When a switching overcurrent fault is detected, the device turns off switching output, and the V_{FLT} is pulled down to low. System enters in hiccup mode. After 30ms turn off time, the system restarts to operate with soft-start sequence.

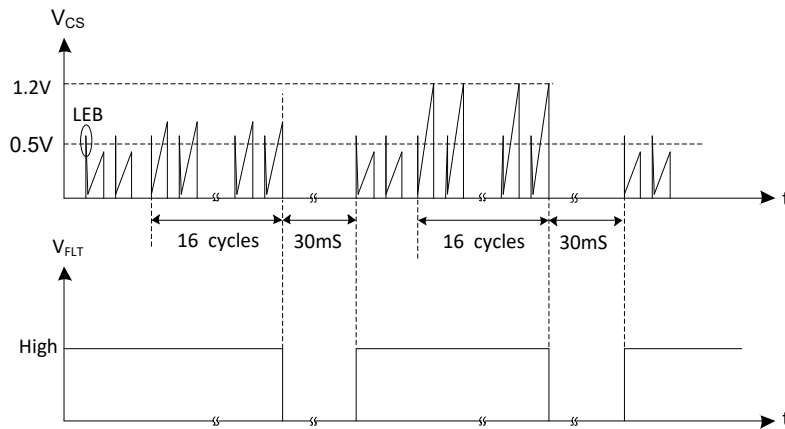

Figure 16 Switching Current Limit

Application Information (continued)

Sense Resistor Short-Circuit Protection

In single fault test, the sense resistor would be short. In this fault condition, the output current is set to a very large value. The current through inductor also increases significantly. When V_{CS} exceeds 0.5V for 16 cycles, the switching over current fault is detected, the device turns off switching to enter in hiccup mode.

Diode/Inductor Short-Circuit Protection

Once the main diode or inductor is short, the V_{CS} increases quickly to exceed 1.2V, and this situation V_{CS} pulse lasts for 16 switching cycle, the OCP protection is triggered. System enters hiccup mode to protect the device and power components.

Diode Open-Circuit Protection

The output capacitor discharges and the output voltage decreases while the diode is open. Once the V_{OVP} is lower than 0.2V, the output under voltage protection is triggered. System enters hiccup mode to protect the device and power components.

Thermal Shutdown Protection

Internal thermal shutdown circuitry is implemented to protect the controller in the event the maximum junction temperature is exceeded. When activated, typically at +170°C, the controller is forced into a shutdown mode, disabling the internal regulator. Once the device temperature is down to +145°C (typ +25°C hysteresis), the fault is cleared and restarts to switching. This feature is designed to prevent overheating and damage to the device.

Fault Indicator

The AL8866Q includes an open-drain output to indicate fault conditions. Designer could directly tie FLT to GPIO of micro controller or connects to input DC source via a resistor.

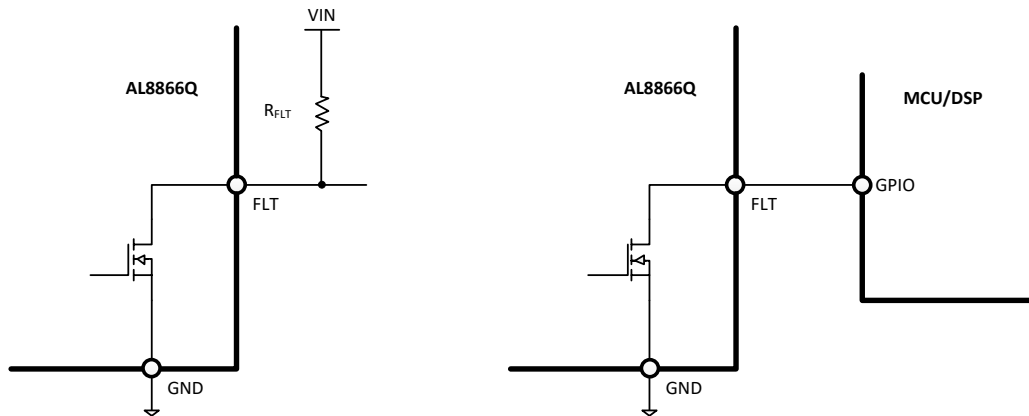

Figure 17 FLT Pin Interface Connection

Application Information (continued)

The FLT pin goes low under the following conditions:

- Output overvoltage protection / LED open-circuit protection
- Output undervoltage protection/ LED short-circuit protection
- Cycle-by-cycle current limitation
- Sense resistor short-circuit protection
- Diode/inductor short-circuit protection
- Diode open-circuit protection
- Thermal shutdown protection

Protection	Detection	FLT Status	Action
Input Undervoltage (UVLO)	$V_{VIN} < 4V$	High	VIN UVLO rising 4V with 0.4V hysteresis. FLT pin remains in high impedance state.
Cycle by Cycle Current Limit	$V_{CS} > 500mV$	Low	When fault occurs, cycle-by-cycle current limit operates. If fault > 16 switching cycles, the device is shutdown, the FLT pin is forced to low level, and enter hiccup period, then auto-restart.
Thermal Protection	$T_J > +170^{\circ}C$	Low	The device is forced into a shutdown mode, and the FLT pin is forced to low level. A startup sequence is initiated when the junction temperature falls below +145°C.
Output Overvoltage Protection/ LED Open-Circuit Protection	$V_{OVP} > 2V$	Low	If the voltage at OVP pin is higher than 2V, the device is shut down and the COMP capacitor is discharged. The FLT pin is forced to low level. Meanwhile a 20μA current source on OVP pin is activated and go through external resistor on OVP pin. At this time the voltage on OVP pin equals to sum of 2V and voltage drop on external resistor on OVP pin. Soft-start sequence is initiated once the voltage on OVP pin drops below 2V.
Output Undervoltage Protection/ LED Short-Circuit Protection/ Diode Open-Circuit Protection	$V_{CSP} - V_{VIN} > 360mV$ $V_{OVP} < 200mV$	Low	When the voltage gap between CSP and VIN pin exceeds 360mV, the output over current protection will be triggered. When OV pin voltage drops below 200mV, the device is shut down; the FLT pin is forced to low level, and enter hiccup period, then auto-restart.
Sense Resistor Short-Circuit Protection	$V_{CS} > 500mV$ after LEB accumulated 16 switching cycles	Low	When the chip gate drive signal changes from low to high level, an internal comparator starts detecting the CS signal after leading edge blanking (LEB) time. When CS voltage exceeds 0.5V, the chip will immediately end the current gate drive and increment a counter. When the accumulates time in the counter reaches 16, this protection is triggered. The FLT pin is forced to low level, and enter hiccup period, then auto-restart.
Diode/Inductor Short-Circuit Protection	$V_{CS} > 1.2V$ accumulated 16 switching cycles	Low	When the chip gate drive signal changes from low to high level, an internal comparator starts detecting the CS signal. When CS voltage exceeds 1.2V, the chip will immediately end the current gate drive and increment a counter. When the accumulates time in the counter reaches 16, this protection is triggered. The FLT pin is forced to low level, and enter hiccup period, then auto-restart.

Application Information (continued)

Duty Cycle Considerations

The switch duty cycle, D , defines the converter operation and is a function of the input and output voltages. In steady state, the duty cycle is derived using expression:

- Boost:

$$D = \frac{V_O - V_{IN}}{V_O}$$

- Buck-Boost:

$$D = \frac{V_O}{V_O + V_{IN}}$$

- Buck:

$$D = \frac{V_O}{V_{IN}}$$

The minimum duty cycle, D_{MIN} , and maximum duty cycle, D_{MAX} , are calculated by substituting maximum input voltage, $V_{IN(MAX)}$, and the minimum input voltage, $V_{IN(MIN)}$, respectively in the previous expressions. The minimum duty cycle achievable by the device is determined by the leading edge blanking period and the switching frequency. The maximum duty cycle is limited by the internal oscillator to 95% (typ) to allow for minimum off-time. It is necessary for the operating duty cycle to be within the operating limits.

Inductor Selection

The choice of inductor sets the continuous conduction mode (CCM) and discontinuous conduction mode (DCM) boundary condition. Therefore, one approach of selecting the inductor value is by deriving the relationship between the output power corresponding to CCM-DCM boundary condition, $P_{O(BDRY)}$ and inductance, L . This approach ensures CCM operation in battery-powered LED driver applications that are required to support different LED string configurations with a wide range of programmable LED current set points. The CCM-DCM boundary condition can be estimated either based on the lowest LED current and the lowest output voltage requirements for a given application or as a fraction of maximum output power, $P_{O(MAX)}$.

$$P_{O(BDRY)} < I_{LED(MIN)} \times V_{O(MIN)}$$

$$\frac{P_{O(MAX)}}{4} \leq P_{O(BDRY)} \leq \frac{P_{O(MAX)}}{2}$$

- Boost:

$$L = \frac{V_{IN(MAX)}^2}{2 \times P_{O(BDRY)} \times f_{sw}} \times \left(1 - \frac{V_{IN(MAX)}}{V_{O(MAX)}}\right)$$

- Buck-Boost:

$$L = \frac{1}{2 \times P_{O(BDRY)} \times f_{sw} \times \left(\frac{1}{V_{O(MAX)}} + \frac{1}{V_{IN(MAX)}}\right)^2}$$

- Buck:

$$L = \frac{(V_{IN(MAX)} - V_{O(MAX)})^2}{2 \times P_{O(BDRY)} \times f_{sw}} \times \left(\frac{V_{O(MAX)}}{V_{IN(MAX)}}\right)^2$$

Select inductor with saturation current rating greater than the peak inductor current, I_{PK} , at the maximum operating temperature.

- Boost:

$$I_{PK} = \frac{P_{O(MAX)}}{V_{IN(MIN)}} + \frac{V_{IN(MIN)}}{2 \times L \times f_{sw} \times V_{O(MAX)}} \times \left(1 - \frac{V_{IN(MIN)}}{V_{O(MAX)}}\right)$$

- Buck-Boost:

$$I_{PK} = P_{O(MAX)} \times \left(\frac{1}{V_{O(MIN)}} + \frac{1}{V_{IN(MIN)}}\right) + \frac{V_{O(MIN)} \times V_{IN(MIN)}}{2 \times L \times f_{sw} \times (V_{O(MIN)} + V_{IN(MIN)})}$$

Application Information (continued)

Inductor Selection (continued)

- Buck:

$$I_{PK} = I_{O(MAX)} \times \frac{V_{IN(MIN)}}{V_{IN(MIN)} - V_{O(MAX)}} + \frac{(V_{IN(MIN)} - V_{O(MAX)}) \times V_{O(MAX)}}{2 \times L \times f_{sw} \times V_{IN(MIN)}}$$

Output Capacitor Selection

The output capacitors are required to attenuate the discontinuous or large ripple current generated by switching and achieve the desired peak-to-peak LED current ripple, $\Delta i_{LED(PP)}$. The capacitor value depends on the total series resistance of the LED string, r_D and the switching frequency, f_{sw} . The capacitance required for the target LED ripple current can be calculated based on following equations.

- Boost and Buck:

$$C_{OUT} = \frac{P_{O(MAX)}}{\Delta i_{LED(PP)} \times r_{D(MIN)} \times f_{sw} \times V_{O(MAX)}} \times \left(1 - \frac{V_{IN(MIN)}}{V_{O(MAX)}}\right)$$

- Buck-Boost:

$$C_{OUT} = \frac{P_{O(MAX)}}{\Delta i_{LED(PP)} \times r_{D(MIN)} \times f_{sw} \times (V_{O(MIN)} + V_{IN(MIN)})}$$

When choosing the output capacitors, it is important to consider the ESR and the ESL characteristics as they directly impact the LED current ripple. Ceramic capacitors are the best choice due to their low ESR, high ripple current rating, long lifetime, and good temperature performance. When selecting ceramic capacitors, it is important to consider the derating factors associated with higher temperature and DC bias operating conditions. DIODES recommends an X7R dielectric with voltage rating greater than maximum LED stack voltage. An aluminum electrolytic capacitor can be used in parallel with ceramic capacitors to provide bulk energy storage. The aluminum capacitors must have necessary RMS current and temperature ratings to ensure prolonged operating lifetime. The minimum allowable RMS output capacitor current rating, $I_{COUT(RMS)}$, can be approximated:

- Boost and Buck-Boost:

$$I_{COUT(RMS)} = I_{LED} \times \sqrt{\frac{D_{MAX}}{1 - D_{MAX}}}$$

- Buck:

$$I_{COUT(RMS)} = \frac{V_{IN(MIN)} - V_{O(MAX)}}{\sqrt{12} \times L \times f_{sw}} \times D_{MAX}$$

Input Capacitor Selection

The input capacitors, C_{IN} , smooth the input voltage ripple and store energy to supply input current during input voltage or PWM dimming transients. The series inductor in the Boost and SEPIC topologies provides continuous input current and requires a smaller input capacitor to achieve desired input ripple voltage, $\Delta V_{IN(PP)}$. The Buck-Boost topology has discontinuous input current and require a larger capacitor to achieve the same input voltage ripple. Based on the switching frequency, f_{sw} , and the maximum duty cycle, D_{MAX} , the input capacitor value can be calculated as follows:

- Boost:

$$C_{IN} = \frac{V_{IN(MIN)}}{8 \times L \times f_{sw}^2 \times \Delta V_{IN(PP)}} \times \left(1 - \frac{V_{IN(MIN)}}{V_{O(MAX)}}\right)$$

- Buck-Boost:

$$C_{IN} = \frac{P_{O(MAX)}}{f_{sw} \times \Delta V_{IN(PP)} \times (V_{O(MAX)} + V_{IN(MIN)})}$$

- Buck:

$$C_{OUT} = \frac{P_{O(MAX)}}{f_{sw} \times \Delta V_{IN(PP)} \times (V_{O(MAX)} + V_{IN(MIN)})} \times \left(1 - \frac{V_{O(MAX)}}{V_{IN(MIN)}}\right)$$

X7R dielectric-based ceramic capacitors are the best choice due to their low ESR, high ripple current rating, and good temperature performance. For applications using PWM dimming, recommends an aluminum electrolytic capacitor in addition to ceramic capacitors to minimize the voltage deviation due to large input current transients generated in conjunction with the rising and falling edges of the LED current.

Application Information (continued)

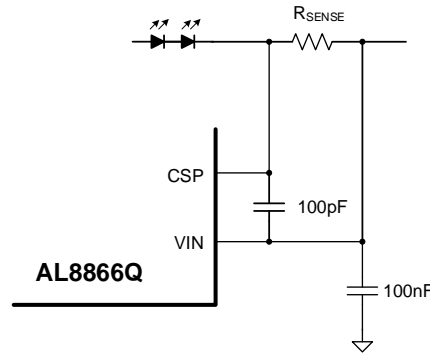

Figure 18 VIN and CSP Input Filter

Decouple VIN pin with a 0.1µF ceramic capacitor, placed as close as possible to the device and a series 10Ω resistor to create a 150kHz low-pass filter.

Main Power MOSFET Selection

The power MOSFET is required to sustain the maximum switch node voltage, V_{SW} , and switch RMS current derived based on the converter topology. TI recommends a drain voltage V_{DS} rating of at least 10% greater than the maximum switch node voltage to ensure safe operation. The MOSFET drain-to-source breakdown voltage, V_{DS} , is calculated using the following expressions.

- Boost:

$$V_{DS} = 1.1 \times V_{O(OV)}$$

- Buck-Boost:

$$V_{DS} = 1.1 \times (V_{O(OV)} + V_{IN(MAX)})$$

- Buck:

$$V_{DS} = 1.1 \times V_{IN(MAX)}$$

The voltage, $V_{O(OV)}$, is the overvoltage protection threshold and the worst-case output voltage under fault conditions. The worst case MOSFET RMS current for Boost and Buck-Boost topology is dependent on maximum output power, $P_{O(MAX)}$, and is calculated as follows:

- Boost & Buck-Boost:

$$I_{Q(RMS)} = \frac{P_{O(MAX)}}{V_{IN(MIN)}} \times \sqrt{1 + \frac{V_{IN(MIN)}}{V_{O(MIN)}}}$$

- Buck:

$$I_{Q(RMS)} = \frac{P_{O(MAX)}}{V_{IN(MIN)}} \times \sqrt{1 + \frac{V_{IN(MIN)}}{V_{O(MIN)}}} \times (1 - \frac{V_{O(MIN)}}{V_{IN(MIN)}})$$

Select a MOSFET with low total gate charge, Q_g , to minimize gate drive and switching losses. The MOSFET $R_{DS(ON)}$ resistance is usually a less critical parameter because the switch conduction losses are not a significant part of the total converter losses at high operating frequencies. The switching and conduction losses are calculated as follows:

$$P_{Cond} = R_{DS(ON)} \times I_{Q(RMS)}^2$$

$$P_{SW} = \frac{I_L \times V_{SW}^2 \times C_{rSS} \times f_{SW}}{I_{GATE}}$$

$$P_{MOS_TOTAL} = P_{Cond} + P_{SW}$$

C_{rSS} is the MOSFET reverse transfer capacitance. I_L is the average inductor current. I_{GATE} is gate drive output current, typically 500mA. The MOSFET power rating and package is selected based on the total calculated loss, the ambient operating temperature, and maximum allowable temperature rise.

Application Information (continued)

Switch Current Sense Resistor

The switch current sense resistor, R_{CS} , is used to implement peak current mode control and to set the peak switch current limit. The value of R_{CS} is selected to protect the main switching MOSFET under fault conditions. The R_{CS} can be calculated based on peak inductor current, $i_{L(PK)}$, and switch current limit threshold, V_{CS_LIMIT1} which is 0.5V typical.

$$R_{CS} = \frac{V_{CS_LIMIT1}}{i_{L_PK}}$$

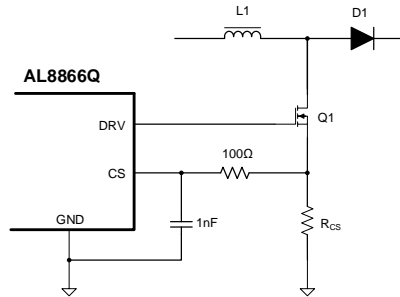

Figure 19 MOSFET Current Sense Input Filter

Feedback Compensation

The open-loop response is the product of the modulator transfer function and the feedback transfer function. Using a first-order approximation, the modulator transfer function can be modeled as a single pole created by the output capacitor, and in the boost and buck-boost topologies, a right half-plane zero created by the inductor, where both have a dependence on the LED string dynamic resistance, r_D . The ESR of the output capacitor is neglected in the analysis. The small-signal modulator model also includes a DC gain factor that is dependent on the duty cycle, output voltage, and LED current.

- Boost & Buck-Boost:

$$\frac{\hat{i}_{LED}}{\hat{v}_{COMP}} = G_0 \times \frac{1 - \frac{s}{\omega_z}}{1 + \frac{s}{\omega_p}}$$

- Buck:

$$\frac{\hat{i}_{LED}}{\hat{v}_{COMP}} = G_0 \times \frac{1}{1 + \frac{s}{\omega_p}}$$

The Table listed below summarizes the expression for the small-signal model parameters.

Small-Signal Model Parameters

Topology	DC Gain (G_0)	Pole Frequency (ω_p)	Zero Frequency (ω_z)
Boost	$\frac{(1 - D) \times V_o}{R_{CS} \times (V_o + r_D \times I_{LED})}$	$\frac{V_o + r_D \times I_{LED}}{V_o \times r_D \times C_{OUT}}$	$\frac{V_o \times (1 - D)^2}{L \times I_{LED}}$
Buck-Boost	$\frac{(1 - D) \times V_o}{R_{CS} \times (V_o + D \times r_D \times I_{LED})}$	$\frac{V_o + D \times r_D \times I_{LED}}{V_o \times r_D \times C_{OUT}}$	$\frac{V_o \times (1 - D)^2}{D \times L \times I_{LED}}$
Buck	$\frac{V_o}{R_{CS} \times r_D \times I_{LED}}$	$\frac{1}{r_D \times C_{OUT}}$	—

The feedback transfer function includes the current sense resistor and the loop compensation of the transconductance amplifier. A compensation network at the output of the error amplifier is used to configure loop gain and phase characteristics. A simple capacitor, C_{COMP} , from COMP to GND (as shown in Figure 20) provides integral compensation and creates a pole at the origin. Alternatively, a network of R_{COMP} , C_{COMP} , and C_{HF} , shown in Figure 21, can be used to implement proportional and integral (PI) compensation to create a pole at the origin, a low-frequency zero, and a high-frequency pole.

Application Information (continued)

The feedback transfer function is defined as follows.

Feedback transfer function with integral compensation:

$$\frac{\hat{v}_{COMP}}{\hat{i}_{LED}} = \frac{11 \times g_M \times R_{SENSE}}{s \times C_{COMP}}$$

Feedback transfer function with proportional integral compensation:

$$\frac{\hat{v}_{COMP}}{\hat{i}_{LED}} = \frac{11 \times g_M \times R_{SENSE}}{s \times (C_{COMP} + C_{HF})} \times \frac{1 + s \times R_{COMP} \times C_{COMP}}{1 + s \times R_{COMP} \times \frac{C_{COMP} \times C_{HF}}{C_{COMP} + C_{HF}}}$$

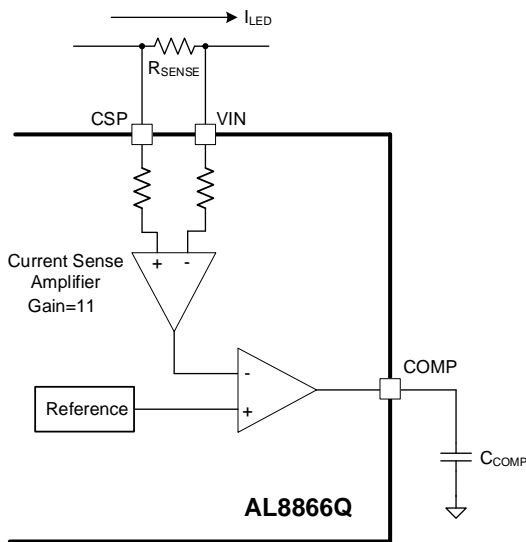

Figure 20 Integral Compensator

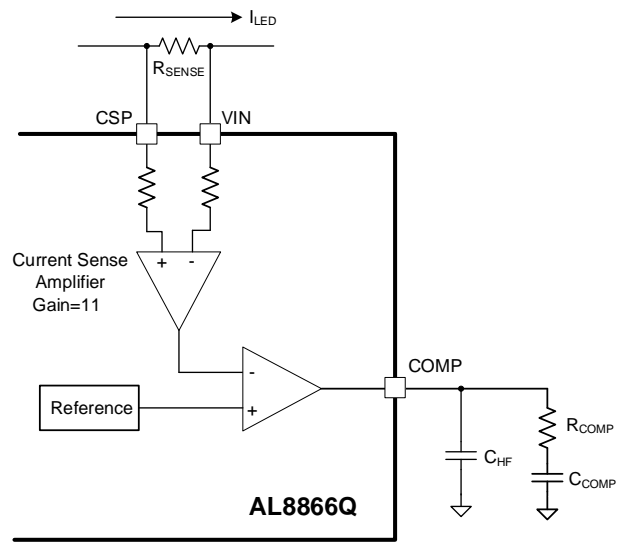

Figure 21 Proportional Integral Compensator

Boost and Buck-Boost with integral compensator:

$$C_{COMP} = \frac{8.75 \times 10^{-3} \times R_{SENSE}}{\omega_p}$$

Boost and Buck-Boost with proportional integral compensator:

$$C_{COMP} = 8.75 \times 10^{-3} \times \frac{R_{SENSE} \times G_0}{\omega_z}$$

$$C_{HF} = \frac{C_{COMP}}{100}$$

$$R_{COMP} = \frac{1}{\omega_p \times C_{COMP}}$$

The loop response is verified by applying step input voltage transients. The goal is to minimize LED current overshoot and undershoot with a damped response. Additional tuning of the compensation network may be necessary to optimize PWM dimming performance.

Layout

PCB Layout

1. The AL8866Q is a high switching frequency converter. Hence, attention must be paid to the switching currents interference in the layout. Switching current from one power device to another can generate voltage transients across the impedances of the interconnecting bond wires and circuit traces. These interconnecting impedances should be minimized by using wide, short printed circuit traces. If the AL8866Q works at high power output condition, remarkable heat dissipation is a major concern in the layout of the PCB. 2oz copper for both the top and bottom layers is recommended. Four layers PCB is recommended to minimize ground noise.
2. Place the decoupling capacitor as closely across VIN and GND as possible.
3. Place the inductor as close to MOSFET drain node as possible.
4. Place the output capacitors as close to VIN/GND as possible for Buck-Boost/Boost.
5. The copper trace between the LED current sense resistor and the VIN & CSP pins should be kept parallel and the enclosed area should be minimized as much as possible.
6. Add as many vias as possible around both the GND pin and under the GND plane for heat dissipation to all the GND layers.
7. See Figure 22 for more details.

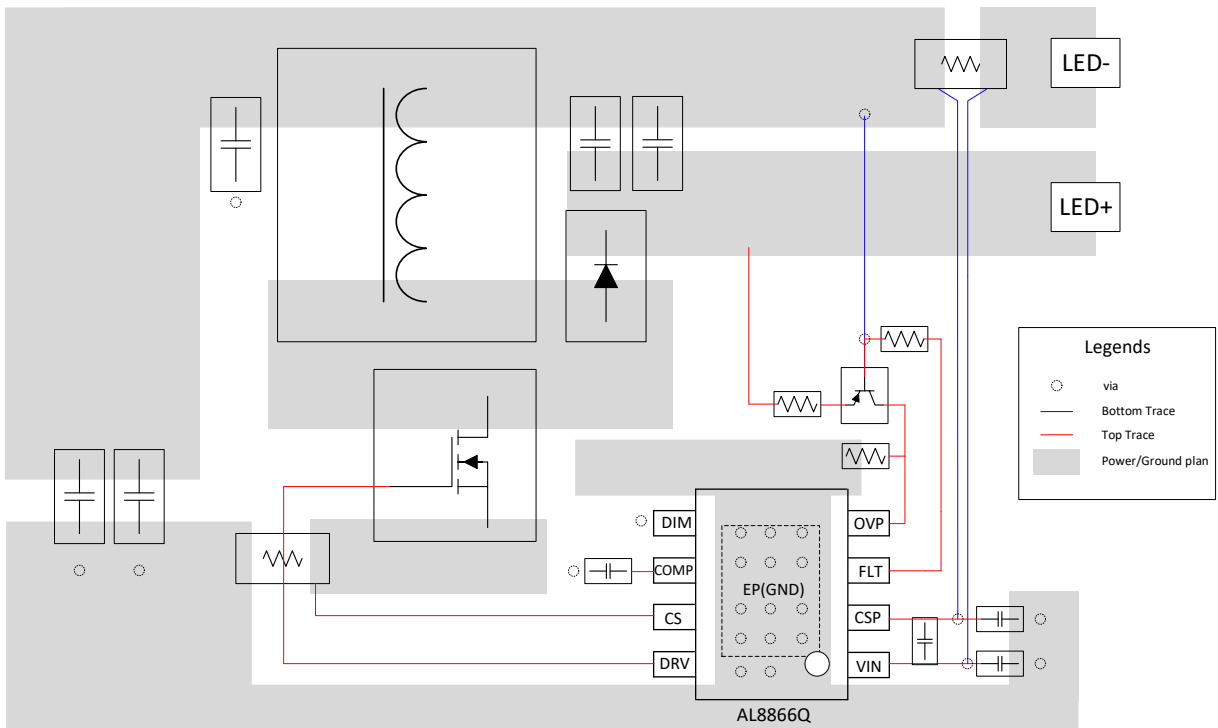

Figure 22 Recommend PCB Layout

Design Tools (Note 8)

- AL8866Q Demo Boards
- AL8866Q Calculator
- Demo Board Gerber File for PCB Layout Reference

Note: 8. Diodes Incorporated's design tools can be found on our website at <https://www.diodes.com/design/tools/>.

Ordering Information

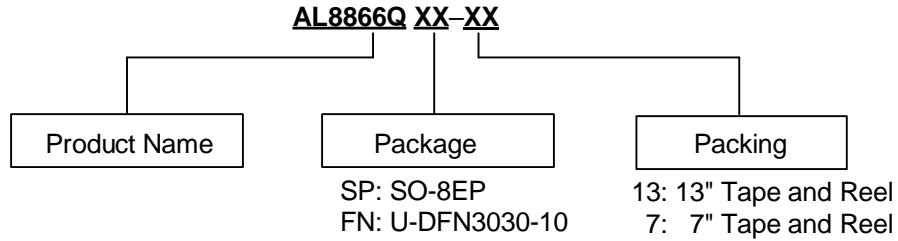

Orderable Part Number	Package Code	Package	Packing	
			Qty.	Carrier
AL8866QSP-13	SP	SO-8EP	2500	13" Tape & Reel
AL8866QFN-7	FN	U-DFN3030-10	1500	7" Tape & Reel

Marking Information

SO-8EP

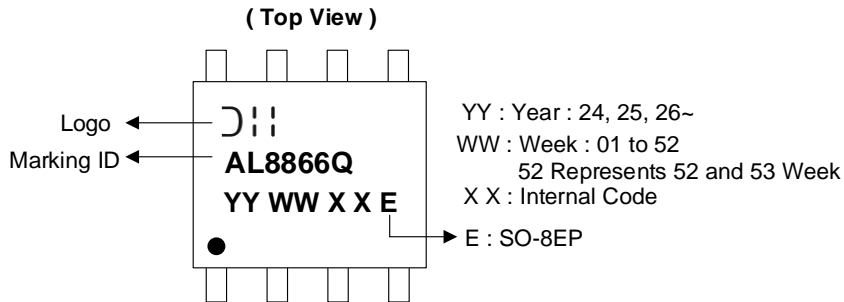

U-DFN3030-10

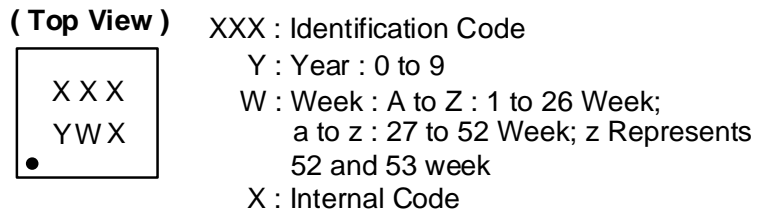

Orderable Part Number	Package	Identification Code
AL8866QFN-7	U-DFN3030-10	PPQ

Package Outline Dimensions (Note 9)

Please see <http://www.diodes.com/package-outlines.html> for the latest version.

SO-8EP

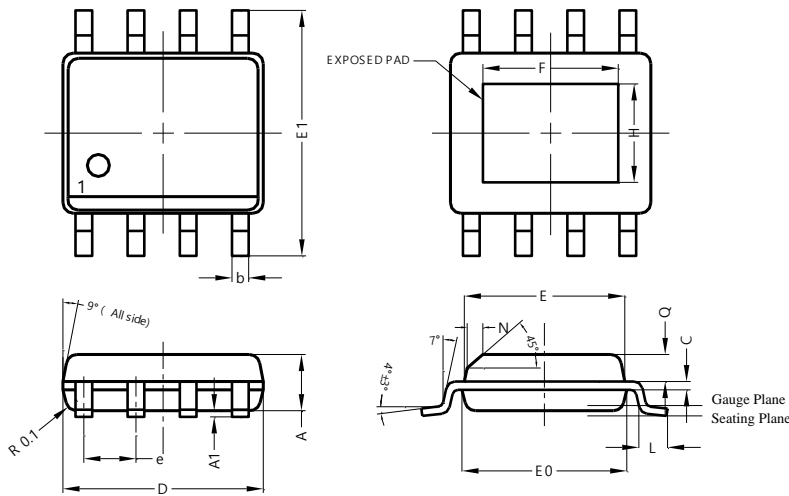

SO-8EP			
Dim	Min	Max	Typ
A	1.40	1.50	1.45
A1	0.00	0.13	-
b	0.30	0.50	0.40
C	0.15	0.25	0.20
D	4.85	4.95	4.90
E	3.80	3.90	3.85
E0	3.85	3.95	3.90
E1	5.90	6.10	6.00
e	-	-	1.27
F	2.75	3.35	3.05
H	2.11	2.71	2.41
L	0.62	0.82	0.72
N	-	-	0.35
Q	0.60	0.70	0.65
All Dimensions in mm			

U-DFN3030-10

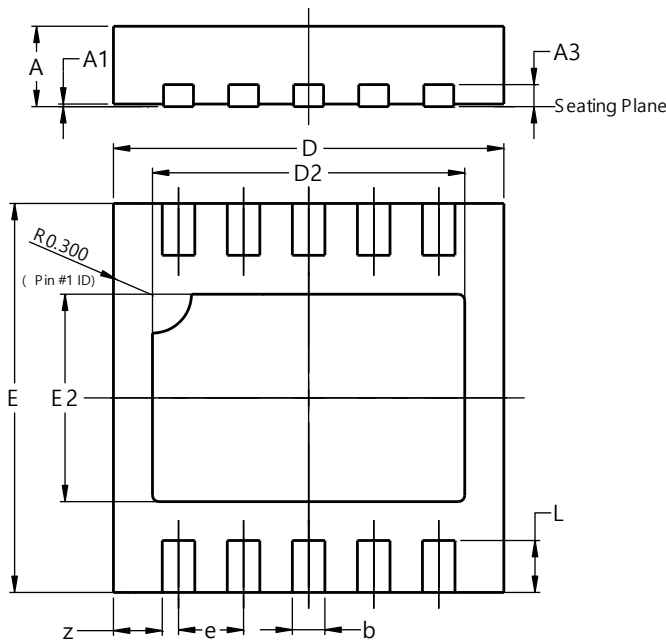

U-DFN3030-10			
Dim	Min	Max	Typ
A	0.57	0.63	0.60
A1	0.00	0.05	0.02
A3	—	—	0.15
b	0.20	0.30	0.25
D	2.90	3.10	3.00
D2	2.30	2.50	2.40
E	2.90	3.10	3.00
E2	1.50	1.70	1.60
e	--	--	0.50
L	0.25	0.55	0.40
z	—	—	0.375
All Dimensions in mm			

Note: 9. Please see <https://www.diodes.com/assets/Packaging-Support-Docs/AP02007.pdf> for tape and reel information.

Suggested Pad Layout

Please see <http://www.diodes.com/package-outlines.html> for the latest version.

SO-8EP

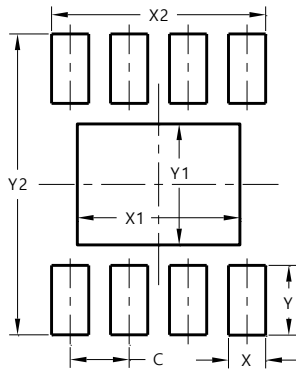

Dimensions	Value (in mm)
C	1.270
X	0.802
X1	3.502
X2	4.612
Y	1.505
Y1	2.613
Y2	6.500

U-DFN3030-10

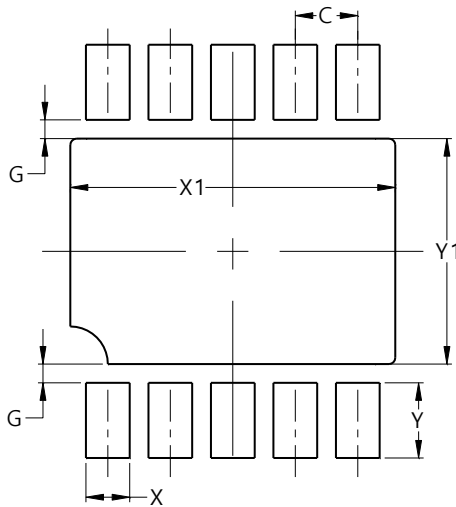

Dimensions	Value (in mm)
C	0.50
G	0.15
X	0.35
X1	2.60
Y	0.60
Y1	1.80

Mechanical Data

SO-8EP:

- Moisture Sensitivity: MSL Level 1 per JESD22-A113
- Terminals: Finish - Matte Tin Plated Leads, Solderable per M2003 JESD22-B102 ⑥③
- Weight: 0.077 grams (Approximate)

U-DFN3030-10:

- Moisture Sensitivity: MSL Level 1 per JESD22-A113
- Terminals: Finish - Matte NiPdAu Plated Leads, Solderable per M2003 JESD22-B102 ⑥③
- Weight: 0.017 grams (Approximate)

IMPORTANT NOTICE

1. DIODES INCORPORATED (Diodes) AND ITS SUBSIDIARIES MAKE NO WARRANTY OF ANY KIND, EXPRESS OR IMPLIED, WITH REGARDS TO ANY INFORMATION CONTAINED IN THIS DOCUMENT, INCLUDING, BUT NOT LIMITED TO, THE IMPLIED WARRANTIES OF MERCHANTABILITY, FITNESS FOR A PARTICULAR PURPOSE OR NON-INFRINGEMENT OF THIRD PARTY INTELLECTUAL PROPERTY RIGHTS (AND THEIR EQUIVALENTS UNDER THE LAWS OF ANY JURISDICTION).
2. The Information contained herein is for informational purpose only and is provided only to illustrate the operation of Diodes' products described herein and application examples. Diodes does not assume any liability arising out of the application or use of this document or any product described herein. This document is intended for skilled and technically trained engineering customers and users who design with Diodes' products. Diodes' products may be used to facilitate safety-related applications; however, in all instances customers and users are responsible for (a) selecting the appropriate Diodes products for their applications, (b) evaluating the suitability of Diodes' products for their intended applications, (c) ensuring their applications, which incorporate Diodes' products, comply the applicable legal and regulatory requirements as well as safety and functional-safety related standards, and (d) ensuring they design with appropriate safeguards (including testing, validation, quality control techniques, redundancy, malfunction prevention, and appropriate treatment for aging degradation) to minimize the risks associated with their applications.
3. Diodes assumes no liability for any application-related information, support, assistance or feedback that may be provided by Diodes from time to time. Any customer or user of this document or products described herein will assume all risks and liabilities associated with such use, and will hold Diodes and all companies whose products are represented herein or on Diodes' websites, harmless against all damages and liabilities.
4. Products described herein may be covered by one or more United States, international or foreign patents and pending patent applications. Product names and markings noted herein may also be covered by one or more United States, international or foreign trademarks and trademark applications. Diodes does not convey any license under any of its intellectual property rights or the rights of any third parties (including third parties whose products and services may be described in this document or on Diodes' website) under this document.
5. Diodes' products are provided subject to Diodes' Standard Terms and Conditions of Sale (<https://www.diodes.com/about/company/terms-and-conditions/terms-and-conditions-of-sales/>) or other applicable terms. This document does not alter or expand the applicable warranties provided by Diodes. Diodes does not warrant or accept any liability whatsoever in respect of any products purchased through unauthorized sales channel.
6. Diodes' products and technology may not be used for or incorporated into any products or systems whose manufacture, use or sale is prohibited under any applicable laws and regulations. Should customers or users use Diodes' products in contravention of any applicable laws or regulations, or for any unintended or unauthorized application, customers and users will (a) be solely responsible for any damages, losses or penalties arising in connection therewith or as a result thereof, and (b) indemnify and hold Diodes and its representatives and agents harmless against any and all claims, damages, expenses, and attorney fees arising out of, directly or indirectly, any claim relating to any noncompliance with the applicable laws and regulations, as well as any unintended or unauthorized application.
7. While efforts have been made to ensure the information contained in this document is accurate, complete and current, it may contain technical inaccuracies, omissions and typographical errors. Diodes does not warrant that information contained in this document is error-free and Diodes is under no obligation to update or otherwise correct this information. Notwithstanding the foregoing, Diodes reserves the right to make modifications, enhancements, improvements, corrections or other changes without further notice to this document and any product described herein. This document is written in English but may be translated into multiple languages for reference. Only the English version of this document is the final and determinative format released by Diodes.
8. Any unauthorized copying, modification, distribution, transmission, display or other use of this document (or any portion hereof) is prohibited. Diodes assumes no responsibility for any losses incurred by the customers or users or any third parties arising from any such unauthorized use.
9. This Notice may be periodically updated with the most recent version available at <https://www.diodes.com/about/company/terms-and-conditions/important-notice>

The Diodes logo is a registered trademark of Diodes Incorporated in the United States and other countries.
All other trademarks are the property of their respective owners.
© 2024 Diodes Incorporated. All Rights Reserved.

www.diodes.com

Looking for pricing, stock, or lifecycle information?

Click below to explore more details on WIN SOURCE:

 [View AL8866QSP-13](#) on WIN SOURCE

 [Diodes Incorporated](#) Information

Optimize Your Supply Chain with WIN SOURCE Solutions

-  Global Sourcing Solution
-  Obsolete Management
-  Cost Control Management
-  Shortage Management
-  Alternative Solution
-  Excess Inventory Management