



**THE DATASHEET OF  
BUK4D16-20X**



# AWR6843AOP Single-Chip 60 to 64GHz mmWave Sensor Antennas-On-Package (AOP)

## 1 Features

- FMCW transceiver
  - Integrated 4 receivers and 3 transmitters Antennas-On-Package (AOP)
  - Integrated PLL, transmitter, receiver, Baseband, and ADC
  - 60 to 64GHz coverage with 4GHz continuous bandwidth
  - Supports 6-bit phase shifter
  - Ultra-accurate chirp engine based on fractional-N PLL
- Built-in calibration and self-test
  - Arm® Cortex®-R4F-based radio control system
  - Built-in firmware (ROM)
  - Self-calibrating system across process and temperature
  - Embedded self-monitoring with no host processor involvement on Functional Safety-Compliant devices
- C674x DSP for advanced signal processing (AWR6843 only)
- Hardware accelerator for FFT, filtering, and CFAR processing
- Memory compression
- Arm® Cortex®-R4F microcontroller for object detection, and interface control
  - Supports autonomous mode (loading user application from QSPI flash memory)
- Internal memory with ECC
  - AWR6843: 1.75MB, divided into MSS program RAM (512KB), MSS data RAM (192KB), DSP L1RAM (64KB) and L2 RAM (256KB), and L3 radar data cube RAM (768KB)
  - AWR6443: 1.4MB, divided into MSS program RAM (512KB), MSS data RAM (192KB), and L3 radar data cube RAM (768KB)
  - Technical reference manual includes allowed size modifications
- Other interfaces available to user application
  - Up to 6 ADC channels (low sample rate monitoring)
  - Up to 2 SPI ports
  - Up to 2 UARTs
  - 2 CAN-FD interfaces
  - I2C
  - GPIOs
  - 2 lane LVDS interface for raw ADC data and debug instrumentation
- Device Security (*on select part variants*)
  - Secure authenticated and encrypted boot support
  - Customer programmable root keys, symmetric keys (256 bit), Asymmetric keys (up to RSA-2K) with Key revocation capability
  - Crypto software accelerators - PKA , AES (up to 256 bit), SHA (up to 256 bit), TRNG/DRGB
- **Functional Safety-Compliant**
  - Developed for functional safety applications
  - Documentation available to aid ISO 26262 functional safety system design up to ASIL-D
  - Hardware integrity up to ASIL-B
  - Safety-related certification
    - ISO 26262 certified up to ASIL B by TUV SUD
- AEC-Q100 qualified
- Power management
  - Built-in LDO network for enhanced PSRR
  - I/Os support dual voltage 3.3V/1.8V
- Clock source
  - 40.0MHz crystal with internal oscillator
  - Supports external oscillator at 40MHz
  - Supports externally driven clock (square/sine) at 40MHz
- Easy hardware design
  - 0.8mm pitch, 180-pin 15mm × 15mm flip chip BGA package (ALP) for easy assembly and low-cost PCB design
  - Small solution size
- Operating conditions:
  - Junction temperature range of –40°C to 125°C



## 2 Applications

- Interior Cabin sensing
- Child presence detection
- Occupancy detection
- Seat belt reminder
- Driver vital sign monitoring
- Kick sensor/access sensor
- Intruder detection
- Gesture based HMI
- Gesture recognition

## 3 Description

The AWR6843AOP is an Antenna-on-Package (AOP) device that is an evolution within the single-chip radar device family from Texas Instruments (TI). This device enables unprecedented levels of integration in an extremely small form factor and is an ideal solution for low power, self-monitored, ultra-accurate radar systems in the Automotive space. Multiple automotive qualified variants are currently available including Functional Safety-Compliant devices (ASIL-B) and non-functional safety devices.

It integrates a DSP subsystem, which contains TI's high-performance C674x DSP for the Radar Signal processing. The device includes a BIST processor subsystem, which is responsible for radio configuration, control, and calibration. Additionally, the device includes a user programmable Arm Cortex-R4F based for automotive interfacing. The Hardware Accelerator block (HWA) can perform radar processing and can offload the DSP in order to execute higher level algorithms. Simple programming model changes can enable a wide variety of sensor applications with the possibility of dynamic reconfiguration for implementing a multimode sensor. Additionally, the device is provided as a complete platform solution including reference hardware design, software drivers, sample configurations, API guide, and user documentation.

### Device Information

PART NUMBER	PACKAGE <sup>(1)</sup>	BODY SIZE <sup>(2)</sup>	TRAY / TAPE AND REEL
AWR6843ARBGALPQ1	FCBGA (180)	15mm × 15mm	Tray
AWR6843ARBGALPRQ1	FCBGA (180)	15mm × 15mm	Tape and Reel
AWR6843ARBSALPQ1	FCBGA (180)	15mm × 15mm	Tray
AWR6843ARBSALPRQ1	FCBGA (180)	15mm × 15mm	Tape and Reel

(1) For more information, see [Section 13, Mechanical, Packaging, and Orderable information](#).

(2) The package size (length × width) is a nominal value and includes pins, where applicable.

## 4 Functional Block Diagram

Figure 4-1 shows the functional block diagram of the device.

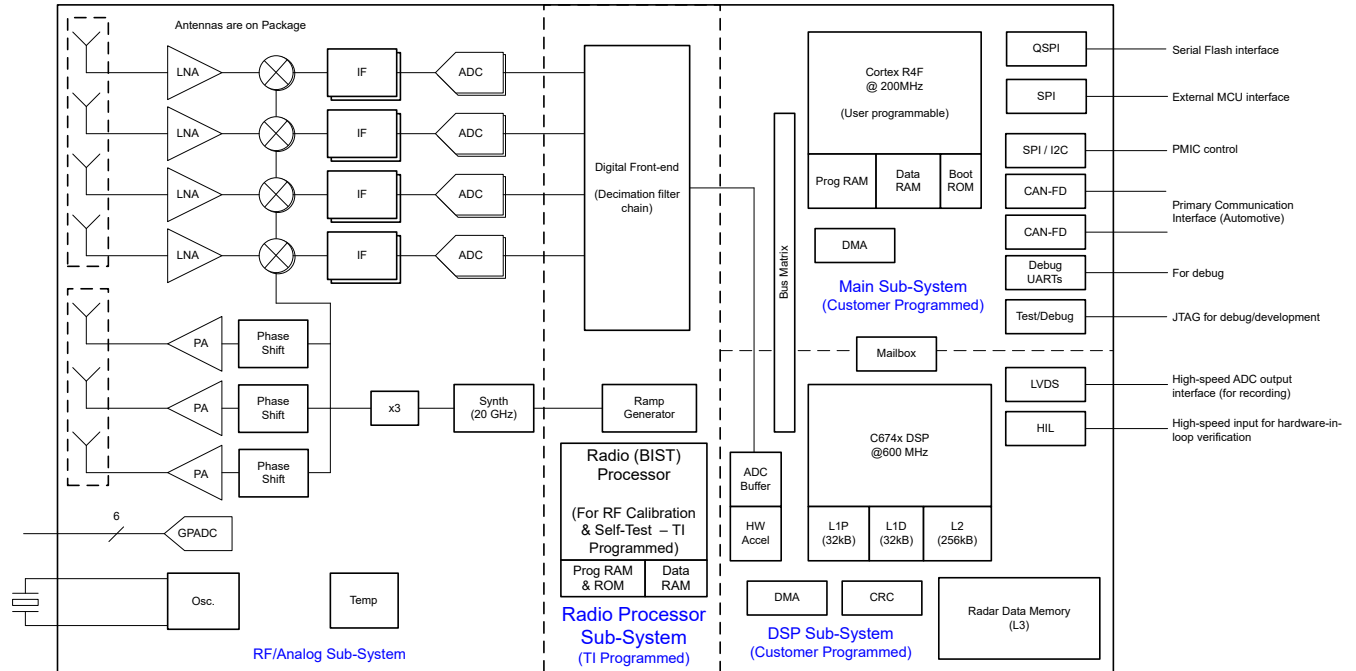

**Figure 4-1. Functional Block Diagram**

## Table of Contents

<b>1 Features</b> .....	<b>1</b>	<b>8 Detailed Description</b> .....	<b>64</b>
<b>2 Applications</b> .....	<b>2</b>	8.1 Overview.....	64
<b>3 Description</b> .....	<b>2</b>	8.2 Functional Block Diagram.....	64
<b>4 Functional Block Diagram</b> .....	<b>3</b>	8.3 Subsystems.....	65
<b>5 Device Comparison</b> .....	<b>5</b>	8.4 Other Subsystems.....	69
5.1 Related Products.....	7	8.5 Boot Modes.....	70
<b>6 Terminal Configuration and Functions</b> .....	<b>8</b>	<b>9 Monitoring and Diagnostics</b> .....	<b>74</b>
6.1 Pin Diagram.....	8	9.1 Monitoring and Diagnostic Mechanisms.....	74
6.2 Signal Descriptions.....	9	<b>10 Applications, Implementation, and Layout</b> .....	<b>79</b>
6.3 Pin Attributes.....	14	10.1 Application Information.....	79
<b>7 Specifications</b> .....	<b>28</b>	10.2 Reference Schematic.....	79
7.1 Absolute Maximum Ratings.....	28	<b>11 Device and Documentation Support</b> .....	<b>80</b>
7.2 ESD Ratings.....	28	11.1 Device Nomenclature.....	80
7.3 Power-On Hours (POH).....	29	11.2 Tools and Software.....	82
7.4 Recommended Operating Conditions.....	30	11.3 Documentation Support.....	82
7.5 VPP Specifications for One-Time Programmable (OTP) eFuses.....	31	11.4 Support Resources.....	82
7.6 Power Supply Specifications.....	31	11.5 Trademarks.....	82
7.7 Power Consumption Summary.....	32	11.6 Electrostatic Discharge Caution.....	82
7.8 Power Save Mode.....	33	11.7 Glossary.....	82
7.9 RF Specification.....	34	<b>12 Revision History</b> .....	<b>83</b>
7.10 CPU Specifications.....	34	<b>13 Mechanical, Packaging, and Orderable Information</b> .....	<b>85</b>
7.11 Thermal Resistance Characteristics for FCBGA Package [ALP0180A].....	35	13.1 Packaging Information.....	85
7.12 Timing and Switching Characteristics.....	36	13.2 Tray Information for ALP, 15 × 15 mm .....	85

## 5 Device Comparison

**Table 5-1. Device Features Comparison**

FUNCTION	AWR6843AOP <sup>(1)</sup>	AWR1843AOP	AWR6843	AWR6443	AWR1843	AWR1642	AWR1443	AWRL6432	AWRL1432
Antenna on Package (AOP)	Yes	Yes	—	—	—	—	—	—	—
Number of receivers	4	4	4	4	4	4	4	3	3
Number of transmitters	3 <sup>(2)</sup>	3 <sup>(2)</sup>	3 <sup>(2)</sup>	3 <sup>(2)</sup>	3 <sup>(2)</sup>	2	3	2	2
RF frequency range	60 to 64 GHz	76 to 81 GHz	60 to 64 GHz	60 to 64 GHz	76 to 81 GHz	76 to 81 GHz	76 to 81 GHz	57 to 64GHz	57 to 64GHz
On-chip memory	1.75MB	2MB	1.75MB	1.4MB	2MB	1.5MB	576KB	1MB	1MB
Max I/F (Intermediate Frequency) (MHz)	10	10	10	10	10	5	5	5	5
Max real sampling rate (Msps)	25	25	25	25	25	12.5	12.5	12.5	12.5
Max complex sampling rate (Msps)	12.5	12.5	12.5	12.5	12.5	6.25	6.25	—	—
Device Security <sup>(3)</sup>	Yes	Yes	Yes	—	Yes	Yes	—	—	—
<b>Processors</b>									
MCU	Yes	Yes	Yes	Yes	Yes	Yes	Yes	Yes	Yes
DSP (C674x)	Yes	Yes	Yes	—	Yes	Yes	—	—	—
<b>Peripherals</b>									
Serial Peripheral Interface (SPI) ports	2	2	2	2	2	2	1	2	2
Quad Serial Peripheral Interface (QSPI)	Yes	Yes	Yes	Yes	Yes	Yes	Yes	Yes	Yes
Inter-Integrated Circuit (I <sup>2</sup> C) interface	1	1	1	1	1	1	1	1	1
Controller Area Network (DCAN) interface	—	1	—	—	1	1	1	—	—
Controller Area Network (CAN-FD) interface	2	1	2	2	1	—	—	1	1
Trace	Yes	Yes	Yes	Yes	Yes	Yes	—	—	—
PWM	Yes	Yes	Yes	Yes	Yes	Yes	—	Yes	Yes
Hardware In Loop (HIL/DMM)	Yes	Yes	Yes	Yes	Yes	Yes	—	—	—
GPADC	Yes	Yes	Yes	Yes	Yes	Yes	Yes	Yes	Yes
LVDS/Debug <sup>(4)</sup>	Yes	Yes	Yes	Yes	Yes	Yes	Yes	—	—
CSI2	—	—	—	—	—	—	—	—	—
Hardware accelerator	Yes	Yes	Yes	Yes	Yes	—	Yes	Yes	Yes
1-V bypass mode	Yes	Yes	Yes	Yes	Yes	Yes	Yes	N/A	N/A
JTAG	Yes	Yes	Yes	Yes	Yes	Yes	Yes	Yes	Yes
Product status	Product Preview (PP), Advance Information (AI), or Production Data (PD)	PD <sup>(5)</sup>	PD <sup>(5)</sup>	PD <sup>(5)</sup>	PD <sup>(5)</sup>	PD <sup>(5)</sup>	PD <sup>(5)</sup>	PD <sup>(5)</sup>	PD <sup>(5)</sup>

(1) Developed for Functional Safety applications, the device supports hardware integrity upto ASIL-B. Refer to the related documentation for more details.

- (2) 3 Tx Simultaneous operation is supported only with 1-V LDO bypass and PA LDO disable mode. In this mode, the 1-V supply needs to be fed on the VOUT PA pin.
- (3) Device security features including Secure Boot and Customer Programmable Keys are available in select devices for only select part variants as indicated by the Device Type identifier in Section 3, Device Information table.
- (4) The LVDS interface is not a production interface and is only used for debug.
- (5) PRODUCTION DATA information is current as of publication date. Products conform to specifications per the terms of the Texas Instruments standard warranty. ADVANCE INFORMATION for pre-production products; subject to change without notice.

## 5.1 Related Products

For information about other devices in this family of products or related products see the links that follow.

- mmWave sensors** TI's mmWave sensors rapidly and accurately sense range, angle and velocity with less power using the smallest footprint mmWave sensor portfolio for automotive applications.
- Automotive mmWave sensors** TI's automotive mmWave sensor portfolio offers high-performance radar front end to ultra-high resolution, small and low-power single-chip radar solutions. TI's scalable sensor portfolio enables design and development of ADAS system solution for every performance, application and sensor configuration ranging from comfort functions to safety functions in all vehicles.
- Companion products for AWR6843** Review products that are frequently purchased or used in conjunction with this product.
- Reference designs for AWR6843** TI Designs Reference Design Library is a robust reference design library spanning analog, embedded processor and connectivity. Created by TI experts to help you jump-start your system design, all TI Designs include schematic or block diagrams, BOMs, and design files to speed your time to market. Search and download designs at [ti.com/tidesigns](https://ti.com/tidesigns).
- Vehicle occupant detection reference design** This reference design demonstrates the use of the AWR6843 60GHz single-chip mmWave sensor with integrated DSP, as a Vehicle Occupant Detection (VOD) and Child Presence Detection (CPD) Sensor enabling the detection of life forms in a vehicle. This design provides a reference software processing chain which runs on the C674x DSP, enabling the generation of a heat map to detect occupants in a Field of View (FOV) of  $\pm 60$  degrees.

## 6 Terminal Configuration and Functions

### 6.1 Pin Diagram

Figure 6-1 shows the pin locations for the 180-pin 15 × 15 mm FCBGA package

	18	17	16	15	14	13	12	11	10	9	8	7	6	5	4	3	2	1	
V	VSSA	VSSA	RS232_RX	VDDIN	VNWA	MCU_CLKOUT	VIN_SRAM	VIQIN_18	PMIC_CLKOUT	VIQIN	VDDIN	VNWA	VIN_SRAM	DP2	VDDIN	DP4	VPP	VSS	V
U	VSSA	VSSA	RS232_TX	NERROR_OUT	NERROR_IN	WARM_RESET	SYNC_IN	NRESET	TDO	TDI	TMS	DP0	DP1	DP3	DMM_SYNC	DMM_CLK	VIQIN_18_DIFF	VSS	U
T	GPADC_4	VSSA	VSS	VSS	VSS	VSS	VSS	VSS	VSS	VSS	VSS	VSS	VSS	VSS	VSS	TCK	LVDS_F_RCLKM	LVDS_F_RCLKP	T
R	GPADC_3	VSSA	VSSA													VSS	LVDS_C_LKM	LVDS_C_LKP	R
P	GPADC_1	GPADC_2	VSSA													VSS	LVDS_T_XP(1)	LVDS_T_XM(1)	P
N	VSSA	VSSA	VSSA													VSS	LVDS_T_XP(0)	LVDS_T_XM(0)	N
M	VIN_18B_B	VIN_18B_B	VIN_18B_B													SYNC_OUT	GPIO_0	DP5	M
L	VSSA	VSSA	VSSA													GPIO_1	DP6	DP7	L
K	VSSA	VSSA	VSSA													GPIO_2	QSPI(3)	VIQIN_18	K
J	VIN_13R_F1	VIN_13R_F1	VIN_13R_F1													QSPI(2)	QSPIC_S_N	VDDIN	J
H	VIN_13R_F2	VIN_13R_F2	VIN_13R_F2													QSPI(0)	QSPICLK	VIQIN	H
G	VOUT_PA	VOUT_PA	VOUT_PA													SPIB_MISO	QSPI(1)	SPIB_MOSI	G
F	VSSA	VSSA	VSSA													VSS	SPIA_MOSI	VIQIN_18	F
E	VSSA	VSSA	VSSA													VSS	SPIB_CLK	VDDIN	E
D	VSSA	VSSA	VSSA													SPIB_CS_N	SPIA_CLK	SPIA_MISO	D
C	VIN_18C_LK	VSSA	VSSA	VIN_18C_LK	VSSA	VSSA	VSSA	VIN_18V_CO	GPADC_6	GPADC_5	VSSA	VSSA	VSSA	DP14	DP10	DP8	SPIA_CS_N	VNWA	C
B	VSSA	VSSA	VSSA	VSSA	VSSA	VSSA	VSSA	VSSA	VSSA	VSSA	VSSA	CLKM	VSSA	DP15	DP12	DP9	SPLHQ_ST_INTR	VIQIN_18	B
A	VSSA	VSSA	VBGAP	VSSA	OSC_CLKOUT	VSSA	VIN_18V_CO	VSSA	VOUT_1_4APLL	VOUT_1_4SYNTH	VSSA	CLKP	VSSA	VIN_SRAM	DP13	DP11	VSS	VSS	A

Figure 6-1. Pin Diagram (Top View)

## 6.2 Signal Descriptions

### Note

All IO pins of the device (except NERROR\_IN, NERROR\_OUT, and WARM\_RESET) are non-failsafe; hence, care needs to be taken that they are not driven externally without the VIO supply being present to the device.

### Note

The GPIO state during the power supply ramp is not ensured. In case the GPIO is used in the application where the state of the GPIO is critical, even when NRESET is low, a tri-state buffer should be used to isolate the GPIO output from the radar device and a pull resistor used to define the required state in the application. The NRESET signal to the radar device could be used to control the output enable (OE) of the tri-state buffer.

### 6.2.1 Pin Functions - Digital and Analog [ALP Package]

NAME	I/O	DESCRIPTION	NO.
<b>DIGITAL</b>			
BSS_UART_TX	O	Debug UART Transmit [Radar Block]	D3, E2, K3, L2, U8, U10, U16, V16
CAN1_FD_RX	I	CAN1 FD (MCAN) Receive Signal	A4, B3, E2, F2, K2, U8, V16
CAN1_FD_TX	O	CAN1 FD (MCAN) Transmit Signal	C2, C3, D1, D3, J3, T3, U16
CAN2_FD_RX	I	CAN2 FD (MCAN) Receive Signal	D2
CAN2_FD_TX	O	CAN2 FD (MCAN) Transmit Signal	B4
DMM0	I	Debug Interface (Hardware In Loop) - Data Line	U7
DMM1	I	Debug Interface (Hardware In Loop) - Data Line	U6
DMM2	I	Debug Interface (Hardware In Loop) - Data Line	V5
DMM3	I	Debug Interface (Hardware In Loop) - Data Line	U5
DMM4	I	Debug Interface (Hardware In Loop) - Data Line	V3
DMM5	I	Debug Interface (Hardware In Loop) - Data Line	M1
DMM6	I	Debug Interface (Hardware In Loop) - Data Line	L2
DMM7	I	Debug Interface (Hardware In Loop) - Data Line	L1
DMM8	I	Debug Interface (Hardware In Loop) - Data Line	C3
DMM9	I	Debug Interface (Hardware In Loop) - Data Line	B3
DMM10	I	Debug Interface (Hardware In Loop) - Data Line	C4
DMM11	I	Debug Interface (Hardware In Loop) - Data Line	A3
DMM12	I	Debug Interface (Hardware In Loop) - Data Line	B4
DMM13	I	Debug Interface (Hardware In Loop) - Data Line	A4
DMM14	I	Debug Interface (Hardware In Loop) - Data Line	C5
DMM15	I	Debug Interface (Hardware In Loop) - Data Line	B5
DMM_CLK	I	Debug Interface (Hardware In Loop) - Clock	U3
DMM_MUX_IN	I	Debug Interface (Hardware In Loop) Mux Select between DMM1 and DMM2 (Two Instances)	L3, M3, U12
DMM_SYNC	I	Debug Interface (Hardware In Loop) - Sync	U4
DSS_UART_TX	O	Debug UART Transmit [DSP]	D2, F2, G3, H2, L1
EPWM1A	O	PWM Module 1 - Output A	B4, U16, V13
EPWM1B	O	PWM Module 1 - Output B	A4, M2, U16, V10

NAME	I/O	DESCRIPTION	NO.
EPWM1SYNCI	I	PWM Module 1 - Sync Input	C3, L3
EPWM1SYNCO	I	PWM Module 1 - Sync Output	B3
EPWM2A	O	PWM Module 2- Output A	C5, M2, U16, V10, V16
EPWM2B	O	PWM Module 2 - Output B	B5, V16
EPWM2SYNCO	O	PWM Module 2 - Sync Output	V3
EPWM3A	O	PWM Module 3 - Output A	C4, V16
EPWM3B	O	PWM Module 3 - Output A	A3
EPWM3SYNCO	O	PWM Module 3 - Sync Output	U5
GPIO_0	IO	General-purpose I/O	M2
GPIO_1	IO	General-purpose I/O	L3
GPIO_2	IO	General-purpose I/O	K3
GPIO_3	IO	General-purpose I/O	D2
GPIO_4	IO	General-purpose I/O	D3
GPIO_5	IO	General-purpose I/O	E2
GPIO_6	IO	General-purpose I/O	J2
GPIO_7	IO	General-purpose I/O	H2
GPIO_8	IO	General-purpose I/O	H3
GPIO_9	IO	General-purpose I/O	G2
GPIO_10	IO	General-purpose I/O	J3
GPIO_11	IO	General-purpose I/O	K2
GPIO_12	IO	General-purpose I/O	B2
GPIO_13	IO	General-purpose I/O	M2
GPIO_14	IO	General-purpose I/O	U16
GPIO_15	IO	General-purpose I/O	V16
GPIO_16	IO	General-purpose I/O	L3
GPIO_17	IO	General-purpose I/O	T3
GPIO_18	IO	General-purpose I/O	U8
GPIO_19	IO	General-purpose I/O	F2
GPIO_20	IO	General-purpose I/O	D1
GPIO_21	IO	General-purpose I/O	G1
GPIO_22	IO	General-purpose I/O	G3
GPIO_23	IO	General-purpose I/O	U9
GPIO_24	IO	General-purpose I/O	U10
GPIO_25	IO	General-purpose I/O	V13
GPIO_26	IO	General-purpose I/O	K3
GPIO_27	IO	General-purpose I/O	V10
GPIO_28	IO	General-purpose I/O	U12
GPIO_29	IO	General-purpose I/O	M3
GPIO_30	IO	General-purpose I/O	C2, D2
GPIO_31	IO	General-purpose I/O	U7
GPIO_32	IO	General-purpose I/O	U6
GPIO_33	IO	General-purpose I/O	V5
GPIO_34	IO	General-purpose I/O	U5
GPIO_35	IO	General-purpose I/O	V3
GPIO_36	IO	General-purpose I/O	M1
GPIO_37	IO	General-purpose I/O	L2

NAME	I/O	DESCRIPTION	NO.
GPIO_38	IO	General-purpose I/O	L1
GPIO_39	IO	General-purpose I/O	C3
GPIO_40	IO	General-purpose I/O	B3
GPIO_41	IO	General-purpose I/O	C4
GPIO_42	IO	General-purpose I/O	A3
GPIO_43	IO	General-purpose I/O	B4
GPIO_44	IO	General-purpose I/O	A4
GPIO_45	IO	General-purpose I/O	C5
GPIO_46	IO	General-purpose I/O	B5
GPIO_47	IO	General-purpose I/O	U3
I2C_SCL	IO	I2C Clock	G3, V16
I2C_SDA	IO	I2C Data	G1, U16
LVDS_TXP[0]	O	Differential data Out – Lane 0	N2
LVDS_TXM[0]	O	Differential data Out – Lane 0	N1
LVDS_TXP[1]	O	Differential data Out – Lane 1	P2
LVDS_TXM[1]	O	Differential data Out – Lane 1	P1
LVDS_CLKP	O	Differential clock Out	R1
LVDS_CLKM	O	Differential clock Out	R2
LVDS_FRCLKP	O	Differential Frame Clock	T1
LVDS_FRCLKM	O	Differential Frame Clock	T2
MCU_CLKOUT	O	Programmable clock given out to external MCU or the processor	V13
MSS_UARTA_RX	I	Main Subsystem - UART A Receive	E2, U9, V16
MSS_UARTA_TX	O	Main Subsystem - UART A Transmit	D3, U7, U10, U16
MSS_UARTB_RX	IO	Main Subsystem - UART B Receive	U12, V16
MSS_UARTB_TX	O	Main Subsystem - UART B Transmit	D3, E2, K3, M1, T3, U10, U16
NDMM_EN	I	Debug Interface (Hardware In Loop) Enable - Active Low Signal	U10, U16
NERROR_IN	I	Failsafe input to the device. Nerror output from any other device can be concentrated in the error signaling monitor module inside the device and appropriate action can be taken by Firmware	U14
NERROR_OUT	O	Open drain fail safe output signal. Connected to PMIC/ Processor/MCU to indicate that some severe criticality fault has happened. Recovery would be through reset.	U15
PMIC_CLKOUT	O	Output Clock from AWR6843AOP device for PMIC	K3, M2, V10
QSPI[0]	IO	QSPI Data Line #0 (Used with Serial Data Flash)	H3
QSPI[1]	I	QSPI Data Line #1 (Used with Serial Data Flash)	G2
QSPI[2]	I	QSPI Data Line #2 (Used with Serial Data Flash)	J3
QSPI[3]	I	QSPI Data Line #3 (Used with Serial Data Flash)	K2
QSPI_CLK	O	QSPI Clock (Used with Serial Data Flash)	H2
QSPI_CLK_EXT	I	QSPI Clock (Used with Serial Data Flash)	D3
QSPI_CS_N	O	QSPI Chip Select (Used with Serial Data Flash)	J2
RS232_RX	I	Debug UART (Operates as Bus Master) - Receive Signal	V16
RS232_TX	O	Debug UART (Operates as Bus Master) - Transmit Signal	U16
SOP[0]	I	Sense On Power - Line#0	U10
SOP[1]	I	Sense On Power - Line#1	M3
SOP[2]	I	Sense On Power - Line#2	V10
SPIA_CLK	IO	SPI Channel A - Clock	D2
SPIA_CS_N	IO	SPI Channel A - Chip Select	C2

NAME	I/O	DESCRIPTION	NO.
SPIA_MISO	IO	SPI Channel A - Master In Slave Out	D1
SPIA_MOSI	IO	SPI Channel A - Master Out Slave In	F2
SPIB_CLK	IO	SPI Channel B - Clock	E2, H2
SPIB_CS_N	IO	SPI Channel B Chip Select (Instance ID 0)	D3, J2
SPIB_CS_N_1	IO	SPI Channel B Chip Select (Instance ID 1)	B2, L3, M3
SPIB_CS_N_2	IO	SPI Channel B Chip Select (Instance ID 2)	G2, L3, M3
SPIB_MISO	IO	SPI Channel B - Master In Slave Out	G3, H3
SPIB_MOSI	IO	SPI Channel B - Master Out Slave In	G1, G2
SPI_HOST_INTR	O	Out of Band Interrupt to an external host communicating over SPI	B2
SYNC_IN	I	Low frequency Synchronization signal input	U12
SYNC_OUT	O	Low Frequency Synchronization Signal output	K3, L3, M3, U12
TCK	I	JTAG Test Clock	T3
TDI	I	JTAG Test Data Input	U9
TDO	O	JTAG Test Data Output	U10
TMS	I	JTAG Test Mode Signal	U8
TRACE_CLK	O	Debug Trace Output - Clock	U3
TRACE_CTL	O	Debug Trace Output - Control	U4
TRACE_DATA_0	O	Debug Trace Output - Data Line	U7
TRACE_DATA_1	O	Debug Trace Output - Data Line	U6
TRACE_DATA_2	O	Debug Trace Output - Data Line	V5
TRACE_DATA_3	O	Debug Trace Output - Data Line	U5
TRACE_DATA_4	O	Debug Trace Output - Data Line	V3
TRACE_DATA_5	O	Debug Trace Output - Data Line	M1
TRACE_DATA_6	O	Debug Trace Output - Data Line	L2
TRACE_DATA_7	O	Debug Trace Output - Data Line	L1
TRACE_DATA_8	O	Debug Trace Output - Data Line	C3
TRACE_DATA_9	O	Debug Trace Output - Data Line	B3
TRACE_DATA_10	O	Debug Trace Output - Data Line	C4
TRACE_DATA_11	O	Debug Trace Output - Data Line	A3
TRACE_DATA_12	O	Debug Trace Output - Data Line	B4
TRACE_DATA_13	O	Debug Trace Output - Data Line	A4
TRACE_DATA_14	O	Debug Trace Output - Data Line	C5
TRACE_DATA_15	O	Debug Trace Output - Data Line	B5
FRAME_START	O	Pulse signal indicating the start of each frame	K3, V10, V13
CHIRP_START	O	Pulse signal indicating the start of each chirp	K3, V10, V13
CHIRP_END	O	Pulse signal indicating the end of each chirp	K3, V10, V13
ADC_VALID	O	When high, indicating valid ADC samples	B2, L3, M2
WARM_RESET	IO	Open drain fail safe warm reset signal. Can be driven from PMIC for diagnostic or can be used as status signal that the device is going through reset.	U13
<b>ANALOG</b>			
NRESET	I	Power on reset for chip. Active low	U11
CLKP	I	In XTAL mode: Differential port for reference crystal In External clock mode: Single ended input reference clock port	A7
CLKM	I	In XTAL mode: Differential port for reference crystal In External clock mode: Connect this port to ground	B7
OSC_CLKOUT	O	Reference clock output from clocking sub system after cleanup PLL (1.4-V output voltage swing).	A14, K3

NAME	I/O	DESCRIPTION	NO.
VBGAP	O	Device's Band Gap Reference Output	A16
VDDIN	Power	1.2V digital power supply	E1, J1, V4, V8, V15
VIN_SRAM	Power	1.2V power rail for internal SRAM	A5, V6, V12
VNWA	Power	1.2V power rail for SRAM array back bias	C1, V7, V14
VIOIN	Power	I/O Supply (3.3V or 1.8V): All CMOS I/Os would operate on this supply	H1, V9
VIOIN_18	Power	1.8V supply for CMOS IO	B1, F1, K1, V11
VIN_18CLK	Power	1.8V supply for clock module	C15, C18
VIOIN_18DIFF	Power	1.8V supply for LVDS port	U2
VPP	Power	Voltage supply for fuse chain	V2
VIN_13RF1	Power	1.3V Analog and RF supply, VIN_13RF1 and VIN_13RF2 could be shorted on the board	J16, J17, J18
VIN_13RF2	Power	1.3V Analog and RF supply	H16, H17, H18
VIN_18BB	Power	1.8V Analog base band power supply	M16, M17, M18
VIN_18VCO	Power	1.8V RF VCO supply	A12, C11
VSS	Ground	Digital ground	A1, A2, E3, F3, N3, P3, R3, T4, T5, T6, T7, T8, T9, T10, T11, T12, T13, T14, T15, T16, U1, V1
VSSA	Ground	Analog ground	A6, A8, A11, A13, A15, A17, A18, B6, B8, B9, B10, B11, B12, B13, B14, B15, B16, B17, B18, C6, C7, C8, C12, C13, C14, C16, C17, D16, D17, D18, E16, E17, E18, F16, F17, F18, K16, K17, K18, L16, L17, L18, N16, N17, N18, P16, R16, R17, T17, U17, U18, V17, V18
VOUT_14APLL	O	Internal LDO output	A10
VOUT_14SYNTH	O	Internal LDO output	A9
VOUT_PA	IO	Internal LDO output	G16, G17, G18
Analog Test1 / GPADC1	IO	Analog IO dedicated for ADC service	P18
Analog Test2 / GPADC2	IO	Analog IO dedicated for ADC service	P17
Analog Test3 / GPADC3	IO	Analog IO dedicated for ADC service	R18
Analog Test4 / GPADC4	IO	Analog IO dedicated for ADC service	T18
ANAMUX / GPADC5	IO	Analog IO dedicated for ADC service	C9
VSENSE / GPADC6	IO	Analog IO dedicated for ADC service	C10

## 6.3 Pin Attributes

**Table 6-1. Pin Attributes (ALP180A Package)**

BALL NUMBER [1]	BALL NAME [2]	SIGNAL NAME [3]	PINCNTL ADDRESS [4]	MODE [5] [9]	TYPE [6]	BALL RESET STATE [7]	PULL UP/DOWN TYPE [8]					
M2	GPIO_0	GPIO_13	0xFFFFEA04	0	IO	Output Disabled	Pull Down					
		GPIO_0		1	IO							
		PMIC_CLKOUT		2	O							
		EPWM1B		10	O							
		ePWM2A		11	O							
L3	GPIO_1	GPIO_16	0xFFFFEA08	0	IO	Output Disabled	Pull Down					
		GPIO_1		1	IO							
		SYNC_OUT		2	O							
		DMM_MUX_IN		12	I							
		SPIB_CS_N_1		13	IO							
		SPIB_CS_N_2		14	IO							
		EPWM1SYNCl		15	I							
K3	GPIO_2	GPIO_26	0xFFFFEA64	0	IO	Output Disabled	Pull Down					
		GPIO_2		1	IO							
		OSC_CLKOUT		2	O							
		MSS_UARTB_TX		7	O							
		BSS_UART_TX		8	O							
		SYNC_OUT		9	O							
		PMIC_CLKOUT		10	O							
		CHIRP_START		11	O							
		CHIRP_END		12	O							
		FRAME_START		13	O							
		U7		GPIO_31 (DP0)	TRACE_DATA_0			0xFFFFEA7C	0	O	Output Disabled	Pull Down
					GPIO_31				1	IO		
					DMM0				2	I		
MSS_UARTA_TX	4		IO									
U6	GPIO_32 (DP1)	TRACE_DATA_1	0xFFFFEA80	0	O	Output Disabled	Pull Down					
		GPIO_32		1	IO							
		DMM1		2	I							
V5	GPIO_33 (DP2)	TRACE_DATA_2	0xFFFFEA84	0	O	Output Disabled	Pull Down					
		GPIO_33		1	IO							
		DMM2		2	I							
U5	GPIO_34 (DP3)	TRACE_DATA_3	0xFFFFEA88	0	O	Output Disabled	Pull Down					
		GPIO_34		1	IO							
		DMM3		2	I							
		EPWM3SYNCO		4	O							

**Table 6-1. Pin Attributes (ALP180A Package) (continued)**

BALL NUMBER [1]	BALL NAME [2]	SIGNAL NAME [3]	PINCNTL ADDRESS [4]	MODE [5] [9]	TYPE [6]	BALL RESET STATE [7]	PULL UP/DOWN TYPE [8]
V3	GPIO_35 (DP4)	TRACE_DATA_4	0xFFFFEA8C	0	O	Output Disabled	Pull Down
		GPIO_35		1	IO		
		DMM4		2	I		
		EPWM2SYNCO		4	O		
M1	GPIO_36 (DP5)	TRACE_DATA_5	0xFFFFEA90	0	O	Output Disabled	Pull Down
		GPIO_36		1	IO		
		DMM5		2	I		
		MSS_UARTB_TX		5	O		
L2	GPIO_37 (DP6)	TRACE_DATA_6	0xFFFFEA94	0	O	Output Disabled	Pull Down
		GPIO_37		1	IO		
		DMM6		2	I		
		BSS_UART_TX		5	O		
L1	GPIO_38 (DP7)	TRACE_DATA_7	0xFFFFEA98	0	O	Output Disabled	Pull Down
		GPIO_38		1	IO		
		DMM7		2	I		
		DSS_UART_TX		5	O		
C3	GPIO_39 (DP8)	TRACE_DATA_8	0xFFFFEA9C	0	O	Output Disabled	Pull Down
		GPIO_39		1	IO		
		DMM8		2	I		
		CAN1_FD_TX		4	O		
		EPWM1SYNCI		5	I		
B3	GPIO_40 (DP9)	TRACE_DATA_9	0xFFFFEAA0	0	O	Output Disabled	Pull Down
		GPIO_40		1	IO		
		DMM9		2	I		
		CAN1_FD_RX		4	I		
		EPWM1SYNCO		5	O		
C4	GPIO_41 (DP10)	TRACE_DATA_10	0xFFFFEAA4	0	O	Output Disabled	Pull Down
		GPIO_41		1	IO		
		DMM10		2	I		
		EPWM3A		4	O		
A3	GPIO_42 (DP11)	TRACE_DATA_11	0xFFFFEAA8	0	O	Output Disabled	Pull Down
		GPIO_42		1	IO		
		DMM11		2	I		
		EPWM3B		4	O		
B4	GPIO_43 (DP12)	TRACE_DATA_12	0xFFFFEAA8	0	O	Output Disabled	Pull Down
		GPIO_43		1	IO		
		DMM12		2	I		
		EPWM1A		4	O		
		CAN2_FD_TX		5	O		

**Table 6-1. Pin Attributes (ALP180A Package) (continued)**

BALL NUMBER [1]	BALL NAME [2]	SIGNAL NAME [3]	PINCNTL ADDRESS [4]	MODE [5] [9]	TYPE [6]	BALL RESET STATE [7]	PULL UP/DOWN TYPE [8]
A4	GPIO_44 (DP13)	TRACE_DATA_13	0xFFFFEAB0	0	O	Output Disabled	Pull Down
		GPIO_44		1	IO		
		DMM13		2	I		
		EPWM1B		4	O		
		CAN1_FD_RX		5	I		
C5	GPIO_45 (DP14)	TRACE_DATA_14	0xFFFFEAB4	0	O	Output Disabled	Pull Down
		GPIO_45		1	IO		
		DMM14		2	I		
		EPWM2A		4	O		
B5	GPIO_46 (DP15)	TRACE_DATA_15	0xFFFFEAB8	0	O	Output Disabled	Pull Down
		GPIO_46		1	IO		
		DMM15		2	I		
		EPWM2B		4	O		
U3	GPIO_47 (DMM_CLK)	TRACE_CLK	0xFFFFEABC	0	O	Output Disabled	Pull Down
		GPIO_47		1	IO		
		DMM_CLK		2	I		
U4	DMM_SYNC	TRACE_CTL	0xFFFFEAC0	0	O	Output Disabled	Pull Down
		DMM_SYNC		2	I		
V13	MCU_CLKOUT	GPIO_25	0xFFFFEA60	0	IO	Output Disabled	Pull Down
		MCU_CLKOUT		1	O		
		CHIRP_START		2	O		
		CHIRP_END		6	O		
		FRAME_START		7	O		
		EPWM1A		12	O		
U14	NERROR_IN	NERROR_IN	0xFFFFEA44	0	I	Input	
U15	NERROR_OUT	NERROR_OUT	0xFFFFEA4C	0	O	Hi-Z (Open Drain)	
V10	PMIC_CLKOUT	SOP[2]	0xFFFFEA68	During Power Up	I	Output Disabled	Pull Down
		GPIO_27		0	IO		
		PMIC_CLKOUT		1	O		
		CHIRP_START		6	O		
		CHIRP_END		7	O		
		FRAME_START		8	O		
		EPWM1B		11	O		
		EPWM2A		12	O		
H3	QSPI[0]	GPIO_8	0xFFFFEA2C	0	IO	Output Disabled	Pull Down
		QSPI[0]		1	IO		
		SPIB_MISO		2	IO		

**Table 6-1. Pin Attributes (ALP180A Package) (continued)**

BALL NUMBER [1]	BALL NAME [2]	SIGNAL NAME [3]	PINCNTL ADDRESS [4]	MODE [5] [9]	TYPE [6]	BALL RESET STATE [7]	PULL UP/DOWN TYPE [8]					
G2	QSPI[1]	GPIO_9	0xFFFFEA30	0	IO	Output Disabled	Pull Down					
		QSPI[1]		1	I							
		SPIB_MOSI		2	IO							
		SPIB_CS_N_2		8	IO							
J3	QSPI[2]	GPIO_10	0xFFFFEA34	0	IO	Output Disabled	Pull Down					
		QSPI[2]		1	I							
		CAN1_FD_TX		8	O							
K2	QSPI[3]	GPIO_11	0xFFFFEA38	0	IO	Output Disabled	Pull Down					
		QSPI[3]		1	I							
		CAN1_FD_RX		8	I							
H2	QSPI_CLK	GPIO_7	0xFFFFEA3C	0	IO	Output Disabled	Pull Down					
		QSPI_CLK		1	O							
		SPIB_CLK		2	IO							
		DSS_UART_TX		6	O							
J2	QSPI_CS_N	GPIO_6	0xFFFFEA40	0	IO	Output Disabled	Pull Up					
		QSPI_CS_N		1	O							
		SPIB_CS_N		2	IO							
V16	RS232_RX	GPIO_15	0xFFFFEA74	0	IO	Input Enabled	Pull Up					
		RS232_RX		1	I							
		MSS_UARTA_RX		2	I							
		BSS_UART_TX		6	IO							
		MSS_UARTB_RX		7	IO							
		CAN1_FD_RX		8	I							
		I2C_SCL		9	IO							
		EPWM2A		10	O							
		EPWM2B		11	O							
		EPWM3A		12	O							
		U16		RS232_TX	GPIO_14			0xFFFFEA78	0	IO	Output Enabled	
					RS232_TX				1	O		
MSS_UARTA_TX	5		IO									
MSS_UARTB_TX	6		IO									
BSS_UART_TX	7		IO									
CAN1_FD_TX	10		O									
I2C_SDA	11		IO									
EPWM1A	12		O									
EPWM1B	13		O									
NDMM_EN	14		I									
EPWM2A	15		O									

**Table 6-1. Pin Attributes (ALP180A Package) (continued)**

BALL NUMBER [1]	BALL NAME [2]	SIGNAL NAME [3]	PINCNTL ADDRESS [4]	MODE [5] [9]	TYPE [6]	BALL RESET STATE [7]	PULL UP/DOWN TYPE [8]
D2	SPIA_CLK	GPIO_3	0xFFFFEA14	0	IO	Output Disabled	Pull Up
		SPIA_CLK		1	IO		
		CAN2_FD_RX		6	I		
		DSS_UART_TX		7	O		
C2	SPIA_CS_N	GPIO_30	0xFFFFEA18	0	IO	Output Disabled	Pull Up
		SPIA_CS_N		1	IO		
		CAN1_FD_TX		6	O		
D1	SPIA_MISO	GPIO_20	0xFFFFEA10	0	IO	Output Disabled	Pull Up
		SPIA_MISO		1	IO		
		CAN1_FD_TX		2	O		
F2	SPIA_MOSI	GPIO_19	0xFFFFEA0C	0	IO	Output Disabled	Pull Up
		SPIA_MOSI		1	IO		
		CAN1_FD_RX		2	I		
		DSS_UART_TX		8	O		
E2	SPIB_CLK	GPIO_5	0xFFFFEA24	0	IO	Output Disabled	Pull Up
		SPIB_CLK		1	IO		
		MSS_UARTA_RX		2	I		
		MSS_UARTB_TX		6	O		
		BSS_UART_TX		7	O		
		CAN1_FD_RX		8	I		
D3	SPIB_CS_N	GPIO_4	0xFFFFEA28	0	IO	Output Disabled	Pull Up
		SPIB_CS_N		1	IO		
		MSS_UARTA_TX		2	O		
		MSS_UARTB_TX		6	O		
		BSS_UART_TX		7	IO		
		QSPI_CLK_EXT		8	I		
		CAN1_FD_TX		9	O		
		G3		SPIB_MISO	GPIO_22		
SPIB_MISO	1		IO				
I2C_SCL	2		IO				
DSS_UART_TX	6		O				
G1	SPIB_MOSI	GPIO_21	0xFFFFEA1C	0	IO	Output Disabled	Pull Up
		SPIB_MOSI		1	IO		
		I2C_SDA		2	IO		
B2	SPI_HOST_INTR	GPIO_12	0xFFFFEA00	0	IO	Output Disabled	Pull Down
		SPI_HOST_INTR		1	O		
		SPIB_CS_N_1		6	IO		

**Table 6-1. Pin Attributes (ALP180A Package) (continued)**

BALL NUMBER [1]	BALL NAME [2]	SIGNAL NAME [3]	PINCNTL ADDRESS [4]	MODE [5] [9]	TYPE [6]	BALL RESET STATE [7]	PULL UP/DOWN TYPE [8]
U12	SYNC_IN	GPIO_28	0xFFFFEA6C	0	IO	Output Disabled	Pull Down
		SYNC_IN		1	I		
		MSS_UARTB_RX		6	IO		
		DMM_MUX_IN		7	I		
		SYNC_OUT		9	O		
M3	SYNC_OUT	SOP[1]	0xFFFFEA70	During Power Up	I	Output Disabled	Pull Down
		GPIO_29		0	IO		
		SYNC_OUT		1	O		
		DMM_MUX_IN		9	I		
		SPIB_CS_N_1		10	IO		
		SPIB_CS_N_2		11	IO		
T3	TCK	GPIO_17	0xFFFFEA50	0	IO	Input Enabled	Pull Down
		TCK		1	I		
		MSS_UARTB_TX		2	O		
		CAN1_FD_TX		8	O		
U9	TDI	GPIO_23	0xFFFFEA58	0	IO	Input Enabled	Pull Up
		TDI		1	I		
		MSS_UARTA_RX		2	I		
U10	TDO	SOP[0]	0xFFFFEA5C	During Power Up	I	Output Enabled	
		GPIO_24		0	IO		
		TDO		1	O		
		MSS_UARTA_TX		2	O		
		MSS_UARTB_TX		6	O		
		BSS_UART_TX		7	O		
		NDMM_EN		9	I		
U8	TMS	GPIO_18	0xFFFFEA54	0	IO	Input Enabled	Pull Down
		TMS		1	I		
		BSS_UART_TX		2	O		
		CAN1_FD_RX		6	I		
U13	WARM_RESET	WARM_RESET	0xFFFFEA48	0	IO	Hi-Z Input (Open Drain)	
R2	LVDS_CLKM	LVDS_CLKM			O		
R1	LVDS_CLKP	LVDS_CLKP			O		
N2	LVDS_TXP[0]	LVDS_TXP[0]			O		
N1	LVDS_TXM[0]	LVDS_TXM[0]			O		
P2	LVDS_TXP[1]	LVDS_TXP[1]			O		
P1	LVDS_TXM[1]	LVDS_TXM[1]			O		
T1	LVDS_FRCLKP	LVDS_FRCLKP			O		
T2	LVDS_FRCLKM	LVDS_FRCLKM			O		

**Table 6-1. Pin Attributes (ALP180A Package) (continued)**

BALL NUMBER [1]	BALL NAME [2]	SIGNAL NAME [3]	PINCNTL ADDRESS [4]	MODE [5] [9]	TYPE [6]	BALL RESET STATE [7]	PULL UP/DOWN TYPE [8]
U11	NRESET	NRESET			I		
A7	CLKP	CLKP			I		
B7	CLKM	CLKM			I		
A14	OSC_CLKOUT	OSC_CLKOUT			O		
A16	VBGAP	VBGAP			O		
E1	VDDIN	VDDIN			PWR		
J1	VDDIN	VDDIN			PWR		
V4	VDDIN	VDDIN			PWR		
V8	VDDIN	VDDIN			PWR		
V15	VDDIN	VDDIN			PWR		
A5	VIN_SRAM	VIN_SRAM			PWR		
V6	VIN_SRAM	VIN_SRAM			PWR		
V12	VIN_SRAM	VIN_SRAM			PWR		
C1	VNWA	VNWA			PWR		
V7	VNWA	VNWA			PWR		
V14	VNWA	VNWA			PWR		
H1	VIOIN	VIOIN			PWR		
V9	VIOIN	VIOIN			PWR		
B1	VIOIN_18	VIOIN_18			PWR		
F1	VIOIN_18	VIOIN_18			PWR		
K1	VIOIN_18	VIOIN_18			PWR		
V11	VIOIN_18	VIOIN_18			PWR		
C15	VIN_18CLK	VIN_18CLK			PWR		
C18	VIN_18CLK	VIN_18CLK			PWR		
U2	VIOIN_18DIFF	VIOIN_18DIFF			PWR		
V2	VPP	VPP			PWR		
J16	VIN_13RF1	VIN_13RF1			PWR		
J17	VIN_13RF1	VIN_13RF1			PWR		
J18	VIN_13RF1	VIN_13RF1			PWR		
H16	VIN_13RF2	VIN_13RF2			PWR		
H17	VIN_13RF2	VIN_13RF2			PWR		
H18	VIN_13RF2	VIN_13RF2			PWR		
M16	VIN_18BB	VIN_18BB			PWR		
M17	VIN_18BB	VIN_18BB			PWR		
M18	VIN_18BB	VIN_18BB			PWR		
A12	VIN_18VCO	VIN_18VCO			PWR		
C11	VIN_18VCO	VIN_18VCO			PWR		
A1	VSS	VSS			GND		
A2	VSS	VSS			GND		

**Table 6-1. Pin Attributes (ALP180A Package) (continued)**

BALL NUMBER [1]	BALL NAME [2]	SIGNAL NAME [3]	PINCNTL ADDRESS [4]	MODE [5] [9]	TYPE [6]	BALL RESET STATE [7]	PULL UP/DOWN TYPE [8]
E3	VSS	VSS			GND		
F3	VSS	VSS			GND		
N3	VSS	VSS			GND		
P3	VSS	VSS			GND		
R3	VSS	VSS			GND		
T4	VSS	VSS			GND		
T5	VSS	VSS			GND		
T6	VSS	VSS			GND		
T7	VSS	VSS			GND		
T8	VSS	VSS			GND		
T9	VSS	VSS			GND		
T10	VSS	VSS			GND		
T11	VSS	VSS			GND		
T12	VSS	VSS			GND		
T13	VSS	VSS			GND		
T14	VSS	VSS			GND		
T15	VSS	VSS			GND		
T16	VSS	VSS			GND		
U1	VSS	VSS			GND		
V1	VSS	VSS			GND		
A6	VSSA	VSSA			GND		
A8	VSSA	VSSA			GND		
A11	VSSA	VSSA			GND		
A13	VSSA	VSSA			GND		
A15	VSSA	VSSA			GND		
A17	VSSA	VSSA			GND		
A18	VSSA	VSSA			GND		
B6	VSSA	VSSA			GND		
B8	VSSA	VSSA			GND		
B9	VSSA	VSSA			GND		
B10	VSSA	VSSA			GND		
B11	VSSA	VSSA			GND		
B12	VSSA	VSSA			GND		
B13	VSSA	VSSA			GND		
B14	VSSA	VSSA			GND		
B15	VSSA	VSSA			GND		
B16	VSSA	VSSA			GND		
B17	VSSA	VSSA			GND		
B18	VSSA	VSSA			GND		

**Table 6-1. Pin Attributes (ALP180A Package) (continued)**

BALL NUMBER [1]	BALL NAME [2]	SIGNAL NAME [3]	PINCNTL ADDRESS [4]	MODE [5] [9]	TYPE [6]	BALL RESET STATE [7]	PULL UP/DOWN TYPE [8]
C6	VSSA	VSSA			GND		
C7	VSSA	VSSA			GND		
C8	VSSA	VSSA			GND		
C12	VSSA	VSSA			GND		
C13	VSSA	VSSA			GND		
C14	VSSA	VSSA			GND		
C16	VSSA	VSSA			GND		
C17	VSSA	VSSA			GND		
D16	VSSA	VSSA			GND		
D17	VSSA	VSSA			GND		
D18	VSSA	VSSA			GND		
E16	VSSA	VSSA			GND		
E17	VSSA	VSSA			GND		
E18	VSSA	VSSA			GND		
F16	VSSA	VSSA			GND		
F17	VSSA	VSSA			GND		
F18	VSSA	VSSA			GND		
K16	VSSA	VSSA			GND		
K17	VSSA	VSSA			GND		
K18	VSSA	VSSA			GND		
L16	VSSA	VSSA			GND		
L17	VSSA	VSSA			GND		
L18	VSSA	VSSA			GND		
N16	VSSA	VSSA			GND		
N17	VSSA	VSSA			GND		
N18	VSSA	VSSA			GND		
P16	VSSA	VSSA			GND		
R16	VSSA	VSSA			GND		
R17	VSSA	VSSA			GND		
T17	VSSA	VSSA			GND		
U17	VSSA	VSSA			GND		
U18	VSSA	VSSA			GND		
V17	VSSA	VSSA			GND		
V18	VSSA	VSSA			GND		
A10	VOUT_14APLL	VOUT_14APLL			O		
A9	VOUT_14SYNTH	VOUT_14SYNTH			O		
G16	VOUT_PA	VOUT_PA			IO		
G17	VOUT_PA	VOUT_PA			IO		
G18	VOUT_PA	VOUT_PA			IO		

**Table 6-1. Pin Attributes (ALP180A Package) (continued)**

BALL NUMBER [1]	BALL NAME [2]	SIGNAL NAME [3]	PINCNTL ADDRESS [4]	MODE [5] [9]	TYPE [6]	BALL RESET STATE [7]	PULL UP/DOWN TYPE [8]
P18	Analog Test1 / GPADC1	Analog Test1 / GPADC1			IO		
P17	Analog Test2 / GPADC2	Analog Test2 / GPADC2			IO		
R18	Analog Test3 / GPADC3	Analog Test3 / GPADC3			IO		
T18	Analog Test4 / GPADC4	Analog Test4 / GPADC4			IO		
C9	ANAMUX / GPADC5	ANAMUX / GPADC5			IO		
C10	VSENSE / GPADC6	VSENSE / GPADC6			IO		

The following list describes the table column headers:

1. **BALL NUMBER:** Ball numbers on the bottom side associated with each signal on the bottom.
2. **BALL NAME:** Mechanical name from package device (name is taken from muxmode 1).
3. **SIGNAL NAME:** Names of signals multiplexed on each ball (also notice that the name of the ball is the signal name in muxmode 1).
4. **PINCNTL ADDRESS:** MSS Address for PinMux Control
5. **MODE:** Multiplexing mode number: value written to PinMux Cntl register to select specific Signal name for this Ball number. Mode column has bit range value.
6. **TYPE:** Signal type and direction:
  - I = Input
  - O = Output
  - IO = Input or Output
7. **BALL RESET STATE:** The state of the terminal after supplies are stable after power-on-reset (NRESET) is asserted
8. **PULL UP/DOWN TYPE:** indicates the presence of an internal pullup or pulldown resistor. Pullup and pulldown resistors can be enabled or disabled via software.
  - Pull Up: Internal pullup
  - Pull Down: Internal pulldown
  - An empty box means No pull.
9. Pin Mux Control Value maps to lower 4 bits of register.

IO MUX registers are available in the MSS memory map and the respective mapping to device pins is as follows:

**Table 6-2. PAD IO Control Registers**

Default Pin/Ball Name	Package Ball /Pin (Address)	Pin Mux Config Register
SPI_HOST_INTR	B2	0xFFFFEA00
GPIO_0	M2	0xFFFFEA04
GPIO_1	L3	0xFFFFEA08
SPIA_MOSI	F2	0xFFFFEA0C
SPIA_MISO	D1	0xFFFFEA10
SPIA_CLK	D2	0xFFFFEA14
SPIA_CS_N	C2	0xFFFFEA18
SPIB_MOSI	G1	0xFFFFEA1C
SPIB_MISO	G3	0xFFFFEA20
SPIB_CLK	E2	0xFFFFEA24
SPIB_CS_N	D3	0xFFFFEA28
QSPI[0]	H3	0xFFFFEA2C
QSPI[1]	G2	0xFFFFEA30
QSPI[2]	J3	0xFFFFEA34
QSPI[3]	K2	0xFFFFEA38
QSPI_CLK	H2	0xFFFFEA3C
QSPI_CS_N	J2	0xFFFFEA40
NERROR_IN	U14	0xFFFFEA44
WARM_RESET	U13	0xFFFFEA48
NERROR_OUT	U15	0xFFFFEA4C
TCK	T3	0xFFFFEA50
TMS	U8	0xFFFFEA54
TDI	U9	0xFFFFEA58
TDO	U10	0xFFFFEA5C
MCU_CLKOUT	V13	0xFFFFEA60
GPIO_2	K3	0xFFFFEA64
PMIC_CLKOUT	V10	0xFFFFEA68
SYNC_IN	U12	0xFFFFEA6C
SYNC_OUT	M3	0xFFFFEA70
RS232_RX	V16	0xFFFFEA74
RS232_TX	U16	0xFFFFEA78

**Table 6-2. PAD IO Control Registers (continued)**

Default Pin/Ball Name	Package Ball /Pin (Address)	Pin Mux Config Register
GPIO_31	U7	0xFFFFEA7C
GPIO_32	U6	0xFFFFEA80
GPIO_33	V5	0xFFFFEA84
GPIO_34	U5	0xFFFFEA88
GPIO_35	V3	0xFFFFEA8C
GPIO_36	M1	0xFFFFEA90
GPIO_37	L2	0xFFFFEA94
GPIO_38	L1	0xFFFFEA98
GPIO_39	C3	0xFFFFEA9C
GPIO_40	B3	0xFFFFEAA0
GPIO_41	C4	0xFFFFEAA4
GPIO_42	A3	0xFFFFEAA8
GPIO_43	B4	0xFFFFEAA C
GPIO_44	A4	0xFFFFEAB0
GPIO_45	C5	0xFFFFEAB4
GPIO_46	B5	0xFFFFEAB8
GPIO_47	U3	0xFFFFEABC
DMM_SYNC	U4	0xFFFFEAC0

The register layout is as follows:

**Table 6-3. PAD IO Register Bit Descriptions**

BIT	FIELD	TYPE	RESET (POWER ON DEFAULT)	DESCRIPTION
31-11	NU	RW	0	Reserved
10	SC	RW	0	IO slew rate control: 0 = Higher slew rate 1 = Lower slew rate
9	PUPDSEL	RW	0	Pullup/PullDown Selection 0 = Pull Down 1 = Pull Up (This field is valid only if Pull Inhibit is set as '0')
8	PI	RW	0	Pull Inhibit/Pull Disable 0 = Enable 1 = Disable
7	OE_OVERRIDE	RW	1	Output Override

**Table 6-3. PAD IO Register Bit Descriptions (continued)**

BIT	FIELD	TYPE	RESET (POWER ON DEFAULT)	DESCRIPTION
6	OE_OVERRIDE_CTRL	RW	1	Output Override Control: (A '1' here overrides any o/p manipulation of this IO by any of the peripheral block hardware it is associated with for example a SPI Chip select)
5	IE_OVERRIDE	RW	0	Input Override
4	IE_OVERRIDE_CTRL	RW	0	Input Override Control: (A '1' here overrides any i/p value on this IO with a desired value)
3-0	FUNC_SEL	RW	1	Function select for Pin Multiplexing (Refer to the Pin Mux Sheet)

## 7 Specifications

### 7.1 Absolute Maximum Ratings

PARAMETERS <sup>(1)</sup> <sup>(2)</sup>		MIN	MAX	UNIT
VDDIN	1.2 V digital power supply	-0.5	1.4	V
VIN_SRAM	1.2 V power rail for internal SRAM	-0.5	1.4	V
VNWA	1.2 V power rail for SRAM array back bias	-0.5	1.4	V
VIOIN	I/O supply (3.3 V or 1.8 V): All CMOS I/Os would operate on this supply.	-0.5	3.8	V
VIOIN_18	1.8 V supply for CMOS IO	-0.5	2	V
VIN_18CLK	1.8 V supply for clock module	-0.5	2	V
VIOIN_18DIFF	1.8 V supply for LVDS port	-0.5	2	V
VIN_13RF1	1.3 V Analog and RF supply, VIN_13RF1 and VIN_13RF2 could be shorted on the board.	-0.5	1.45	V
VIN_13RF2				
VIN_13RF1 (1-V Internal LDO bypass mode)	Device supports mode where external Power Management block can supply 1 V on VIN_13RF1 and VIN_13RF2 rails. In this configuration, the internal LDO of the device would be kept bypassed.	-0.5	1.4	V
VIN_13RF2 (1-V Internal LDO bypass mode)				
VIN_18BB	1.8-V Analog baseband power supply	-0.5	2	V
VIN_18VCO supply	1.8-V RF VCO supply	-0.5	2	V
Input and output voltage range	Dual-voltage LVCMOS inputs, 3.3 V or 1.8 V (Steady State)	-0.3V	VIOIN + 0.3	V
	Dual-voltage LVCMOS inputs, operated at 3.3 V/1.8 V (Transient Overshoot/Undershoot) or external oscillator input	VIOIN + 20% up to 20% of signal period		
CLKP, CLKM	Input ports for reference crystal	-0.5	2	V
Clamp current	Input or Output Voltages 0.3 V above or below their respective power rails. Limit clamp current that flows through the internal diode protection cells of the I/O.	-20	20	mA
T <sub>J</sub>	Operating junction temperature range	-40	125	°C
T <sub>STG</sub>	Storage temperature range after soldered onto PC board	-55	150	°C

- (1) Stresses beyond those listed under *Absolute Maximum Ratings* may cause permanent damage to the device. These are stress ratings only, and functional operation of the device at these or any other conditions beyond those indicated under *Recommended Operating Conditions* is not implied. Exposure to absolute-maximum-rated conditions for extended periods may affect device reliability.
- (2) All voltage values are with respect to V<sub>SS</sub>, unless otherwise noted.

### 7.2 ESD Ratings

		VALUE	UNIT
V <sub>(ESD)</sub>	Electrostatic discharge	Human-body model (HBM), per AEC Q100-002 <sup>(1)</sup>	±2000
		Charged-device model (CDM), per AEC Q100-011 <sup>(2)</sup>	±500

- (1) AEC Q100-002 indicates that HBM stressing shall be in accordance with the ANSI/ESDA/JEDEC JS-001 specification.
- (2) Corner pins are rated as ±750 V

### 7.3 Power-On Hours (POH)

JUNCTION TEMPERATURE (T <sub>J</sub> ) <sup>(1) (2)</sup>	OPERATING CONDITION	NOMINAL CVDD VOLTAGE (V)	POWER-ON HOURS [POH] (HOURS)
-40°C	100% duty cycle	1.2	600 (6%)
75°C			2000 (20%)
95°C			6500 (65%)
125°C			900 (9%)

- (1) This information is provided solely for your convenience and does not extend or modify the warranty provided under TI's standard terms and conditions for TI semiconductor products.
- (2) The specified POH are applicable with max Tx output power settings using the default firmware gain tables. The specified POH would not be applicable, if the Tx gain table is overwritten using an API.

## 7.4 Recommended Operating Conditions

		MIN	NOM	MAX	UNIT
VDDIN	1.2 V digital power supply	1.14	1.2	1.32	V
VIN_SRAM	1.2 V power rail for internal SRAM	1.14	1.2	1.32	V
VNWA	1.2 V power rail for SRAM array back bias	1.14	1.2	1.32	V
VIOIN	I/O supply (3.3 V or 1.8 V): All CMOS I/Os would operate on this supply.	3.13	3.3	3.45	V
		1.71	1.8	1.89	
VIOIN_18	1.8 V supply for CMOS IO	1.71	1.8	1.9	V
VIN_18CLK	1.8 V supply for clock module	1.71	1.8	1.9	V
VIOIN_18DIFF	1.8 V supply for LVDS port	1.71	1.8	1.9	V
VIN_13RF1	1.3 V Analog and RF supply. VIN_13RF1 and VIN_13RF2 could be shorted on the board	1.23	1.3	1.36	V
VIN_13RF2					
VIN_13RF1 (1-V Internal LDO bypass mode)		0.95	1	1.05	V
VIN_13RF2 (1-V Internal LDO bypass mode)					
VIN18BB	1.8-V Analog baseband power supply	1.71	1.8	1.9	V
VIN_18VCO	1.8V RF VCO supply	1.71	1.8	1.9	V
V <sub>IH</sub>	Voltage Input High (1.8 V mode)	1.17			V
	Voltage Input High (3.3 V mode)	2.25			
V <sub>IL</sub>	Voltage Input Low (1.8 V mode)			0.3*VIOIN	V
	Voltage Input Low (3.3 V mode)			0.62	
V <sub>OH</sub>	High-level output threshold (I <sub>OH</sub> = 6 mA)	VIOIN – 450			mV
V <sub>OL</sub>	Low-level output threshold (I <sub>OL</sub> = 6 mA)				450 mV
NRESET SOP[2:0]	V <sub>IL</sub> (1.8V Mode)			0.45	V
	V <sub>IH</sub> (1.8V Mode)	0.96			
	V <sub>IL</sub> (3.3V Mode)			0.65	
	V <sub>IH</sub> (3.3V Mode)	1.57			

## 7.5 VPP Specifications for One-Time Programmable (OTP) eFuses

This section specifies the operating conditions required for programming the OTP eFuses and is applicable only for authenticated boot devices. During the process of writing the customer specific keys or other fields like software version etc. in the efuse, the user needs to provide the VPP supply.

### 7.5.1 Recommended Operating Conditions for OTP eFuse Programming

PARAMETER	DESCRIPTION	MIN	NOM	MAX	UNIT
VPP	Supply voltage range for the eFuse ROM domain during normal operation		NC <sup>(2)</sup>		
	Supply voltage range for the eFuse ROM domain during OTP programming <sup>(1)</sup>	1.65	1.7	1.75	V
Duration of VPP Supply	If VPP voltage is supplied for more than recommended Hours, it can cause reliability issue			24	Hours
I(VPP)				50	mA

- (1) During normal operation, no voltage should be applied to VPP. This can be typically achieved by disabling the external regulator attached to the VPP terminal.  
 (2) NC: No Connect

#### Note

Power up sequence: VPP must be ramped up at the end i.e after all other rails ramp up is done

### 7.5.2 Hardware Requirements

The following hardware requirements must be met when programming keys in the OTP eFuses:

- The VPP power supply must be disabled when not programming OTP registers.

### 7.5.3 Impact to Your Hardware Warranty

You recognize and accept at your own risk that your use of eFuse permanently alters the TI device. You acknowledge that eFuse can fail due to incorrect operating conditions or programming sequence. Such a failure may render the TI device inoperable and TI will be unable to confirm the TI device conformed to TI device specifications prior to the attempted eFuse. CONSEQUENTLY, in these cases of faulty EFUSE programmability, TI WILL HAVE NO LIABILITY.

## 7.6 Power Supply Specifications

Table 7-1 describes the four rails from an external power supply block of the AWR6843AOP device.

**Table 7-1. Power Supply Rails Characteristics**

SUPPLY	DEVICE BLOCKS POWERED FROM THE SUPPLY	RELEVANT IOS IN THE DEVICE
1.8 V	Synthesizer and APLL VCOs, crystal oscillator, IF Amplifier stages, ADC, LVDS	Input: VIN_18VCO, VIN18CLK, VIN_18BB, VIOIN_18DIFF, VIOIN_18 LDO Output: VOUT_14SYNTH, VOUT_14APLL
1.3 V (or 1 V in internal LDO bypass mode) <sup>(1)</sup>	Power Amplifier, Low Noise Amplifier, Mixers and LO Distribution	Input: VIN_13RF2, VIN_13RF1 LDO Output: VOUT_PA
3.3 V (or 1.8 V for 1.8 V I/O mode)	Digital I/Os	Input VIOIN
1.2 V	Core Digital and SRAMs	Input: VDDIN, VIN_SRAM

- (1) Three simultaneous transmitter operation is supported only in 1-V LDO bypass and PA LDO disable mode. In this mode 1V supply needs to be fed on the VOUT PA pin.

The 1.3-V (1.0 V) and 1.8-V power supply ripple specifications mentioned in [Table 7-2](#) are defined to meet a target spur level of  $-105$  dBc (RF Pin =  $-15$  dBm) at the RX. The spur and ripple levels have a dB-to-dB relationship, for example, a 1-dB increase in supply ripple leads to a  $\sim 1$  dB increase in spur level. Values quoted are rms levels for a sinusoidal input applied at the specified frequency.

**Table 7-2. Ripple Specifications**

FREQUENCY (kHz)	RF RAIL		VCO/IF RAIL
	1.0 V (INTERNAL LDO BYPASS) ( $\mu\text{V}_{\text{RMS}}$ )	1.3 V ( $\mu\text{V}_{\text{RMS}}$ )	1.8 V ( $\mu\text{V}_{\text{RMS}}$ )
137.5	7	648	83
275	5	76	21
550	3	22	11
1100	2	4	6
2200	11	82	13
4400	13	93	19
6600	22	117	29

## 7.7 Power Consumption Summary

[Table 7-3](#) and [Table 7-4](#) summarize the power consumption at the power terminals.

**Table 7-3. Maximum Current Ratings at Power Terminals**

PARAMETER	SUPPLY NAME	DESCRIPTION	MIN	TYP	MAX	UNIT
Current consumption <sup>(1)</sup>	VDDIN, VIN_SRAM, VNWA	Total current drawn by all nodes driven by 1.2V rail			1000	mA
	VIN_13RF1, VIN_13RF2	Total current drawn by all nodes driven by 1.3V rail (or 1V rail in LDO Bypass mode), when only 2 transmitters are used. <sup>(3)</sup>			2000	
	VIOIN_18, VIN_18CLK, VIOIN_18DIFF, VIN_18BB, VIN_18VCO	Total current drawn by all nodes driven by 1.8V rail			850	
	VIOIN	Total current drawn by all nodes driven by 3.3V rail <sup>(2)</sup>			50	

(1) The specified current values are at typical supply voltage level.

(2) The exact VIOIN current depends on the peripherals used and their frequency of operation.

(3) Simultaneous 3 Transmitter operation is supported only with 1-V LDO bypass and PA LDO disable mode. In this mode, the 1-V supply needs to be fed on the VOUT\_PA pin. In this case, the peak 1-V supply current goes up to 2500 mA. To enable the LDO bypass mode, see the *Interface Control* document in the [mmWave software development kit \(SDK\)](#).

**Table 7-4. Average Power Consumption at Power Terminals**

PARAMETER	CONDITION		DESCRIPTION	MIN	TYP	MAX	UNIT
Average power consumption <sup>(1)</sup>	1.0-V internal LDO bypass mode	24% duty cycle	1TX, 4RX	Regular power ADC mode 6.4 Msps complex transceiver, 13.13-ms frame, 64 chirps, 256 samples/chirp, 8.5- $\mu\text{s}$ interchirp time, DSP + Hardware accelerator active	1.19		W
			2TX, 4RX <sup>(1)</sup>		1.25		
		48% duty cycle	1TX, 4RX	Regular power ADC mode 6.4 Msps complex transceiver, 13.13-ms frame, 64 chirps, 256 samples/chirp, 8.5- $\mu\text{s}$ interchirp time, DSP + Hardware accelerator active	1.62		
			2TX, 4RX <sup>(1)</sup>		1.75		

(1) Two TX antennas are on simultaneously.

### 7.8 Power Save Mode

xWR6x43 devices support 3 power down states:

1. RF Power Down state
2. APLL Power Down state

The allowed state transitions are shown in [Figure 7-1](#). This flow chart shows the sequence of steps for entering and exiting power save mode.

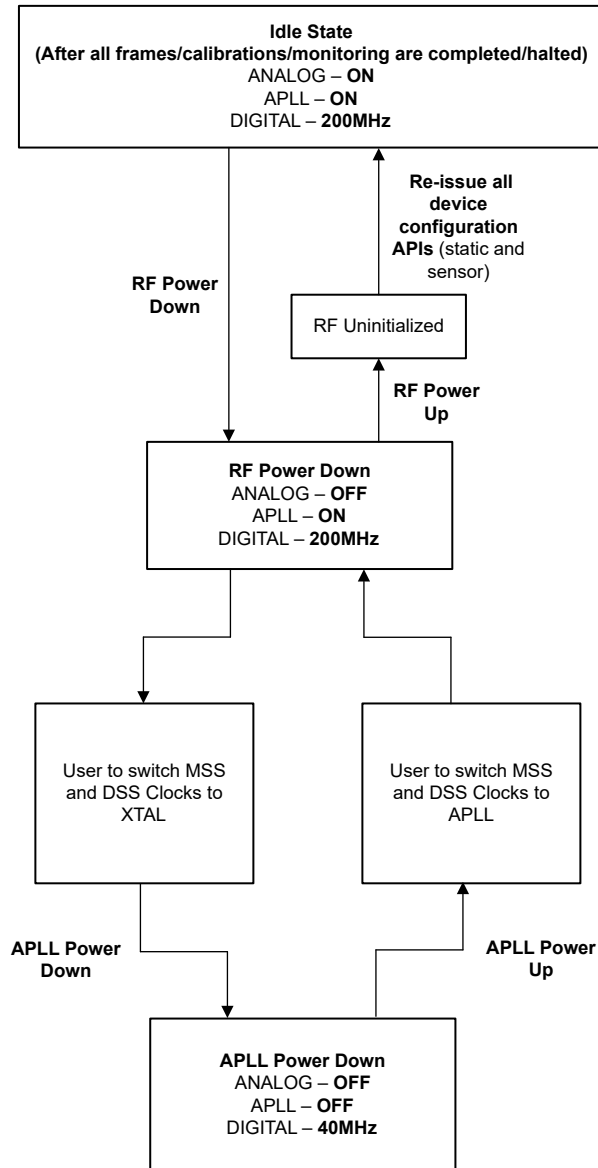

**Figure 7-1. Power Save Mode State Transition Diagram**

## 7.9 RF Specification

over recommended operating conditions (unless otherwise noted)

PARAMETER		MIN	TYP	MAX	UNIT
Receiver	Effective isotropic noise figure (EINF)	60 to 64 GHz		9	dB
	IF bandwidth <sup>(1)</sup>			10	MHz
	ADC sampling rate (real)			25	Msp/s
	ADC sampling rate (complex 1x)			12.5	Msp/s
	ADC resolution		12		Bits
	Idle Channel Spurs		-90		dBFS
Transmitter	Single transmitter effective isotropic radiated power (EIRP)		16		dBm
	Power backoff range		26		dB
Clock subsystem	Frequency range	60		64	GHz
	Ramp rate			250	MHz/μs
	Phase noise at 1-MHz offset	60 to 64 GHz		-93	dBc/Hz

- (1) The analog IF stages include high-pass filtering, with two independently configurable first-order high-pass corner frequencies. The set of available HPF corners is summarized as follows:

Available HPF Corner Frequencies (kHz)

HPF1	HPF2
175, 235, 350, 700	350, 700, 1400, 2800

The filtering performed by the digital baseband chain is targeted to provide:

- Less than ±0.5 dB pass-band ripple/droop, and
- Better than 60 dB anti-aliasing attenuation for any frequency that can alias back into the pass-band.

## 7.10 CPU Specifications

over recommended operating conditions (unless otherwise noted)

PARAMETER		MIN	TYP	MAX	UNIT
DSP Subsystem (C674 Family)	Clock Speed		600		MHz
	L1 Code Memory		32		KB
	L1 Data Memory		32		KB
	L2 Memory		256		KB
Main Subsystem (R4F Family)	Clock Speed		200		MHz
	Tightly Coupled Memory - A (Program)		512		KB
	Tightly Coupled Memory - B (Data)		192		KB
Shared Memory	Shared L3 Memory		768		KB

## 7.11 Thermal Resistance Characteristics for FCBGA Package [ALP0180A]

THERMAL METRICS <sup>(1)</sup>		°C/W <sup>(2) (3)</sup>
R $\theta_{JC}$	Junction-to-case	2.6
R $\theta_{JB}$	Junction-to-board	7.5
R $\theta_{JA}$	Junction-to-free air	20.3
R $\theta_{JMA}$	Junction-to-moving air	N/A <sup>(4)</sup>
Psi $_{JT}$	Junction-to-package top	0.9
Psi $_{JB}$	Junction-to-board	7.3

(1) For more information about traditional and new thermal metrics, see [Semiconductor and IC Package Thermal Metrics](#).

(2) °C/W = degrees Celsius per watt.

(3) These values are based on a JEDEC-defined 2S2P system (with the exception of the Theta JC [R $\theta_{JC}$ ] value, which is based on a JEDEC-defined 1S0P system) and will change based on environment as well as application. For more information, see these EIA/JEDEC standards:

- JESD51-2, *Integrated Circuits Thermal Test Method Environmental Conditions - Natural Convection (Still Air)*
- JESD51-3, *Low Effective Thermal Conductivity Test Board for Leaded Surface Mount Packages*
- JESD51-7, *High Effective Thermal Conductivity Test Board for Leaded Surface Mount Packages*
- JESD51-9, *Test Boards for Area Array Surface Mount Package Thermal Measurements*

(4) N/A = not applicable. Heatsink on this device.

## 7.12 Timing and Switching Characteristics

### 7.12.1 Antenna Radiation Patterns

This section discusses transmitter and receiver antenna radiation patterns in both Azimuth and Elevation planes for a specified frequency.

#### 7.12.1.1 Antenna Radiation Patterns for Receiver

[Figure 7-2](#) shows typical antenna radiation gain plots normalized to boresight at various frequencies for the four receivers in both Azimuth (H-Plane) and Elevation (E-Plane) planes

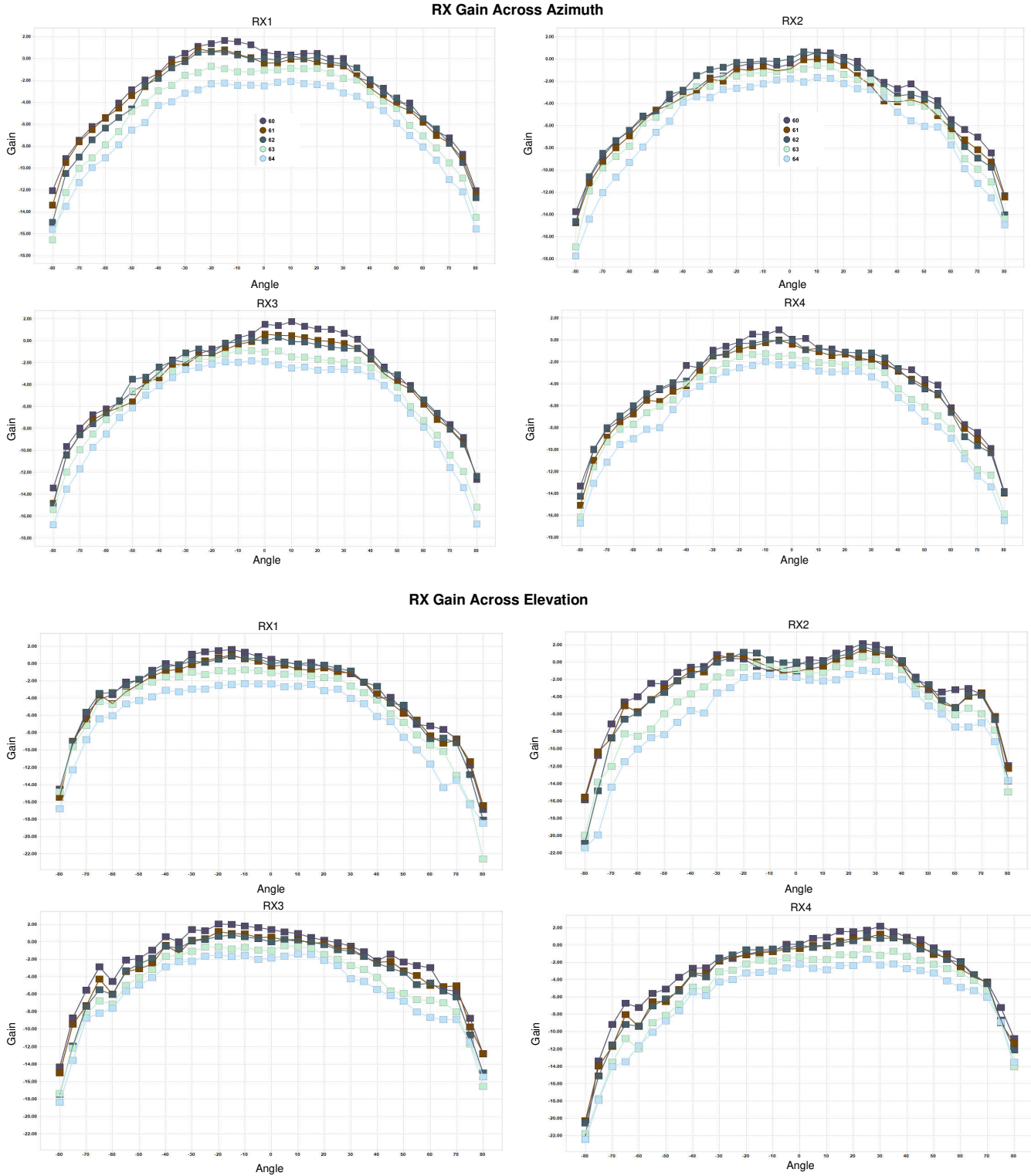

**Figure 7-2. Receiver Antenna Radiation Pattern**

### 7.12.1.2 Antenna Radiation Patterns for Transmitter

Figure 7-3 shows typical antenna radiation patterns for the three transmitters in both Azimuth and Elevation planes.

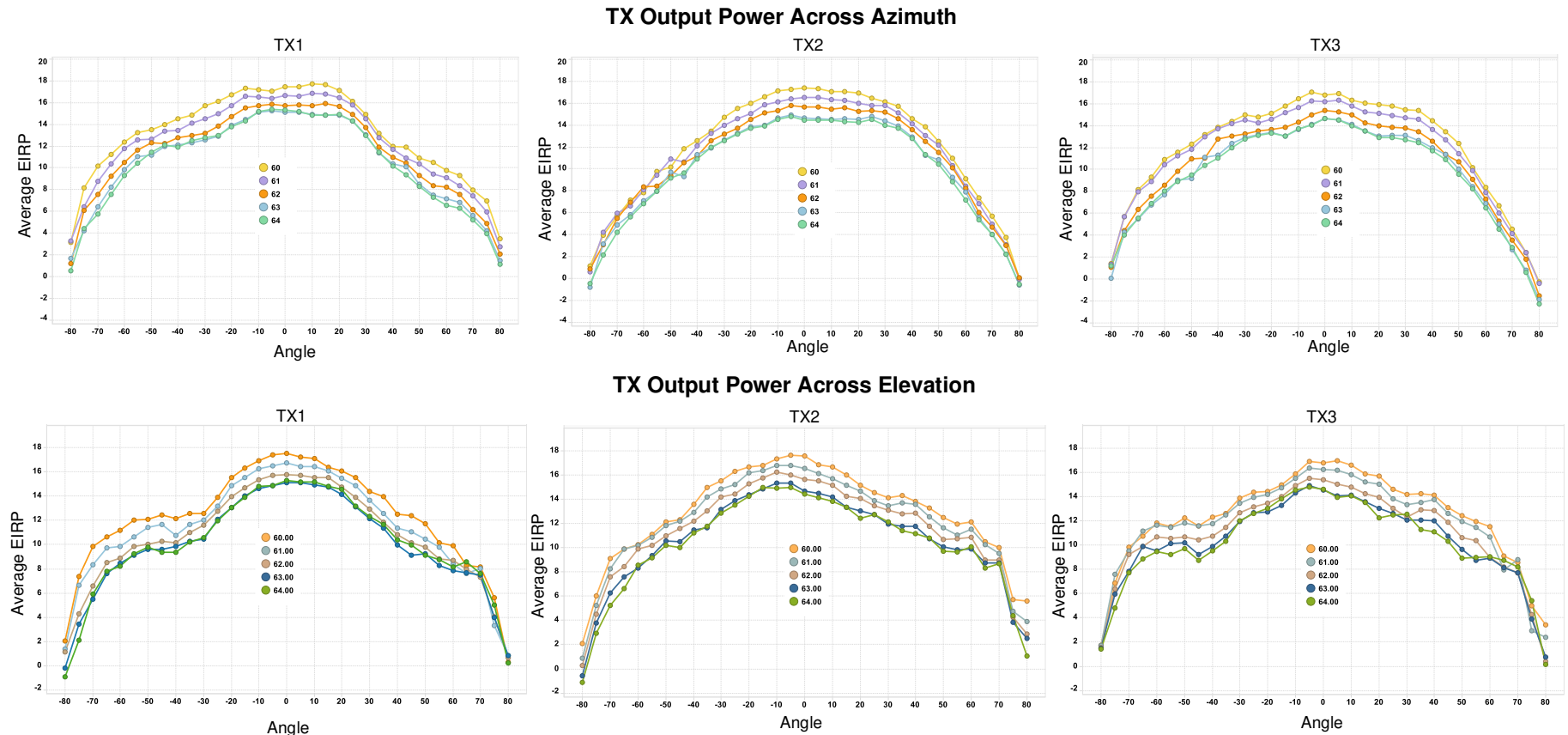
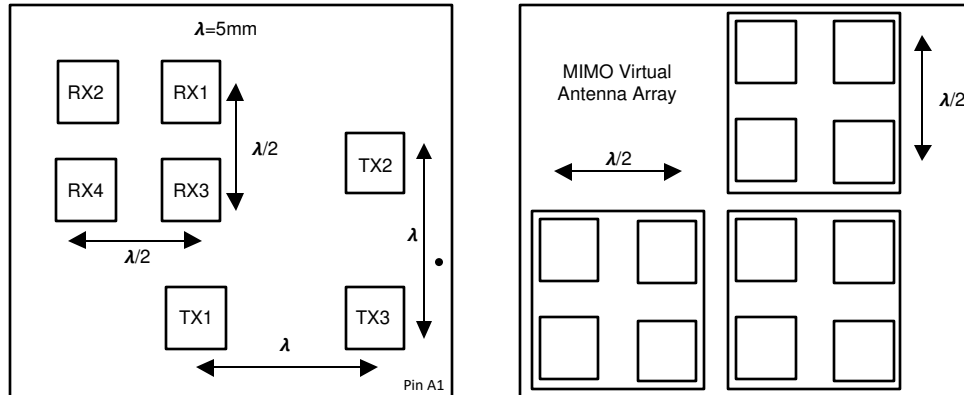

Figure 7-3. Transmitter Antenna Radiation Pattern

### 7.12.2 Antenna Positions

Figure 7-4 shows the placement and relative spacing of the antennas.



**Figure 7-4. Antenna Positions (Placement and Relative Spacing)**

### 7.12.3 Power Supply Sequencing and Reset Timing

The AWR6843AOP device expects all external voltage rails to be stable before reset is deasserted. Figure 7-5 describes the device wake-up sequence.

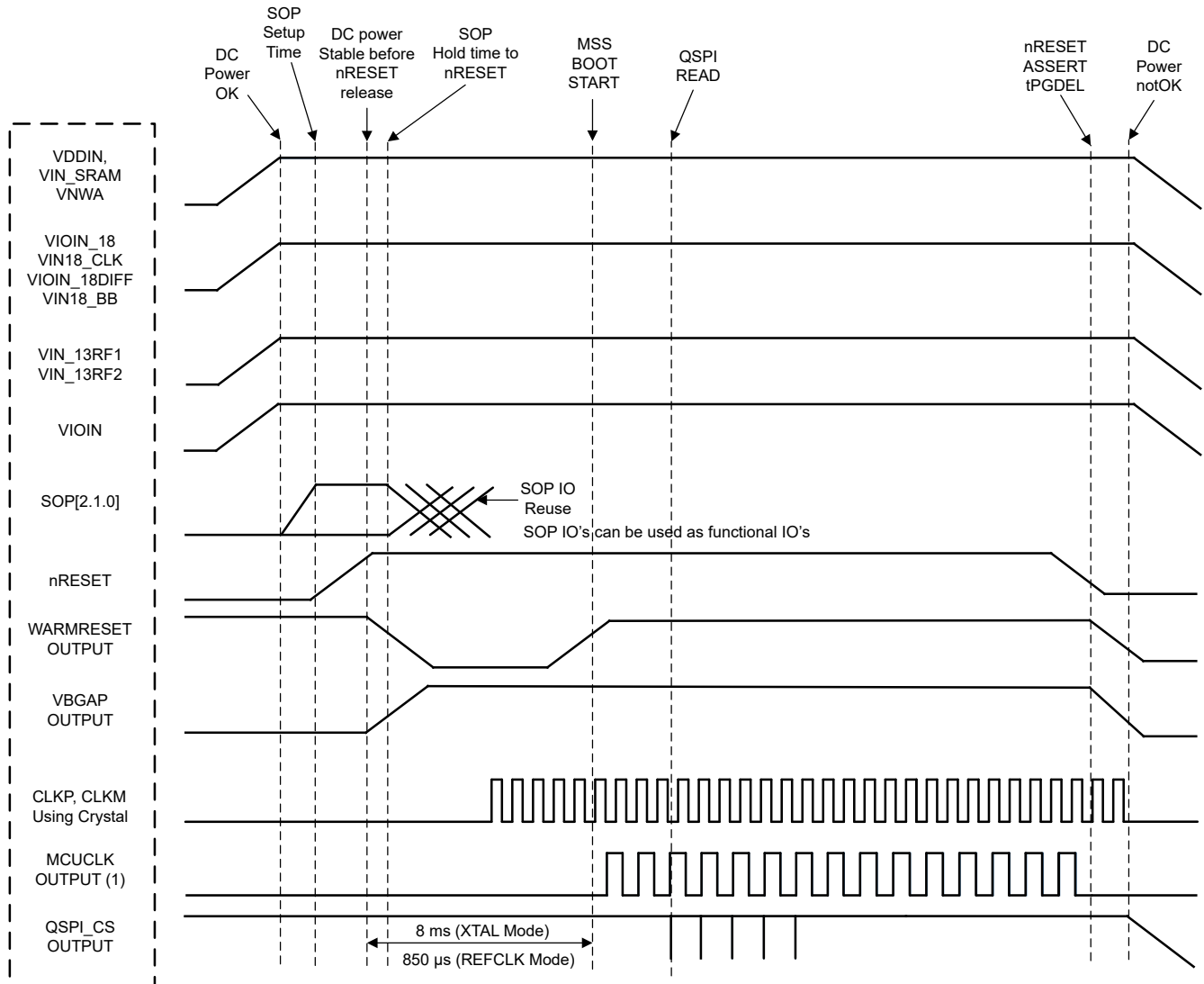

- A. MCU\_CLK\_OUT in autonomous mode, where AWR6843AOP application is booted from the serial flash, MCU\_CLK\_OUT is not enabled by default by the device bootloader.

**Figure 7-5. Device Wake-up Sequence**

## 7.12.4 Input Clocks and Oscillators

### 7.12.4.1 Clock Specifications

The AWR6843AOP requires external clock source (that is, a 40-MHz crystal or external oscillator to CLKP) for initial boot and as a reference for an internal APLL hosted in the device. An external crystal is connected to the device pins. [Figure 7-6](#) shows the crystal implementation.

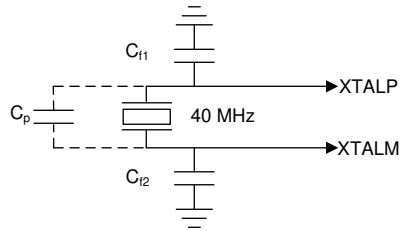

**Figure 7-6. Crystal Implementation**

#### Note

The load capacitors,  $C_{f1}$  and  $C_{f2}$  in [Figure 7-6](#), should be chosen such that [Equation 1](#) is satisfied.  $C_L$  in the equation is the load specified by the crystal manufacturer. All discrete components used to implement the oscillator circuit should be placed as close as possible to the associated oscillator CLKP and CLKM pins.

$$C_L = C_{f1} \times \frac{C_{f2}}{C_{f1} + C_{f2}} + C_P \quad (1)$$

[Table 7-5](#) lists the electrical characteristics of the clock crystal.

**Table 7-5. Crystal Electrical Characteristics (Oscillator Mode)**

NAME	DESCRIPTION	MIN	TYP	MAX	UNIT
$f_p$	Parallel resonance crystal frequency		40		MHz
$C_L$	Crystal load capacitance	5	8	12	pF
ESR	Crystal ESR			50	$\Omega$
Temperature range	Expected temperature range of operation	-40		125	$^{\circ}\text{C}$
Frequency tolerance	Crystal frequency tolerance <sup>(1) (2) (3)</sup>	-200		200	ppm
Drive level			50	200	$\mu\text{W}$

- (1) The crystal manufacturer's specification must satisfy this requirement.
- (2) Includes initial tolerance of the crystal, drift over temperature, aging and frequency pulling due to incorrect load capacitance.
- (3) Crystal tolerance affects radar sensor accuracy.

In the case where an external clock is used as the clock resource, the signal is fed to the CLKP pin only; CLKM is grounded. The phase noise requirement is very important when a 40-MHz clock is fed externally. [Table 7-6](#) lists the electrical characteristics of the external clock signal.

**Table 7-6. External Clock Mode Specifications**

PARAMETER		SPECIFICATION			UNIT
		MIN	TYP	MAX	
Input Clock: External AC-coupled sine wave or DC- coupled square wave Phase Noise referred to 40 MHz	Frequency		40		MHz
	AC-Amplitude	700		1200	mV (pp)
	DC- $V_{il}$	0.00		0.20	V
	DC- $V_{ih}$	1.6		1.95	V
	Phase Noise at 1 kHz			-132	dBc/Hz
	Phase Noise at 10 kHz			-143	dBc/Hz
	Phase Noise at 100 kHz			-152	dBc/Hz
	Phase Noise at 1 MHz			-153	dBc/Hz
	Duty Cycle	35		65	%
	Freq Tolerance	-100		100	ppm

## 7.12.5 Multibuffered / Standard Serial Peripheral Interface (MibSPI)

### 7.12.5.1 Peripheral Description

The SPI uses a MibSPI Protocol by TI.

The MibSPI/SPI is a high-speed synchronous serial input/output port that allows a serial bit stream of programmed length (2 to 16 bits) to be shifted into and out of the device at a programmed bit-transfer rate. The MibSPI/SPI is normally used for communication between the microcontroller and external peripherals or another microcontroller.

Standard and MibSPI modules have the following features:

- 16-bit shift register
- Receive buffer register
- 8-bit baud clock generator
- SPICLK can be internally-generated (master mode) or received from an external clock source (slave mode)
- Each word transferred can have a unique format.
- SPI I/Os not used in the communication can be used as digital input/output signals

### 7.12.5.2 MibSPI Transmit and Receive RAM Organization

The Multibuffer RAM is comprised of 256 buffers. Each entry in the Multibuffer RAM consists of 4 parts: a 16-bit transmit field, a 16-bit receive field, a 16-bit control field and a 16-bit status field. The Multibuffer RAM can be partitioned into multiple transfer group with variable number of buffers each.

[Section 7.12.5.2.2](#) and [Section 7.12.5.2.3](#) assume the operating conditions stated in [Section 7.12.5.2.1](#).

#### 7.12.5.2.1 SPI Timing Conditions

		MIN	TYP	MAX	UNIT
Input Conditions					
$t_R$	Input rise time	1		3	ns
$t_F$	Input fall time	1		3	ns
Output Conditions					
$C_{LOAD}$	Output load capacitance	2		15	pF

**7.12.5.2.2 SPI Controller Mode Switching Parameters (CLOCK PHASE = 0, SPICLK = output, SPISIMO = output, and SPISOMI = input)**

NO. (1) (2) (3)	PARAMETER		MIN	TYP	MAX	UNIT
1	$t_{c(SPC)M}$	Cycle time, SPICLK <sup>(4)</sup>	25		$256t_{c(VCLK)}$	ns
2 <sup>(4)</sup>	$t_{w(SPCH)M}$	Pulse duration, SPICLK high (clock polarity = 0)	$0.5t_{c(SPC)M} - 4$		$0.5t_{c(SPC)M} + 4$	ns
	$t_{w(SPCL)M}$	Pulse duration, SPICLK low (clock polarity = 1)	$0.5t_{c(SPC)M} - 4$		$0.5t_{c(SPC)M} + 4$	
3 <sup>(4)</sup>	$t_{w(SPCL)M}$	Pulse duration, SPICLK low (clock polarity = 0)	$0.5t_{c(SPC)M} - 4$		$0.5t_{c(SPC)M} + 4$	ns
	$t_{w(SPCH)M}$	Pulse duration, SPICLK high (clock polarity = 1)	$0.5t_{c(SPC)M} - 4$		$0.5t_{c(SPC)M} + 4$	
4 <sup>(4)</sup>	$t_{d(SPCH-SIMO)M}$	Delay time, SPISIMO valid before SPICLK low, (clock polarity = 0)	$0.5t_{c(SPC)M} - 3$			ns
	$t_{d(SPCL-SIMO)M}$	Delay time, SPISIMO valid before SPICLK high, (clock polarity = 1)	$0.5t_{c(SPC)M} - 3$			
5 <sup>(4)</sup>	$t_{v(SPCL-SIMO)M}$	Valid time, SPISIMO data valid after SPICLK low, (clock polarity = 0)	$0.5t_{c(SPC)M} - 10.5$			ns
	$t_{v(SPCH-SIMO)M}$	Valid time, SPISIMO data valid after SPICLK high, (clock polarity = 1)	$0.5t_{c(SPC)M} - 10.5$			
6 <sup>(5)</sup>	$t_{C2TDELAY}$	Setup time CS active until SPICLK high (clock polarity = 0)	CSHOLD = 0	$(C2TDELAY+2)*t_{c(VCLK)} - 7.5$	$(C2TDELAY+2)*t_{c(VCLK)} + 7$	ns
			CSHOLD = 1	$(C2TDELAY + 3)*t_{c(VCLK)} - 7.5$	$(C2TDELAY+3)*t_{c(VCLK)} + 7$	
		Setup time CS active until SPICLK low (clock polarity = 1)	CSHOLD = 0	$(C2TDELAY+2)*t_{c(VCLK)} - 7.5$	$(C2TDELAY+2)*t_{c(VCLK)} + 7$	
			CSHOLD = 1	$(C2TDELAY + 3)*t_{c(VCLK)} - 7.5$	$(C2TDELAY+3)*t_{c(VCLK)} + 7$	
7 <sup>(5)</sup>	$t_{T2CDELAY}$	Hold time, SPICLK low until CS inactive (clock polarity = 0)	$0.5*t_{c(SPC)M} + (T2CDELAY + 1)*t_{c(VCLK)} - 7$	$0.5*t_{c(SPC)M} + (T2CDELAY + 1)*t_{c(VCLK)} + 7.5$	ns	
		Hold time, SPICLK high until CS inactive (clock polarity = 1)	$0.5*t_{c(SPC)M} + (T2CDELAY + 1)*t_{c(VCLK)} - 7$	$0.5*t_{c(SPC)M} + (T2CDELAY + 1)*t_{c(VCLK)} + 7.5$		
8 <sup>(4)</sup>	$t_{su(SOMI-SPCL)M}$	Setup time, SPISOMI before SPICLK low (clock polarity = 0)	5			ns
	$t_{su(SOMI-SPCH)M}$	Setup time, SPISOMI before SPICLK high (clock polarity = 1)	5			
9 <sup>(4)</sup>	$t_{h(SPCL-SOMI)M}$	Hold time, SPISOMI data valid after SPICLK low (clock polarity = 0)	3			ns
	$t_{h(SPCH-SOMI)M}$	Hold time, SPISOMI data valid after SPICLK high (clock polarity = 1)	3			

(1) The MASTER bit (SPIGCRx.0) is set and the CLOCK PHASE bit (SPIFMTx.16) is cleared (where x= 0 or 1).

(2)  $t_{c(MSS\_VCLK)}$  = main subsystem clock time =  $1 / f_{(MSS\_VCLK)}$ . For more details, see the [Technical Reference Manual](#).

(3) When the SPI is in Controller mode, the following must be true: For PS values from 1 to 255:  $t_{c(SPC)M} \geq (PS + 1)t_{c(MSS\_VCLK)} \geq 25ns$ , where PS is the prescale value set in the SPIFMTx.[15:8] register bits. For PS values of 0:  $t_{c(SPC)M} = 2t_{c(MSS\_VCLK)} \geq 25ns$ .

(4) The active edge of the SPICLK signal referenced is controlled by the CLOCK POLARITY bit (SPIFMTx.17).

(5) C2TDELAY and T2CDELAY is programmed in the SPIDELAY register

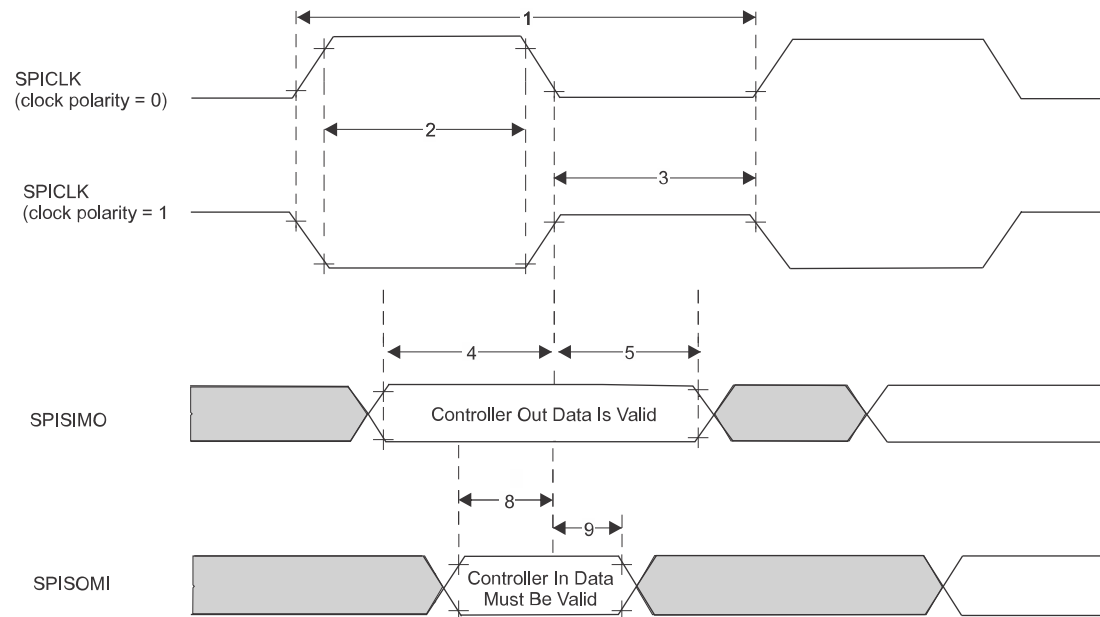

**Figure 7-7. SPI Controller Mode External Timing (CLOCK PHASE = 0)**

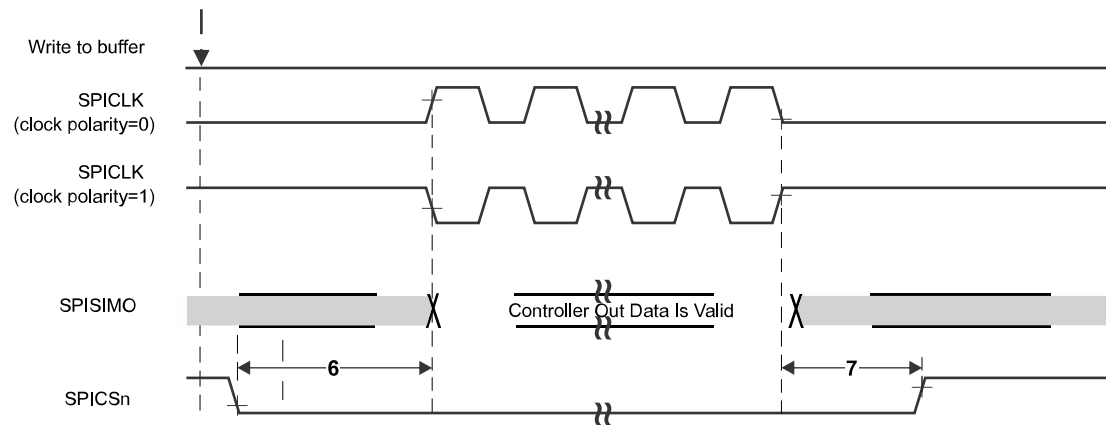

**Figure 7-8. SPI Controller Mode Chip Select Timing (CLOCK PHASE = 0)**

**7.12.5.2.3 SPI Controller Mode Switching Parameters (CLOCK PHASE = 1, SPICLK = output, SPISIMO = output, and SPISOMI = input)**

NO. (1) (2) (3)	PARAMETER		MIN	TYP	MAX	UNIT
1	$t_{c(SPC)M}$	Cycle time, SPICLK <sup>(4)</sup>	25		$256t_{c(VCLK)}$	ns
2 <sup>(4)</sup>	$t_{w(SPCH)M}$	Pulse duration, SPICLK high (clock polarity = 0)	$0.5t_{c(SPC)M} - 4$		$0.5t_{c(SPC)M} + 4$	ns
	$t_{w(SPCL)M}$	Pulse duration, SPICLK low (clock polarity = 1)	$0.5t_{c(SPC)M} - 4$		$0.5t_{c(SPC)M} + 4$	
3 <sup>(4)</sup>	$t_{w(SPCL)M}$	Pulse duration, SPICLK low (clock polarity = 0)	$0.5t_{c(SPC)M} - 4$		$0.5t_{c(SPC)M} + 4$	ns
	$t_{w(SPCH)M}$	Pulse duration, SPICLK high (clock polarity = 1)	$0.5t_{c(SPC)M} - 4$		$0.5t_{c(SPC)M} + 4$	
4 <sup>(4)</sup>	$t_{d(SPCH-SIMO)M}$	Delay time, SPISIMO valid before SPICLK low, (clock polarity = 0)	$0.5t_{c(SPC)M} - 3$			ns
	$t_{d(SPCL-SIMO)M}$	Delay time, SPISIMO valid before SPICLK high, (clock polarity = 1)	$0.5t_{c(SPC)M} - 3$			
5 <sup>(4)</sup>	$t_{v(SPCL-SIMO)M}$	Valid time, SPISIMO data valid after SPICLK low, (clock polarity = 0)	$0.5t_{c(SPC)M} - 10.5$			ns
	$t_{v(SPCH-SIMO)M}$	Valid time, SPISIMO data valid after SPICLK high, (clock polarity = 1)	$0.5t_{c(SPC)M} - 10.5$			
6 <sup>(5)</sup>	$t_{C2TDELAY}$	Setup time CS active until SPICLK high (clock polarity = 0)	CSHOLD = 0	$0.5*t_{c(SPC)M} + (C2TDELAY + 2)*t_{c(VCLK)} - 7$	$0.5*t_{c(SPC)M} + (C2TDELAY+2) * t_{c(VCLK)} + 7.5$	ns
			CSHOLD = 1	$0.5*t_{c(SPC)M} + (C2TDELAY + 2)*t_{c(VCLK)} - 7$	$0.5*t_{c(SPC)M} + (C2TDELAY+2) * t_{c(VCLK)} + 7.5$	
	Setup time CS active until SPICLK low (clock polarity = 1)	CSHOLD = 0	$0.5*t_{c(SPC)M} + (C2TDELAY+2)*t_{c(VCLK)} - 7$	$0.5*t_{c(SPC)M} + (C2TDELAY+2) * t_{c(VCLK)} + 7.5$		
		CSHOLD = 1	$0.5*t_{c(SPC)M} + (C2TDELAY+3)*t_{c(VCLK)} - 7$	$0.5*t_{c(SPC)M} + (C2TDELAY+3) * t_{c(VCLK)} + 7.5$		
7 <sup>(5)</sup>	$t_{T2CDELAY}$	Hold time, SPICLK low until CS inactive (clock polarity = 0)	$(T2CDELAY + 1) * t_{c(VCLK)} - 7.5$	$(T2CDELAY + 1) * t_{c(VCLK)} + 7$	ns	
		Hold time, SPICLK high until CS inactive (clock polarity = 1)	$(T2CDELAY + 1) * t_{c(VCLK)} - 7.5$	$(T2CDELAY + 1) * t_{c(VCLK)} + 7$		
8 <sup>(4)</sup>	$t_{su(SOMI-SPCL)M}$	Setup time, SPISOMI before SPICLK low (clock polarity = 0)	5			ns
	$t_{su(SOMI-SPCH)M}$	Setup time, SPISOMI before SPICLK high (clock polarity = 1)	5			
9 <sup>(4)</sup>	$t_{h(SPCL-SOMI)M}$	Hold time, SPISOMI data valid after SPICLK low (clock polarity = 0)	3			ns
	$t_{h(SPCH-SOMI)M}$	Hold time, SPISOMI data valid after SPICLK high (clock polarity = 1)	3			

(1) The MASTER bit (SPIGCRx.0) is set and the CLOCK PHASE bit (SPIFMTx.16) is set ( where x = 0 or 1 ).

(2)  $t_{c(MSS\_VCLK)}$  = main subsystem clock time =  $1 / f_{(MSS\_VCLK)}$ . For more details, see the [Technical Reference Manual](#).

- (3) When the SPI is in Controller mode, the following must be true: For PS values from 1 to 255:  $t_{c(SPC)M} \geq (PS + 1)t_{c(MSS\_VCLK)} \geq 25 \text{ ns}$ , where PS is the prescale value set in the SPIFMTx.[15:8] register bits. For PS values of 0:  $t_{c(SPC)M} = 2t_{c(MSS\_VCLK)} \geq 25 \text{ ns}$ .
- (4) The active edge of the SPICLK signal referenced is controlled by the CLOCK POLARITY bit (SPIFMTx.17).
- (5) C2DELAY and T2CDELAY is programmed in the SPIDELAY register

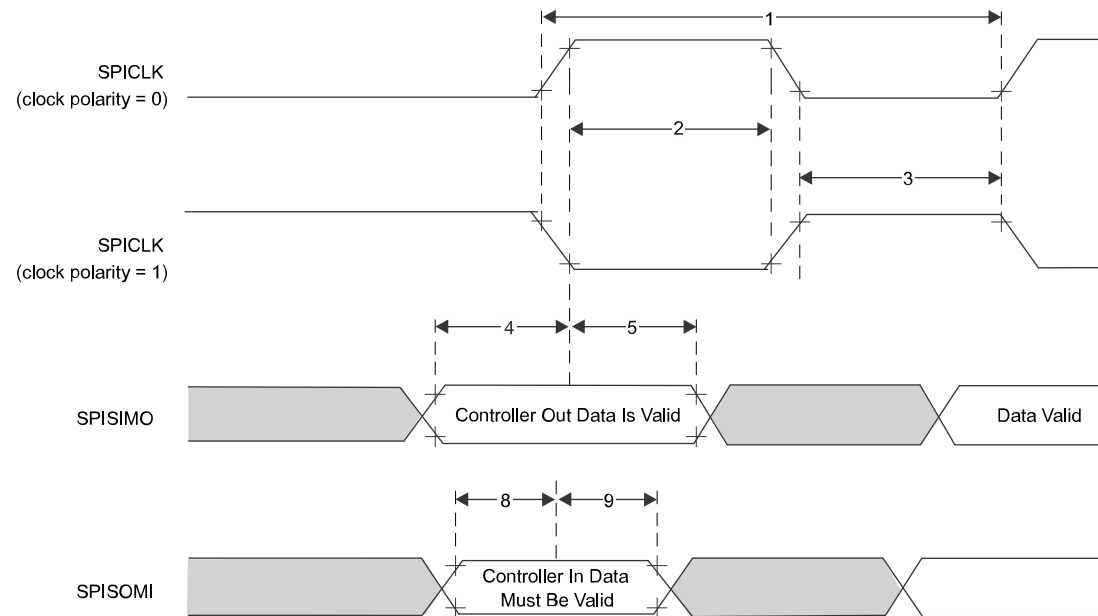

**Figure 7-9. SPI Controller Mode External Timing (CLOCK PHASE = 1)**

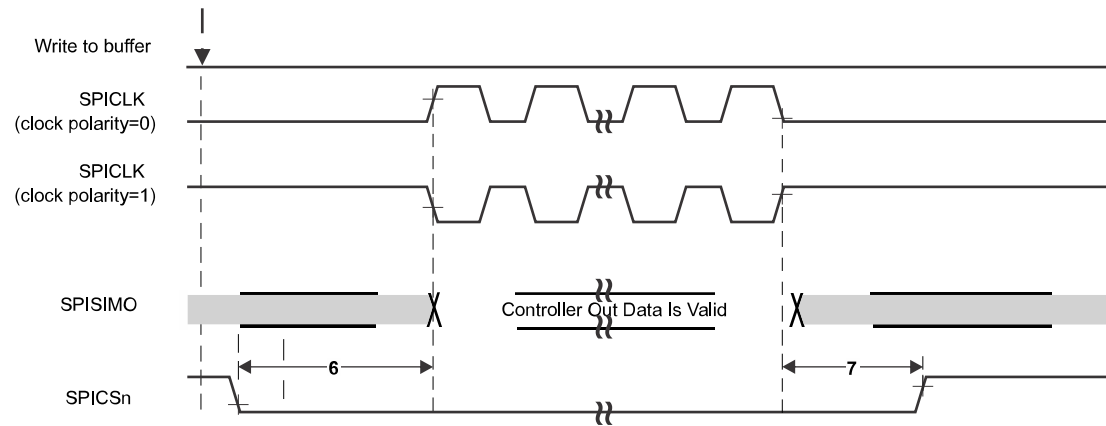

**Figure 7-10. SPI Controller Mode Chip Select Timing (CLOCK PHASE = 1)**

### 7.12.5.3 SPI Peripheral Mode I/O Timings

#### 7.12.5.3.1 SPI Peripheral Mode Switching Parameters (SPICLK = input, SPISIMO = input, and SPISOMI = output) <sup>(1)</sup> <sup>(2)</sup> <sup>(3)</sup>

NO.	PARAMETER		MIN	TYP	MAX	UNIT
1	$t_{c(SPC)}S$	Cycle time, SPICLK <sup>(4)</sup>	25			ns
2 <sup>(5)</sup>	$t_w(SPCH)S$	Pulse duration, SPICLK high (clock polarity = 0)	10			ns
	$t_w(SPCL)S$	Pulse duration, SPICLK low (clock polarity = 1)	10			
3 <sup>(5)</sup>	$t_w(SPCL)S$	Pulse duration, SPICLK low (clock polarity = 0)	10			ns
	$t_w(SPCH)S$	Pulse duration, SPICLK high (clock polarity = 1)	10			
4 <sup>(5)</sup>	$t_d(SPCH-SOMI)S$	Delay time, SPISOMI valid after SPICLK high (clock polarity = 0)			10	ns
	$t_d(SPCL-SOMI)S$	Delay time, SPISOMI valid after SPICLK low (clock polarity = 1)			10	
5 <sup>(5)</sup>	$t_h(SPCH-SOMI)S$	Hold time, SPISOMI data valid after SPICLK high (clock polarity = 0)	2			ns
	$t_h(SPCL-SOMI)S$	Hold time, SPISOMI data valid after SPICLK low (clock polarity = 1)	2			

- (1) The MASTER bit (SPIGCRx.0) is cleared ( where x = 0 or 1 ).
- (2) The CLOCK PHASE bit (SPIFMTx.16) is either cleared or set for CLOCK PHASE = 0 or CLOCK PHASE = 1 respectively.
- (3)  $t_{c(MSS\_VCLK)}$  = main subsystem clock time =  $1 / f_{(MSS\_VCLK)}$ . For more details, see the [Technical Reference Manual](#).
- (4) When the SPI is in Peripheral mode, the following must be true: For PS values from 1 to 255:  $t_{c(SPC)}S \geq (PS + 1)t_{c(MSS\_VCLK)} \geq 25$  ns, where PS is the prescale value set in the SPIFMTx.[15:8] register bits. For PS values of 0:  $t_{c(SPC)}S = 2t_{c(MSS\_VCLK)} \geq 25$  ns.
- (5) The active edge of the SPICLK signal referenced is controlled by the CLOCK POLARITY bit (SPIFMTx.17).

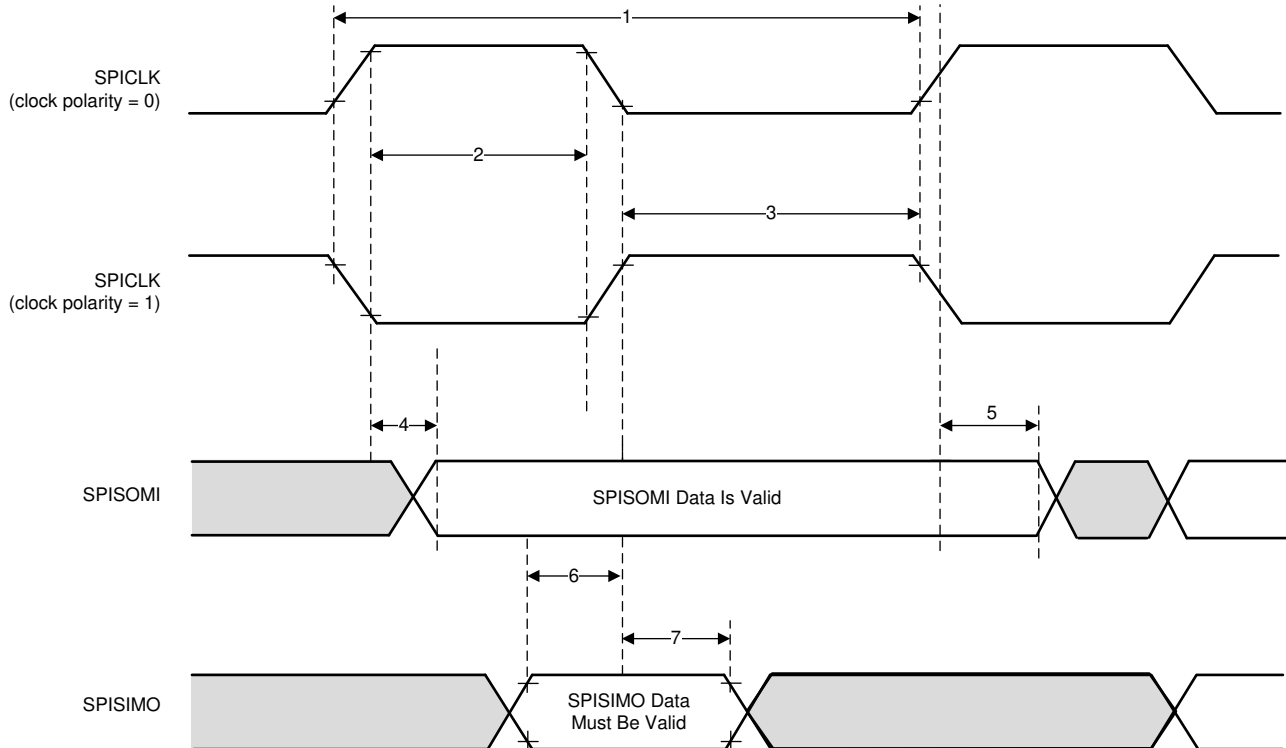

**Figure 7-11. SPI Peripheral Mode External Timing (CLOCK PHASE = 0)**

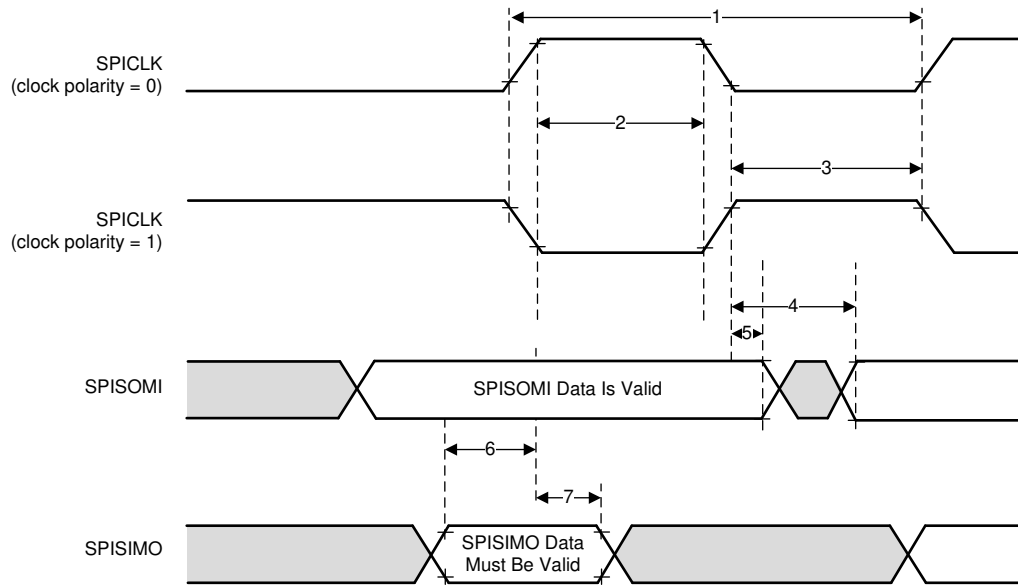
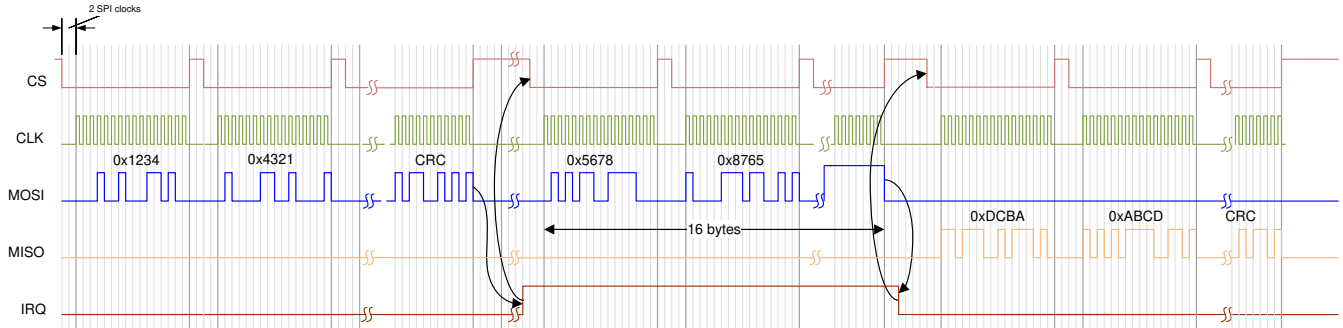

**Figure 7-12. SPI Peripheral Mode External Timing (CLOCK PHASE = 1)**

### 7.12.5.4 Typical Interface Protocol Diagram (Peripheral Mode)

1. Host should ensure that there is a delay of two SPI clocks between CS going low and start of SPI clock.
2. Host should ensure that CS is toggled for every 16 bits of transfer through SPI.

Figure 7-13 shows the SPI communication timing of the typical interface protocol.



**Figure 7-13. SPI Communication**

### 7.12.6 LVDS Interface Configuration

The supported AWR6843AOP LVDS lane configuration is two Data lanes (LVDS\_TXP/M), one Bit Clock lane (LVDS\_CLKP/M) and one Frame clock lane (LVDS\_FRCLKP/M). The LVDS interface is used for debugging. The LVDS interface supports the following data rates:

- 900 Mbps (450 MHz DDR Clock)
- 600 Mbps (300 MHz DDR Clock)
- 450 Mbps (225 MHz DDR Clock)
- 400 Mbps (200 MHz DDR Clock)
- 300 Mbps (150 MHz DDR Clock)
- 225 Mbps (112.5 MHz DDR Clock)
- 150 Mbps (75 MHz DDR Clock)

Note that the bit clock is in DDR format and hence the numbers of toggles in the clock is equivalent to data.

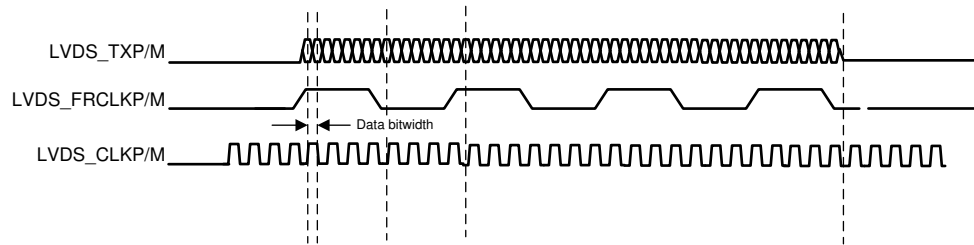
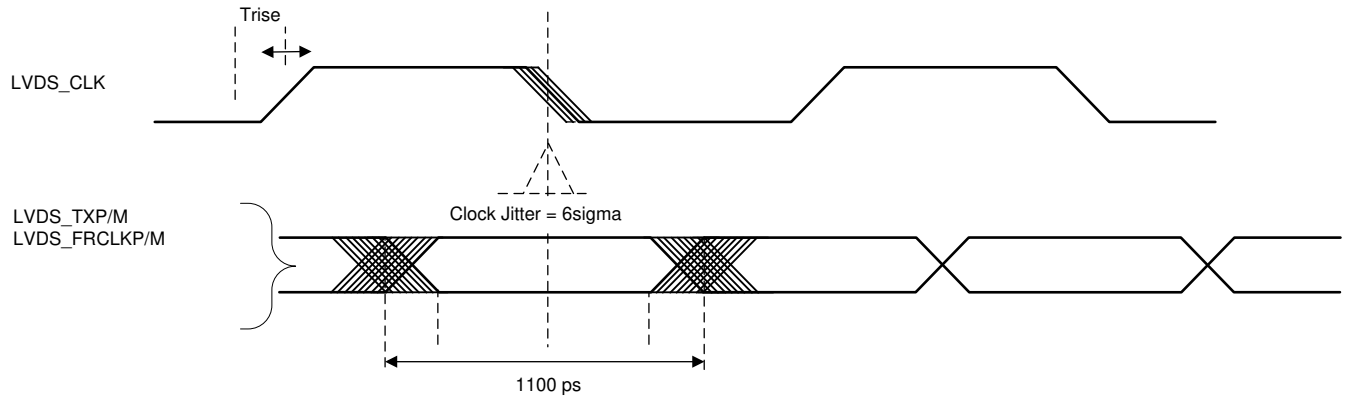

Figure 7-14. LVDS Interface Lane Configuration And Relative Timings

#### 7.12.6.1 LVDS Interface Timings

Table 7-7. LVDS Electrical Characteristics

PARAMETER	TEST CONDITIONS	MIN	TYP	MAX	UNIT
Duty Cycle Requirements	max 1 pF lumped capacitive load on LVDS lanes	48%		52%	
Output Differential Voltage	peak-to-peak single-ended with 100 $\Omega$ resistive load between differential pairs	250		450	mV
Output Offset Voltage		1125		1275	mV
Trise and Tfall	20%-80%, 900 Mbps		330		ps
Jitter (pk-pk)	900 Mbps		80		ps



**Figure 7-15. Timing Parameters**

### 7.12.7 General-Purpose Input/Output

Section 7.12.7.1 lists the switching characteristics of output timing relative to load capacitance.

#### 7.12.7.1 Switching Characteristics for Output Timing versus Load Capacitance ( $C_L$ )

PARAMETER <sup>(1) (2)</sup>		TEST CONDITIONS	VIOIN = 1.8V	VIOIN = 3.3V	UNIT	
$t_r$	Max rise time	Slew control = 0	$C_L = 20$ pF	2.8	3.0	ns
			$C_L = 50$ pF	6.4	6.9	
			$C_L = 75$ pF	9.4	10.2	
$t_f$	Max fall time		$C_L = 20$ pF	2.8	2.8	ns
			$C_L = 50$ pF	6.4	6.6	
			$C_L = 75$ pF	9.4	9.8	
$t_r$	Max rise time	Slew control = 1	$C_L = 20$ pF	3.3	3.3	ns
			$C_L = 50$ pF	6.7	7.2	
			$C_L = 75$ pF	9.6	10.5	
$t_f$	Max fall time		$C_L = 20$ pF	3.1	3.1	ns
			$C_L = 50$ pF	6.6	6.6	
			$C_L = 75$ pF	9.6	9.6	

(1) Slew control, which is configured by PADxx\_CFG\_REG, changes behavior of the output driver (faster or slower output slew rate).

(2) The rise/fall time is measured as the time taken by the signal to transition from 10% and 90% of VIOIN voltage.

### 7.12.8 Controller Area Network - Flexible Data-rate (CAN-FD)

The device integrates two CAN-FD (CAN with Flexible Data-rate) interfaces which allows high throughput and increased payload per data frame. This enables support of a typical use case where one CAN-FD interface is used as an ECU network interface while the other as a local network interface, providing communication with the neighboring sensors.

The CAN-FD has the following features:

- Conforms with CAN Protocol 2.0 A, B and ISO 11898-1
- Full CAN FD support (up to 64 data bytes per frame)
- AUTOSAR and SAE J1939 support
- Up to 32 dedicated Transmit Buffers
- Configurable Transmit FIFO, up to 32 elements
- Configurable Transmit Queue, up to 32 elements
- Configurable Transmit Event FIFO, up to 32 elements
- Up to 64 dedicated Receive Buffers
- Two configurable Receive FIFOs, up to 64 elements each
- Up to 128 11-bit filter elements
- Internal Loopback mode for self-test
- Mask-able interrupts, two interrupt lines
- Two clock domains (CAN clock / Host clock)
- Parity / ECC support - Message RAM single error correction and double error detection (SECDED) mechanism
- Full Message Memory capacity (4352 words).

#### 7.12.8.1 Dynamic Characteristics for the CANx TX and RX Pins

PARAMETER		MIN	TYP	MAX	UNIT
$t_d(\text{CANx\_FD\_TX})$	Delay time, transmit shift register to CANx_FD_TX pin <sup>(1)</sup>			15	ns
$t_d(\text{CANx\_FD\_RX})$	Delay time, CANx_FD_RX pin to receive shift register <sup>(1)</sup>			10	ns

(1) These values do not include rise/fall times of the output buffer.

### 7.12.9 Serial Communication Interface (SCI)

The SCI has the following features:

- Standard universal asynchronous receiver-transmitter (UART) communication
- Standard non-return to zero (NRZ) format
- Double-buffered receive and transmit functions
- Asynchronous or iso-synchronous communication modes with no CLK pin
- Capability to use Direct Memory Access (DMA) for transmit and receive data
- Two external pins: RS232\_RX and RS232\_TX

#### 7.12.9.1 SCI Timing Requirements

		MIN	TYP	MAX	UNIT
f(baud)	Supported baud rate at 20 pF		921.6		kHz

### 7.12.10 Inter-Integrated Circuit Interface (I2C)

The inter-integrated circuit (I2C) module is a multi-controller communication module providing an interface between devices compliant with Philips Semiconductor I2C-bus specification version 2.1 and connected by an I<sup>2</sup>C-bus™. This module will support any target or controller I2C compatible device.

The I2C has the following features:

- Compliance to the Philips I2C bus specification, v2.1 (The I2C Specification, Philips document number 9398 393 40011)
  - Bit/Byte format transfer
  - 7-bit and 10-bit device addressing modes
  - General call
  - START byte
  - Multi-controller transmitter/ target receiver mode
  - Multi-controller receiver/ target transmitter mode
  - Combined controller transmit/receive and receive/transmit mode
  - Transfer rates of 100 kbps up to 400 kbps (Phillips fast-mode rate)
- Free data format
- Two DMA events (transmit and receive)
- DMA event enable/disable capability
- Module enable/disable capability
- The SDA and SCL are optionally configurable as general purpose I/O
- Slew rate control of the outputs
- Open drain control of the outputs
- Programmable pullup/pulldown capability on the inputs
- Supports Ignore NACK mode

---

#### Note

This I2C module does not support:

- High-speed (HS) mode
  - C-bus compatibility mode
  - The combined format in 10-bit address mode (the I2C sends the target address second byte every time it sends the target address first byte)
-

**7.12.10.1 I2C Timing Requirements**

(1)		STANDARD MODE		FAST MODE		UNIT
		MIN	MAX	MIN	MAX	
$t_{c(SCL)}$	Cycle time, SCL	10		2.5		$\mu\text{s}$
$t_{su(SCLH-SDAL)}$	Setup time, SCL high before SDA low (for a repeated START condition)	4.7		0.6		$\mu\text{s}$
$t_{h(SCLL-SDAL)}$	Hold time, SCL low after SDA low (for a START and a repeated START condition)	4		0.6		$\mu\text{s}$
$t_{w(SCLL)}$	Pulse duration, SCL low	4.7		1.3		$\mu\text{s}$
$t_{w(SCLH)}$	Pulse duration, SCL high	4		0.6		$\mu\text{s}$
$t_{su(SDA-SCLH)}$	Setup time, SDA valid before SCL high	250		100		$\mu\text{s}$
$t_{h(SCLL-SDA)}$	Hold time, SDA valid after SCL low	0	3.45 <sup>(1)</sup>	0	0.9	$\mu\text{s}$
$t_{w(SDAH)}$	Pulse duration, SDA high between STOP and START conditions	4.7		1.3		$\mu\text{s}$
$t_{su(SCLH-SDAH)}$	Setup time, SCL high before SDA high (for STOP condition)	4		0.6		$\mu\text{s}$
$t_{w(SP)}$	Pulse duration, spike (must be suppressed)			0	50	ns
$C_b$ (2) (3)	Capacitive load for each bus line		400		400	pF

- (1) The I2C pins SDA and SCL do not feature fail-safe I/O buffers. These pins could potentially draw current when the device is powered down.
- (2) The maximum  $t_{h(SDA-SCLL)}$  for I2C bus devices has only to be met if the device does not stretch the low period ( $t_{w(SCLL)}$ ) of the SCL signal.
- (3)  $C_b$  = total capacitance of one bus line in pF. If mixed with fast-mode devices, faster fall-times are allowed.

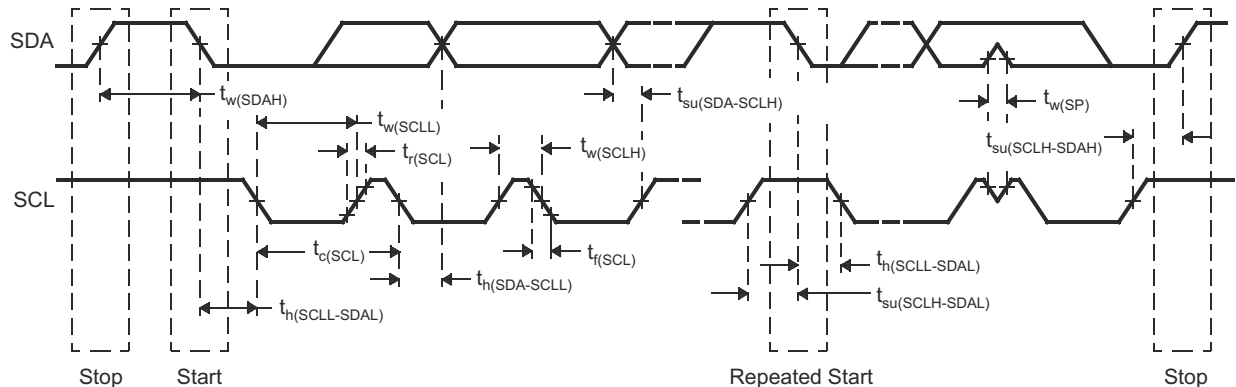

**Figure 7-16. I2C Timing Diagram**

**Note**

- A device must internally provide a hold time of at least 300 ns for the SDA signal (referred to the  $V_{IHmin}$  of the SCL signal) to bridge the undefined region of the falling edge of SCL.
- The maximum  $t_{h(SDA-SCLL)}$  has only to be met if the device does not stretch the LOW period ( $t_{w(SCLL)}$ ) of the SCL signal. E.A Fast-mode I2C-bus device can be used in a Standard-mode I2C-bus system, but the requirement  $t_{su(SDA-SCLH)} \geq 250$  ns must then be met. This will automatically be the case if the device does not stretch the LOW period of the SCL signal. If such a device does stretch the LOW period of the SCL signal, it must output the next data bit to the SDA line  $t_r \max + t_{su(SDA-SCLH)}$ .

### 7.12.11 Quad Serial Peripheral Interface (QSPI)

The quad serial peripheral interface (QSPI) module is a kind of SPI module that allows single, dual, or quad read access to external SPI devices. This module has a memory mapped register interface, which provides a direct interface for accessing data from external SPI devices and thus simplifying software requirements. The QSPI works as a master only. The QSPI in the device is primarily intended for fast booting from quad-SPI flash memories.

The QSPI supports the following features:

- Programmable clock divider
- Six-pin interface
- Programmable length (from 1 to 128 bits) of the words transferred
- Programmable number (from 1 to 4096) of the words transferred
- Support for 3-, 4-, or 6-pin SPI interface
- Optional interrupt generation on word or frame (number of words) completion
- Programmable delay between chip select activation and output data from 0 to 3 QSPI clock cycles

Section 7.12.11.2 and Section 7.12.11.3 assume the operating conditions stated in Section 7.12.11.1.

#### 7.12.11.1 QSPI Timing Conditions

		MIN	TYP	MAX	UNIT
Input Conditions					
$t_R$	Input rise time	1		3	ns
$t_F$	Input fall time	1		3	ns
Output Conditions					
$C_{LOAD}$	Output load capacitance	2		15	pF

#### 7.12.11.2 Timing Requirements for QSPI Input (Read) Timings

Clock Mode 0 (clk polarity = 0 ; clk phase = 0 ) is the mode of operation. <sup>(1)</sup>

		MIN	TYP	MAX	UNIT
$t_{su(D-SCLK)}$	Setup time, d[3:0] valid before falling sclk edge	5			ns
$t_{h(SCLK-D)}$	Hold time, d[3:0] valid after falling sclk edge	1			ns
$t_{su(D-SCLK)}$	Setup time, final d[3:0] bit valid before final falling sclk edge	5 – P <sup>(2)</sup>			ns
$t_{h(SCLK-D)}$	Hold time, final d[3:0] bit valid after final falling sclk edge	1 + P <sup>(2)</sup>			ns

(1) The Device captures data on the falling clock edge in Clock Mode 0, as opposed to the traditional rising clock edge. Although non-standard, the falling-edge-based setup and hold time timings have been designed to be compatible with standard SPI devices that launch data on the falling edge in Clock Mode 0.

(2) P = SCLK period in ns.

**7.12.11.3 QSPI Switching Characteristics**

NO.	PARAMETER		MIN	TYP	MAX	UNIT
Q1	$t_{c(SCLK)}$	Cycle time, sclk	12.5			ns
Q2	$t_{w(SCLKL)}$	Pulse duration, sclk low	$Y * P - 3^{(1)(2)}$			ns
Q3	$t_{w(SCLKH)}$	Pulse duration, sclk high	$Y * P - 3^{(1)}$			ns
Q4	$t_{d(CS-SCLK)}$	Delay time, sclk falling edge to cs active edge	$-M * P - 1^{(1)(3)}$		$-M * P + 2.5^{(1)(3)}$	ns
Q5	$t_{d(SCLK-CS)}$	Delay time, sclk falling edge to cs inactive edge	$N * P - 1^{(1)(3)}$		$N * P + 2.5^{(1)(3)}$	ns
Q6	$t_{d(SCLK-D1)}$	Delay time, sclk falling edge to d[1] transition	-2.5		4	ns
Q7	$t_{ena(CS-D1LZ)}$	Enable time, cs active edge to d[1] driven (lo-z)	$-P - 4^{(3)}$		$-P + 1^{(3)}$	ns
Q8	$t_{dis(CS-D1Z)}$	Disable time, cs active edge to d[1] tri-stated (hi-z)	$-P - 4^{(3)}$		$-P + 1^{(3)}$	ns
Q9	$t_{d(SCLK-D1)}$	Delay time, sclk first falling edge to first d[1] transition (for PHA = 0 only)	$-2.5 - P^{(3)}$		$4 - P^{(3)}$	ns
Q12	$t_{su(D-SCLK)}$	Setup time, d[3:0] valid before falling sclk edge	5			ns
Q13	$t_{h(SCLK-D)}$	Hold time, d[3:0] valid after falling sclk edge	1			ns
Q14	$t_{su(D-SCLK)}$	Setup time, final d[3:0] bit valid before final falling sclk edge	$5 - P^{(3)}$			ns
Q15	$t_{h(SCLK-D)}$	Hold time, final d[3:0] bit valid after final falling sclk edge	$1 + P^{(3)}$			ns

- (1) The Y parameter is defined as follows: If DCLK\_DIV is 0 or ODD then, Y equals 0.5. If DCLK\_DIV is EVEN then, Y equals (DCLK\_DIV/2) / (DCLK\_DIV+1). For best performance, it is recommended to use a DCLK\_DIV of 0 or ODD to minimize the duty cycle distortion. All required details about clock division factor DCLK\_DIV can be found in the device-specific Technical Reference Manual.
- (2) P = SCLK period in ns.
- (3) M = QSPI\_SPI\_DC\_REG.DDx + 1, N = 2

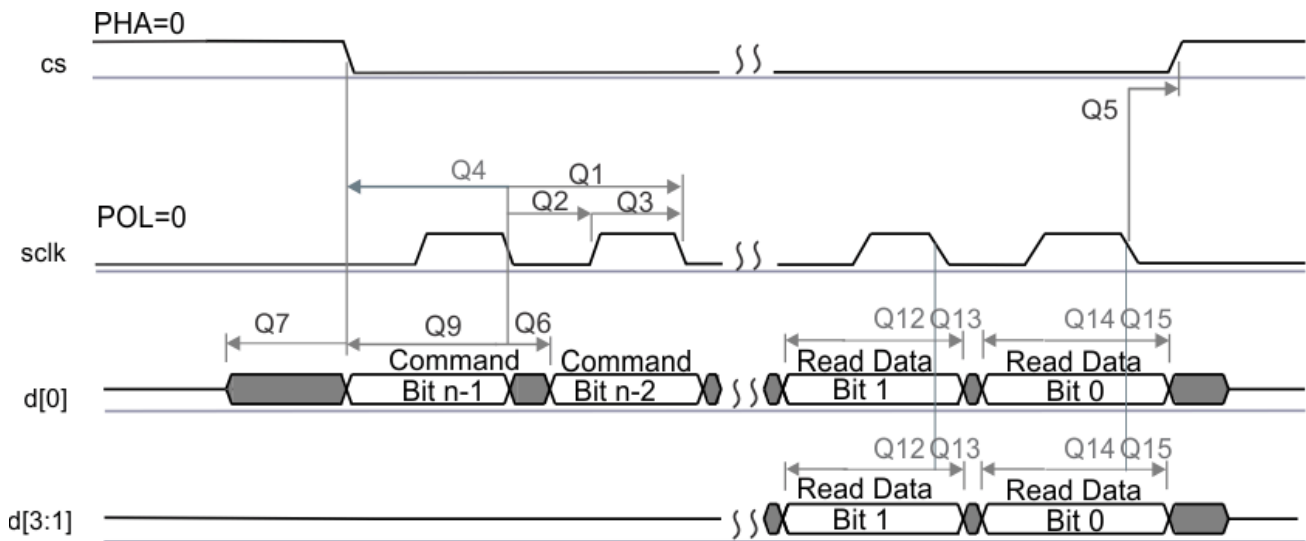

SPRS85v TIMING QSPI1 02

**Figure 7-17. QSPI Read (Clock Mode 0)**

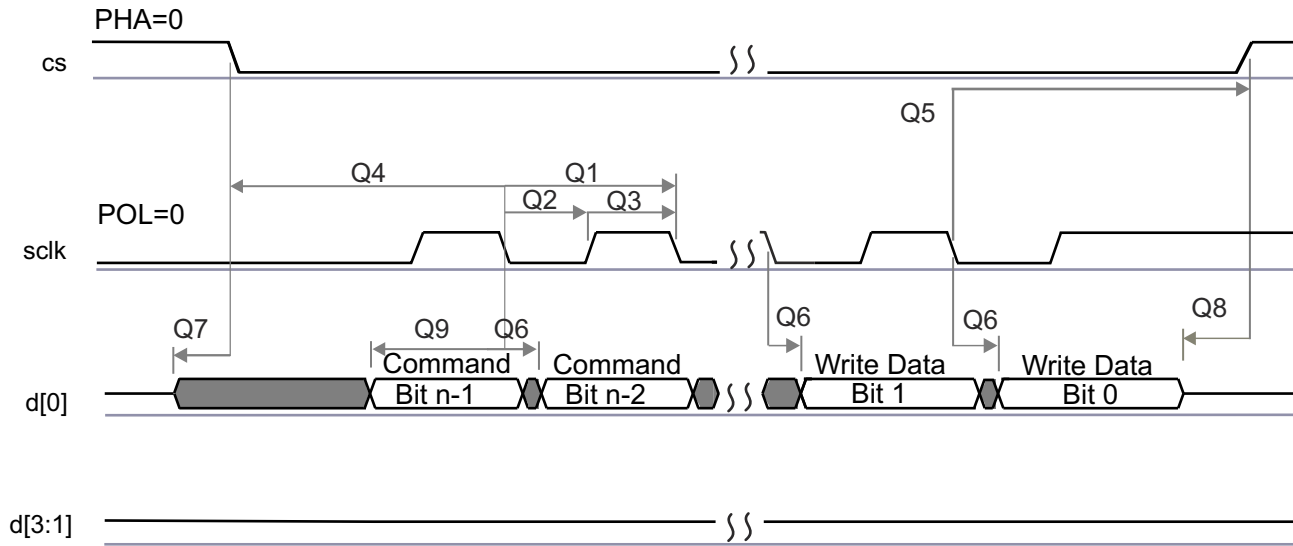

SPRS85v\_TIMING\_OSP11\_04

**Figure 7-18. QSPI Write (Clock Mode 0)**

### 7.12.12 ETM Trace Interface

Section 7.12.12.2 assumes the recommended operating conditions stated in Section 7.12.12.1.

#### 7.12.12.1 ETMTRACE Timing Conditions

		MIN	TYP	MAX	UNIT
Output Conditions					
C <sub>LOAD</sub>	Output load capacitance	2		20	pF

#### 7.12.12.2 ETM TRACE Switching Characteristics

NO.	PARAMETER	MIN	TYP	MAX	UNIT
1	t <sub>cyc(ETM)</sub> Cycle time, TRACECLK period	20			ns
2	t <sub>h(ETM)</sub> Pulse Duration, TRACECLK High	9			ns
3	t <sub>l(ETM)</sub> Pulse Duration, TRACECLK Low	9			ns
4	t <sub>r(ETM)</sub> Clock and data rise time			3.3	ns
5	t <sub>f(ETM)</sub> Clock and data fall time			3.3	ns
6	t <sub>d(ETMTRACE CLKH-ETMDATAV)</sub> Delay time, ETM trace clock high to ETM data valid	1		7	ns
7	t <sub>d(ETMTRACE CLKL-ETMDATAV)</sub> Delay time, ETM trace clock low to ETM data valid	1		7	ns

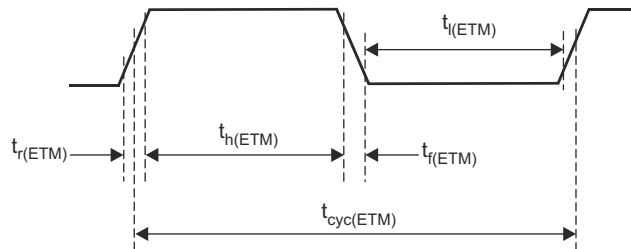

**Figure 7-19. ETMTRACECLKOUT Timing**

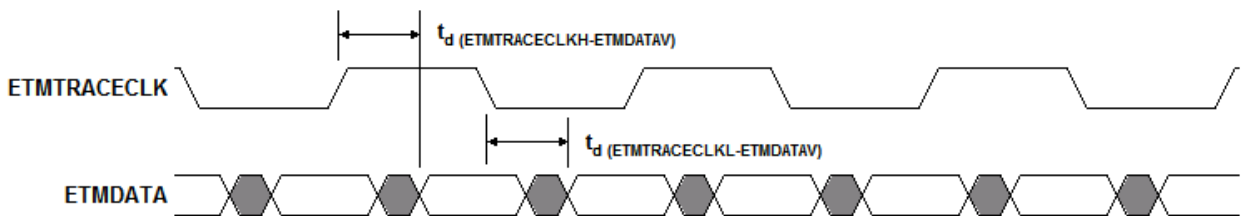

**Figure 7-20. ETMDATA Timing**

### 7.12.13 Data Modification Module (DMM)

A Data Modification Module (DMM) gives the ability to write external data into the device memory.

The DMM has the following features:

- Acts as a bus master, thus enabling direct writes to the 4GB address space without CPU intervention
- Writes to memory locations specified in the received packet (leverages packets defined by trace mode of the RAM trace port [RTP] module)
- Writes received data to consecutive addresses, which are specified by the DMM (leverages packets defined by direct data mode of RTP module)
- Configurable port width (1, 2, 4, 8, 16 pins)
- Up to 100 Mbit/s pin data rate

#### 7.12.13.1 DMM Timing Requirements

		MIN	TYP	MAX	UNIT
$t_{cyc(DMM)}$	Clock period	10			ns
$t_R$	Clock rise time	1		3	ns
$t_F$	Clock fall time	1		3	ns
$t_h(DMM)$	High pulse width	6			ns
$t_l(DMM)$	Low pulse width	6			ns
$t_{ssu(DMM)}$	SYNC active to clk falling edge setup time	2			ns
$t_{sh(DMM)}$	DMM clk falling edge to SYNC deactive hold time	3			ns
$t_{dsu(DMM)}$	DATA to DMM clk falling edge setup time	2			ns
$t_{dh(DMM)}$	DMM clk falling edge to DATA hold time	3			ns

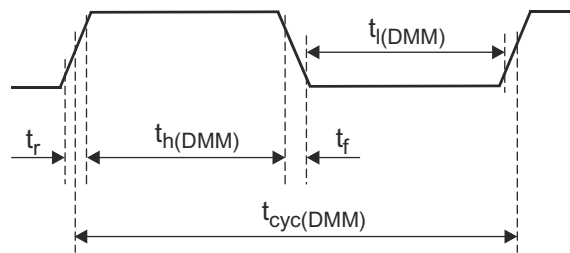

Figure 7-21. DMMCLK Timing

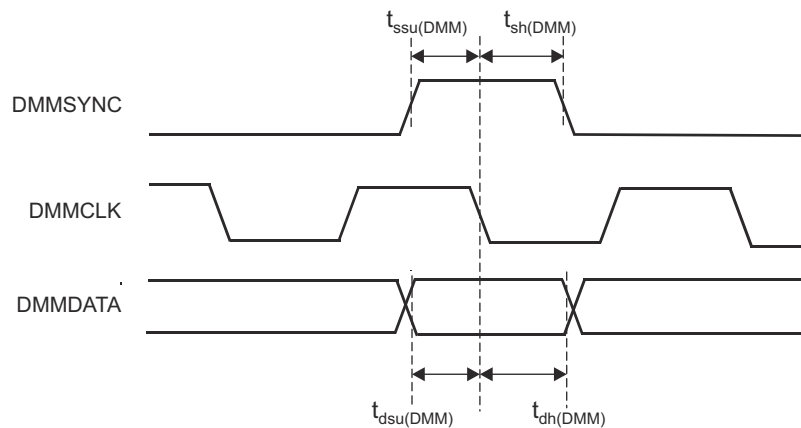

Figure 7-22. DMMDATA Timing

### 7.12.14 JTAG Interface

Section 7.12.14.2 and Section 7.12.14.3 assume the operating conditions stated in Section 7.12.14.1.

#### 7.12.14.1 JTAG Timing Conditions

		MIN	TYP	MAX	UNIT
Input Conditions					
$t_R$	Input rise time	1		3	ns
$t_F$	Input fall time	1		3	ns
Output Conditions					
$C_{LOAD}$	Output load capacitance	2		15	pF

#### 7.12.14.2 Timing Requirements for IEEE 1149.1 JTAG

NO.	PARAMETER		MIN	TYP	MAX	UNIT
1	$t_c(TCK)$	Cycle time TCK	66.66			ns
1a	$t_w(TCKH)$	Pulse duration TCK high (40% of $t_c$ )	26.67			ns
1b	$t_w(TCKL)$	Pulse duration TCK low(40% of $t_c$ )	26.67			ns
3	$t_{su}(TDI-TCK)$	Input setup time TDI valid to TCK high	2.5			ns
	$t_{su}(TMS-TCK)$	Input setup time TMS valid to TCK high	2.5			ns
4	$t_h(TCK-TDI)$	Input hold time TDI valid from TCK high	18			ns
	$t_h(TCK-TMS)$	Input hold time TMS valid from TCK high	18			ns

#### 7.12.14.3 Switching Characteristics Over Recommended Operating Conditions for IEEE 1149.1 JTAG

NO.	PARAMETER		MIN	TYP	MAX	UNIT
2	$t_d(TCKL-TDOV)$	Delay time, TCK low to TDO valid	0		25	ns

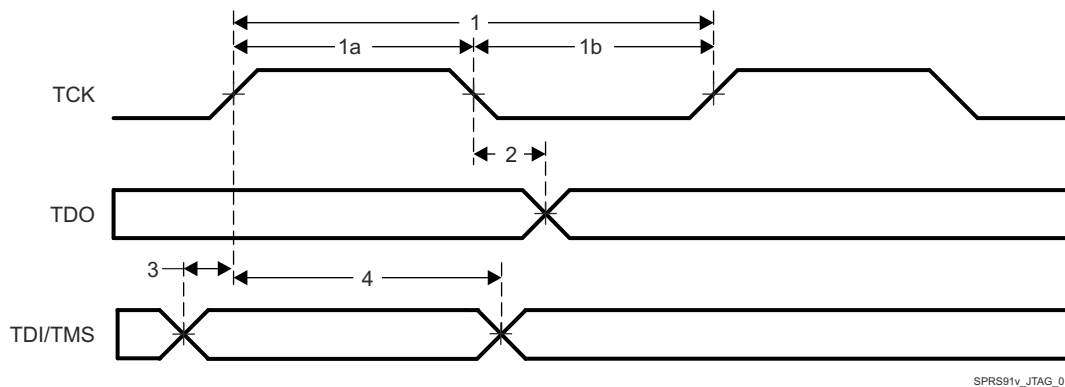

SPRS91v\_JTAG\_01

Figure 7-23. JTAG Timing

## 8 Detailed Description

### 8.1 Overview

The AWR6843AOP device includes the entire Millimeter Wave blocks and analog baseband signal chain for three transmitters and four receivers, as well as a customer-programmable MCU and DSP. This device is applicable as a radar-on-a-chip in use cases with modest requirements for memory, processing capacity, and application code size. These could be cost-sensitive automotive applications that are evolving from 24-GHz narrowband implementation and some emerging simple ultra-short-range radar applications. Typical application examples for this device include:

- Child presence detection
- Occupant detection
- Seat belt reminder
- Gesture detection
- Driver vital sign monitoring

In terms of scalability, the AWR6843AOP device could be paired with a low-end external MCU, to address more complex applications that might require additional memory for larger application software footprint and faster interfaces. Because the AWR6843AOP device also provides high speed data interfaces like Serial-LVDS, it is suitable for interfacing with more capable external processing blocks. Here system designers can choose the AWR6843AOP to provide raw ADC data.

### 8.2 Functional Block Diagram

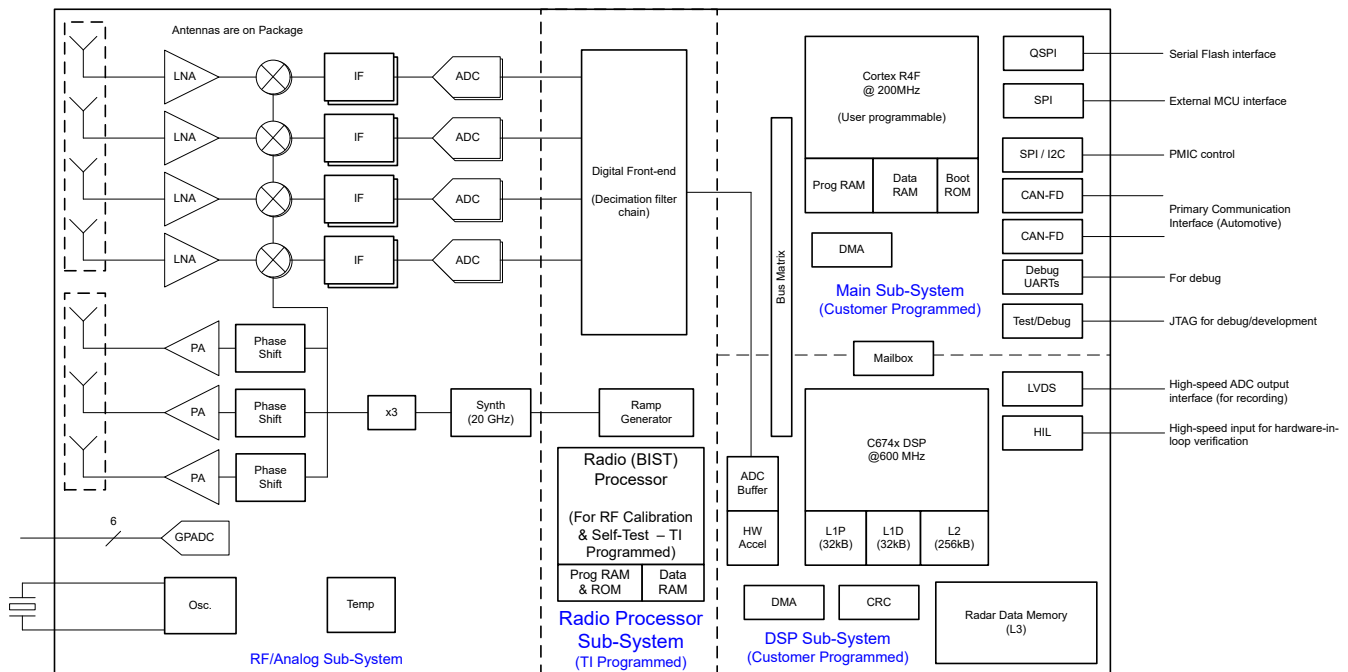

Figure 8-1. Functional Block Diagram

## 8.3 Subsystems

### 8.3.1 RF and Analog Subsystem

The RF and analog subsystem includes the RF and analog circuitry – namely, the synthesizer, PA, LNA, mixer, IF, and ADC. This subsystem also includes the crystal oscillator and temperature sensors. The three transmit channels can be operated up to a maximum of two at a time (simultaneously) in 1.3-V mode. The three Transmit channels simultaneous operation is supported only with 1-V LDO bypass and PA LDO disabled mode for transmit beamforming purpose, as required. In this mode, the 1-V supply needs to be fed on the VIN\_13RF1, VIN\_13RF2, and VOUT PA pin; whereas, the four receive channels can all be operated simultaneously.

### 8.3.1.1 Clock Subsystem

The AWR6843AOP clock subsystem generates 60 to 64 GHz from an input reference of 40-MHz crystal. It has a built-in oscillator circuit followed by a clean-up PLL and a RF synthesizer circuit. The output of the RF synthesizer is then processed by an X3 multiplier to create the required frequency in the 60 to 64 GHz spectrum. The RF synthesizer output is modulated by the timing engine block to create the required waveforms for effective sensor operation.

The clean-up PLL also provides a reference clock for the host processor after system wakeup.

The clock subsystem also has built-in mechanisms for detecting the presence of a crystal and monitoring the quality of the generated clock.

Figure 8-2 describes the clock subsystem.

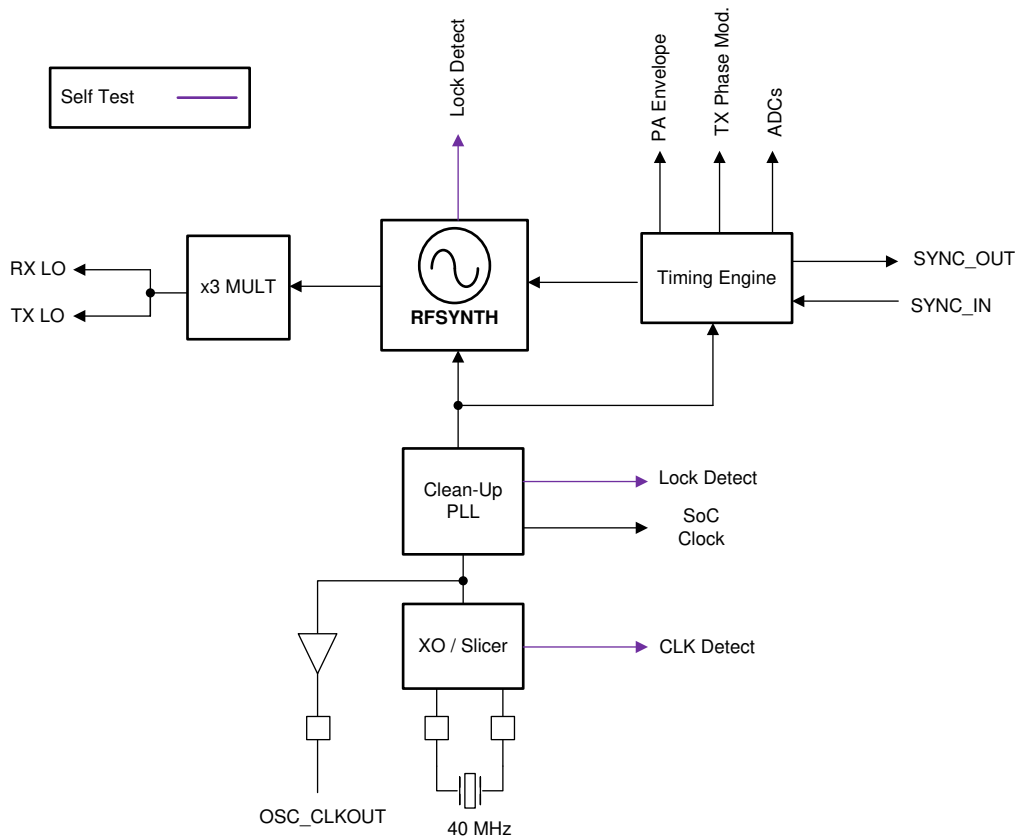

**Figure 8-2. Clock Subsystem**

### 8.3.1.2 Transmit Subsystem

The AWR6843AOP transmit subsystem consists of three parallel transmit chains, each with independent phase and amplitude control. The device supports 6-bit linear phase modulation for MIMO radar and interference mitigation.

The transmit chains also support programmable backoff for system optimization.

Figure 8-3 describes the transmit subsystem.

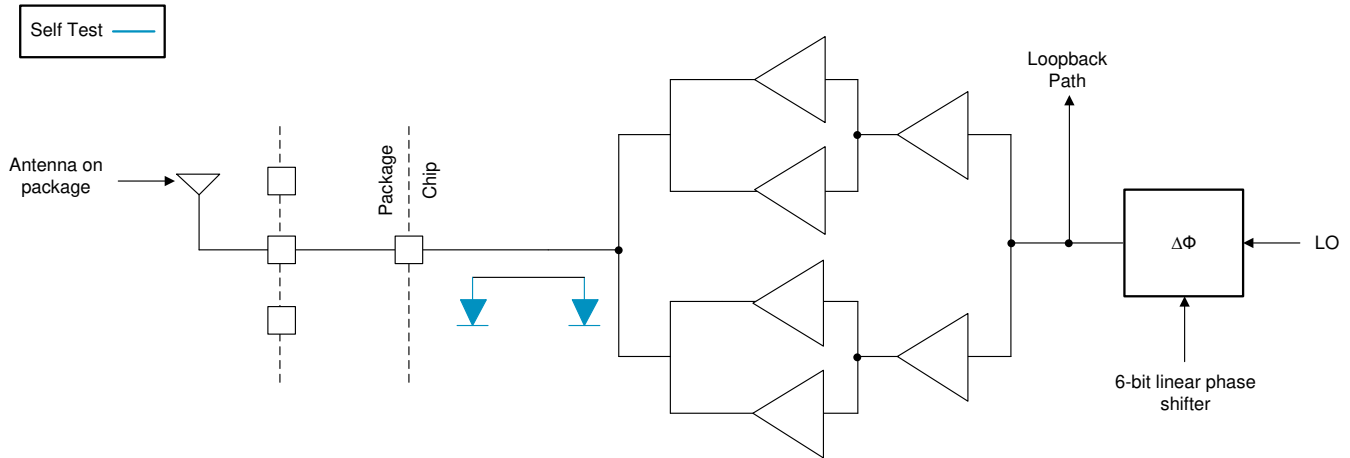

Figure 8-3. Transmit Subsystem (Per Channel)

### 8.3.1.3 Receive Subsystem

The AWR6843AOP receive subsystem consists of four parallel channels. A single receive channel consists of an LNA, mixer, IF filtering, ADC conversion, and decimation. All four receive channels can be operational at the same time an individual power-down option is also available for system optimization.

Unlike conventional real-only receivers, the AWR6843AOP device supports a complex baseband architecture, which uses quadrature mixer and dual IF and ADC chains to provide complex I and Q outputs for each receiver channel. The AWR6843AOP is targeted for fast chirp systems. The band-pass IF chain has configurable lower cutoff frequencies above 175 kHz and can support bandwidths up to 10 MHz.

Figure 8-4 describes the receive subsystem.

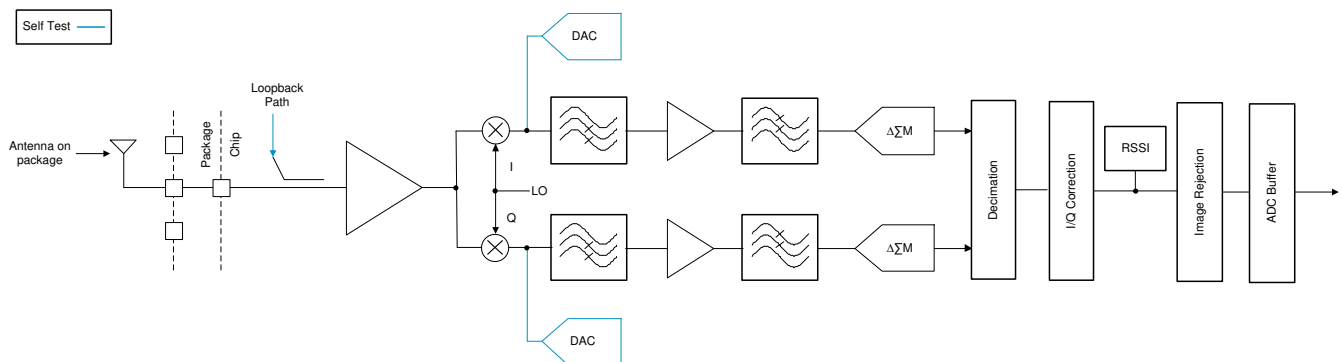
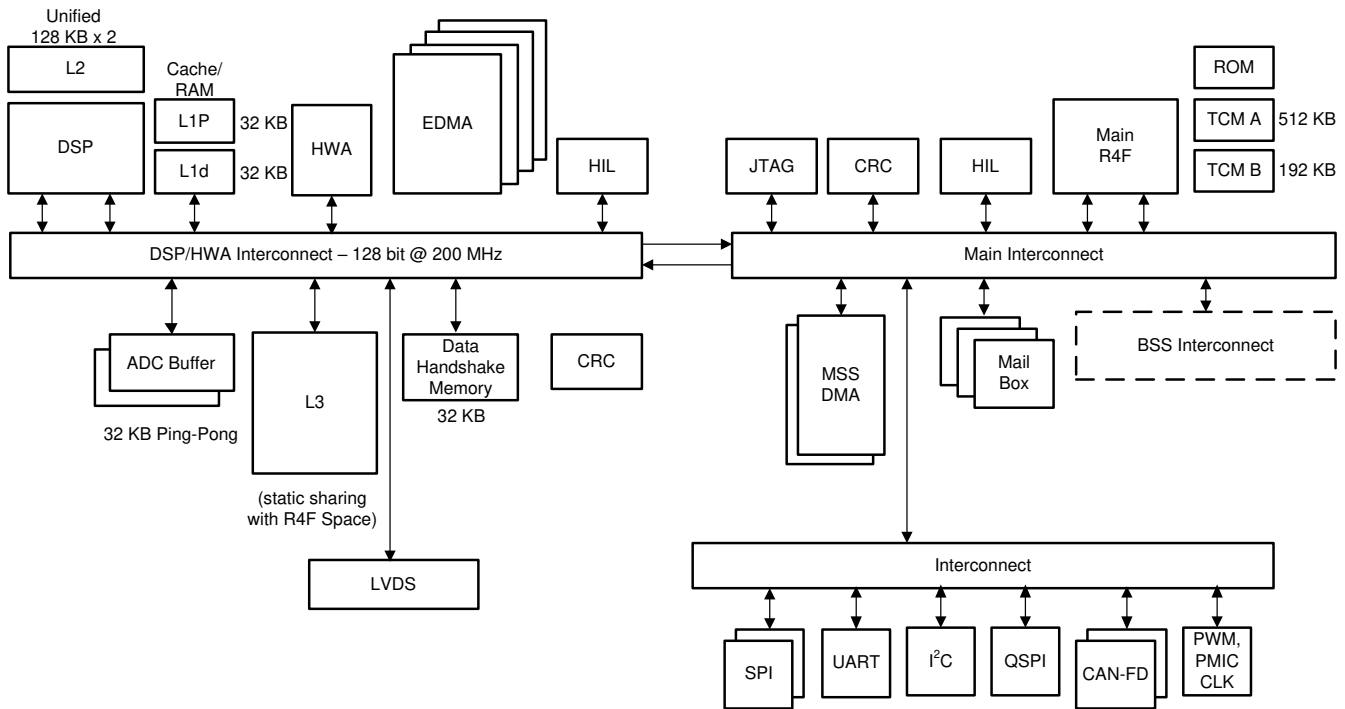

Figure 8-4. Receive Subsystem (Per Channel)

### 8.3.2 Processor Subsystem



**Figure 8-5. Processor Subsystem**

Figure 8-5 shows the block diagram for customer programmable processor subsystems in the AWR6843AOP device. At a high level there are two customer programmable subsystems, as shown separated by a dotted line in the diagram. Left hand side shows the DSP Subsystem which contains TI's high-performance C674x DSP, hardware accelerator, a high-bandwidth interconnect for high performance (128-bit, 200MHz), and associated peripherals – four DMAs for data transfer,

LVDS interface for Measurement data output, L3 Radar data cube memory, ADC buffers, CRC engine, and data handshake memory (additional memory provided on interconnect).

The C674x DSP and L1/L2 RAM portion of the DSP subsystem is not supported on the AWR6443 device and therefore, the available memory is 1.4MB compared to 1.75MB on the IWR6843 device. For more information on the features supported and not supported on each device, see the [Device Features Comparison](#) table.

The right side of the diagram shows the main subsystem. Main subsystem as the name suggests is the centre of the device and controls all the device peripherals and house-keeping activities of the device. Main subsystem contains Cortex-R4F (Main R4F) processor and associated peripherals and house-keeping components such as DMAs, CRC and Peripherals (I<sup>2</sup>C, UART, SPIs, CAN-FD, PMIC clocking module, PWM, and others) connected to Main Interconnect through Peripheral Central Resource (PCR interconnect).

Details of the DSP CPU core can be found at <http://www.ti.com/product/TMS320C6748>.

HIL module is shown in both the subsystems and can be used to perform the radar operations feeding the captured data from outside into the device without involving the RF subsystem. HIL on main SS is for controlling the configuration and HIL on DSPSS for high speed ADC data input to the device. Both HIL modules uses the same IOs on the device, one additional IO (DMM\_MUX\_IN) allows selecting either of the two.

### 8.3.3 Automotive Interface

The AWR6843AOP communicates with the automotive network over the following main interfaces:

- 2 CAN-FD modules

### 8.3.4 Host Interface

The host interface can be provided through a SPI, UART, or CAN-FD interface. In some cases the serial interface for industrial applications is transcoded to a different serial standard.

This device communicates with the host radar processor over the following main interfaces:

- Reference Clock – Reference clock available for host processor after device wakeup
- Control – 4-port standard SPI (slave) for host control . All radio control commands (and response) flow through this interface.
- Reset – Active-low reset for device wakeup from host
- Host Interrupt - an indication that the mmwave sensor needs host interface
- Error – Used for notifying the host in case the radio controller detects a fault

### 8.3.5 Main Subsystem Cortex-R4F

The main system includes an ARM Cortex R4F processor, clock with a maximum operating frequency of 200 MHz. User applications executing on this processor control the overall operation of the device, including radar control through well-defined API messages, radar signal processing (assisted by the radar hardware accelerator), and peripherals for external interfaces.

See the [Technical Reference Manual](#) for a complete description and memory map.

### 8.3.6 DSP Subsystem

The DSP subsystem includes TI's standard TMS320C674x megamodule and several blocks of internal memory (L1P, L1D, and L2). For complete information including memory map, please refer to [Technical Reference Manual](#).

### 8.3.7 Hardware Accelerator

The Radar Hardware Accelerator (HWA) is an IP that enables off-loading the burden of certain frequently used computations in FMCW radar signal processing from the main processor. FMCW radar signal processing involves the use of FFT and Log-Magnitude computations to obtain a radar image across the range, velocity, and angle dimensions. Some of the frequently used functions in FMCW radar signal processing can be done within the radar hardware accelerator, while still retaining the flexibility of implementing other proprietary algorithms in the main processor. See the [Radar Hardware Accelerator User's Guide](#) for a functional description and features of this module and see the [Technical Reference Manual](#) for a complete list of register and memory map.

## 8.4 Other Subsystems

### 8.4.1 ADC Channels (Service) for User Application

The AWR6843AOP device includes provision for an ADC service for user application, where the

GPADC engine present inside the device can be used to measure up to six external voltages. The ADC1, ADC2, ADC3, ADC4, ADC5, and ADC6 pins are used for this purpose.

- ADC itself is controlled by TI firmware running inside the BIST subsystem and access to it for customer's external voltage monitoring purpose is via 'monitoring API' calls routed to the BIST subsystem. This API could be linked with the user application running on the MSS R4F.
- BIST subsystem firmware will internally schedule these measurements along with other RF and Analog monitoring operations. The API allows configuring the settling time (number of ADC samples to skip) and number of consecutive samples to take. At the end of a frame, the minimum, maximum and average of the readings will be reported for each of the monitored voltages.

GPADC Specifications:

- 625 Ksps SAR ADC
- 0 to 1.8V input range
- 10-bit resolution

- For 5 out of the 6 inputs, an optional internal buffer (0.4-1.4V input range) is available. Without the buffer, the ADC has a switched capacitor input load modeled with 5pF of sampling capacitance and 12pF parasitic capacitance (GPADC channel 6, the internal buffer is not available).

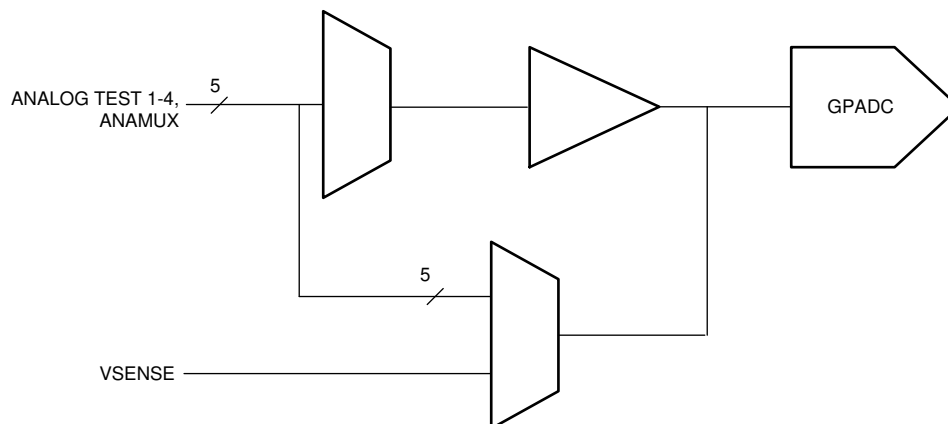

A. GPADC structures are used for measuring the output of internal temperature sensors. The accuracy of these measurements is  $\pm 7^\circ\text{C}$ .

**Figure 8-6. ADC Path**

#### 8.4.1.1 GP-ADC Parameter

PARAMETER	TYP	UNIT
ADC supply	1.8	V
ADC unbuffered input voltage range	0 – 1.8	V
ADC buffered input voltage range <sup>(1)</sup>	0.4 – 1.3	V
ADC resolution	10	bits
ADC offset error	$\pm 5$	LSB
ADC gain error	$\pm 5$	LSB
ADC DNL	-1/+2.5	LSB
ADC INL	$\pm 2.5$	LSB
ADC sample rate <sup>(2)</sup>	625	Ksps
ADC sampling time <sup>(2)</sup>	400	ns
ADC internal cap	10	pF
ADC buffer input capacitance	2	pF
ADC input leakage current	3	uA

(1) Outside of given range, the buffer output will become nonlinear.

(2) ADC itself is controlled by TI firmware running inside the BIST subsystem. For more details please refer to the API calls.

## 8.5 Boot Modes

As soon as device reset is de-asserted, the R4F processor of the Master (Control) system starts executing its bootloader from an on-chip ROM memory.

The bootloader of the Master system operates in two basic modes and these are specified on the user hardware (Printed Circuit Board) by configuring what are termed as “Sense on Power” (SOP) pins. These pins on the device boundary are scanned by the bootloader firmware and choice of mode for bootloader operation is made.

[Table 8-1](#) enumerates the relevant SOP combinations and how these map to bootloader operation.

**Table 8-1. SOP Combinations**

SOP2	SOP1	SOP0	BOOTLOADER MODE AND OPERATION
0	0	1	Functional Mode Device Bootloader loads user application from QSPI Serial Flash to internal RAM and switches the control to it
1	0	1	Flashing Mode Device Bootloader spins in loop to allow flashing of user application (or device firmware patch – Supplied by TI) to the serial flash
0	1	1	Debug Mode Bootloader is bypassed and R4F processor is halted. This allows user to connect emulator at a known point

### 8.5.1 Flashing Mode

In Flashing Mode, the Master System’s bootloader enables the UART driver and expects a data stream comprising of User Application (Binary Image) and Device Firmware (referred to as Device Firmware Patch or Service Pack) from an external flashing utility. [Figure 8-7](#) shows the flashing utility executing on a PC platform, but the protocol can be accomplished on an embedded platform as well.

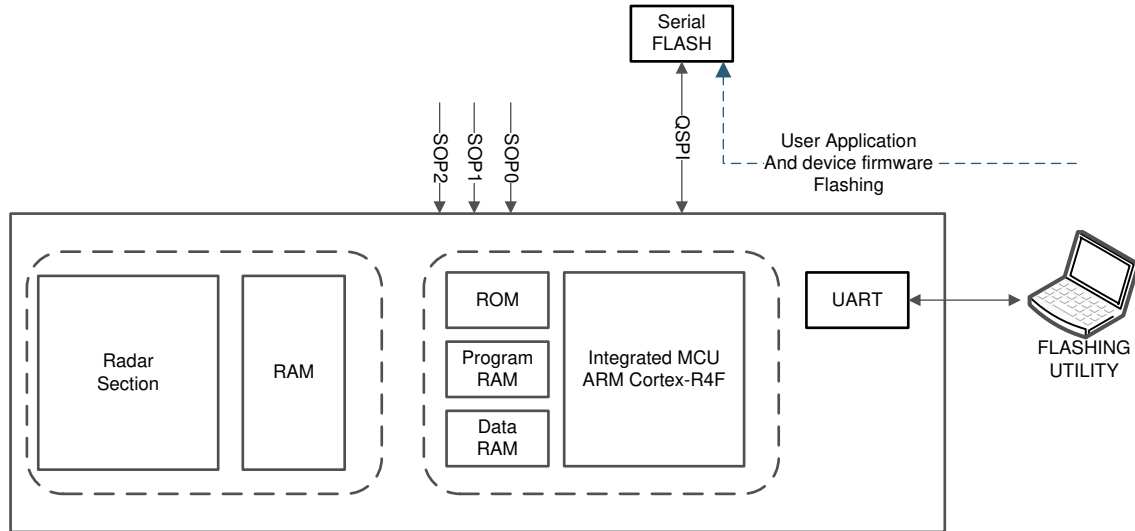
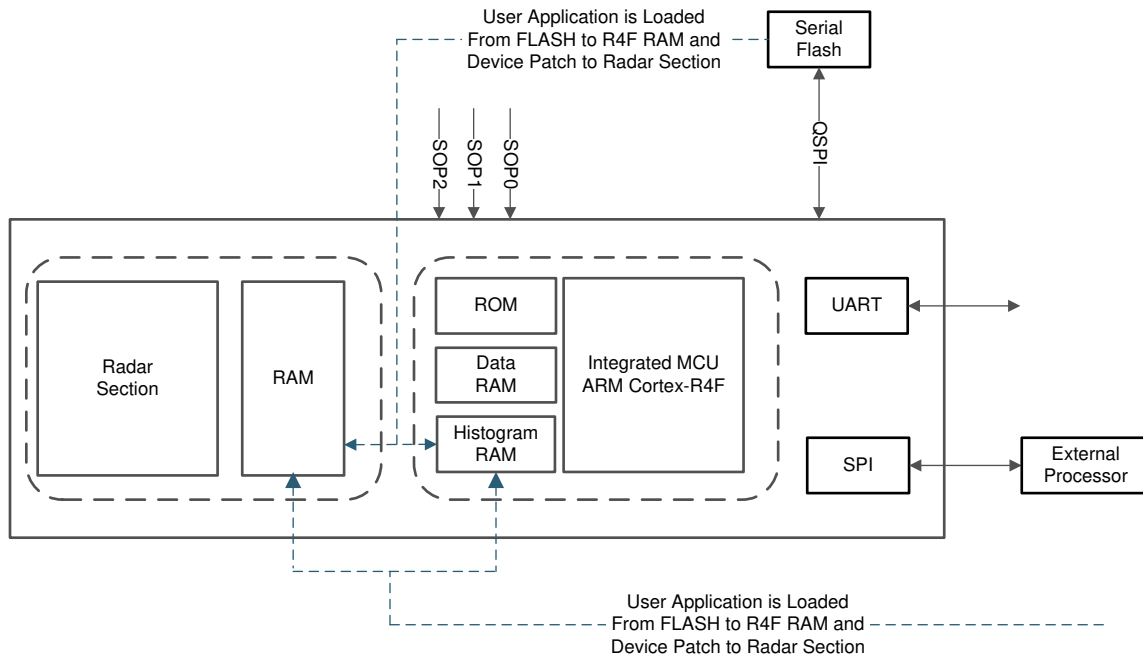

**Figure 8-7. Figure 5. Bootloader Flashing Mode**

### 8.5.2 Functional Mode

In Functional Mode, the Master System's bootloader looks for a valid image in the serial flash memory, interfaced over the QSPI port. If a valid image is found, the bootloader transfers the same to Master System's memory subsystem.

If a valid image (or the QSPI Serial Flash is not found), the bootloader initializes the SPI port and awaits for the image transfer. This operation comes handy for configurations where the AWR6843AOP is interfaced to an external processor which has its own nonvolatile storage hence can store the user application and the AWR6843AOP device's firmware image.



**Figure 8-8. Bootloader's Functional Mode**

## 9 Monitoring and Diagnostics

### 9.1 Monitoring and Diagnostic Mechanisms

Table 9-1 is a list of the main monitoring and diagnostic mechanisms available in the Functional Safety-Compliant devices

**Table 9-1. Monitoring and Diagnostic Mechanisms for Functional Safety-Compliant Devices**

NO	FEATURE	DESCRIPTION
1	Boot time LBIST For MSS R4F Core and associated VIM	Device architecture supports hardware logic BIST (LBIST) engine self-test Controller (STC). This logic is used to provide a very high diagnostic coverage (>90%) on the MSS R4F CPU core and Vectored Interrupt Module (VIM) at a transistor level. LBIST for the CPU and VIM need to be triggered by application code before starting the functional safety application. CPU stays there in while loop and does not proceed further if a fault is identified.
2	Boot time PBIST for MSS R4F TCM Memories	Main R4F has three Tightly coupled Memories (TCM) memories TCMA, TCMB0 and TCMB1. Device architecture supports a hardware programmable memory BIST (PBIST) engine. This logic is used to provide a very high diagnostic coverage (March-13n) on the implemented MSS R4F TCMs at a transistor level. PBIST for TCM memories is triggered by Bootloader at the boot time before starting download of application from Flash or peripheral interface. CPU stays there in while loop and does not proceed further if a fault is identified.
3	End to End ECC for MSS R4F TCM Memories	TCMs diagnostic is supported by Single error correction double error detection (SECDED) ECC diagnostic. An 8-bit code word is used to store the ECC data as calculated over the 64-bit data bus. ECC evaluation is done by the ECC control logic inside the CPU. This scheme provides end-to-end diagnostics on the transmissions between CPU and TCM. CPU can be configured to have predetermined response (Ignore or Abort generation) to single and double bit error conditions.
4	Main R4F TCM bit multiplexing	Logical TCM word and its associated ECC code is split and stored in two physical SRAM banks. This scheme provides an inherent diagnostic mechanism for address decode failures in the physical SRAM banks. Faults in the bank addressing are detected by the CPU as an ECC fault. Further, bit multiplexing scheme implemented such that the bits accessed to generate a logical (CPU) word are not physically adjacent. This scheme helps to reduce the probability of physical multi-bit faults resulting in logical multi-bit faults; rather they manifest as multiple single bit faults. As the SECDED TCM ECC can correct a single bit fault in a logical word, this scheme improves the usefulness of the TCM ECC diagnostic. Both these features are hardware features and cannot be enabled or disabled by application software.
5	Clock Monitor	Device architecture supports Three Digital Clock Comparators (DCCs) and an internal RCOSC. Dual functionality is provided by these modules – Clock detection and Clock Monitoring. DCCint is used to check the availability/range of Reference clock at boot otherwise the device is moved into limp mode (Device still boots but on 10MHz RCOSC clock source. This provides debug capability). DCCint is only used by boot loader during boot time. It is disabled once the APLL is enabled and locked. DCC1 is dedicated for APLL lock detection monitoring, comparing the APLL output divided version with the Reference input clock of the device. Initially (before configuring APLL), DCC1 is used by bootloader to identify the precise frequency of reference input clock against the internal RCOSC clock source. Failure detection for DCC1 would cause the device to go into limp mode. DCC2 module is one which is available for user software. From the list of clock options given in detailed spec, any two clocks can be compared. One example usage is to compare the CPU clock with the Reference or internal RCOSC clock source. Failure detection is indicated to the MSS R4F CPU via Error Signaling Module (ESM).
7	RTI/WD for MSS R4F	Device architecture supports the use of an internal watchdog that is implemented in the real-time interrupt (RTI) module. The internal watchdog has two modes of operation: digital watchdog (DWD) and digital windowed watchdog (DWWD). The modes of operation are mutually exclusive; the designer can elect to use one mode or the other but not both at the same time. Watchdog can issue either an internal (warm) system reset or a CPU non-mask able interrupt upon detection of a failure. The Watchdog is enabled by the bootloader in DWD mode at boot time to track the boot process. Once the application code takes up the control, Watchdog can be configured again for mode and timings based on specific customer requirements.

**Table 9-1. Monitoring and Diagnostic Mechanisms for Functional Safety-Compliant Devices (continued)**

NO	FEATURE	DESCRIPTION
8	MPU for MSS R4F	Cortex-R4F CPU includes an MPU. The MPU logic can be used to provide spatial separation of software tasks in the device memory. Cortex-R4F MPU supports 12 regions. It is expected that the operating system controls the MPU and changes the MPU settings based on the needs of each task. A violation of a configured memory protection policy results in a CPU abort.
9	PBIST for Peripheral interface SRAMs - SPIs, CAN-FDs	Device architecture supports a hardware programmable memory BIST (PBIST) engine for Peripheral SRAMs as well. PBIST for peripheral SRAM memories can be triggered by the application. User can elect to run the PBIST on one SRAM or on groups of SRAMs based on the execution time, which can be allocated to the PBIST diagnostic. The PBIST tests are destructive to memory contents, and as such are typically run only at boot time. However, the user has the freedom to initiate the tests at any time if peripheral communication can be hindered. Any fault detected by the PBIST results in an error indicated in PBIST status registers.
10	ECC for Peripheral interface SRAMs – SPIs, CAN-FDs	Peripheral interface SRAMs diagnostic is supported by Single error correction double error detection (SECDED) ECC diagnostic. When a single or double bit error is detected the MSS R4F is notified via ESM (Error Signaling Module). This feature is disabled after reset. Software must configure and enable this feature in the peripheral and ESM module. ECC failure (both single bit corrected and double bit uncorrectable error conditions) is reported to the MSS R4F as an interrupt via ESM module.
11	Configuration registers protection for Main SS peripherals	All the Main SS peripherals (SPIs, CAN-FDs, I2C, DMAs, RTI/WD, DCCs, IOMUX etc.) are connected to interconnect via Peripheral Central resource (PCR). This provides two diagnostic mechanisms that can limit access to peripherals. Peripherals can be clock gated per peripheral chip select in the PCR. This can be utilized to disable unused features such that they cannot interfere. In addition, each peripheral chip select can be programmed to limit access based on privilege level of transaction. This feature can be used to limit access to entire peripherals to privileged operating system code only. These diagnostic mechanisms are disabled after reset. Software must configure and enable these mechanisms. Protection violation also generates an 'error' that result in abort to MSS R4F or error response to other peripherals such as DMAs.
12	Cyclic Redundancy Check – Main SS	Device architecture supports hardware CRC engine on Main SS implementing the below polynomials. <ul style="list-style-type: none"> <li>• CRC16 CCITT – 0x10</li> <li>• CRC32 Ethernet – 0x04C11DB7</li> <li>• CRC64</li> <li>• CRC 32C – CASTAGNOLI – 0x1EDC6F4</li> <li>• CRC32P4 – E2E Profile4 – 0xF4ACFB1</li> <li>• CRC-8 – H2F Autosar – 0x2F</li> <li>• CRC-8 – VDA CAN-FD – 0x1D</li> </ul> The read operation of the SRAM contents to the CRC can be done by CPU or by DMA. The comparison of results, indication of fault, and fault response are the responsibility of the software managing the test.
13	MPU for DMAs	Device architecture supports MPUs on Main SS DMAs. Failure detection by MPU is reported to the MSS R4F CPU core as an interrupt via ESM. DSPSS's high performance EDMAs also includes MPUs on both read and writes master ports. EDMA MPUs supports 8 regions. Failure detection by MPU is reported to the DSP core as an interrupt via local ESM.
14	Boot time LBIST For BIST R4F Core and associated VIM	Device architecture supports hardware logic BIST (LBIST) even for BIST R4F core and associated VIM module. This logic provides very high diagnostic coverage (>90%) on the BIST R4F CPU core and VIM. This is triggered by MSS R4F boot loader at boot time and it does not proceed further if the fault is detected.
15	Boot time PBIST for BIST R4F TCM Memories	Device architecture supports a hardware programmable memory BIST (PBIST) engine for BIST R4F TCMs which provide a very high diagnostic coverage (March-13n) on the BIST R4F TCMs. PBIST is triggered by MSS R4F Bootloader at the boot time and it does not proceed further if the fault is detected.

**Table 9-1. Monitoring and Diagnostic Mechanisms for Functional Safety-Compliant Devices (continued)**

NO	FEATURE	DESCRIPTION
16	End to End ECC for BIST R4F TCM Memories	BIST R4F TCMs diagnostic is supported by Single error correction double error detection (SECDED) ECC diagnostic. Single bit error is communicated to the BIST R4FCPU while double bit error is communicated to MSS R4F as an interrupt so that application code becomes aware of this and takes appropriate action.
17	BIST R4F TCM bit multiplexing	Logical TCM word and its associated ECC code is split and stored in two physical SRAM banks. This scheme provides an inherent diagnostic mechanism for address decode failures in the physical SRAM banks and helps to reduce the probability of physical multi-bit faults resulting in logical multi-bit faults.
18	RTI/WD for BIST R4F	Device architecture supports an internal watchdog for BIST R4F. Timeout condition is reported via an interrupt to MSS R4F and rest is left to application code to either go for SW reset for BIST SS or warm reset for the device to come out of faulty condition.
19	Boot time PBIST for L1P, L1D, L2 and L3 Memories	Device architecture supports a hardware programmable memory BIST (PBIST) engine for DSPSS's L1P, L1D, L2 and L3 memories which provide a very high diagnostic coverage (March-13n). PBIST is triggered by MSS R4F Bootloader at the boot time and it does not proceed further if the fault is detected.
20	Parity on L1P	Device architecture supports Parity diagnostic on DSP's L1P memory. Parity error is reported to the CPU as an interrupt. Note:- L1D memory is not covered by parity or ECC and need to be covered by application level diagnostics.
21	ECC on DSP's L2 Memory	Device architecture supports both Parity Single error correction double error detection (SECDED) ECC diagnostic on DSP's L2 memory. L2 Memory is a unified 256KB of memory used to store program and Data sections for the DSP. A 12-bit code word is used to store the ECC data as calculated over the 256-bit data bus (logical instruction fetch size). The ECC logic for the L2 access is located in the DSP and evaluation is done by the ECC control logic inside the DSP. This scheme provides end-to-end diagnostics on the transmissions between DSP and L2. Byte aligned Parity mechanism is also available on L2 to take care of data section.
22	ECC on Radar Data Cube (L3) Memory	L3 memory is used as Radar data section in Device. Device architecture supports Single error correction double error detection (SECDED) ECC diagnostic on L3 memory. An 8-bit code word is used to store the ECC data as calculated over the 64-bit data bus. Failure detection by ECC logic is reported to the MSS R4F CPU core as an interrupt via ESM.
23	RTI/WD for DSP Core	Device architecture supports the use of an internal watchdog for BIST R4F that is implemented in the real-time interrupt (RTI) module – replication of same module as used in Main SS. This module supports same features as that of RTI/WD for Main/BIST R4F. This watchdog is enabled by customer application code and Timeout condition is reported via an interrupt to MSS R4F and rest is left to application code in MSS R4F to either go for SW reset for DSP SS or warm reset for the device to come out of faulty condition.
24	CRC for DSP Sub-System	Device architecture supports dedicated hardware CRC on DSPSS implementing the below polynomials. <ul style="list-style-type: none"> <li>• CRC16 CCITT - 0x10</li> <li>• CRC32 Ethernet - 0x04C11DB7</li> <li>• CRC64</li> </ul> The read of SRAM contents to the CRC can be done by DSP CPU or by DMA. The comparison of results, indication of fault, and fault response are the responsibility of the software managing the test.
25	MPU for DSP	Device architecture supports MPUs for DSP memory accesses (L1D, L1P, and L2). L2 memory supports 64 regions and 16 regions for L1P and L1D each. Failure detection by MPU is reported to the DSP core as an abort.
26	Temperature Sensors	Device architecture supports various temperature sensors all across the device (next to power hungry modules such as PAs, DSP etc) which is monitored during the inter-frame period. <sup>(1)</sup>
27	Tx Power Monitors	Device architecture supports power detectors at the Tx output. <sup>(2)</sup>

**Table 9-1. Monitoring and Diagnostic Mechanisms for Functional Safety-Compliant Devices (continued)**

NO	FEATURE	DESCRIPTION
28	Error Signaling Error Output	When a diagnostic detects a fault, the error must be indicated. The device architecture provides aggregation of fault indication from internal monitoring/diagnostic mechanisms using a peripheral logic known as the Error Signaling Module (ESM). The ESM provides mechanisms to classify errors by severity and to provide programmable error response. ESM module is configured by customer application code and specific error signals can be enabled or masked to generate an interrupt (Low/High priority) for the MSS R4F CPU. Device supports Nerror output signal (IO) which can be monitored externally to identify any kind of high severity faults in the design which could not be handled by the R4F.
29	Synthesizer (Chirp) frequency monitor	Monitors Synthesizer's frequency ramp by counting (divided-down) clock cycles and comparing to ideal frequency ramp. Excess frequency errors above a certain threshold, if any, are detected and reported.
30	Ball break detection for TX ports (TX Ball break monitor)	Device architecture supports a ball break detection mechanism based on Impedance measurement at the TX output(s) to detect and report any large deviations that can indicate a ball break. Monitoring is done by TIs code running on BIST R4F and failure is reported to the MSS R4F via Mailbox. It is completely up to customer SW to decide on the appropriate action based on the message from BIST R4F.
31	RX loopback test	Built-in TX to RX loopback to enable detection of failures in the RX path(s), including Gain, inter-RX balance, etc.
32	IF loopback test	Built-in IF (square wave) test tone input to monitor IF filter's frequency response and detect failure.
33	RX saturation detect	Provision to detect ADC saturation due to excessive incoming signal level and/or interference.
34	Boot time LBIST for DSP core	Device device supports boot time LBIST for the DSP Core. LBIST can be triggered by the MSS R4F application code during boot time.

- (1) Monitoring is done by the TI's code running on BIST R4F. There are two modes in which it could be configured to report the temperature sensed via API by customer application.
- a. Report the temperature sensed after every N frames
  - b. Report the condition once the temperature crosses programmed threshold.

It is completely up to customer SW to decide on the appropriate action based on the message from BIST R4F via Mailbox.

- (2) Monitoring is done by the TI's code running on BIST R4F. There are two modes in which it could be configured to report the detected output power via API by customer application.
- a. Report the power detected after every N frames
  - b. Report the condition once the output power degrades by more than configured threshold from the configured.

It is completely up to customer SW to decide on the appropriate action based on the message from BIST R4F.

---

**Note**

Refer to the Device Safety Manual or other relevant collaterals for more details on applicability of all diagnostics mechanisms. For Certification details, refer to the device product page.

---

### 9.1.1 Error Signaling Module

When a diagnostic detects a fault, the error must be indicated. AWR6843AOP architecture provides aggregation of fault indication from internal diagnostic mechanisms using a peripheral logic known as the error signaling module (ESM). The ESM provides mechanisms to classify faults by severity and allows programmable error response. Below is the high level block diagram for ESM module.

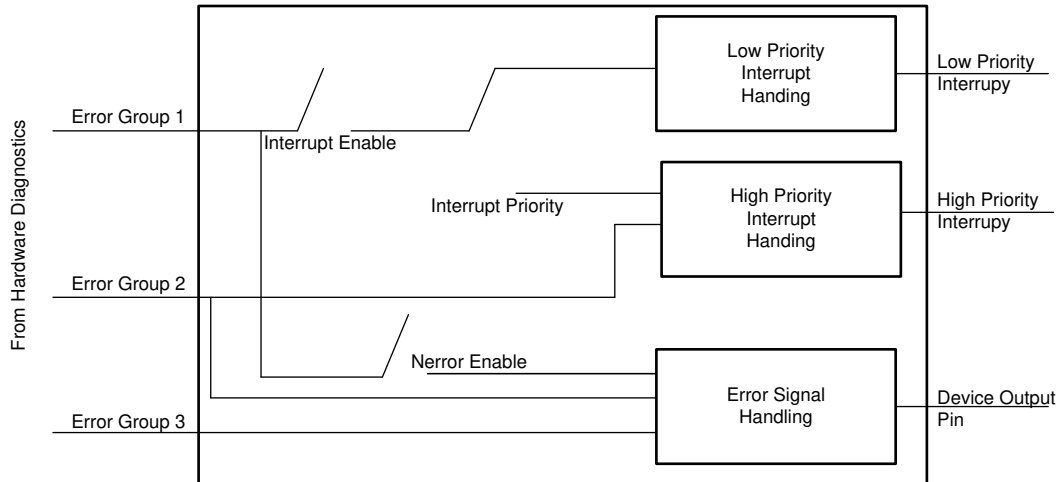

**Figure 9-1. ESM Module Diagram**

## 10 Applications, Implementation, and Layout

---

### Note

Information in the following Applications section is not part of the TI component specification, and TI does not warrant its accuracy or completeness. TI's customers are responsible for determining suitability of components for their purposes. Customers should validate and test their design implementation to confirm system functionality.

---

### 10.1 Application Information

Application information can be found on [AWR Application web page](#).

### 10.2 Reference Schematic

The reference schematic and power supply information can be found in the [AWR6843AOP EVM Documentation](#).

Listed for convenience are: Design Files, Schematics, Layouts, and Stack up for PCB.

- [Altium XWR6843 EVM Design Files](#)
- [XWR6843 EVM Schematic Drawing, Assembly Drawing, and Bill of Materials](#)

## 11 Device and Documentation Support

TI offers an extensive line of development tools. Tools and software to evaluate the performance of the device, generate code, and develop solutions follow.

### 11.1 Device Nomenclature

To designate the stages in the product development cycle, TI assigns prefixes to the part numbers of all microprocessors (MPUs) and support tools. Each device has one of three prefixes: X, P, or null (no prefix) (for example, *AWR6843AOP*). Texas Instruments recommends two of three possible prefix designators for its support tools: TMDX and TMDS. These prefixes represent evolutionary stages of product development from engineering prototypes (TMDX) through fully qualified production devices and tools (TMDS).

Device development evolutionary flow:

- XA** Experimental device that is not necessarily representative of the final device's electrical specifications and may not use production assembly flow.
- P** Prototype device that is not necessarily the final silicon die and may not necessarily meet final electrical specifications.
- null** Production version of the silicon die that is fully qualified.

Support tool development evolutionary flow:

- TMDX** Development-support product that has not yet completed Texas Instruments internal qualification testing.
- TMDS** Fully-qualified development-support product.

XA and P devices and TMDX development-support tools are shipped against the following disclaimer:

"Developmental product is intended for internal evaluation purposes."

Production devices and TMDS development-support tools have been characterized fully, and the quality and reliability of the device have been demonstrated fully. TI's standard warranty applies.

Predictions show that prototype devices (XA or P) have a greater failure rate than the standard production devices. Texas Instruments recommends that these devices not be used in any production system because their expected end-use failure rate still is undefined. Only qualified production devices are to be used.

TI device nomenclature also includes a suffix with the device family name. This suffix indicates the package type (for example, ALP0180), the temperature range (for example, blank is the default automotive temperature range). [Figure 11-1](#) provides a legend for reading the complete device name for any *AWR6843AOP* device.

For orderable part numbers of *AWR6843AOP* devices in the ALP0180 package types, see the Package Option Addendum of this document, the TI website ([www.ti.com](http://www.ti.com)), or contact your TI sales representative.

For additional description of the device nomenclature markings on the die, see the [AWR6843AOP Device Errata](#).

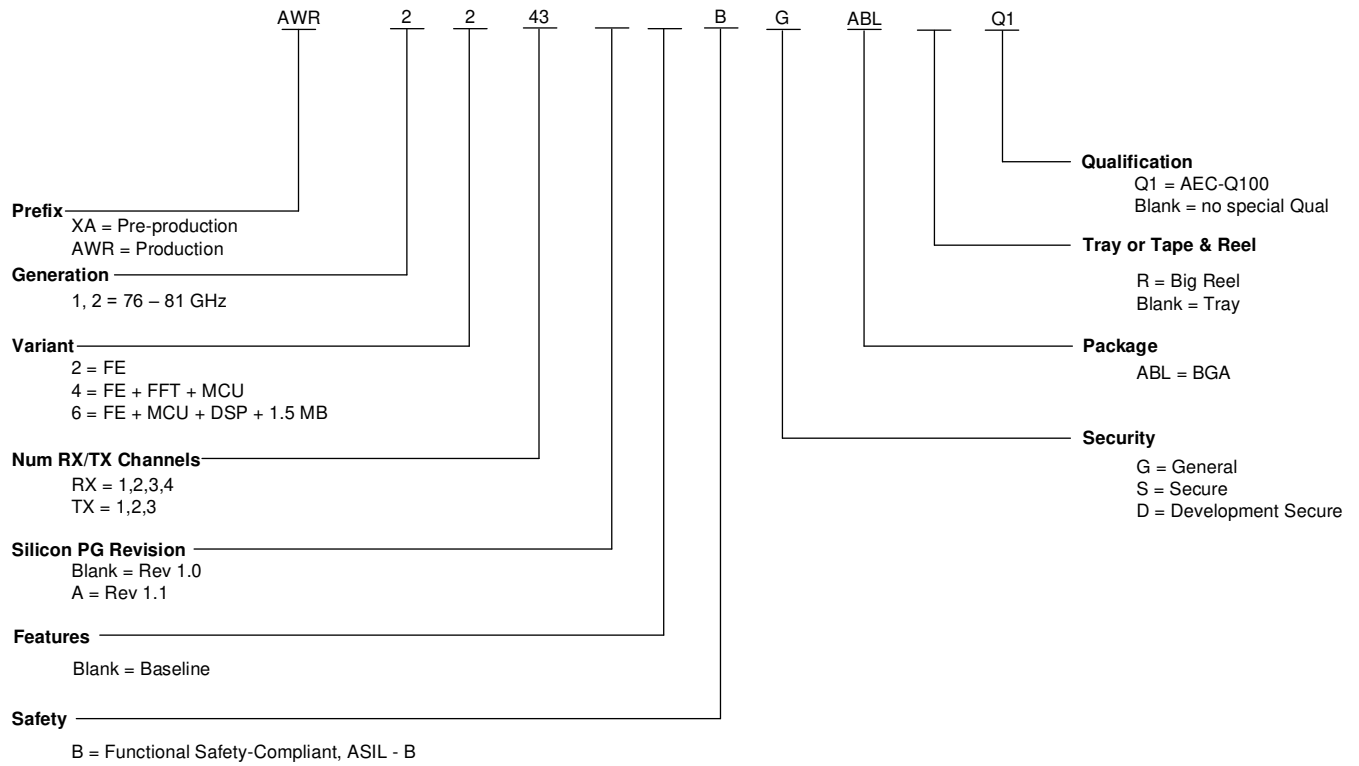

**Figure 11-1. Device Nomenclature**

## 11.2 Tools and Software

### Models

<a href="#">xWR6843AOP BSDL model</a>	Boundary scan database of testable input and output pins for IEEE 1149.1 of the specific device.
<a href="#">xWR6843AOP IBIS model</a>	IO buffer information model for the IO buffers of the device. For simulation on a circuit board, see IBIS Open Forum.
<a href="#">xWR6843AOP checklist for schematic review, layout review,bringup/wakeup</a>	A set of steps in spreadsheet form to select system functions and pinmux options. Specific EVM schematic and layout notes to apply to customer engineering. A bring up checklist is suggested for customers.

## 11.3 Documentation Support

To receive notification of documentation updates, navigate to the device product folder on [ti.com](http://ti.com). Click on *Notifications* to register and receive a weekly digest of any product information that has changed. For change details, review the revision history included in any revised document.

The current documentation that describes the DSP, related peripherals, and other technical collateral follows.

### Errata

[AWR6843AOP Device Errata](#) Describes known advisories, limitations, and cautions on silicon and provides workarounds.

## 11.4 Support Resources

[TI E2E™ support forums](#) are an engineer's go-to source for fast, verified answers and design help — straight from the experts. Search existing answers or ask your own question to get the quick design help you need.

Linked content is provided "AS IS" by the respective contributors. They do not constitute TI specifications and do not necessarily reflect TI's views; see TI's [Terms of Use](#).

## 11.5 Trademarks

TI E2E™ is a trademark of Texas Instruments.

Arm® and Cortex® are registered trademarks of Arm Limited (or its subsidiaries) in the US and/or elsewhere. All trademarks are the property of their respective owners.

## 11.6 Electrostatic Discharge Caution



This integrated circuit can be damaged by ESD. Texas Instruments recommends that all integrated circuits be handled with appropriate precautions. Failure to observe proper handling and installation procedures can cause damage.

ESD damage can range from subtle performance degradation to complete device failure. Precision integrated circuits may be more susceptible to damage because very small parametric changes could cause the device not to meet its published specifications.

## 11.7 Glossary

[TI Glossary](#) This glossary lists and explains terms, acronyms, and definitions.

## 12 Revision History

### Changes from July 31, 2022 to May 1, 2025 (from Revision C (July 2022) to Revision D (May 2025))

	<b>Page</b>
• Applications: Applications updated.....	2
• <a href="#">Figure 4-1</a> : Updated block diagram.....	3
• ( <i>Device Comparison</i> ) AWRL6432 and AWRL1432 devices added.....	5
• (VPP Specification for One-Time Programmable (OTP) eFuses): Section added.....	28
• (Power Save Mode): Section added.....	28
• RF Specification: Phase noise updated to -93dBc/Hz from -92dBc/Hz.....	34
• RF Specification: Transmitter EIRP number updated to 16dBm from 15dBm.....	34
• <a href="#">Figure 7-5</a> (Device Wake-Up Sequence): Logic diagram updated.....	39
• Updated/Changed Frequency tolerance from "-50 and 50" to "-200 to 200".....	41
• ( <i>QSPI Timings</i> ): Updated QSPI cycle time from 25 to 12.5.....	59
• (Boot Modes): Section added.....	70

**Changes from June 2, 2021 to July 31, 2022 (from Revision B (June 2021) to Revision C (July 2022))**
**Page**

• <i>(Features)</i> : Updated Functional-Safety Compliance Certification Collateral; Details on Device Security added; Mentioned the specific operating temperature range for the mmWave Sensor.....	1
• <i>(Description)</i> : Updated/Changed Description to add more details about the device subsystems.....	2
• <i>(Device Comparison)</i> Removed information on Functional-Safety compliance from the table and instead added a table-note for this and LVDS Interface; Additional information on Device security updated.....	5
• <i>(QSPI Timings)</i> :Updated/Changed Setup Time from 7.3us to 5us and Hold Time from 1.5us to 1us for QSPI Timings.....	58
• <i>(QSPI Timings)</i> : Updated/Changed <i>Delay time, sclk falling edge to d[1] transition i.e. [Q6, Q9]</i> from -3.5us to -2.5us (Min) and 7us to 4us (Max) in QSPI Switching Characteristics.....	59
• <i>(Monitoring and Diagnostic Mechanisms)</i> : Updated/Changed table header and description to reflect Functional Safety-Compliance; added a note for reference to safety related collateral .....	74

## 13 Mechanical, Packaging, and Orderable Information

### 13.1 Packaging Information

The following pages include mechanical, packaging, and orderable information. This information is the most current data available for the designated devices. This data is subject to change without notice and revision of this document. For browser-based versions of this data sheet, refer to the left-hand navigation.

#### Note

Variability in the color (or appearance) of Texas Instrument’s (TI’s) Antenna-on-Package (AoP) product is normal and expected. This variation is not indicative of any degradation or variability to the performance specifications of the AoP products.

### 13.2 Tray Information for ALP, 15 × 15 mm

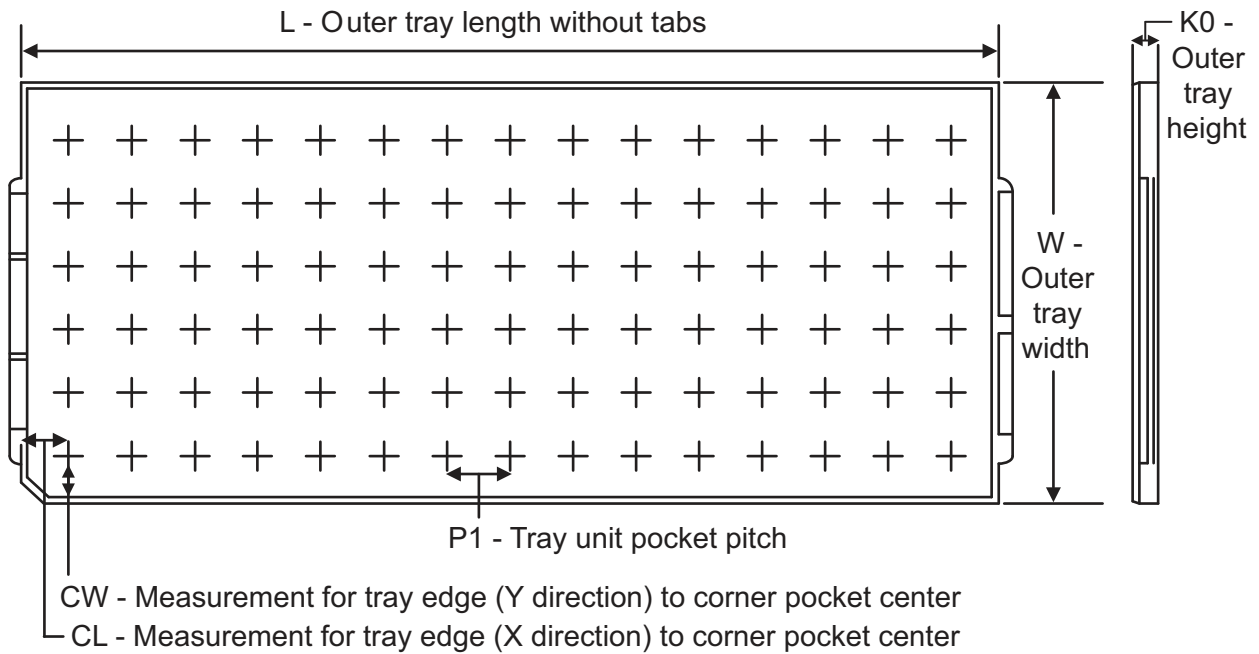

Chamfer on Tray corner indicates Pin 1 orientation of packed units.

Device	Package Type	Package Name	Pins	SPQ	Unit Array Matrix	Max Temp. (°C)	L (mm)	W (mm)	K0 (mm)	P1 (mm)	CL (mm)	CW (mm)
AWR6843ARBGALPQ1	FCBGA	ALP	180	126	7x18	150	315	135.9	7.62	17.2	11.30	16.35
AWR6843ARBSALPQ1	FCBGA	ALP	180	126	7x18	150	315	135.9	7.62	17.2	11.30	16.35

**PACKAGING INFORMATION**

Orderable part number	Status (1)	Material type (2)	Package   Pins	Package qty   Carrier	RoHS (3)	Lead finish/ Ball material (4)	MSL rating/ Peak reflow (5)	Op temp (°C)	Part marking (6)
<a href="#">AWR6843ARBGALPQ1</a>	Active	Production	FCCSP (ALP)   180	126   JEDEC TRAY (5+1)	Yes	Call TI	Level-3-260C-168 HR	-40 to 125	ABG WR6843
AWR6843ARBGALPQ1.B	Active	Production	FCCSP (ALP)   180	126   JEDEC TRAY (5+1)	Yes	Call TI	Level-3-260C-168 HR	-40 to 125	ABG WR6843
<a href="#">AWR6843ARBGALPRQ1</a>	Active	Production	FCCSP (ALP)   180	1000   LARGE T&R	Yes	Call TI	Level-3-260C-168 HR	-40 to 125	ABG WR6843
AWR6843ARBGALPRQ1.B	Active	Production	FCCSP (ALP)   180	1000   LARGE T&R	Yes	Call TI	Level-3-260C-168 HR	-40 to 125	ABG WR6843
AWR6843ARBSALPQ1	Active	Production	FCCSP (ALP)   180	126   JEDEC TRAY (5+1)	Yes	Call TI	Level-3-260C-168 HR	-40 to 125	ABS WR6843

(1) **Status:** For more details on status, see our [product life cycle](#).

(2) **Material type:** When designated, preproduction parts are prototypes/experimental devices, and are not yet approved or released for full production. Testing and final process, including without limitation quality assurance, reliability performance testing, and/or process qualification, may not yet be complete, and this item is subject to further changes or possible discontinuation. If available for ordering, purchases will be subject to an additional waiver at checkout, and are intended for early internal evaluation purposes only. These items are sold without warranties of any kind.

(3) **RoHS values:** Yes, No, RoHS Exempt. See the [TI RoHS Statement](#) for additional information and value definition.

(4) **Lead finish/Ball material:** Parts may have multiple material finish options. Finish options are separated by a vertical ruled line. Lead finish/Ball material values may wrap to two lines if the finish value exceeds the maximum column width.

(5) **MSL rating/Peak reflow:** The moisture sensitivity level ratings and peak solder (reflow) temperatures. In the event that a part has multiple moisture sensitivity ratings, only the lowest level per JEDEC standards is shown. Refer to the shipping label for the actual reflow temperature that will be used to mount the part to the printed circuit board.

(6) **Part marking:** There may be an additional marking, which relates to the logo, the lot trace code information, or the environmental category of the part.

Multiple part markings will be inside parentheses. Only one part marking contained in parentheses and separated by a "~" will appear on a part. If a line is indented then it is a continuation of the previous line and the two combined represent the entire part marking for that device.

**Important Information and Disclaimer:** The information provided on this page represents TI's knowledge and belief as of the date that it is provided. TI bases its knowledge and belief on information provided by third parties, and makes no representation or warranty as to the accuracy of such information. Efforts are underway to better integrate information from third parties. TI has taken and continues to take reasonable steps to provide representative and accurate information but may not have conducted destructive testing or chemical analysis on incoming materials and chemicals. TI and TI suppliers consider certain information to be proprietary, and thus CAS numbers and other limited information may not be available for release.

In no event shall TI's liability arising out of such information exceed the total purchase price of the TI part(s) at issue in this document sold by TI to Customer on an annual basis.

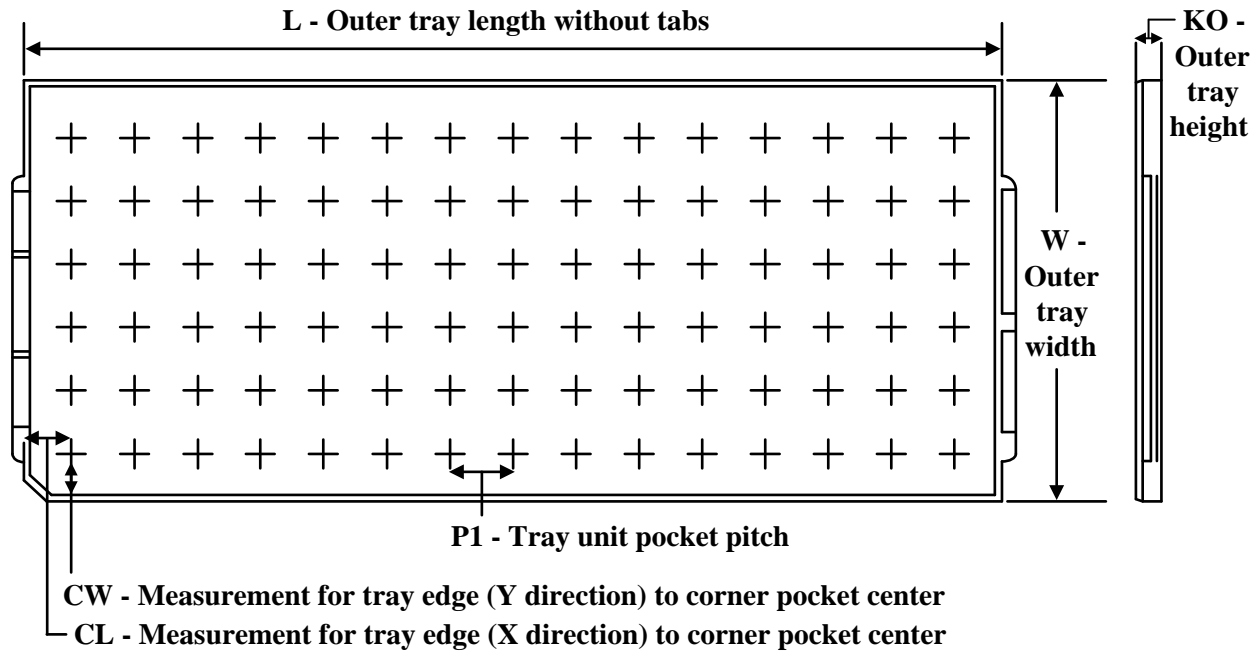
**TRAY**

Chamfer on Tray corner indicates Pin 1 orientation of packed units.

\*All dimensions are nominal

Device	Package Name	Package Type	Pins	SPQ	Unit array matrix	Max temperature (°C)	L (mm)	W (mm)	K0 (µm)	P1 (mm)	CL (mm)	CW (mm)
AWR6843ARBGALPQ1	ALP	FCCSP	180	126	7 X 18	150	315	135.9	7620	17.2	11.3	16.35
AWR6843ARBGALPQ1.E	ALP	FCCSP	180	126	7 X 18	150	315	135.9	7620	17.2	11.3	16.35

# ALP0180A

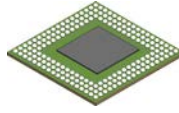

# PACKAGE OUTLINE

FCCSP - 0.965 mm max height

PLASTIC BALL GRID ARRAY

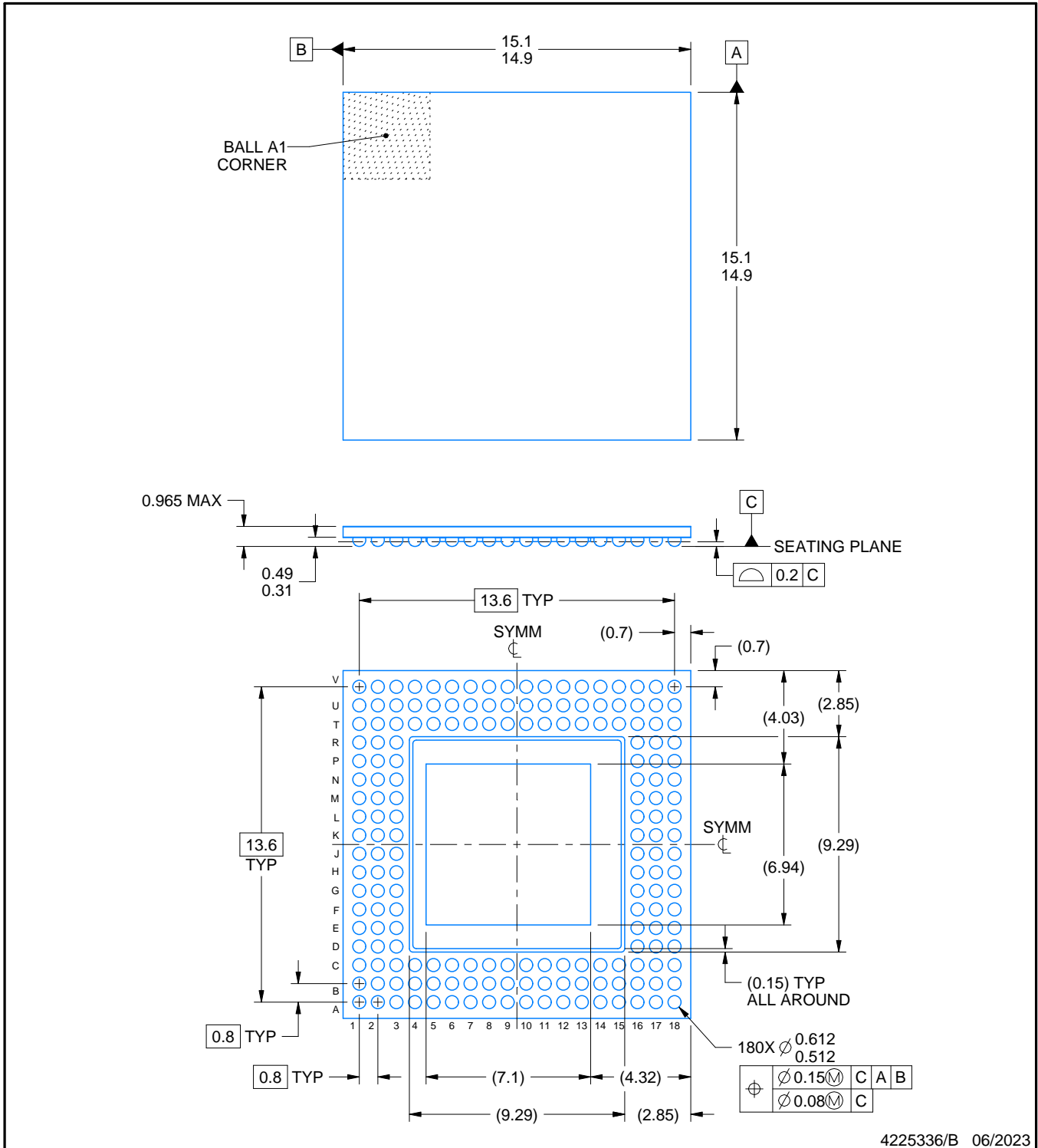

**NOTES:**

1. All linear dimensions are in millimeters. Any dimensions in parenthesis are for reference only. Dimensioning and tolerancing per ASME Y14.5M.
2. This drawing is subject to change without notice.

# EXAMPLE BOARD LAYOUT

ALP0180A

FCCSP - 0.965 mm max height

PLASTIC BALL GRID ARRAY

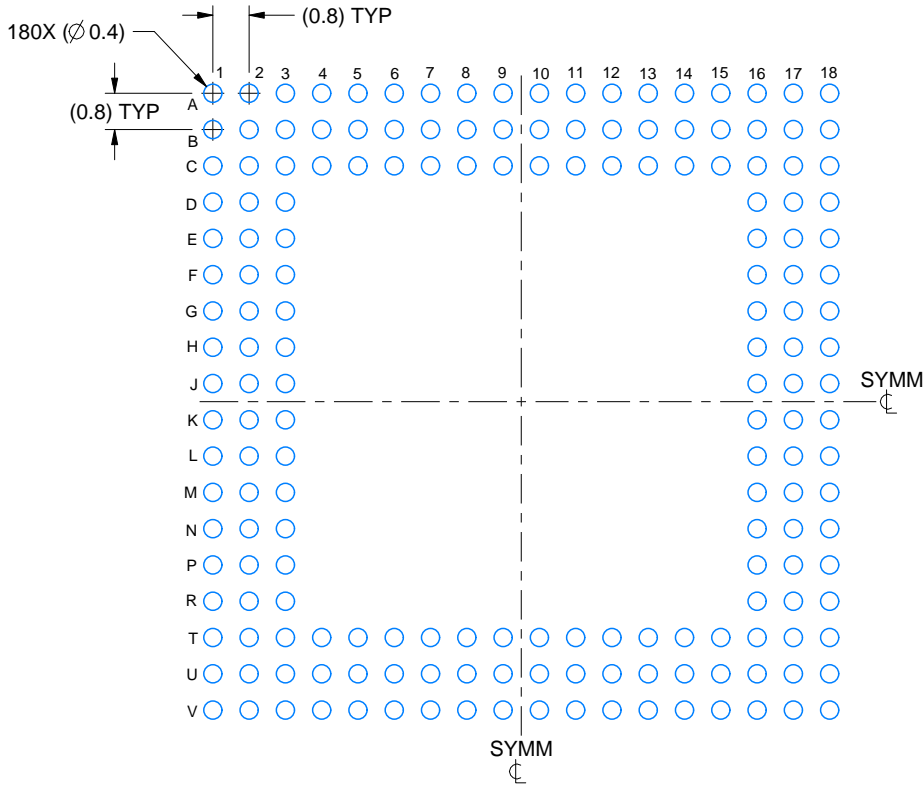

## LAND PATTERN EXAMPLE

EXPOSED METAL SHOWN  
SCALE: 6X

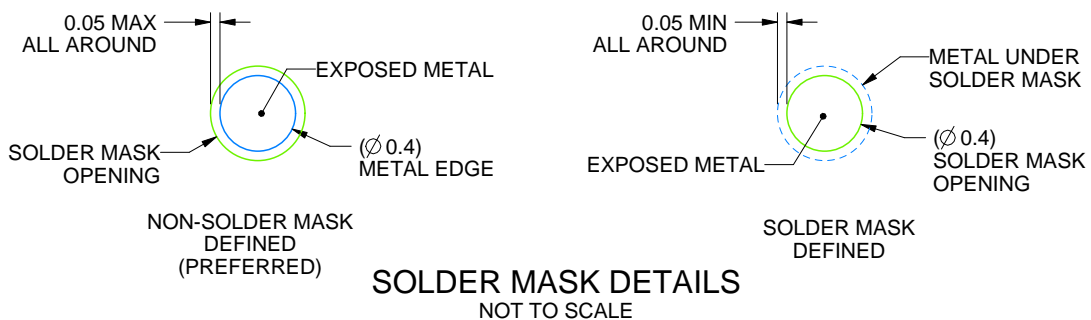

4225336/B 06/2023

NOTES: (continued)

- Final dimensions may vary due to manufacturing tolerance considerations and also routing constraints. For information, see Texas Instruments literature number SPRAA99 ([www.ti.com/lit/spraa99](http://www.ti.com/lit/spraa99)).

# EXAMPLE STENCIL DESIGN

## ALP0180A

### FCCSP - 0.965 mm max height

PLASTIC BALL GRID ARRAY

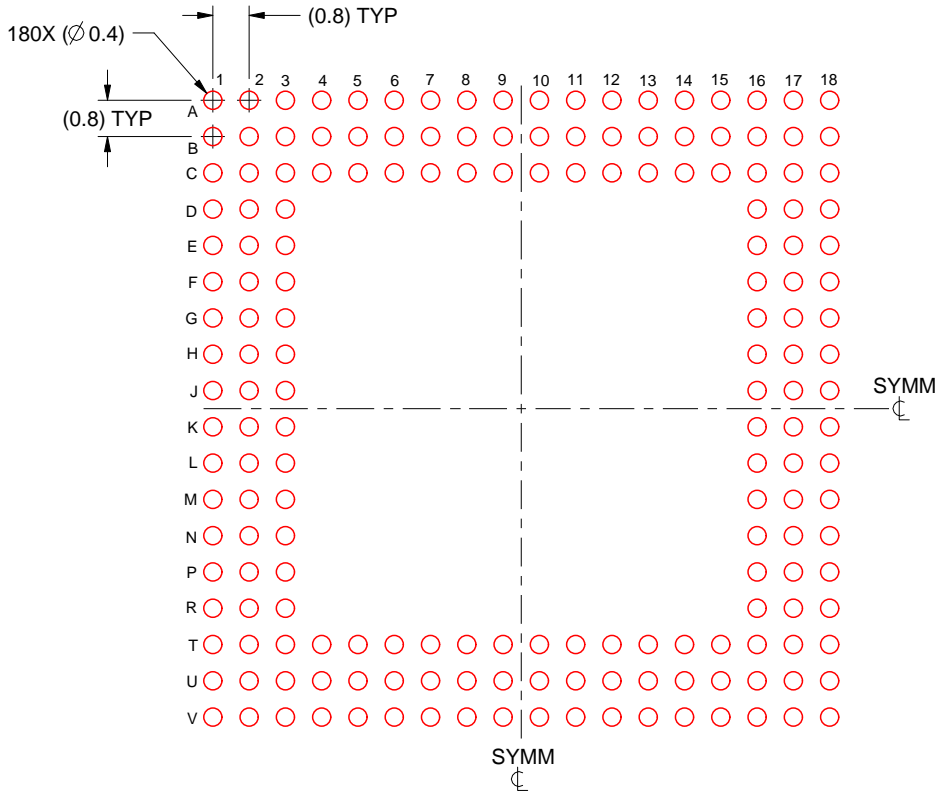

**SOLDER PASTE EXAMPLE**  
BASED ON 0.125 mm THICK STENCIL  
SCALE: 6X

4225336/B 06/2023

NOTES: (continued)

4. Laser cutting apertures with trapezoidal walls and rounded corners may offer better paste release.

## IMPORTANT NOTICE AND DISCLAIMER

TI PROVIDES TECHNICAL AND RELIABILITY DATA (INCLUDING DATASHEETS), DESIGN RESOURCES (INCLUDING REFERENCE DESIGNS), APPLICATION OR OTHER DESIGN ADVICE, WEB TOOLS, SAFETY INFORMATION, AND OTHER RESOURCES "AS IS" AND WITH ALL FAULTS, AND DISCLAIMS ALL WARRANTIES, EXPRESS AND IMPLIED, INCLUDING WITHOUT LIMITATION ANY IMPLIED WARRANTIES OF MERCHANTABILITY, FITNESS FOR A PARTICULAR PURPOSE OR NON-INFRINGEMENT OF THIRD PARTY INTELLECTUAL PROPERTY RIGHTS.

These resources are intended for skilled developers designing with TI products. You are solely responsible for (1) selecting the appropriate TI products for your application, (2) designing, validating and testing your application, and (3) ensuring your application meets applicable standards, and any other safety, security, regulatory or other requirements.

These resources are subject to change without notice. TI grants you permission to use these resources only for development of an application that uses the TI products described in the resource. Other reproduction and display of these resources is prohibited. No license is granted to any other TI intellectual property right or to any third party intellectual property right. TI disclaims responsibility for, and you fully indemnify TI and its representatives against any claims, damages, costs, losses, and liabilities arising out of your use of these resources.

TI's products are provided subject to [TI's Terms of Sale](#), [TI's General Quality Guidelines](#), or other applicable terms available either on [ti.com](http://ti.com) or provided in conjunction with such TI products. TI's provision of these resources does not expand or otherwise alter TI's applicable warranties or warranty disclaimers for TI products. Unless TI explicitly designates a product as custom or customer-specified, TI products are standard, catalog, general purpose devices.



TI objects to and rejects any additional or different terms you may propose.

Copyright © 2026, Texas Instruments Incorporated

Last updated 10/2025

## Looking for pricing, stock, or lifecycle information?

Click below to explore more details on WIN SOURCE:

-  [View BUK4D16-20X on WIN SOURCE](#)
-  [Nexperia USA Inc. Information](#)

## Optimize Your Supply Chain with WIN SOURCE Solutions

-  Global Sourcing Solution
-  Obsolete Management
-  Cost Control Management
-  Shortage Management
-  Alternative Solution
-  Excess Inventory Management