



**THE DATASHEET OF
CS5173GDR8**





Please note that Cypress is an Infineon Technologies Company.

The document following this cover page is marked as “Cypress” document as this is the company that originally developed the product. Please note that Infineon will continue to offer the product to new and existing customers as part of the Infineon product portfolio.

Continuity of document content

The fact that Infineon offers the following product as part of the Infineon product portfolio does not lead to any changes to this document. Future revisions will occur when appropriate, and any changes will be set out on the document history page.

Continuity of ordering part numbers

Infineon continues to support existing part numbers. Please continue to use the ordering part numbers listed in the datasheet for ordering.

General Description

The Cypress CYBLE-224116-01 is a fully certified and qualified module supporting Bluetooth® Low Energy wireless communication. The CYBLE-224116-01 is a turnkey solution that includes onboard power amplifier (PA), low noise amplifier (LNA), crystal oscillators, chip antenna, passive components, and the Cypress PSoC 4 Bluetooth LE. Refer to the PSoC 4 Bluetooth LE [datasheet](#) for additional details on the capabilities of the PSoC 4 Bluetooth LE device used on this module.

The EZ-BLE™ Creator XT/XR module provides extended industrial temperature operation (XT) as well as extended communication range (XR). The EZ-BLE XT/XR module is a scalable and reconfigurable platform architecture, combining programmable and reconfigurable analog and digital blocks with flexible automatic routing. The CYBLE-224116-01 also includes digital programmable logic, high-performance analog-to-digital conversion (ADC), opamps with comparator mode, and standard communication and timing peripherals. The CYBLE-224116-01 includes a royalty-free Bluetooth LE stack compatible with Bluetooth 5.1.

Module Description

- Module size: 9.5 mm × 15.4 mm × 1.80 mm (with shield)
 - Drop-in compatible with [CYBLE-224110-00](#) (XT/XR 4.1)
- Extended Range:
 - Up to 400 meters bidirectional communication^[1, 2]
 - Up to 450 meters in beacon only mode^[1]
- Extended industrial temperature range: -40 °C to +105 °C
- Up to 25 GPIOs
- 256-KB flash memory, 32-KB SRAM memory
- Bluetooth 5.1 qualified single-mode module
 - QDID: [167535](#)
 - Declaration ID: [D054769](#)
- Certified to FCC, CE, MIC, KC, and ISED regulations
- 32-bit processor (0.9 DMIPS/MHz) operating at up to 48 MHz
- Watchdog timer with dedicated internal low-speed oscillator

Power Consumption

- TX output power: -18 dBm to +9.5 dBm
- RX Receive Sensitivity: -95 dBm
- Received signal strength indicator (RSSI) with 1-dB resolution
- 1 Second connection interval with PA/LNA active: 26.3 µA
- TX current consumption:
 - Bluetooth LE silicon: 15.6 mA (radio only, 0 dBm)
 - SE2438T: 20 mA (PA/LNA only, +9.5 dBm)

Notes

1. Connection range tested module-to-module in full line-of-sight environment, free of obstacles or interference sources with output power of +9.5 dBm.
2. Specified as EZ-BLE XT/XR module to module range. Mobile phone connection will decrease based on the PA/LNA performance of the mobile phone used.

- RX current consumption of 16.4 mA (radio only)
 - Bluetooth LE silicon: 16.4 mA (radio only)
 - SE2438T: 5.5 mA (PA/LNA only)
- Low power mode support
 - Deep Sleep: 1.3 µA with watch crystal oscillator (WCO) on
 - Hibernate: 150 nA with SRAM retention
 - Stop: 60 nA with XRES wakeup

Integrated PA/LNA

- Supports output power up to +9.5 dBm and RX_S of -95 dBm

Programmable Analog

- Four opamps with reconfigurable high-drive external and high-bandwidth internal drive, comparator modes, and ADC input buffering capability; can operate in Deep-Sleep mode
- 12-bit, 1-Msps SAR ADC with differential and single-ended modes; channel sequencer with signal averaging
- Two current DACs (IDACs) for general-purpose or capacitive sensing applications on any pin
- One low-power comparator that operate in Deep-Sleep mode

Programmable Digital

- Four programmable logic blocks called universal digital blocks, (UDBs), each with eight macrocells and datapath
- Cypress-provided peripheral Component library, user-defined state machines, and Verilog input

Capacitive Sensing

- Cypress CapSense Sigma-Delta (CSD) provides best-in-class SNR (> 5:1) and liquid tolerance

Segment LCD Drive

- LCD drive supported on all GPIOs (common or segment)
- Operates in Deep-Sleep mode with four bits per pin memory

Serial Communication

- Two independent runtime reconfigurable serial communication blocks (SCBs) with I²C, SPI, or UART functionality

Timing and Pulse-Width Modulation

- Four 16-bit timer, counter, pulse-width modulator (TCPWM) blocks
- Center-aligned, Edge, and Pseudo-random modes

Up to 25 Programmable GPIOs

- Any GPIO pin can be CapSense, LCD, analog, or digital
- Two overvoltage-tolerant (OVT) pins; drive modes, strengths, and slew rates are programmable

More Information

Cypress provides a wealth of data at www.cypress.com to help you to select the right module for your design, and to help you to quickly and effectively integrate the module into your design.

- Overview: [EZ-BLE Module Portfolio](#), [Module Roadmap](#)
- [PSoC 4 Bluetooth LE Silicon Datasheet](#)
- Application notes: Cypress offers a number of Bluetooth LE application notes covering a broad range of topics, from basic to advanced level. Recommended application notes for getting started with EZ-BLE modules are:
 - [AN96841](#) - Getting Started with EZ-BLE Module
 - [AN91267](#) - Getting Started with PSoC[®] 4 Bluetooth LE
 - [AN97060](#) - PSoC[®] 4 Bluetooth LE and PRoC[™] Bluetooth LE - Over-The-Air (OTA) Device Firmware Upgrade (DFU) Guide
 - [AN91162](#) - Creating a Bluetooth LE Custom Profile
 - [AN91184](#) - PSoC 4 Bluetooth LE - Designing Bluetooth LE Ap PSoC 4 Bluetooth LE - Designing Bluetooth LE Applications
 - [AN92584](#) - Designing for Low Power and Estimating Battery Life for Bluetooth LE Applications
 - [AN85951](#) - PSoC[®] 4 CapSense[®] Design Guide
 - [AN95089](#) - PSoC[®] 4/PRoC[™] Bluetooth LE Crystal Oscillator Selection and Tuning Techniques
 - [AN91445](#) - Antenna Design and RF Layout Guidelines
- Technical Reference Manual (TRM):
 - PSoC[®] 4 Bluetooth LE [Technical Reference Manual](#)
 - PSoC[®] 4 Bluetooth LE Registers [Technical Reference Manual](#)
- PRoC[™] and PSoC[®] [Programming Specifications](#)
- Knowledge Base Article
 - [KBA216235](#) - Pin Mapping Differences Between the EZ-BLE[™] Creator Evaluation Board (CYBLE-224116-EVAL) and the Bluetooth LE Pioneer Kit (CY8CKIT-042-Bluetooth LE)
 - [KBA97095](#) - EZ-BLE[™] Module Placement
 - [KBA213260](#) - RF Regulatory Certifications for CYBLE-224110-00 and CYBLE-224116-01 EZ-BLE[™] Creator XT/XR Modules
 - [KBA213976](#) - FAQ for Bluetooth LE and Regulatory Certifications with EZ-BLE modules
 - [KBA210802](#) - Queries on Bluetooth LE Qualification and Declaration Processes
 - [KBA2108122](#) - 3D Model Files for EZ-BLE/EZ-BT Modules
- Development Kits:
 - [CYBLE-224116-EVAL](#), CYBLE-224116-01 Evaluation Board
 - [CY8CKIT-042-Bluetooth LE](#), Bluetooth Low Energy Pioneer Kit
 - [CY8CKIT-002](#), PSoC[®] MiniProg3 Program and Debug Kit
- Test and Debug Tools:
 - [CYSmart](#), Bluetooth LE Test and Debug Tool (Windows)
 - [CYSmart Mobile](#), Bluetooth LE Test and Debug Tool (Android/iOS Mobile App)

Two Design Environments to Get You Started Quickly

PSoC[®] Creator[™] Integrated Design Environment (IDE)

[PSoC Creator](#) is an Integrated Design Environment (IDE) that enables concurrent hardware and firmware editing, compiling and debugging of PSoC 3, PSoC 4, PSoC 5LP, PSoC 4 Bluetooth LE, and EZ-BLE module systems with no code size limitations. PSoC peripherals are designed using schematic capture and simple graphical user interface (GUI) with over 120 pre-verified, production-ready PSoC Components[™]. PSoC Components are analog and digital “virtual chips” represented by an icon that users can drag-and-drop into a design and configure to suit a broad array of application requirements.

Bluetooth Low Energy Component

The [Bluetooth Low Energy Component](#) inside PSoC Creator provides a comprehensive GUI-based configuration window that lets you quickly design Bluetooth LE applications. The Component incorporates a Bluetooth Core Specification v5.1 compliant Bluetooth LE protocol stack and provides API functions to enable user applications to interface with the underlying Bluetooth Low Energy Sub-System (BLESS) hardware via the stack.

EZ-Serial[™] Bluetooth LE Firmware Platform

The [EZ-Serial Firmware Platform](#) provides a simple way to access the most common hardware and communication features needed in Bluetooth LE applications. EZ-Serial implements an intuitive API protocol over the UART interface and exposes various status and control signals through the module’s GPIOs, making it easy to add Bluetooth LE functionality quickly to existing designs.

Use a simple serial terminal and evaluation kit to begin development without requiring an IDE. Refer to the EZ-Serial webpage for User Manuals and instructions for getting started as well as detailed reference materials.

EZ-BLE modules are pre-flashed with the EZ-Serial Firmware Platform. If you do not have EZ-Serial pre-loaded on your module, you can download each EZ-BLE module’s firmware images on the [EZ-Serial webpage](#).

Technical Support

- [Frequently Asked Questions \(FAQs\)](#): Learn more about our Bluetooth LE ECO System.
- [Forum](#): See if your question is already answered by fellow developers on the PSoC 4 Bluetooth LE.
- Visit our [support](#) page and create a [technical support case](#) or contact a [local sales representatives](#). If you are in the United States, you can talk to our technical support team by calling our toll-free number: +1-800-541-4736. Select option 2 at the prompt.

Contents

Overview	4	Safety Certification	35
Module Description	4	Environmental Conditions	35
Pad Connection Interface	6	ESD and EMI Protection	35
Recommended Host PCB Layout	8	Regulatory Information	36
Digital and Analog Capabilities and Connections	10	FCC	36
Power Supply Connections		ISED	37
and Recommended External Components	12	European Declaration of Conformity	38
Connection Options	12	MIC Japan	38
External Component Recommendation	12	KC Korea	38
Critical Components List	15	Packaging	39
Antenna Design	15	Ordering Information	41
Enabling Extended Range Feature	16	Part Numbering Convention	41
Power Saving Measures with PA/LNA Operation	17	Acronyms	42
Electrical Specifications	18	Document Conventions	44
GPIO	20	Units of Measure	44
XRES	22	Document History Page	45
Analog Peripherals	22	Sales, Solutions, and Legal Information	47
Digital Peripherals	26	Worldwide Sales and Design Support	47
Serial Communication	28	Products	47
Memory	29	PSoC® Solutions	47
System Resources	29	Cypress Developer Community	47
Environmental Specifications	35	Technical Support	47
Environmental Compliance	35		
RF Certification	35		

Overview

Module Description

The CYBLE-224116-01 is an integrated wireless module designed to be soldered to the main host board.

Module Dimensions and Drawing

Cypress reserves the right to select components (including the appropriate Bluetooth LE device) from various vendors to achieve the Bluetooth LE module functionality. Such selections will guarantee that all height restrictions of the component area are maintained. Designs should be completed with the physical dimensions shown in the mechanical drawings in [Figure 1](#). All dimensions are in millimeters (mm).

Table 1. Module Design Dimensions

Dimension Item		Specification
Module dimensions	Length (X)	9.50 ± 0.15 mm
	Width (Y)	15.40 ± 0.15 mm
Antenna location dimensions	Length (X)	7.00 mm
	Width (Y)	5.00 mm
PCB thickness	Height (H)	0.50 ± 0.10 mm
Shield height	Height (H)	1.10 ± 0.10 mm
Maximum component height	Height (H)	1.30-mm typical (chip antenna)
Total module thickness (bottom of module to highest component)	Height (H)	1.80-mm typical

See [Figure 1](#) on [page 5](#) for the mechanical reference drawing for CYBLE-224116-01.

Figure 1. Module Mechanical Drawing

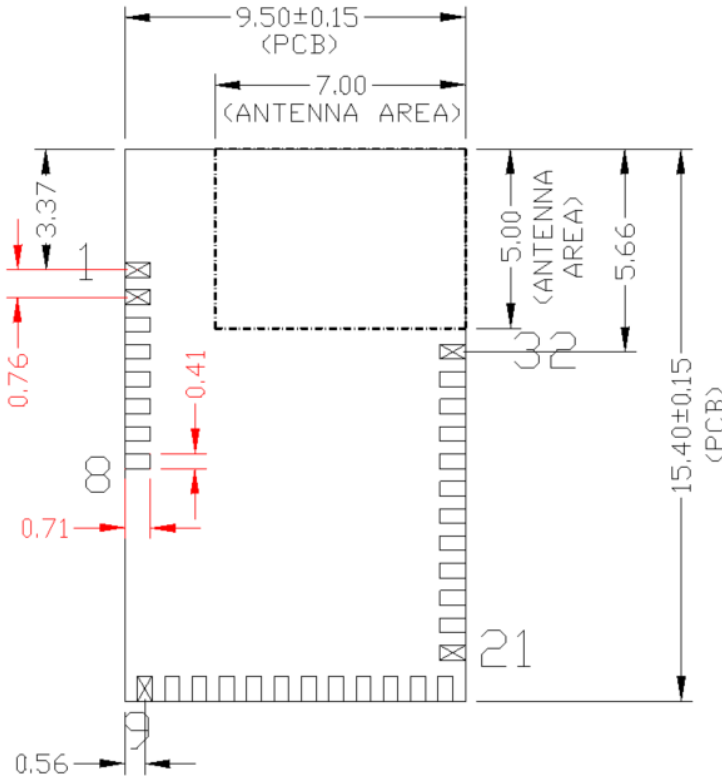
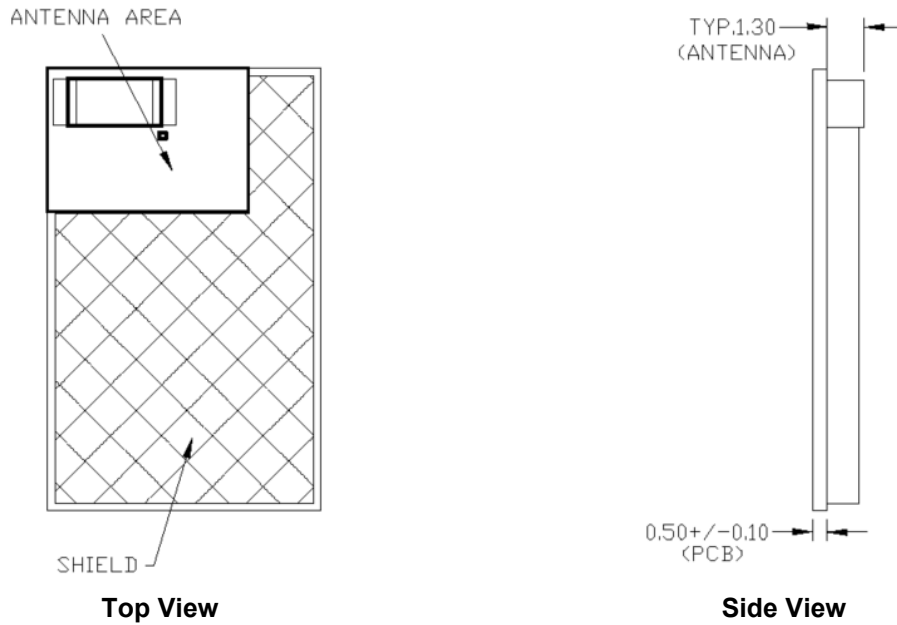

MODULE PAD ASSIGNMENT:

- PAD1:GND
- PAD2:XRES
- PAD3:P1.5
- PAD4:P1.1
- PAD5:P1.0
- PAD6:P0.1
- PAD7:P0.4
- PAD8:P0.5
- PAD9:P0.7
- PAD10:P1.3
- PAD11:VDDR
- PAD12:P0.6
- PAD13:P1.2
- PAD14:VDD
- PAD15:P1.4
- PAD16:P2.1
- PAD17:VDDA
- PAD18:P2.2
- PAD19:P2.6
- PAD20:P3.0
- PAD21:P2.3
- PAD22:VREF
- PAD23:P3.4
- PAD24:P3.5
- PAD25:P3.7
- PAD26:P3.1
- PAD27:P3.6
- PAD28:P2.5
- PAD29:P5.0
- PAD30:P5.1
- PAD31:P2.4
- PAD32:GND

Bottom View (Seen from Bottom)

Note

3. No metal should be located beneath or above the antenna area. Only bare PCB material should be located beneath the antenna area. For more information on recommended host PCB layout, see Figure 3, Figure 4, Figure 5, and Figure 6 and Table 3.

Pad Connection Interface

As shown in the bottom view of [Figure 1 on page 5](#), the CYBLE-224116-01 connects to the host board via solder pads on the back of the module. [Table 2](#) and [Figure 2](#) detail the solder pad length, width, and pitch dimensions of the CYBLE-224116-01 module.

Table 2. Solder Pad Connection Description

Name	Connections	Connection Type	Pad Length Dimension	Pad Width Dimension	Pad Pitch
SP	32	Solder Pads	0.71 mm	0.41 mm	0.76 mm

Figure 2. Solder Pad Dimensions (Seen from Bottom)

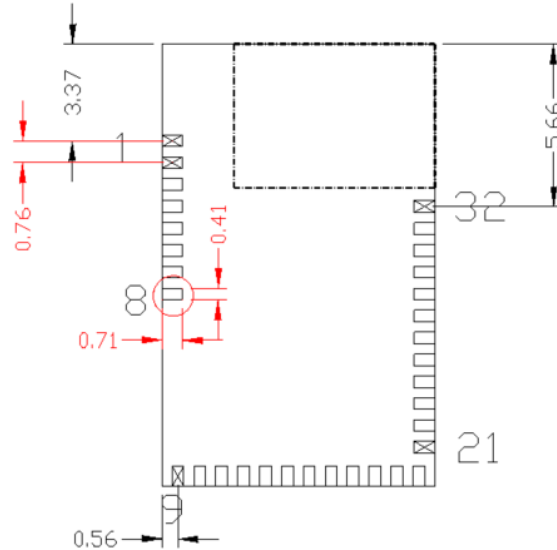

To maximize RF performance, the host layout should follow these recommendations:

1. The ideal placement of the Cypress Bluetooth LE module is in a corner of the host board with the antenna located on the edge of the host board. This placement minimizes the additional recommended keep-out area shown in item 2. Refer to [AN96841](#) for module placement best practices.
2. To maximize RF performance, the area immediately around the Cypress Bluetooth LE module chip antenna should contain an additional keep-out area, where no grounding or signal traces are contained. The keep-out area applies to all layers of the host board. The recommended dimensions of the host PCB keep-out area are shown in [Figure 3](#) (dimensions are in mm).

Figure 3. Recommended Host PCB Keep-Out Area Around the CYBLE-224116-01 Chip Antenna

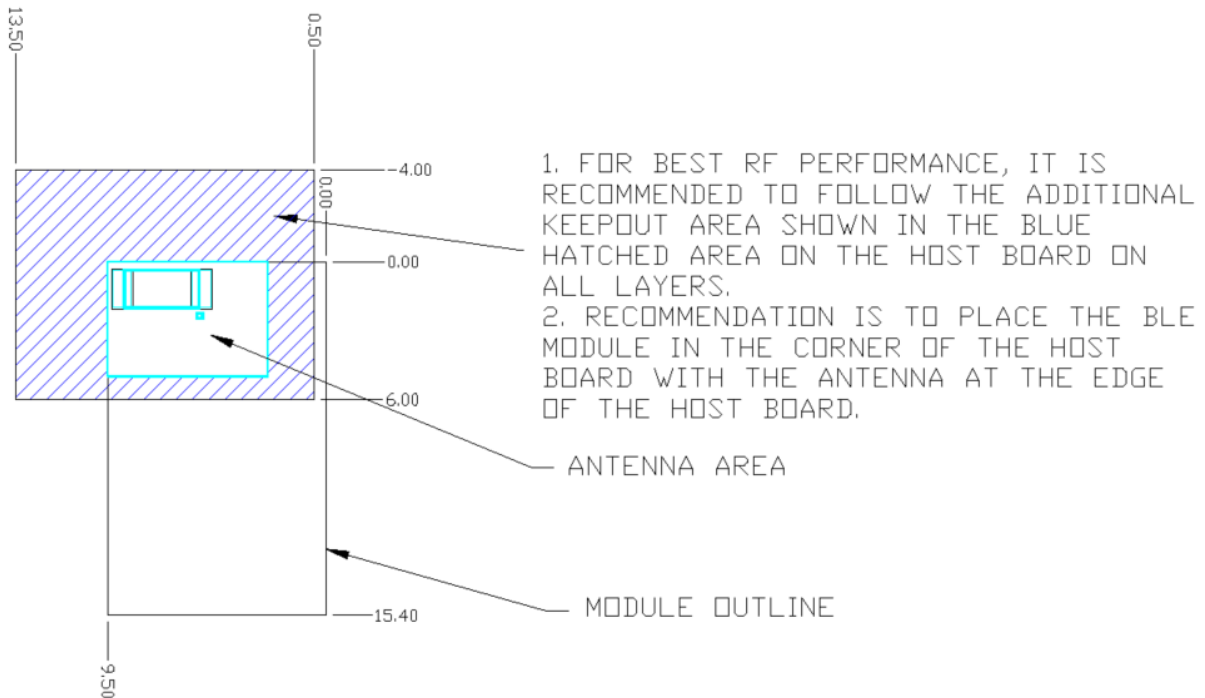

Host PCB Keep-Out Area Around Chip Antenna

Recommended Host PCB Layout

Figure 4, Figure 5, Figure 6, and Table 3 provide details that can be used for the recommended host PCB layout pattern for the CYBLE-224116-01. Dimensions are in millimeters unless otherwise noted. The minimum recommended host PCB pad length is 0.91 mm (0.455 mm from center of the pad to either side) is recommended as shown in Figure 6. The host PCB layout pattern can be completed using either Figure 4, Figure 5, or Figure 6. It is not necessary to use all figures to complete the host PCB layout pattern.

Figure 4. Host Layout Pattern for CYBLE-224116-01

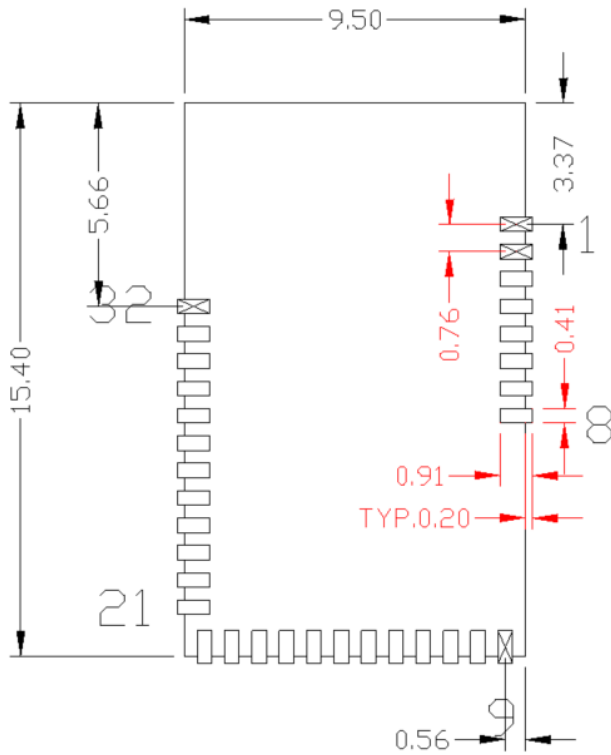

Top View (Seen on Host PCB)

Figure 5. Module Pad Location from Origin

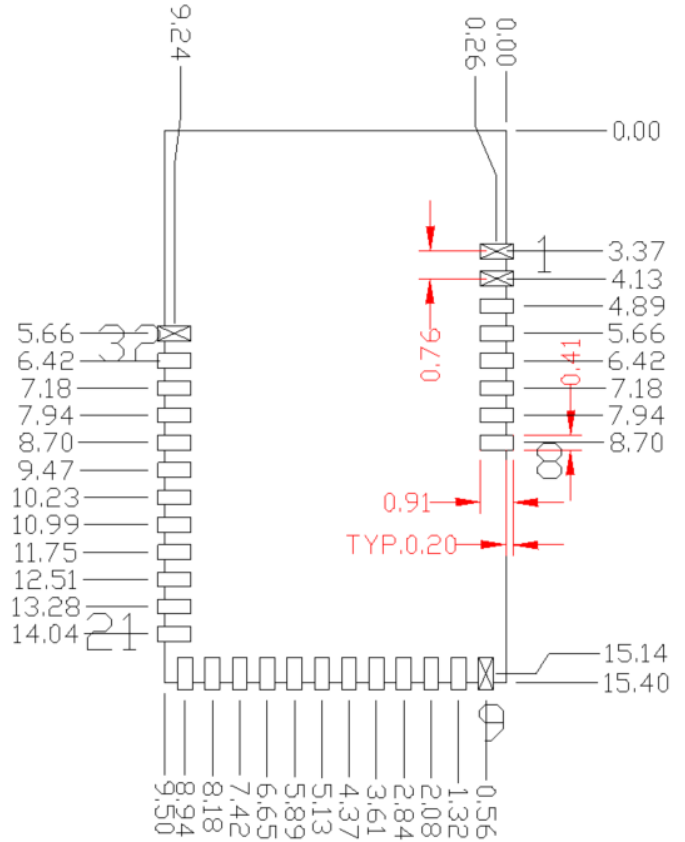

Top View (Seen on Host PCB)

Table 3 provides the center location for each solder pad on the CYBLE-224116-01. All dimensions are referenced to the center of the solder pad. Refer to Figure 6 for the location of each module solder pad.

Table 3. Module Solder Pad Location

Solder Pad (Center of Pad)	Location (X,Y) from Origin (mm)	Dimension from Origin (mils)
1	(0.26, 3.37)	(10.24, 132.68)
2	(0.26, 4.13)	(10.24, 162.68)
3	(0.26, 4.89)	(10.24, 192.68)
4	(0.26, 5.66)	(10.24, 222.68)
5	(0.26, 6.42)	(10.24, 252.68)
6	(0.26, 7.18)	(10.24, 282.68)
7	(0.26, 7.94)	(10.24, 312.68)
8	(0.26, 8.70)	(10.24, 342.68)
9	(0.56, 15.14)	(22.05, 596.06)
10	(1.32, 15.14)	(51.97, 596.06)
11	(2.08, 15.14)	(81.89, 596.06)
12	(2.84, 15.14)	(111.81, 596.06)
13	(3.61, 15.14)	(142.13, 596.06)
14	(4.37, 15.14)	(172.13, 596.06)
15	(5.13, 15.14)	(202.13, 596.06)
16	(5.89, 15.14)	(231.89, 596.06)
17	(6.65, 15.14)	(261.81, 596.06)
18	(7.42, 15.14)	(292.13, 596.06)
19	(8.18, 15.14)	(322.05, 596.06)
20	(8.94, 15.14)	(351.97, 596.06)
21	(9.24, 14.04)	(363.78, 552.76)
22	(9.24, 13.28)	(363.78, 522.83)
23	(9.24, 12.51)	(363.78, 492.52)
24	(9.24, 11.75)	(363.78, 462.60)
25	(9.24, 10.99)	(363.78, 432.68)
26	(9.24, 10.23)	(363.78, 402.76)
27	(9.24, 9.47)	(363.78, 372.83)
28	(9.24, 8.70)	(363.78, 342.52)
29	(9.24, 7.94)	(363.78, 312.60)
30	(9.24, 7.18)	(363.78, 282.68)
31	(9.24, 6.42)	(363.78, 252.76)
32	(9.24, 5.66)	(363.78, 222.83)

Figure 6. Solder Pad Reference Location

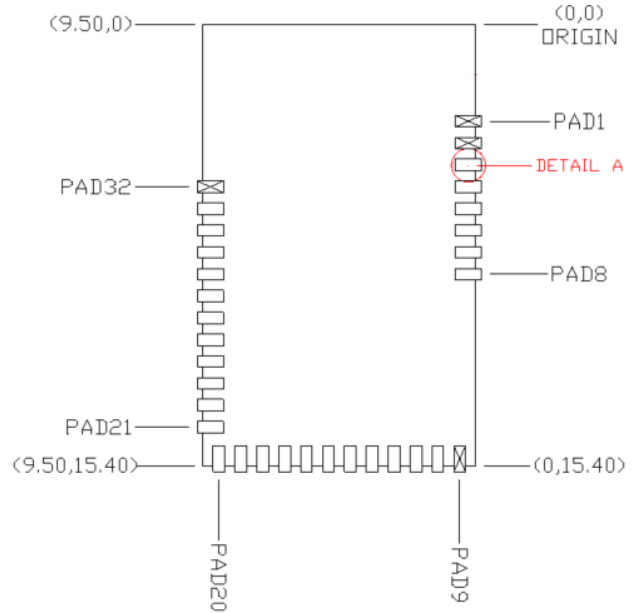

Top View (Seen on Host PCB)

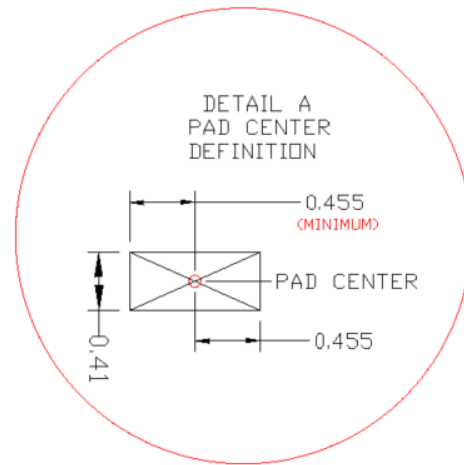

Digital and Analog Capabilities and Connections

Table 4 and Table 5 detail the solder pad connection definitions and available functions for each connection pad. Table 4 lists the solder pads on CYBLE-224116-01, the Bluetooth LE device port-pin, and denotes whether the digital function shown is available for each solder pad. Table 5 denotes whether the analog function shown is available for each solder pad. Each connection is configurable for a single option shown with a ✓.

Table 4. Digital Peripheral Capabilities

Pad Number	Device Port Pin	UART	SPI	I ² C	TCPWM ^[4,5]	Cap-Sense	WCO Out	ECO OUT	LCD	SWD	GPIO
1	GND ^[6]	Ground Connection									
2	XRES	External Reset Hardware Connection Input									
3	P1.5	✓(SCB0_TX)	✓(SCB0_MISO)	✓(SCB0_SCL)	✓(TCPWM)	✓			✓		✓
4	P1.1		✓(SCB1_SS1)		✓(TCPWM)	✓			✓		✓
5	P1.0				✓(TCPWM)	✓			✓		✓
6	P0.1	✓(SCB1_TX)	✓(SCB1_MISO)	✓(SCB1_SCL)	✓(TCPWM)	✓			✓		✓
7	P0.4	✓(SCB0_RX)	✓(SCB0_MOSI)	✓(SCB0_SDA)	✓(TCPWM)	✓		✓	✓		✓
8	P0.5	✓(SCB0_TX)	✓(SCB0_MISO)	✓(SCB0_SCL)	✓(TCPWM)	✓			✓		✓
9	P0.7	✓(SCB0_CTS)	✓(SCB0_SCLK)		✓(TCPWM)	✓			✓	✓ (SWDCLK)	✓
10	P1.3		✓(SCB1_SS3)		✓(TCPWM)	✓			✓		✓
11	V _{DDR}	Radio Power Supply (2.0 V to 3.6 V)									
12	P0.6	✓(SCB0_RTS)	✓(SCB0_SS0)		✓(TCPWM)	✓			✓	✓ (SWDIO)	✓
13	P1.2		✓(SCB1_SS2)		✓(TCPWM)	✓			✓		✓
14	V _{DD}	Digital Power Supply Input (2.0 V to 3.6 V)									
15	P1.4	✓(SCB0_RX)	✓(SCB0_MOSI)	✓(SCB0_SDA)	✓(TCPWM)	✓			✓		✓
16	P2.1		✓(SCB0_SS2)		✓(TCPWM)	✓			✓		✓
17	V _{DDA}	Analog Power Supply Input (2.0 V to 3.6 V)									
18	P2.2		✓(SCB0_SS3)		✓(TCPWM)	✓			✓		✓
19	P2.6				✓(TCPWM)	✓			✓		✓
20	P3.0	✓(SCB0_RX)		✓(SCB0_SDA)	✓(TCPWM)	✓			✓		✓
21	P2.3				✓(TCPWM)	✓	✓		✓		✓
22	V _{REF}	Reference Voltage Input									
23	P3.4	✓(SCB1_RX)		✓(SCB1_SDA)	✓(TCPWM)	✓			✓		✓
24	P3.5	✓(SCB1_TX)		✓(SCB1_SCL)	✓(TCPWM)	✓			✓		✓
25	P3.7	✓(SCB1_CTS)			✓(TCPWM)	✓	✓		✓		✓
26	P3.1	✓(SCB0_TX)		✓(SCB0_SCL)	✓(TCPWM)	✓			✓		✓
27	P3.6	✓(SCB1_RTS)			✓(TCPWM)	✓			✓		✓
28	P2.5				✓(TCPWM)	✓			✓		✓
29	P5.0	✓(SCB1_RX)	✓(SCB1_SS0)	✓(SCB1_SDA)	✓(TCPWM3_P)	✓			✓		✓
30	P5.1	✓(SCB1_TX)	✓(SCB1_SCLK)	✓(SCB1_SCL)	✓(TCPWM3_N)	✓		✓	✓		✓
31	P2.4				✓(TCPWM)	✓			✓		✓
32	GND ^[6]	Ground Connection									

Notes

- TCPWM stands for timer, counter, and PWM. If supported, the pad can be configured to any of these peripheral functions.
- TCPWM connections on ports 0, 1, 2, and 3 can be routed through the Digital Signal Interconnect (DSI) to any of the TCPWM blocks and can be either positive or negative polarity. TCPWM connections on port 5 are direct and can only be used with the specified TCPWM block and polarity specified above.
- The main board needs to connect both GND connections (Pad 1 and Pad 32) on the module to the common ground of the system.

Table 5. Analog Peripheral Capabilities

Pad Number	Device Port Pin	SARMUX	OPAMP	LPCOMP
1	GND ^[6]	Ground Connection		
2	XRES	External Reset Hardware Connection Input		
3	P1.5		✓(CTBm1_OA1_INP)	
4	P1.1		✓(CTBm1_OA0_INN)	
5	P1.0		✓(CTBm1_OA0_INP)	
6	P0.1			
7	P0.4			✓(COMP1_INP)
8	P0.5			✓(COMP1_INN)
9	P0.7			
10	P1.3		✓(CTBm1_OA1_OUT)	
11	V _{DDR}	Radio Power Supply (2.0 V to 3.6 V)		
12	P0.6			
13	P1.2		✓(CTBm1_OA0_OUT)	
14	V _{DD}	Digital Power Supply Input (2.0 V to 3.6 V)		
15	P1.4		✓(CTBm1_OA1_INN)	
16	P2.1		✓(CTBm0_OA0_INN)	
17	V _{DDA}	Analog Power Supply Input (2.0 V to 3.6 V)		
18	P2.2		✓(CTBm0_OA0_OUT)	
19	P2.6		✓(CTBm0_OA0_INP)	
20	P3.0	✓		
21	P2.3		✓(CTBm0_OA1_OUT)	
22	V _{REF}	Reference Voltage Input (Optional)		
23	P3.4	✓		
24	P3.5	✓		
25	P3.7	✓		
26	P3.1	✓		
27	P3.6	✓		
28	P2.5		✓(CTBm0_OA1_INP)	
29	P5.0			
30	P5.1			
31	P2.4		✓(CTBm0_OA1_INN)	
32	GND	Ground Connection		

Power Supply Connections and Recommended External Components

Power Connections

The CYBLE-224116-01 contains three power supply connections, VDD, VDDA, and VDDR. The VDD and VDDA connections supply power for the digital and analog device operation respectively. VDDR supplies power for the device radio and PA/LNA.

VDD, VDDA, and VDDR accept a supply range of 2.0 V to 3.6 V. These specifications can be found in Table 13. The maximum power supply ripple for both power connections on the module is 100 mV, as shown in Table 11.

The power supply ramp rate of VDD and VDDA must be equal to or greater than that of VDDR when the radio is used.

Connection Options

Two connection options are available for any application:

1. Single supply: Connect VDD, VDDA, and VDDR to the same supply.
2. Independent supply: Power VDD, VDDA, and VDDR separately.

External Component Recommendation

In either connection scenario, it is recommended to place an external ferrite bead between the supply and the module connection. The ferrite bead should be positioned as close as possible to the module pin connection.

Figure 7 details the recommended host schematic options for a single supply scenario. The use of one or three ferrite beads will depend on the specific application and configuration of the CYBLE-224116-01.

Figure 8 details the recommended host schematic for an independent supply scenario.

The recommended ferrite bead value is 330 Ω, 100 MHz. (Murata BLM21PG331SN1D).

Figure 7. Recommended Host Schematic Options for a Single Supply Option

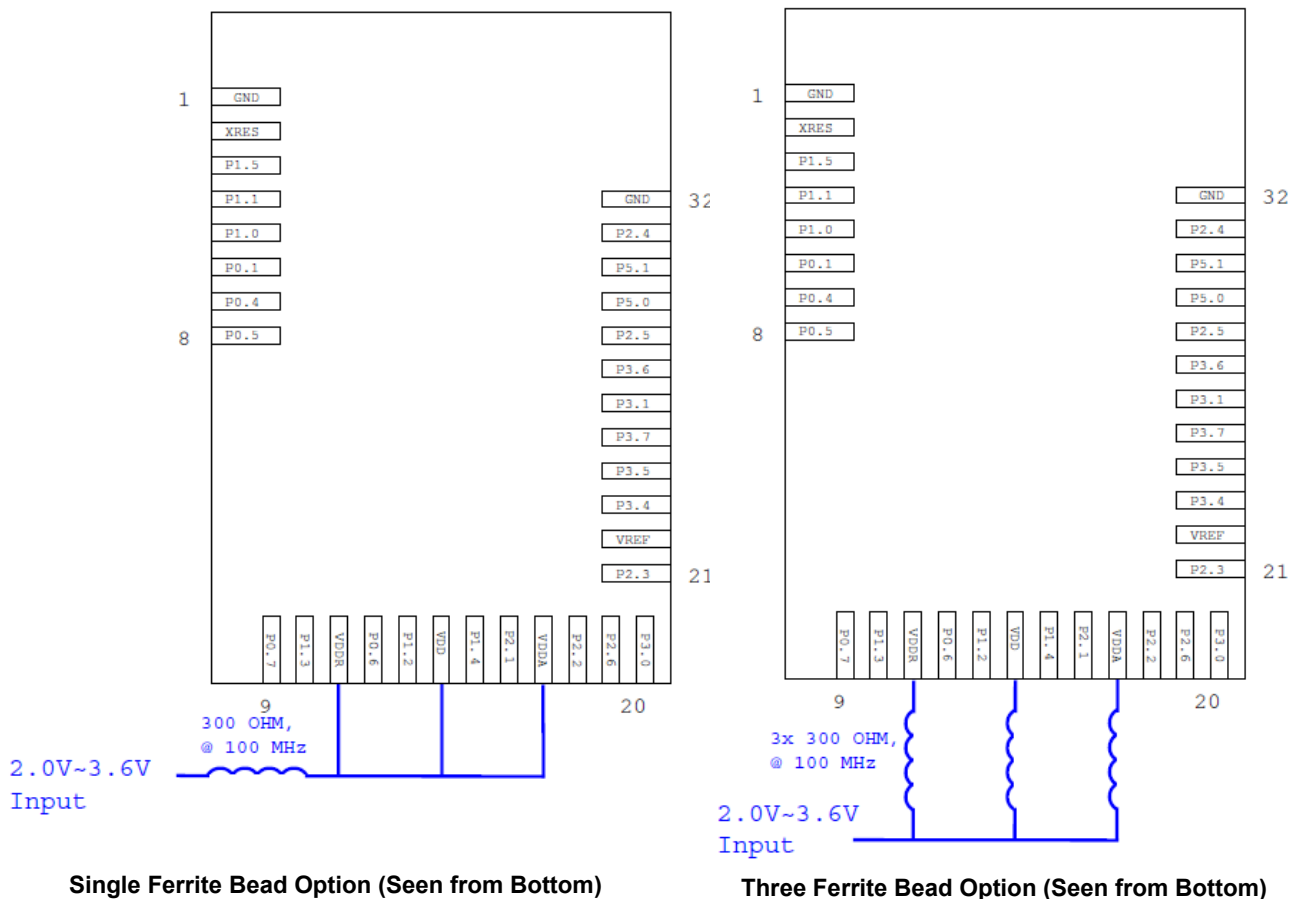
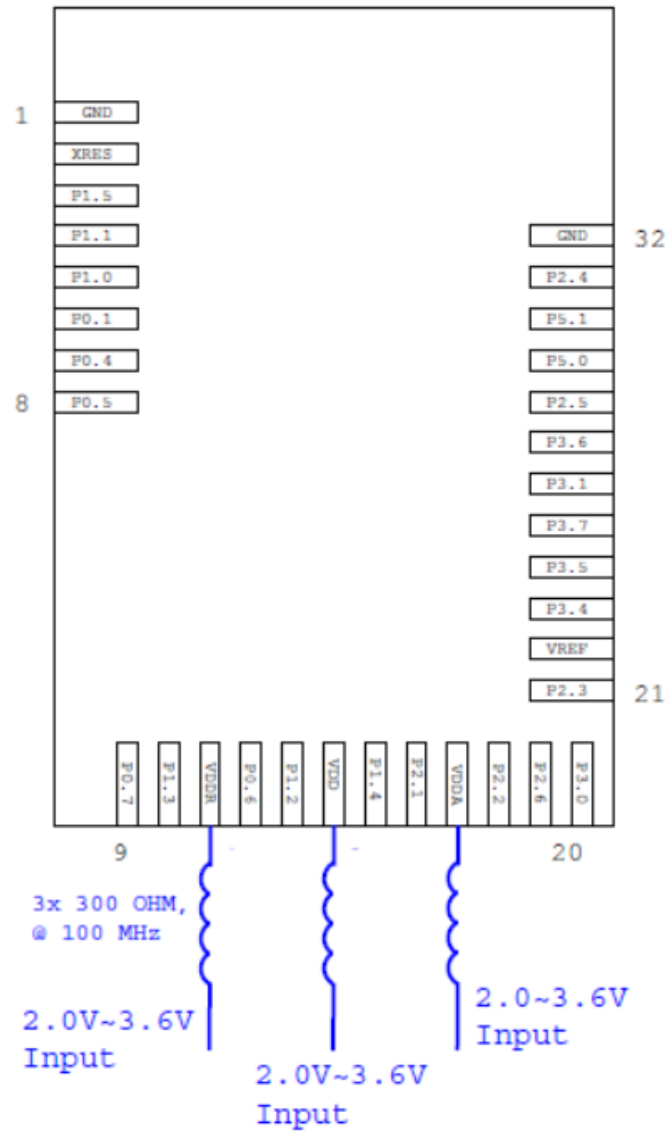

Figure 8. Recommended Host Schematic for an Independent Supply Option



Independent Power Supply Option (Seen from Bottom)

The CYBLE-224116-01 schematic is shown in Figure 9.

Figure 9. CYBLE-224116-01 Schematic Diagram

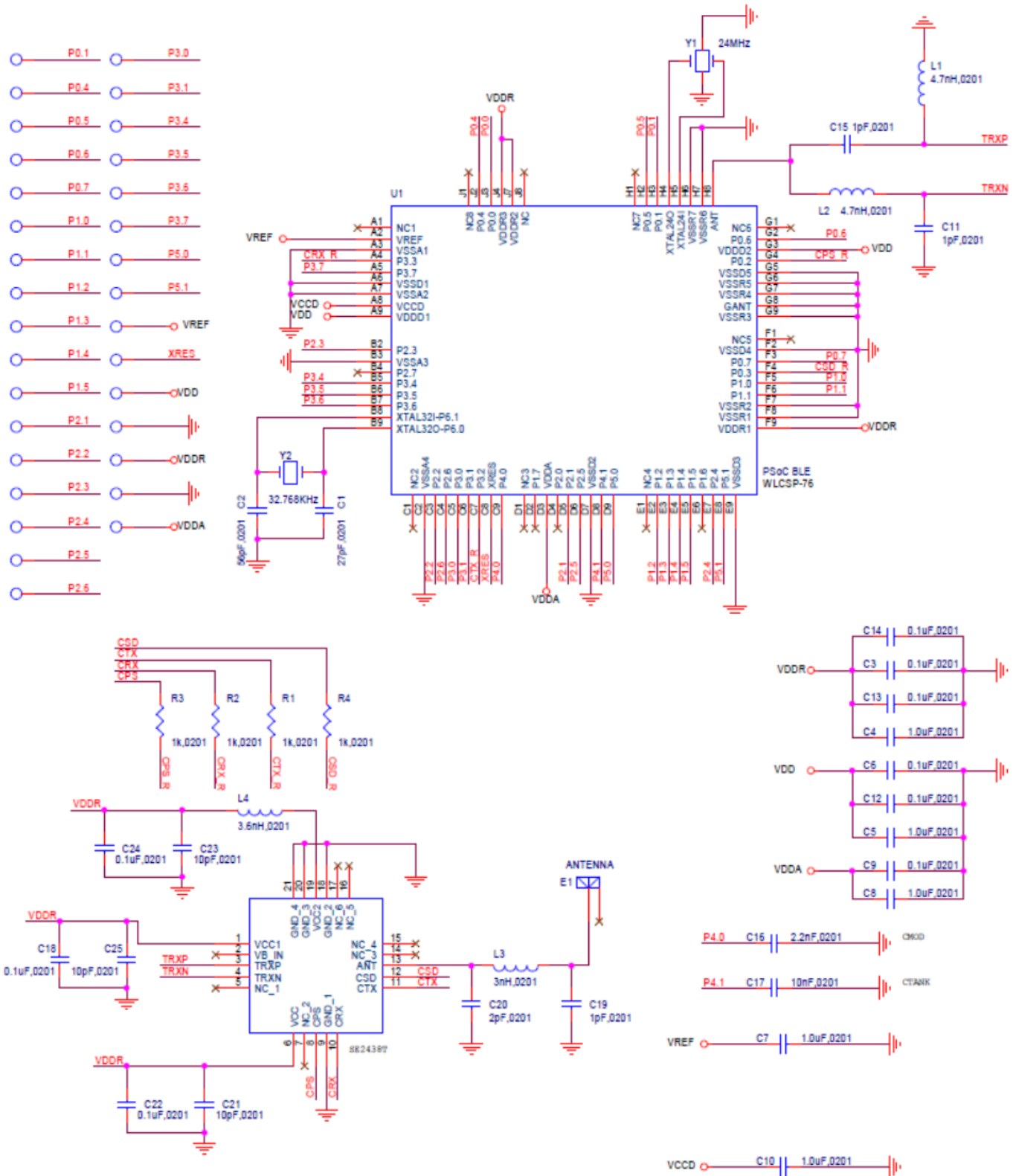

Critical Components List

Table 6 details the critical components used in the CYBLE-224116-01 module.

Table 6. Critical Component List

Component	Reference Designator	Description
Silicon	U1	76-pin WLCSP Programmable System-on-Chip (PSoC) with Bluetooth LE
Crystal	Y1	24.000 MHz, 10PF
Crystal	Y2	32.768 kHz, 12.5PF

Antenna Design

Table 7 details the antenna used on the CYBLE-224116-01 module. The Cypress module performance improves many of these characteristics. For more information, see Table 12.

Table 7. Chip Antenna Specifications

Item	Description
Chip Antenna Manufacturer	Johanson Technology Inc.
Chip Antenna Part Number	2450AT18B100
Frequency Range	2400 – 2500 MHz
Peak Gain	0.5-dBi typical
Average Gain	-0.5-dBi typical
Return Loss	9.5-dB minimum

Power Amplifier (PA) and Low Noise Amplifier (LNA)

Table 8 details the PA/LNA that is used on the CYBLE-224116-01 module. For more information, see Table 12.

Table 8. Power Amplifier/Low Noise Amplifier Details

Item	Description
PA/LNA Manufacturer	Skyworks Inc.
PA/LNA Part Number	SE2438T
Power Supply Range	2.0 V ~ 3.6 V

Table 9 details the power consumption of the integrated PA/LNA used on the CYBLE-224116-01 module. Table 9 only details the current consumption of the SE2438T PA/LNA. $V_{CC} = V_{CC1} = V_{CC2} = 3\text{ V}$, $T_A = +25\text{ }^\circ\text{C}$, measured on the SE2438T evaluation board, unless otherwise noted.

Table 9. Power Amplifier/Low Noise Amplifier Current Consumption Specifications

Parameter	Symbol	Test Condition	Min	Typ	Max	Units
Total supply current	I_{CC_Tx14}	Tx mode $P_{OUT} = +14\text{ dBm}$	–	33	–	mA
Total supply current	I_{CC_Tx12}	Tx mode $P_{OUT} = +12\text{ dBm}$	–	25	–	mA
Total supply current	I_{CC_Tx10}	Tx mode $P_{OUT} = +10\text{ dBm}$	–	20	–	mA
Quiescent current	I_{CC_Tx}	No RF	–	6	–	mA
Total supply current	I_{CC_RXHG}	Rx Low Noise Amplifier (LNA) High Gain mode	–	5.5	–	mA
Total supply current	I_{CC_RXLG}	Rx LNA Low Gain mode	–	2.7	–	mA
Total supply current	$I_{CC_RXBypass}$	Rx Bypass mode	–	–	10	μA
Sleep supply current	I_{CC_OFF}	No RF	–	0.05	1.0	μA

Enabling Extended Range Feature

The CYBLE-224116-01 module comes with an integrated Power Amplifier/Low Noise Amplifier to allow for extended communication range of up to 400 meters full line-of-sight. This section describes the firmware steps required to enable extended range operation of the CYBLE-224116-01 module. For detailed step-by-step instructions, refer to the [Getting Started with EZ-BLE Module Application Note](#), Appendix B.2.3.2.

The PA/LNA integrated on the CYBLE-224116-01 module must be configured properly in order for the module to function as intended. In cases which require radio transmission without extended range functionality, the PA/LNA must be set to Bypass mode in order to ensure that the RF signal reaches the antenna. If the PA/LNA is disabled instead, the antenna will be unable to radiate any signal. Refer to [Table 10](#) for the correct CSD and CPS configurations for PA/LNA Bypass mode.

The Skyworks SE2438T PA/LNA is controlled by PSoC4 Bluetooth LE and uses four pins:

1. Two pins for the radio enable (CPS - P0[2], CSD - P0[3]). The CPS and CSD pins are controlled in the firmware application code of the CYBLE-224116-01.
2. One pin to control the PA enable (P3[2]). The PA enable pin is controlled directly by the Bluetooth LE Link Layer.
3. One pin to control the LNA enable (P3[3]). The LNA enable pin is controlled directly by the Bluetooth LE Link Layer.
4. Ensure that the PSoC[®] 4 Bluetooth LE silicon device “Adv/Scan TX Power Level (dBm)” and “Connection TX Power Level (dBm)” in the Bluetooth LE component are both set to -6 dBm^[7].

To enable the extended range functionality, follow the steps outlined below.

1. Drag and drop two “Digital Output Pin” components from the Component Catalog to the schematic page in PSoC Creator
2. Double-click the pins and rename them as CPS and CSD. The HW connection option in the component configuration should be unchecked as these are Firmware GPIOs.
3. To configure the CPS and CSD pins, open your project's Design-Wide Resources file (for example, “Project_Name.cydwr”) from your Workspace Explorer and click the “Pins” tab. The “Pins” tab is used to select the physical device connections for the outputs (CPS, CSD). These pins are connected to the enable pins of the Skyworks SE2438T Power Amplifier. In order for extended range operation to function, it is required to configure the CPS and CSD pins to P0[2] and P0[3] respectively.
4. Open your project's main.c file and write the below code to define the register at the top of the code.

```
/* define the test register to switch the PA/LNA hardware control pins */
#define CYREG_SRSS_TST_DDFT_CTRL 0x40030008
```

5. Locate/add the event “CYBLE_EVT_STACK_ON” in the application code and insert the below four lines of code to enable the Skyworks SE2438T.

```
/* Mandatory events to be handled by BLE application code */
case CYBLE_EVT_STACK_ON:
/* Enable the Skyworks SE2438T PA/LNA */
    CSD_Write(1);
    CPS_Write(1);

/* Configure the Link Layer to automatically switch PA control pin P3[2] and LNA control pin P3[3] */
    CY_SET_XTND_REG32((void CYFAR *) (CYREG_BLE_BLESS_RF_CONFIG), 0x0331);
    CY_SET_XTND_REG32((void CYFAR *) (CYREG_SRSS_TST_DDFT_CTRL), 0x80000302);
```

Note

7. The CYBLE-224116-01 module is certified for FCC, IC, CE, MIC and KC regulations at an output power of +9.5 dBm. To achieve this output power, RF_{O2} (PSoC 4 Bluetooth LE silicon PA level) must be set to the -6 dBm setting in firmware. Settings higher than this will result in higher output power than specified in the CYBLE-224116-01 certifications.

Power Saving Measures with PA/LNA Operation

The section will describe power saving measures available for controlling the integrated PA/LNA on the CYBLE-224116-01 module. [Table 10](#) lists the states available through via the CSD and CPS logic control signals.

Table 10. PA/LNA Logic Controls and Power Modes

PA/LNA Mode	CSD (P0[3]) Logic State	CPS (P0[2]) Logic State	Description
0	0	0	All Off. Lowest Power Mode PA and LNA are off
1	0	1	Standby Mode Recommended mode for low power operation
2	1	0	TX and RX Bypass Mode
3	1	1	High Power TX and High Gain RX

Power Optimization Tips with Extended Range Functionality

If left in High Power TX and High Gain RX mode continuously, the integrated PA/LNA on the CYBLE-224116-01 module will draw more current than may be desired. Optimizing the average power consumption of the CYBLE-224116-01 module can be accomplished via the CSD and CPS logic control signals explained in [Enabling Extended Range Feature](#) and shown in [Table 10](#).

To minimize power consumption of a Bluetooth LE solution that is utilizing the extended range feature of the CYBLE-224116-01, the PA/LNA should be set to either Mode 0 (All Off) or Mode 1 (Standby). Transitioning the PA/LNA from Mode 3 (High Power and High Gain) to either Mode 0 or 1 needs to be taken care of in the application firmware. The recommendations below should be followed when changing modes of the PA/LNA on the CYBLE-224116-01 module.

1. To set the PA/LNA to a low power mode, either Power Mode 0 or Power Mode 1 should be entered just before the Bluetooth LE application firmware transitions the PSoC[®] 4 Bluetooth LE silicon device to a Sleep or Deep Sleep mode. To execute the transition of the PA/LNA to a lower power mode, the below code should be used in the low power routine in the application firmware. Power Mode 0 and Power Mode 1 PA/LNA commands are both shown.

```
/* Set the Skyworks SE2438T PA/LNA to Power Mode 0 (All Off)*/
CSD_Write(0);
CPS_Write(0);
```

```
/* Set the Skyworks SE2438T PA/LNA to Power Mode 1 (Standby)*/
CSD_Write(0);
CPS_Write(1);
```

2. When the Bluetooth LE system is transitioning to Active mode (i.e. waking from low power mode) and extended range functionality is required, it is necessary to enable the PA/LNA to Power Mode 3. Enabling the PA/LNA should be the first action completed during when transitioning the PSoC[®] 4 Bluetooth LE silicon device from a low power mode to active mode. Enabling the PA/LNA to Power Mode 3 can be completed using the following commands in the wakeup routine of the application firmware.

```
/* Set the Skyworks SE2438T PA/LNA to Power Mode 3 (High Power and High Gain)*/
CSD_Write(1);
CPS_Write(1);
```

3. Power Mode 2 (TX/RX Bypass) is not recommended for typical low power mode use. Bypass mode should be considered if a transition from Extended Range functionality to short-range communication is desired on-the-fly. Transitions from Active mode to Bypass mode are only recommended after a Bluetooth LE event has completed and no RF activity is in process.

Electrical Specifications

Table 11 details the absolute maximum electrical characteristics for the Cypress Bluetooth LE module.

Table 11. CYBLE-224116-01 Absolute Maximum Ratings

Parameter	Description	Min	Typ	Max	Units	Details/Conditions
V _{DD_ABS}	V _{DD} , V _{DDA} and V _{DDR} supply relative to V _{SS} (V _{SSD} = V _{SSA})	-0.3	–	3.6	V	Restricted by SE2438T
V _{CCD_ABS}	Direct digital core voltage input relative to V _{SSD}	-0.5	–	1.95	V	Absolute maximum
V _{DD_RIPPLE}	Maximum power supply ripple for V _{DD} , V _{DDA} and V _{DDR} input voltage	–	–	100	mV	3.0-V supply Ripple frequency of 100 kHz to 750 kHz
V _{GPIO_ABS}	GPIO voltage	-0.5	–	V _{DD} + 0.5	V	Absolute maximum
I _{GPIO_ABS}	Maximum current per GPIO	-25	–	25	mA	Absolute maximum
I _{GPIO_injection}	GPIO injection current: Maximum for V _{IH} > V _{DD} and minimum for V _{IL} < V _{SS}	-0.5	–	0.5	mA	Absolute maximum current injected per pin
LU	Pin current for latch up	-200		200	mA	–

Table 12 details the RF characteristics for the Cypress Bluetooth LE module.

Table 12. CYBLE-224116-01 RF Performance Characteristics

Parameter	Description	Min	Typ	Max	Units	Details/Conditions
RF _{O1} ^[8]	RF output power on ANT PA active	-3.5	0	9.5	dBm	Configurable via register settings. PA active. RF _{O2} = -6 dBm PA/LNA active.
RF _{O2}	RF output power on ANT PA bypassed	-18	0	3	dBm	PSoC 4 Bluetooth LE Silicon. Configurable via register settings. PA in bypass mode.
RX _{S1}	RF receive sensitivity on ANT LNA active	–	-95	–	dBm	Measured value
RX _{S2}	RF receive sensitivity on ANT LNA bypassed	–	-87	–	dBm	Measured value
F _R	Module frequency range	2402	–	2480	MHz	–
G _P	Peak gain	–	0.5	–	dBi	–
RL	Return loss	–	-10	–	dB	–

Note

- The CYBLE-224116-01 module is certified for FCC, ISED, CE, MIC, and KC regulations at an output power of +9.5 dBm. To achieve this output power, RF_{O2} must be set to the -6 dBm setting in firmware. Settings higher than this will result in higher output power than specified in the CYBLE-224116-01 certifications.

Table 13 through Table 55 list the module-level electrical characteristics for the CYBLE-224116-01. All specifications are valid for $-40\text{ }^{\circ}\text{C} \leq T_A \leq 105\text{ }^{\circ}\text{C}$, except where noted. Specifications are valid for 2.0 V to 3.6 V, except where noted.

Table 13. CYBLE-224116-01 DC Specifications

Parameter	Description	Min	Typ	Max	Units	Details/Conditions
V_{DD}	Power supply input voltage (V_{DD} , V_{DDA} , V_{DDR})	2.0	–	3.6	V	Restricted by SE2438T $V_{DDR} \leq V_{DD}$
Active Mode, $V_{DD} = 2.0\text{ V to }3.6\text{ V}$						
I_{DD3}	Execute from flash; CPU at 3 MHz	–	1.7	–	mA	$T = 25\text{ }^{\circ}\text{C}$, $V_{DD} = 3.3\text{ V}$
I_{DD4}	Execute from flash; CPU at 3 MHz	–	–	–	mA	$T = -40\text{ }^{\circ}\text{C to }105\text{ }^{\circ}\text{C}$
I_{DD5}	Execute from flash; CPU at 6 MHz	–	2.5	–	mA	$T = 25\text{ }^{\circ}\text{C}$, $V_{DD} = 3.3\text{ V}$
I_{DD6}	Execute from flash; CPU at 6 MHz	–	–	–	mA	$T = -40\text{ }^{\circ}\text{C to }105\text{ }^{\circ}\text{C}$
I_{DD7}	Execute from flash; CPU at 12 MHz	–	4	–	mA	$T = 25\text{ }^{\circ}\text{C}$, $V_{DD} = 3.3\text{ V}$
I_{DD8}	Execute from flash; CPU at 12 MHz	–	–	–	mA	$T = -40\text{ }^{\circ}\text{C to }105\text{ }^{\circ}\text{C}$
I_{DD9}	Execute from flash; CPU at 24 MHz	–	7.1	–	mA	$T = 25\text{ }^{\circ}\text{C}$, $V_{DD} = 3.3\text{ V}$
I_{DD10}	Execute from flash; CPU at 24 MHz	–	–	–	mA	$T = -40\text{ }^{\circ}\text{C to }105\text{ }^{\circ}\text{C}$
I_{DD11}	Execute from flash; CPU at 48 MHz	–	13.4	–	mA	$T = 25\text{ }^{\circ}\text{C}$, $V_{DD} = 3.3\text{ V}$
I_{DD12}	Execute from flash; CPU at 48 MHz	–	–	–	mA	$T = -40\text{ }^{\circ}\text{C to }105\text{ }^{\circ}\text{C}$
Sleep Mode, V_{DD} and $V_{DDR} = 2.0\text{ V to }3.6\text{ V}$, PA/LNA in All Off mode						
I_{DD13}	IMO on	–	–	–	mA	$T = 25\text{ }^{\circ}\text{C}$, $V_{DD} = 3.3\text{ V}$, SYSCLK = 3 MHz
Sleep Mode, V_{DD} and $V_{DDR} = 2.0\text{ V to }3.6\text{ V}$, PA/LNA in All Off mode						
I_{DD14}	ECO on	–	–	–	mA	$T = 25\text{ }^{\circ}\text{C}$, $V_{DD} = 3.3\text{ V}$, SYSCLK = 3 MHz
Deep-Sleep Mode, V_{DD} and $V_{DDR} = 2.0\text{ V to }3.6\text{ V}$, PA/LNA in All Off mode						
I_{DD15}	WDT with WCO on	–	2.3	–	μA	$T = 25\text{ }^{\circ}\text{C}$, $V_{DD} = 3.3\text{ V}$
I_{DD16}	WDT with WCO on	–	–	–	μA	$T = -40\text{ }^{\circ}\text{C to }105\text{ }^{\circ}\text{C}$
I_{DD18}	WDT with WCO on	–	–	–	μA	$T = -40\text{ }^{\circ}\text{C to }105\text{ }^{\circ}\text{C}$
Hibernate Mode, V_{DD} and $V_{DDR} = 2.0\text{ V to }3.6\text{ V}$, PA/LNA in All Off mode						
I_{DD27}	GPIO and reset active	–	150	–	nA	$T = 25\text{ }^{\circ}\text{C}$, $V_{DD} = 3.3\text{ V}$
I_{DD28}	GPIO and reset active	–	–	–	nA	$T = -40\text{ }^{\circ}\text{C to }105\text{ }^{\circ}\text{C}$
Stop Mode, $V_{DD} = V_{DDR} = 2.0\text{ V to }3.6\text{ V}$, PA/LNA in All Off						
I_{DD33}	Stop-mode current (V_{DD})	–	20	–	nA	$T = 25\text{ }^{\circ}\text{C}$, $V_{DD} = 3.3\text{ V}$
I_{DD34}	Stop-mode current (V_{DDR})	–	540	–	nA	$T = 25\text{ }^{\circ}\text{C}$, $V_{DDR} = 3.3\text{ V}$
I_{DD35}	Stop-mode current (V_{DD})	–	–	–	nA	$T = -40\text{ }^{\circ}\text{C to }105\text{ }^{\circ}\text{C}$
I_{DD36}	Stop-mode current (V_{DDR})	–	–	–	nA	$T = -40\text{ }^{\circ}\text{C to }105\text{ }^{\circ}\text{C}$, $V_{DDR} = 2.0\text{ V to }3.6\text{ V}$

Table 14. AC Specifications

Parameter	Description	Min	Typ	Max	Units	Details/Conditions
F _{CPU}	CPU frequency	DC	–	48	MHz	2.0 V ≤ V _{DD} ≤ 3.6 V
T _{SLEEP}	Wakeup from Sleep mode	–	0	–	μs	Guaranteed by characterization
T _{DEEPSLEEP}	Wakeup from Deep-Sleep mode	–	–	25	μs	24-MHz IMO. Guaranteed by characterization
T _{HIBERNATE}	Wakeup from Hibernate mode	–	–	2	ms	Guaranteed by characterization
T _{STOP}	Wakeup from Stop mode	–	–	2	ms	Guaranteed by characterization

GPIO
Table 15. GPIO DC Specifications

Parameter	Description	Min	Typ	Max	Units	Details/Conditions
V _{IH} ^[9]	Input voltage HIGH threshold	0.7 × V _{DD}	–	–	V	CMOS input
	LVTTL input, 2.0 V ≤ V _{DD} < 2.7 V	0.7 × V _{DD}	–	–	V	–
	LVTTL input, 2.7 V ≤ V _{DD} ≤ 3.6 V	2.0	–	–	V	–
V _{IL}	Input voltage LOW threshold	–	–	0.3 × V _{DD}	V	CMOS input
	LVTTL input, 2.0 V ≤ V _{DD} < 2.7 V	–	–	0.3 × V _{DD}	V	–
	LVTTL input, 2.7 V ≤ V _{DD} ≤ 3.6 V	–	–	0.8	V	–
V _{OH}	Output voltage HIGH level	V _{DD} – 0.6	–	–	V	I _{OH} = 4 mA at 3.3-V V _{DD}
V _{OL}	Output voltage LOW level	–	–	0.6	V	I _{OL} = 8 mA at 3.3-V V _{DD}
R _{PULLUP}	Pull-up resistor	3.5	5.6	8.5	kΩ	–
R _{PULLDOWN}	Pull-down resistor	3.5	5.6	8.5	kΩ	–
I _{IL}	Input leakage current (absolute value)	–	–	2	nA	25 °C, V _{DD} = 3.3 V
I _{IL_CTBM}	Input leakage on CTBm input pins	–	–	4	nA	–
C _{IN}	Input capacitance	–	–	7	pF	–
V _{HYSTTL}	Input hysteresis LVTTL	25	40	–	mV	2.7 V ≤ V _{DD} ≤ 3.6 V
V _{HYSMOS}	Input hysteresis CMOS	0.05 × V _{DD}	–	–	1	–
I _{DIODE}	Current through protection diode to V _{DD} /V _{SS}	–	–	100	μA	–
I _{TOT_GPIO}	Maximum total source or sink chip current	–	–	200	mA	–

Note

9. V_{IH} must not exceed V_{DD} + 0.2 V.

Table 16. GPIO AC Specifications

Parameter	Description	Min	Typ	Max	Units	Details/Conditions
T _{RISEF}	Rise time in Fast-Strong mode	2	–	12	ns	3.3-V V _{DD} , C _{LOAD} = 25 pF
T _{FALLF}	Fall time in Fast-Strong mode	2	–	12	ns	3.3-V V _{DD} , C _{LOAD} = 25 pF
T _{RISES}	Rise time in Slow-Strong mode	10	–	60	ns	3.3-V V _{DD} , C _{LOAD} = 25 pF
T _{FALLS}	Fall time in Slow-Strong mode	10	–	60	ns	3.3-V V _{DD} , C _{LOAD} = 25 pF
F _{GPIOUT1}	GPIO F _{OUT} ; 3.3 V ≤ V _{DD} ≤ 3.6 V Fast-Strong mode	–	–	33	MHz	90/10%, 25-pF load, 60/40 duty cycle
F _{GPIOUT2}	GPIO F _{OUT} ; 2.0 V ≤ V _{DD} ≤ 3.3 V Fast-Strong mode	–	–	16.7	MHz	90/10%, 25-pF load, 60/40 duty cycle
F _{GPIOUT3}	GPIO F _{OUT} ; 3.3 V ≤ V _{DD} ≤ 3.6 V Slow-Strong mode	–	–	7	MHz	90/10%, 25-pF load, 60/40 duty cycle
F _{GPIOUT4}	GPIO F _{OUT} ; 2.0 V ≤ V _{DD} ≤ 3.3 V Slow-Strong mode	–	–	3.5	MHz	90/10%, 25-pF load, 60/40 duty cycle
F _{GPIOIN}	GPIO input operating frequency 2.0 V ≤ V _{DD} ≤ 3.6 V	–	–	48	MHz	90/10% V _{IO}

Table 17. OVT GPIO DC Specifications (P5_0 and P5_1 Only)

Parameter	Description	Min	Typ	Max	Units	Details/Conditions
I _{IL}	Input leakage (absolute value). V _{IH} > V _{DD}	–	–	10	μA	25°C, V _{DD} = 0 V, V _{IH} = 3.0 V
V _{OL}	Output voltage LOW level	–	–	0.4	V	I _{OL} = 20 mA, V _{DD} > 2.9 V

Table 18. OVT GPIO AC Specifications (P5_0 and P5_1 Only)

Parameter	Description	Min	Typ	Max	Units	Details/Conditions
T _{RISE_OVFS}	Output rise time in Fast-Strong mode	1.5	–	12	ns	25-pF load, 10%–90%, V _{DD} =3.3 V
T _{FALL_OVFS}	Output fall time in Fast-Strong mode	1.5	–	12	ns	25-pF load, 10%–90%, V _{DD} =3.3 V
T _{RISESS}	Output rise time in Slow-Strong mode	10	–	60	ns	25-pF load, 10%-90%, V _{DD} = 3.3 V
T _{FALLSS}	Output fall time in Slow-Strong mode	10	–	60	ns	25-pF load, 10%-90%, V _{DD} = 3.3 V
F _{GPIOUT1}	GPIO F _{OUT} ; 3.3 V ≤ V _{DD} ≤ 3.6 V Fast-Strong mode	–	–	24	MHz	90/10%, 25-pF load, 60/40 duty cycle
F _{GPIOUT2}	GPIO F _{OUT} ; 2.0 V ≤ V _{DD} ≤ 3.3 V Fast-Strong mode	–	–	16	MHz	90/10%, 25-pF load, 60/40 duty cycle

XRES
Table 19. XRES DC Specifications

Parameter	Description	Min	Typ	Max	Units	Details/Conditions
V _{IH}	Input voltage HIGH threshold	0.7 × V _{DD}	–	–	V	CMOS input
V _{IL}	Input voltage LOW threshold	–	–	0.3 × V _{DD}	V	CMOS input
R _{PULLUP}	Pull-up resistor	3.5	5.6	8.5	kΩ	–
C _{IN}	Input capacitance	–	3	–	pF	–
V _{HYSXRES}	Input voltage hysteresis	–	100	–	mV	–
I _{DIODE}	Current through protection diode to V _{DD} /V _{SS}	–	–	100	μA	–

Table 20. XRES AC Specifications

Parameter	Description	Min	Typ	Max	Units	Details/Conditions
T _{RESETWIDTH}	Reset pulse width	1	–	–	μs	–

Analog Peripherals
Opamp
Table 21. Opamp Specifications

Parameter	Description	Min	Typ	Max	Units	Details/Conditions
I_{DD} (Opamp Block Current. V_{DD} = 2.0 V. No Load)						
I _{DD_HI}	Power = high	–	1000	1300	μA	
I _{DD_MED}	Power = medium	–	500	–	μA	
I _{DD_LOW}	Power = low	–	250	350	μA	
GBW (Load = 20 pF, 0.1 mA. V_{DDA} = 2.7 V)						
GBW_HI	Power = high	6	–	–	MHz	
GBW_MED	Power = medium	4	–	–	MHz	
GBW_LO	Power = low	–	1	–	MHz	
I_{OUT_MAX} (V_{DDA} ≥ 2.7 V, 500 mV from Rail)						
I _{OUT_MAX_HI}	Power = high	10	–	–	mA	
I _{OUT_MAX_MID}	Power = medium	10	–	–	mA	
I _{OUT_MAX_LO}	Power = low	–	5	–	mA	
V_{OUT} (V_{DDA} ≥ 2.7 V)						
V _{OUT_1}	Power = high, I _{LOAD} =10 mA	0.5	–	V _{DDA} – 0.5	V	
V _{OUT_2}	Power = high, I _{LOAD} =1 mA	0.2	–	V _{DDA} – 0.2	V	
V _{OUT_3}	Power = medium, I _{LOAD} =1 mA	0.2	–	V _{DDA} – 0.2	V	
V _{OUT_4}	Power = low, I _{LOAD} =0.1 mA	0.2	–	V _{DDA} – 0.2	V	
V _{OS_TR}	Offset voltage, trimmed	1	±0.5	1	mV	High mode
V _{OS_TR}	Offset voltage, trimmed	–	±1	–	mV	Medium mode
V _{OS_TR}	Offset voltage, trimmed	–	±2	–	mV	Low mode
V _{OS_DR_TR}	Offset voltage drift, trimmed	–10	±3	10	μV/°C	High mode
V _{OS_DR_TR}	Offset voltage drift, trimmed	–	±10	–	μV/°C	Medium mode
V _{OS_DR_TR}	Offset voltage drift, trimmed	–	±10	–	μV/°C	Low mode
CMRR	DC	65	70	–	dB	V _{DD} = 3.6 V, High-power mode
PSRR	At 1 kHz, 100-mV ripple	70	85	–	dB	V _{DD} = 3.6 V

Table 21. Opamp Specifications (continued)

Parameter	Description	Min	Typ	Max	Units	Details/Conditions
Noise						
V _{N1}	Input referred, 1 Hz–1 GHz, power = high	–	94	–	μVrms	
V _{N2}	Input referred, 1 kHz, power = high	–	72	–	nV/rtHz	
V _{N3}	Input referred, 10 kHz, power = high	–	28	–	nV/rtHz	
V _{N4}	Input referred, 100 kHz, power = high	–	15	–	nV/rtHz	
C _{LOAD}	Stable up to maximum load. Performance specs at 50 pF	–	–	125	pF	
Slew_rate	Cl _{oad} = 50 pF, Power = High, V _{DDA} ≥ 2.7 V	6	–	–	V/μs	
T _{op_wake}	From disable to enable, no external RC dominating	–	300	–	μs	
Comp_mode (Comparator Mode; 50-mV Drive, T_{RISE} = T_{FALL} (Approx.))						
T _{PD1}	Response time; power = high	–	150	–	ns	
T _{PD2}	Response time; power = medium	–	400	–	ns	
T _{PD3}	Response time; power = low	–	2000	–	ns	
V _{hyst_op}	Hysteresis	–	10	–	mV	
Deep-Sleep Mode (Deep-Sleep mode operation is only guaranteed for V_{DDA} > 2.5 V)						
GBW_DS	Gain bandwidth product	–	50	–	kHz	
IDD_DS	Current	–	15	–	μA	
V _{os_DS}	Offset voltage	–	5	–	mV	
V _{os_dr_DS}	Offset voltage drift	–	20	–	μV/°C	
V _{out_DS}	Output voltage	0.2	–	V _{DD} –0.2	V	
V _{cm_DS}	Common mode voltage	0.2	–	V _{DD} –1.8	V	

Table 22. Comparator DC Specifications

Parameter	Description	Min	Typ	Max	Units	Details/Conditions
V _{OFFSET1}	Input offset voltage, Factory trim	–	–	±10	mV	
V _{OFFSET2}	Input offset voltage, Custom trim	–	–	±6	mV	
V _{OFFSET3}	Input offset voltage, ultra-low-power mode	–	±12	–	mV	
V _{HYST}	Hysteresis when enabled	–	10	35	mV	
V _{ICM1}	Input common mode voltage in normal mode	0	–	V _{DD} –0.1	V	Modes 1 and 2
V _{ICM2}	Input common mode voltage in low-power mode	0	–	V _{DD}	V	
V _{ICM3}	Input common mode voltage in ultra low-power mode	0	–	V _{DD} –1.15	V	
CMRR	Common mode rejection ratio	50	–	–	dB	V _{DD} ≥ 2.7 V
CMRR	Common mode rejection ratio	42	–	–	dB	V _{DD} ≤ 2.7 V
I _{CMP1}	Block current, normal mode	–	–	400	μA	
I _{CMP2}	Block current, low-power mode	–	–	100	μA	
I _{CMP3}	Block current in ultra-low-power mode	–	6	–	μA	
Z _{CMP}	DC input impedance of comparator	35	–	–	MΩ	

Table 23. Comparator AC Specifications

Parameter	Description	Min	Typ	Max	Units	Details/Conditions
T _{RESP1}	Response time, normal mode, 50-mV overdrive	–	38	–	ns	50-mV overdrive
T _{RESP2}	Response time, low-power mode, 50-mV overdrive	–	70	–	ns	50-mV overdrive
T _{RESP3}	Response time, ultra-low-power mode, 50-mV overdrive	–	2.3	–	μs	200-mV overdrive V _{DD} ≥ 2.6 V for Temp < 0 °C V _{DD} ≥ 2.0 V for Temp < 0 °C

Temperature Sensor
Table 24. Temperature Sensor Specifications

Parameter	Description	Min	Typ	Max	Units	Details/Conditions
T _{SENSACC}	Temperature-sensor accuracy	–5	±1	5	°C	–40 to +85 °C

SAR ADC
Table 25. SAR ADC DC Specifications

Parameter	Description	Min	Typ	Max	Units	Details/Conditions
A_RES	Resolution	–	–	12	bits	
A_CHNIS_S	Number of channels - single-ended	–	–	8		8 full-speed ^[10]
A-CHNKS_D	Number of channels - differential	–	–	4		Diff inputs use neighboring I/O ^[10]
A-MONO	Monotonicity	–	–	–		Yes
A_GAINERR	Gain error	–	–	±0.1	%	With external reference
A_OFFSET	Input offset voltage	–	–	2	mV	Measured with 1-V V _{REF}
A_ISAR	Current consumption	–	–	1	mA	
A_VINS	Input voltage range - single-ended	V _{SS}	–	V _{DDA}	V	
A_VIND	Input voltage range - differential	V _{SS}	–	V _{DDA}	V	
A_INRES	Input resistance	–	–	2.2	kΩ	
A_INCAP	Input capacitance	–	–	10	pF	
VREFSAR	Trimmed internal reference to SAR	–1	–	1	%	Percentage of V _{bg} (1.024 V)

Note

10. A maximum of eight single-ended ADC Channels can be accomplished only if the AMUX Buses are not being used for other functionality (such as CapSense). If the AMUX Buses are being used for other functionality, then the maximum number of single-ended ADC channels is six. Similarly, if the AMUX Buses are being used for other functionality, then the maximum number of differential ADC channels is three.

Table 26. SAR ADC AC Specifications

Parameter	Description	Min	Typ	Max	Units	Details/Conditions
A_PSRR	Power-supply rejection ratio	70	–	–	dB	Measured at 1-V reference
A_CMRR	Common-mode rejection ratio	66	–	–	dB	
A_SAMP	Sample rate	–	–	1	Msp/s	
Fsarintref	SAR operating speed without external ref. bypass	–	–	100	ksps	12-bit resolution
A_SNR	Signal-to-noise ratio (SNR)	65	–	–	dB	F _{IN} = 10 kHz
A_BW	Input bandwidth without aliasing	–	–	A_SAMP/2	kHz	
A_INL	Integral nonlinearity. V _{DD} = 2.0 V to 3.6 V, 1 Msps	–1.7	–	2	LSB	V _{REF} = 1 V to V _{DD}
A_INL	Integral nonlinearity. V _{DD} = 2.0 V to 3.6 V, 1 Msps	–1.5	–	1.7	LSB	V _{REF} = 1.71 V to V _{DD}
A_INL	Integral nonlinearity. V _{DD} = 2.0 V to 3.6 V, 500 ksps	–1.5	–	1.7	LSB	V _{REF} = 1 V to V _{DD}
A_dnl	Differential nonlinearity. V _{DD} = 2.0 V to 3.6 V, 1 Msps	–1	–	2.2	LSB	V _{REF} = 1 V to V _{DD}
A_DNL	Differential nonlinearity. V _{DD} = 2.0 V to 3.6 V, 1 Msps	–1	–	2	LSB	V _{REF} = 1.71 V to V _{DD}
A_DNL	Differential nonlinearity. V _{DD} = 2.0 V to 3.6 V, 500 ksps	–1	–	2.2	LSB	V _{REF} = 1 V to V _{DD}
A_THD	Total harmonic distortion	–	–	–65	dB	F _{IN} = 10 kHz

CSD
CSD Block Specifications

Parameter	Description	Min	Typ	Max	Units	Details/Conditions
V _{CSD}	Voltage range of operation	2.0	–	3.6	V	
IDAC1	DNL for 8-bit resolution	–1	–	1	LSB	
IDAC1	INL for 8-bit resolution	–3	–	3	LSB	
IDAC2	DNL for 7-bit resolution	–1	–	1	LSB	
IDAC2	INL for 7-bit resolution	–3	–	3	LSB	
SNR	Ratio of counts of finger to noise	5	–	–	Ratio	Capacitance range of 9 pF to 35 pF, 0.1-pF sensitivity. Ratio is not operating during the scan
I _{DAC1_CRT1}	Output current of IDAC1 (8 bits) in High range	–	612	–	μA	
I _{DAC1_CRT2}	Output current of IDAC1 (8 bits) in Low range	–	306	–	μA	
I _{DAC2_CRT1}	Output current of IDAC2 (7 bits) in High range	–	305	–	μA	
I _{DAC2_CRT2}	Output current of IDAC2 (7 bits) in Low range	–	153	–	μA	

Digital Peripherals
Timer
Table 27. Timer DC Specifications

Parameter	Description	Min	Typ	Max	Units	Details/Conditions
I_{TIM1}	Block current consumption at 3 MHz	–	–	46	μA	16-bit timer, 105 °C
I_{TIM2}	Block current consumption at 12 MHz	–	–	137	μA	16-bit timer, 105 °C
I_{TIM3}	Block current consumption at 48 MHz	–	–	560	μA	16-bit timer, 105 °C

Table 28. Timer AC Specifications

Parameter	Description	Min	Typ	Max	Units	Details/Conditions
$T_{TIMFREQ}$	Operating frequency	F_{CLK}	–	48	MHz	
$T_{CAPWINT}$	Capture pulse width (internal)	$2 \times T_{CLK}$	–	–	ns	
$T_{CAPWEXT}$	Capture pulse width (external)	$2 \times T_{CLK}$	–	–	ns	
T_{TIMRES}	Timer resolution	T_{CLK}	–	–	ns	
$T_{TENWIDINT}$	Enable pulse width (internal)	$2 \times T_{CLK}$	–	–	ns	
$T_{TENWIDEXT}$	Enable pulse width (external)	$2 \times T_{CLK}$	–	–	ns	
$T_{TIMRESWINT}$	Reset pulse width (internal)	$2 \times T_{CLK}$	–	–	ns	
$T_{TIMRESEXT}$	Reset pulse width (external)	$2 \times T_{CLK}$	–	–	ns	

Counter
Table 29. Counter DC Specifications

Parameter	Description	Min	Typ	Max	Units	Details/Conditions
I_{CTR1}	Block current consumption at 3 MHz	–	–	42	μA	16-bit counter
I_{CTR2}	Block current consumption at 12 MHz	–	–	130	μA	16-bit counter
I_{CTR3}	Block current consumption at 48 MHz	–	–	535	μA	16-bit counter

Table 30. Counter AC Specifications

Parameter	Description	Min	Typ	Max	Units	Details/Conditions
$T_{CTRFREQ}$	Operating frequency	F_{CLK}	–	48	MHz	
$T_{CTRPWINT}$	Capture pulse width (internal)	$2 \times T_{CLK}$	–	–	ns	
$T_{CTRPWEXT}$	Capture pulse width (external)	$2 \times T_{CLK}$	–	–	ns	
T_{CTRES}	Counter Resolution	T_{CLK}	–	–	ns	
$T_{CENWIDINT}$	Enable pulse width (internal)	$2 \times T_{CLK}$	–	–	ns	
$T_{CENWIDEXT}$	Enable pulse width (external)	$2 \times T_{CLK}$	–	–	ns	
$T_{CTRRESWINT}$	Reset pulse width (internal)	$2 \times T_{CLK}$	–	–	ns	
$T_{CTRRESWEXT}$	Reset pulse width (external)	$2 \times T_{CLK}$	–	–	ns	

Pulse Width Modulation (PWM)
Table 31. PWM DC Specifications

Parameter	Description	Min	Typ	Max	Units	Details/Conditions
I_{PWM1}	Block current consumption at 3 MHz	–	–	42	μA	16-bit PWM
I_{PWM2}	Block current consumption at 12 MHz	–	–	130	μA	16-bit PWM
I_{PWM3}	Block current consumption at 48 MHz	–	–	535	μA	16-bit PWM

Table 32. PWM AC Specifications

Parameter	Description	Min	Typ	Max	Units	Details/Conditions
$T_{PWMFREQ}$	Operating frequency	F_{CLK}	–	48	MHz	
$T_{PWM PWINT}$	Pulse width (internal)	$2 \times T_{CLK}$	–	–	ns	
$T_{PWM EXT}$	Pulse width (external)	$2 \times T_{CLK}$	–	–	ns	
$T_{PWM KILLINT}$	Kill pulse width (internal)	$2 \times T_{CLK}$	–	–	ns	
$T_{PWM KILLEXT}$	Kill pulse width (external)	$2 \times T_{CLK}$	–	–	ns	
$T_{PWM EINT}$	Enable pulse width (internal)	$2 \times T_{CLK}$	–	–	ns	
$T_{PWM ENEXT}$	Enable pulse width (external)	$2 \times T_{CLK}$	–	–	ns	
$T_{PWM RESWINT}$	Reset pulse width (internal)	$2 \times T_{CLK}$	–	–	ns	
$T_{PWM RESWEXT}$	Reset pulse width (external)	$2 \times T_{CLK}$	–	–	ns	

LCD Direct Drive
Table 33. LCD Direct Drive DC Specifications

Parameter	Description	Min	Typ	Max	Units	Details/Conditions
I_{LCDLOW}	Operating current in low-power mode	–	17.5	–	μA	16 × 4 small segment display at 50 Hz
C_{LDCAP}	LCD capacitance per segment/common driver	–	500	5000	pF	
LCD_{OFFSET}	Long-term segment offset	–	20	–	mV	
I_{LCDOP1}	LCD system operating current $V_{BIAS} = 3.3\text{ V}$	–	2	–	mA	32 × 4 segments 50 Hz at 25 °C

Table 34. LCD Direct Drive AC Specifications

Parameter	Description	Min	Typ	Max	Units	Details/Conditions
F_{LCD}	LCD frame rate	10	50	150	Hz	

Serial Communication
Table 35. Fixed I²C DC Specifications

Parameter	Description	Min	Typ	Max	Units	Details/Conditions
I _{I2C1}	Block current consumption at 100 kHz	–	–	50	μA	–
I _{I2C2}	Block current consumption at 400 kHz	–	–	155	μA	–
I _{I2C3}	Block current consumption at 1 Mbps	–	–	390	μA	–
I _{I2C4}	I ² C enabled in Deep-Sleep mode	–	–	1.4	μA	–

Table 36. Fixed I²C AC Specifications

Parameter	Description	Min	Typ	Max	Units	Details/Conditions
F _{I2C1}	Bit rate	–	–	400	kHz	–

Table 37. Fixed UART DC Specifications

Parameter	Description	Min	Typ	Max	Units	Details/Conditions
I _{UART1}	Block current consumption at 100 kbps	–	–	55	μA	–
I _{UART2}	Block current consumption at 1000 kbps	–	–	312	μA	–

Table 38. Fixed UART AC Specifications

Parameter	Description	Min	Typ	Max	Units	Details/Conditions
F _{UART}	Bit rate	–	–	1	Mbps	–

Table 39. Fixed SPI DC Specifications

Parameter	Description	Min	Typ	Max	Units	Details/Conditions
I _{SPI1}	Block current consumption at 1 Mbps	–	–	360	μA	–
I _{SPI2}	Block current consumption at 4 Mbps	–	–	560	μA	–
I _{SPI3}	Block current consumption at 8 Mbps	–	–	600	μA	–

Table 40. Fixed SPI AC Specifications

Parameter	Description	Min	Typ	Max	Units	Details/Conditions
F _{SPI}	SPI operating frequency (master; 6x over sampling)	–	–	8	MHz	–

Table 41. Fixed SPI Master Mode AC Specifications

Parameter	Description	Min	Typ	Max	Units	Details/Conditions
T _{DMO}	MOSI valid after SCLK driving edge	–	–	18	ns	–
T _{DSI}	MISO valid before SCLK capturing edge Full clock, late MISO sampling used	20	–	–	ns	Full clock, late MISO sampling
T _{HMO}	Previous MOSI data hold time	0	–	–	ns	Referred to Slave capturing edge

Table 42. Fixed SPI Slave Mode AC Specifications

Parameter	Description	Min	Typ	Max	Units	Details/Conditions
T _{DMI}	MOSI valid before SCLK capturing edge	40	–	–	ns	–
T _{DSDO}	MISO valid after SCLK driving edge	–	–	42 + 3 × T _{SCB}	ns	–
T _{DSDO_ext}	MISO Valid after SCLK driving edge in external clock mode. V _{DD} < 3.0 V	–	–	50	ns	–
T _{HSDO}	Previous MISO data hold time	0	–	–	ns	–
T _{SSELSCK}	SSEL valid to first SCK valid edge	100	–	–	ns	–

Memory
Table 43. Flash DC Specifications

Parameter	Description	Min	Typ	Max	Units	Details/Conditions
V _{PE}	Erase and program voltage	1.71	–	5.5	V	–
T _{WS48}	Number of Wait states at 32–48 MHz	2	–	–		CPU execution from flash
T _{WS32}	Number of Wait states at 16–32 MHz	1	–	–		CPU execution from flash
T _{WS16}	Number of Wait states for 0–16 MHz	0	–	–		CPU execution from flash

Table 44. Flash AC Specifications

Parameter	Description	Min	Typ	Max	Units	Details/Conditions
T _{ROWWRITE} ^[11]	Row (block) write time (erase and program)	–	–	20	ms	Row (block) = 256 bytes
T _{ROWERASE} ^[11]	Row erase time	–	–	13	ms	–
T _{ROWPROGRAM} ^[11]	Row program time after erase	–	–	7	ms	–
T _{BULKERASE} ^[11]	Bulk erase time (256 KB)	–	–	35	ms	–
T _{DEVPROG} ^[11]	Total device program time	–	–	25	seconds	–
F _{END}	Flash endurance	100 K	–	–	cycles	–
F _{RET}	Flash retention. T _A ≤ 55 °C, 100 K P/E cycles	20	–	–	years	–
F _{RET2}	Flash retention. T _A ≤ 85 °C, 10 K P/E cycles	10	–	–	years	For 55 °C ≤ T _A ≤ 85 °C
F _{RET3}	Flash retention. T _A ≤ 105 °C, 10 K P/E cycles	3	–	–	years	For T _A ≥ 85 °C

System Resources
Power-on-Reset (POR)
Table 45. POR DC Specifications

Parameter	Description	Min	Typ	Max	Units	Details/Conditions
V _{RISEIPOR}	Rising trip voltage	0.80	–	1.45	V	–
V _{FALLIPOR}	Falling trip voltage	0.75	–	1.40	V	–
V _{IPORHYST}	Hysteresis	15	–	200	mV	–

Table 46. POR AC Specifications

Parameter	Description	Min	Typ	Max	Units	Details/Conditions
T _{PPOR_TR}	Precision power-on reset (PPOR) response time in Active and Sleep modes	–	–	1	µs	–

Table 47. Brown-Out Detect

Parameter	Description	Min	Typ	Max	Units	Details/Conditions
V _{FALLPPOR}	BOD trip voltage in Active and Sleep modes	1.64	–	–	V	–
V _{FALLDPSLP}	BOD trip voltage in Deep Sleep	1.4	–	–	V	–

Table 48. Hibernate Reset

Parameter	Description	Min	Typ	Max	Units	Details/Conditions
V _{HBRTRIP}	BOD trip voltage in Hibernate	1.1	–	–	V	–

Note

11. It can take as much as 20 ms to write to flash. During this time, the device should not be reset, or flash operations will be interrupted and cannot be relied on to have completed. Reset sources include the XRES pin, software resets, CPU lockup states and privilege violations, improper power supply levels, and watchdogs. Make certain that these are not inadvertently activated.

Voltage Monitors (LVD)
Table 49. Voltage Monitor DC Specifications

Parameter	Description	Min	Typ	Max	Units	Details/Conditions
V _{LVI1}	LVI_A/D_SEL[3:0] = 0000b	1.71	1.75	1.79	V	–
V _{LVI2}	LVI_A/D_SEL[3:0] = 0001b	1.76	1.80	1.85	V	–
V _{LVI3}	LVI_A/D_SEL[3:0] = 0010b	1.85	1.90	1.95	V	–
V _{LVI4}	LVI_A/D_SEL[3:0] = 0011b	1.95	2.00	2.05	V	–
V _{LVI5}	LVI_A/D_SEL[3:0] = 0100b	2.05	2.10	2.15	V	–
V _{LVI6}	LVI_A/D_SEL[3:0] = 0101b	2.15	2.20	2.26	V	–
V _{LVI7}	LVI_A/D_SEL[3:0] = 0110b	2.24	2.30	2.36	V	–
V _{LVI8}	LVI_A/D_SEL[3:0] = 0111b	2.34	2.40	2.46	V	–
V _{LVI9}	LVI_A/D_SEL[3:0] = 1000b	2.44	2.50	2.56	V	–
V _{LVI10}	LVI_A/D_SEL[3:0] = 1001b	2.54	2.60	2.67	V	–
V _{LVI11}	LVI_A/D_SEL[3:0] = 1010b	2.63	2.70	2.77	V	–
V _{LVI12}	LVI_A/D_SEL[3:0] = 1011b	2.73	2.80	2.87	V	–
V _{LVI13}	LVI_A/D_SEL[3:0] = 1100b	2.83	2.90	2.97	V	–
V _{LVI14}	LVI_A/D_SEL[3:0] = 1101b	2.93	3.00	3.08	V	–
V _{LVI15}	LVI_A/D_SEL[3:0] = 1110b	3.12	3.20	3.28	V	–
V _{LVI16}	LVI_A/D_SEL[3:0] = 1111b	4.39	4.50	4.61	V	–
LVI_IDD	Block current	–	–	100	μA	–

Table 50. Voltage Monitor AC Specifications

Parameter	Description	Min	Typ	Max	Units	Details/Conditions
T _{MONTRIP}	Voltage monitor trip time	–	–	1	μs	–

SWD Interface
Table 51. SWD Interface Specifications

Parameter	Description	Min	Typ	Max	Units	Details/Conditions
F _{SWDCLK1}	$3.3\text{ V} \leq V_{DD} \leq 3.6\text{ V}$	–	–	14	MHz	SWDCLK ≤ 1/3 CPU clock frequency
F _{SWDCLK2}	$2.0\text{ V} \leq V_{DD} \leq 3.3\text{ V}$	–	–	7	MHz	SWDCLK ≤ 1/3 CPU clock frequency
T _{SWDI_SETUP}	T = 1/f SWDCLK	0.25 × T	–	–	ns	–
T _{SWDI_HOLD}	T = 1/f SWDCLK	0.25 × T	–	–	ns	–
T _{SWDO_VALID}	T = 1/f SWDCLK	–	–	0.5 × T	ns	–
T _{SWDO_HOLD}	T = 1/f SWDCLK	1	–	–	ns	–

Internal Main Oscillator
Table 52. IMO DC Specifications

Parameter	Description	Min	Typ	Max	Units	Details/Conditions
I _{IMO1}	IMO operating current at 48 MHz	–	–	1000	μA	–
I _{IMO2}	IMO operating current at 24 MHz	–	–	325	μA	–
I _{IMO3}	IMO operating current at 12 MHz	–	–	225	μA	–
I _{IMO4}	IMO operating current at 6 MHz	–	–	180	μA	–
I _{IMO5}	IMO operating current at 3 MHz	–	–	150	μA	–

Table 53. IMO AC Specifications

Parameter	Description	Min	Typ	Max	Units	Details/Conditions
F _{IMOTOL3}	Frequency variation from 3 to 48 MHz	–	–	±2	%	With API-called calibration
F _{IMOTOL3}	IMO startup time	–	–	12	μs	–

Internal Low-Speed Oscillator
Table 54. ILO DC Specifications

Parameter	Description	Min	Typ	Max	Units	Details/Conditions
I _{ILO2}	ILO operating current at 32 kHz	–	0.3	1.05	μA	–

Table 55. ILO AC Specifications

Parameter	Description	Min	Typ	Max	Units	Details/Conditions
T _{STARTILO1}	ILO startup time	–	–	2	ms	–
F _{ILOTRIM1}	32-kHz trimmed frequency	15	32	50	kHz	–

Table 56. Recommended ECO Trim Value

Parameter	Description	Value	Details/Conditions
ECO _{TRIM}	24-MHz trim value (firmware configuration)	0X00005555	Recommended trim value that needs to be loaded to register CY_SYS_XTAL_BLERD_BB_XO_CAPTRIM_REG

Table 57. UDB AC Specifications

Parameter	Description	Min	Typ	Max	Units	Details/Conditions
Data Path performance						
F _{MAX-TIMER}	Max frequency of 16-bit timer in a UDB pair	–	–	48	MHz	
F _{MAX-ADDER}	Max frequency of 16-bit adder in a UDB pair	–	–	48	MHz	
F _{MAX_CRC}	Max frequency of 16-bit CRC/PRS in a UDB pair	–	–	48	MHz	
PLD Performance in UDB						
F _{MAX_PLD}	Max frequency of 2-pass PLD function in a UDB pair	–	–	48	MHz	
Clock to Output Performance						
T _{CLK_OUT_UBD1}	Prop. delay for clock in to data out at 25 °C, Typical	–	15	–	ns	
T _{CLK_OUT_UBD2}	Prop. delay for clock in to data out, Worst case	–	25	–	ns	

Table 58. Bluetooth LE Subsystem

Parameter	Description	Min	Typ	Max	Units	Details/ Conditions
RF Receiver Specification						
RXS, DIRTY	RX sensitivity with dirty transmitter	–	–95	–	dBm	With LNA active
RXS, LOWGAIN	RX sensitivity in low-gain mode with idle transmitter	–	–87	–	dBm	LNA in bypass mode
RXS, HIGHGAIN	RX sensitivity in high-gain mode with idle transmitter	–	–95	–	dBm	With LNA active
PRXMAX	Maximum input power	–10	–1	–	dBm	RF-PHY Specification (RCV-LE/CA/06/C)
CI1	Cochannel interference, Wanted signal at –67 dBm and Interferer at FRX	–	9	21	dB	RF-PHY Specification (RCV-LE/CA/03/C)
CI2	Adjacent channel interference Wanted signal at –67 dBm and Interferer at FRX ±1 MHz	–	4	–	dB	RF-PHY Specification (RCV-LE/CA/03/C)
CI3	Adjacent channel interference Wanted signal at –67 dBm and Interferer at FRX ±2 MHz	–	–23	–	dB	RF-PHY Specification (RCV-LE/CA/03/C)
CI4	Adjacent channel interference Wanted signal at –67 dBm and Interferer at ≥FRX ±3 MHz	–	–34	–	dB	RF-PHY Specification (RCV-LE/CA/03/C)
CI5	Adjacent channel interference Wanted Signal at –67 dBm and Interferer at Image frequency (F _{IMAGE})	–	–22	–	dB	RF-PHY Specification (RCV-LE/CA/03/C)
CI6	Adjacent channel interference Wanted signal at –67 dBm and Interferer at Image frequency (F _{IMAGE} ± 1 MHz)	–	–13	–	dB	RF-PHY Specification (RCV-LE/CA/03/C)
OBB1	Out-of-band blocking, Wanted signal at –67 dBm and Interferer at F = 30–2000 MHz	–	–16	–	dBm	RF-PHY Specification (RCV-LE/CA/04/C)
OBB2	Out-of-band blocking, Wanted signal at –67 dBm and Interferer at F = 2003–2399 MHz	–	–16	–	dBm	RF-PHY Specification (RCV-LE/CA/04/C)
OBB3	Out-of-band blocking, Wanted signal at –67 dBm and Interferer at F = 2484–2997 MHz	–	–16	–	dBm	RF-PHY Specification (RCV-LE/CA/04/C)
OBB4	Out-of-band blocking, Wanted signal a –67 dBm and Interferer at F = 3000–12750 MHz	–	–16	–	dBm	RF-PHY Specification (RCV-LE/CA/04/C)
IMD	Intermodulation performance Wanted signal at –64 dBm and 1-Mbps Bluetooth LE, third, fourth, and fifth offset channel	–	–26	–	dBm	RF-PHY Specification (RCV-LE/CA/05/C)
RXSE1	Receiver spurious emission 30 MHz to 1.0 GHz	–	–	–57	dBm	100-kHz measurement bandwidth ETSI EN300 328 V2.1.1

Table 58. Bluetooth LE Subsystem (continued)

Parameter	Description	Min	Typ	Max	Units	Details/ Conditions
RXSE2	Receiver spurious emission 1.0 GHz to 12.75 GHz	–	–	–47	dBm	1-MHz measurement bandwidth ETSI EN300 328 V2.1.1
RF Transmitter Specifications						
TXP, ACC	RF power accuracy	–	±4	–	dB	
TXP, RANGE	RF power control range	–	27	–	dB	
TXP, 0dBm	Output power, 0-dB Gain setting (PA7)	–	0	–	dBm	PA in All Off mode
TXP, MAX	Output power, maximum power setting	–	9.5	–	dBm	PSoC 4 Bluetooth LE silicon PA setting of –6 dBm PA/LNA in High Gain/High Sensitivity mode
TXP, MIN	Output power, minimum power setting (PA1)	–	–18	–	dBm	PA/LNA in All Off mode
F2AVG	Average frequency deviation for 10101010 pattern	185	–	–	kHz	RF-PHY Specification (TRM-LE/CA/05/C)
F1AVG	Average frequency deviation for 11110000 pattern	225	250	275	kHz	RF-PHY Specification (TRM-LE/CA/05/C)
EO	Eye opening = $\Delta F2AVG/\Delta F1AVG$	0.8	–	–		RF-PHY Specification (TRM-LE/CA/05/C)
FTX, ACC	Frequency accuracy	–150	–	150	kHz	RF-PHY Specification (TRM-LE/CA/06/C)
FTX, MAXDR	Maximum frequency drift	–50	–	50	kHz	RF-PHY Specification (TRM-LE/CA/06/C)
FTX, INITDR	Initial frequency drift	–20	–	20	kHz	RF-PHY Specification (TRM-LE/CA/06/C)
FTX, DR	Maximum drift rate	–20	–	20	kHz/ 50 μ s	RF-PHY Specification (TRM-LE/CA/06/C)
IBSE1	In-band spurious emission at 2-MHz offset	–	–	–20	dBm	RF-PHY Specification (TRM-LE/CA/03/C)
IBSE2	In-band spurious emission at ≥ 3 -MHz offset	–	–	–30	dBm	RF-PHY Specification (TRM-LE/CA/03/C)
TXSE1	Transmitter spurious emissions (average), <1.0 GHz	–	–	–55.5	dBm	FCC-15.247
TXSE2	Transmitter spurious emissions (average), >1.0 GHz	–	–	–41.5	dBm	FCC-15.247
RF Current Specifications						
IRX	Receive current in normal mode	–	18.7	–	mA	Silicon Radio only, PA/LNA disabled
IRX_RF	Radio receive current in normal mode	–	16.4	–	mA	Silicon Radio only, PA/LNA disabled
IRX, HIGHGAIN	Receive current in high-gain mode	–	21.5	–	mA	Silicon Radio only, PA/LNA disabled
ITX, 3dBm	TX current at 3-dBm setting (PA10)	–	20	–	mA	Silicon Radio only, PA/LNA disabled
ITX, 0dBm	TX current at 0-dBm setting (PA7)	–	16.5	–	mA	Silicon Radio only, PA/LNA disabled

Table 58. Bluetooth LE Subsystem (continued)

Parameter	Description	Min	Typ	Max	Units	Details/ Conditions
ITX_RF, 0dBm	Radio TX current at 0 dBm setting (PA7)	–	15.6	–	mA	Silicon Radio only, PA/LNA disabled
ITX_RF, 0dBm	Radio TX current at 0 dBm excluding Balun loss	–	14.2	–	mA	Guaranteed by design simulation
ITX,-3dBm	TX current at –3-dBm setting (PA4)	–	15.5	–	mA	Silicon Radio only, PA/LNA disabled
ITX,-6dBm	TX current at –6-dBm setting (PA3)	–	14.5	–	mA	Silicon Radio only, PA/LNA disabled
ITX,-12dBm	TX current at –12-dBm setting (PA2)	–	13.2	–	mA	Silicon Radio only, PA/LNA disabled
ITX,-18dBm	TX current at –18-dBm setting (PA1)	–	12.5	–	mA	Silicon Radio only, PA/LNA disabled
lavg_1sec, +9.5dBm	Average current at 1-second Bluetooth LE connection interval	–	26.3	–	μA	TXP: +9.5 dBm; ±20-ppm master and slave clock accuracy. For empty PDU exchange PA/LNA active
lavg_4sec, +9.5dBm	Average current at 4-second Bluetooth LE connection interval	–	14.3	–	μA	TXP: +9.5 dBm; ±20-ppm master and slave clock accuracy. For empty PDU exchange PA/LNA active
General RF Specifications						
FREQ	RF operating frequency	2400	–	2482	MHz	
CHBW	Channel spacing	–	2	–	MHz	
DR	On-air data rate	–	1000	–	kbps	
IDLE2TX	Bluetooth LE.IDLE to Bluetooth LE. TX transition time	–	120	140	μs	
IDLE2RX	Bluetooth LE.IDLE to Bluetooth LE. RX transition time	–	75	120	μs	
RSSI Specifications						
RSSI, ACC	RSSI accuracy	–	±5	–	dB	
RSSI, RES	RSSI resolution	–	1	–	dB	
RSSI, PER	RSSI sample period	–	6	–	μs	

Environmental Specifications

Environmental Compliance

This Cypress Bluetooth LE module is built in compliance with the Restriction of Hazardous Substances (RoHS) and Halogen Free (HF) directives. The Cypress module and components used to produce this module are RoHS and HF compliant.

RF Certification

The CYBLE-224116-01 module is certified under the following RF certification standards:

- FCC ID: WAP4110
- CE
- IC: 7922A-4110
- MIC: 203-JN0568
- KC: MSIP-CRM-Cyp-4110

Safety Certification

The CYBLE-224116-01 module complies with the following safety regulations:

- Underwriters Laboratories, Inc. (UL): Filing E331901
- CSA
- TUV

Environmental Conditions

Table 59 describes the operating and storage conditions for the Cypress Bluetooth LE module.

Table 59. Environmental Conditions for CYBLE-224116-01

Description	Minimum Specification	Maximum Specification
Operating temperature	-40 °C	105 °C
Operating humidity (relative, non-condensation)	5%	85%
Thermal ramp rate	–	3 °C/minute
Storage temperature	-40 °C	110 °C
Storage temperature and humidity	–	110 °C at 85%
ESD: Module integrated into system Components ^[12]	–	15 kV Air 2.2 kV Contact

ESD and EMI Protection

Exposed components require special attention to ESD and electromagnetic interference (EMI).

A grounded conductive layer inside the device enclosure is suggested for EMI and ESD performance. Any openings in the enclosure near the module should be surrounded by a grounded conductive layer to provide ESD protection and a low-impedance path to ground.

Device Handling: Proper ESD protocol must be followed in manufacturing to ensure component reliability.

Note

12. This does not apply to the RF pins (ANT, XTALI, and XTALO). RF pins (ANT, XTALI, and XTALO) are tested for 500-V HBM.

Regulatory Information

FCC

FCC NOTICE:

The device CYBLE-224116-01 complies with Part 15 of the FCC Rules. The device meets the requirements for modular transmitter approval as detailed in FCC public Notice DA00-1407. Transmitter Operation is subject to the following two conditions: (1) This device may not cause harmful interference, and (2) This device must accept any interference received, including interference that may cause undesired operation.

CAUTION:

The FCC requires the user to be notified that any changes or modifications made to this device that are not expressly approved by Cypress Semiconductor may void the user's authority to operate the equipment.

This equipment has been tested and found to comply with the limits for a Class B digital device, pursuant to Part 15 of the FCC Rules. These limits are designed to provide reasonable protection against harmful interference in a residential installation. This equipment generates and can radiate radio frequency energy and, if not installed and used in accordance with the instructions, may cause harmful interference to radio communications. However, there is no guarantee that interference will not occur in a particular installation. If this equipment does cause harmful interference to radio or television reception, which can be determined by turning the equipment off and on, the user is encouraged to try to correct the interference by one or more of the following measures:

- Reorient or relocate the receiving antenna.
- Increase the separation between the equipment and receiver.
- Connect the equipment into an outlet on a circuit different from that to which the receiver is connected.
- Consult the dealer or an experienced radio/TV technician for help

LABELING REQUIREMENTS:

The Original Equipment Manufacturer (OEM) must ensure that FCC labelling requirements are met. This includes a clearly visible label on the outside of the OEM enclosure specifying the appropriate Cypress Semiconductor FCC identifier for this product as well as the FCC Notice above. The FCC identifier is FCC ID: WAP4110.

In any case the end product must be labeled exterior with "Contains FCC ID: WAP4110"

ANTENNA WARNING:

This device is tested with a standard SMA connector and with the antenna listed in [Table 7](#) on page 15. When integrated in the OEMs product, these fixed antennas require installation preventing end-users from replacing them with non-approved antennas. Any antenna not in the following table must be tested to comply with FCC Section 15.203 for unique antenna connectors and Section 15.247 for emissions.

RF EXPOSURE:

To comply with FCC RF Exposure requirements, the Original Equipment Manufacturer (OEM) must ensure to install the approved antenna in the previous.

The preceding statement must be included as a CAUTION statement in manuals, for products operating with the approved antenna in [Table 7](#) on page 15, to alert users on FCC RF Exposure compliance. Any notification to the end user of installation or removal instructions about the integrated radio module is not allowed.

The radiated output power of CYBLE-224116-01 is far below the FCC radio frequency exposure limits. Nevertheless, use CYBLE-224116-01 in such a manner that minimizes the potential for human contact during normal operation.

End users may not be provided with the module installation instructions. OEM integrators and end users must be provided with transmitter operating conditions for satisfying RF exposure compliance.

ISED

Innovation, Science and Economic Development (ISED) Canada Certification

CYBLE-224116-01 is licensed to meet the regulatory requirements of Innovation, Science and Economic Development (ISED) Canada.

License: IC: 7922A-4110

Manufacturers of mobile, fixed, or portable devices incorporating this module are advised to clarify any regulatory questions and ensure compliance for SAR and/or RF exposure limits. Users can obtain Canadian information on RF exposure and compliance from www.ic.gc.ca.

This device has been designed to operate with the antennas listed in [Table 7](#) on page 15, having a maximum gain of 0.5 dBi. Antennas not included in this list or having a gain greater than 0.5 dBi are strictly prohibited for use with this device. The required antenna impedance is 50 ohms. The antenna used for this transmitter must not be co-located or operating in conjunction with any other antenna or transmitter.

ISED NOTICE:

The device CYBLE-224116-01 including the built-in chip antenna complies with Canada RSS-GEN Rules. The device meets the requirements for modular transmitter approval as detailed in RSS-GEN. Operation is subject to the following two conditions: (1) This device may not cause harmful interference, and (2) This device must accept any interference received, including interference that may cause undesired operation.

L'appareil CYBLE-224116-01, y compris l'antenne intégrée, est conforme aux Règles RSS-GEN de Canada. L'appareil répond aux exigences d'approbation de l'émetteur modulaire tel que décrit dans RSS-GEN. L'opération est soumise aux deux conditions suivantes: (1) Cet appareil ne doit pas causer d'interférences nuisibles, et (2) Cet appareil doit accepter toute interférence reçue, y compris les interférences pouvant entraîner un fonctionnement indésirable.

ISED INTERFERENCE STATEMENT FOR CANADA

This device complies with Innovation, Science and Economic Development (ISED) Canada licence-exempt RSS standard(s). Operation is subject to the following two conditions: (1) this device may not cause interference, and (2) this device must accept any interference, including interference that may cause undesired operation of the device.

Cet appareil est conforme à la norme sur l'innovation, la science et le développement économique (ISED) norme RSS exempte de licence. L'exploitation est autorisée aux deux conditions suivantes : (1) l'appareil ne doit pas produire de brouillage, et (2) l'utilisateur de l'appareil doit accepter tout brouillage radioélectrique subi, même si le brouillage est susceptible d'en compromettre le fonctionnement.

ISED RADIATION EXPOSURE STATEMENT FOR CANADA

This equipment complies with ISED radiation exposure limits set forth for an uncontrolled environment.

This equipment should be installed and operated with a minimum distance of 10 mm between the radiator and your body.

Cet équipement est conforme aux limites d'exposition aux radiations ISED prévues pour un environnement incontrôlé.

Cet équipement doit être installé et utilisé avec un minimum de 10 mm de distance entre la source de rayonnement et votre corps.

LABELING REQUIREMENTS:

The Original Equipment Manufacturer (OEM) must ensure that ISED labelling requirements are met. This includes a clearly visible label on the outside of the OEM enclosure specifying the appropriate Cypress Semiconductor IC identifier for this product as well as the ISED Notice above. The IC identifier is 7922A-4110. In any case, the end product must be labeled in its exterior with "Contains IC: 7922A-4110".

European Declaration of Conformity

Hereby, Cypress Semiconductor declares that the Bluetooth module CYBLE-224116-01 complies with the essential requirements and other relevant provisions of Directive 2014. As a result of the conformity assessment procedure described in Annex III of the Directive 2014, the end-customer equipment should be labeled as follows:



All versions of the CYBLE-224116-01 in the specified reference design can be used in the following countries: Austria, Belgium, Cyprus, Czech Republic, Denmark, Estonia, Finland, France, Germany, Greece, Hungary, Ireland, Italy, Latvia, Lithuania, Luxembourg, Malta, Poland, Portugal, Slovakia, Slovenia, Spain, Sweden, The Netherlands, the United Kingdom, Switzerland, and Norway.

MIC Japan

CYBLE-224116-01 is certified as a module with type certification number 203-JN0568. End products that integrate CYBLE-224116-01 do not need additional MIC Japan certification for the end product.

End product can display the certification label of the embedded module.

Model Name: EZ-BLE PSoC XT/XR Module

Part Number: CYBLE-224116-01

Manufactured by Cypress Semiconductor.



203-JN0568

KC Korea

CYBLE-224116-01 is certified for use in Korea with certificate number MSIP-CRM-Cyp-4110.

한국 인증 세부정보:



1. 제품명(모델명): 특정소출력무선기기(무선데이터통신시스템용 무선기기), CYBLE-224116-01
2. 인증 번호: MSIP-CRM-Cyp-4110
3. 라이선스 소유자: Cypress Semiconductor Corporation
4. 제조일자: 2016.5
5. 제조업체/국가명: Cypress Semiconductor Corporation/ 중국

해당 무선설비는 전파혼신 가능성이 있으므로 인명안전과 관련된 서비스는 할 수 없습니다.

Packaging

Table 60. Solder Reflow Peak Temperature

Module Part Number	Package	Maximum Peak Temperature	Maximum Time at Peak Temperature	No. of Cycles
CYBLE-224116-01	32-pad SMT	260 °C	30 seconds	2

Table 61. Package Moisture Sensitivity Level (MSL), IPC/JEDEC J-STD-2

Module Part Number	Package	MSL
CYBLE-224116-01	32-pad SMT	MSL 3

The CYBLE-224116-01 is offered in tape and reel packaging. Figure 10 details the tape dimensions used for the CYBLE-224116-01.

Figure 10. CYBLE-224116-01 Tape Dimensions

Item	W	A ₀	B ₀	K ₀	P ₁	F	E	D ₀	D ₁	P ₀	P ₂	T
Measurement	24.0 ^{+0.30} _{-0.20}	9.8 ^{+0.10} _{-0.10}	15.7 ^{+0.10} _{-0.10}	2.00 ^{+0.10} _{-0.20}	16.0 ^{+0.10} _{-0.10}	11.5 ^{+0.10} _{-0.10}	1.75 ^{+0.10} _{-0.10}	1.50 ^{+0.10} _{-0.00}	1.50 ^{+0.10} _{-0.10}	4.00 ^{+0.10} _{-0.10}	2.00 ^{+0.20} _{-0.20}	0.30 ^{+0.00} _{-0.00}

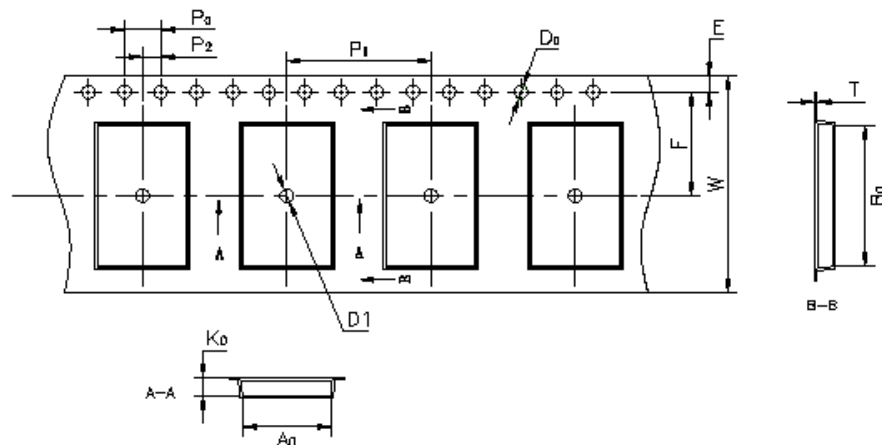

Figure 11 details the orientation of the CYBLE-224116-01 in the tape as well as the direction for unreeling.

Figure 11. Component Orientation in Tape and Unreeling Direction

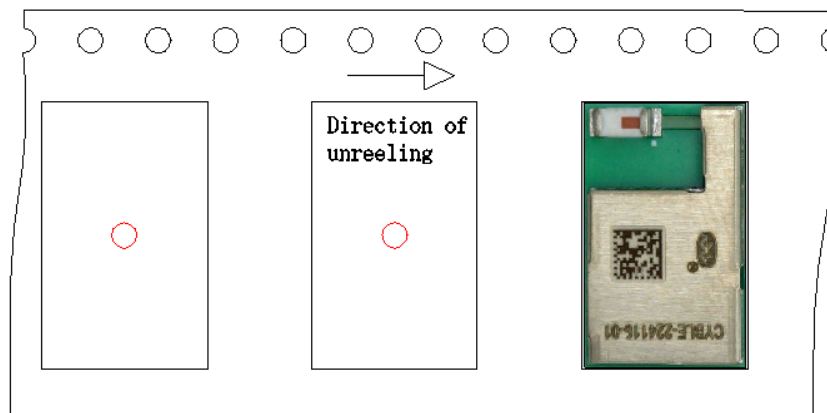
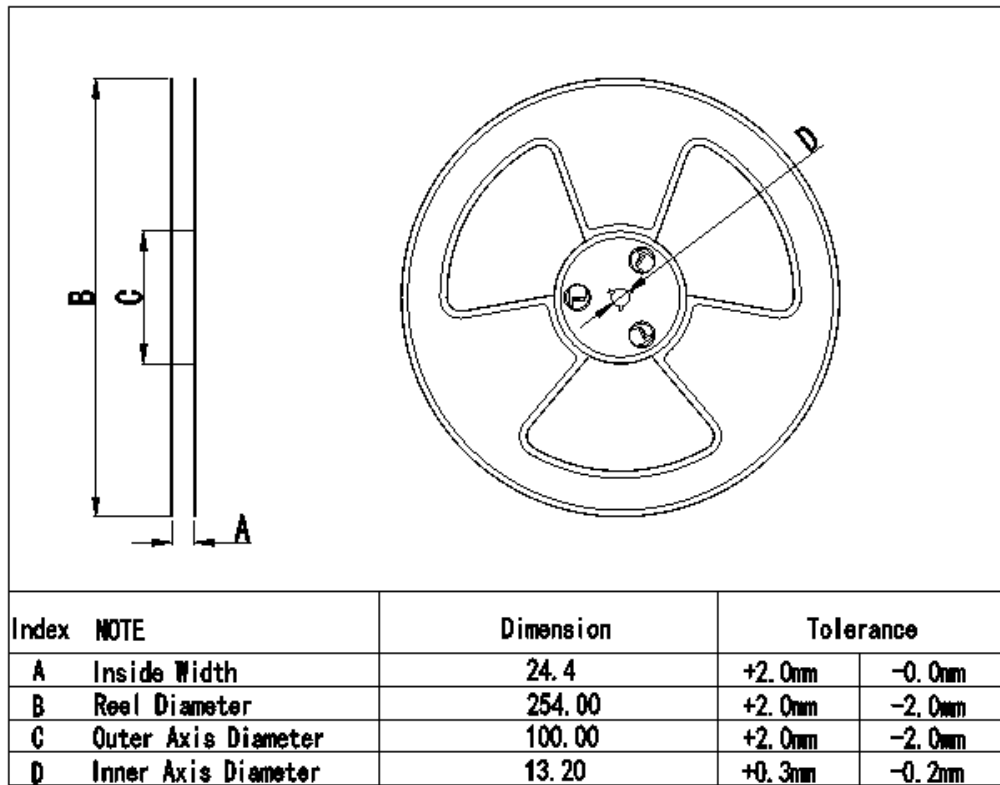

Figure 12 details reel dimensions used for the CYBLE-224116-01.

Figure 12. Reel Dimensions



The CYBLE-224116-01 is designed to be used with pick-and-place equipment in an SMT manufacturing environment. The center-of-mass for the CYBLE-224116-01 is detailed in Figure 13.

Figure 13. CYBLE-224116-01 Center of Mass (Seen from Top)

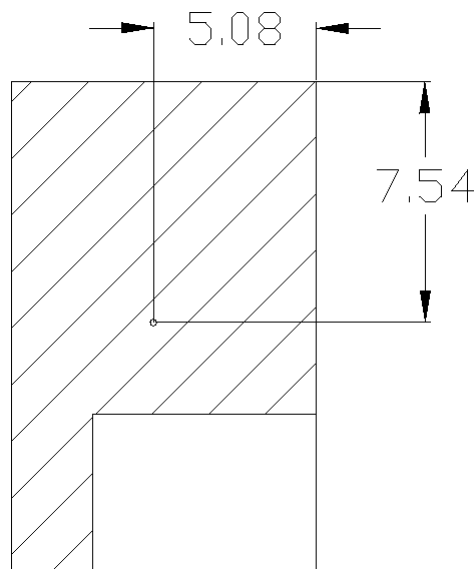

Ordering Information

Table 62 lists the CYBLE-224116-01 part number and features. Table 63 lists the reel shipment quantities for the CYBLE-224116-01.

Table 62. Ordering Information

MPN	Features															Package	
	Max CPU Speed (MHz)	Flash (KB)	SRAM (KB)	Power Amplifier (PA)	Low Noise Amplifier (LNA)	UDB	Opamp (CTBm)	CapSense	Direct LCD Drive	12-bit SAR ADC	LP Comparators	TCPWM Blocks	SCB Blocks	PWMs (using UDBs)	I2S (using UDB)		GPIO
CYBLE-224116-01	48	256	32	✓	✓	4	4	✓	✓	1 Msp/s	1	4	2	4	✓	25	32-SMT

Table 63. Tape and Reel Package Quantity and Minimum Order Amount

Description	Minimum Reel Quantity	Maximum Reel Quantity	Comments
Reel Quantity	500	500	Ships in 500 unit reel quantities.
Minimum Order Quantity (MOQ)	500	–	
Order Increment (OI)	500	–	

The CYBLE-224116-01 is offered in tape and reel packaging. The CYBLE-224116-01 ships with a maximum of 500 units/reel.

Part Numbering Convention

The part numbers are of the form CYBLE-FATT##-SB where the fields are defined as follows.

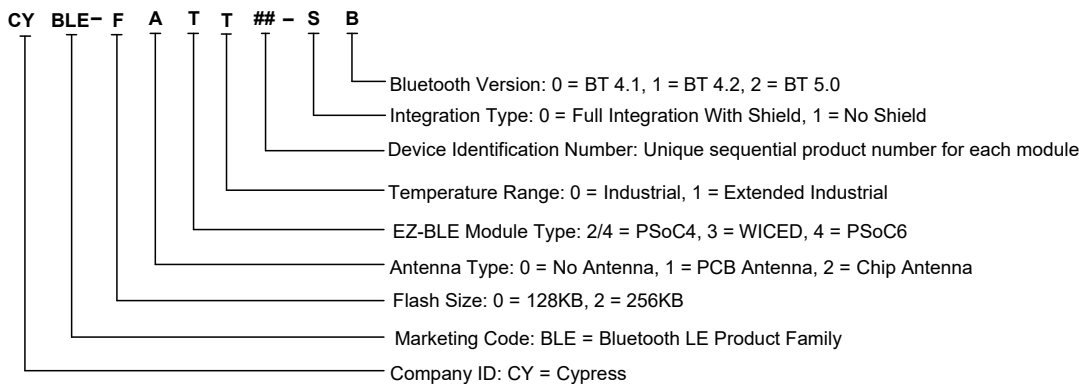

For additional information and a complete list of Cypress Semiconductor Bluetooth LE products, contact your local Cypress sales representative. To locate the nearest Cypress office, visit our website.

U.S. Cypress Headquarters Address	198 Champion Court, San Jose, CA 95134
U.S. Cypress Headquarter Contact Info	(408) 943-2600
Cypress website address	http://www.cypress.com

Acronyms

Table 64. Acronyms Used in this Document

Acronym	Description
ABUS	analog local bus
ADC	analog-to-digital converter
AG	analog global
AHB	AMBA (advanced microcontroller bus architecture) high-performance bus, an ARM data transfer bus
ALU	arithmetic logic unit
AMUXBUS	analog multiplexer bus
API	application programming interface
APSR	application program status register
ARM®	advanced RISC machine, a CPU architecture
ATM	automatic thump mode
BLE	Bluetooth Low Energy
Bluetooth SIG	Bluetooth Special Interest Group
BW	bandwidth
CAN	Controller Area Network, a communications protocol
CE	European Conformity
CSA	Canadian Standards Association
CMRR	common-mode rejection ratio
CPU	central processing unit
CRC	cyclic redundancy check, an error-checking protocol
DAC	digital-to-analog converter, see also IDAC, VDAC
DFB	digital filter block
DIO	digital input/output, GPIO with only digital capabilities, no analog. See GPIO.
DMIPS	Dhrystone million instructions per second
DMA	direct memory access, see also TD
DNL	differential nonlinearity, see also INL
DNU	do not use
DR	port write data registers
DSI	digital system interconnect
DWT	data watchpoint and trace
ECC	error correcting code
ECO	external crystal oscillator
EEPROM	electrically erasable programmable read-only memory
EMI	electromagnetic interference

Table 64. Acronyms Used in this Document (continued)

Acronym	Description
EMIF	external memory interface
EOC	end of conversion
EOF	end of frame
EPSR	execution program status register
ESD	electrostatic discharge
ETM	embedded trace macrocell
FCC	Federal Communications Commission
FET	field-effect transistor
FIR	finite impulse response, see also IIR
FPB	flash patch and breakpoint
FS	full-speed
GPIO	general-purpose input/output, applies to a PSoC pin
HCI	host controller interface
HVI	high-voltage interrupt, see also LVI, LVD
IC	integrated circuit
IDAC	current DAC, see also DAC, VDAC
IDE	integrated development environment
I ² C, or IIC	Inter-Integrated Circuit, a communications protocol
IC	Industry Canada
IIR	infinite impulse response, see also FIR
ILO	internal low-speed oscillator, see also IMO
IMO	internal main oscillator, see also ILO
INL	integral nonlinearity, see also DNL
I/O	input/output, see also GPIO, DIO, SIO, USBIO
IPOR	initial power-on reset
IPSR	interrupt program status register
IRQ	interrupt request
ITM	instrumentation trace macrocell
KC	Korea Certification
LCD	liquid crystal display
LIN	Local Interconnect Network, a communications protocol.
LNA	low noise amplifier
LR	link register
LUT	lookup table
LVD	low-voltage detect, see also LVI
LVI	low-voltage interrupt, see also HVI

Table 64. Acronyms Used in this Document (continued)

Acronym	Description
LVTTTL	low-voltage transistor-transistor logic
MAC	multiply-accumulate
MCU	microcontroller unit
MIC	Ministry of Internal Affairs and Communications (Japan)
MISO	master-in slave-out
NC	no connect
NMI	nonmaskable interrupt
NRZ	non-return-to-zero
NVIC	nested vectored interrupt controller
NVL	nonvolatile latch, see also WOL
Opamp	operational amplifier
PA	power amplifier
PAL	programmable array logic, see also PLD
PC	program counter
PCB	printed circuit board
PGA	programmable gain amplifier
PHUB	peripheral hub
PHY	physical layer
PICU	port interrupt control unit
PLA	programmable logic array
PLD	programmable logic device, see also PAL
PLL	phase-locked loop
PMDD	package material declaration data sheet
POR	power-on reset
PRES	precise power-on reset
PRS	pseudo random sequence
PS	port read data register
PSoC®	Programmable System-on-Chip™
PSRR	power supply rejection ratio
PWM	pulse-width modulator
QDID	qualification design ID
RAM	random-access memory
RISC	reduced-instruction-set computing
RMS	root-mean-square
RTC	real-time clock
RTL	register transfer language
RTR	remote transmission request
RX	receive
SAR	successive approximation register

Table 64. Acronyms Used in this Document (continued)

Acronym	Description
SC/CT	switched capacitor/continuous time
SCL	I ² C serial clock
SDA	I ² C serial data
S/H	sample and hold
SINAD	signal to noise and distortion ratio
SIO	special input/output, GPIO with advanced features. See GPIO.
SMT	surface-mount technology; a method for producing electronic circuitry in which the components are placed directly onto the surface of PCBs
SOC	start of conversion
SOF	start of frame
SPI	Serial Peripheral Interface, a communications protocol
SR	slew rate
SRAM	static random access memory
SRES	software reset
STN	super twisted nematic
SWD	serial wire debug, a test protocol
SWV	single-wire viewer
TD	transaction descriptor, see also DMA
THD	total harmonic distortion
TIA	transimpedance amplifier
TN	twisted nematic
TRM	technical reference manual
TTL	transistor-transistor logic
TUV	Germany: Technischer Überwachungs-Verein (Technical Inspection Association)
TX	transmit
UART	Universal Asynchronous Transmitter Receiver, a communications protocol
UDB	universal digital block
USB	Universal Serial Bus
USBIO	USB input/output, PSoC pins used to connect to a USB port
VDAC	voltage DAC, see also DAC, IDAC
WDT	watchdog timer
WOL	write once latch, see also NVL
WRES	watchdog timer reset
XRES	external reset I/O pin
XTAL	crystal

Document Conventions

Units of Measure

Table 65. Units of Measure

Symbol	Unit of Measure
°C	degrees Celsius
dB	decibel
dBm	decibel-milliwatts
fF	femtofarads
Hz	hertz
KB	1024 bytes
kbps	kilobits per second
Khr	kilohour
kHz	kilohertz
kΩ	kilo ohm
ksps	kilosamples per second
LSB	least significant bit
Mbps	megabits per second
MHz	megahertz
MΩ	mega-ohm
Msp	megasamples per second
μA	microampere
μF	microfarad
μH	microhenry
μs	microsecond
μV	microvolt
μW	microwatt
mA	milliampere
ms	millisecond
mV	millivolt
nA	nanoampere
ns	nanosecond
nV	nanovolt
Ω	ohm
pF	picofarad
ppm	parts per million
ps	picosecond
s	second
sps	samples per second
sqrtHz	square root of hertz
V	volt

Document History Page

Document Title: CYBLE-224116-01, EZ-BLE™ Creator XT/XR Module Document Number: 002-12524			
Revision	ECN	Submission Date	Description of Change
**	5423179	09/01/2016	Preliminary datasheet for CYBLE-224116-01 module.
*A	5536076	11/29/2016	<p>Updated More Information: Added EZ-Serial™ Bluetooth LE Firmware Platform. Updated Overview: Added Bluetooth Declaration ID and QDID under "Bluetooth 5.1 qualified single-mode module" Updated Recommended Host PCB Layout: Updated Figure 4, Figure 5, and Figure 6 captions to specify that these as "Seen on Host PCB". Updated Power Supply Connections and Recommended External Components: Updated Figure 7 and Figure 8 to specify that these are "Seen from Bottom". Updated Digital and Analog Capabilities and Connections: Updated Table 4: Updated TCPWM column to add TCPWM capability on Port 2 pins. Added Footnote 5. Completing Sunset Review.</p>
*B	5554670	12/15/2016	<p>Updated Table 5: Port 2.x OPAMP definitions changed to CTBm0 instead of CTBm1. Updated Electrical Specifications: Updated SAR ADC: Updated Table 25 to add Note 10 to specify under what conditions the maximum number of ADC channels can be achieved. Updated System Resources: Updated Table 58: Update "CI2" typical specification parameter from "TBD" to 4 dB. Update "CI3" typical specification parameter from "TBD" to -23 dB. Update "CI4" typical specification parameter from "TBD" to -34 dB. Update "CI5" typical specification parameter from "TBD" to -22 dB. Change "CI3" to "CI6" and update typical specification parameter from "TBD" to -13 dB. Update "OBB1" typical specification parameter from "TBD" to -16 dBm. Update "OBB2" typical specification parameter from "TBD" to -16 dBm. Update "OBB3" typical specification parameter from "TBD" to -16 dBm. Update "OBB4" typical specification parameter from "TBD" to -16 dBm. Update "IMD" typical specification parameter from "TBD" to -26 dBm. Update "RXSE1" maximum specification parameter from "TBD" to -57 dBm. Update "RXSE2" maximum specification parameter from "TBD" to -47 dBm. Update "TXSE1" maximum specification parameter from "TBD" to -55.5 dBm. Update "TXSE2" maximum specification parameter from "TBD" to -41.5 dBm. Update "IBSE1" maximum specification parameter from "TBD" to -20 dBm. Update "IBSE2" maximum specification parameter from "TBD" to -30 dBm. Update "EO" minimum specification parameter from "TBD" to 0.8. Completing Sunset Review.</p>

Document History Page (continued)

Document Title: CYBLE-224116-01, EZ-BLE™ Creator XT/XR Module Document Number: 002-12524			
Revision	ECN	Submission Date	Description of Change
*C	5787527	06/27/2017	<p>Changed status from Preliminary to Final.</p> <p>Updated Enabling Extended Range Feature on page 16 to state proper PA/LNA setting when not using Extended Range functionality.</p> <p>Update references using term “Trace Antenna” to “Chip Antenna”.</p> <p>Updated power supply voltage range for V_{DD} signal throughout document to 2.0 V to 3.6 V to due to CPS/CSD PA/LNA interface pins requiring input/output voltage in this range:</p> <p>Updated Power Supply Connections and Recommended External Components on page 12;</p> <p>Updated Figure 8 on page 13;</p> <p>Updated Table 4, Table 5, Table 11, Table 12, Table 13, Table 14, Table 15, Table 16, Table 18, Table 19, Table 21, Table 23, Table 26, Table 33, and Table 51.</p> <p>Updated ISED on page 37 to latest ISED documentation requirements.</p> <p>Updated European Declaration of Conformity on page 38 to latest European regulatory requirements.</p> <p>Updated to new template.</p> <p>Completing Sunset Review.</p>
*D	6006702	12/27/2017	<p>Updated Packaging:</p> <p>Updated Figure 10 (Updated reel dimensions).</p> <p>Updated Figure 12 (Updated reel dimensions).</p> <p>Updated to new template.</p> <p>Completing Sunset Review.</p>
*E	6091378	03/15/2018	<p>Updated Document Title to read as “CYBLE-224116-01, EZ-BLE™ Creator XT/XR Module”.</p> <p>Replaced “PSoC XT/XR module” with “Creator XT/XR module” in all instances across the document.</p> <p>Updated General Description:</p> <p>Updated Module Description:</p> <p>Updated hyperlinks (Updated the links of QDID and Declaration ID as “https://launchstudio.bluetooth.com/ListingDetails/2182”).</p> <p>Updated More Information:</p> <p>Updated description.</p> <p>Updated hyperlinks.</p> <p>Updated Regulatory Information:</p> <p>Updated ISED:</p> <p>Updated description (Added “This equipment should be installed and operated with a minimum distance of 10 mm between the radiator and your body” and “Cet équipement doit être installé et utilisé avec un minimum de 10 mm de distance entre la source de rayonnement et votre corps” under ISED RADIATION EXPOSURE STATEMENT FOR CANADA).</p> <p>Updated Ordering Information:</p> <p>No change in part numbers.</p> <p>Updated Part Numbering Convention.</p>
*F	6974182	09/28/2020	<p>Updated to new template.</p> <p>Completing Sunset Review.</p>
*G	7051348	12/22/2020	<p>Changed from Bluetooth Low Energy (BLE) to Bluetooth Low Energy and BLE to Bluetooth LE throughout the document.</p>
*H	7135752	05/07/2021	<p>Updated General Description:</p> <p>Updated description.</p> <p>Updated Module Description:</p> <p>Updated description.</p> <p>Updated hyperlinks.</p> <p>Updated Two Design Environments to Get You Started Quickly:</p> <p>Updated PSoC® Creator™ Integrated Design Environment (IDE):</p> <p>Updated description.</p>

Sales, Solutions, and Legal Information

Worldwide Sales and Design Support

Cypress maintains a worldwide network of offices, solution centers, manufacturer's representatives, and distributors. To find the office closest to you, visit us at [Cypress Locations](#).

Products

Arm [®] Cortex [®] Microcontrollers	cypress.com/arm
Automotive	cypress.com/automotive
Clocks & Buffers	cypress.com/clocks
Interface	cypress.com/interface
Internet of Things	cypress.com/iot
Memory	cypress.com/memory
Microcontrollers	cypress.com/mcu
PSoC	cypress.com/psoc
Power Management ICs	cypress.com/pmic
Touch Sensing	cypress.com/touch
USB Controllers	cypress.com/usb
Wireless Connectivity	cypress.com/wireless

PSoC[®] Solutions

[PSoC 1](#) | [PSoC 3](#) | [PSoC 4](#) | [PSoC 5LP](#) | [PSoC 6 MCU](#)

Cypress Developer Community

[Community](#) | [Code Examples](#) | [Projects](#) | [Video](#) | [Blogs](#) | [Training](#) | [Components](#)

Technical Support

cypress.com/support

© Cypress Semiconductor Corporation, 2016–2021. This document is the property of Cypress Semiconductor Corporation and its subsidiaries ("Cypress"). This document, including any software or firmware included or referenced in this document ("Software"), is owned by Cypress under the intellectual property laws and treaties of the United States and other countries worldwide. Cypress reserves all rights under such laws and treaties and does not, except as specifically stated in this paragraph, grant any license under its patents, copyrights, trademarks, or other intellectual property rights. If the Software is not accompanied by a license agreement and you do not otherwise have a written agreement with Cypress governing the use of the Software, then Cypress hereby grants you a personal, non-exclusive, nontransferable license (without the right to sublicense) (1) under its copyright rights in the Software (a) for Software provided in source code form, to modify and reproduce the Software solely for use with Cypress hardware products, only internally within your organization, and (b) to distribute the Software in binary code form externally to end users (either directly or indirectly through resellers and distributors), solely for use on Cypress hardware product units, and (2) under those claims of Cypress's patents that are infringed by the Software (as provided by Cypress, unmodified) to make, use, distribute, and import the Software solely for use with Cypress hardware products. Any other use, reproduction, modification, translation, or compilation of the Software is prohibited.

TO THE EXTENT PERMITTED BY APPLICABLE LAW, CYPRESS MAKES NO WARRANTY OF ANY KIND, EXPRESS OR IMPLIED, WITH REGARD TO THIS DOCUMENT OR ANY SOFTWARE OR ACCOMPANYING HARDWARE, INCLUDING, BUT NOT LIMITED TO, THE IMPLIED WARRANTIES OF MERCHANTABILITY AND FITNESS FOR A PARTICULAR PURPOSE. No computing device can be absolutely secure. Therefore, despite security measures implemented in Cypress hardware or software products, Cypress shall have no liability arising out of any security breach, such as unauthorized access to or use of a Cypress product. CYPRESS DOES NOT REPRESENT, WARRANT, OR GUARANTEE THAT CYPRESS PRODUCTS, OR SYSTEMS CREATED USING CYPRESS PRODUCTS, WILL BE FREE FROM CORRUPTION, ATTACK, VIRUSES, INTERFERENCE, HACKING, DATA LOSS OR THEFT, OR OTHER SECURITY INTRUSION (collectively, "Security Breach"). Cypress disclaims any liability relating to any Security Breach, and you shall and hereby do release Cypress from any claim, damage, or other liability arising from any Security Breach. In addition, the products described in these materials may contain design defects or errors known as errata which may cause the product to deviate from published specifications. To the extent permitted by applicable law, Cypress reserves the right to make changes to this document without further notice. Cypress does not assume any liability arising out of the application or use of any product or circuit described in this document. Any information provided in this document, including any sample design information or programming code, is provided only for reference purposes. It is the responsibility of the user of this document to properly design, program, and test the functionality and safety of any application made of this information and any resulting product. "High-Risk Device" means any device or system whose failure could cause personal injury, death, or property damage. Examples of High-Risk Devices are weapons, nuclear installations, surgical implants, and other medical devices. "Critical Component" means any component of a High-Risk Device whose failure to perform can be reasonably expected to cause, directly or indirectly, the failure of the High-Risk Device, or to affect its safety or effectiveness. Cypress is not liable, in whole or in part, and you shall and hereby do release Cypress from any claim, damage, or other liability arising from any use of a Cypress product as a Critical Component in a High-Risk Device. You shall indemnify and hold Cypress, its directors, officers, employees, agents, affiliates, distributors, and assigns harmless from and against all claims, costs, damages, and expenses, arising out of any claim, including claims for product liability, personal injury or death, or property damage arising from any use of a Cypress product as a Critical Component in a High-Risk Device. Cypress products are not intended or authorized for use as a Critical Component in any High-Risk Device except to the limited extent that (i) Cypress's published data sheet for the product explicitly states Cypress has qualified the product for use in a specific High-Risk Device, or (ii) Cypress has given you advance written authorization to use the product as a Critical Component in the specific High-Risk Device and you have signed a separate indemnification agreement.

Cypress, the Cypress logo, Spansion, the Spansion logo, and combinations thereof, WICED, PSoC, CapSense, EZ-USB, F-RAM, and Traveo are trademarks or registered trademarks of Cypress in the United States and other countries. For a more complete list of Cypress trademarks, visit cypress.com. Other names and brands may be claimed as property of their respective owners.

Looking for pricing, stock, or lifecycle information?

Click below to explore more details on WIN SOURCE:

- ⊖ [View CS5173GDR8 on WIN SOURCE](#)
- ⊖ [MICROSS/On Semiconductor Information](#)

Optimize Your Supply Chain with WIN SOURCE Solutions

- ✓ Global Sourcing Solution
- ✓ Obsolete Management
- ✓ Cost Control Management
- ✓ Shortage Management
- ✓ Alternative Solution
- ✓ Excess Inventory Management