



**THE DATASHEET OF
LM61440AANRJR**



LMG2100R044 100V, 35A GaN Half-Bridge Power Stage

1 Features

- Integrated 4.4mΩ half-bridge GaN FETs and driver
- 90V continuous, 100V pulsed voltage rating
- Package optimized for easy PCB layout
- High slew rate switching with low ringing
- 5V external bias power supply
- Supports 3.3V and 5V input logic levels
- Gate driver capable of up to 10MHz switching
- Excellent propagation delay (33ns typical) and matching (2ns typical)
- Internal bootstrap supply voltage clamping to prevent GaN FET Overdrive
- Supply rail undervoltage for lockout protection
- Low power consumption
- Exposed top QFN package for top-side cooling
- Large GND pad for bottom-side cooling

2 Applications

- Buck, boost, buck-boost converters
- LLC converters
- [Solar inverters](#)
- [Telecom and server power](#)
- [Motor drives](#)
- [Power tools](#)
- [Class-D audio amplifiers](#)

3 Description

The LMG2100R044 device is a 90V continuous, 100V pulsed, 35A half-bridge power stage, with integrated gate-driver and enhancement-mode Gallium Nitride (GaN) FETs. The device consists of two 100V GaN FETs driven by one high-frequency 90V GaN FET driver in a half-bridge configuration.

GaN FETs provide significant advantages for power conversion as they have zero reverse recovery and very small input capacitance C_{ISS} and output capacitance C_{OSS} . All the devices are mounted on a completely bond-wire free package platform with minimized package parasitic elements. The LMG2100R044 device is available in a 5.5mm × 4.5mm lead-free package and can be easily mounted on PCBs.

The TTL logic compatible inputs can support 3.3V and 5V logic levels regardless of the VCC voltage. The proprietary bootstrap voltage clamping technique ensures the gate voltages of the enhancement mode GaN FETs are within a safe operating range.

The device extends advantages of discrete GaN FETs by offering a more user-friendly interface. It is an ideal solution for applications requiring high-frequency, high-efficiency operation in a small form factor.

Package Information

PART NUMBER	PACKAGE ⁽¹⁾	PACKAGE SIZE ⁽²⁾
LMG2100R044	RAR (VQFN, 17)	5.50mm × 4.50mm

(1) For all available packages, see [Section 11](#).

(2) The package size (length × width) is a nominal value and includes pins, where applicable.

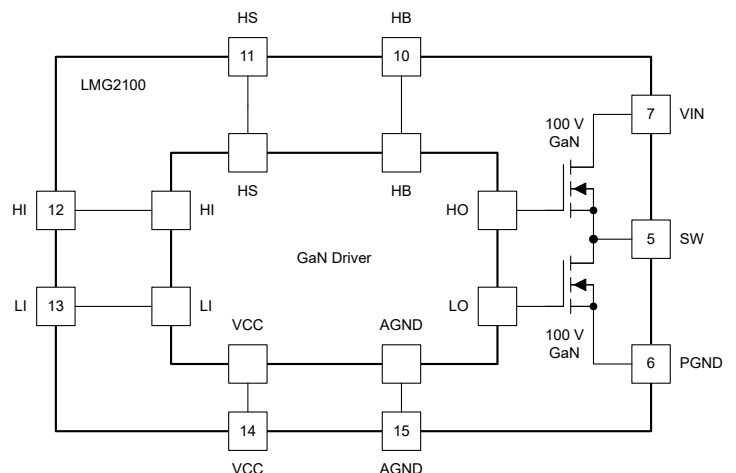

Simplified Block Diagram



Table of Contents

1 Features	1	7.4 Device Functional Modes.....	14
2 Applications	1	8 Application and Implementation	14
3 Description	1	8.1 Application Information.....	14
4 Pin Configuration and Functions	3	8.2 Typical Application.....	14
5 Specifications	4	8.3 Power Supply Recommendations.....	18
5.1 Absolute Maximum Ratings.....	4	8.4 Layout.....	19
5.2 Recommended Operating Conditions.....	4	9 Device and Documentation Support	21
5.3 ESD Ratings.....	4	9.1 Documentation Support.....	21
5.4 Thermal Information.....	5	9.2 Receiving Notification of Documentation Updates....	21
5.5 Electrical Characteristics.....	5	9.3 Support Resources.....	21
5.6 Typical Characteristics.....	7	9.4 Trademarks.....	21
6 Parameter Measurement Information	9	9.5 Electrostatic Discharge Caution.....	21
6.1 Propagation Delay and Mismatch Measurement.....	9	9.6 Glossary.....	21
7 Detailed Description	11	10 Revision History	21
7.1 Overview.....	11	11 Mechanical, Packaging, and Orderable Information	22
7.2 Functional Block Diagram.....	11	11.1 Package Information.....	22
7.3 Feature Description.....	12		

4 Pin Configuration and Functions

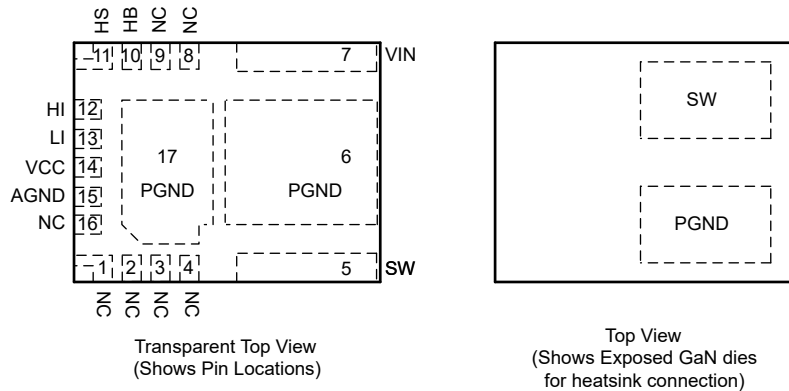

Figure 4-1. RAR Package, 17-Pin VQFN (Top View)

PIN		I/O ⁽¹⁾	DESCRIPTION
NAME	NO.		
NC	1–4, 8, 9, 16	—	Not connected internally. Leave floating.
SW	5	P	Switching node. Internally connected to HS pin.
PGND	6, 17	G	Power ground. Low-side GaN FET source. Internally connected to low-side GaN FET source.
VIN	7	P	Input voltage pin. Internally connected to high-side GaN FET drain.
HB	10	P	High-side gate driver bootstrap rail. Connect bypass capacitor to HS.
HS	11	P	High-side GaN FET source connection.
HI	12	I	High-side gate driver control input.
LI	13	I	Low-side gate driver control input.
VCC	14	P	5V device power supply.
AGND	15	G	Analog ground. Internally connected to low-side GaN FET source.

(1) I = Input, O = Output, G = Ground, P = Power

5 Specifications

5.1 Absolute Maximum Ratings

over operating free-air temperature range (unless otherwise noted)⁽¹⁾

	MIN	MAX	UNIT
VIN to PGND	0	93	V
VIN to PGND (pulsed, 100-ms max duration) ⁽²⁾		100	V
HB to AGND	-0.3	100	V
HS to AGND	-5	93	V
HS to AGND (pulsed, 100-ms max duration) ⁽²⁾		100	V
HI to AGND	-0.3	6	V
LI to AGND	-0.3	6	V
VCC to AGND	-0.3	6	V
HB to HS	-0.3	6	V
HB to VCC	0	93	V
SW to PGND	-5	93	V
IOOUT from SW pin (Continuous), T _J = 25°C		35	A
IOOUT from SW pin (Pulsed, 300 μs), T _J = 25°C		125	A
Junction Temperature, T _J	-40	150	°C
Storage Temperature, T _{stg}	-40	150	°C

- (1) Operation outside the Absolute Maximum Ratings may cause permanent device damage. Absolute Maximum Ratings do not imply functional operation of the device at these or any other conditions beyond those listed under Recommended Operating Conditions. If used outside the Recommended Operating Conditions but within the Absolute Maximum Ratings, the device may not be fully functional, and this may affect device reliability, functionality, performance, and shorten the device lifetime.
- (2) Device can withstand 1000 pulses up to 100V of 100ms duration and less than 1% duty cycle over its lifetime.

5.2 Recommended Operating Conditions

over operating free-air temperature range (unless otherwise noted)

	MIN	NOM	MAX	UNIT
VCC	4.75	5	5.25	V
LI or HI Input	0		6	V
VIN	0		90	V
HS, SW	-5		90	V
HB	V _{HS} + 4		V _{HS} + 5.25	V
HS, SW Slew rate ⁽¹⁾			50	V/ns

- (1) Determined through design and characterization. Not tested in production.

5.3 ESD Ratings

		VALUE	UNIT	
V _(ESD)	Electrostatic Discharge	Human-body model (HBM), per ANSI/ESDA/ JEDEC JS-001 ⁽¹⁾	±500	V
		Charged-device model (CDM), per JEDEC specification JESD22-C101 ⁽²⁾	±500	V

- (1) JEDEC document JEP155 states that 500-V HBM allows safe manufacturing with a standard ESD control process.
- (2) JEDEC document JEP157 states that 250-V CDM allows safe manufacturing with a standard ESD control process.

5.4 Thermal Information

THERMAL METRIC ⁽¹⁾		LMG2100	UNIT
		QFN	
		9 PINS	
R _{θJA}	Junction-to-ambient thermal resistance	29	°C/W
R _{θJC(top)}	Junction-to-case (top) thermal resistance	0.7	
R _{θJB}	Junction-to-board thermal resistance	6.2	°C/W
ψ _{JT}	Junction-to-top characterization parameter	2.8	°C/W
ψ _{JB}	Junction-to-board characterization parameter	5.5	°C/W

(1) For more information about traditional and new thermal metrics, see the *IC Package Thermal Metrics* application report, [SPRA953](#).

5.5 Electrical Characteristics

over operating free-air temperature range (unless otherwise noted)⁽¹⁾

PARAMETER		TEST CONDITIONS	MIN	TYP	MAX	UNIT
SUPPLY CURRENTS						
I _{CC}	VCC Quiescent Current	LI = HI = 0V, VCC = 5V		0.09	0.2	mA
I _{CC}	VCC Quiescent Current	LI=VCC=5V, HI=0V		0.460	4.5	mA
I _{CCO}	Total VCC Operating Current	f = 500 kHz, 50% Duty cycle, V _{IN} = 48V		7.5	15	mA
I _{HB}	HB Quiescent Current	LI = HI = 0V, VCC = 5V, HB-HS = 4.6V		0.1	0.2	mA
I _{HB}	HB Quiescent Current	LI=0V, HI=VCC=5V, HB-HS=4.6V		0.23	4.5	mA
I _{HBO}	HB Operating Current	f = 500 kHz, 50% Duty cycle, VCC = 5V, HB-HS = 4.6V		3.5	7.5	mA
INPUT PINS						
V _{IH}	High-Level Input Voltage Threshold	Rising Edge	1.87	2.06	2.22	V
V _{IL}	Low-Level Input Voltage Threshold	Falling Edge	1.48	1.66	1.76	V
V _{HYS}	Hysteresis between rising and falling threshold			400		mV
R _I	Input pull down resistance		100	200	300	kΩ
UNDER VOLTAGE PROTECTION						
V _{CCR}	VCC Rising edge threshold	Rising	3.2	3.8	4.5	V
V _{CCF}	VCC Falling edge threshold		3.0	3.6	4.3	V
V _{CC(hyst)}	VCC UVLO threshold hysteresis			210		mV
V _{HBR}	HB Rising edge threshold	Rising	2.5	3.2	3.9	V
V _{HBF}	HB Falling edge threshold		2.3	3.0	3.7	V
V _{HB(hyst)}	HB UVLO threshold hysteresis			200		mV
BOOTSTRAP DIODE						
V _{DL}	Low-Current forward voltage	I _{HB-HS} = 100μA		0.45	0.7	V
V _{DH}	High current forward voltage	I _{HB-HS} = 100mA		0.9	1.0	V
R _D	Dynamic Resistance	I _{HB-HS} = 100mA		1.85		Ω
	HB-HS Clamp	Regulation Voltage	4.65	5	5.2	V
t _{BS}	Bootstrap diode reverse recovery time	I _F = 100 mA, I _R = 100 mA		40		ns
Q _{RR}	Bootstrap diode reverse recovery charge	V _{VIN} = 50 V		2		nC
POWER STAGE						
R _{DS(ON)HS}	High-side GaN FET on-resistance	LI=0V, HI=VCC=5V, HB-HS=5V, I(VIN-SW)=16A, T _J = 25°C		4.4	6.0	mΩ
R _{DS(ON)LS}	Low-side GaN FET on-resistance	LI=VCC=5V, HI=0V, HB-HS=5V, I(SW-PGND)=16A, T _J = 25°C		4.3	5.7	mΩ
V _{SD}	GaN 3rd quadrant conduction drop	I _{SD} = 500 mA, V _{IN} floating, VCC = 5 V, HI = LI = 0V		1.5		V
I _{L-VIN-SW}	Leakage from VIN to SW when the high-side GaN FET and low-side GaN FET are off	VIN = 80V, SW=0, HI = LI = 0V, VCC = 5V, T _J =25°C		4	80	μA

over operating free-air temperature range (unless otherwise noted)⁽¹⁾

PARAMETER		TEST CONDITIONS	MIN	TYP	MAX	UNIT
$I_{L-SW-GND}$	Leakage from SW to GND when the high-side GaN FET and low-side GaN FET are off	SW = 80V, HI = LI = 0V, VCC = 5V, T _J =25°C		4	80	μA
C_{ISS}	Input Capacitance of high side or low side HEMT	V _{DS} =50V, V _{GS} = 0V (HI = LI = 0V)		1046	1348	pF
C_{OSS}	Output Capacitance of high-side GaN FET or low-side GaN FET	V _{DS} =50V, V _{GS} = 0V (HI = LI = 0V)		364	478	pF
$C_{OSS(ER)}$	Output Capacitance of high-side GaN FET or low-side GaN FET - Energy Related	V _{DS} =0 to 50V, V _{GS} = 0V (HI = LI = 0V)		441		pF
$C_{OSS(TR)}$	Output Capacitance of high-side GaN FET or low-side GaN FET - Time Related	V _{DS} =0 to 50V, V _{GS} = 0V (HI = LI = 0V)		548		pF
C_{WELL}	HV-Well Capacitance (SW to PGND)	V _{IN} =V _{SW} =50V, HI = LI = 0V		30		pF
C_{RSS}	Reverse Transfer Capacitance of high side or low side HEMT	V _{DS} =50V, V _{GS} = 0V (HI = LI = 0V)		2.9		pF
Q_G	Total Gate Charge of high side or low side HEMT	V _{DS} =50V, I _D = 16A, V _{GS} = 5V		7.3	9.3	nC
Q_{GD}	Gate to Drain Charge of high side or low side HEMT	V _{DS} =50V, I _D = 16A		0.7		nC
Q_{GS}	Gate to Source Charge of high side or low side HEMT	V _{DS} =50V, I _D = 16A		2.8		nC
Q_{OSS}	Output Charge (sum of high side HEMT, low side HEMT and gate-driver HV-Well charge)	V _{DS} =50V, I _D = 16A		55	80	nC
Q_{RR}	Source to Drain Reverse Recovery Charge	Not including internal driver bootstrap diode		0		nC
t_{HIPLH}	Propagation delay: HI Rising ⁽²⁾	LI=0V, VCC=5V, HB-HS=5V, VIN=48V		35	50	ns
t_{HIPHL}	Propagation delay: HI Falling ⁽²⁾	LI=0V, VCC=5V, HB-HS=5V, VIN=48V		33	50	ns
t_{LPLH}	Propagation delay: LI Rising ⁽²⁾	HI=0V, VCC=5V, HB-HS=5V, VIN=48V		35	50	ns
t_{LPHL}	Propagation delay: LI Falling ⁽²⁾	HI=0V, VCC=5V, HB-HS=5V, VIN=48V		33	50	ns
t_{MON}	Delay Matching: LI high & HI low ⁽²⁾			2	8.0	ns
t_{MOFF}	Delay Matching: LI low & HI high ⁽²⁾			2	8.0	ns
t_{PW}	Minimum Input Pulse Width that Changes the Output			10		ns

(1) Parameters that show only a typical value are determined by design and may not be tested in production

(2) See *Propagation Delay and Mismatch Measurement* section

5.6 Typical Characteristics

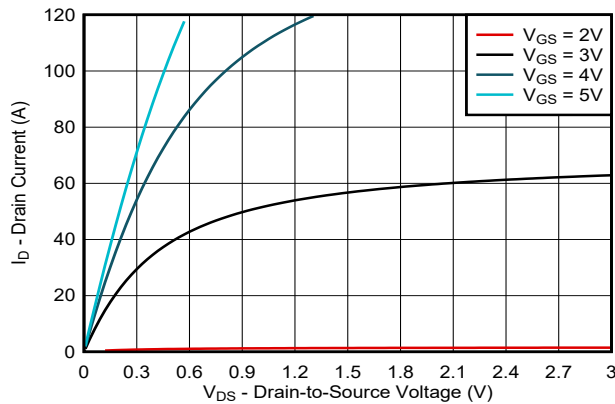

Figure 5-1. Typical Output Characteristics at 25°C

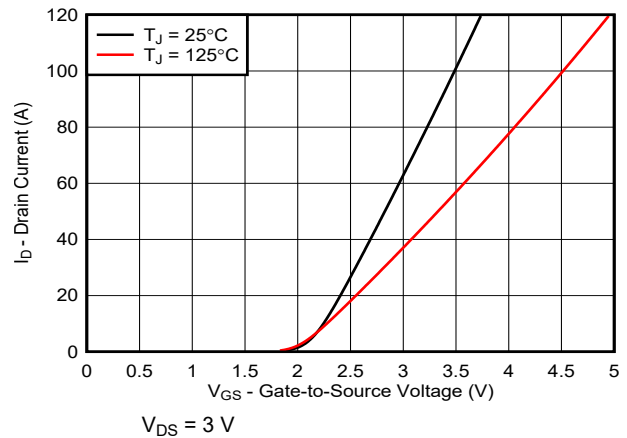

Figure 5-2. Typical Transfer Characteristics

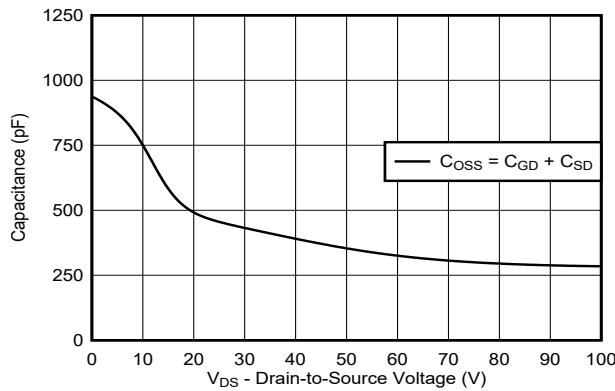

Figure 5-3. Typical Capacitance (Linear Scale)

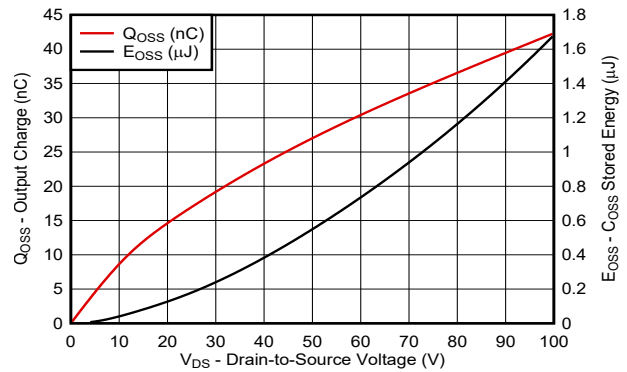

Figure 5-4. Typical Output Charge and C_{OSS} Stored Energy

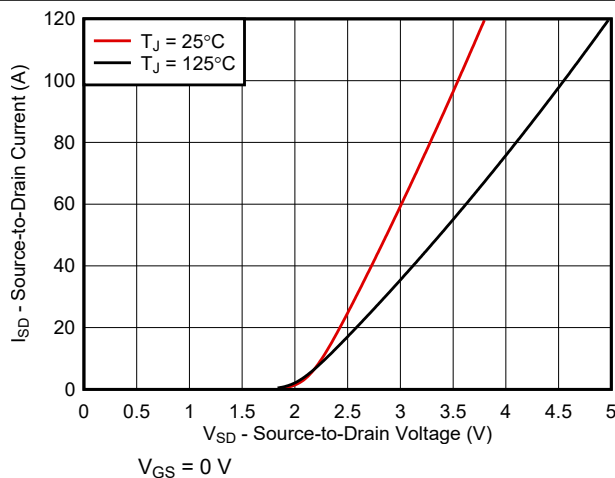

Figure 5-5. Reverse Drain-Source Characteristics

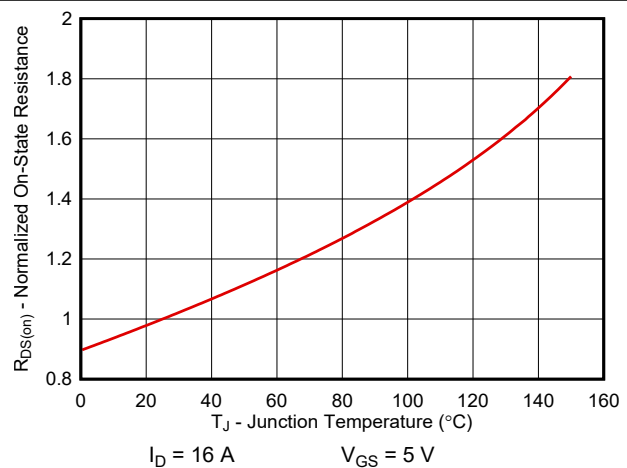

Figure 5-6. Normalized On-State Resistance vs. Temperature

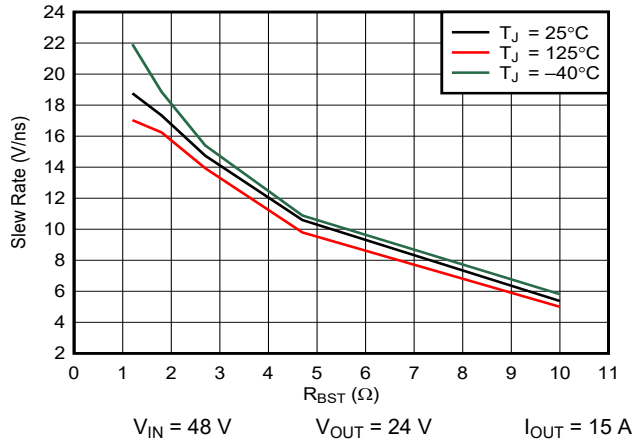

Figure 5-7. Slew Rate Control for a Buck Converter using R_{BST}

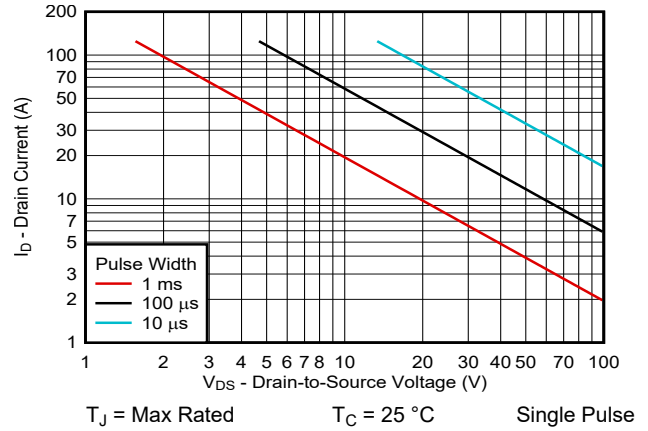

Figure 5-8. Safe Operating Area

6 Parameter Measurement Information

6.1 Propagation Delay and Mismatch Measurement

Figure 6-1 shows the typical test setup used to measure the propagation mismatch. As the gate drives are not accessible, pullup and pulldown resistors in this test circuit are used to indicate when the low-side GaN FET turns ON and the high-side GaN FET turns OFF and vice versa to measure the t_{MON} and t_{MOFF} parameters. Resistance values used in this circuit for the pullup and pulldown resistors are in the order of 1 k Ω ; the current sources used are 2 A.

Figure 6-2 through Figure 6-5 show propagation delay measurement waveforms. For turnon propagation delay measurements, the current sources are not used. For turnoff time measurements, the current sources are set to 2 A, and a voltage clamp limit is also set, referred to as $V_{IN(CLAMP)}$. When measuring the high-side component turnoff delay, the current source across the high-side FET is turned on, the current source across the low-side FET is off, HI transitions from high-to-low, and output voltage transitions from V_{IN} to $V_{IN(CLAMP)}$. Similarly, for low-side component turnoff propagation delay measurements, the high-side component current source is turned off, and the low-side component current source is turned on, LI transitions from high to low and the output transitions from GND potential to $V_{IN(CLAMP)}$. The time between the transition of LI and the output change is the propagation delay time.

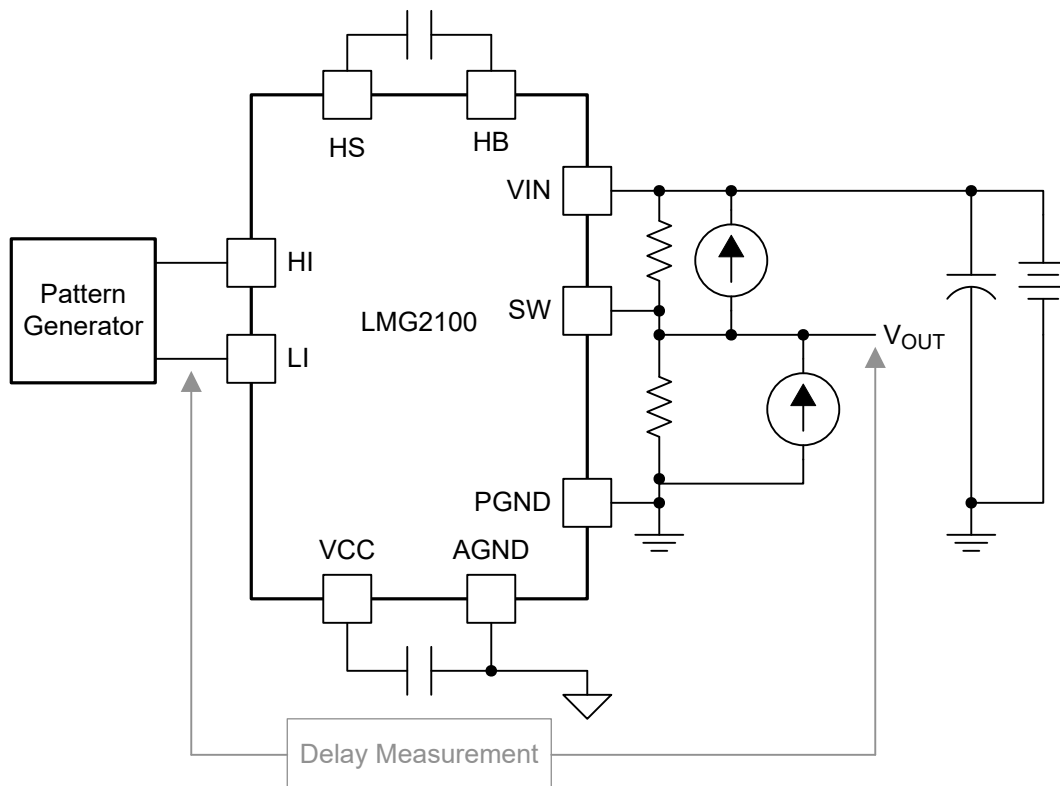

Figure 6-1. Propagation Delay and Propagation Mismatch Measurement

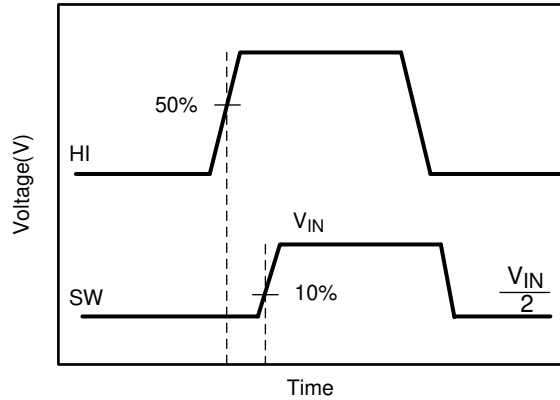

Figure 6-2. High-Side Gate Driver Turnon

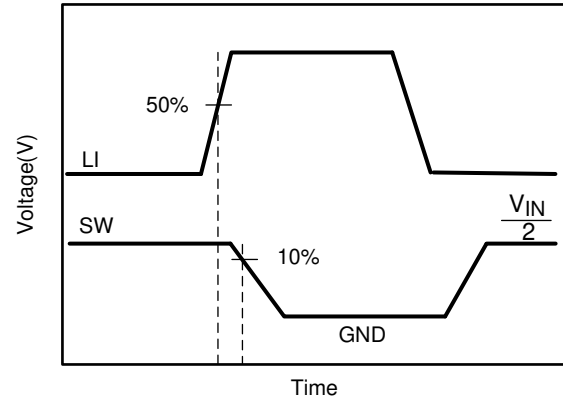

Figure 6-3. Low-Side Gate Driver Turnon

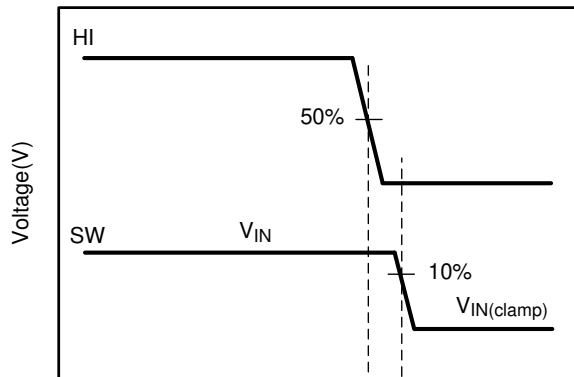

Figure 6-4. High-Side Gate Driver Turnoff

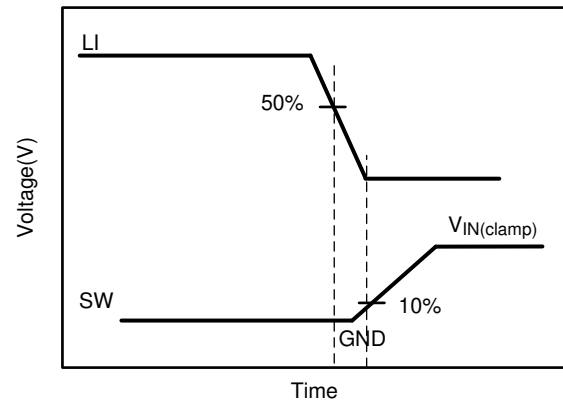

Figure 6-5. Low-Side Gate Driver Turnoff

7 Detailed Description

7.1 Overview

Figure 7-1 shows the LMG2100R044, half-bridge, GaN power stage with highly integrated high-side and low-side gate drivers, which includes built-in UVLO protection circuitry and an overvoltage clamp circuitry. The clamp circuitry limits the bootstrap refresh operation to ensure that the high-side gate driver overdrive does not exceed 5.4 V. The device integrates two, 4.4-mΩ GaN FETs in a half-bridge configuration. The device can be used in many isolated and non-isolated topologies allowing very simple integration. The package is designed to minimize the loop inductance while keeping the PCB design simple. The drive strengths for turnon and turnoff are optimized to ensure high voltage slew rates without causing any excessive ringing on the gate or power loop.

7.2 Functional Block Diagram

Figure 7-1 shows the functional block diagram of the LMG2100R044 device with integrated high-side and low-side GaN FETs.

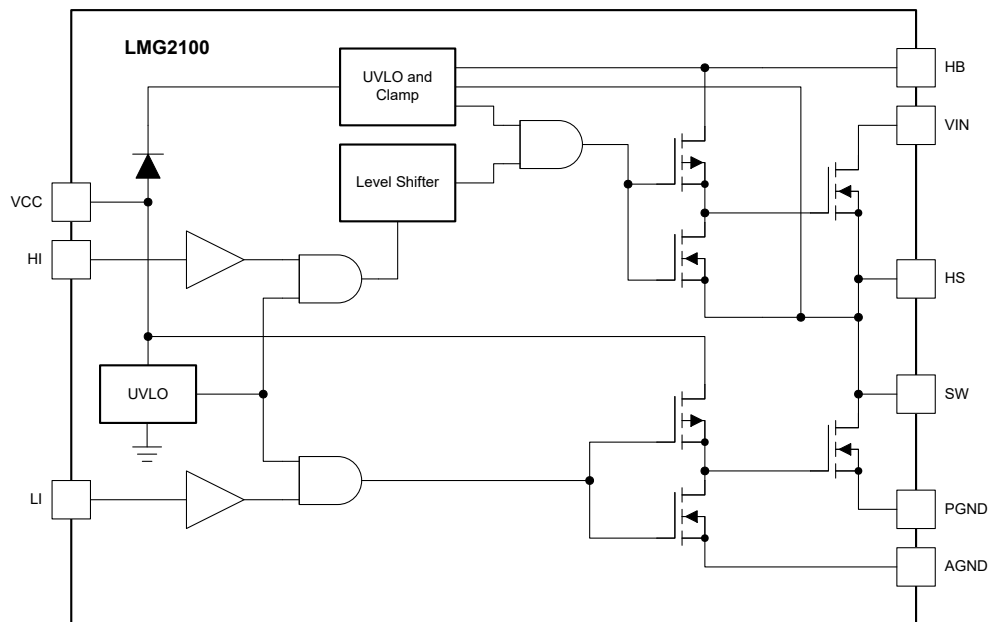

Figure 7-1. Functional Block Diagram

7.3 Feature Description

The LMG2100R044 device brings ease of designing high power density boards without the need for underfill while maintaining creepage and clearance requirements. The propagation delays between the high-side gate driver and low-side gate driver are matched to allow very tight control of dead time. Controlling the dead time is critical in GaN-based applications to maintain high efficiency. HI and LI can be independently controlled to minimize the third quadrant conduction of the low-side FET for hard switched buck converters. A very small propagation mismatch between the HI and LI to the drivers for both the falling and rising thresholds ensures dead times of < 10 ns. Co-packaging the GaN FET half-bridge with the driver ensures minimized common source inductance. This minimized inductance has a significant performance impact on hard-switched topologies.

The built-in bootstrap circuit with clamp prevents the high-side gate drive from exceeding the GaN FETs maximum gate-to-source voltage (V_{gs}) without any additional external circuitry. The built-in driver has an undervoltage lockout (UVLO) on the VCC and bootstrap (HB-HS) rails. When the voltage is below the UVLO threshold voltage, the device ignores both the HI and LI signals to prevent the GaN FETs from being partially turned on. Below UVLO, if there is sufficient voltage ($V_{VCC} > 2.5\text{ V}$), the driver actively pulls the high-side and low-side gate driver output low. The UVLO threshold hysteresis of 200 mV prevents chattering and unwanted turnon due to voltage spikes. Use an external VCC bypass capacitor with a value of 0.1 μF or higher. TI recommends a size of 0402 to minimize trace length to the pin. Place the bypass and bootstrap capacitors as close as possible to the device to minimize parasitic inductance.

7.3.1 Control Inputs

The LMG2100R044's inputs pins are independently controlled with TTL input thresholds and can support 3.3-V and 5-V logic levels regardless of the VCC voltage.

In order to allow flexibility to optimize deadtime according to design needs, the LMG2100R044 does not implement an overlap protection functionality. If both HI and LI are asserted, both the high-side and low-side GaN FETs are turned on. Careful consideration must be applied to the control inputs in order to avoid a shoot-through condition.

7.3.2 Start-up and UVLO

The LMG2100R044 has an UVLO on both the VCC and HB (bootstrap) supplies. When the VCC voltage is below the threshold voltage of 3.8 V, both the HI and LI inputs are ignored, to prevent the GaN FETs from being partially turned on. Also, if there is insufficient VCC voltage, the UVLO actively pulls the high- and low-side GaN FET gates low. When the HB to HS bootstrap voltage is below the UVLO threshold of 3.2 V, only the high-side GaN FET gate is pulled low. Both UVLO threshold voltages have 200 mV of hysteresis to avoid chattering.

Table 7-1. V_{CC} UVLO Feature Logic Operation

CONDITION ($V_{HB}-V_{HS} > V_{HBR}$ for all cases below)	HI	LI	SW
$V_{CC} - V_{AGND} < V_{CCR}$ during device start-up	H	L	Hi-Z
$V_{CC} - V_{AGND} < V_{CCR}$ during device start-up	L	H	Hi-Z
$V_{CC} - V_{AGND} < V_{CCR}$ during device start-up	H	H	Hi-Z
$V_{CC} - V_{AGND} < V_{CCR}$ during device start-up	L	L	Hi-Z
$V_{CC} - V_{AGND} < V_{CCF}$ after device start-up	H	L	Hi-Z
$V_{CC} - V_{AGND} < V_{CCF}$ after device start-up	L	H	Hi-Z
$V_{CC} - V_{AGND} < V_{CCF}$ after device start-up	H	H	Hi-Z
$V_{CC} - V_{AGND} < V_{CCF}$ after device start-up	L	L	Hi-Z

Table 7-2. V_{HB-HS} UVLO Feature Logic Operation

CONDITION ($V_{CC} > V_{CCR}$ for all cases below)	HI	LI	SW
$V_{HB}-V_{HS} < V_{HBR}$ during device start-up	H	L	Hi-Z
$V_{HB}-V_{HS} < V_{HBR}$ during device start-up	L	H	PGND
$V_{HB}-V_{HS} < V_{HBR}$ during device start-up	H	H	PGND

Table 7-2. V_{HB-HS} UVLO Feature Logic Operation (continued)

CONDITION ($V_{CC} > V_{CCR}$ for all cases below)	HI	LI	SW
$V_{HB}-V_{HS} < V_{HBR}$ during device start-up	L	L	Hi-Z
$V_{HB}-V_{HS} < V_{HBF}$ after device start-up	H	L	Hi-Z
$V_{HB}-V_{HS} < V_{HBF}$ after device start-up	L	H	PGND
$V_{HB}-V_{HS} < V_{HBF}$ after device start-up	H	H	PGND
$V_{HB}-V_{HS} < V_{HBF}$ after device start-up	L	L	Hi-Z

7.3.3 Bootstrap Supply Voltage Clamping

The high-side bias voltage is generated using a bootstrap technique and is internally clamped at 5 V (typical). This clamp prevents the gate voltage from exceeding the maximum gate-source voltage rating of the enhancement-mode GaN FETs.

7.3.4 Level Shift

The level-shift circuit is the interface from the high-side input HI to the high-side driver stage, which is referenced to the switch node (HS). The level shift allows control of the high-side GaN FET gate driver output, which is referenced to the HS pin and provides excellent delay matching with the low-side driver.

7.4 Device Functional Modes

The LMG2100R044 operates in normal mode and UVLO mode. See [Section 7.3.2](#) for information on UVLO operation mode. In the normal mode, the output state is dependent on the states of the HI and LI pins. [Table 7-3](#) lists the output states for different input pin combinations. Note that when both HI and LI are asserted, both GaN FETs in the power stage are turned on. Careful consideration must be applied to the control inputs in order to avoid this state, as it will result in a shoot-through condition, which can permanently damage the device.

Table 7-3. Truth Table

HI	LI	HIGH-SIDE GaN FET	LOW-SIDE GaN FET	SW
L	L	OFF	OFF	Hi-Z
L	H	OFF	ON	PGND
H	L	ON	OFF	VIN
H	H	ON	ON	---

8 Application and Implementation

Note

Information in the following applications sections is not part of the TI component specification, and TI does not warrant its accuracy or completeness. TI's customers are responsible for determining suitability of components for their purposes. Customers should validate and test their design implementation to confirm system functionality.

8.1 Application Information

The LMG2100R044 GaN power stage is a versatile building block for various types of high-frequency, switch-mode power applications. The high-performance gate driver IC integrated in the package helps minimize the parasitics and results in extremely fast switching of the GaN FETs. The device design is highly optimized for synchronous buck converters and other half-bridge configurations.

8.2 Typical Application

[Figure 8-1](#) shows a synchronous buck converter application with VCC connected to a 5-V supply. It is critical to optimize the power loop (loop impedance from VIN capacitor to PGND). Having a high power loop inductance causes significant ringing in the SW node and also causes the associated power loss. The LMG2100R044 has VIN and PGND pins next to each other. This enables the VIN capacitor to be placed very close to LMG2100R044 on the top layer of the PCB, minimizing power loop inductance.

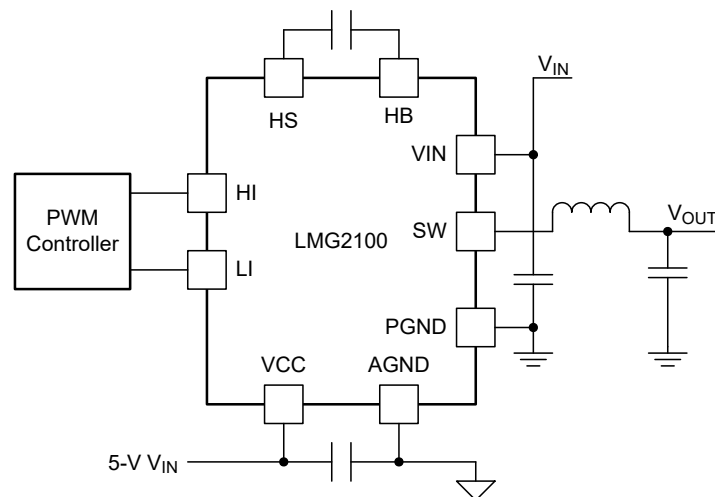

Figure 8-1. Typical Connection Diagram For a Synchronous Buck Converter

8.2.1 Design Requirements

When designing a synchronous buck converter application that incorporates the LMG2100R044 power stage, some design considerations must be evaluated first to make the most appropriate selection. Among these considerations are the input voltages, passive components, operating frequency, and controller selection. [Table 8-1](#) shows some sample values for a typical application. See [Section 8.3](#), [Section 8.4](#), and [Section 8.2.2.4](#) for other key design considerations for the LMG2100R044.

Table 8-1. Design Parameters

PARAMETER	SAMPLE VALUE
Half-bridge input supply voltage, V_{IN}	48 V
Output voltage, V_{OUT}	12 V
Output current	8 A
$V_{HB}-V_{HS}$ bootstrap capacitor	0.1 μ F, X5R
Switching frequency	1 MHz
Dead time	8 ns
Inductor	4.7 μ H
Controller	LM5148

8.2.2 Detailed Design Procedure

This procedure outlines the design considerations of LMG2100R044 in a synchronous buck converter. For additional design help, see [Section 9.1.1](#).

8.2.2.1 V_{CC} Bypass Capacitor

The V_{CC} bypass capacitor provides the gate charge for the low-side and high-side transistors and to absorb the reverse recovery charge of the bootstrap diode. The required bypass capacitance can be calculated with [Equation 1](#).

$$C_{VCC} = (2 \times Q_G + Q_{RR}) / \Delta V \quad (1)$$

Q_G is the individual and equal gate charge of the high-side and low-side GaN FETs. Q_{RR} is the reverse recovery charge of the bootstrap diode. ΔV is the maximum allowable voltage drop across the bypass capacitor. A 0.1- μ F or larger value, good-quality, ceramic capacitor is recommended. Place the bypass capacitor as close as possible to the VCC and AGND pins of the device to minimize the parasitic inductance.

8.2.2.2 Bootstrap Capacitor

The bootstrap capacitor provides the gate charge for the high-side gate drive, dc bias power for HB UVLO circuit, and the reverse recovery charge of the bootstrap diode. The required bypass capacitance can be calculated using [Equation 2](#).

$$C_{BST} = (Q_G + Q_{RR} + I_{HB} \cdot t_{ON(max)}) / \Delta V \quad (2)$$

where

- I_{HB} is the quiescent current of the high-side gate driver
- $t_{ON(max)}$ is the maximum on-time period of the high-side gate driver
- Q_{RR} is the reverse recovery charge of the bootstrap diode
- Q_G is the gate charge of the high-side GaN FET
- ΔV is the permissible ripple in the bootstrap capacitor (< 100 mV, typical)

A 0.1- μ F, 16-V, 0402 ceramic capacitor is suitable for most applications. Place the bootstrap capacitor as close as possible to the HB and HS pins.

8.2.2.3 Slew Rate Control

Figure 8-2 shows a switching application where the slew rate on the switch node may be controlled by using resistors R_{VCC} and R_{BST} . R_{VCC} may be used to slow down the turn-on of the Low Side GaN FET (for example, in a buck converter), and R_{BST} may be used to slow down the turn-on of the High Side GaN FET (for example, in a boost converter). Using these resistors allows the system engineer to optimize the tradeoff between higher efficiency (faster slew rates) and lower ringing (slower slew rates).

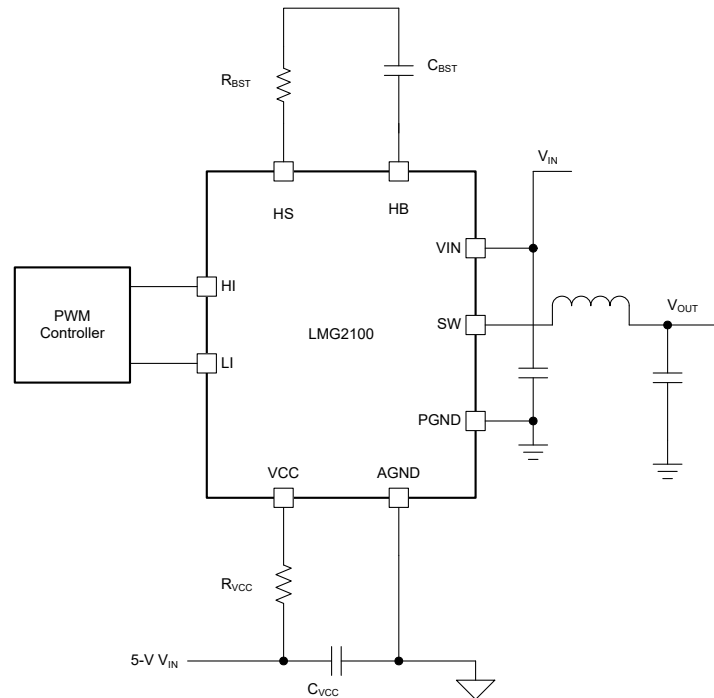

Figure 8-2. Slew Rate Control with R_{BST} and R_{VCC} Resistors

8.2.2.4 Power Dissipation

Ensure that the power loss in the driver and the GaN FETs is maintained below the maximum power dissipation limit of the package at the operating temperature. The smaller the power loss in the driver and the GaN FETs, the higher the maximum operating frequency that can be achieved in the application. The total power dissipation of the LMG2100R044 device is the sum of the gate driver losses, the bootstrap diode power loss and the switching and conduction losses in the FETs.

The gate driver losses are incurred by charge and discharge of the capacitive load. It can be approximated using [Equation 3](#).

$$P = 2 \times Q_G \times V_{CC} \times f_{SW} \quad (3)$$

where

- Q_G is the gate charge
- V_{CC} is the bias supply
- f_{SW} is the switching frequency

There are some additional losses in the gate drivers due to the internal CMOS stages used to buffer the outputs.

The bootstrap diode power loss is the sum of the forward bias power loss that occurs while charging the bootstrap capacitor and the reverse bias power loss that occurs during reverse recovery. Because each of these events happens once per cycle, the diode power loss is proportional to the operating frequency. Higher input voltages (V_{IN}) to the half bridge also result in higher reverse recovery losses.

The power losses due to the GaN FETs can be divided into conduction losses and switching losses. Conduction losses are resistive losses and can be calculated using [Equation 4](#).

$$P_{COND} = \left[(I_{RMS(HS)})^2 \times R_{DS(on)HS} \right] + \left[(I_{RMS(LS)})^2 \times R_{DS(on)LS} \right] \quad (4)$$

where

- $R_{DS(on)HS}$ is the high-side GaN FET on-resistance
- $R_{DS(on)LS}$ is the low-side GaN FET on-resistance
- $I_{RMS(HS)}$ is the high-side GaN FET RMS current
- $I_{RMS(LS)}$ and low-side GaN FET RMS current

The switching losses can be computed to a first order using [Equation 5](#), where t_{TR} can be approximated by dividing V_{IN} by 25V/ns, which is a conservative estimate of the switched node slew rate.

$$P_{SW} = V_{IN} \times I_{OUT} \times t_{TR} \times f_{SW} + V_{IN} \times V_{IN} \times C_{OSS(ER)} \times f_{SW} \quad (5)$$

where

- t_{TR} is sum of the switch node transition times from ON to OFF and from OFF to ON
- $C_{OSS(ER)}$ is the output capacitance of each GaN FET

Note that the low-side FET does not suffer from this loss. The third quadrant loss in the low-side device is ignored in this first order loss calculation.

As described previously, switching frequency has a direct effect on device power dissipation. Although the gate driver of the LMG2100R044 device is capable of driving the GaN FETs at frequencies up to 10 MHz, careful consideration must be applied to ensure that the running conditions for the device meet the recommended operating temperature specification. Specifically, hard-switched topologies tend to generate more losses and self-heating than soft-switched applications.

The sum of the driver loss, the bootstrap diode loss, and the switching and conduction losses in the GaN FETs is the total power loss of the device. Careful board layout with an adequate amount of thermal vias close to the

power pads (VIN and PGND) allows optimum power dissipation from the package. A top-side mounted heat sink with airflow can also improve the package power dissipation.

8.2.3 Application Curves

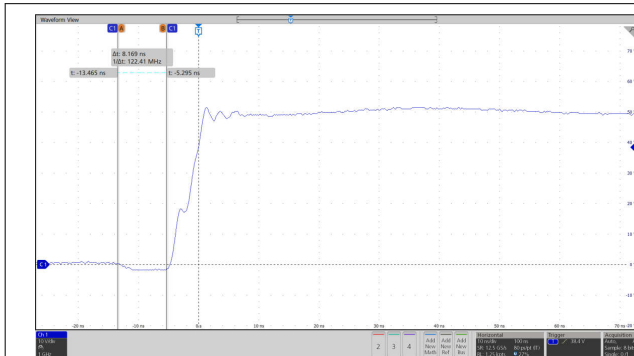

Figure 8-3. SW Node Behavior Showing the Dead Time and Rise Time for a Buck Converter with $R_{BST}=2.7 \Omega$

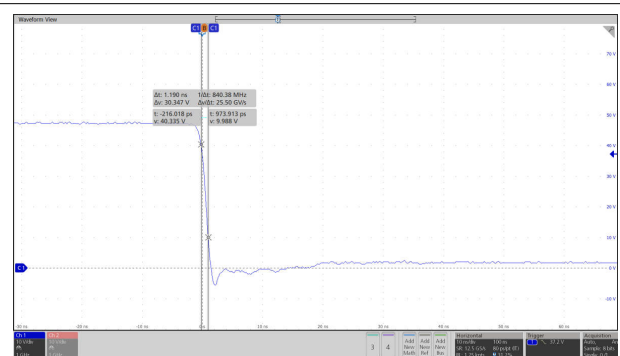

Figure 8-4. SW Node Behavior Showing the Fall Time for a Buck Converter

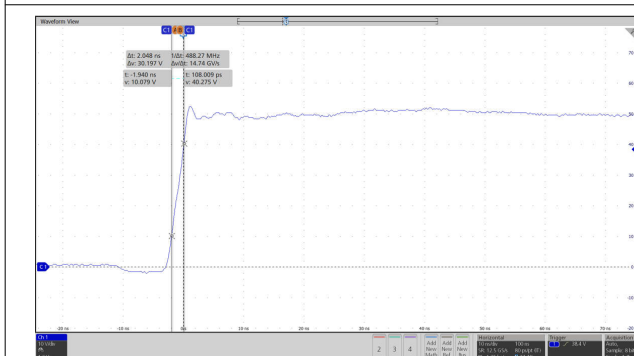

Figure 8-5. SW Node Behavior Showing the Rise Time for a Buck Converter with HB-HS supplied externally and $R_{BST}=2.7 \Omega$

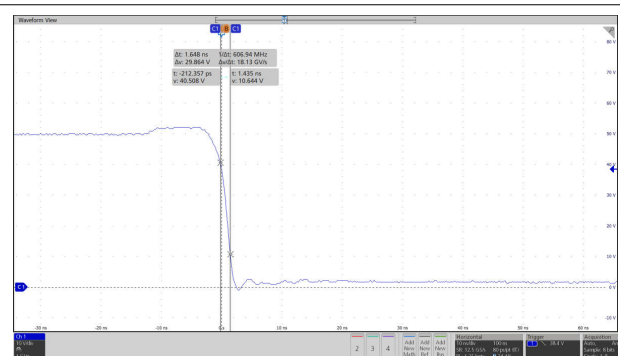

Figure 8-6. SW Node Behavior Showing the Fall Time for a Boost Converter $R_{VCC}=2.7 \Omega$

8.3 Power Supply Recommendations

The recommended bias supply voltage range for LMG2100R044 is from 4.75 V to 5.25 V. Note that the gate voltage of the low-side GaN FET is not clamped internally. Hence, it is important to keep the VCC bias supply within the recommended operating range to prevent exceeding the low-side GaN transistor gate breakdown voltage.

The UVLO protection feature also involves a hysteresis function. This means that once the device is operating in normal mode, if the VCC voltage drops, the device continues to operate in normal mode as far as the voltage drop does not exceeds the hysteresis specification, $V_{CC(hyst)}$. If the voltage drop is more than hysteresis specification, the device shuts down. Therefore, while operating at or near the 4.5 V range, the voltage ripple on the auxiliary power supply output must be smaller than the hysteresis specification of LMG2100R044 to avoid triggering device-shutdown.

Place a local bypass capacitor between the VCC and AGND pins. This capacitor must be located as close as possible to the device. A low ESR, ceramic surface-mount capacitor is recommended. TI recommends using 2 capacitors across VCC and AGND: a 100 nF ceramic surface-mount capacitor for high frequency filtering placed very close to VCC and AGND pin, and another surface-mount capacitor, 220 nF to 10 μ F, for IC bias requirements.

8.4 Layout

8.4.1 Layout Guidelines

To maximize the efficiency benefits of fast switching, it is extremely important to optimize the board layout such that the power loop impedance is minimal. When using a multilayer board (more than 2 layers), power loop parasitic impedance is minimized by having the return path to the input capacitor (between VIN and PGND), small and directly underneath the first layer as shown in [Figure 8-7](#) and [Figure 8-8](#). Loop inductance is reduced due to flux cancellation as the return current is directly underneath and flowing in the opposite direction.

Insufficient attention to the above power loop layout guidelines can result in excessive overshoot and undershoot on the switch node.

It is also critical that the VCC capacitors and the bootstrap capacitors are as close as possible to the device and in the first layer. Carefully consider the AGND connection of LMG2100R044 device. It must NOT be directly connected to PGND so that PGND noise does not directly shift AGND and cause spurious switching events due to noise injected in HI and LI signals.

Refer [LMG2100 EVM](#) for an actual layout based on these recommendations.

8.4.2 Layout Examples

Placements shown in [Figure 8-7](#) and in the cross section of [Figure 8-8](#) show the suggested placement of the device with respect to sensitive passive components, such as VIN, bootstrap capacitors (HS and HB) and VSS capacitors. Use appropriate spacing in the layout to reduce creepage and maintain clearance requirements in accordance with the application pollution level. Inner layers if present can be more closely spaced due to negligible pollution.

The layout must be designed to minimize the capacitance at the SW node. Use as small an area of copper as possible to connect the device SW pin to the inductor, or transformer, or other output load. Furthermore, ensure that the ground plane or any other copper plane has a cutout so that there is no overlap with the SW node, as this would effectively form a capacitor on the printed circuit board. Additional capacitance on this node reduces the advantages of the advanced packaging approach of the LMG2100R044 and may result in reduced performance.

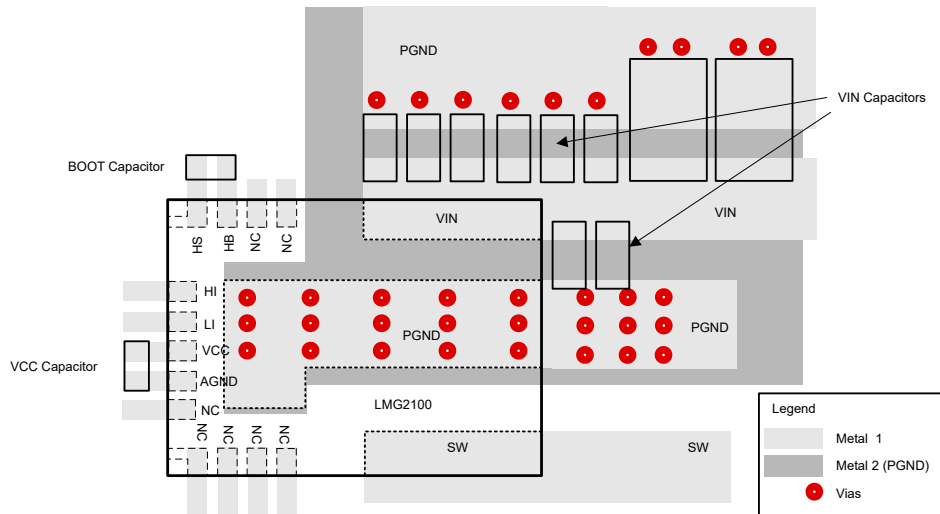

Figure 8-7. External Component Placement (Multi-layer PCB)

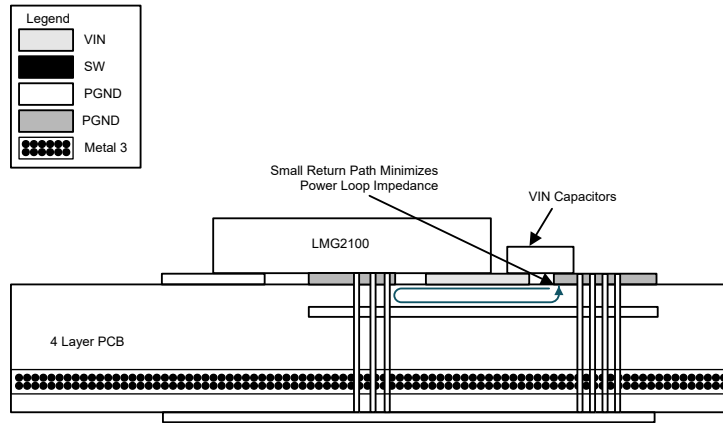

Figure 8-8. Four-Layer Board Cross Section With Return Path Directly Underneath for Power Loop

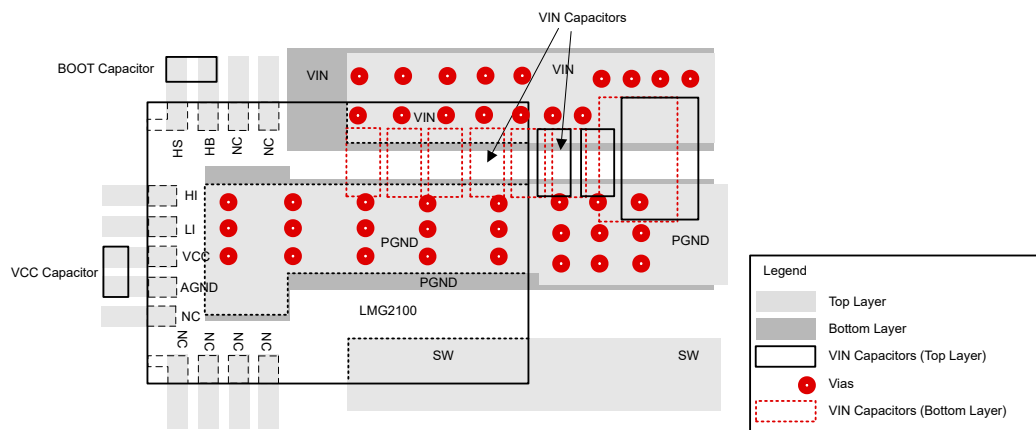

Figure 8-9. External Component Placement (Double Layer PCB)

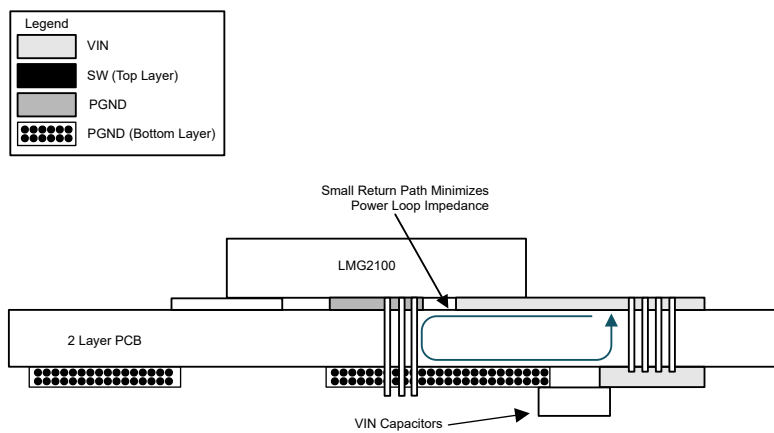

Figure 8-10. Two-Layer Board Cross Section With Return Path

Two-layer boards are not recommended for use with LMG2100R044 device due to the larger power loop inductance. However, if design considerations allow only two board layers, place the input decoupling capacitors immediately behind the device on the back-side of the board to minimize loop inductance. [Figure 8-9](#) and [Figure 8-10](#) show a layout example for two-layer boards.

9 Device and Documentation Support

9.1 Documentation Support

9.1.1 Related Documentation

[Layout Guidelines for LMG2100R044 GaN Power Stage Module](#)

[Using the LMG2100R044: GaN Half-Bridge Power Module Evaluation Module](#)

9.2 Receiving Notification of Documentation Updates

To receive notification of documentation updates, navigate to the device product folder on ti.com. In the upper right corner, click on *Alert me* to register and receive a weekly digest of any product information that has changed. For change details, review the revision history included in any revised document.

9.3 Support Resources

[TI E2E™ support forums](#) are an engineer's go-to source for fast, verified answers and design help — straight from the experts. Search existing answers or ask your own question to get the quick design help you need.

Linked content is provided "AS IS" by the respective contributors. They do not constitute TI specifications and do not necessarily reflect TI's views; see TI's [Terms of Use](#).

9.4 Trademarks

TI E2E™ is a trademark of Texas Instruments.
All trademarks are the property of their respective owners.

9.5 Electrostatic Discharge Caution



This integrated circuit can be damaged by ESD. Texas Instruments recommends that all integrated circuits be handled with appropriate precautions. Failure to observe proper handling and installation procedures can cause damage.

ESD damage can range from subtle performance degradation to complete device failure. Precision integrated circuits may be more susceptible to damage because very small parametric changes could cause the device not to meet its published specifications.

9.6 Glossary

[TI Glossary](#) This glossary lists and explains terms, acronyms, and definitions.

10 Revision History

NOTE: Page numbers for previous revisions may differ from page numbers in the current version.

Changes from Revision A (February 2024) to Revision B (March 2024)	Page
• Changed the document status From: <i>Advance Information</i> To: <i>Production Data</i>	1

11 Mechanical, Packaging, and Orderable Information

The following pages include mechanical, packaging, and orderable information. This information is the most current data available for the designated devices. This data is subject to change without notice and revision of this document. For browser-based versions of this data sheet, refer to the left-hand navigation.

11.1 Package Information

The LMG2100R044 device package is rated as an MSL3 package (Moisture Sensitivity Level 3). Refer to application report [AN-2029 Handling and Process Recommendations](#) for specific handling and process recommendations of an MSL3 package.

PACKAGING INFORMATION

Orderable part number	Status (1)	Material type (2)	Package Pins	Package qty Carrier	RoHS (3)	Lead finish/ Ball material (4)	MSL rating/ Peak reflow (5)	Op temp (°C)	Part marking (6)
LMG2100R044RARR	Active	Production	VQFN-FCRLF (RAR) 16	2500 LARGE T&R	Yes	NIPDAU	Level-2-260C-1 YEAR	-40 to 125	G2100
LMG2100R044RARR.A	Active	Production	VQFN-FCRLF (RAR) 16	2500 LARGE T&R	Yes	NIPDAU	Level-2-260C-1 YEAR	-40 to 125	G2100

(1) **Status:** For more details on status, see our [product life cycle](#).

(2) **Material type:** When designated, preproduction parts are prototypes/experimental devices, and are not yet approved or released for full production. Testing and final process, including without limitation quality assurance, reliability performance testing, and/or process qualification, may not yet be complete, and this item is subject to further changes or possible discontinuation. If available for ordering, purchases will be subject to an additional waiver at checkout, and are intended for early internal evaluation purposes only. These items are sold without warranties of any kind.

(3) **RoHS values:** Yes, No, RoHS Exempt. See the [TI RoHS Statement](#) for additional information and value definition.

(4) **Lead finish/Ball material:** Parts may have multiple material finish options. Finish options are separated by a vertical ruled line. Lead finish/Ball material values may wrap to two lines if the finish value exceeds the maximum column width.

(5) **MSL rating/Peak reflow:** The moisture sensitivity level ratings and peak solder (reflow) temperatures. In the event that a part has multiple moisture sensitivity ratings, only the lowest level per JEDEC standards is shown. Refer to the shipping label for the actual reflow temperature that will be used to mount the part to the printed circuit board.

(6) **Part marking:** There may be an additional marking, which relates to the logo, the lot trace code information, or the environmental category of the part.

Multiple part markings will be inside parentheses. Only one part marking contained in parentheses and separated by a "~" will appear on a part. If a line is indented then it is a continuation of the previous line and the two combined represent the entire part marking for that device.

Important Information and Disclaimer: The information provided on this page represents TI's knowledge and belief as of the date that it is provided. TI bases its knowledge and belief on information provided by third parties, and makes no representation or warranty as to the accuracy of such information. Efforts are underway to better integrate information from third parties. TI has taken and continues to take reasonable steps to provide representative and accurate information but may not have conducted destructive testing or chemical analysis on incoming materials and chemicals. TI and TI suppliers consider certain information to be proprietary, and thus CAS numbers and other limited information may not be available for release.

In no event shall TI's liability arising out of such information exceed the total purchase price of the TI part(s) at issue in this document sold by TI to Customer on an annual basis.

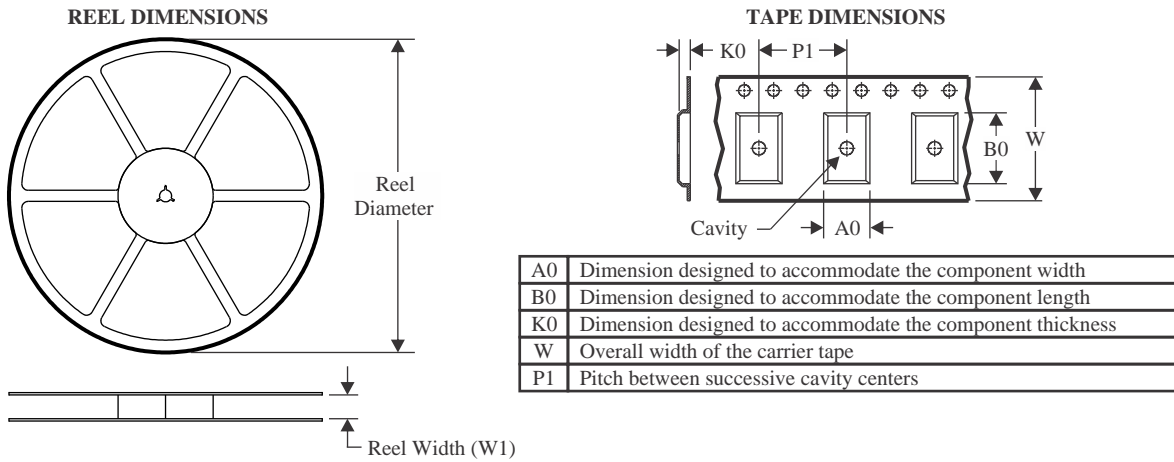
TAPE AND REEL INFORMATION

QUADRANT ASSIGNMENTS FOR PIN 1 ORIENTATION IN TAPE

*All dimensions are nominal

Device	Package Type	Package Drawing	Pins	SPQ	Reel Diameter (mm)	Reel Width W1 (mm)	A0 (mm)	B0 (mm)	K0 (mm)	P1 (mm)	W (mm)	Pin1 Quadrant
LMG2100R044RARR	VQFN-FCRLF	RAR	16	2500	330.0	16.4	4.8	5.8	1.15	8.0	16.0	Q1

TAPE AND REEL BOX DIMENSIONS

*All dimensions are nominal

Device	Package Type	Package Drawing	Pins	SPQ	Length (mm)	Width (mm)	Height (mm)
LMG2100R044RARR	VQFN-FCRLF	RAR	16	2500	367.0	367.0	38.0

RAR0017B

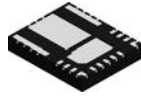

PACKAGE OUTLINE
VQFN-FCRLF - 0.85 mm max height

PLASTIC QUAD FLATPACK - NO LEAD

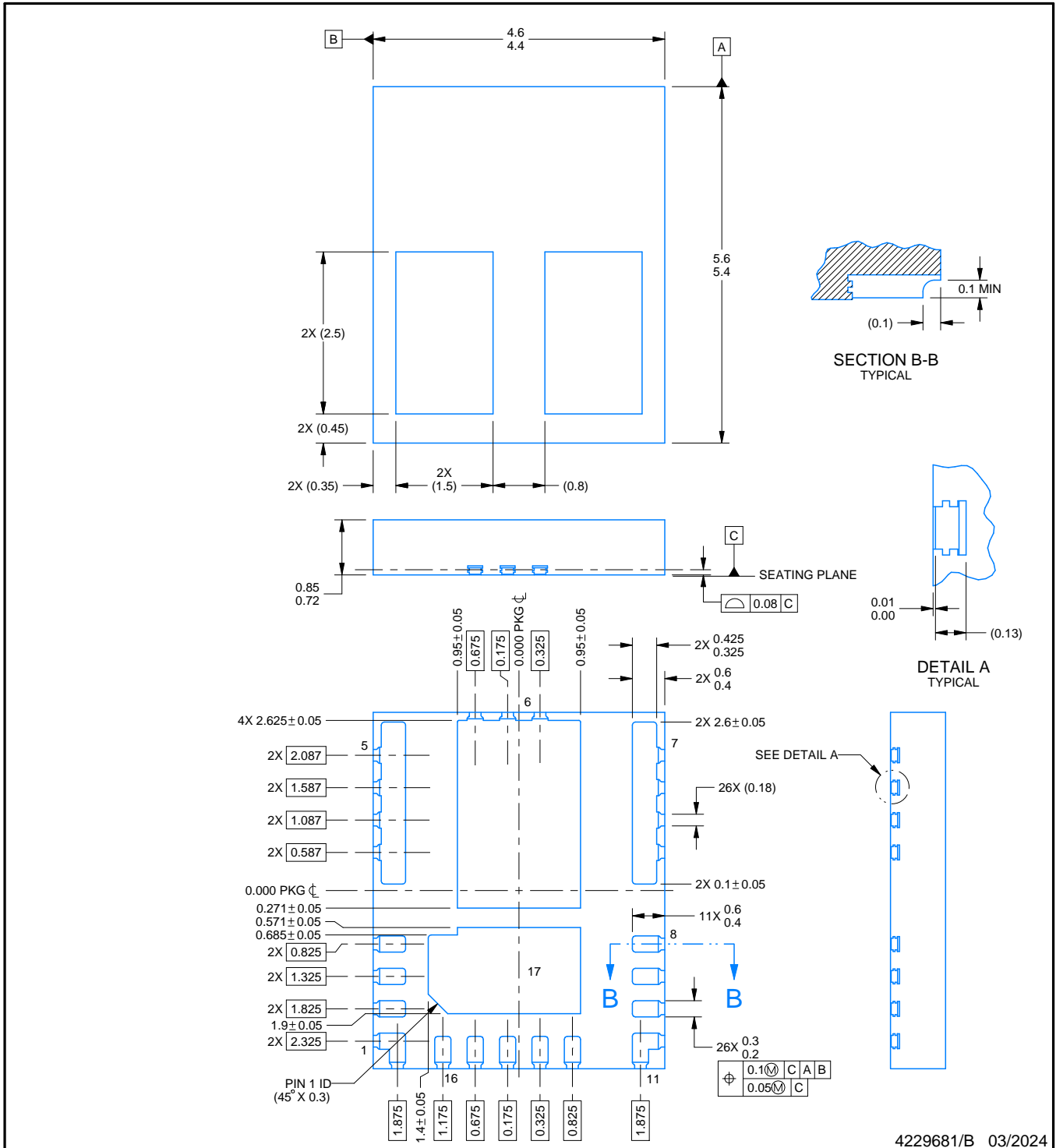

4229681/B 03/2024

NOTES:

1. All linear dimensions are in millimeters. Any dimensions in parenthesis are for reference only. Dimensioning and tolerancing per ASME Y14.5M.
2. This drawing is subject to change without notice.
3. The package thermal pad must be soldered to the printed circuit board for thermal and mechanical performance.

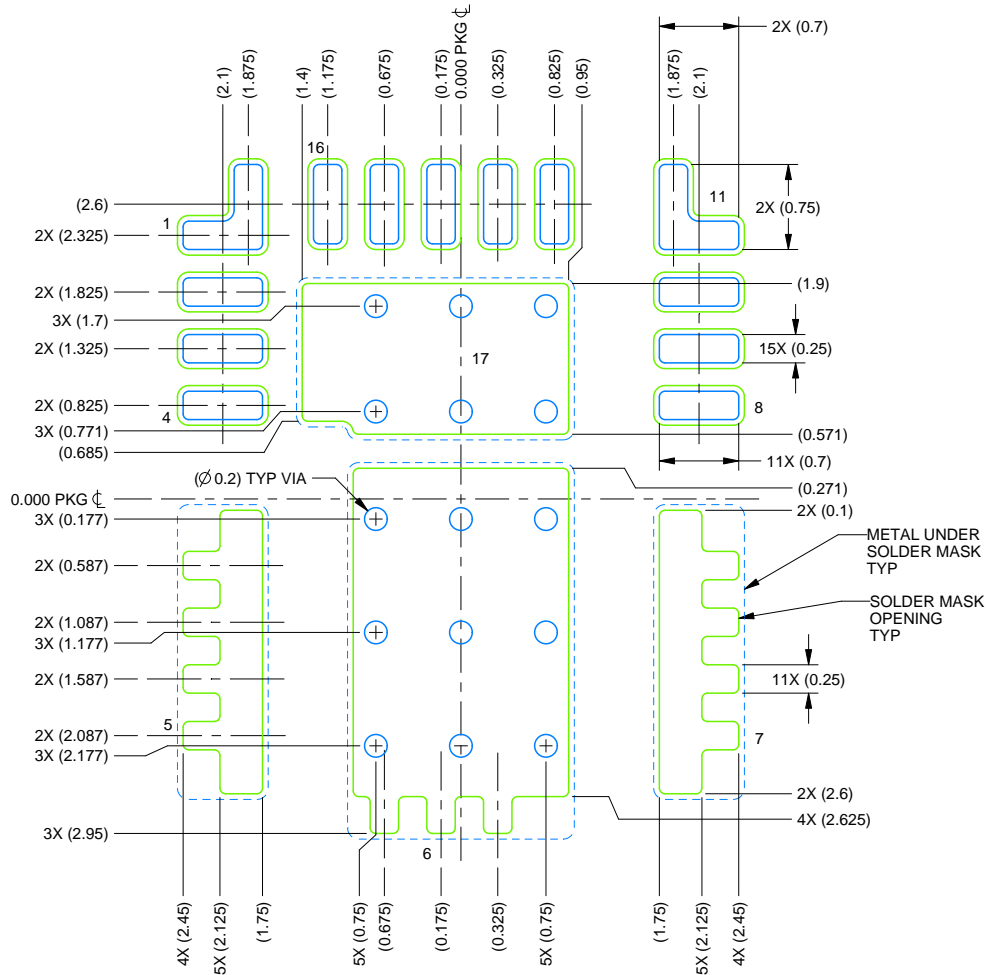

LAND PATTERN EXAMPLE
SCALE: 15X

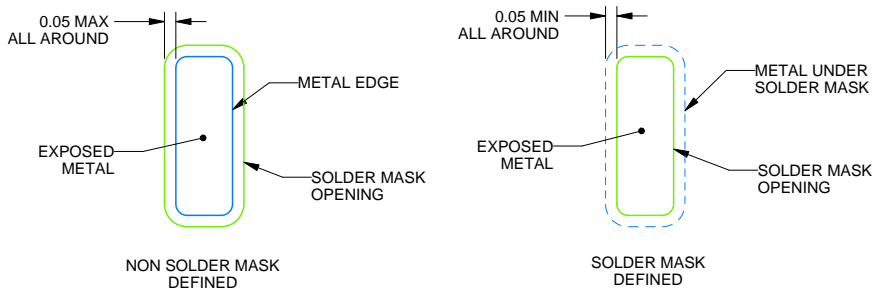

SOLDER MASK DETAILS

4229681/B 03/2024

NOTES: (continued)

4. This package is designed to be soldered to a thermal pad on the board. For more information, see Texas Instruments literature number SLUA271 (www.ti.com/lit/sluea271).
5. Vias are optional depending on application, refer to device data sheet. If any vias are implemented, refer to their locations shown on this view. It is recommended that vias under paste be filled, plugged or tented.

EXAMPLE STENCIL DESIGN

RAR0017B

VQFN-FCRLF - 0.85 mm max height

PLASTIC QUAD FLATPACK - NO LEAD

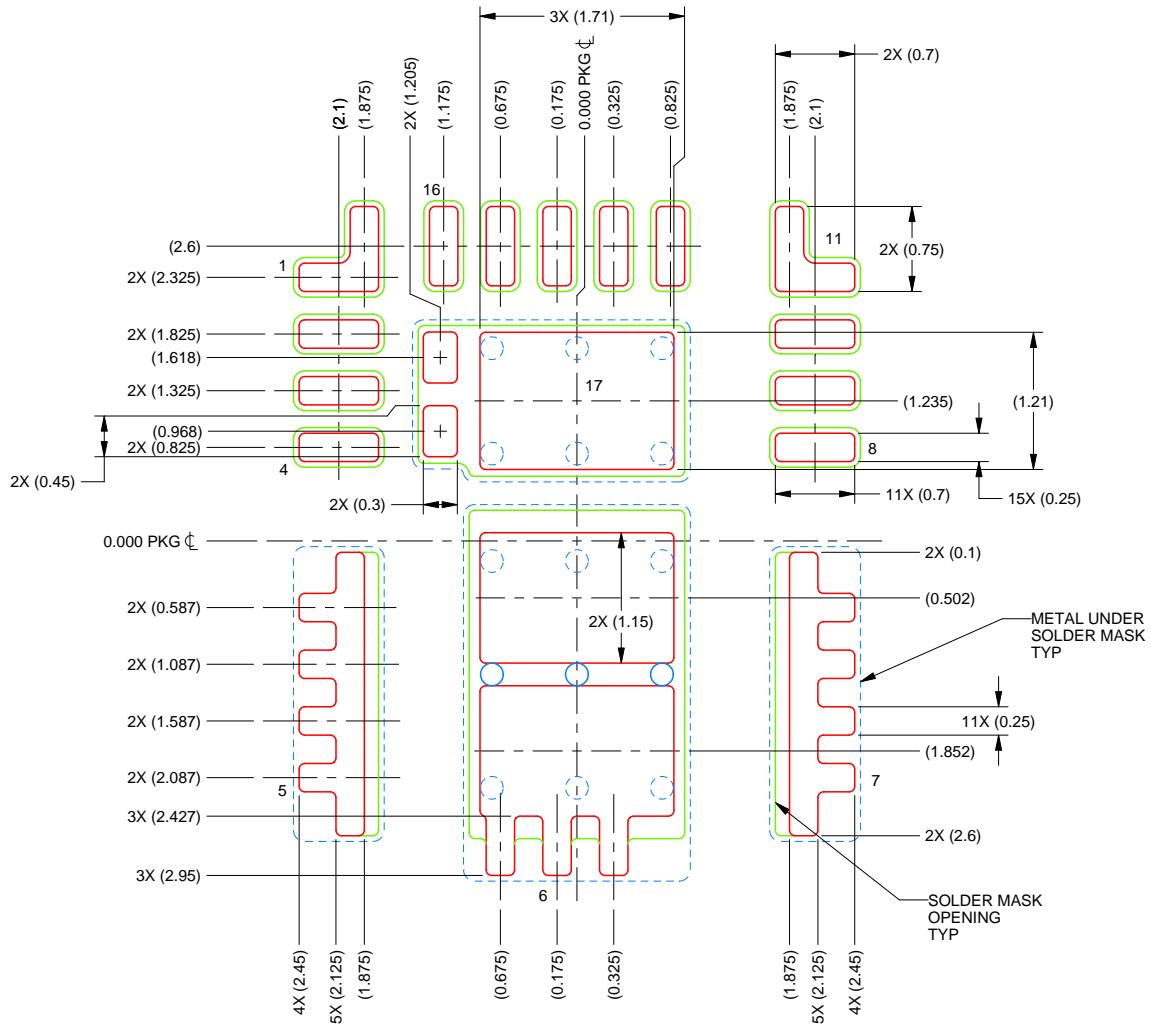

SOLDER PASTE EXAMPLE
 BASED ON 0.125 mm THICK STENCIL
 SCALE: 15X

PRINTED SOLDER COVERAGE BY AREA UNDER PACKAGE
 PAD 5, 6 & 7: 75%
 PAD 17: 76%

4229681/B 03/2024

NOTES: (continued)

6. Laser cutting apertures with trapezoidal walls and rounded corners may offer better paste release. IPC-7525 may have alternate design recommendations.

IMPORTANT NOTICE AND DISCLAIMER

TI PROVIDES TECHNICAL AND RELIABILITY DATA (INCLUDING DATASHEETS), DESIGN RESOURCES (INCLUDING REFERENCE DESIGNS), APPLICATION OR OTHER DESIGN ADVICE, WEB TOOLS, SAFETY INFORMATION, AND OTHER RESOURCES "AS IS" AND WITH ALL FAULTS, AND DISCLAIMS ALL WARRANTIES, EXPRESS AND IMPLIED, INCLUDING WITHOUT LIMITATION ANY IMPLIED WARRANTIES OF MERCHANTABILITY, FITNESS FOR A PARTICULAR PURPOSE OR NON-INFRINGEMENT OF THIRD PARTY INTELLECTUAL PROPERTY RIGHTS.

These resources are intended for skilled developers designing with TI products. You are solely responsible for (1) selecting the appropriate TI products for your application, (2) designing, validating and testing your application, and (3) ensuring your application meets applicable standards, and any other safety, security, regulatory or other requirements.

These resources are subject to change without notice. TI grants you permission to use these resources only for development of an application that uses the TI products described in the resource. Other reproduction and display of these resources is prohibited. No license is granted to any other TI intellectual property right or to any third party intellectual property right. TI disclaims responsibility for, and you fully indemnify TI and its representatives against any claims, damages, costs, losses, and liabilities arising out of your use of these resources.

TI's products are provided subject to [TI's Terms of Sale](#), [TI's General Quality Guidelines](#), or other applicable terms available either on ti.com or provided in conjunction with such TI products. TI's provision of these resources does not expand or otherwise alter TI's applicable warranties or warranty disclaimers for TI products. Unless TI explicitly designates a product as custom or customer-specified, TI products are standard, catalog, general purpose devices.

TI objects to and rejects any additional or different terms you may propose.

Copyright © 2026, Texas Instruments Incorporated

Last updated 10/2025

Looking for pricing, stock, or lifecycle information?

Click below to explore more details on WIN SOURCE:

 [View LM61440AANRJRR on WIN SOURCE](#)

 [Texas Instruments](#) Information

Optimize Your Supply Chain with WIN SOURCE Solutions

-  Global Sourcing Solution
-  Obsolete Management
-  Cost Control Management
-  Shortage Management
-  Alternative Solution
-  Excess Inventory Management