



THE DATASHEET OF NXV55UNR



NXS0506

SD 3.0-compatible memory card integrated auto-direction control and level translator with EMI filter and ESD protection

Rev. 4.1 — 31 July 2024

Product data sheet

1. General description

The NXS0506 is an SD 3.0-compatible bidirectional dual supply level translator with auto-direction control. It is designed to interface between a memory card operating at 1.7 V to 3.6 V signal levels and a host with a nominal supply voltage of 1.1 V to 1.95 V. The device supports SD 3.0: SDR104, SDR50, DDR50, SDR25, SDR12 and SD 2.0 High-Speed (50 MHz) and Default-Speed (25 MHz) modes. The device has a built-in EMI filter and robust ESD protection (IEC 61000-4-2, level 4).

2. Features and benefits

- Supports up to 208 MHz clock rate
- SD 3.0 specification-compatible voltage translation to support: SDR104, SDR50, DDR50, SDR25, SDR12, High-Speed and Default-Speed modes
- 1.1 V to 1.95 V host side interface voltage support
- Auto-direction sensing
- Low power consumption
- Integrated pull-up resistors: no external resistors required
- Integrated EMI filters suppress higher harmonics of digital I/Os
- Level shifting buffers keep ESD stress away from the host (zero-clamping concept)
- 16-bumps WLCSP16 package; pitch 0.35 mm
- 16-terminal XQFN16 package; pitch 0.4 mm
- Latch-up performance exceeds 100 mA per JESD78 Class II.A
- ESD protection:
 - HBM: ANSI/ESDA/JEDEC JS-001 class 2 exceeds 2000 V
 - CDM: ANSI/ESDA/JEDEC JS-002 class C3 exceeds 1000 V
 - IEC61000-4-2, level 4, contact discharge on all memory card-side pins exceeds 8000 V
 - IEC61000-4-2, level 4, air discharge on all memory card-side pins exceeds 15000 V
- Specified from -40 °C to +85 °C

3. Applications

- Smartphone
- Mobile handsets
- Digital cameras
- Tablet PCs
- Laptop computers
- SD, MMC or microSD card readers

4. Ordering information

Table 1. Ordering information

Type number	Package			Version
	Temperature range	Name	Description	
NXS0506UP	-40 °C to +85 °C	WLCSP16	wafer level chip-scale package; 16 bumps; 1.455 × 1.455 × 0.43 mm body	SOT8025-1
NXS0506GU	-40 °C to +85 °C	XQFN16	plastic, extremely thin quad flat package; no leads; 16 terminals; body 1.80 × 2.60 × 0.50 mm	SOT1161-1

5. Marking

Table 2. Marking codes

Type number	Marking code
NXS0506UP	m5
NXS0506GU	m5

6. Block diagram

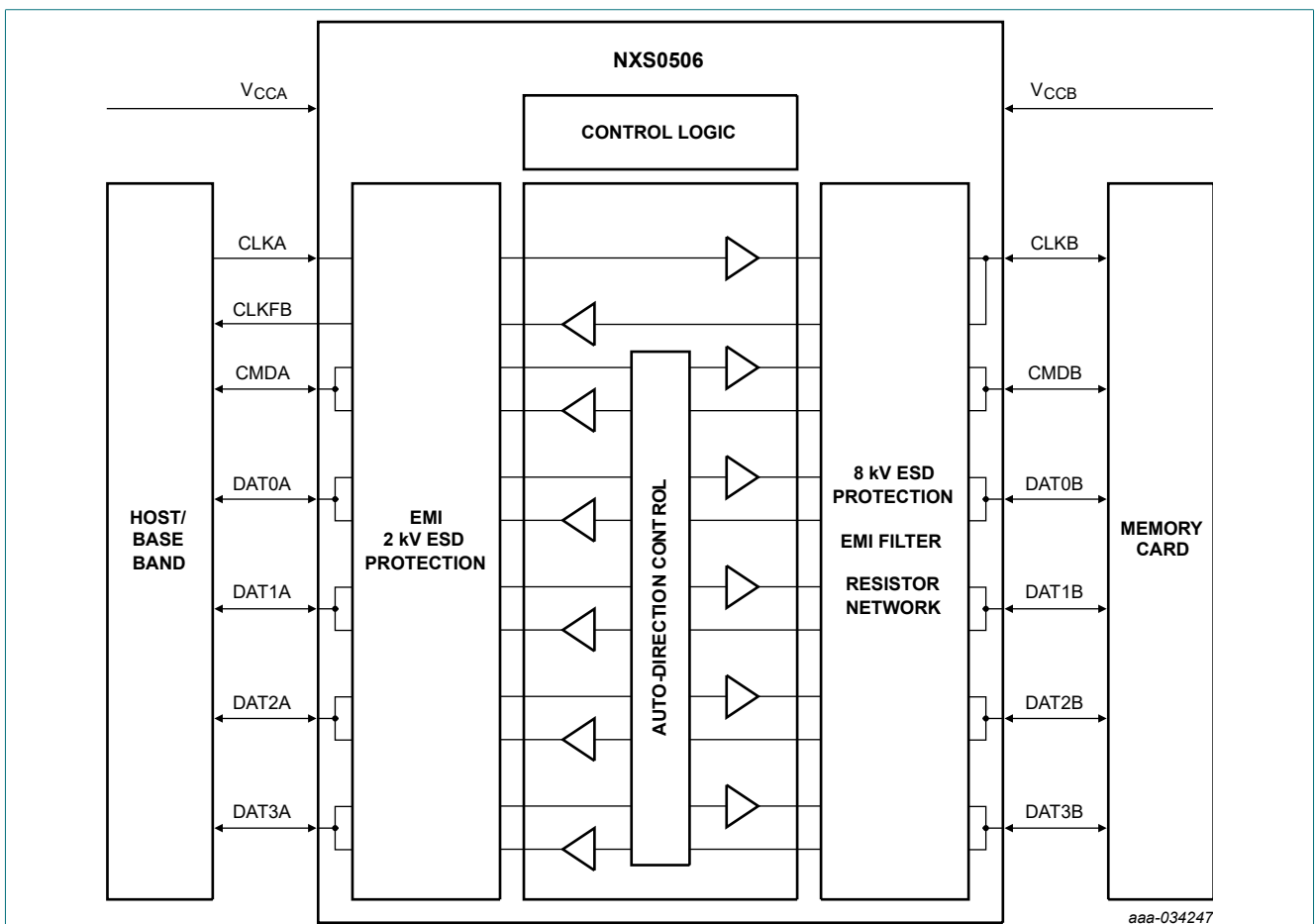
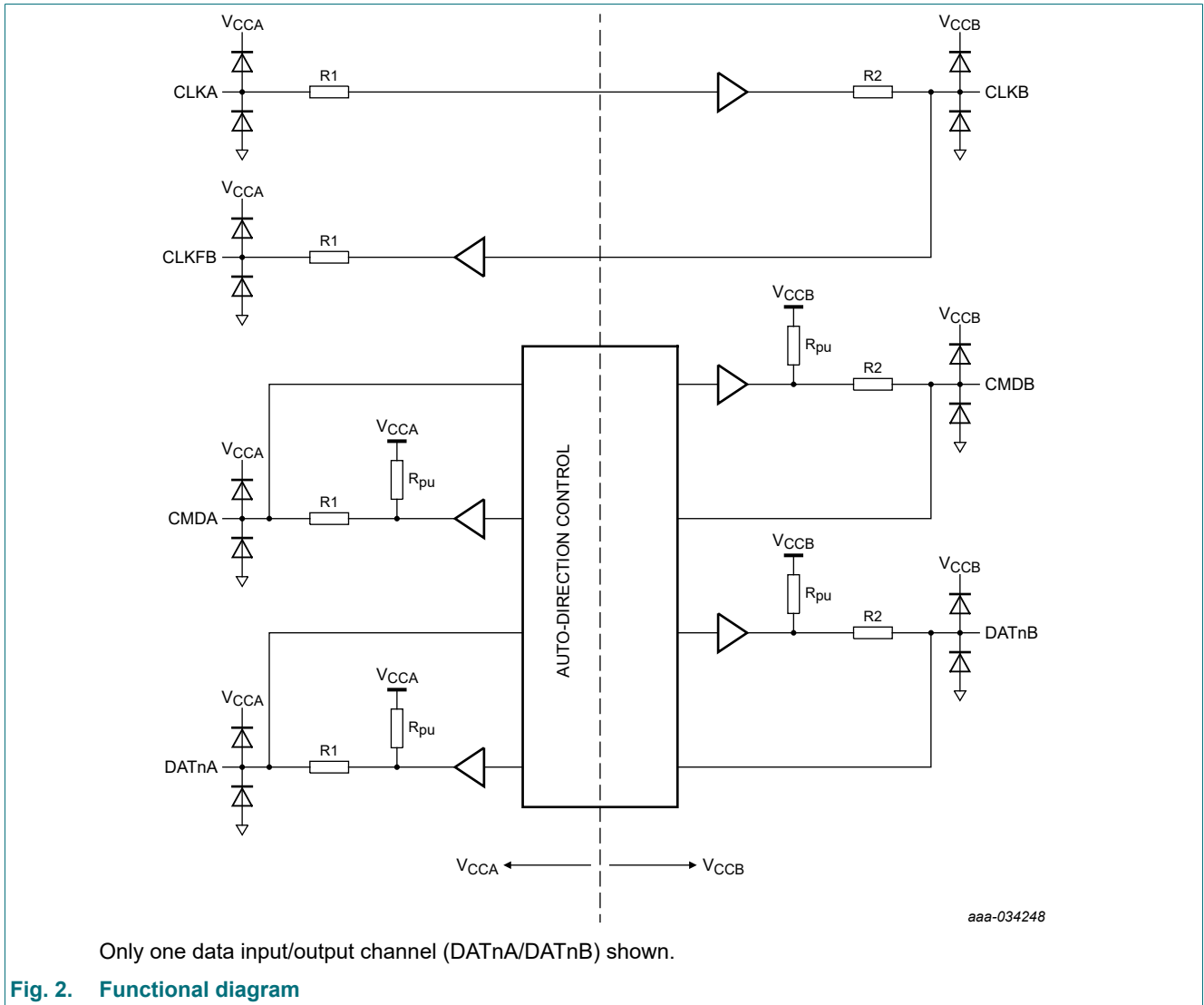

Fig. 1. Block diagram

7. Functional diagram



Only one data input/output channel (DATnA/DATnB) shown.

Fig. 2. Functional diagram

8. Pinning information

8.1. Pinning

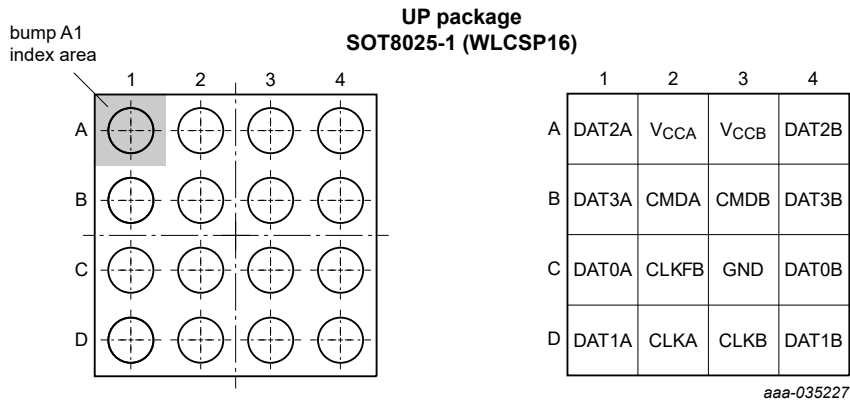

Transparent top view

Bump CLKFB (C2) can be left floating.

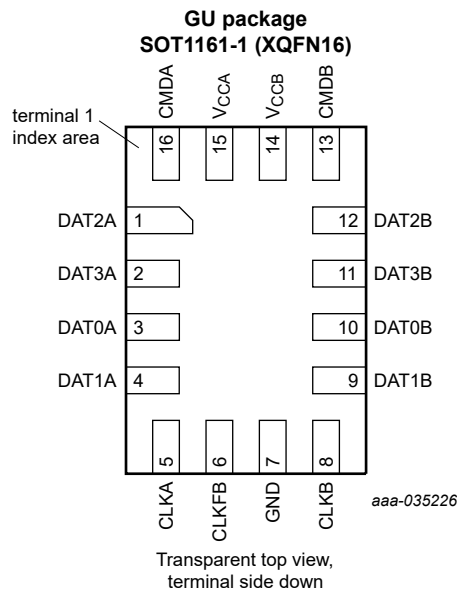

8.2. Pin description

Table 3. Pin description

Symbol[1]	Bump/Pin		Description
	WLCSP16	XQFN16	
DAT2A	A1	1	data 2 input or output on host side
DAT3A	B1	2	data 3 input or output on host side
DAT0A	C1	3	data 0 input or output on host side
DAT1A	D1	4	data 1 input or output on host side
V _{CCA}	A2	15	supply voltage A (host side)
CMDA	B2	16	command input or output on host side
CLKFB	C2	6	clock feedback signal on host side, this pin can be left floating
CLKA	D2	5	clock signal input on host side
V _{CCB}	A3	14	supply voltage B (memory card side)
CMDB	B3	13	command input or output on memory card side
GND	C3	7	supply ground
CLKB	D3	8	clock signal input on memory card side
DAT2B	A4	12	data 2 input or output on memory card side
DAT3B	B4	11	data 3 input or output on memory card side
DAT0B	C4	10	data 0 input or output on memory card side
DAT1B	D4	9	data 1 input or output on memory card side

[1] The pin names relate particularly to SD memory cards, but also apply to microSD and MMC memory cards. See [Section 9.6](#) for options to swap identical channels.

9. Functional description

9.1. Level translator

The bidirectional level translator shifts the data between the I/O supply levels of the host and the memory card. Auto direction sensing circuitry determines if a command and data signals are transferred from the memory card to the host (card read mode) or from the host to the memory card (card write mode). The voltage translator has to support several clock and data transfer rates at the signaling levels specified in the SD 3.0 standard specification.

Table 4. Supported modes

Bus speed mode	Signal level (V)	Clock rate (MHz)	Data rate (MB/s)
Default-Speed	3.3	25	12.5
High-Speed	3.3	50	25
SDR12	1.8	25	12.5
SDR25	1.8	50	25
SDR50	1.8	100	50
SDR104	1.8	208	104
DDR50	1.8	50	50

9.2. Enable and direction control

The device contains an auto-enable feature. If V_{CCB} rises above 1.5 V, the level translator logic is enabled automatically. As soon as V_{CCB} drops below 0.65 V, the memory card side drivers and the level translator logic are disabled. All pins on the host side, excluding CLKA are configured as inputs with a 70 k Ω resistor pulled up to V_{CCA} .

The device features an auto correction control for all data channels except CLK. For these pins the direction of data flow is sensed by the direction control logic and the output drivers are controlled accordingly. There is no need for the host interface to indicate the direction of data flow.

9.3. Feedback clock channel

The clock is transmitted from the host to the memory card side. The voltage translator and the Printed-Circuit Board (PCB) tracks introduce some amount of delay. It reduces timing margin for data read back from memory card, especially at higher data rates. Therefore, a feedback path is provided to compensate the delay. The reasoning behind this approach is the fact that the clock is always delivered by the host, while the data in the timing critical read mode comes from the card.

9.4. EMI filter

All input/output driver stages are equipped with EMI filters to reduce interference towards sensitive mobile communication.

9.5. ESD protection

The device has robust ESD protections on all memory card pins. The architecture prevents any stress for the host: the voltage translator discharges any stress to supply ground.

9.6. Pin and channel naming

The channel/pin naming as shown in [Fig. 2](#) and in [Section 8](#) aims at using NXS0506 for SD-card interfaces. The sequence of the channels is chosen to easily connect to SD-card connectors. As the internal design of channels DAT0 (pins DAT0A and DAT0B), DAT1 (pins DAT1A and DAT1B), DAT2 (pins DAT2A and DAT2B), DAT3 (pins DAT3A and DAT3B) and CMD (pins CMDA and CMDB) is identical, these channels can be exchanged. Swapping channels in the above mentioned group can help ease PCB layout issues. E.g. DAT0 can be swapped with DAT1 or DAT3 with CMD without impact on functionality of NXS0506.

10. Limiting values

Table 5. Limiting values

In accordance with the Absolute Maximum Rating System (IEC 60134).

Symbol	Parameter	Conditions	Min	Max	Unit
V _{CC}	supply voltage	4 ms transient; on pin V _{CCA}	-0.5	4.6	V
		4 ms transient; on pin V _{CCB}	-0.5	4.6	V
I _{IK}	input clamping current	V _I < -0.3 V or V _I > V _{CC} + 0.3 V [1]	-	±20	mA
V _I	input voltage	4 ms transient at I/O pins	-0.5	4.6	V
I _{OK}	output clamping current	V _O < -0.3 V or V _O > V _{CCA} + 0.3 V [1]	-	±20	mA
		V _O < -0.3 V or V _O > V _{CCB} + 0.3 V [1]	-	±50	mA
P _{tot}	total power dissipation	T _{amb} = -40 °C to +85 °C	-	250	mW
T _{stg}	storage temperature		-55	+150	°C
I _{IU(I/O)}	input/output latch-up current	JESD78F: -0.5V _{CC} < V _I < 1.5V _{CC} ; T _J < 125 °C	-100	100	mA

[1] The input and output voltage ratings may be exceeded if the input and output current ratings are observed.

11. Recommended operating conditions

Table 6. Operating conditions

Symbol	Parameter	Conditions	Min	Typ	Max	Unit
V _{CC}	supply voltage	on pin V _{CCA} [1]	1.1	-	1.95	V
		on pin V _{CCB} [1]	1.7	-	3.6	V
V _I	input voltage	host side	-0.3	-	V _{CCA} + 0.3	V
		memory card side [2]	-0.3	-	V _{CCB} + 0.3	V
T _{amb}	ambient temperature		-40	+25	+85	°C

[1] V_{CCB} ≥ V_{CCA}

[2] The voltage must not exceed 3.6 V.

Table 7. Integrated resistors

Symbol	Parameter	Conditions	T _{amb} = -40 °C to +85 °C			Unit
			Min	Typ[1]	Max	
R _{pu}	pull-up resistance		42	70	100	kΩ
R _s	series resistance	host side; R1 [2]	-	22.5	-	Ω
		card side; R2 [2]	-	15	-	Ω

[1] Typical values are measured at T_{amb} = 25 °C.

[2] Guaranteed by design and characterization.

12. Static characteristics

Table 8. Static characteristics

At recommended operating conditions; voltages are referenced to GND (ground = 0 V) unless otherwise specified.

Symbol	Parameter	Conditions	T _{amb} = -40 °C to +85 °C			Unit
			Min	Typ[1]	Max	
Automatic enable feature: V_{CCB}						
V _{en}	device enable voltage level	V _{CCA} ≥ 1.0 V; V _{CCB} rising edge	0.9	1.2	1.5	V
V _{dis}	device disable voltage level	V _{CCA} ≥ 1.0 V; V _{CCB} falling edge	0.65	1.0	1.3	V
Host-side input signals: CMDA, DAT0A to DAT3A and CLKA						
V _{IH}	HIGH-level input voltage	1.1 V ≤ V _{CCA} ≤ 1.95 V	0.65V _{CCA}	-	V _{CCA} + 0.3	V
V _{IL}	LOW-level input voltage	1.1 V ≤ V _{CCA} ≤ 1.95 V	-0.3	-	0.35V _{CCA}	V
I _I	input leakage current	CLKA; V _{CCA} = 1.95 V; V _I = 0 V to 1.95 V	-	-	1	μA
Host-side output signals: CMDA and DAT0A to DAT3A						
V _{OH}	HIGH-level output voltage	I _O = -2 μA; V _I = V _{IH} (card side); 1.1 V ≤ V _{CCA} ≤ 1.95 V	0.8V _{CCA}	-	V _{CCA} + 0.3	V
V _{OL}	LOW-level output voltage	I _O = 2 mA; V _I = V _{IL} (card side); 1.1 V ≤ V _{CCA} ≤ 1.95 V	-0.3	-	0.15V _{CCA}	V
Host-side output signals: CLKFB						
V _{OH}	HIGH-level output voltage	I _O = -2 mA; V _I = V _{IH} (host side); 1.1 V ≤ V _{CCA} ≤ 1.95 V	0.8V _{CCA}	-	V _{CCA} + 0.3	V
V _{OL}	LOW-level output voltage	I _O = 2 mA; V _I = V _{IL} (host side); 1.1 V ≤ V _{CCA} ≤ 1.95 V	-0.3	-	0.15V _{CCA}	V
Card-side input signals: CMDb and DAT0B to DAT3B						
V _{IH}	HIGH-level input voltage	1.7 V ≤ V _{CCB} ≤ 3.6 V	0.625V _{CCB}	-	V _{CCB} + 0.3	V
V _{IL}	LOW-level input voltage	1.7 V ≤ V _{CCB} ≤ 1.95 V	-0.3	-	0.35V _{CCB}	V
		2.7 V ≤ V _{CCB} ≤ 3.6 V	-0.3	-	0.30V _{CCB}	V
Card-side output signal: CMDb, DAT0B to DAT3B and CLKb						
V _{OH}	HIGH-level output voltage	CLKb; V _{CCB} = 1.7 V; I _O = -2 mA; V _I = V _{IH} (host side)	0.85V _{CCB}	-	2.0	V
		CLKb; V _{CCB} = 2.7 V; I _O = -4 mA; V _I = V _{IH} (host side)	0.85V _{CCB}	-	V _{CCB} + 0.3	V
		CMDB, DATnB; V _{CCB} = 1.7 V; I _O = -2 μA; V _I = V _{IH} (host side)	0.85V _{CCB}	-	2.0	V
V _{OL}	Low-level output voltage	I _O = 2 mA; V _I = V _{IL} (host side); V _{CCB} = 1.7 V	-0.3	-	0.125V _{CCB}	V
		I _O = 4 mA; V _I = V _{IL} (host side); V _{CCB} = 2.7 V	-0.3	-	0.125V _{CCB}	V

SD 3.0-compatible memory card integrated auto-direction control and level translator with EMI filter and ESD protection

Symbol	Parameter	Conditions	T _{amb} = -40 °C to +85 °C			Unit
			Min	Typ[1]	Max	
Current consumption						
I _{CC}	supply current	host side; all inputs = HIGH; V _I = V _{CCA} ; V _{CCA} = 1.95 V; V _{CCB} = 3.6 V	-	-	4	μA
		card side; all inputs = HIGH; V _I = V _{CCA} ; V _{CCA} = 1.7 V; V _{CCB} = 1.7 V	-	-	7	μA
		card side; all inputs = HIGH; V _I = V _{CCA} ; V _{CCA} = 1.95 V; V _{CCB} = 3.6 V	-	-	20	μA

[1] Typical values are measured at T_{amb} = 25 °C.

13. Dynamic characteristics

13.1. Level translator

Table 9. Level translator dynamic characteristics

At recommended operating conditions; for waveform and test circuit see Fig. 3 and Fig. 4.

Symbol	Parameter	Conditions	T _{amb} = -40 °C to 85 °C			Unit
			Min	Typ[1]	Max	
Host-side output transition times						
t _t	transition time	V _{CCA} = 1.2 V to 1.8 V; output transition time between V _X = 0.35V _{CCA} and V _Y = 0.65V _{CCA} [2]	-	0.3	1.0	ns
Host-side input rise and fall times						
t _r , t _f	rise and fall time	V _{CCA} = 1.2 V to 1.8 V; input rise and fall time between V _X = 0.35V _{CCA} and V _Y = 0.65V _{CCA}	-	0.4	1.0	ns
Card-side output transition times						
t _t	transition time	V _{CCB} = 1.8 V; output transition time between V _X = 0.45 V and V _Y = 1.4 V [2]	0.4	0.88	1.32	ns
Card-side input rise and fall times						
t _r	rise time	V _{CCB} = 1.8 V; input rise time between 0.58 V and 1.27 V	0.2	0.5	0.96	ns
t _f	fall time	V _{CCB} = 1.8 V; input fall time between 0.58 V and 1.27 V	0.2	0.45	0.96	ns
Host-side to card-side propagation delay; DATnA to DATnB, CMDA to CMDB and CLKA to CLKB						
t _{pd}	propagation delay	V _{CCA} = 1.2 V; V _{CCB} = 1.8 V [3]	-	3.1	5.4	ns
		V _{CCA} = 1.2 V; V _{CCB} = 3.3 V [3]	-	2.2	4.0	ns
		V _{CCA} = 1.8 V; V _{CCB} = 1.8 V [3]	-	2.7	4.8	ns
		V _{CCA} = 1.8 V; V _{CCB} = 3.3 V [3]	-	1.7	3.1	ns
t _{sk(o)}	output skew time	V _{CCA} = 1.2 V; V _{CCB} = 1.8 V	-	-	200	ps
		V _{CCA} = 1.2 V; V _{CCB} = 3.3 V	-	-	200	ps
		V _{CCA} = 1.8 V; V _{CCB} = 1.8 V	-	-	200	ps
		V _{CCA} = 1.8 V; V _{CCB} = 3.3 V	-	-	200	ps

SD 3.0-compatible memory card integrated auto-direction control and level translator with EMI filter and ESD protection

Symbol	Parameter	Conditions	T _{amb} = -40 °C to 85 °C			Unit
			Min	Typ[1]	Max	
Card-side to host-side propagation delay; DATnB to DATnA and CMDb to CMDA						
t _{pd}	propagation delay	V _{CCA} = 1.2 V; V _{CCB} = 1.8 V [3]	-	2.7	4.6	ns
		V _{CCA} = 1.2 V; V _{CCB} = 3.3 V [3]	-	1.7	3.0	ns
		V _{CCA} = 1.8 V; V _{CCB} = 1.8 V [3]	-	2.7	4.6	ns
		V _{CCA} = 1.8 V; V _{CCB} = 3.3 V [3]	-	1.6	2.7	ns
t _{sk(o)}	output skew time	V _{CCA} = 1.2 V; V _{CCB} = 1.8 V	-	-	200	ps
		V _{CCA} = 1.2 V; V _{CCB} = 3.3 V	-	-	200	ps
		V _{CCA} = 1.8 V; V _{CCB} = 1.8 V	-	-	200	ps
		V _{CCA} = 1.8 V; V _{CCB} = 3.3 V	-	-	200	ps
Host-side to host-side propagation delay; CLKA to CLKFB						
t _{pd}	propagation delay	V _{CCA} = 1.2 V; V _{CCB} = 1.8 V [3]	-	5.8	10	ns
		V _{CCA} = 1.2 V; V _{CCB} = 3.3 V [3]	-	3.9	7.0	ns
		V _{CCA} = 1.8 V; V _{CCB} = 1.8 V [3]	-	5.4	9.4	ns
		V _{CCA} = 1.8 V; V _{CCB} = 3.3 V [3]	-	3.3	5.8	ns
Bus signal equivalent capacitance						
C _{I/O}	input/output capacitance	V _I = 0 V; f _i = 1 MHz; V _{CCA} = 1.8 V; host side [4]	-	5	-	pF
		V _I = 0 V; f _i = 1 MHz; V _{CCB} = 1.8 V; card side [4]	-	12	-	pF

- [1] Typical values are measured at T_{amb} = 25 °C.
- [2] t_t is the same as t_{THL} and t_{TLH}.
- [3] t_{pd} is the same as t_{PLH} and t_{PHL}.
- [4] EMI filter line capacitance from I/O driver to pin; C_{I/O} is guaranteed by design.

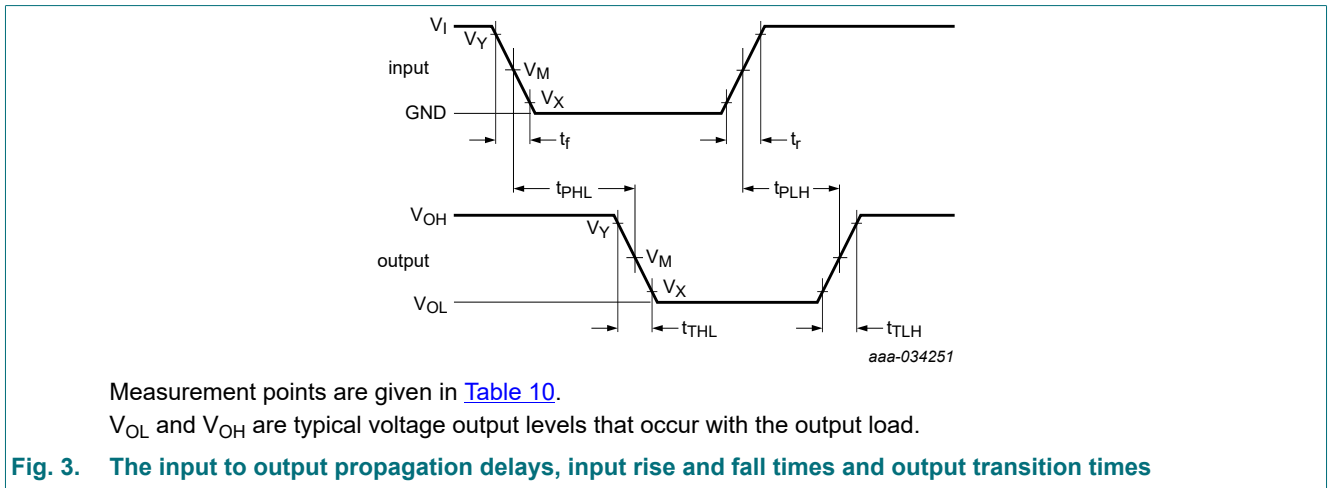
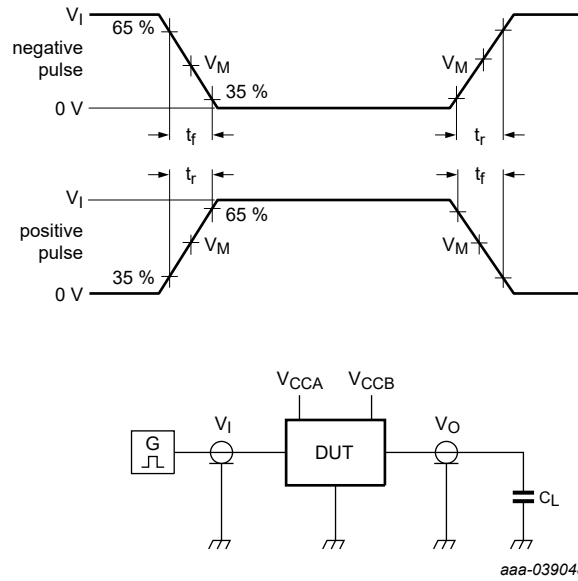

Table 10. Measurement points

Supply voltage		Input		Output
V _{CCA}	V _{CCB}	V _I [1]	V _M [1]	V _M [2]
1.1 V to 1.95 V	1.7 V to 3.6 V	V _{CCI}	0.5V _{CCI}	0.5V _{CCO}

- [1] V_{CCI} is the supply voltage associated with the input.
- [2] V_{CCO} is the supply voltage associated with the output.

SD 3.0-compatible memory card integrated auto-direction control and level translator with EMI filter and ESD protection



Test data is given in [Table 11](#).

All input pulses are supplied by generators having the following characteristics:

PRR ≤ 10 MHz.

Z_O = 50 Ω;

input edges (t_r, t_f) are defined in [Section 13](#);

Definitions test circuit:

C_L = Load capacitance including jig and probe capacitance.

Fig. 4. Test circuit for measuring switching time

Table 11. Test data

Supply voltage		Input	Load	
V _{CCA}	V _{CCB}	V _I [1]	C _L (host side)	C _L (card side)
1.1 V to 1.95 V	1.7 V to 3.6 V	V _{CCI}	10 pF	15 pF

[1] V_{CCI} is the supply voltage associated with the input.

14. Application information

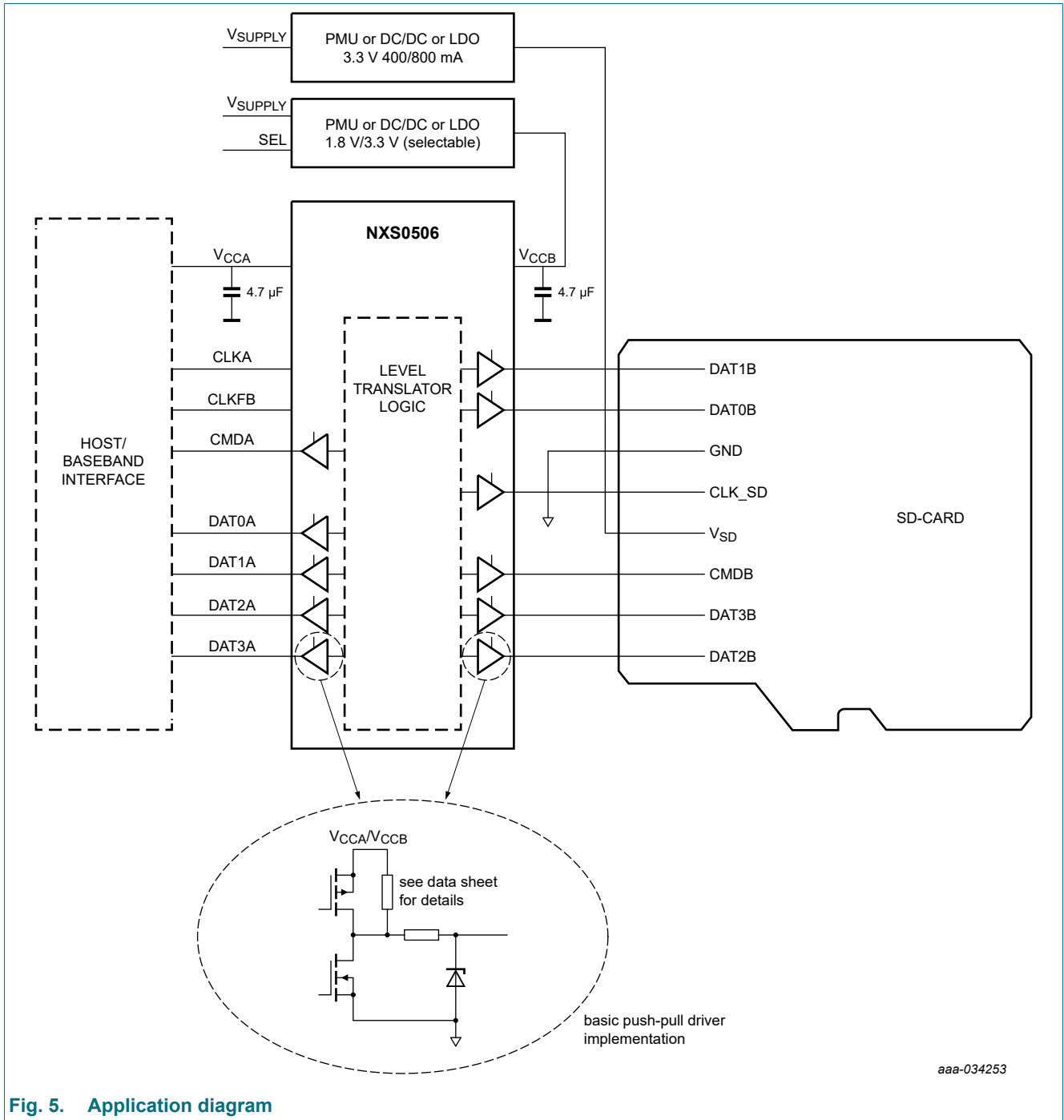

Fig. 5. Application diagram

14.1. PCB design guidelines

The translator can operate with frequencies up to 208 MHz so the PCB connections between host and translator and translator and card can start to act as transmission lines, affecting the signal integrity.

For PCB connections below 8 cm ($t_r = 0.4$ ns) no degradation of the signal integrity is to be expected. For longer connections it's important to take pre-cautions and check the signal integrity during the development phase of the PCB. If the CLKFB is used to synchronize the data that is read from the card, it is important to place the translator as close as possible to the card connector.

15. Design and assembly recommendations

This section is only applicable for type number NXS0506UP (SOT8025-1/WLCSP16).

15.1. PCB design guidelines

For optimum performance, use a Non-Solder Mask PCB Design (NSMD), also known as a copper-defined design, incorporating laser-drilled micro-vias connecting the ground pads to a buried ground-plane layer. This results in the lowest possible ground inductance and provides the best high frequency and ESD performance. For this case, refer to [Table 12](#) for the recommended PCB design parameters.

Table 12. Recommended PCB design parameters

Parameter	Value or specification
PCB Cu pad shape	circular
PCB Cu pad diameter	200 μm
PCB solder resist diameter	270 μm
WLCSP pad diameter (UBM)	200 μm

15.2. PCB assembly guidelines for Pb-free soldering

Table 13. Assembly recommendations

Parameter	Value or specification
PCB stencil shape	circular
PCB stencil aperture diameter	200 μm
PCB stencil thickness	80 μm
Solder paste material	SnAg ₄ Cu (Cu 0.5%) (SAC405)
Solder reflow profile	see Fig. 6

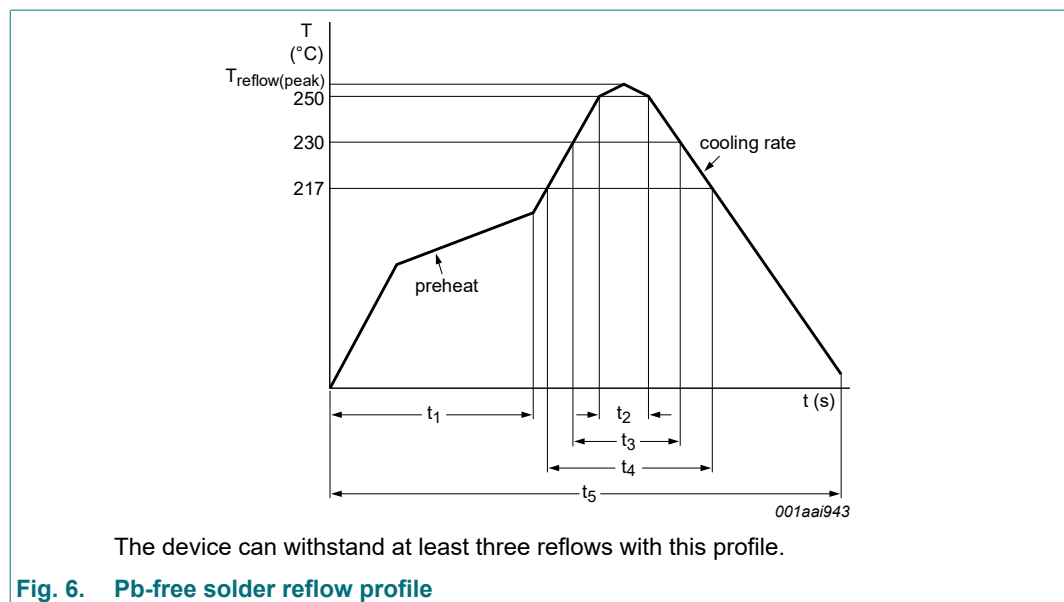

SD 3.0-compatible memory card integrated auto-direction control and level translator with EMI filter and ESD protection

Table 14. Reflow soldering process characteristics

 $T_{amb} = 25\text{ °C}$; unless otherwise specified.

Symbol	Parameter	Conditions	Min	Typ	Max	Unit
$t_{\text{reflow(peak)}}$	peak reflow temperature		230	-	260	°C
t_1	time 1	soak time	60	-	180	s
t_2	time 2	time during $T \geq 250\text{ °C}$	-	-	30	s
t_3	time 3	time during $T \geq 230\text{ °C}$	10	-	50	s
t_4	time 4	time during $T \geq 217\text{ °C}$	30	-	150	s
t_5	time 5		-	-	540	s
dT/dt	rate of temperature change	cooling rate	-	-	-6	°C/s
		preheat	2.5	-	4.0	°C/s

16. Package outline

WLCSP16: wafer level chip-scale package; 16 bumps; 1.455 mm x 1.455 mm x 0.43 mm body

SOT8025-1

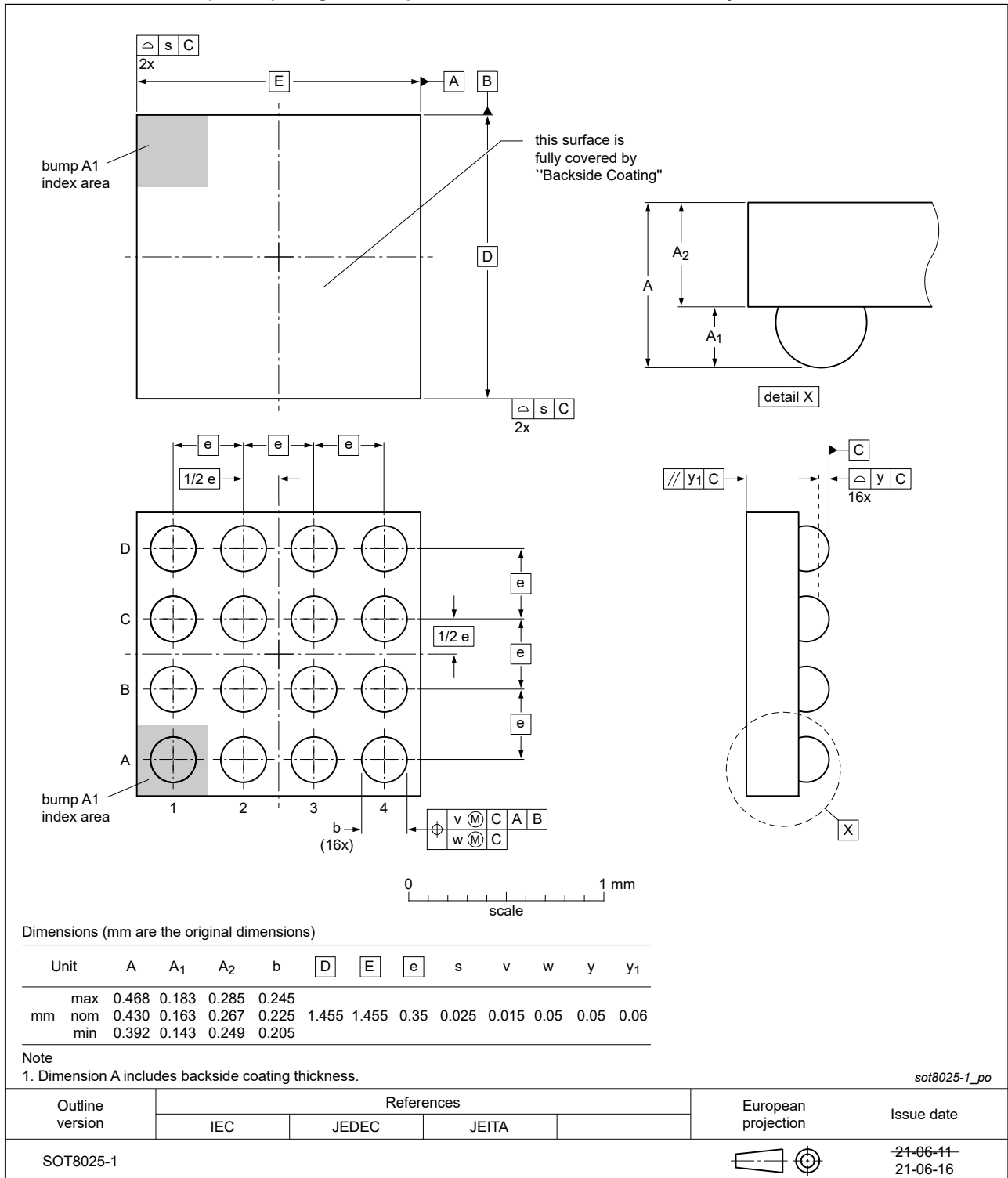

Fig. 7. Package outline SOT8025-1 (WLCSP16)

SD 3.0-compatible memory card integrated auto-direction control and level translator with EMI filter and ESD protection

XQFN16: plastic, extremely thin quad flat package; no leads; 16 terminals; body 1.80 x 2.60 x 0.50 mm

SOT1161-1

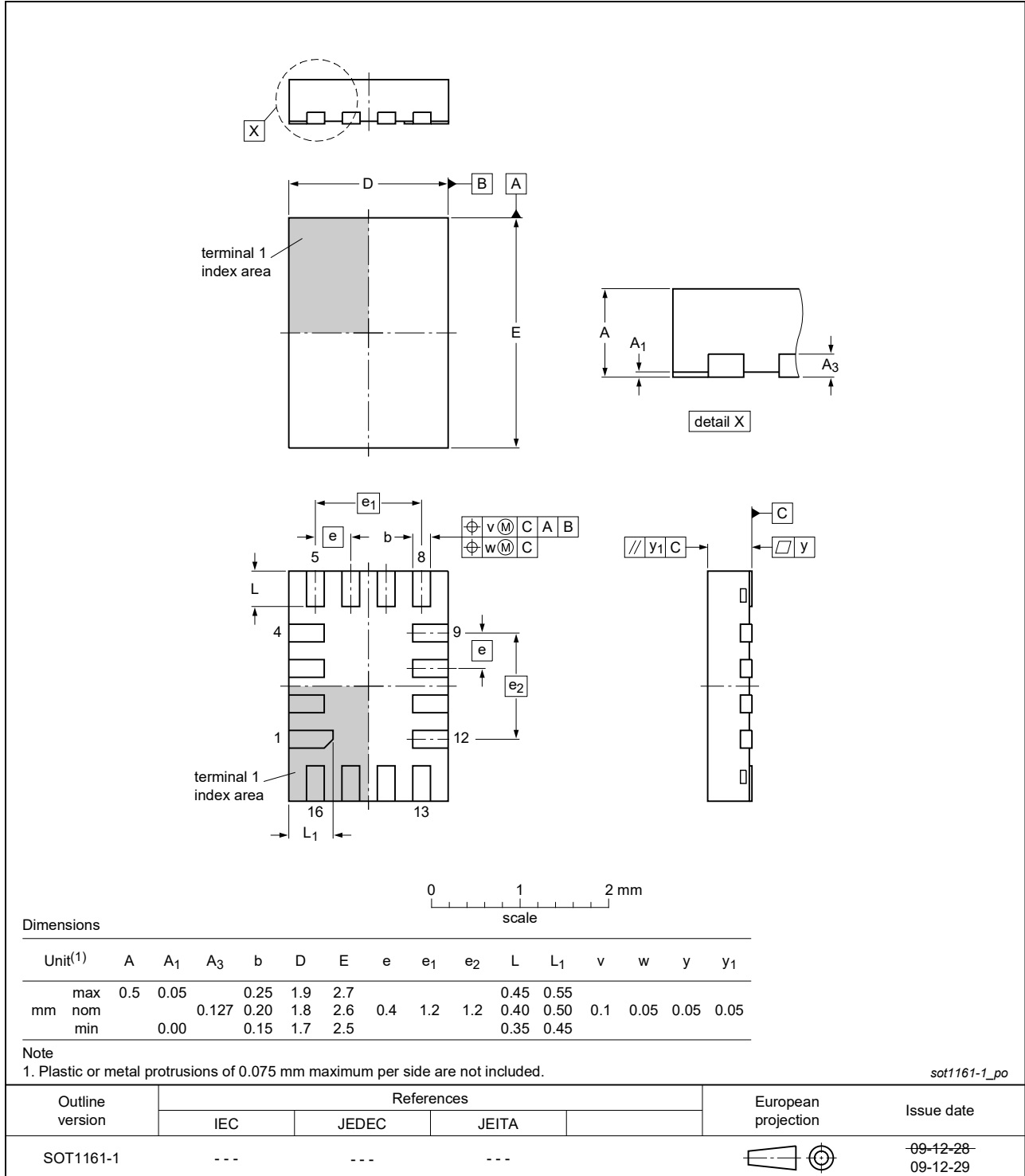

Fig. 8. Package outline SOT1161-1 (XQFN16)

17. Abbreviations

Table 15. Abbreviations

Acronym	Description
ANSI	American National Standards Institute
CDM	Charged Device Model
DUT	Device Under Test
EMI	Electro Magnetic Interface
ESD	ElectroStatic Discharge
ESDA	ElectroStatic Discharge Association
FR4	Flame Retard 4
HBM	Human Body Model
JEDEC	Joint Electron Device Engineering Council
LDO	Low-Dropout
MMC	MultiMedia Card
NSMD	Non-Solder Mask PCB Design
OSP	Organic Solderability Preservation
PCB	Printed-Circuit Board
PMU	Project Management Unit
PRR	Pulse Rate Repetition
RoHS	Restriction of Hazardous Substances
SD	Secure Digital
UBM	Under Bump Metallization
WLCSP	Wafer-Level Chip-Scale Package

18. Revision history

Table 16. Revision history

Data sheet ID	Release date	Data sheet status	Change notice	Supersedes
NXS0506 v.4.1	20240731	Product data sheet	-	NXS0506 v.4
NXS0506 v.4	20240202	Product data sheet	-	NXS0506 v.3
Modifications:	<ul style="list-style-type: none"> • Fig. 2 updated. • Table 5: input and output clamping current added. 			
NXS0506 v.3	20231030	Product data sheet	-	NXS0506 v.2
Modifications:	<ul style="list-style-type: none"> • Type number NXS0506GU (SOT1161-1/XQFN16) added. • Section 2 updated. • Section 12: input leakage current conditions have changed. (errata) • Table 9 updated, with additional output skew time ($t_{sk(o)}$) parameters. • Fig. 5: application diagram updated. • Section 15 updated. 			
NXS0506 v.2	20220308	Product data sheet	-	NXS0506 v.1
Modifications:	<ul style="list-style-type: none"> • Fig. 1 and Fig. 2 have changed (errata). 			
NXS0506 v.1	20220131	Product data sheet	-	-

SD 3.0-compatible memory card integrated auto-direction control and level translator with EMI filter and ESD protection

19. Legal information

Data sheet status

Document status [1][2]	Product status [3]	Definition
Objective [short] data sheet	Development	This document contains data from the objective specification for product development.
Preliminary [short] data sheet	Qualification	This document contains data from the preliminary specification.
Product [short] data sheet	Production	This document contains the product specification.

- [1] Please consult the most recently issued document before initiating or completing a design.
- [2] The term 'short data sheet' is explained in section "Definitions".
- [3] The product status of device(s) described in this document may have changed since this document was published and may differ in case of multiple devices. The latest product status information is available on the internet at <https://www.nexperia.com>.

Definitions

Draft — The document is a draft version only. The content is still under internal review and subject to formal approval, which may result in modifications or additions. Nexperia does not give any representations or warranties as to the accuracy or completeness of information included herein and shall have no liability for the consequences of use of such information.

Short data sheet — A short data sheet is an extract from a full data sheet with the same product type number(s) and title. A short data sheet is intended for quick reference only and should not be relied upon to contain detailed and full information. For detailed and full information see the relevant full data sheet, which is available on request via the local Nexperia sales office. In case of any inconsistency or conflict with the short data sheet, the full data sheet shall prevail.

Product specification — The information and data provided in a Product data sheet shall define the specification of the product as agreed between Nexperia and its customer, unless Nexperia and customer have explicitly agreed otherwise in writing. In no event however, shall an agreement be valid in which the Nexperia product is deemed to offer functions and qualities beyond those described in the Product data sheet.

Disclaimers

Limited warranty and liability — Information in this document is believed to be accurate and reliable. However, Nexperia does not give any representations or warranties, expressed or implied, as to the accuracy or completeness of such information and shall have no liability for the consequences of use of such information. Nexperia takes no responsibility for the content in this document if provided by an information source outside of Nexperia.

In no event shall Nexperia be liable for any indirect, incidental, punitive, special or consequential damages (including - without limitation - lost profits, lost savings, business interruption, costs related to the removal or replacement of any products or rework charges) whether or not such damages are based on tort (including negligence), warranty, breach of contract or any other legal theory.

Notwithstanding any damages that customer might incur for any reason whatsoever, Nexperia's aggregate and cumulative liability towards customer for the products described herein shall be limited in accordance with the Terms and conditions of commercial sale of Nexperia.

Right to make changes — Nexperia reserves the right to make changes to information published in this document, including without limitation specifications and product descriptions, at any time and without notice. This document supersedes and replaces all information supplied prior to the publication hereof.

Suitability for use — Nexperia products are not designed, authorized or warranted to be suitable for use in life support, life-critical or safety-critical systems or equipment, nor in applications where failure or malfunction of an Nexperia product can reasonably be expected to result in personal

injury, death or severe property or environmental damage. Nexperia and its suppliers accept no liability for inclusion and/or use of Nexperia products in such equipment or applications and therefore such inclusion and/or use is at the customer's own risk.

Quick reference data — The Quick reference data is an extract of the product data given in the Limiting values and Characteristics sections of this document, and as such is not complete, exhaustive or legally binding.

Applications — Applications that are described herein for any of these products are for illustrative purposes only. Nexperia makes no representation or warranty that such applications will be suitable for the specified use without further testing or modification.

Customers are responsible for the design and operation of their applications and products using Nexperia products, and Nexperia accepts no liability for any assistance with applications or customer product design. It is customer's sole responsibility to determine whether the Nexperia product is suitable and fit for the customer's applications and products planned, as well as for the planned application and use of customer's third party customer(s). Customers should provide appropriate design and operating safeguards to minimize the risks associated with their applications and products.

Nexperia does not accept any liability related to any default, damage, costs or problem which is based on any weakness or default in the customer's applications or products, or the application or use by customer's third party customer(s). Customer is responsible for doing all necessary testing for the customer's applications and products using Nexperia products in order to avoid a default of the applications and the products or of the application or use by customer's third party customer(s). Nexperia does not accept any liability in this respect.

Limiting values — Stress above one or more limiting values (as defined in the Absolute Maximum Ratings System of IEC 60134) will cause permanent damage to the device. Limiting values are stress ratings only and (proper) operation of the device at these or any other conditions above those given in the Recommended operating conditions section (if present) or the Characteristics sections of this document is not warranted. Constant or repeated exposure to limiting values will permanently and irreversibly affect the quality and reliability of the device.

Terms and conditions of commercial sale — Nexperia products are sold subject to the general terms and conditions of commercial sale, as published at <http://www.nexperia.com/profile/terms>, unless otherwise agreed in a valid written individual agreement. In case an individual agreement is concluded only the terms and conditions of the respective agreement shall apply. Nexperia hereby expressly objects to applying the customer's general terms and conditions with regard to the purchase of Nexperia products by customer.

No offer to sell or license — Nothing in this document may be interpreted or construed as an offer to sell products that is open for acceptance or the grant, conveyance or implication of any license under any copyrights, patents or other industrial or intellectual property rights.

Export control — This document as well as the item(s) described herein may be subject to export control regulations. Export might require a prior authorization from competent authorities.

Non-automotive qualified products — Unless this data sheet expressly states that this specific Nexperia product is automotive qualified, the product is not suitable for automotive use. It is neither qualified nor tested in accordance with automotive testing or application requirements. Nexperia accepts no liability for inclusion and/or use of non-automotive qualified products in automotive equipment or applications.

In the event that customer uses the product for design-in and use in automotive applications to automotive specifications and standards, customer (a) shall use the product without Nexperia's warranty of the product for such automotive applications, use and specifications, and (b) whenever customer uses the product for automotive applications beyond Nexperia's specifications such use shall be solely at customer's own risk, and (c) customer fully indemnifies Nexperia for any liability, damages or failed product claims resulting from customer design and use of the product for automotive applications beyond Nexperia's standard warranty and Nexperia's product specifications.

Translations — A non-English (translated) version of a document is for reference only. The English version shall prevail in case of any discrepancy between the translated and English versions.

Trademarks

Notice: All referenced brands, product names, service names and trademarks are the property of their respective owners.

Contents

1. General description	1
2. Features and benefits	1
3. Applications	1
4. Ordering information	2
5. Marking	2
6. Block diagram	2
7. Functional diagram	3
8. Pinning information	4
8.1. Pinning.....	4
8.2. Pin description.....	5
9. Functional description	5
9.1. Level translator.....	5
9.2. Enable and direction control.....	6
9.3. Feedback clock channel.....	6
9.4. EMI filter.....	6
9.5. ESD protection.....	6
9.6. Pin and channel naming.....	6
10. Limiting values	7
11. Recommended operating conditions	7
12. Static characteristics	8
13. Dynamic characteristics	9
13.1. Level translator.....	9
14. Application information	12
14.1. PCB design guidelines.....	12
15. Design and assembly recommendations	13
15.1. PCB design guidelines.....	13
15.2. PCB assembly guidelines for Pb-free soldering.....	13
16. Package outline	15
17. Abbreviations	17
18. Revision history	17
19. Legal information	18

© Nexperia B.V. 2024. All rights reserved

For more information, please visit: <http://www.nexperia.com>
 For sales office addresses, please send an email to: salesaddresses@nexperia.com
 Date of release: 31 July 2024

Looking for pricing, stock, or lifecycle information?

Click below to explore more details on WIN SOURCE:

 [View NXV55UNR on WIN SOURCE](#)

 [Nexperia USA Inc. Information](#)

Optimize Your Supply Chain with WIN SOURCE Solutions

-  Global Sourcing Solution
-  Obsolete Management
-  Cost Control Management
-  Shortage Management
-  Alternative Solution
-  Excess Inventory Management