



**THE DATASHEET OF
SI-46004-F**



TPS25983 2.7V to 26V, 2.7mΩ, 20A Integrated Hot-Swap With 1.5% Accurate Load Current Monitoring and Adjustable Transient Fault Management

1 Features

- Wide input voltage range: 2.7V to 26V
 - 30V absolute maximum
- Low on-resistance: $R_{ON} = 2.7\text{m}\Omega$ typical
- Adjustable current limit threshold
 - Range: 2A to 20A
 - Accuracy: $\pm 8\%$ (typical for $I_{LIM} > 5\text{A}$)
- Circuit breaker and current limiter options
- Adjustable overcurrent blanking timer
 - Handles load transients without tripping
- Accurate current monitor output
 - $\pm 1.5\%$ (typical at 25°C for $I_{OUT} > 3\text{A}$)
 - $\pm 3\%$ (maximum for $I_{OUT} > 3\text{A}$)
- User configurable fault response
 - Latch-off or auto-retry
 - Number of retries (finite or indefinite)
 - Delay between retries
- Robust short-circuit protection
 - Fast-trip response time $< 400\text{ns}$ typical
 - Immune to line transients – no nuisance tripping
- Adjustable output slew rate (dVdt) control
- Option to drive external FET for reverse current blocking in disabled/OFF state
- Adjustable undervoltage lockout
- Adjustable overvoltage lockout
- Integrated overtemperature protection
- Power good indication
- Small footprint: 4mm × 4mm QFN package

2 Applications

- Hot-swap, hot-plug
- Power multiplexing
- [Server standby rail](#), PCIe riser, [add-on card](#), and fan module protection
- [Router](#) and [switch](#) optical module protection
- [Industrial PC](#)
- [Cordless power tool charger](#)

3 Description

The TPS25983 family of eFuses is a highly-integrated circuit protection and power management device in a small package. The devices are operational over a wide input voltage range. A single part caters to low-voltage systems needing minimal I*R voltage drop as well as higher voltage, high current systems needing low power dissipation. The TPS25983 family is a robust defense against overloads, short-circuits,

voltage surges, reverse current, and excessive inrush current.

Overvoltage events are limited by internal cutoff circuits with user adjustable overvoltage threshold.

Multiple device options exist to choose between the response to overcurrent conditions, circuit breaker, or active current limiter. The overcurrent limit threshold can be set with a single external resistor. The devices intelligently manage the overcurrent response by distinguishing between transient events and actual faults, thereby allowing the system to function uninterrupted during line and load transients without compromising on the robustness of the protection against faults. The device can be configured to stay latched-off or retry automatically after a fault shutdown. The number of auto-retries as well as the retry delay are configurable with capacitors. This feature enables remote systems to automatically recover from temporary faults while making sure that the power supplies are not stressed indefinitely due to a persistent fault.

The devices provide an option to drive an external N-FET connected in series to facilitate reverse current blocking in disabled or OFF state.

Also, the devices integrate an accurate analog load current monitor to provide enhanced system monitoring and diagnostic capabilities.

The TPS25983 devices are available in a small, 4mm × 4mm QFN package. The devices are characterized for operation over a junction temperature range of -40°C to 125°C .

Package Information

PART NUMBER	PACKAGE ⁽¹⁾	PACKAGE SIZE ⁽²⁾
TPS25983	RGE (QFN, 24)	4mm × 4mm

- (1) For all available packages, see the orderable addendum at the end of the data sheet.
- (2) The package size (length × width) is a nominal value and includes pins, where applicable.

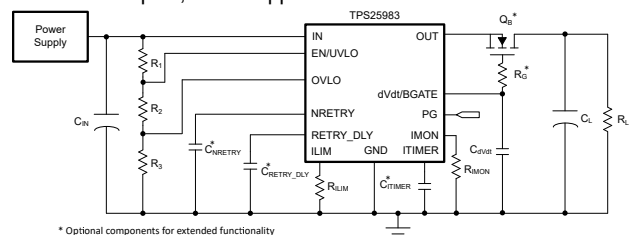

Simplified Schematic



Table of Contents

1 Features	1	7.4 Device Functional Modes.....	30
2 Applications	1	8 Application and Implementation	31
3 Description	1	8.1 Application Information.....	31
4 Device Comparison Table	3	8.2 Typical Application: Standby Power Rail Protection in Datacenter Servers.....	31
5 Pin Configuration and Functions	3	8.3 System Examples.....	37
6 Specifications	5	8.4 Power Supply Recommendations.....	44
6.1 Absolute Maximum Ratings.....	5	8.5 Layout.....	45
6.2 ESD Ratings.....	5	9 Device and Documentation Support	47
6.3 Recommended Operating Conditions.....	6	9.1 Documentation Support.....	47
6.4 Thermal Information.....	6	9.2 Receiving Notification of Documentation Updates...	47
6.5 Electrical Characteristics.....	7	9.3 Support Resources.....	47
6.6 Timing Requirements.....	8	9.4 Trademarks.....	47
6.7 Switching Characteristics.....	9	9.5 Electrostatic Discharge Caution.....	47
6.8 Typical Characteristics.....	10	9.6 Glossary.....	47
7 Detailed Description	16	10 Revision History	47
7.1 Overview.....	16	11 Mechanical, Packaging, and Orderable Information	47
7.2 Functional Block Diagram.....	17		
7.3 Feature Description.....	17		

4 Device Comparison Table

PART NUMBER	OVERCURRENT RESPONSE
TPS259830LNRGE	Active current limiter
TPS259830ONRGE	Circuit breaker

5 Pin Configuration and Functions

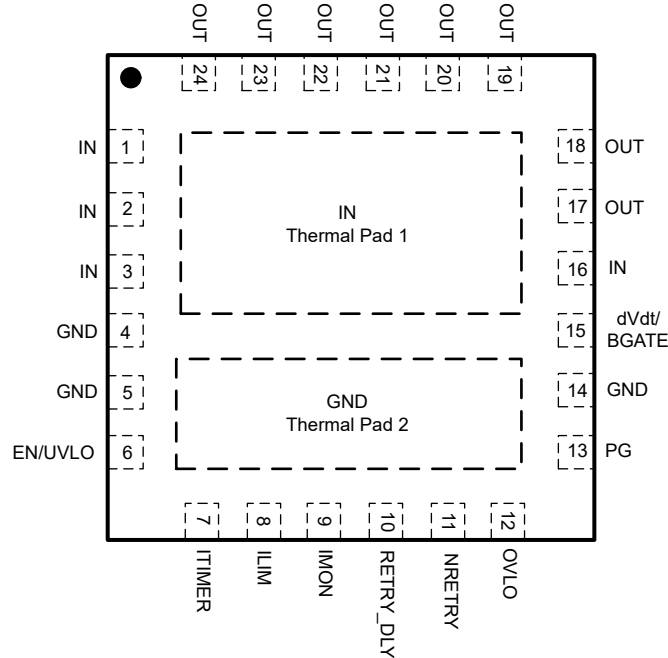

Figure 5-1. RGE Package, 24-Pin QFN (Top View)

Table 5-1. Pin Functions

PIN		TYPE	DESCRIPTION
NAME	NO.		
OUT	17, 18, 19, 20, 21, 22, 23, 24	Power	Power output
IN	1, 2, 3, 16, Pad 1	Thermal / power	Power input. The exposed pad must be soldered to input power plane uniformly to provide proper heat dissipation and to maintain optimal current distribution through the device.
GND	4, 5, 14, Pad 2	Ground	Connect to system ground plane
EN/UVLO	6	Analog input	Active high enable for the device. A resistor divider on this pin from input supply to GND can be used to adjust the undervoltage lockout threshold. Refer to Section 7.3.1 for more details. Do not leave floating.
ITIMER	7	Analog output	A capacitor from this pin to GND sets the overcurrent blanking interval during which the output current can temporarily exceed set current limit (but lower than fast-trip threshold) before the device overcurrent response takes action. Leave this pin open for fastest response to overcurrent events. Refer to Table 7-1 for more details.
ILIM	8	Analog output	An external resistor from this pin to GND sets the output current limit threshold and fast trip threshold. Do not leave floating.
IMON	9	Analog output	Analog output load current monitor. This pin sources a current proportional to the load current. This pin can be converted to a voltage signal by connecting an appropriate resistor from this pin to GND.
RETRY_DLY	10	Analog output	A capacitor from this pin to GND sets the time period that has to elapse after a fault shutdown before the device attempts to restart automatically. Connect this pin to GND for latch-off operation (no auto-retries) after a fault. Refer to Section 7.3.8 for more details.

Table 5-1. Pin Functions (continued)

PIN		TYPE	DESCRIPTION
NAME	NO.		
NRETRY	11	Analog output	A capacitor from this pin to GND sets the number of times the part attempts to restart automatically after shutdown due to fault. Connect this pin to GND if the part needs to retry indefinitely. Refer to Section 7.3.8 for more details.
OVLO	12	Analog input	A resistor divider on this pin from input supply to GND can be used to adjust the overvoltage lockout threshold. Refer to Section 7.3.2 for more details. Do not leave floating.
PG	13	Digital output	Active high Power Good indication. This pin is asserted when the FET is fully enhanced and output has reached maximum voltage. This pin is an open drain output that requires an external pullup resistor to an external supply. This pin remains logic low when $V_{IN} < V_{UVP}$. Refer to Section 7.3.6 for more details.
dVdt/BGATE	15	Analog output	A capacitor from this pin to GND sets the output turn on slew rate. Leave this pin floating for the fastest slew rate during start up. This pin can also be used to drive an external FET to implement reverse current blocking in OFF/disabled state. Please refer to Section 7.3.7 for more details.

6 Specifications

6.1 Absolute Maximum Ratings

over operating free-air temperature range (unless otherwise noted)⁽¹⁾

Parameter		Pin	MIN	MAX	UNIT
V _{IN}	Maximum input voltage range	IN	-0.3	30	V
V _{OUT}	Maximum output voltage range	OUT	-0.8	min (30, V _{IN} + 0.3)	V
V _{EN/UVLO}	Maximum Enable pin voltage range	EN/UVLO	-0.3	7	V
V _{OVLO}	Maximum OVLO pin voltage range	OVLO		7	V
V _{DVDT}	Maximum dVdT/BGATE pin voltage range	dVdT/BGATE	Internally Limited		V
V _{PG}	Maximum PG pin voltage range	PG	-0.3	7	V
V _{ITIMER}	Maximum ITIMER pin voltage range	ITIMER	Internally Limited		V
V _{NRETRY}	Maximum NRETRY pin voltage range	NRETRY	Internally Limited		V
V _{RETRY_DLY}	Maximum RETRY_DLY pin voltage range	RETRY_DLY	Internally Limited		V
I _{MAX}	Maximum continuous switch current	IN to OUT	Internally Limited		A
T _J	Maximum junction temperature		Internally Limited		°C
T _{LEAD}	Maximum soldering temperature			300	°C
T _{stg}	Maximum storage temperature		-65	150	°C

- (1) Operation outside the Absolute Maximum Ratings may cause permanent device damage. Absolute Maximum Ratings do not imply functional operation of the device at these or any other conditions beyond those listed under Recommended Operating Conditions. If used outside the Recommended Operating Conditions but within the Absolute Maximum Ratings, the device may not be fully functional, and this may affect device reliability, functionality, performance, and shorten the device lifetime.

6.2 ESD Ratings

			VALUE	UNIT
V _(ESD)	Electrostatic discharge	Human body model (HBM), per ANSI/ESDA/ JEDEC JS-001 ⁽¹⁾	± 2000	V
		Charged device model (CDM), per ANSI/ESDA/ JEDEC JS-002 ⁽²⁾	± 1000	

- (1) JEDEC document JEP155 states that 500-V HBM allows safe manufacturing with a standard ESD control process.
(2) JEDEC document JEP157 states that 250-V CDM allows safe manufacturing with a standard ESD control process.

6.3 Recommended Operating Conditions

over operating free-air temperature range (unless otherwise noted)

Parameter		Pin	MIN	MAX	UNIT
V _{IN}	Input voltage range	IN	2.7	26	V
V _{OUT}	Output voltage range	OUT	V _{IN} + 0.3		V
V _{EN/UVLO}	Enable pin voltage range	EN/UVLO	6 ⁽¹⁾		V
V _{OVLO}	OVLO pin voltage range	OVLO	6 ⁽¹⁾		V
V _{DVDT}	dVdT/BGATE pin capacitor voltage rating	dVdT/BGATE	V _{IN} + 10		V
V _{PG}	PG pin voltage range	PG	6 ⁽²⁾		V
V _{ITIMER}	ITIMER pin capacitor voltage rating	ITIMER	4		V
V _{NRETRY}	NRETRY pin capacitor voltage rating	NRETRY	4		V
V _{RETRY_DLY}	RETRY_DLY pin capacitor voltage rating	RETRY_DLY	4		V
R _{ILIM}	ILIM pin resistor value range	ILIM	74	1650	Ω
I _{MAX}	Continuous switch current	IN to OUT	18		A
T _J	Junction temperature range		-40	125	°C

- (1) Pulling up the EN pin to IN directly is okay for supply voltage below 6 V. Use an appropriate resistor divider between IN, EN, and GND for voltages greater than 6 V to make sure the voltage at the EN pin is within the specified limits.
- (2) Pulling up the PG pin to IN/OUT directly is okay for supply voltage below 6 V. For voltages greater than 6 V, step down the power supply to make sure the voltage at the PG pin is within the specified limits.

6.4 Thermal Information

THERMAL METRIC ^{(1) (2)}		TPS25983X	UNIT
		RGE (QFN)	
		24 PINS	
R _{θJA}	Junction-to-ambient thermal resistance	34.6	°C/W
R _{θJC(top)}	Junction-to-case (top) thermal resistance	36.7	°C/W
R _{θJB}	Junction-to-board thermal resistance	11.2	°C/W
Ψ _{JT}	Junction-to-top characterization parameter	3	°C/W
Ψ _{JB}	Junction-to-board characterization parameter	11.2	°C/W
R _{θJC(bot)}	Junction-to-case (bottom) thermal resistance	1.6	°C/W

- (1) For more information about traditional and new thermal metrics, see the [Semiconductor and IC Package Thermal Metrics](#) application report.
- (2) Based on simulations conducted with the device mounted on a JEDEC 4-layer PCB (2s2p) with minimum recommended pad size (2 oz Cu) and 3x2 via array.

6.5 Electrical Characteristics

(Test conditions unless otherwise noted) $-40^{\circ}\text{C} \leq T_J \leq 125^{\circ}\text{C}$, $V_{IN} = 12\text{ V}$, $V_{EN/UVLO} = 2\text{ V}$, $R_{ILIM} = 1650\ \Omega$, $C_{dVdT} = \text{Open}$, $\text{OUT} = \text{Open}$. All voltages referenced to GND.

PARAMETER		TEST CONDITIONS	MIN	TYP	MAX	UNIT
INPUT SUPPLY (IN)						
V_{IN}	Input voltage range		2.7		26	V
$I_{Q(ON)}$	IN quiescent current	$V_{EN} \geq V_{UVLO(R)}$		800	1000	μA
$I_{Q(OFF)}$	IN OFF current	$V_{SD(F)} < V_{EN} < V_{UVLO}$		204	300	μA
I_{SD}	IN shutdown current	$V_{EN} < V_{SD(F)}$		3.7	15	μA
V_{UVP}	IN undervoltage protection threshold	V_{IN} rising		2.53		V
		V_{IN} falling		2.42		V
OUTPUT CURRENT MONITOR (IMON)						
G_{IMON}	Current monitor gain ($I_{IMON}:I_{OUT}$)	$3\text{ A} \leq I_{OUT} \leq \min(18\text{ A}, I_{LIM})$	235.29	243	249.63	$\mu\text{A/A}$
OUTPUT CURRENT LIMIT (ILIM)						
I_{LIM}	I_{OUT} current limit threshold	$R_{ILIM} = 773\ \Omega$	1.526	2.03	2.48	A
		$R_{ILIM} = 300\ \Omega$	4.36	4.98	5.66	A
		$R_{ILIM} = 182\ \Omega$	7.1	8.13	8.96	A
		$R_{ILIM} = 100\ \Omega$	12.6	14.729	16.23	A
		$R_{ILIM} = 84\ \Omega$	16.3	17.526	18.8	A
		$R_{ILIM} = \text{Open}$			0	
I_{CB}	I_{OUT} circuit-breaker threshold during ILIM pin short to GND condition (Single point failure)	$R_{ILIM} = \text{Short to GND}$, $T_J = 25^{\circ}\text{C}$			15	A
V_{FB}	V_{OUT} voltage threshold for current limit foldback			0.91		V
I_{FT}	Short-circuit fast trip threshold (Steady-state)	PG asserted		86.4		A
I_{SC}	Short-circuit fast trip threshold (Inrush)	PG de-asserted		210		% I_{LIM}
ON-RESISTANCE (IN - OUT)						
R_{ON}	IN-OUT ON resistance	$T_J = 25^{\circ}\text{C}$, $I_{OUT} = 2\text{ A}$		2.7	3.2	m Ω
		$T_J = -40$ to 125°C , $I_{OUT} = 2\text{ A}$			4.5	m Ω
ENABLE / UNDERVOLTAGE LOCKOUT (EN/UVLO)						
$V_{UVLO(R)}$	EN/UVLO pin voltage threshold to turn OFF FET	V_{EN} rising	1.18	1.2	1.23	V
$V_{UVLO(F)}$		V_{EN} falling	1.08	1.1	1.13	V
$V_{SD(F)}$	EN/UVLO pin voltage threshold for lowest shutdown current	V_{EN} falling	0.59	0.8		V
I_{ENLKG}	EN/UVLO pin leakage current				0.13	μA
OVERVOLTAGE PROTECTION (OVLO)						
$V_{OV(R)}$	OVLO pin voltage threshold	V_{OVLO} rising	1.1	1.21	1.25	V
$V_{OV(F)}$		V_{OVLO} falling	1.08	1.1	1.125	V
POWER GOOD INDICATION (PG)						
V_{PGD}	PG pin low voltage (PG de-asserted)	$V_{IN} < V_{UVP(F)}$, $V_{EN} < V_{SD(F)}$, $I_{PG} = 26\ \mu\text{A}$		651	786	mV
		$V_{IN} = 3.3\text{ V}$, $I_{PG} \leq 5\text{ mA}$		320		mV
		$V_{IN} \geq 5\text{ V}$, $I_{PG} \leq 5\text{ mA}$		90		mV
I_{PGLKG}	PG pin leakage current (PG asserted)	PG pulled up to 5 V through 10 k Ω			1.7	μA
$R_{ON(PGA)}$	R_{ON} when PG is asserted			4.2	6.4	m Ω

6.5 Electrical Characteristics (continued)

(Test conditions unless otherwise noted) $-40^{\circ}\text{C} \leq T_J \leq 125^{\circ}\text{C}$, $V_{IN} = 12\text{ V}$, $V_{EN/UVLO} = 2\text{ V}$, $R_{ILIM} = 1650\ \Omega$, $C_{dVdT} = \text{Open}$, $\text{OUT} = \text{Open}$. All voltages referenced to GND.

PARAMETER		TEST CONDITIONS	MIN	TYP	MAX	UNIT
V_{PGTHD}	$V_{IN} - V_{OUT}$ threshold when PG is de-asserted		0.217	0.326	0.451	V
AUTO-RETRY DELAY INTERVAL (RETRY_DLY)						
$V_{RETRY_DLY(R)}$	RETRY_DLY oscillator comparator threshold		0.95	1.1	1.19	V
$V_{RETRY_DLY(F)}$			0.25	0.35	0.43	V
$V_{RETRY_DLY_HYS}$	RETRY_DLY oscillator hysteresis		0.69	0.75	0.81	V
I_{RETRY_DLY}	RETRY_DLY pin bias current		1.7	2.05	3.25	μA
NUMBER OF AUTO-RETRIES (NRETRY)						
$V_{NRETRY(R)}$	NRETRY oscillator comparator threshold		0.95	1.1	1.19	V
$V_{NRETRY(F)}$			0.24	0.35	0.445	V
V_{NRETRY_HYS}	NRETRY oscillator hysteresis		0.7	0.75	0.811	V
I_{NRETRY}	NRETRY pin bias current		1.7	2.05	3.25	μA
CURRENT FAULT TIMER (ITIMER)						
I_{ITIMER}	ITIMER pin discharge current	$I_{FT} > I_{OUT} > I_{LIM}$	1.48	2.1	2.65	μA
R_{ITIMER}	ITIMER internal pull-up resistance	$I_{OUT} < I_{LIM}$	15	23	33	$\text{k}\Omega$
V_{INT}	ITIMER pin internal pull-up voltage	$I_{OUT} < I_{LIM}$	2.3	2.5	2.7	V
ΔV_{ITIMER}	ITIMER discharge differential voltage threshold	$I_{FT} > I_{OUT} > I_{LIM}$, ITIMER voltage falling	0.8	0.98	1.15	V
OVERTEMPERATURE PROTECTION						
TSD	Thermal shutdown threshold	T_J Rising		150		$^{\circ}\text{C}$
TSDHys	Thermal shutdown hysteresis	T_J Falling		10		$^{\circ}\text{C}$
dVdT/BGATE						
I_{dVdt}	dVdT/BGATE pin charging current during inrush		3.6	4.76	6	μA

6.6 Timing Requirements

PARAMETER		TEST CONDITIONS	MIN	TYP	MAX	UNIT
t_{OVP}	Overvoltage protection response time ⁽¹⁾	$V_{OVLO} > V_{OV(R)}$ to $V_{OUT}\downarrow$		2.6		μs
t_{LIM}	Current limit response time (TPS259830L variants) ⁽²⁾	$I_{OUT} > I_{LIM} + 30\%$ and ITIMER expired to $I_{OUT} \leq I_{LIM}$		588		μs
t_{SC}	Short-circuit fast-trip response time ⁽³⁾	OUT shorted to GND to $I_{OUT}\downarrow$		400		ns
t_{PGD}	PG assertion/de-assertion de-glitch ⁽⁴⁾	$V_G > (V_{IN} + 3.6\text{ V})$ to $\text{PG}\uparrow$ or $(V_{IN} - V_{OUT}) > V_{PGTHD}$ to $\text{PG}\downarrow$		120		μs

(1) Please refer to Fig. 8-3

(2) Please refer to Fig. 8-5

(3) Please refer to Fig. 8-6

(4) Please refer to Fig. 8-7

6.7 Switching Characteristics

The output rising slew rate is internally controlled and constant across the entire operating voltage range to ensure the turn on timing is not affected by the load conditions. The rising slew rate can be adjusted by adding capacitance from the dVdt pin to ground. As C_{dVdt} is increased it will slow the rising slew rate (SR). See Slew Rate and Inrush Current Control (dVdt) section for more details. The Turn-Off Delay and Fall Time, however, are dependent on the RC time constant of the load capacitance (C_{OUT}) and Load Resistance (R_L). The Switching Characteristics are only valid for the power-up sequence where the supply is available in steady state condition and the load voltage is completely discharged before the device is enabled. Typical Values are taken at $T_J = 25^\circ\text{C}$ unless specifically noted otherwise. $R_L = 3.6\ \Omega$, $C_{OUT} = 1\ \text{mF}$

PARAMETER		V_{IN}	$C_{dVdt} = \text{Open}$	$C_{dVdt} = 3300\text{pF}$	$C_{dVdt} = 6800\text{pF}$	UNIT
SR_{ON}	Output Rising slew rate	2.7 V	2.04	0.84	0.51	V/ms
		12 V	4.58	1.15	0.64	
		26 V	6.98	1.28	0.68	
$t_{D,ON}$	Turn on delay	2.7 V	2.55	3.45	4.55	ms
		12 V	2.35	3.83	5.54	
		26 V	2.16	4.4	6.83	
t_R	Rise time	2.7 V	1.06	2.57	4.23	ms
		12 V	2.097	8.34	14.99	
		26 V	2.98	16.28	30.45	
t_{ON}	Turn on time	2.7 V	3.61	6.02	8.78	ms
		12 V	4.44	12.17	20.53	
		26 V	5.14	20.68	37.28	
$t_{D,OFF}$	Turn off delay	2.7 V	6.5	5.9	6.74	μs
		12 V	6.955	6.5	6.8	
		26 V	6.8	6.94	7.02	

6.8 Typical Characteristics

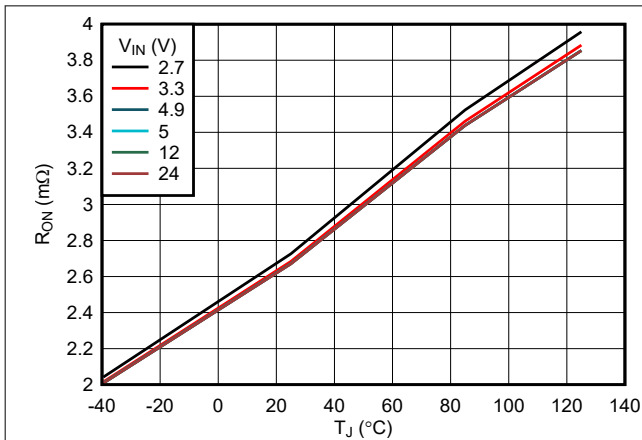

Figure 6-1. ON Resistance vs Temperature

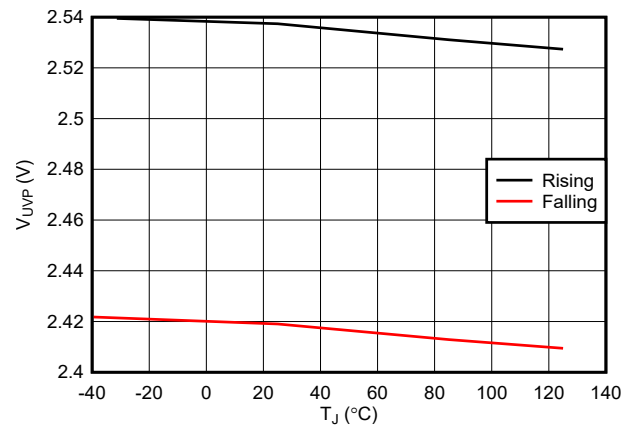

Figure 6-2. Supply UVP Threshold vs Temperature

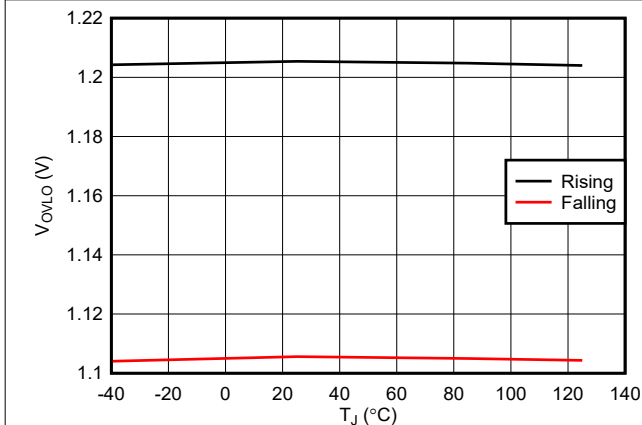

Figure 6-3. OVLO Pin Threshold vs Temperature

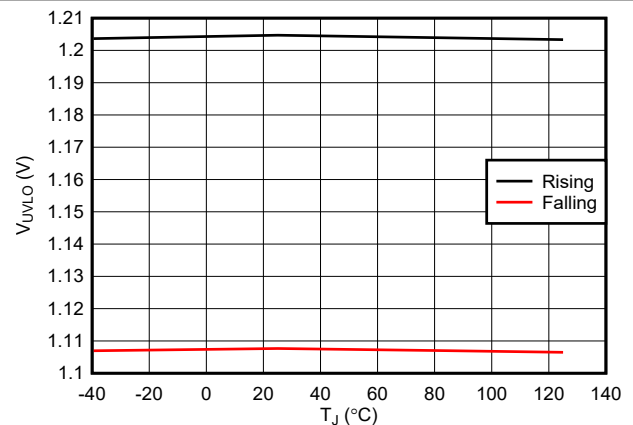

Figure 6-4. EN/UVLO Pin Threshold vs Temperature

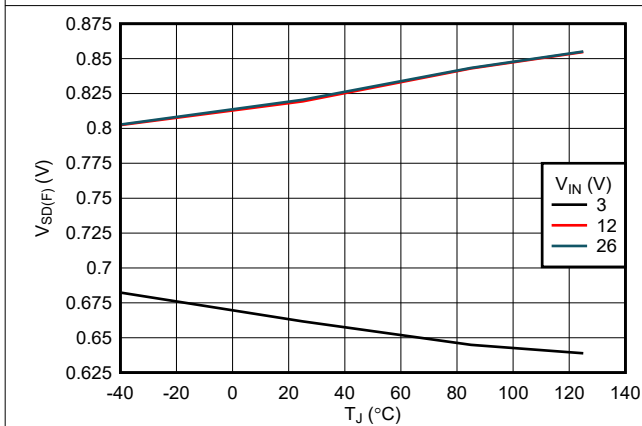

Figure 6-5. EN/UVLO Falling Threshold for Lowest Current Consumption

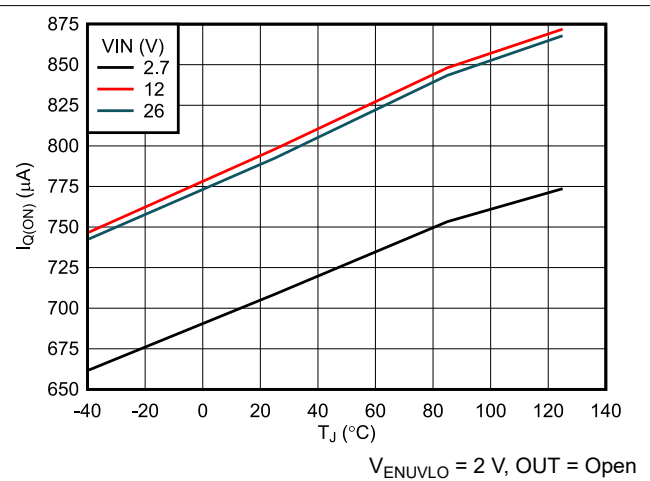

Figure 6-6. Quiescent Current vs Temperature

6.8 Typical Characteristics (continued)

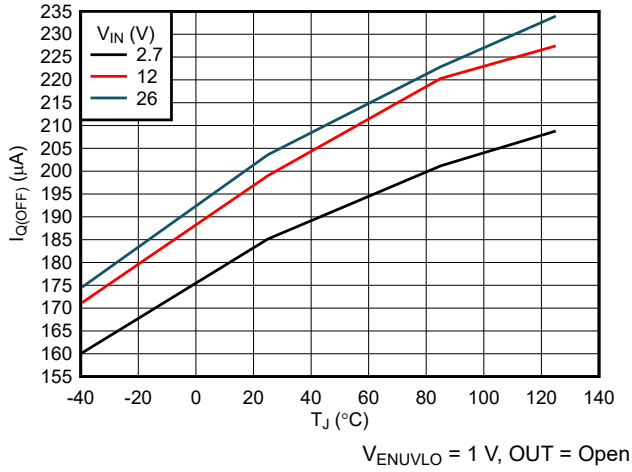

Figure 6-7. Shut-Down Current vs Temperature

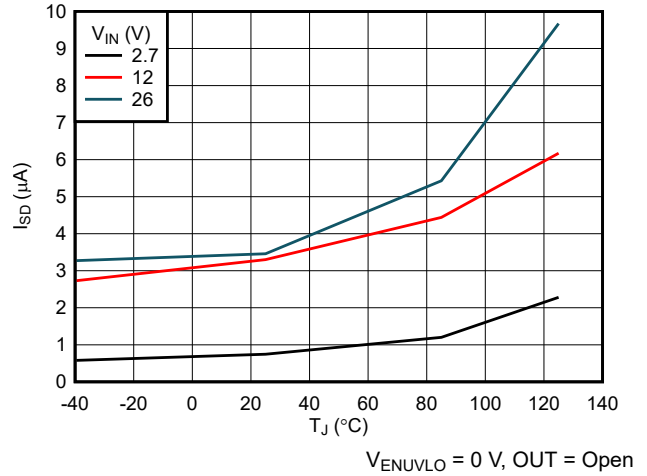

Figure 6-8. Deep Shut-Down Current vs Temperature

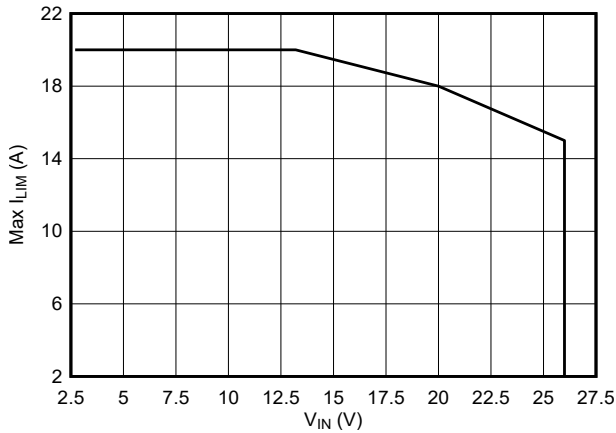

Figure 6-9. Recommended Maximum I_{LIM} Setting For Safe Operation vs Input Voltage

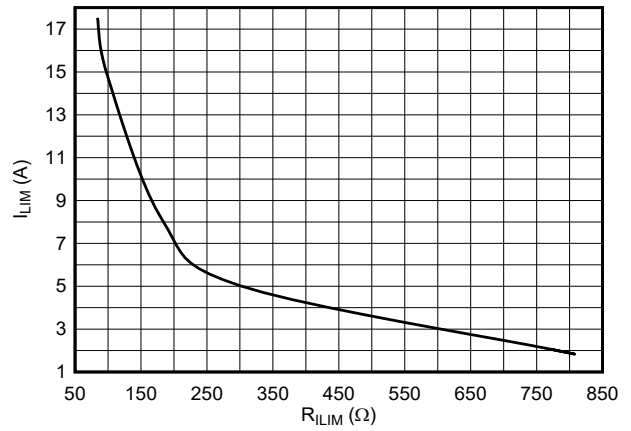

Figure 6-10. Output Current Limit (I_{LIM}) vs R_{ILIM}

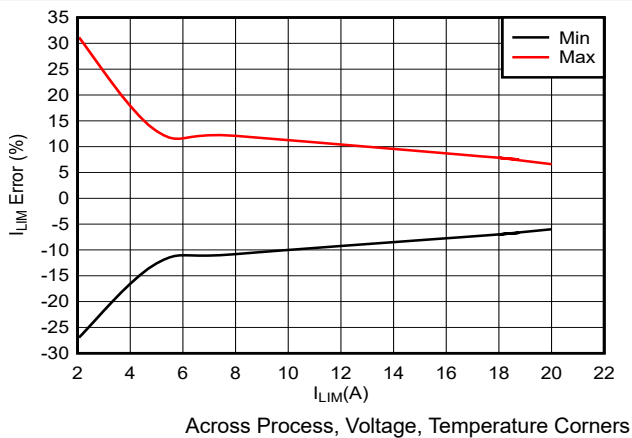

Figure 6-11. Output Current Limit (I_{LIM}) Accuracy

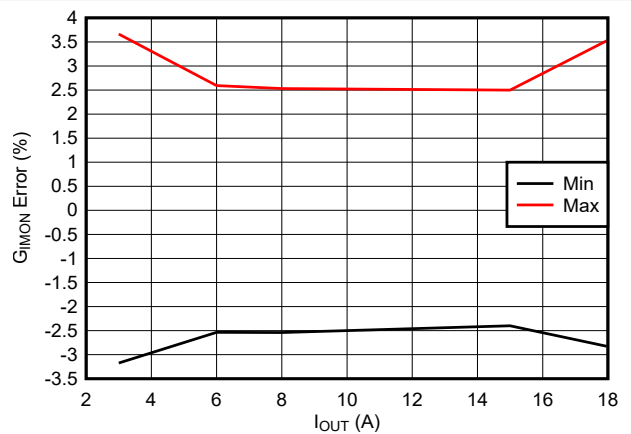

Figure 6-12. Output Current Monitor Gain (G_{IMON}) Accuracy

6.8 Typical Characteristics (continued)

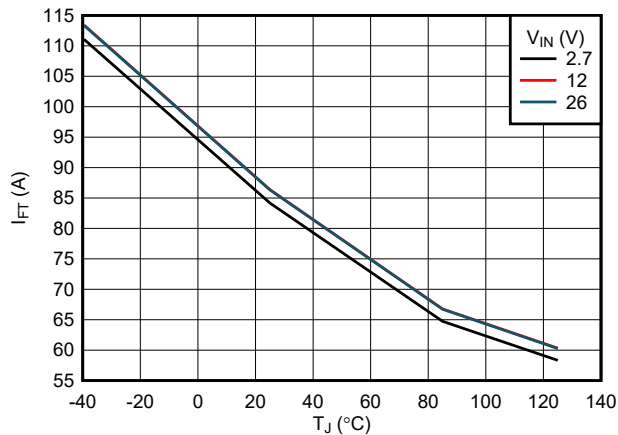
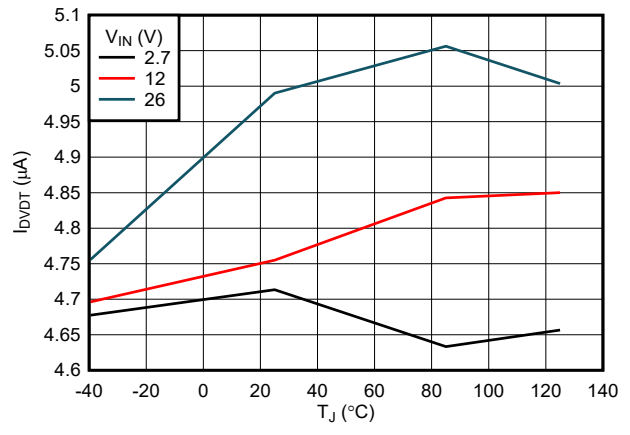
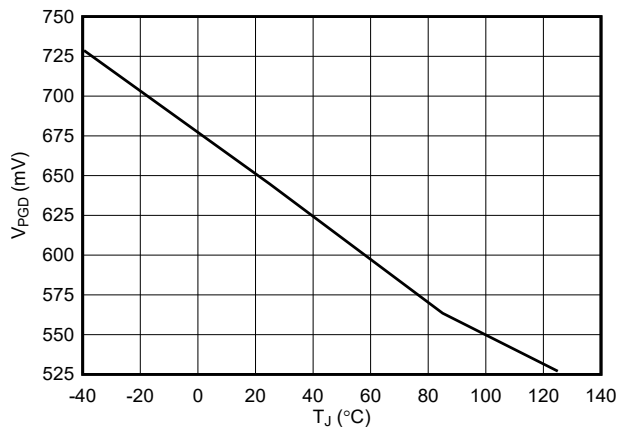

Figure 6-13. Fixed Fast-trip Threshold vs Temperature



V_{IN} = 0 V, I_{PG} = 26 µA

Figure 6-14. DVDT Pin Charging Current vs Temperature



V_{IN} = 0 V, I_{PG} = 26 µA

Figure 6-15. Power Good Output Voltage (De-asserted State) vs Temperature

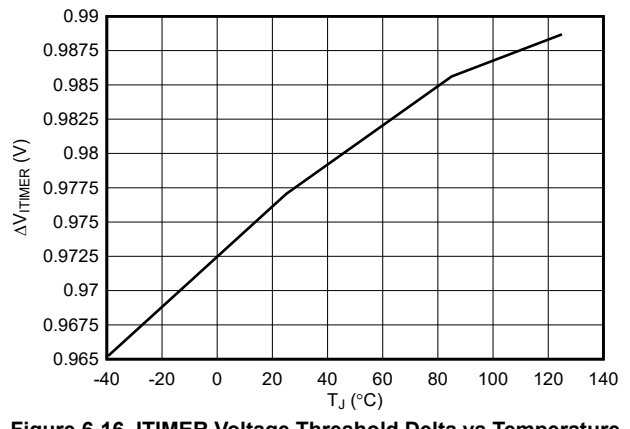

Figure 6-16. ITIMER Voltage Threshold Delta vs Temperature

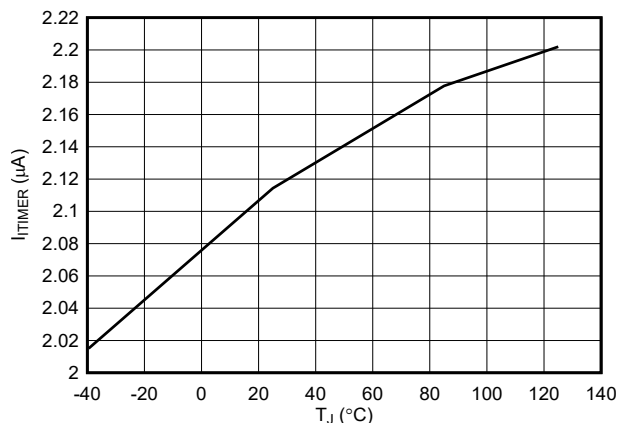

Figure 6-17. ITIMER Discharge Current vs Temperature

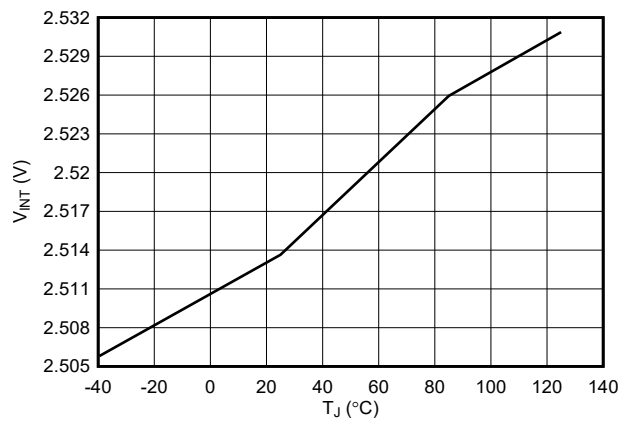

Figure 6-18. ITIMER Internal Pull-up Voltage vs Temperature

6.8 Typical Characteristics (continued)

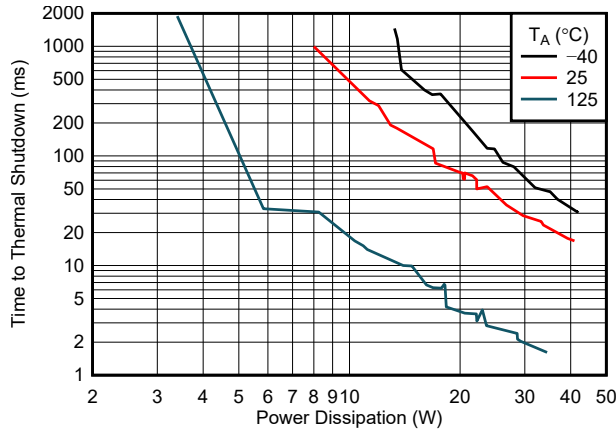

Figure 6-19. Thermal Shutdown Plot - Steady State

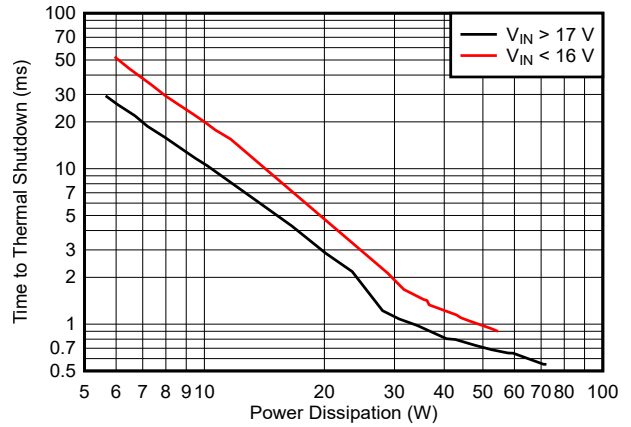

Figure 6-20. Thermal Shutdown Plot - Inrush/Overload

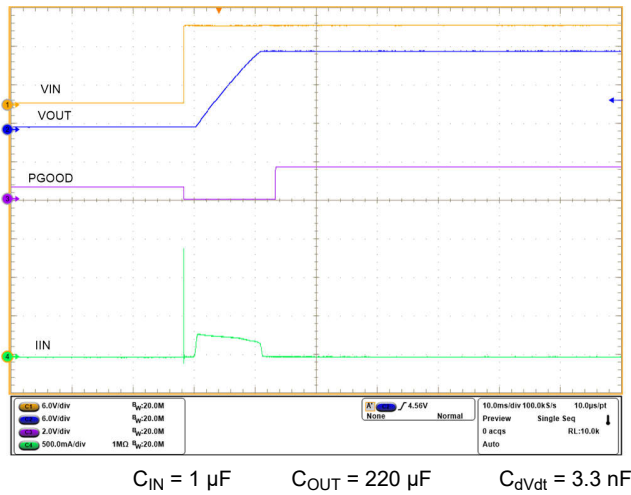

Figure 6-21. Hotplug

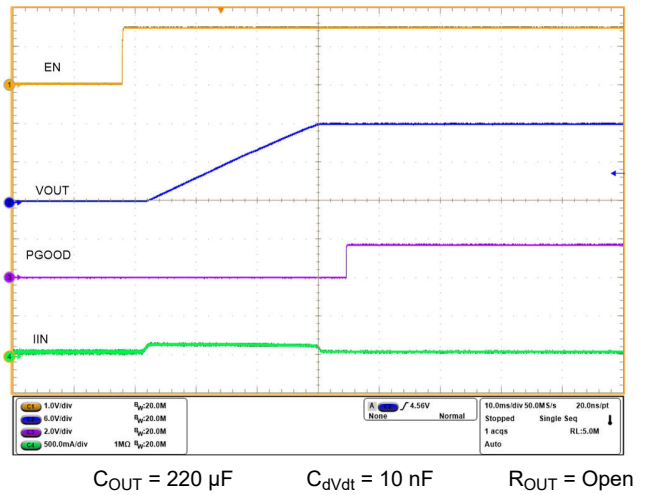

Figure 6-22. Startup With EN - dVdt Limited

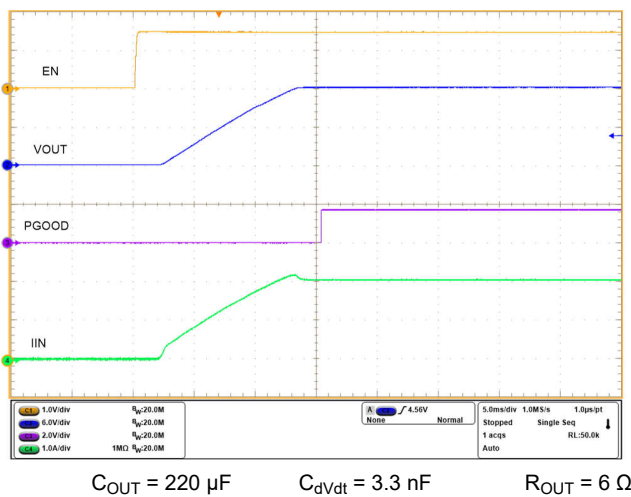

Figure 6-23. Start Up With EN Into Resistive Load - dVdt Limited

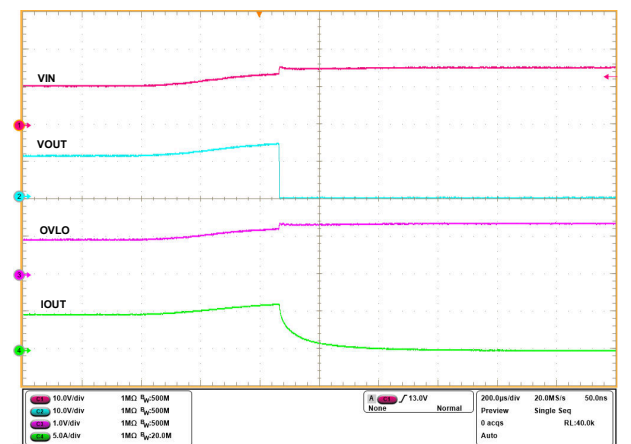
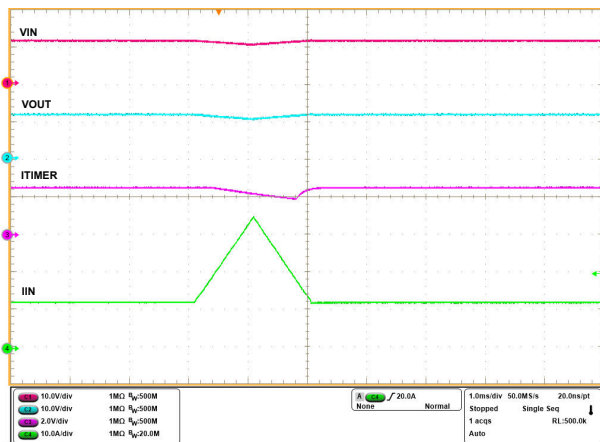

Figure 6-24. Overvoltage Protection

6.8 Typical Characteristics (continued)



$R_{LIM} = 82 \Omega$ $C_{ITIMER} = 4.7 \text{ nF}$

Output load current ramped above the I_{LIM} threshold for short duration without triggering current limit

Figure 6-25. Transient Overcurrent Blanking Timer Response

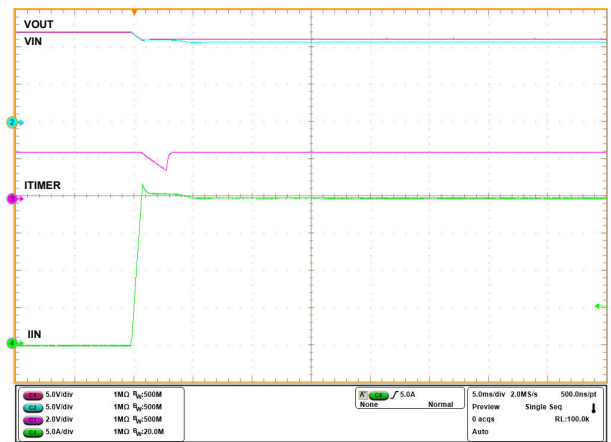

$R_{LIM} = 82 \Omega$ $C_{ITIMER} = 4.7 \text{ nF}$

Output load current ramped above the I_{LIM} threshold beyond the $ITIMER$ duration triggers current limit

Figure 6-26. Steady-state Current Limit Response (TPS259830L Variant)

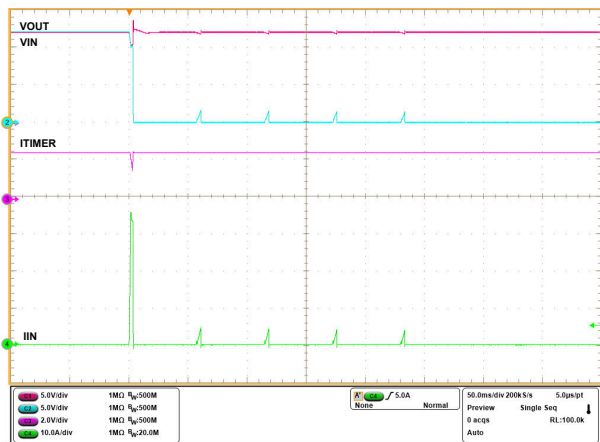

$R_{LIM} = 82 \Omega$ $C_{ITIMER} = 4.7 \text{ nF}$ $C_{RETRY_DLY} = 1 \text{ nF}$,
 $C_{NRETRY} = \text{Open}$

Figure 6-27. Steady-state Current Limit Followed By Thermal Shutdown And Auto-Retry (TPS259830L Variant)

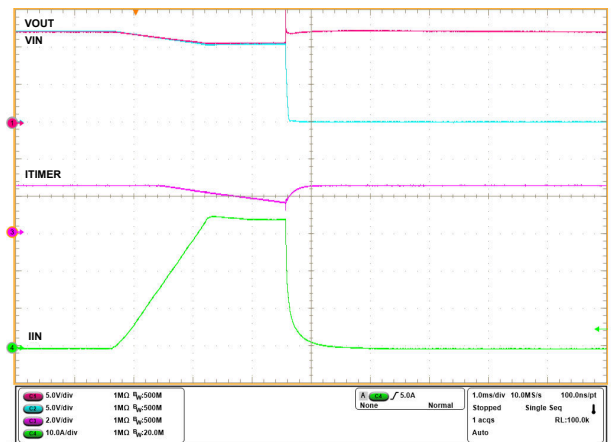

$R_{LIM} = 82 \Omega$ $C_{ITIMER} = 4.7 \text{ nF}$

Output load current ramped above the I_{LIM} threshold beyond the $ITIMER$ duration triggers circuit breaker response

Figure 6-28. Steady-state Circuit Breaker Response (TPS259830O Variant)

6.8 Typical Characteristics (continued)

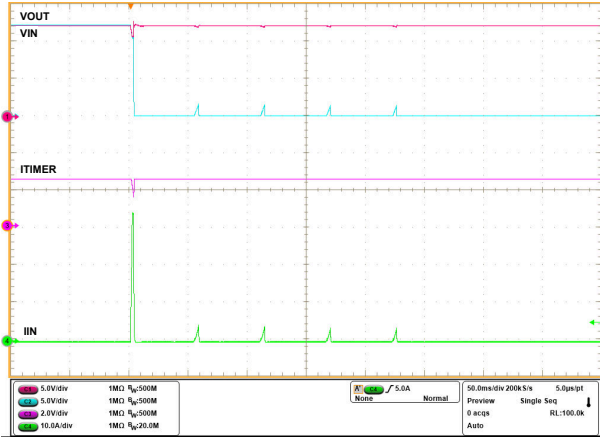

$R_{ILIM} = 82 \Omega$ $C_{ITIMER} = 4.7 \text{ nF}$ $C_{RETRY_DLY} = \text{Open}$,
 $C_{NRETRY} = \text{Open}$

Figure 6-29. Steady-state Circuit Breaker Response Followed By Auto-Retry (TPS259830 Variant)

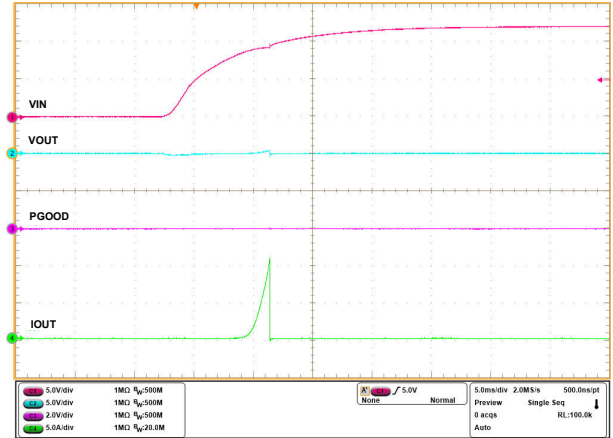

$R_{ILIM} = 82 \Omega$

Figure 6-30. Power Up Into Output Short-Circuit

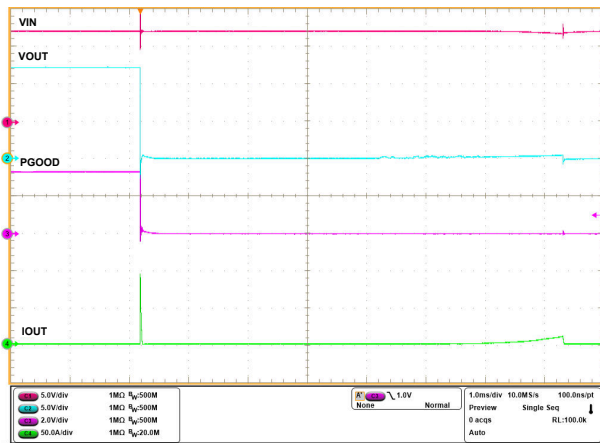

$R_{ILIM} = 82 \Omega$

Figure 6-31. Output Hard Short-Circuit During Steady-state

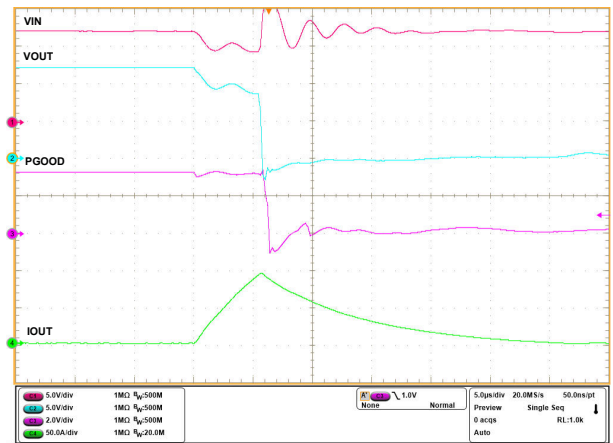

$R_{ILIM} = 82 \Omega$

Figure 6-32. Output Hard Short-Circuit During Steady-state (Zoomed In)

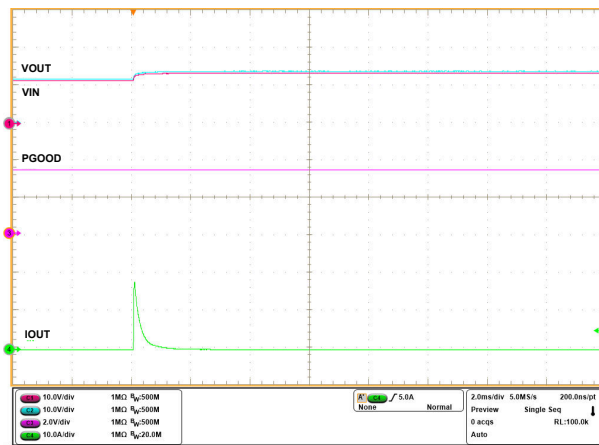

$R_{ILIM} = 82 \Omega$

Figure 6-33. Supply Line Transient Immunity - Input Voltage Step

7 Detailed Description

7.1 Overview

The TPS25983 device is a smart eFuse with integrated power switch that is used to manage load voltage and load current. The device starts operation by monitoring the IN bus. When V_{IN} is above the Undervoltage Protection threshold (V_{UVP}), the device samples the EN/UVLO pin. A high level on this pin enables the internal MOSFET to start conducting and allows current to flow from IN to OUT. When EN/UVLO is held low, the internal MOSFET is turned off.

After a successful start-up sequence, the device actively monitors load current, input voltage, and controls the internal FET to make sure that the user adjustable overcurrent protection threshold (I_{LIM}) is not exceeded and overvoltage spikes are cut-off after spikes cross the user adjustable overvoltage lockout threshold. The device also provides fast protection against severe overcurrent during short-circuit events. This feature keeps the system safe from harmful levels of voltage and current. At the same time, a user-adjustable overcurrent blanking timer allows the system to pass moderate transient peaks in the load current profile without tripping the eFuse. This feature provides a robust protection solution against real faults which is also immune to transients, thereby maintaining maximum system uptime.

The device also relies on a built-in thermal sense circuit to shut down and protect itself in case the device internal temperature (T_J) exceeds the safe operating conditions.

7.2 Functional Block Diagram

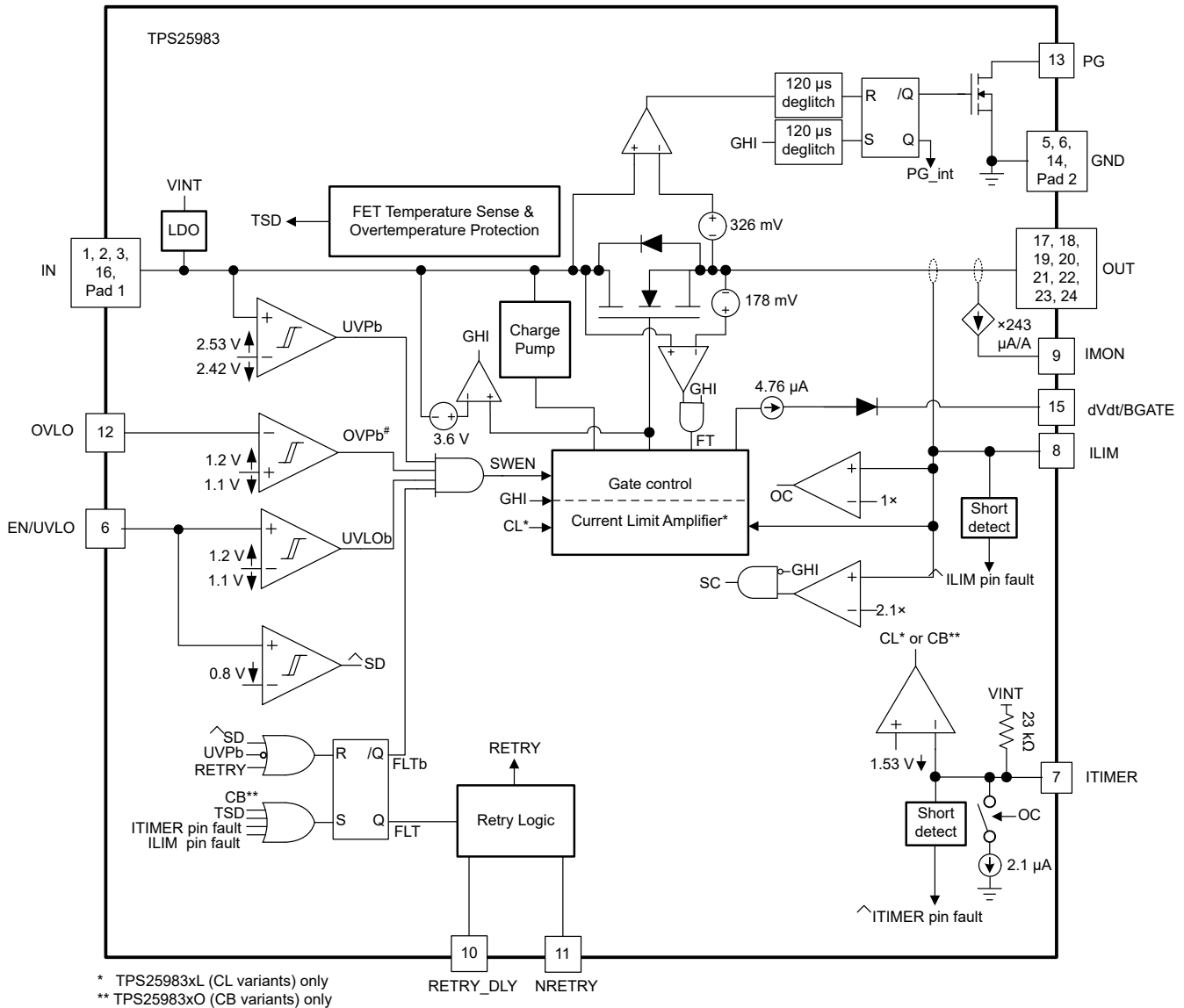

7.3 Feature Description

The TPS25983 eFuse is a compact, feature rich power management device that provides detection, protection and indication in the event of system faults.

7.3.1 Undervoltage Protection (UVLO and UVP)

The TPS25983 implements Undervoltage Protection on IN to turn off the output in case the applied voltage becomes too low for the downstream load or the device to operate correctly. The Undervoltage Protection has a default internal threshold of V_{UVP} . If needed, setting a user defined Undervoltage Protection threshold higher than V_{UVP} using the UVLO comparator on the EN/UVLO pin is also possible. Figure 7-1 and Equation 1 show how a resistor divider from supply to GND can be used to set the UVLO set point for a given voltage supply level.

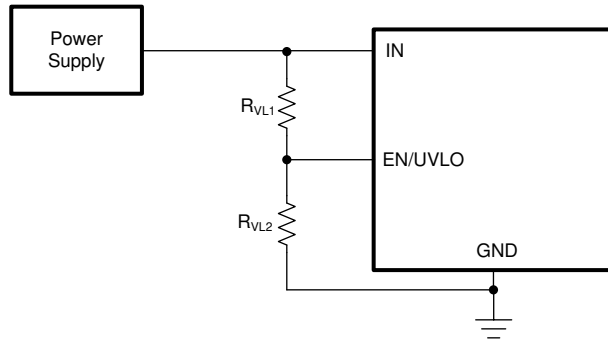

Figure 7-1. Adjustable Supply UVLO Threshold

$$V_{IN(UV)} = V_{UVLO(F)} \times \frac{R_{VL1} + R_{VL2}}{R_{VL2}} \quad (1)$$

The resistors must be sized large enough to minimize the constant leakage from supply to ground through the resistor divider network. At the same time, keep the current through the resistor network sufficiently larger (20x) than the leakage current on the EN/UVLO pin to minimize the error in the resistor divider ratio.

7.3.2 Overvoltage Protection (OVP)

The TPS25983 allows the user to implement overvoltage lockout to protect the load from input overvoltage conditions. The OVLO comparator on the OVLO pin allows the overvoltage protection threshold to be adjusted to a user defined value. After the voltage at the OVLO pin crosses the OVLO rising threshold $V_{OV(R)}$, the device turns off the power to the output. Thereafter, the devices wait for the voltage at the OVLO pin to fall below the OVLO falling threshold $V_{OV(F)}$ before the output power is turned ON again. The rising and falling thresholds are slightly different to provide hysteresis. [Figure 7-2](#) and [Equation 2](#) show how a resistor divider can be used to set the OVLO set point for a given voltage supply.

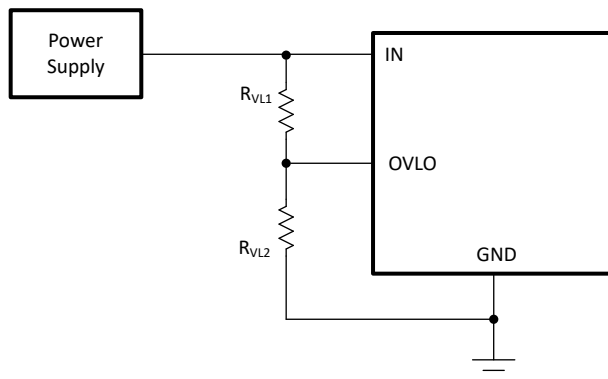

Figure 7-2. Adjustable Supply OVLO Threshold

$$V_{IN(OV)} = V_{OV(F)} \times \frac{R_{VL1} + R_{VL2}}{R_{VL2}} \quad (2)$$

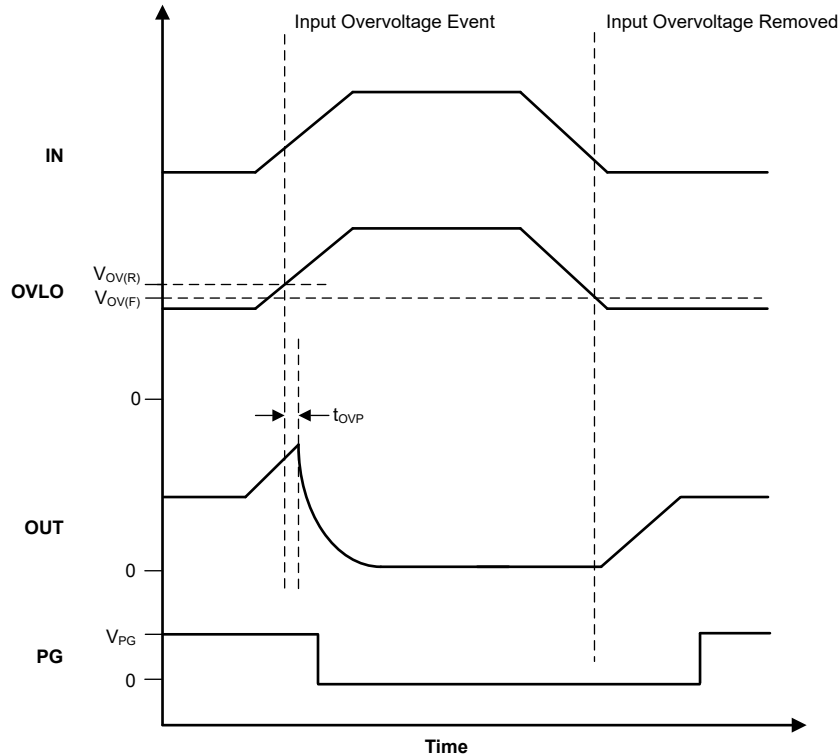

Figure 7-3. Overtoltage Response

While recovering from a OVLO event, the TPS25983 starts up with inrush control (dVdt).

7.3.3 Inrush Current, Overcurrent, and Short-Circuit Protection

TPS25983 devices incorporate three levels of protection against overcurrent:

- Adjustable slew rate (dVdt) for inrush current control
- Adjustable overcurrent protection (with adjustable blanking timer) - Circuit Breaker or Active Current Limiter to protect against soft overload conditions
- Fixed fast-trip response to quickly protect against severe overcurrent (short-circuit) faults

7.3.3.1 Slew Rate and Inrush Current Control (dVdt)

During hot-plug events or while trying to charge a large output capacitance, there can be a large inrush current. If the inrush current is not controlled, it can damage the input connectors and/or cause the system power supply to droop leading to unexpected restarts elsewhere in the system. The TPS25983 provides integrated output slew rate (dVdt) control to manage the inrush current during start-up. The inrush current is directly proportional to the load capacitance and rising slew rate. The following equation can be used to calculate the slew rate (SR) required to limit the inrush current (I_{INRUSH}) for a given load capacitance (C_{OUT}):

$$SR(V/ms) = \frac{I_{INRUSH}(mA)}{C_{OUT}(\mu F)} \quad (3)$$

An external capacitance can be connected to the dVdt/BGATE pin to control the rising slew rate and lower the inrush current during turn on. The required C_{dVdt} capacitance to produce a given slew rate can be calculated using the following formula:

$$C_{dVdt}(pF) = \frac{4600}{SR(V/ms)} \quad (4)$$

The fastest output slew rate is achieved by leaving the dVdt/BGATE pin open.

7.3.3.2 Circuit Breaker

The TPS25983xO (circuit breaker) variants respond to output overcurrent conditions by turning off the output after a user adjustable transient fault blanking interval. During steady-state operation, if the load current exceeds a user-adjustable overcurrent threshold (I_{LIM}) set by the ILIM pin resistor (R_{ILIM}), but lower than the fast-trip threshold (I_{FT}), the device starts discharging the ITIMER pin capacitor using an internal pull-down current (I_{ITIMER}). If the load current drops below the overcurrent before the ITIMER capacitor drops by ΔV_{ITIMER} , the circuit-breaker action is not engaged and the ITIMER is reset by pulling up to V_{INT} internally. This behavior allows short transient overcurrent pulses to pass through the device without tripping the circuit. If the overcurrent condition persists, the ITIMER capacitor continues to discharge and once the capacitor falls by ΔV_{ITIMER} , the circuit-breaker action turns off the FET immediately. The following equation can be used to calculate the R_{ILIM} value for a desired overcurrent threshold.

$$R_{ILIM}(\Omega) = \frac{1460}{I_{LIM}(A) - 0.11} \quad (5)$$

Note

Leaving the ILIM pin Open sets the overcurrent threshold to zero and causes the FET to shut off as soon as any load current is detected. Shorting the ILIM pin to ground at any point during normal operation is detected as a fault and the part shuts down. The ILIM pin Short to GND fault detection circuit does not allow any load current higher than I_{CB} to flow through the device. This design provides robust eFuse behavior even under single point failure conditions. Refer to the [Fault Response](#) section for details on the device behavior after a fault.

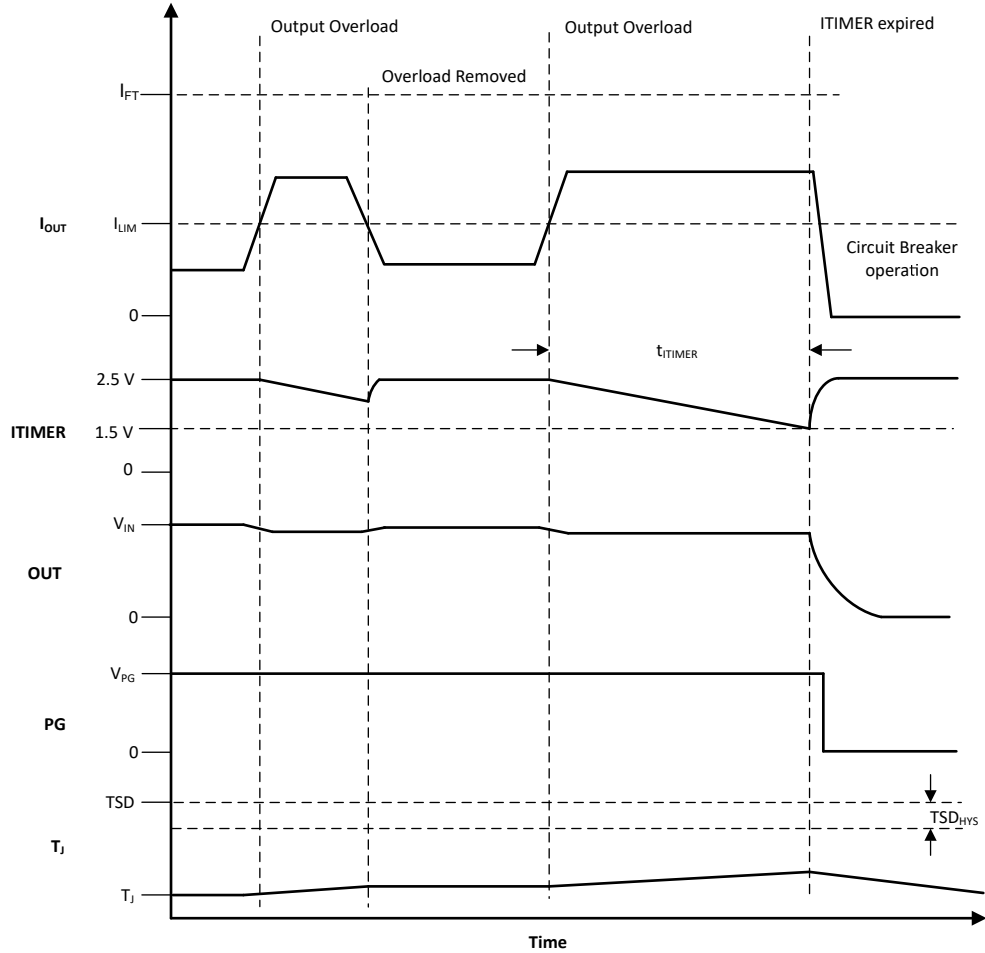

Figure 7-4. Circuit Breaker Response

The duration for which load transients are allowed can be adjusted using an appropriate capacitor value from ITIMER pin to ground. The transient overcurrent blanking interval can be calculated using [Equation 6](#).

$$t_{TIMER} \text{ (ms)} = \frac{C_{ITIMER} \text{ (nF)} \times \Delta V_{ITIMER} \text{ (V)}}{I_{ITIMER} \text{ (\mu A)}} \quad (6)$$

Leave the ITIMER pin open to allow the part to break the circuit with the minimum possible delay.

Table 7-1. Device ITIMER Functional Mode Summary

ITIMER Pin Connection	Timer Delay Before Overcurrent Response
OPEN	0 s
Capacitor to ground	As per Equation 6
Short to GND	ITIMER pin fault; part shuts off

Note

1. Shorting the ITIMER pin to ground is detected as a fault and the part shuts down. This provides robust eFuse behavior even in case of single point failure conditions. Refer to the [Fault Response](#) section for details on the device behavior after a fault.

2. Larger ITIMER capacitors take longer to charge during start-up and can lead to incorrect fault assertion if the ITIMER voltage is still below the pin short detection threshold after the device has reached steady state. To avoid this behavior, limit the maximum ITIMER capacitor to the value suggested by the following equation.

$$C_{\text{ITIMER}} < \frac{t_{\text{GHI}}}{53000}$$

$$t_{\text{GHI}} = t_{\text{D,ON}} + C_{\text{dVdt}} \times \left(\frac{V_{\text{IN}} + 3.6\text{V}}{I_{\text{dVdt}}} \right)$$

Where

- t_{GHI} is the time taken by the device to reach steady state
- $t_{\text{D,ON}}$ is the device turn-on delay
- C_{dVdt} is the dVdt capacitance
- I_{dVdt} is the dVdt charging current

It is possible to avoid incorrect ITIMER pin fault assertion and achieve higher ITIMER intervals if needed by increasing the dVdt capacitor value accordingly, but at the expense of higher start-up time.

Once the part shuts down due to a circuit-breaker fault, the part can be configured to either stay latched off or restart automatically. Refer to the [Fault Response](#) section for details.

7.3.3.3 Active Current Limiting

The TPS25983xL (Current Limiter) variants respond to output overcurrent conditions by actively regulating the current to a set limit after a user adjustable fault blanking interval. During steady-state operation, if the load current exceeds a user adjustable overcurrent threshold (I_{LIM}) set by the ILIM pin resistor (R_{ILIM}), but lower than the fast-trip threshold (I_{FT}), the device starts discharging the ITIMER pin capacitor using an internal pull-down current (I_{ITIMER}). If the load current drops below the overcurrent threshold before the ITIMER capacitor voltage drops by ΔV_{ITIMER} , the current limit action is not engaged and the ITIMER is reset by pulling it up to V_{INT} internally. This allows short transient overcurrent pulses to pass through the device without limiting the current. If the overcurrent condition persists, the ITIMER capacitor continues to discharge and once it falls by ΔV_{ITIMER} , the device regulates the FET gate voltage to actively limit the output current to the set I_{LIM} level. The device will exit current limiting when the load current falls below I_{LIM} . [Equation 7](#) can be used to calculate the R_{ILIM} value for a desired current limit.

$$R_{\text{ILIM}}(\Omega) = \frac{1460}{I_{\text{LIM}}(\text{A}) - 0.11} \quad (7)$$

Note

Leaving the ILIM pin Open sets the overcurrent threshold to zero and causes the FET to shut off as soon as any load current is detected. Shorting the ILIM pin to ground at any point during normal operation is detected as a fault and the part shuts down. The ILIM pin Short to GND fault detection circuit doesn't allow any load current higher than I_{CB} to flow through the device. This ensures robust eFuse behavior even under single point failure conditions. Refer to the [Fault Response](#) section for details on the device behavior after a fault.

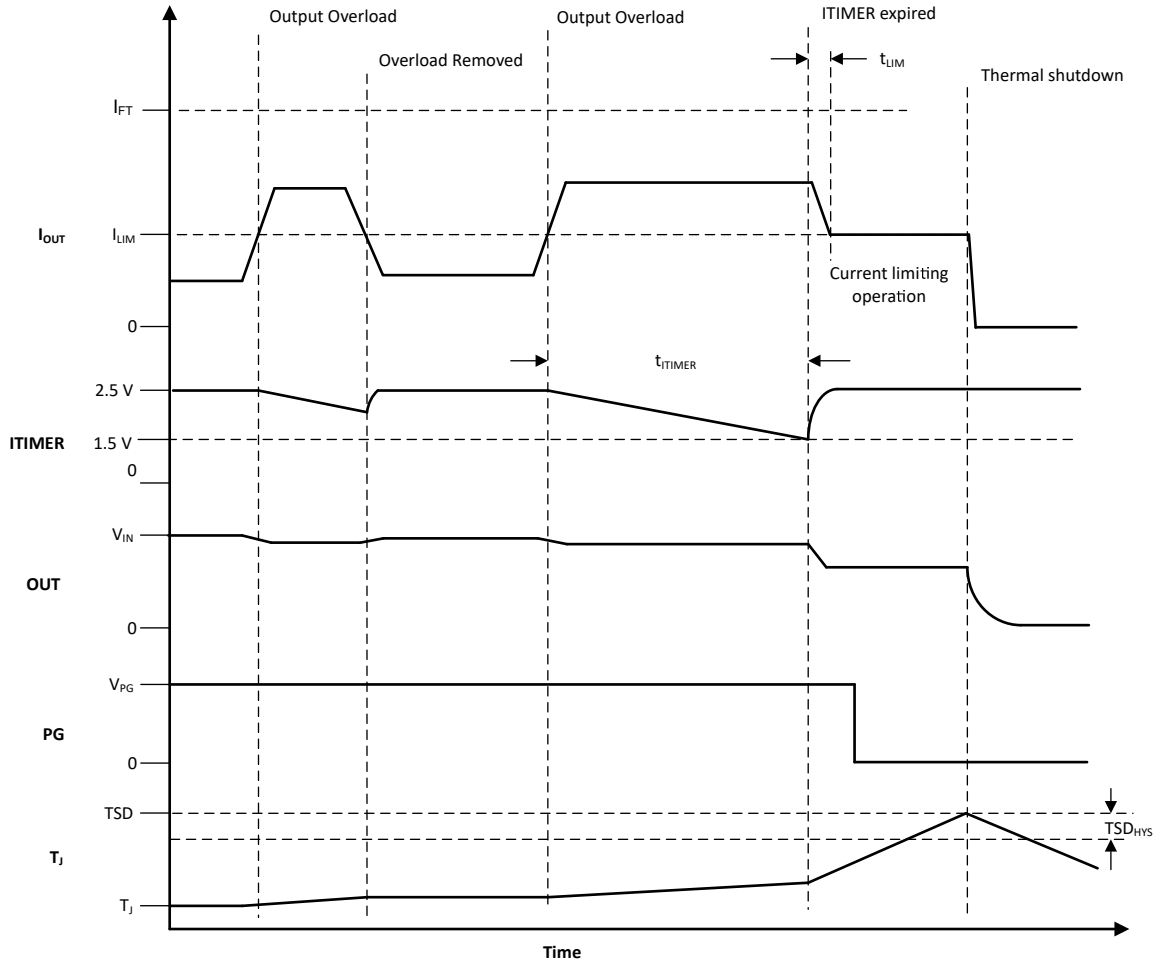

Figure 7-5. Active Current Limiter Response

The duration for which load transients are allowed can be adjusted using an appropriate capacitor value from ITIMER pin to ground. The transient overcurrent blanking interval can be calculated using [Equation 8](#).

$$t_{ITIMER} \text{ (ms)} = \frac{C_{ITIMER} \text{ (nF)} \times \Delta V_{ITIMER} \text{ (V)}}{I_{ITIMER} \text{ (\mu A)}} \quad (8)$$

Leave the ITIMER pin open to allow the part to activate the current limit with the minimum possible delay. Refer to [ITIMER Functional Mode Summary](#) for more details.

Note

1. Current limiting based on R_{ILIM} is active during startup for both Current Limit and Circuit Breaker variants. In case the startup current exceeds I_{LIM} , the device regulates the current to the set limit. However, during startup the current limit is engaged without waiting for the ITIMER delay.
2. The active current limit block employs a foldback mechanism during start-up based on the output voltage (V_{OUT}). When V_{OUT} is below the foldback threshold (V_{FB}), the current limit threshold is further lowered as compared to the steady-state setting.
3. Shorting the ITIMER pin to ground is detected as a fault and the part shuts down. This ensures robust eFuse behavior even in case of single point failure conditions. Refer to the [Fault Response](#) section for details on the device behavior after a fault.
4. Larger ITIMER capacitors take longer to charge during start-up and may lead to incorrect fault assertion if the ITIMER voltage is still below the pin short detection threshold after the device has reached steady state. To avoid this, it is recommended to limit the maximum ITIMER capacitor to the value suggested by the equation below.

$$C_{ITIMER} < \frac{t_{GHI}}{53000}$$

$$t_{GHI} = t_{D,ON} + C_{dvdt} \times \left(\frac{V_{IN} + 3.6V}{I_{dvdt}} \right)$$

Where

- t_{GHI} is the time taken by the device to reach steady state
- $t_{D,ON}$ is the device turn-on delay
- C_{dvdt} is the dVdt capacitance
- I_{dvdt} is the dVdt charging current

It is possible to avoid incorrect ITIMER pin fault assertion and achieve higher ITIMER intervals if needed by increasing the dVdt capacitor value accordingly, but at the expense of higher start-up time.

During current regulation, the output voltage will drop resulting in increased device power dissipation across the FET. If the device internal temperature (T_J) exceeds the thermal shutdown threshold (TSD), the FET is turned off. See [Overtemperature Protection \(OTP\)](#) for more details on device response to overtemperature.

7.3.3.4 Short-Circuit Protection

During an output short-circuit event, the current through the device increases very rapidly. When an output short-circuit is detected, the internal fast-trip comparator turns off the output within t_{SC} . During steady-state operation, the comparator employs a fixed threshold which is equal to I_{FT} . During inrush or current limit, the comparator employs a scalable threshold which is equal to $2 \times I_{LIM}$. After a fast-trip event, the device restarts in a current limited mode to try and restore power to the load quickly in case the fast trip was triggered by a transient event. However, if the fault is persistent, the device will stay in current limit causing the junction temperature to rise and eventually enter thermal shutdown. See [Overtemperature Protection \(OTP\)](#) section for details on the device response to overtemperature.

In some of the systems, for example servers or telecom equipment which house multiple hot-pluggable cards connected to a common supply backplane, there can be transients on the supply due to switching of large currents through the inductive backplane. This can result in current spikes on adjacent cards which could be potentially large enough to inadvertently trigger the fast-trip comparator of the eFuse. The TPS25983 avoids nuisance tripping in such cases thereby facilitating un-interrupted system operation.

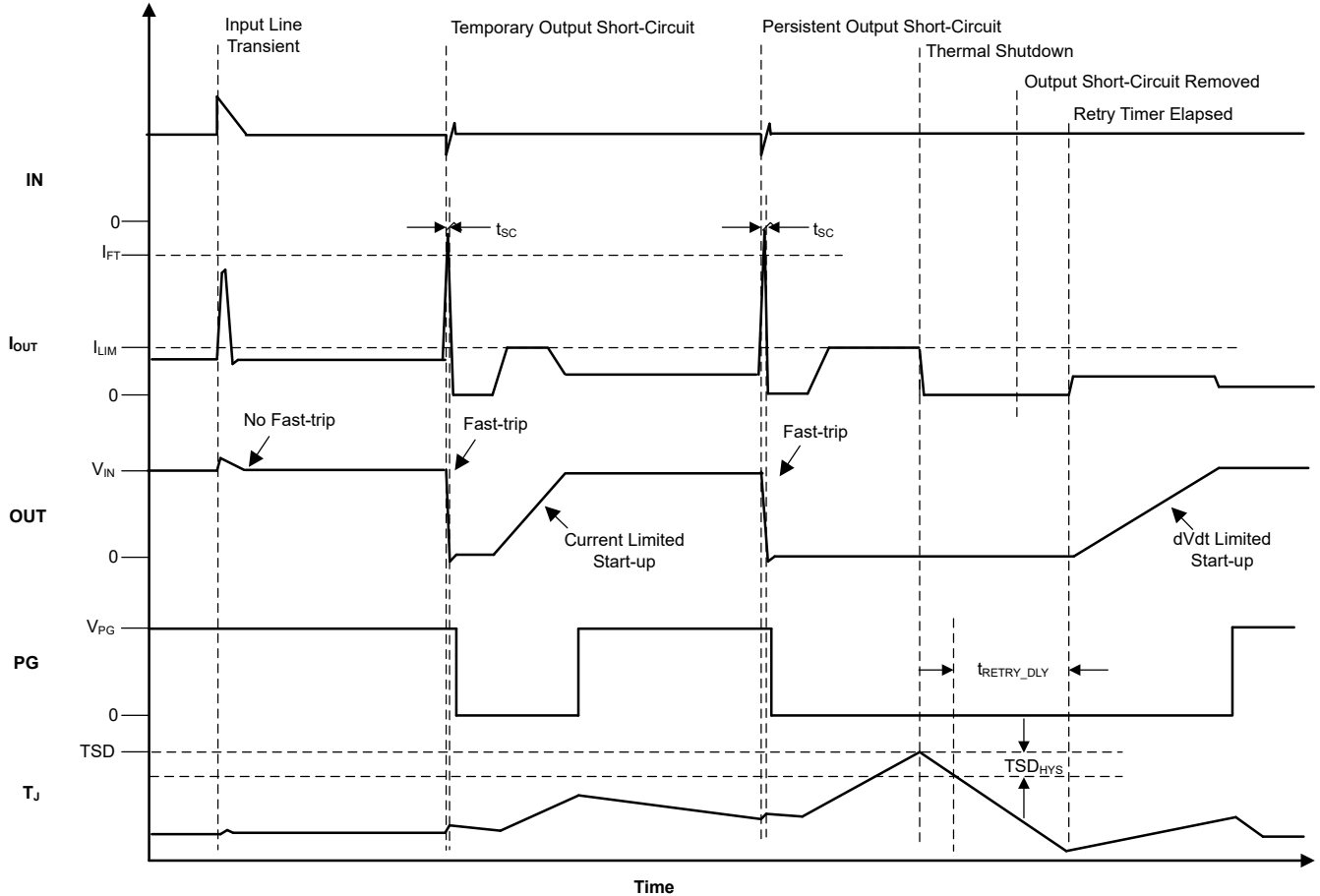

Figure 7-6. Input Line Transient and Output Short-Circuit Response

7.3.4 Overtemperature Protection (OTP)

The device monitors the internal die temperature (T_J) at all times and shuts down the part as soon as the temperature exceeds a safe operating level (TSD) thereby protecting the device from damage. The device will not turn back on until the die cools down sufficiently, that is the die temperature falls below ($TSD - TSD_{HYS}$). Thereafter, the part can be configured to either remain latched off or restart automatically. Refer to the [Fault Response](#) section for details.

7.3.5 Analog Load Current Monitor (IMON)

The device allows the system to monitor the output load current accurately by providing an analog current on the IMON pin which is proportional to the current through the FET. The user can connect a resistor from IMON to ground to convert this signal to a voltage which can be fed to the input of an Analog-to-Digital Converter. The internal amplifier on the IMON employs chopper based offset cancellation techniques to provide accurate measurement even at lower currents over time and temperature.

$$I_{LOAD} (A) = \frac{V_{IMON} (\mu V)}{R_{IMON} (\Omega) \times G_{IMON} (\mu A/A)} \quad (9)$$

It is recommended to limit the maximum IMON voltage to the values mentioned in [V_{IMON}\(Max\) Recommended Values](#). This is to ensure the IMON pin internal amplifier has sufficient headroom to operate linearly.

Table 7-2. V_{IMON}(MAX) Recommended Values

V _{IN}	Recommended V _{IMON} (MAX)
2.7 V	1 V
3.3 V	1.8 V

Table 7-2. $V_{IMON(MAX)}$ Recommended Values (continued)

V_{IN}	Recommended $V_{IMON(MAX)}$
> 5 V	3.3 V

It is recommended to add a RC low pass filter on the IMON output to filter out any glitches and get a smooth average current measurement. TI recommends a series resistance of 10 kΩ or higher.

7.3.6 Power Good (PG)

PG is an active high open drain output which indicates whether the FET is fully turned ON and the output voltage has reached the maximum value. After power-up, PG is pulled low initially. The gate driver circuit starts charging the gate capacitance from the internal charge pump. When the FET gate voltage reaches ($V_{IN} + 3.6$ V), PG is asserted after a de-glitch time (t_{PGD}). During normal operation, if at any time V_{OUT} falls below ($V_{IN} - V_{PGTHD}$), PG is de-asserted after a de-glitch time (t_{PGD}).

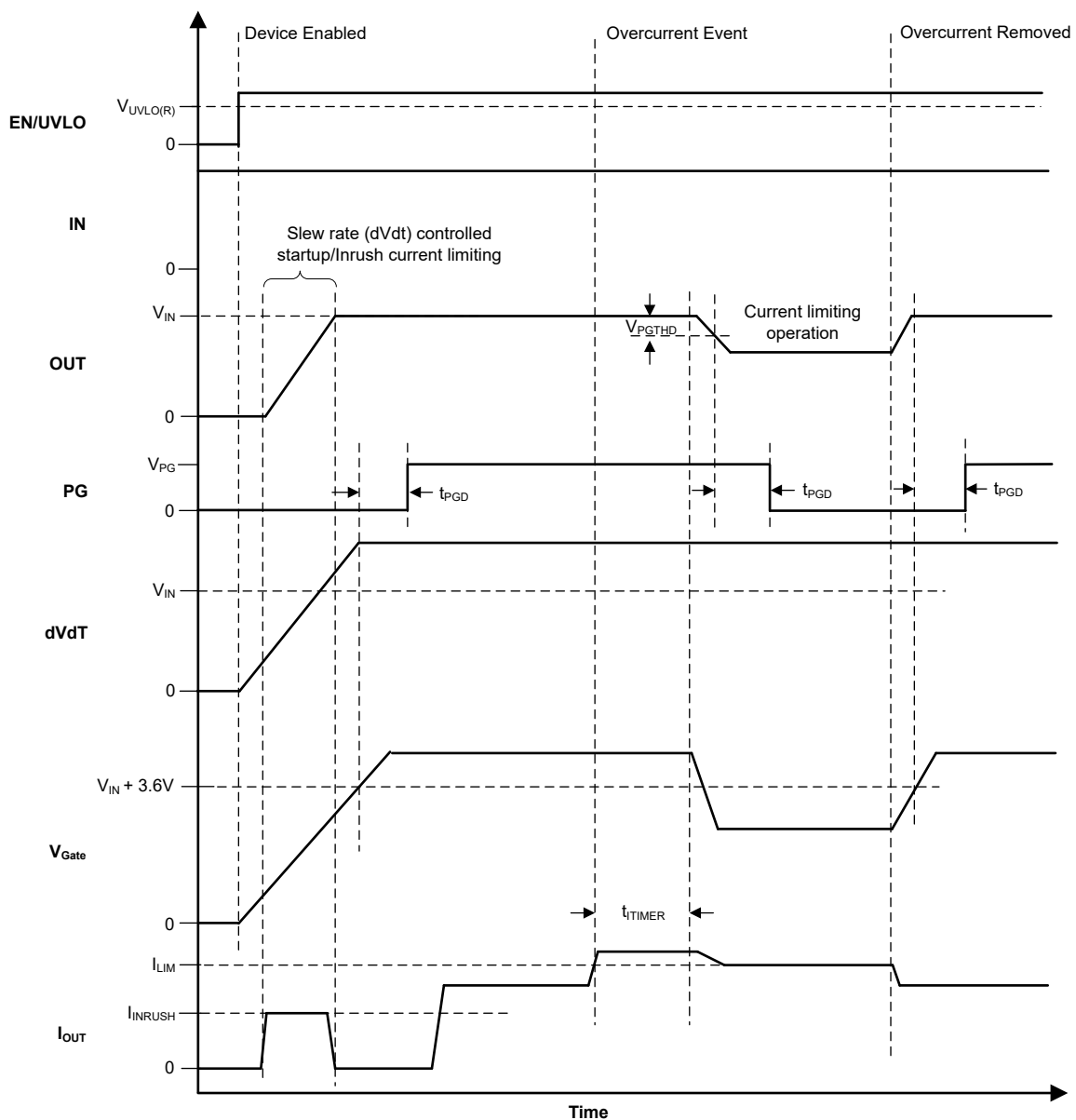

Figure 7-7. Power Good Assertion and De-assertion

Note

1. When there is no supply to the device, the PG pin is expected to stay low. However, there is no active pull-down in this condition to drive this pin all the way down to 0 V. If the PG pin is pulled up to an independent supply which is present even if the TPS25983 is unpowered, there can be a small voltage seen on this pin depending on the pin sink current, which in turn is a function of the pull-up supply voltage and resistor. Minimize the sink current to keep this pin voltage low enough not to be detected as a logic HIGH by associated external circuits in this condition.
2. The PG pin provides a mechanism to detect a possible failed MOSFET condition during start-up. If the PG does not get asserted for an extended period of time after the device is powered up and enabled, this behavior can be an indication of internal MOSFET failure.

7.3.7 Reverse Current Blocking FET Driver

TPS25983 provides an option to drive an external N-FET for implementing reverse current blocking function. The N-FET is connected in series with the eFuse in a common source configuration as shown in Figure 7-8. The gate of the blocking FET is controlled by the dVdt/BGATE pin of the eFuse. When the eFuse is turned ON and operating in steady-state, the dVdt/BGATE is driven high which turns the external FET fully ON to provide a low-impedance power path from input to output. When the eFuse turns OFF under any condition, the dVdt/BGATE pin is pulled low and the blocking FET is turned OFF. This behavior makes sure that there is no current path from the output to input in the OFF state.

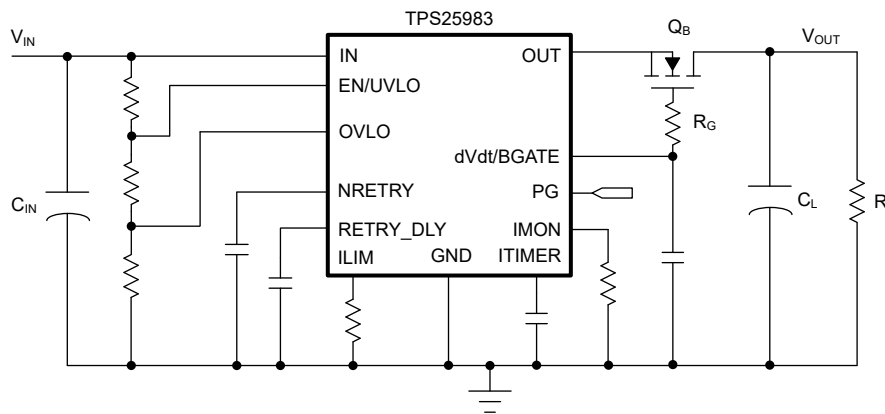

Figure 7-8. Reverse Current Blocking Using External FET

Figure 7-9 shows an example of TPS25983 reverse current blocking response. When the input supply is disconnected, there is some reverse current flow as the input supply start falling and the output capacitance also discharges initially. Once the input supply voltage falls low enough to trigger the undervoltage response, the device turns OFF the external FET to block the reverse current completely.

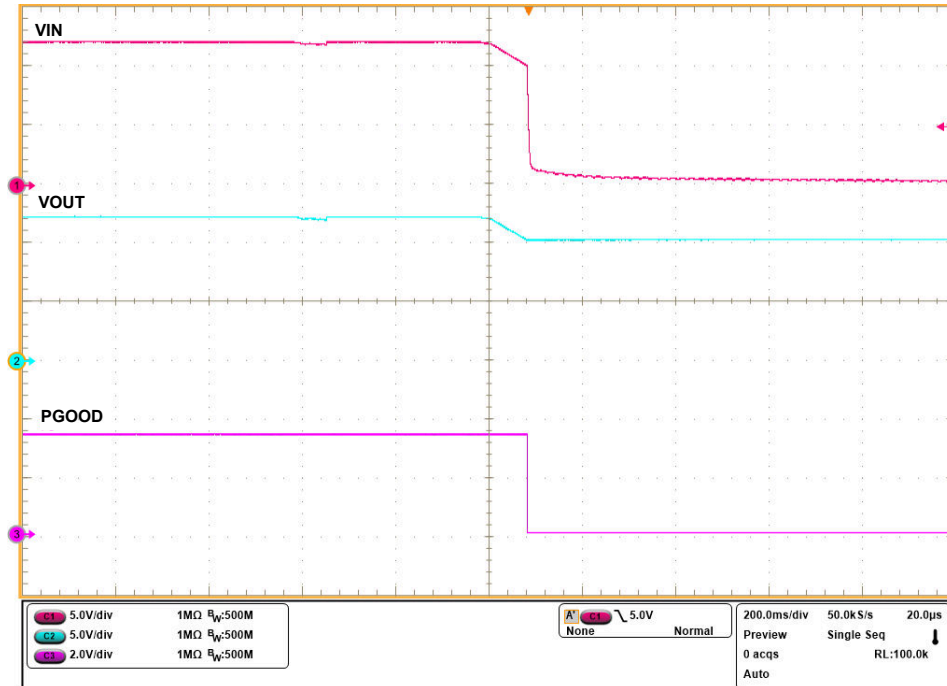

Figure 7-9. Reverse Current Blocking Response

7.3.8 Fault Response

The following events trigger an internal fault which causes the device to shut down:

- Overtemperature protection
- Circuit-breaker operation
- ITIMER pin short to GND
- ILIM pin short to GND

Once the device shuts down due to a fault, even if the associated external fault is subsequently cleared, the fault stays latched internally and the output cannot turn on again until the latch is reset. The fault latch can be externally reset by one of the following methods:

- Input supply voltage is driven low ($< V_{UV(F)}$)
- EN/UVLO voltage is driven low ($< V_{SD}$)

The fault latch can also be reset by an internal auto-retry logic. The user can either disable the auto-retry behavior completely (latch-off behavior) or configure the device to auto-retry indefinitely or for a limited number of times before latching off. The auto-retry behavior is controlled by the connections on the RETRY_DLY and NRETRY pins.

Table 7-3. Pin Configurable Fault Response

EN/UVLO	RETRY_DLY	NRETRY	DEVICE STATE
L	X	X	Disabled
H	Short to GND	X	No auto-retry (Latch-off)
H	Open	Open	Auto-retry 4 times with minimum delay between retries and then latch-off
H	Open	Short to GND	Auto-retry indefinitely with minimum delay between retries
H	Capacitor to GND	Capacitor to GND	Auto-retry delay and count as per Equation 10 and Equation 11
H	Capacitor to GND	Open	Auto-retry 4 times with finite delay between retries as per Equation 10 and then latch-off

Table 7-3. Pin Configurable Fault Response (continued)

EN/UVLO	RETRY_DLY	NRETRY	DEVICE STATE
H	Capacitor to GND	Short to GND	Auto-retry indefinitely with finite delay between retries as per Equation 10

To configure the part for a finite number of auto-retries with a finite auto-retry delay, first choose the capacitor value on RETRY_DLY pin using the following equation.

$$t_{\text{RETRY_DLY}} (\mu\text{s}) = \frac{128 \times (C_{\text{RETRY_DLY}} (\text{pF}) + 4 \text{ pF}) \times V_{\text{RETRY_DLY_HYS}} (V)}{I_{\text{RETRY_DLY}} (\mu\text{A})} \quad (10)$$

Next, choose the capacitor value on the NRETRY pin using the following equation.

$$N_{\text{RETRY}} = \frac{4 \times I_{\text{RETRY_DLY}} (\mu\text{A}) \times C_{\text{NRETRY}} (\text{pF})}{I_{\text{NRETRY}} (\mu\text{A}) \times (C_{\text{RETRY_DLY}} (\text{pF}) + 4 \text{ pF})} \quad (11)$$

The number of auto-retries is quantized to certain discrete levels as shown in [Table 7-4](#).

Table 7-4. NRETRY Quantization Levels

NRETRY Calculated From Equation 11	NRETRY Actual
0 < N < 4	4
4 < N < 16	16
16 < N < 64	64
64 < N < 256	256
256 < N < 1024	1024

Table 7-5. NRETRY and RETRY_DLY Combination Examples

Auto Retry Delay	915 ms	416 ms	91.7 ms	9.3 ms	3 ms
RETRY_DLY Capacitor	22 nF	10 nF	2.2 nF	220 pF	68 pF
No. of Auto Retries	NRETRY Capacitor				
4	Open				
16	47 nF	22 nF	4.7 nF	1 nF	220 pF
64	0.22 μF	0.1 μF	22 nF	2.2 nF	1 nF
256	1 μF	0.47 μF	0.1 μF	10 nF	4.7 nF
1024	3.3 μF	1.5 μF	0.47 μF	33 nF	10 nF
Infinite	Short to GND				

A spreadsheet design tool [TPS25983xx Design Calculator](#) is also available for simplified calculations.

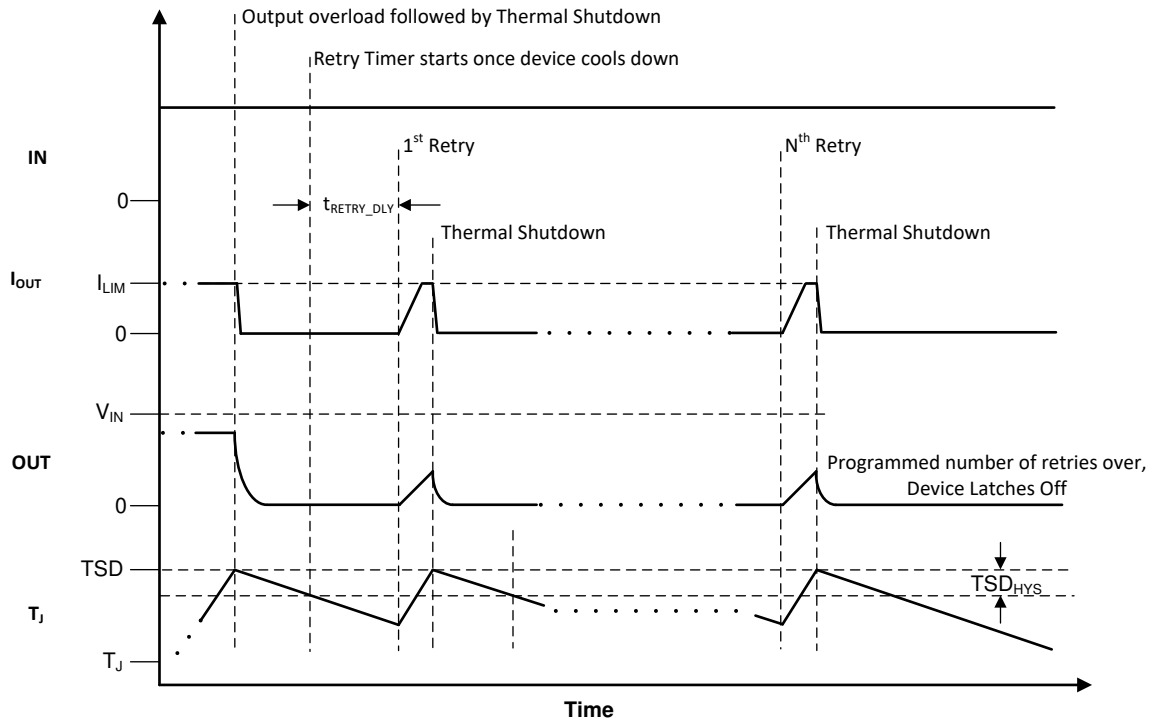

Figure 7-10. Auto-Retry After Fault

The auto-retry logic has a mechanism to reset the count to zero if two consecutive faults occur far apart in time. This mechanism makes sure that the auto-retry response to any later fault is handled as a fresh sequence and not as a continuation of the previous fault. If the fault which triggered the shutdown and subsequent auto-retry cycle is cleared eventually and does not occur again for a duration equal to 7 retry delay timer periods starting from the last fault, the auto-retry logic resets the internal auto-retry count to zero.

7.4 Device Functional Modes

The TPS25983 can be pin strapped to support various configurable functional modes.

Table 7-6. Fault Response Functional Modes

EN/UVLO	RETRY_DLY	NRETRY	DEVICE STATE
L	X	X	Disabled
H	Short to GND	X	No auto-retry (Latch-off)
H	Open	Open	Auto-retry 4 times with minimum delay between retries and then latch-off
H	Open	Short to GND	Auto-retry indefinitely with minimum delay between retries
H	Capacitor to GND	Capacitor to GND	Auto-retry delay and count as per Equation 10 and Equation 11
H	Capacitor to GND	Open	Auto-retry 4 times with finite delay between retries as per Equation 10 and then latch-off
H	Capacitor to GND	Short to GND	Auto-retry indefinitely with finite delay between retries as per Equation 10

Refer to [Fault Response](#) section for more details.

8 Application and Implementation

Note

Information in the following applications sections is not part of the TI component specification, and TI does not warrant its accuracy or completeness. TI's customers are responsible for determining suitability of components for their purposes, as well as validating and testing their design implementation to confirm system functionality.

8.1 Application Information

The TPS25983 device is an integrated 20-A eFuse that is typically used for hot-swap and power rail protection applications. The device operates from 2.7 V to 26 V with adjustable overcurrent and undervoltage protection. This device also provides configurable overvoltage protection. The device aids in controlling the inrush current and has the flexibility to configure the number of auto-retries and retry delay. The adjustable overcurrent blanking timer provides the functionality to allow transient overcurrent pulses without limiting or tripping. These devices protect source, load and internal MOSFET from potentially damaging events in systems such as server standby rails, PCIe cards, SSDs, HDDs, optical modules, routers and switches.

The following design procedure can be used to select the supporting component values based on the application requirement. Additionally, a spreadsheet design tool [TPS25983xx Design Calculator](#) is available in the web product folder.

8.2 Typical Application: Standby Power Rail Protection in Datacenter Servers

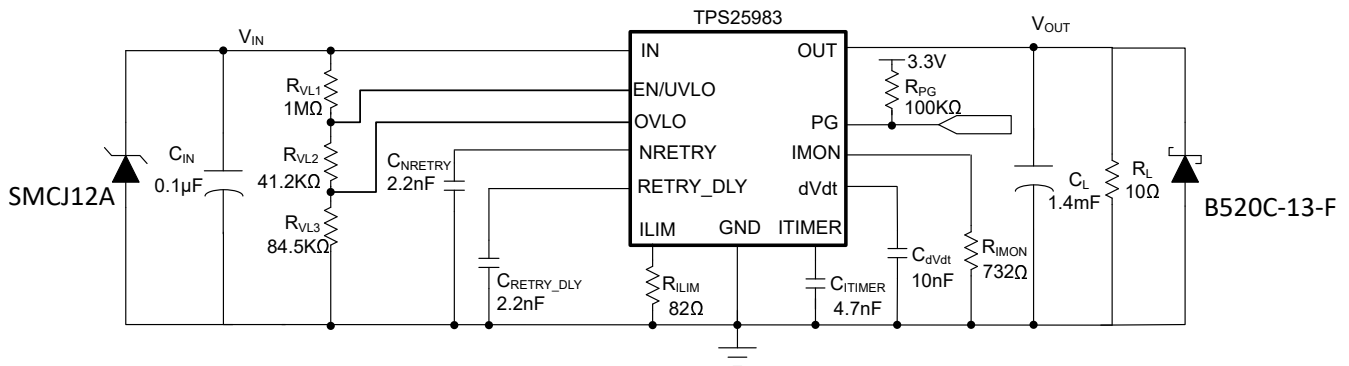

Figure 8-1. Typical Application Schematic - Protection for Server Standby Rail

8.2.1 Design Requirements

Table 8-1 shows the design parameters for this application example.

Table 8-1. Design Parameters

DESIGN PARAMETER	EXAMPLE VALUE
Input voltage, V_{IN}	12 V
Undervoltage lockout set point, $V_{IN_{UVLO}}$	10.8 V
Overvoltage lockout set point, $V_{IN_{OVLO}}$	16 V
Maximum load current, I_{OUT}	15 A
Current limit, I_{LIM}	18 A
Transient overcurrent blanking interval (t_{TIMER})	2 ms
Load capacitance, C_{OUT}	1.4 mF
Load at start-up, $R_{L(SU)}$	10 Ω
Output voltage ramp time, T_{dVdt}	20 ms
Maximum ambient temperature, T_A	70°C
Retry delay, t_{RETRY_DLY}	100 ms

Table 8-1. Design Parameters (continued)

DESIGN PARAMETER	EXAMPLE VALUE
No. of retries, N _{RETRY}	4

8.2.2 Detailed Design Procedure

8.2.2.1 Device Selection

This design example considers a 12-V system operating voltage with a tolerance of $\pm 10\%$. The rated load current is 15 A. If the current exceeds 18 A, then the device must allow overload current for 2-ms interval before breaking the circuit and then restart. Accordingly, the TPS2598300 variant is chosen. Refer to [Device Comparison Table](#) for device options. Ambient temperatures may range from 20°C to 70°C. The load has a minimum input capacitance of 1.4 mF and start-up resistive load of 10 Ω . The downstream load is turned on only after the PG signal is asserted.

8.2.2.2 Setting the Current Limit Threshold: R_{ILIM} Selection

The R_{ILIM} resistor at the ILIM pin sets the overload current limit, whose value can be calculated using [Equation 12](#).

$$R_{ILIM}(\Omega) = \frac{1460}{I_{LIM}(A) - 0.11} \quad (12)$$

For $I_{LIM} = 18$ A, R_{ILIM} value is calculated to be 81.6 Ω . Choose the closest available standard value: 82 Ω , 1%.

8.2.2.3 Setting the Undervoltage and Overvoltage Lockout Set Point

The supply undervoltage and overvoltage thresholds are set using the resistors R1, R2, and R3, whose values can be calculated using [Equation 13](#) and [Equation 14](#).

$$V_{IN(UV)} = \frac{V_{UVLO(R)} \times (R1 + R2 + R3)}{R2 + R3} \quad (13)$$

$$V_{IN(OV)} = \frac{V_{OV(R)} \times (R1 + R2 + R3)}{R3} \quad (14)$$

Where $V_{UVLO(R)}$ is the UVLO rising threshold and $V_{OV(R)}$ is the OVLO rising threshold. Because R1, R2, and R3 leak the current from input supply V_{IN} , these resistors must be selected based on the acceptable leakage current from input power supply V_{IN} . The current drawn by R1, R2, and R3 from the power supply is $I_{R123} = V_{IN} / (R1 + R2 + R3)$. However, leakage currents due to external active components connected to the resistor string can add error to these calculations. So, the resistor string current, I_{R123} must be chosen to be 20 times greater than the leakage current expected on the EN/UVLO and OVLO pins.

From the device electrical specifications, both the EN/UVLO and OVLO leakage currents are 0.1 μ A (maximum), $V_{OV(R)} = 1.2$ V and $V_{UVLO(R)} = 1.2$ V. From design requirements, $V_{IN(OV)} = 16$ V and $V_{IN(UV)} = 10.8$ V. To solve the equation, first choose the value of R1 = 1 M Ω and use the above equations to solve for R2 = 40.6 k Ω and R3 = 84.4 k Ω .

Using the closest standard 1% resistor values, we get R1 = 1 M Ω , R2 = 41.2 k Ω , and R3 = 84.5 k Ω .

8.2.2.4 Choosing the Current Monitoring Resistor: R_{IMON}

Voltage at IMON pin V_{IMON} is proportional to the output load current. This can be connected to an ADC of the downstream system for monitoring the operating condition and health of the system. The R_{IMON} must be selected based on the maximum load current and the maximum IMON pin voltage at full-scale load current. The maximum IMON pin voltage must be selected based on the input voltage range of the ADC used or the value suggested in [VIMON\(Max\) Recommended Values](#), whichever is lower. R_{IMON} is set using [Equation 15](#).

$$R_{IMON}(\Omega) = \frac{V_{IMONmax}(V)}{I_{OUTmax}(A) \times 243 \times 10^{-6}} \quad (15)$$

For $I_{LIM} = 18$ A and considering the operating range of ADC to be 0 V to 3.3 V, R_{IMON} can be calculated as,

$$R_{IMON} (\Omega) = \frac{3.3}{18 \times 243 \times 10^{-6}} = 745 \Omega \quad (16)$$

Selecting R_{IMON} value less than shown in [Equation 16](#) ensures that ADC limits are not exceeded for maximum value of load current. Choose closest available standard value: 732 Ω , 1%.

8.2.2.5 Setting the Output Voltage Ramp Time (T_{dVdt})

For a successful design, the junction temperature of device must be kept below the absolute maximum rating during both dynamic (start-up) and steady state conditions. Dynamic power stresses often are an order of magnitude greater than the static stresses, so it is important to determine the right start-up time and in-rush current limit required with system capacitance to avoid thermal shutdown during start-up with and without load.

The required ramp-up capacitor C_{dVdt} is calculated considering the two possible cases (see [Case 1: Start-Up Without Load: Only Output Capacitance \$C_{OUT}\$ Draws Current](#) and [Case 2: Start-Up With Load: Output Capacitance \$C_{OUT}\$ and Load Draw Current](#)).

8.2.2.5.1 Case 1: Start-Up Without Load: Only Output Capacitance C_{OUT} Draws Current

During start-up, as the output capacitor charges, the voltage drop as well as the power dissipated across the internal FET decreases. The average power dissipated in the device during start-up is calculated using [Equation 17](#).

$$P_{D(INRUSH)} = 0.5 \times V_{IN} \times I_{INRUSH} \quad (17)$$

Where I_{INRUSH} is the inrush current and is determined by [Equation 18](#).

$$I_{INRUSH} = C_{OUT} \times \frac{V_{IN}}{T_{dVdt}} \quad (18)$$

[Equation 17](#) assumes that the load does not draw any current (apart from the capacitor charging current) until the output voltage has reached its final value.

8.2.2.5.2 Case 2: Start-Up With Load: Output Capacitance C_{OUT} and Load Draw Current

When the load draws current during the turn-on sequence, there is additional power dissipated. Considering a resistive load during start-up $R_{L(SU)}$, load current ramps up proportionally with increase in output voltage during T_{dVdt} time. [Equation 19](#) shows the average power dissipation in the internal FET during charging time due to resistive load.

$$P_{D(LOAD)} = \left(\frac{1}{6}\right) \times \frac{V_{IN}^2}{R_{L(SU)}} \quad (19)$$

[Equation 20](#) gives the total power dissipated in the device during start-up.

$$P_{D(STARTUP)} = P_{D(INRUSH)} + P_{D(LOAD)} \quad (20)$$

The power dissipation, with and without load, for selected start-up time must not exceed the start-up thermal shutdown limits as shown in [Thermal Shutdown Plot During Start-up](#).

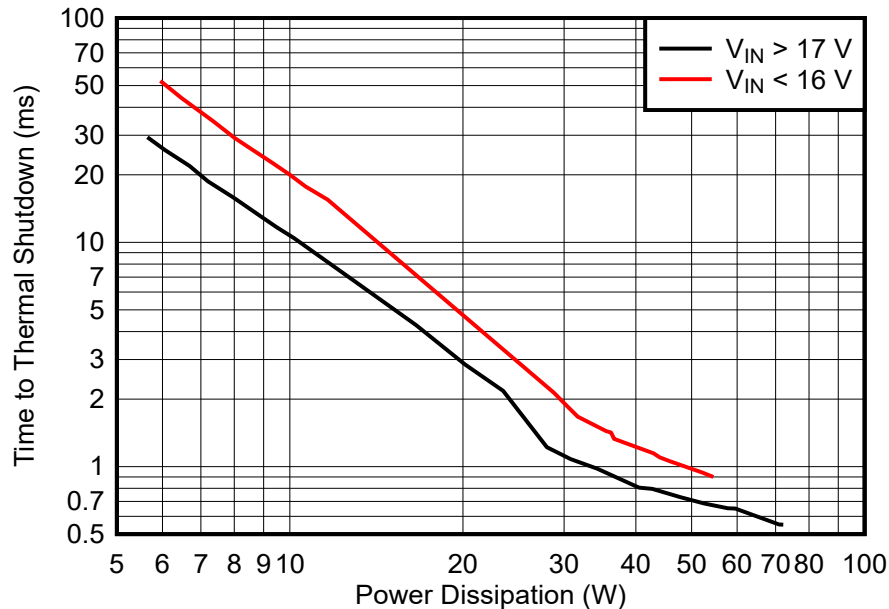

Figure 8-2. Thermal Shutdown Plot During Start-up

For the design example under discussion, the output voltage has to be ramped up in 20 ms, which mandates a slew-rate of 0.6 V/ms for a 12-V rail.

The required C_{dVdt} capacitance on dVdt pin to set 0.6-V/ms slew rate can be calculated using [Equation 21](#).

$$C_{dVdt}(\text{pF}) = \frac{4600}{\text{SR}(\text{V/ms})} = 7666 \text{ pF} \quad (21)$$

The dVdt capacitor is subjected to typically $V_{IN} + 4\text{ V}$ during startup. The high voltage bias leads to a drop in the effective capacitor value. So, it is suggested to choose 20% higher than the calculated value, which gives 9.2 nF. Choose closest 10% standard value: 10 nF

The 10 nF C_{dVdt} capacitance sets a slew-rate of 0.46 V/ms and output ramp time T_{dVdt} of 26 ms.

The inrush current drawn by the load capacitance C_{OUT} during ramp-up can be calculated using [Equation 22](#).

$$I_{INRUSH} = 1.4 \text{ mF} \times \frac{12 \text{ V}}{26 \text{ ms}} = 0.65 \text{ A} \quad (22)$$

The inrush power dissipation can be calculated using [Equation 23](#).

$$P_{D(INRUSH)} = 0.5 \times 12 \times 0.65 = 3.9 \text{ W} \quad (23)$$

For 3.9 W of power loss, the thermal shutdown time of the device must be greater than the ramp-up time T_{dVdt} to ensure a successful start-up. [Figure 8-2](#) shows the start-up thermal shutdown limit. For 3.9 W of power, the shutdown time is approximately 100 ms. So it is safe to use 26 ms as the start-up time without any load on the output.

The additional power dissipation when a 10- Ω load is present during start-up is calculated using [Equation 24](#).

$$P_{D(\text{LOAD})} = \left(\frac{1}{6}\right) \times \frac{12^2}{10} = 2.4\text{W} \quad (24)$$

The total device power dissipation during start-up can be calculated using [Equation 25](#).

$$P_{D(\text{STARTUP})} = 3.9 + 2.4 = 6.3\text{ W} \quad (25)$$

From [Thermal Shutdown Plot During Start-up](#), the thermal shutdown time for 6.3 W is approximately 40 ms. It is safe to have 30% margin to allow for variation of system parameters such as load, component tolerance, and input voltage. So it is well within acceptable limits to use the 10 nF for C_{dVdt} capacitor with start-up load of 10 Ω .

When C_{OUT} is large, there is a need to decrease the power dissipation during start-up. This can be done by increasing the value of the C_{dVdt} capacitor. A spreadsheet tool [TPS25983xx Design Calculator](#) available on the web can be used for iterative calculations.

8.2.2.6 Setting the Transient Overcurrent Blanking Interval (t_{ITIMER})

For the design example under discussion, overcurrent transients are allowed for 2-ms duration. This blanking interval can be set by selecting appropriate capacitor C_{ITIMER} from ITIMER pin to ground. The value of C_{ITIMER} to set 2 ms for t_{ITIMER} can be calculated using [Equation 26](#).

$$C_{ITIMER} (\text{nF}) = \frac{t_{ITIMER} (\text{ms})}{0.47} = 4.255\text{ nF} \quad (26)$$

Choose closest available standard value: 4.7 nF, 10%.

8.2.2.7 Setting the Auto-Retry Delay and Number of Retries

The time delay between retries can be programmed by selecting capacitor C_{RETRY_DLY} on RETRY_DLY pin. The value of C_{RETRY_DLY} to set a 100-ms auto-retry delay can be calculated using [Equation 27](#).

$$C_{RETRY_DLY} (\text{pF}) = \frac{t_{RETRY_DLY} (\mu\text{s})}{46.83} - 4\text{ pF} = 2131.38\text{ pF} \quad (27)$$

Choose closest available standard value: 2.2 nF, 10%.

The number of auto-retry attempts can be set by a capacitor C_{NRETRY} on the NRETRY pin using [Equation 28](#).

$$N_{RETRY} = \frac{4 \times C_{NRETRY} (\text{pF})}{C_{RETRY_DLY} (\text{pF}) + 4\text{ pF}} \quad (28)$$

For this design example, the requirement is to retry 4 times after the device shuts down due to a fault. Since, the number of auto-retries can be adjusted in discrete steps as explained in [Fault Response](#), choose C_{NRETRY} such that N_{RETRY} is less than 4. Use [Equation 29](#) to calculate C_{NRETRY} .

$$C_{NRETRY} (\text{pF}) < \frac{N_{RETRY} \times (C_{RETRY_DLY} (\text{pF}) + 4\text{ pF})}{4} < 2204\text{ pF} \quad (29)$$

Choose closest available standard value: 2.2 nF, 10%.

8.2.3 Application Curves

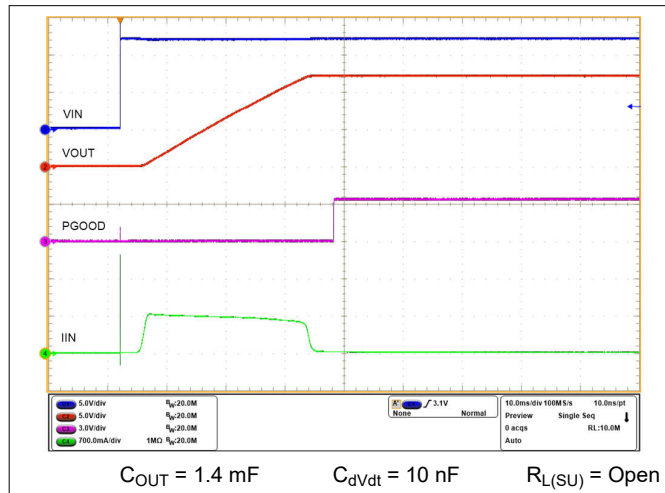

Figure 8-3. Hot-Plug Start-Up Without Load on Output, dVdt Limited

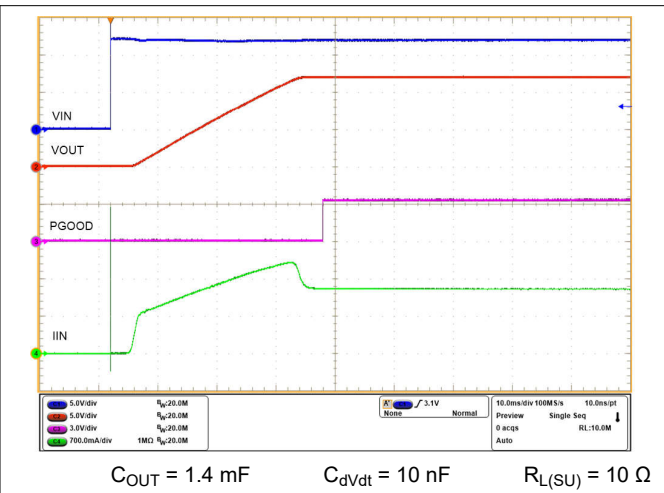

Figure 8-4. Hot-Plug Start-Up With Load on Output, dVdt Limited

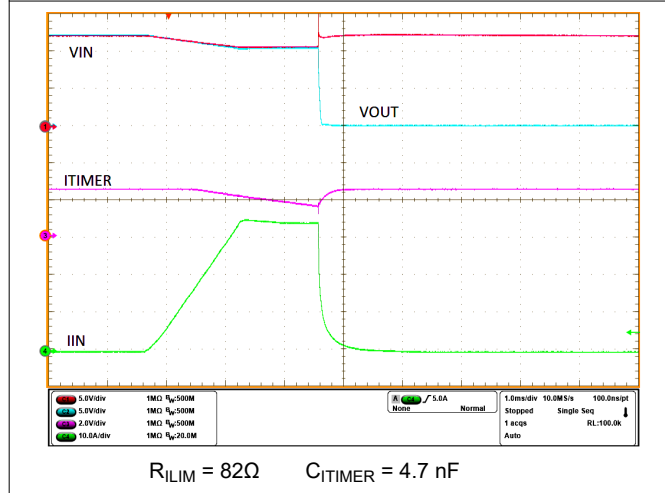

Figure 8-5. Circuit Breaker With Transient Overcurrent Blanking Interval of 2 ms

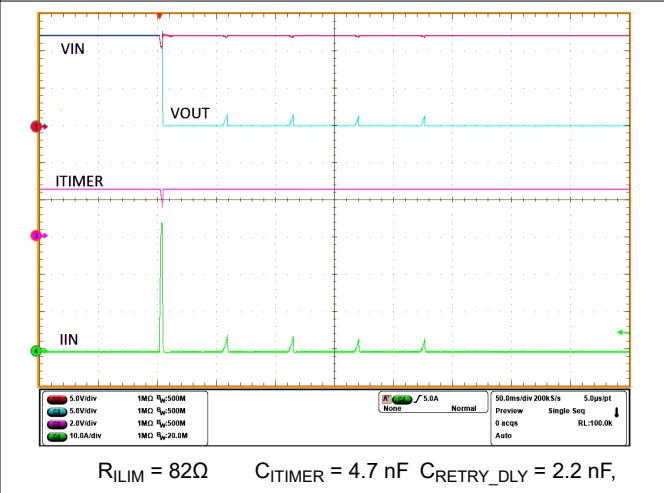
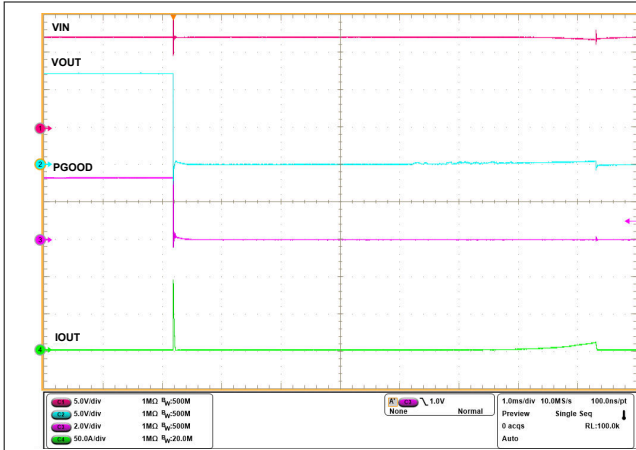
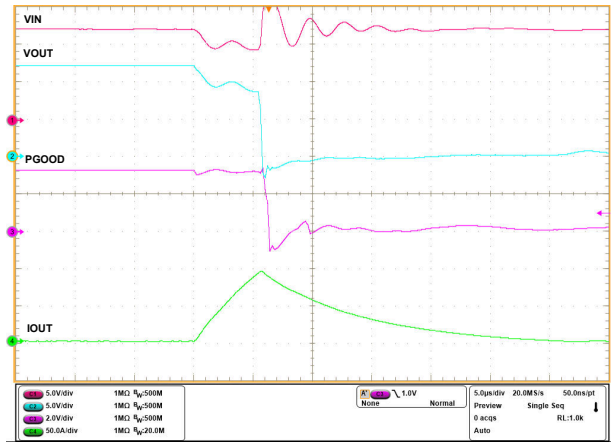

Figure 8-6. Circuit Breaker, Auto-Retry 4 Times With Retry Delay of 100 ms



$R_{LIM} = 82 \Omega$

Figure 8-7. Output Hard Short-Circuit While ON



$R_{LIM} = 82 \Omega$

Figure 8-8. Output Hard Short-Circuit While ON (Zoomed In)

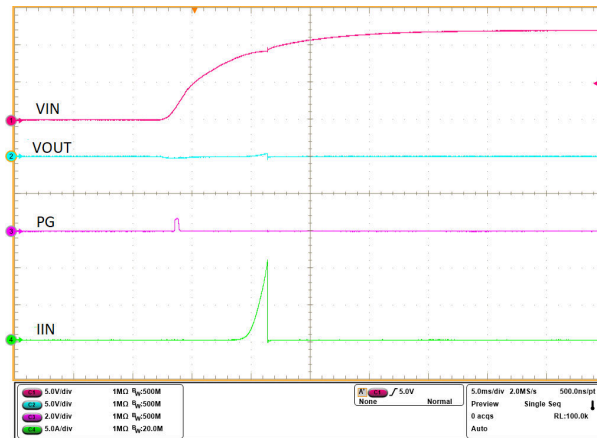

Figure 8-9. Power-Up With Short-Circuit on Output

8.3 System Examples

8.3.1 Optical Module Power Rail Path Protection

Optical modules are commonly used in high-bandwidth data communication systems such as optical networking equipment, enterprise or data-center switches, and routers. Several variants of optical modules are available in the market, which differ in the form-factor and the data speed support (Gbit/s). Of these, the popular variant double dense quad small form-factor pluggable (QSFP-DD) module supports speeds up to 400 Gbit/s. In addition to the system protection during hot-plug events, the other key requirement for optical module is the tight voltage regulation. The optical module uses 3.3-V supply and requires voltage regulation within $\pm 5\%$ for proper operation.

A typical power tree of such system is shown in Figure 8-10. The optical line card consists of DC-DC converter, protection device (eFuse) and power supply filters. The DC-DC converter steps-down the 12 V to 3.3 V and maintains the 3.3-V rail within $\pm 2\%$. The power supply filtering network uses 'LC' components to reduce high frequency noise injection into the optical module. The DC resistance of the inductor 'L' causes voltage drop of around 1.5% which leaves us with a voltage drop budget of just 1.5% ($3.3 \text{ V} \times 1.5\% = 50 \text{ mV}$) across the protection device. Considering a maximum load current of 5.5 A per module, the maximum ON-resistance of the protection device should be less than 9 m Ω . TPS25983 eFuse offers ultra-low ON-resistance of 2.7 m Ω (typical) and 4.5 m Ω (maximum, across temperature), thereby meeting the target specification with additional margin to spare and simplifying the overall system design.

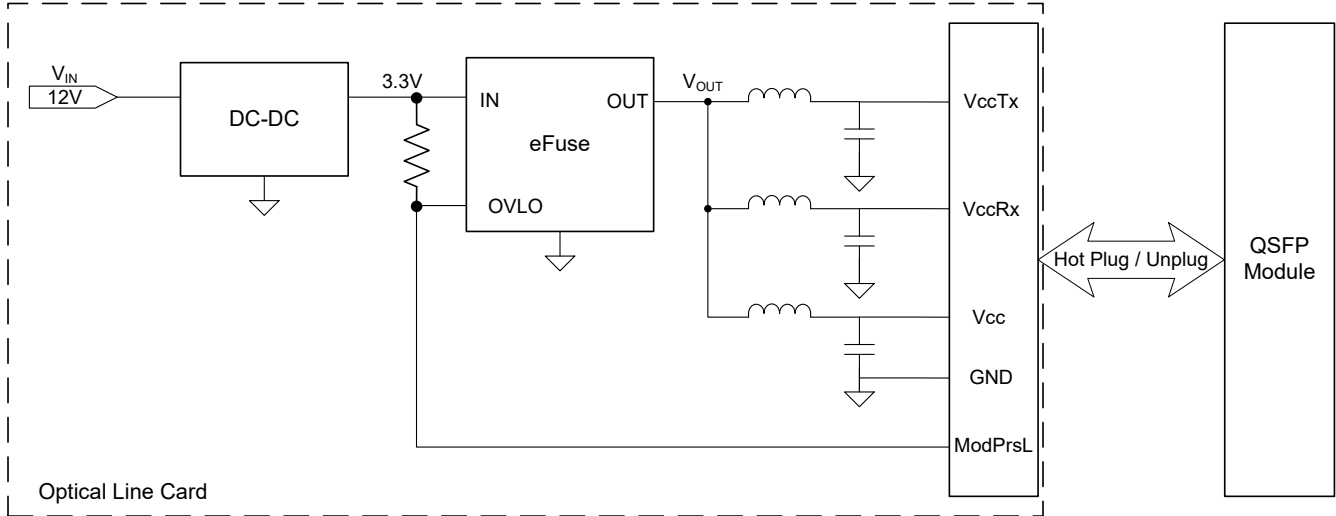

Figure 8-10. Power Tree Block Diagram of a Typical Optical Line Card

As shown in [Figure 8-10](#), ModPrsL signal acts as a handshake signal between the line card and the optical module. ModPrsL is always pulled to ground inside the module. When the module is hot-plugged into the host “Optical Line Card” connector, the ModPrsL signal pulls down the OVLO pin and enables the TPS25983 eFuse to power the module. This ensures that power is applied on the port only when a module is plugged in and disconnected when there is no module present.

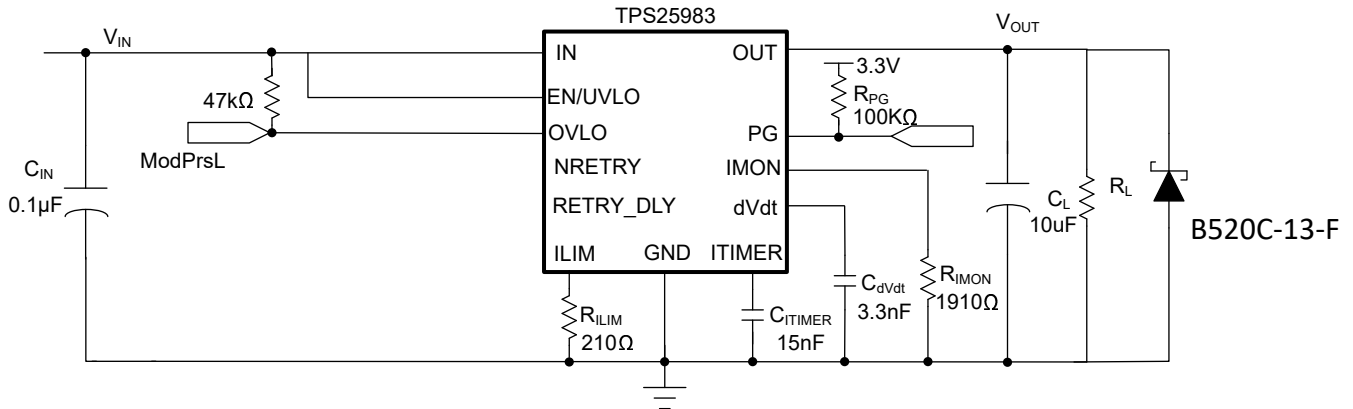

Figure 8-11. TPS2598300 Configured for a 3.3-V Power Rail Path Protection in Optical Module

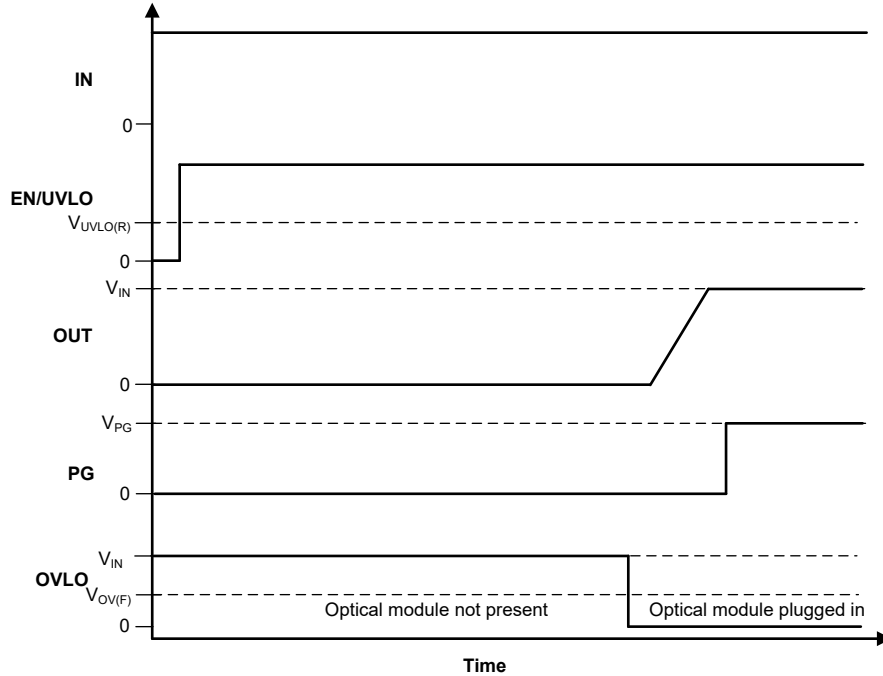

Figure 8-12. Optical Module Presence Detection Timing Diagram

8.3.1.1 Design Requirements

Table 8-2 shows the design parameters for this example.

Table 8-2. Design Parameters

DESIGN PARAMETER	EXAMPLE VALUE
Input voltage, V_{IN}	3.3 V
Overvoltage lockout, V_{OVP}	3.7 V
Maximum voltage drop in the path	±5%
Maximum load current, I_{OUT}	5.5 A
Current limit, I_{LIM}	7 A
Transient overcurrent blanking interval (t_{TIMER})	6 ms
Load capacitance, C_{OUT}	10 μ F
Maximum ambient temperature, T_A	85°C
Module present detection, ModPrsL	Yes
Retry delay, t_{RETRY_DLY}	200 μ s
No. of retries, N_{RETRY}	4

8.3.1.2 Device Selection

Optical modules are very sensitive to supply voltage variations and thus require input overvoltage protection. TPS2598300 variant from TPS25983 family is selected to set overvoltage protection at 3.7 V. TPS2598300 allows overcurrents for a user specified blanking interval t_{TIMER} before breaking the circuit path. In this use case, t_{TIMER} is set for 6 ms interval.

8.3.1.3 External Component Settings

By following similar design procedure as outlined in [Section 8.2.2](#), the external component values are calculated as below

- $R_{ILIM} = 210 \Omega$ to set 7-A current limit
- $C_{TIMER} = 15 \text{ nF}$ to set fault blanking time of 6 ms
- $R_{IMON} = 1910 \Omega$ to set maximum IMON pin voltage V_{IMON} within ADC range of 3.3 V
- C_{dVdt} capacitance is chosen as 3.3 nF
- Leave RETRY_DLY and NRETRY pins OPEN to set minimum auto-retry delay of 200 μs and number of retries to 4

8.3.1.4 Voltage Drop

[Table 8-3](#) shows the power path voltage drop (%) due to the eFuse in QSFP modules of different power classes.

Table 8-3. Voltage Drop Across TPS25983 on QSFP Module Power Rail

POWER CLASS	MAXIMUM POWER CONSUMPTION PER MODULE (W)	MAXIMUM LOAD CURRENT (A)	TYPICAL VOLTAGE DROP (%)
1	1.5	0.454	0.037
2	3.5	1.06	0.087
3	7	2.12	0.174
4	8	2.42	0.2
5	10	3.03	0.248
6	12	3.63	0.3
7	14	4.24	0.347
8	18	5.45	0.446

8.3.1.5 Application Curves

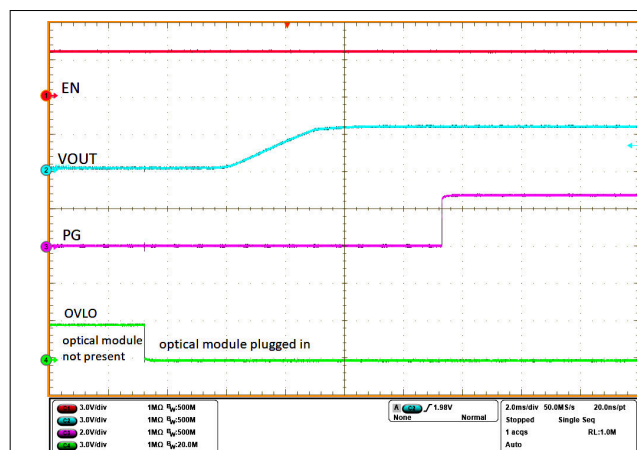

Figure 8-13. Output Voltage Profile When Optical Module is Inserted

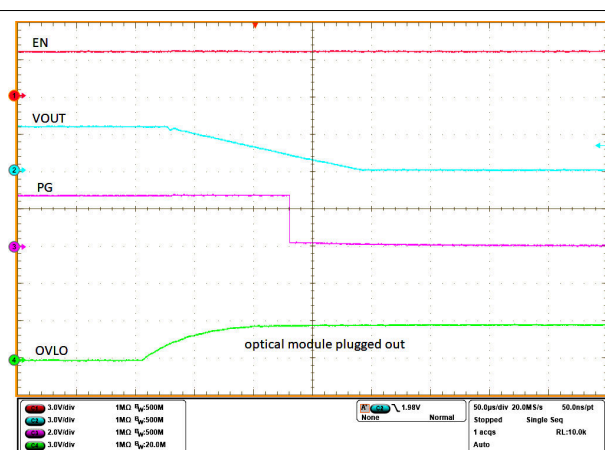

Figure 8-14. Output Voltage Profile When Optical Module is Plugged Out

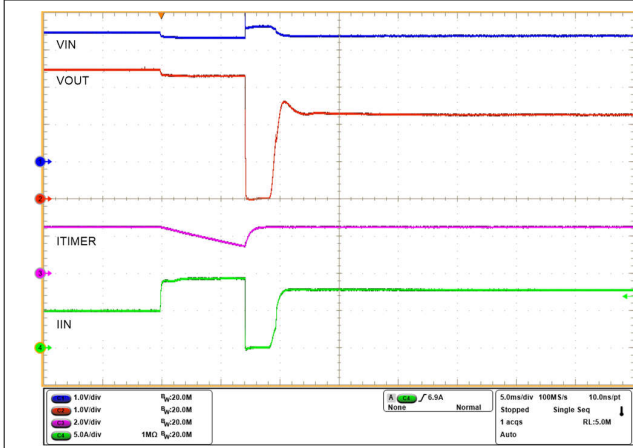

Figure 8-15. Circuit Breaker With Transient Overcurrent Blanking Interval of 6 ms; Device Restarts in Current Limit Mode

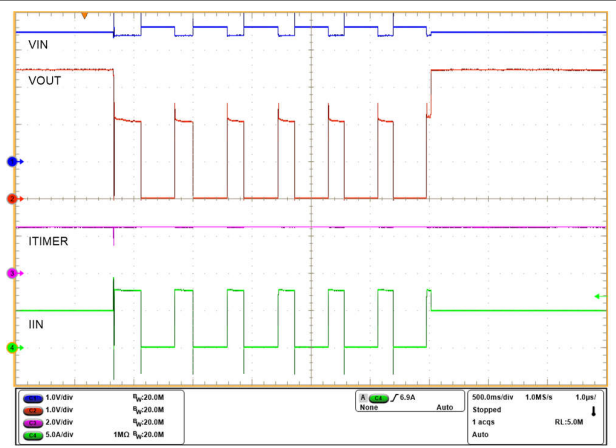

Figure 8-16. Overload Response and Recovery

8.3.2 Input Protection for 12-V Rail Applications: PCIe Cards, Storage Interfaces, and DC Fans

TPS25983 eFuse provides inrush current management and also protects the system from most common faults such as undervoltage, overvoltage, and overcurrents. The combination of high current support along with low ON-resistance makes TPS25983 an ideal protection solution for PCIe cards, storage interfaces, and DC fan loads. The external component values can be calculated by following the design procedure outlined in [Detailed Design Procedure](#). Alternatively, a spreadsheet design tool [TPS25983xx Design Calculator](#) is available for simplified design efforts.

8.3.3 Priority Power MUXing

Applications having two energy sources such as PCIe cards, tablets, and portable battery powered equipment require preference of one source to another. For example, mains power (wall-adaptor) has the priority over the internal battery back-up power. These applications demand for switchover from mains power to backup power only when main input voltage falls below a user-defined threshold. The TPS25983 devices provide a simple design for priority power multiplexing needs.

Figure 8-17 shows a typical priority power multiplexing implementation using TPS25983 devices. When the primary (priority) power source (IN1) is present and above the undervoltage (UVLO) threshold, the primary path device path powers the OUT bus irrespective of which auxiliary supply voltage condition. The device in auxiliary path is held in off condition by forcing the OVLO pin to high using the EN/UVLO signal of the primary path device. Once the primary supply voltage falls below the user-defined undervoltage threshold (UVLO), the primary path device is turned off. At the same the auxiliary, the auxiliary path device turns on and starts delivering power to the load. In this configuration, supply overvoltage protection is not available on both channels.

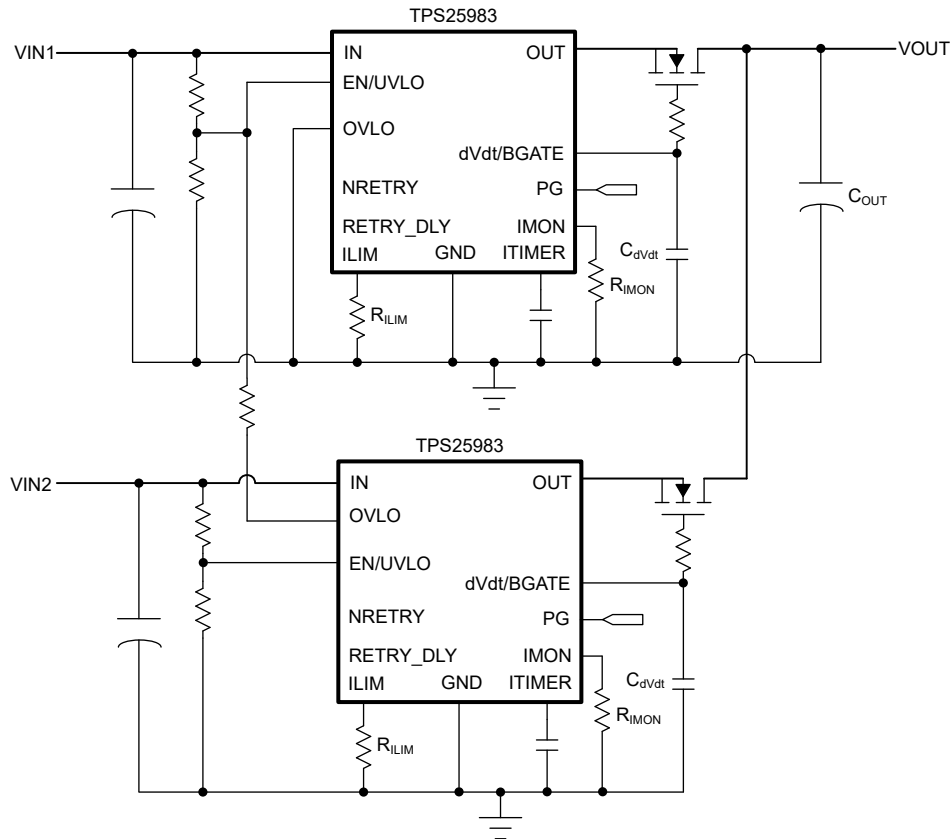

Figure 8-17. Two Devices, Priority Power MUX Configuration

The PG pins of the devices can be used as a digital indication to identify which of the two supplies is active and delivering power to the load.

A key consideration in power MUXing applications is the minimum voltage the output bus droops to during the switchover from one supply to another. This in turn depends on multiple factors including the output load current (I_{LOAD}), output bus hold-up capacitance (C_{OUT}) and switchover time (t_{SW}).

While switching from primary supply (V_{IN1}) to auxiliary supply (V_{IN2}) or vice versa, the minimum bus voltage can be calculated using Equation 30. Here, the maximum switchover time (t_{SW}) is the time taken by the device to turn on and start delivering power to the load, which is equal to the device turn on time (t_{ON}), which includes the turn on delay ($t_{D,ON}$) and rise time (t_R) determined by the dVdt capacitor (C_{dVdt}) and bus voltage.

$$V_{OUT(min)} (V) = \min(V_{IN1}, V_{IN2}) - \frac{t_{SW} (\mu s) \times I_{LOAD} (A)}{C_{OUT} (\mu F)} \quad (30)$$

Figure 8-18 and Figure 8-19 illustrate the power MUXing behavior.

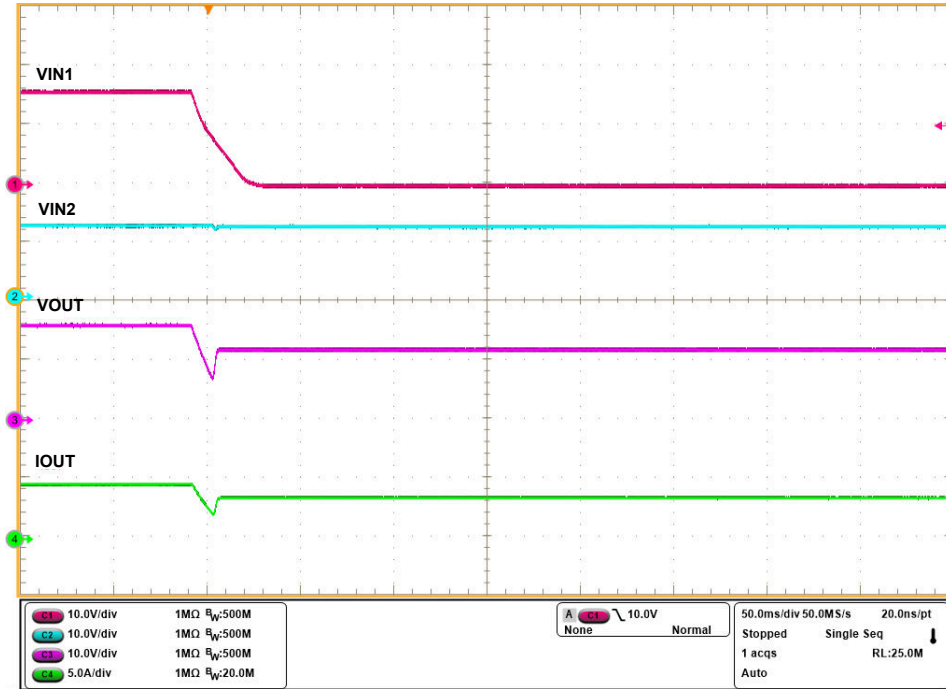

Figure 8-18. TPS25983 Power MUX, Switchover From Primary to Auxiliary Supply

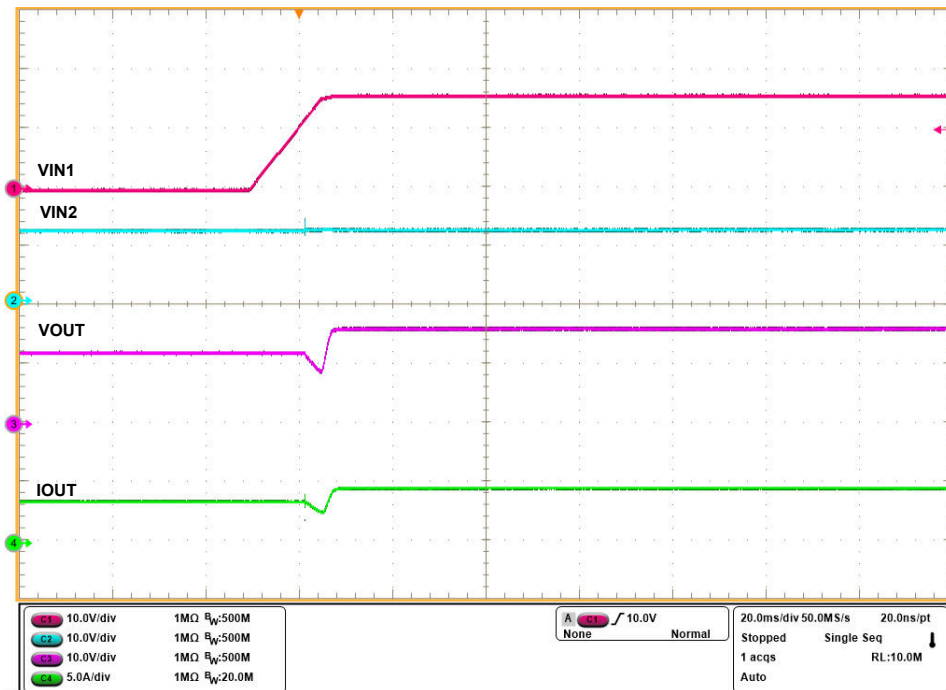

Figure 8-19. TPS25983 Power MUX, Switchover From Auxiliary to Primary Supply

Note

1. Power MUXing can be accomplished either between two similar rails (such as 12-V primary and 12-V auxiliary, 3.3-V primary and 3.3-V auxiliary) or between dissimilar rails (such as 12-V primary and 5-V auxiliary, or vice versa).
2. For power MUXing cases with skewed voltage combinations, care must be taken to design circuit components on EN/UVLO, OVLO pins for the lower voltage channel devices such that the absolute-maximum ratings on those pins are not exceeded when higher voltage is present on the other channel. Also, the dVdt pin capacitor rating must be chosen based on the highest of the two supplies. Refer to [Recommended Operating Conditions](#) table for more details.
3. Using a series resistance between EN/UVLO pin of primary path eFuse and the OVLO pin of the auxiliary path eFuse is recommended. The value of the series resistor must be at least 10 times higher than the bottom resistor of the ladder on the EN/UVLO pin of the primary path eFuse.

8.4 Power Supply Recommendations

The TPS25983 devices are designed for a supply voltage range of $2.7\text{ V} \leq V_{IN} \leq 26\text{ V}$. TI recommends an input ceramic bypass capacitor higher than $0.1\text{ }\mu\text{F}$ if the input supply is located more than a few inches from the device. The power supply must be rated higher than the set current limit to avoid voltage droops during overcurrent and short-circuit conditions.

8.4.1 Transient Protection

In the case of a short circuit and overload current limit when the device interrupts current flow, the input inductance generates a positive voltage spike on the input, and the output inductance generates a negative voltage spike on the output. The peak amplitude of voltage spikes (transients) is dependent on the value of inductance in series to the input or output of the device. Such transients can exceed the absolute maximum ratings of the device if steps are not taken to address the issue. Typical methods for addressing transients include:

- Minimize lead length and inductance into and out of the device.
- Use a large PCB GND plane.
- Use a Schottky diode across the output to absorb negative spikes.
- Use a low value ceramic capacitor $C_{IN} = 0.001\text{ }\mu\text{F}$ to $0.1\text{ }\mu\text{F}$ to absorb the energy and dampen the transients. The approximate value of input capacitance can be estimated using [Equation 31](#).

$$V_{\text{SPIKE(Absolute)}} = V_{IN} + I_{\text{LOAD}} \times \sqrt{\frac{L_{IN}}{C_{IN}}} \quad (31)$$

where

- V_{IN} is the nominal supply voltage
- I_{LOAD} is the load current
- L_{IN} equals the effective inductance seen looking into the source
- C_{IN} is the capacitance present at the input

Some of the applications may require the addition of a Transient Voltage Suppressor (TVS) to prevent transients from exceeding the absolute maximum ratings of the device. A typical circuit implementation with optional protection components (a ceramic capacitor, TVS and Schottky diode) is shown in [Figure 8-20](#).

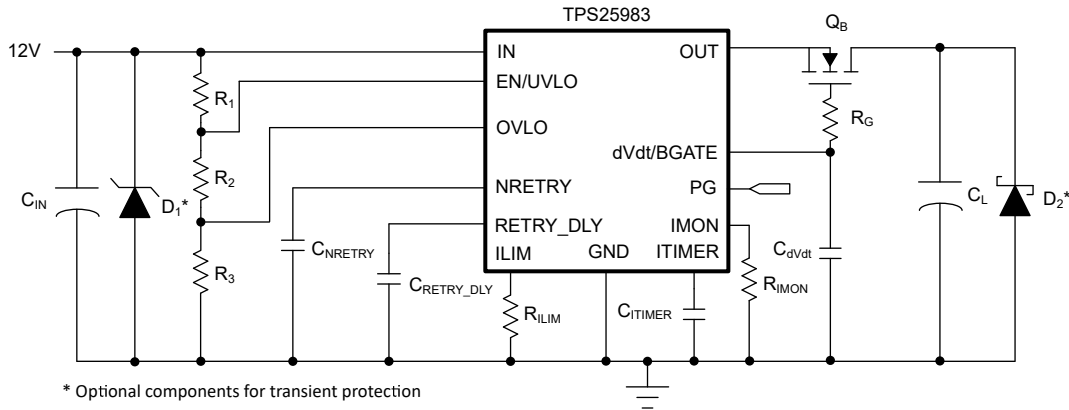

Figure 8-20. Typical Circuit Implementation With Optional Protection Components

8.4.2 Output Short-Circuit Measurements

It is difficult to obtain repeatable and similar short-circuit testing results. The following contribute to variation in results:

- Source bypassing
- Input leads
- Board layout
- Component selection
- Output shorting method
- Relative location of the short
- Instrumentation

The actual short exhibits a certain degree of randomness because it microscopically bounces and arcs. Ensure that configuration and methods are used to obtain realistic results.

Note

Do not expect to see waveforms exactly like the waveforms in this data sheet because every setup is different.

8.5 Layout

8.5.1 Layout Guidelines

- The IN Exposed Thermal Pad is used for Heat Dissipation. Connect to as much copper area as possible using an array of thermal vias. The via array also helps to minimize the voltage gradient across the VIN pad and facilitates uniform current distribution through the internal FET, which improves the current sensing and monitoring accuracy.
- For all applications, TI recommends a ceramic decoupling capacitor of 0.01 μ F or greater between IN and GND terminals. For hot-plug applications, where input power-path inductance is negligible, this capacitor can be eliminated or minimized.
- The optimal placement of the decoupling capacitor is closest to the IN and GND terminals of the device. Care must be taken to minimize the loop area formed by the bypass-capacitor connection, the IN terminal, and the GND terminal of the IC.
- High current carrying power path connections must be as short as possible and must be sized to carry at least twice the full-load current. It is recommended to use a minimum trace width of 50 mil for the OUT power connection.
- The GND terminal is the reference for all internal signals and must be isolated from any bounce due to large switching currents in the system power ground plane. It is recommended to connect the device GND to a signal ground island on the board, which in turn is connected to the system power GND plane at one point.
- Locate the support components for the following signals close to their respective connection pins - ILIM, IMON, ITIMER, RETRY_DLY, NRETRY and dVdT with the shortest possible trace routing to reduce parasitic

effects on the respective associated functions. These traces must not have any coupling to switching signals on the board.

- The ILIM pin is highly sensitive to capacitance and TI recommends to pay special attention to the layout to maintain the parasitic capacitance below 30 pF for stable operation.
- Use short traces on the RETRY_DLY and NRETRY pins to ensure the auto-retry timer delay and number of auto-retries is not altered by the additional parasitic capacitance on these pins.
- Protection devices such as TVS, snubbers, capacitors, or diodes must be placed physically close to the device they are intended to protect. These protection devices must be routed with short traces to reduce inductance. For example, TI recommends a protection Schottky diode to address negative transients due to switching of inductive loads, and it must be physically close to the OUT pins.
- Use proper layout and thermal management techniques to ensure there is no significant steady state thermal gradient between the two thermal pads on the IC. This is necessary for proper functioning of the device overtemperature protection mechanism and successful startup under all conditions.
- Obtaining acceptable performance with alternate layout schemes is possible; the [Layout Example](#) is intended as a guideline and shown to produce good results from electrical and thermal standpoint.

8.5.2 Layout Example

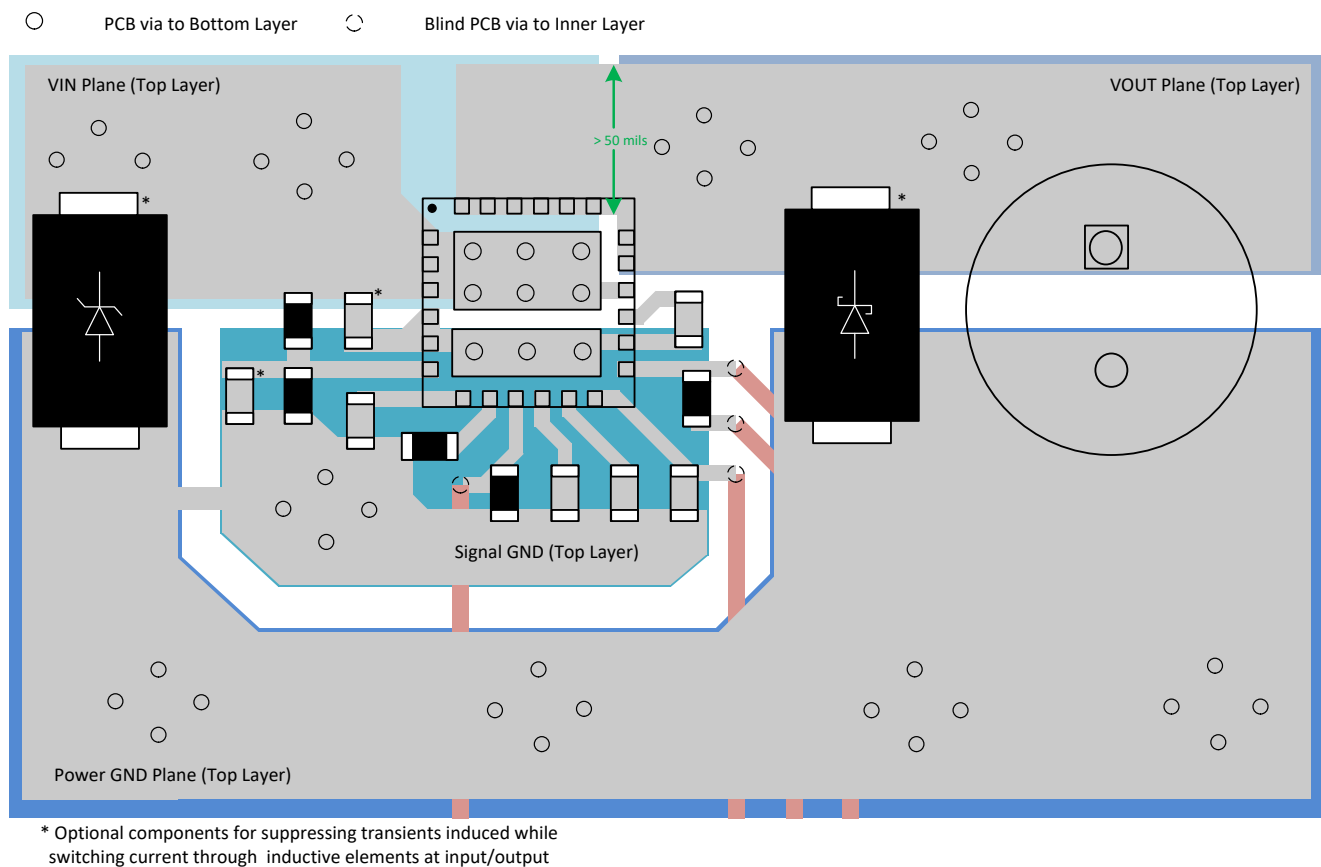

Figure 8-21. TPS25983 Example PCB Layout

9 Device and Documentation Support

9.1 Documentation Support

9.1.1 Related Documentation

For related documentation see the following:

- Texas Instruments, [Evaluation Module for TPS25983 eFuse](#), EVM user's guide
- Texas Instruments, [TPS25983xx Design Calculator](#), application

9.2 Receiving Notification of Documentation Updates

To receive notification of documentation updates, navigate to the device product folder on [ti.com](https://www.ti.com). Click on *Notifications* to register and receive a weekly digest of any product information that has changed. For change details, review the revision history included in any revised document.

9.3 Support Resources

[TI E2E™ support forums](#) are an engineer's go-to source for fast, verified answers and design help — straight from the experts. Search existing answers or ask your own question to get the quick design help you need.

Linked content is provided "AS IS" by the respective contributors. They do not constitute TI specifications and do not necessarily reflect TI's views; see TI's [Terms of Use](#).

9.4 Trademarks

TI E2E™ is a trademark of Texas Instruments.
All trademarks are the property of their respective owners.

9.5 Electrostatic Discharge Caution



This integrated circuit can be damaged by ESD. Texas Instruments recommends that all integrated circuits be handled with appropriate precautions. Failure to observe proper handling and installation procedures can cause damage.

ESD damage can range from subtle performance degradation to complete device failure. Precision integrated circuits may be more susceptible to damage because very small parametric changes could cause the device not to meet its published specifications.

9.6 Glossary

[TI Glossary](#) This glossary lists and explains terms, acronyms, and definitions.

10 Revision History

NOTE: Page numbers for previous revisions may differ from page numbers in the current version.

Changes from Revision A (October 2023) to Revision B (December 2024) Page

- Updated the value of RILIM from 82Ω to 74Ω ohms in Recommended Operating Conditions table..... **6**
- Updated [Figure 6-9](#) and [Figure 6-11](#) **10**

Changes from Revision * (August 2023) to Revision A (October 2023) Page

- Changed from Advance Information to Production Data **1**

11 Mechanical, Packaging, and Orderable Information

The following pages include mechanical, packaging, and orderable information. This information is the most current data available for the designated devices. This data is subject to change without notice and revision of this document. For browser-based versions of this data sheet, refer to the left-hand navigation.

PACKAGING INFORMATION

Orderable part number	Status (1)	Material type (2)	Package Pins	Package qty Carrier	RoHS (3)	Lead finish/ Ball material (4)	MSL rating/ Peak reflow (5)	Op temp (°C)	Part marking (6)
TPS259830LNRGER	Active	Production	VQFN (RGE) 24	3000 LARGE T&R	Yes	NIPDAUAG	Level-2-260C-1 YEAR	-40 to 125	TP2598 30LN
TPS259830LNRGER.A	Active	Production	VQFN (RGE) 24	3000 LARGE T&R	Yes	NIPDAUAG	Level-2-260C-1 YEAR	-40 to 125	TP2598 30LN
TPS259830ONRGER	Active	Production	VQFN (RGE) 24	3000 LARGE T&R	Yes	NIPDAUAG	Level-2-260C-1 YEAR	-40 to 125	TP2598 30ON
TPS259830ONRGER.A	Active	Production	VQFN (RGE) 24	3000 LARGE T&R	Yes	NIPDAUAG	Level-2-260C-1 YEAR	-40 to 125	TP2598 30ON

(1) **Status:** For more details on status, see our [product life cycle](#).

(2) **Material type:** When designated, preproduction parts are prototypes/experimental devices, and are not yet approved or released for full production. Testing and final process, including without limitation quality assurance, reliability performance testing, and/or process qualification, may not yet be complete, and this item is subject to further changes or possible discontinuation. If available for ordering, purchases will be subject to an additional waiver at checkout, and are intended for early internal evaluation purposes only. These items are sold without warranties of any kind.

(3) **RoHS values:** Yes, No, RoHS Exempt. See the [TI RoHS Statement](#) for additional information and value definition.

(4) **Lead finish/Ball material:** Parts may have multiple material finish options. Finish options are separated by a vertical ruled line. Lead finish/Ball material values may wrap to two lines if the finish value exceeds the maximum column width.

(5) **MSL rating/Peak reflow:** The moisture sensitivity level ratings and peak solder (reflow) temperatures. In the event that a part has multiple moisture sensitivity ratings, only the lowest level per JEDEC standards is shown. Refer to the shipping label for the actual reflow temperature that will be used to mount the part to the printed circuit board.

(6) **Part marking:** There may be an additional marking, which relates to the logo, the lot trace code information, or the environmental category of the part.

Multiple part markings will be inside parentheses. Only one part marking contained in parentheses and separated by a "-" will appear on a part. If a line is indented then it is a continuation of the previous line and the two combined represent the entire part marking for that device.

Important Information and Disclaimer: The information provided on this page represents TI's knowledge and belief as of the date that it is provided. TI bases its knowledge and belief on information provided by third parties, and makes no representation or warranty as to the accuracy of such information. Efforts are underway to better integrate information from third parties. TI has taken and continues to take reasonable steps to provide representative and accurate information but may not have conducted destructive testing or chemical analysis on incoming materials and chemicals. TI and TI suppliers consider certain information to be proprietary, and thus CAS numbers and other limited information may not be available for release.

In no event shall TI's liability arising out of such information exceed the total purchase price of the TI part(s) at issue in this document sold by TI to Customer on an annual basis.

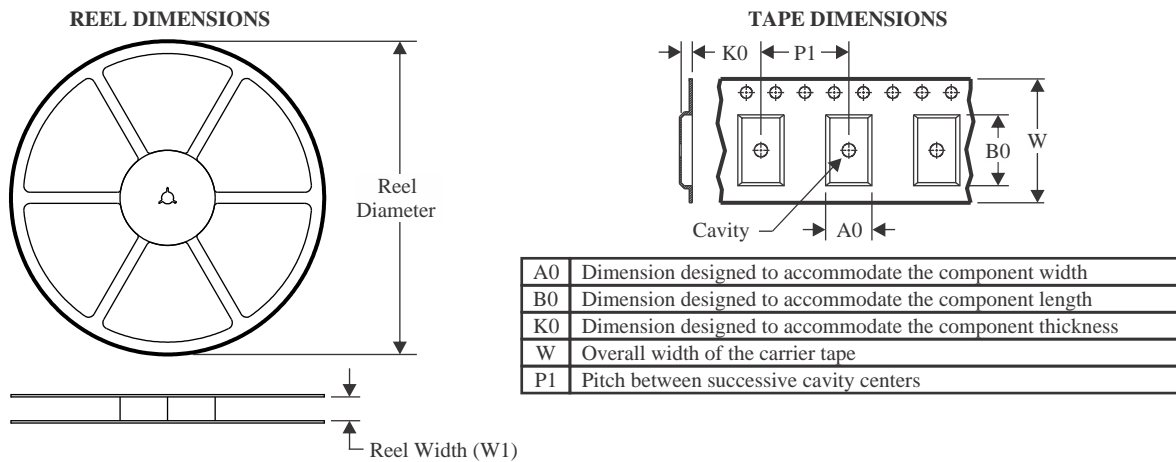
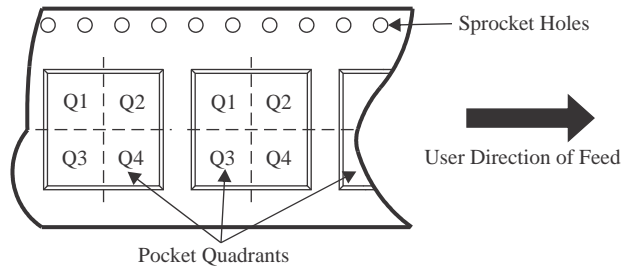
TAPE AND REEL INFORMATION

QUADRANT ASSIGNMENTS FOR PIN 1 ORIENTATION IN TAPE

*All dimensions are nominal

Device	Package Type	Package Drawing	Pins	SPQ	Reel Diameter (mm)	Reel Width W1 (mm)	A0 (mm)	B0 (mm)	K0 (mm)	P1 (mm)	W (mm)	Pin1 Quadrant
TPS259830LNRGER	VQFN	RGE	24	3000	330.0	12.4	4.35	4.35	1.1	8.0	12.0	Q2
TPS259830ONRGER	VQFN	RGE	24	3000	330.0	12.4	4.35	4.35	1.1	8.0	12.0	Q2

TAPE AND REEL BOX DIMENSIONS

*All dimensions are nominal

Device	Package Type	Package Drawing	Pins	SPQ	Length (mm)	Width (mm)	Height (mm)
TPS259830LNRGER	VQFN	RGE	24	3000	338.0	355.0	35.0
TPS259830ONRGER	VQFN	RGE	24	3000	338.0	355.0	35.0

RGE 24

GENERIC PACKAGE VIEW

VQFN - 1 mm max height

PLASTIC QUAD FLATPACK - NO LEAD

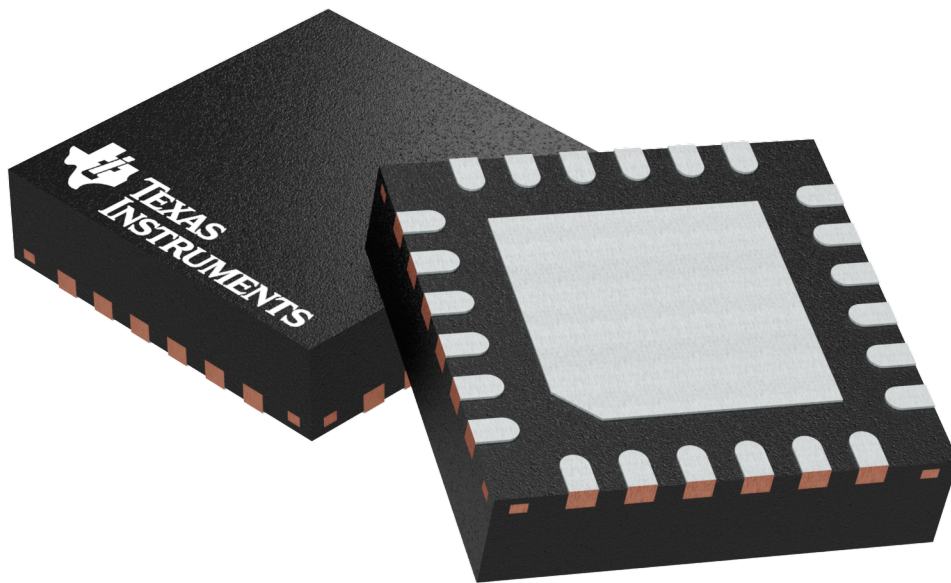

Images above are just a representation of the package family, actual package may vary.
Refer to the product data sheet for package details.

4204104/H

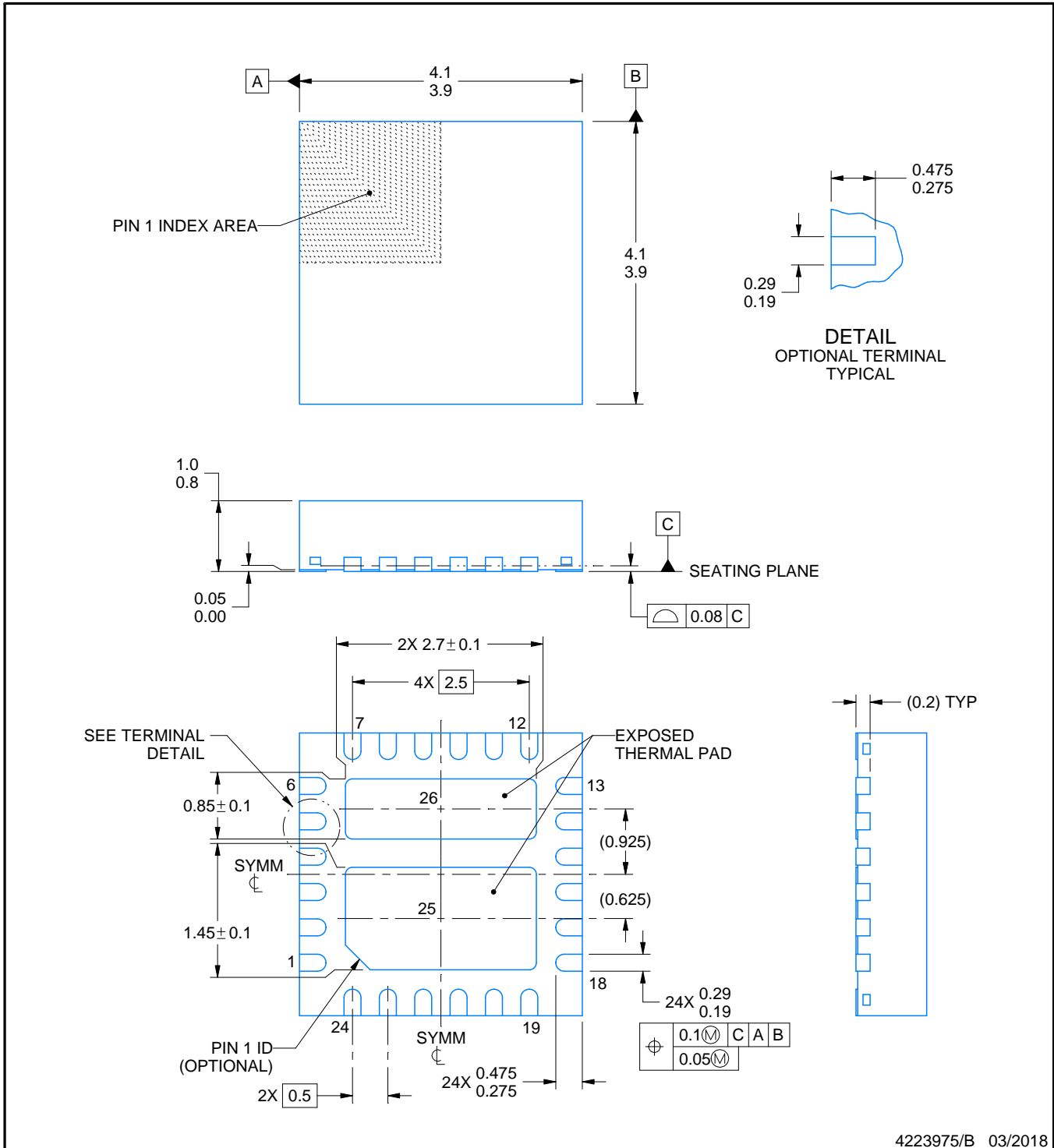

4223975/B 03/2018

NOTES:

1. All linear dimensions are in millimeters. Any dimensions in parenthesis are for reference only. Dimensioning and tolerancing per ASME Y14.5M.
2. This drawing is subject to change without notice.
3. The package thermal pad must be soldered to the printed circuit board for thermal and mechanical performance.

EXAMPLE BOARD LAYOUT

RGE0024M

VQFN - 1 mm max height

PLASTIC QUAD FLATPACK - NO LEAD

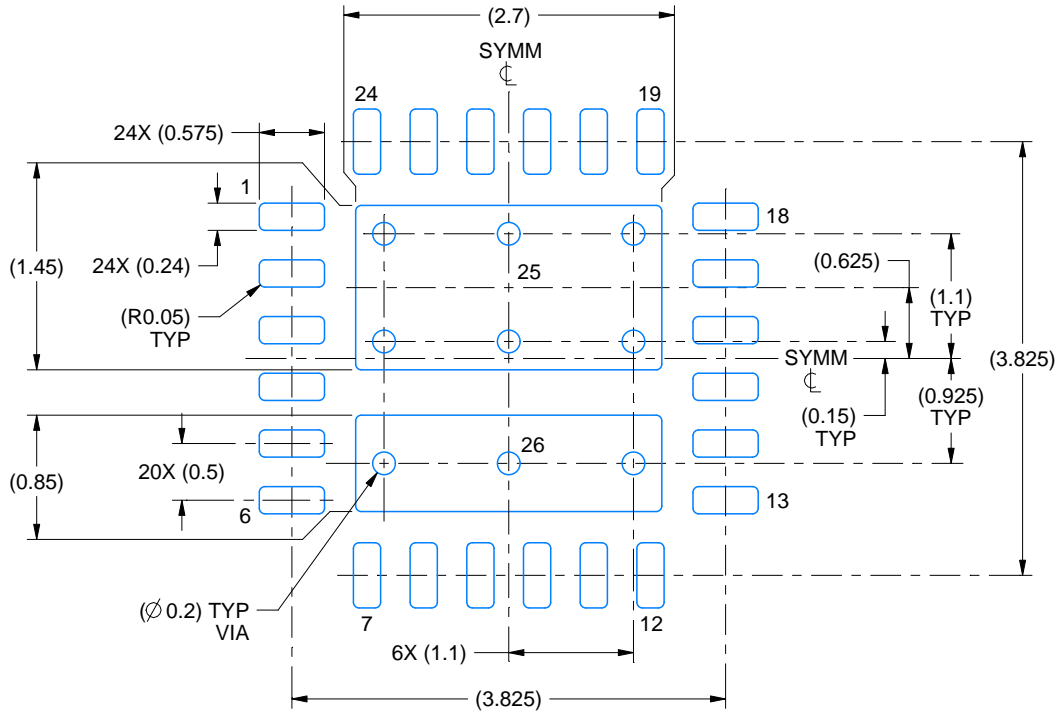

LAND PATTERN EXAMPLE
EXPOSED METAL SHOWN
SCALE:15X

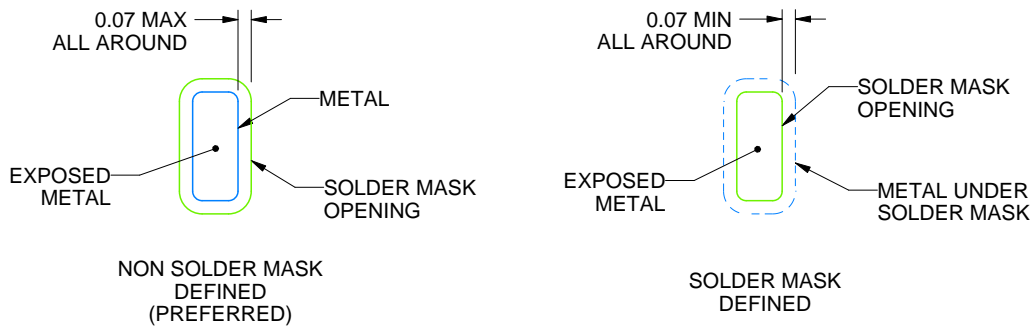

SOLDER MASK DETAILS

4223975/B 03/2018

NOTES: (continued)

- This package is designed to be soldered to a thermal pad on the board. For more information, see Texas Instruments literature number SLUA271 (www.ti.com/lit/sluea271).
- Vias are optional depending on application, refer to device data sheet. If any vias are implemented, refer to their locations shown on this view. It is recommended that vias under paste be filled, plugged or tented.

EXAMPLE STENCIL DESIGN

RGE0024M

VQFN - 1 mm max height

PLASTIC QUAD FLATPACK - NO LEAD

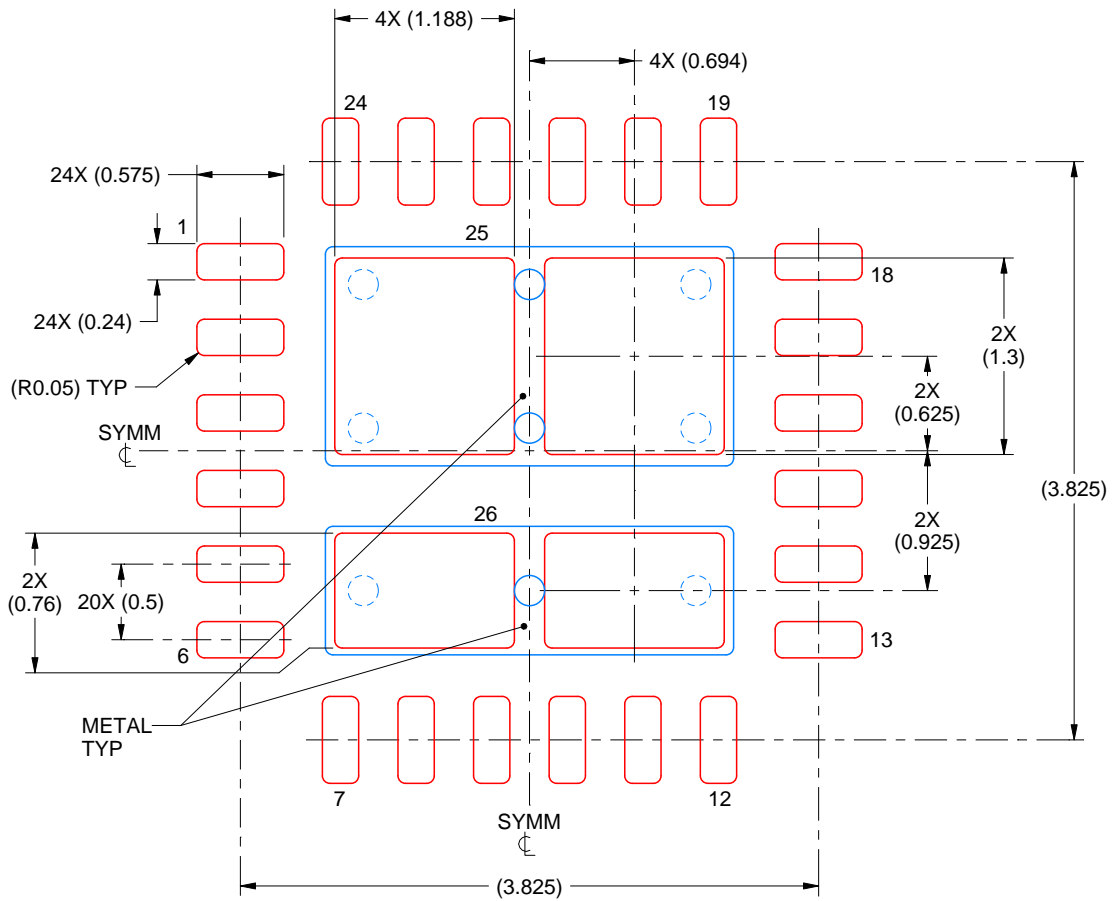

SOLDER PASTE EXAMPLE
 BASED ON 0.125 mm THICK STENCIL

EXPOSED PAD 25
 78% PRINTED SOLDER COVERAGE BY AREA UNDER PACKAGE
 SCALE:20X

4223975/B 03/2018

NOTES: (continued)

6. Laser cutting apertures with trapezoidal walls and rounded corners may offer better paste release. IPC-7525 may have alternate design recommendations.

IMPORTANT NOTICE AND DISCLAIMER

TI PROVIDES TECHNICAL AND RELIABILITY DATA (INCLUDING DATASHEETS), DESIGN RESOURCES (INCLUDING REFERENCE DESIGNS), APPLICATION OR OTHER DESIGN ADVICE, WEB TOOLS, SAFETY INFORMATION, AND OTHER RESOURCES "AS IS" AND WITH ALL FAULTS, AND DISCLAIMS ALL WARRANTIES, EXPRESS AND IMPLIED, INCLUDING WITHOUT LIMITATION ANY IMPLIED WARRANTIES OF MERCHANTABILITY, FITNESS FOR A PARTICULAR PURPOSE OR NON-INFRINGEMENT OF THIRD PARTY INTELLECTUAL PROPERTY RIGHTS.

These resources are intended for skilled developers designing with TI products. You are solely responsible for (1) selecting the appropriate TI products for your application, (2) designing, validating and testing your application, and (3) ensuring your application meets applicable standards, and any other safety, security, regulatory or other requirements.

These resources are subject to change without notice. TI grants you permission to use these resources only for development of an application that uses the TI products described in the resource. Other reproduction and display of these resources is prohibited. No license is granted to any other TI intellectual property right or to any third party intellectual property right. TI disclaims responsibility for, and you fully indemnify TI and its representatives against any claims, damages, costs, losses, and liabilities arising out of your use of these resources.

TI's products are provided subject to [TI's Terms of Sale](#), [TI's General Quality Guidelines](#), or other applicable terms available either on ti.com or provided in conjunction with such TI products. TI's provision of these resources does not expand or otherwise alter TI's applicable warranties or warranty disclaimers for TI products. Unless TI explicitly designates a product as custom or customer-specified, TI products are standard, catalog, general purpose devices.

TI objects to and rejects any additional or different terms you may propose.

Copyright © 2026, Texas Instruments Incorporated

Last updated 10/2025

Looking for pricing, stock, or lifecycle information?

Click below to explore more details on WIN SOURCE:

 [View SI-46004-F on WIN SOURCE](#)

 [Bel Fuse Inc. Information](#)

Optimize Your Supply Chain with WIN SOURCE Solutions

-  Global Sourcing Solution
-  Obsolete Management
-  Cost Control Management
-  Shortage Management
-  Alternative Solution
-  Excess Inventory Management