



# THE DATASHEET OF SN74HC04ANS



## 20-BIT FET BUS SWITCH

### 2.5-V/3.3-V LOW-VOLTAGE BUS SWITCH WITH 5-V-TOLERANT LEVEL SHIFTER

Check for Samples: [SN74CB3T16210](#)

#### FEATURES

- Member of the Texas Instruments Widebus™ Family
- Output Voltage Translation Tracks  $V_{CC}$
- Supports Mixed-Mode Signal Operation on All Data I/O Ports
  - 5-V Input Down to 3.3-V Output Level Shift With 3.3-V  $V_{CC}$
  - 5-V/3.3-V Input Down to 2.5-V Output Level Shift With 2.5-V  $V_{CC}$
- 5-V-Tolerant I/Os With Device Powered Up or Powered Down
- Bidirectional Data Flow With Near-Zero Propagation Delay
- Low ON-State Resistance ( $r_{on}$ ) Characteristics ( $r_{on} = 5 \Omega$  Typ)
- Low Input/Output Capacitance Minimizes Loading ( $C_{io(OFF)} = 5$  pF Typ)
- Data and Control Inputs Provide Undershoot Clamp Diodes
- Low Power Consumption ( $I_{CC} = 40 \mu A$  Max)
- $V_{CC}$  Operating Range From 2.3 V to 3.6 V
- Data I/Os Support 0- to 5-V Signaling Levels (0.8 V, 1.2 V, 1.5 V, 1.8 V, 2.5 V, 3.3 V, 5 V)
- Control Inputs Can Be Driven by TTL or 5-V/3.3-V CMOS Outputs
- $I_{off}$  Supports Partial-Power-Down Mode Operation
- Latch-Up Performance Exceeds 250 mA Per JESD 17
- ESD Performance Tested Per JESD 22
  - 2000-V Human-Body Model (A114-B, Class II)
  - 1000-V Charged-Device Model (C101)

- Supports Digital Applications: Level Translation, PCI Interface, USB Interface, Memory Interleaving, and Bus Isolation
- Ideal for Low-Power Portable Equipment

DGG OR DGV PACKAGE  
(TOP VIEW)

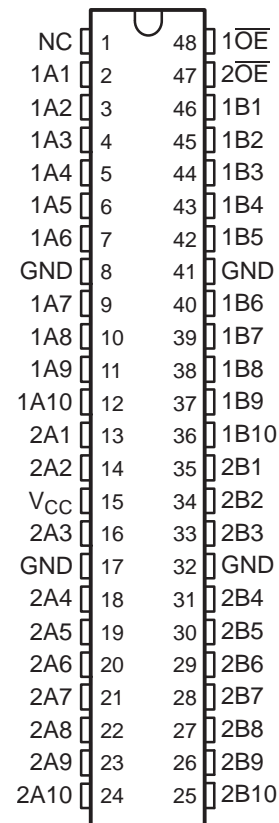

NC - No internal connection

#### DESCRIPTION/ORDERING INFORMATION

The SN74CB3T16210 is a high-speed TTL-compatible FET bus switch with low ON-state resistance ( $r_{on}$ ), allowing for minimal propagation delay. The device fully supports mixed-mode signal operation on all data I/O ports by providing voltage translation that tracks  $V_{CC}$ . The SN74CB3T16210 supports systems using 5-V TTL, 3.3-V LVTTTL, and 2.5-V CMOS switching standards, as well as user-defined switching levels (see [Figure 1](#)).



Please be aware that an important notice concerning availability, standard warranty, and use in critical applications of Texas Instruments semiconductor products and disclaimers thereto appears at the end of this data sheet.

Widebus is a trademark of Texas Instruments.

## DESCRIPTION/ORDERING INFORMATION (CONTINUED)

The SN74CB3T16210 is organized as two 10-bit bus switches with separate output-enable ( $\overline{1OE}$ ,  $\overline{2OE}$ ) inputs. It can be used as two 10-bit bus switches or as one 20-bit bus switch. When  $\overline{OE}$  is low, the associated 10-bit bus switch is ON, and the A port is connected to the B port, allowing bidirectional data flow between ports. When  $\overline{OE}$  is high, the associated 10-bit bus switch is OFF, and a high-impedance state exists between the A and B ports.

This device is fully specified for partial-power-down applications using  $I_{off}$ . The  $I_{off}$  feature ensures that damaging current will not backflow through the device when it is powered down. The device has isolation during power off.

To ensure the high-impedance state during power up or power down,  $\overline{OE}$  should be tied to  $V_{CC}$  through a pullup resistor; the minimum value of the resistor is determined by the current-sinking capability of the driver.

## ORDERING INFORMATION

$T_A$	PACKAGE <sup>(1)</sup>		ORDERABLE PART NUMBER	TOP-SIDE MARKING
-40°C to 85°C	TSSOP – DGG	Tape and reel	SN74CB3T16210DGGR	CB3T16210
	TVSOP – DGV	Tape and reel	SN74CB3T16210DGVR	KR210

(1) Package drawings, standard packing quantities, thermal data, symbolization, and PCB design guidelines are available at [www.ti.com/sc/package](http://www.ti.com/sc/package).

## FUNCTION TABLE (EACH 10-BIT BUS SWITCH)

INPUT $\overline{OE}$	INPUT/OUTPUT A	FUNCTION
L	B	A port = B port
H	Z	Disconnect

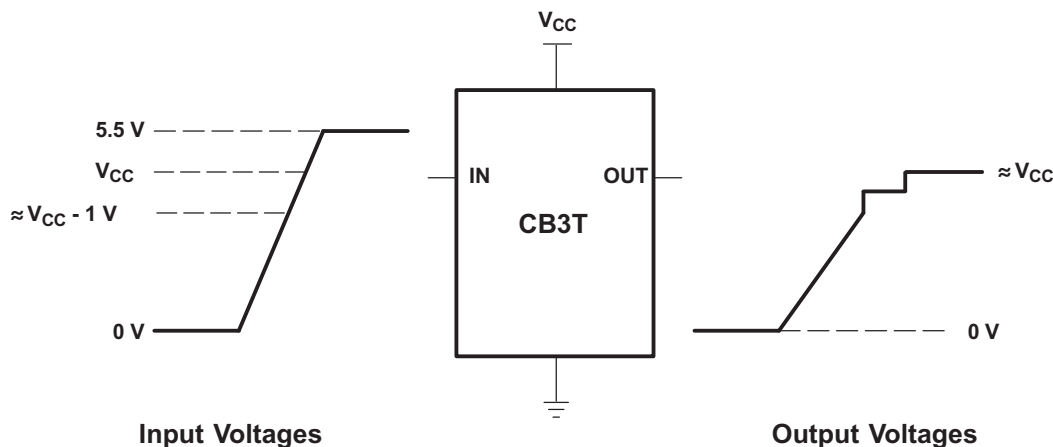

If the input high voltage ( $V_{IH}$ ) level is greater than or equal to  $V_{CC} + 1V$ , and less than or equal to 5.5 V, the output high voltage ( $V_{OH}$ ) level will be equal to approximately the  $V_{CC}$  voltage level.

**Figure 1. Typical DC Voltage Translation Characteristics**

**GQL PACKAGE  
(TOP VIEW)**

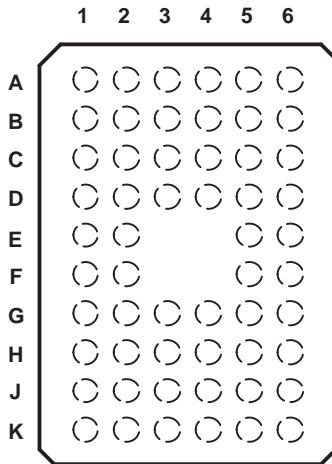

**TERMINAL ASSIGNMENTS<sup>(1)</sup>**

	1	2	3	4	5	6
<b>A</b>	1A2	1A1	NC	$\overline{1OE}$	$\overline{2OE}$	1B1
<b>B</b>	1A5	1A4	1A3	1B2	1B3	1B4
<b>C</b>	NC	GND	1A6	1B5	1B6	NC
<b>D</b>	1A8	NC	1A7	NC	1B7	1B8
<b>E</b>	1A10	1A9			1B9	1B10
<b>F</b>	2A1	2A2			2B2	2B1
<b>G</b>	V <sub>CC</sub>	GND	2A3	GND	2B4	2B3
<b>H</b>	NC	NC	2A4	2B5	NC	NC
<b>J</b>	2A5	2A6	2A7	2B7	2B6	2B5
<b>K</b>	2A8	2A9	2A10	2B10	2B9	2B8

(1) NC - No internal connection

**LOGIC DIAGRAM (POSITIVE LOGIC)**

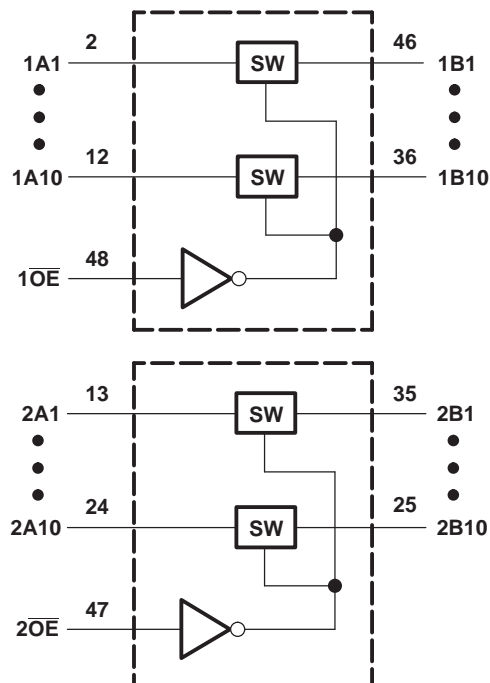

### SIMPLIFIED SCHEMATIC, EACH FET SWITCH (SW)

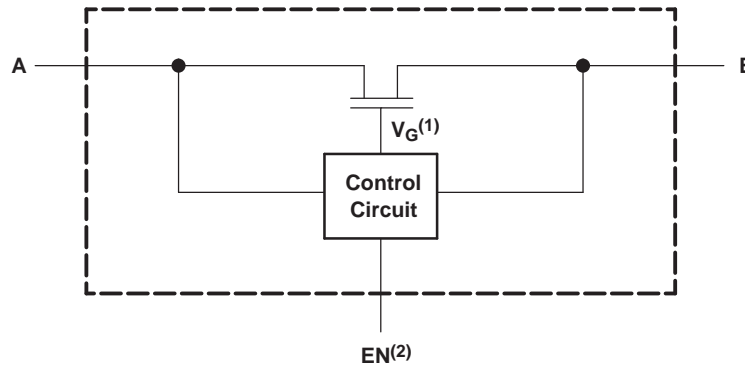

- (1) Gate voltage ( $V_G$ ) is equal to approximately  $V_{CC} + V_T$  when the switch is ON and  $V_I > V_{CC} + V_T$ .  
 (2) EN is the internal enable signal applied to the switch.

### Absolute Maximum Ratings<sup>(1)</sup>

over operating free-air temperature range (unless otherwise noted)

			MIN	MAX	UNIT
$V_{CC}$	Supply voltage range		-0.5	7	V
$V_{IN}$	Control input voltage range <sup>(2) (3)</sup>		-0.5	7	V
$V_{I/O}$	Switch I/O voltage range <sup>(2) (3) (4)</sup>		-0.5	7	V
$I_{IK}$	Control input clamp current	$V_{IN} < 0$		-50	mA
$I_{I/OK}$	I/O port clamp current	$V_{I/O} < 0$		-50	mA
$I_{IO}$	ON-state switch current <sup>(5)</sup>			±128	mA
	Continuous current through $V_{CC}$ or GND			±100	mA
$\theta_{JA}$	Package thermal impedance <sup>(6)</sup>	DGG package		70	°C/W
		DGV package		58	
$T_{stg}$	Storage temperature range		-65	150	°C

- (1) Stresses beyond those listed under "absolute maximum ratings" may cause permanent damage to the device. These are stress ratings only, and functional operation of the device at these or any other conditions beyond those indicated under "recommended operating conditions" is not implied. Exposure to absolute-maximum-rated conditions for extended periods may affect device reliability.  
 (2) All voltages are with respect to ground unless otherwise specified.  
 (3) The input and output voltage ratings may be exceeded if the input and output clamp-current ratings are observed.  
 (4)  $V_I$  and  $V_O$  are used to denote specific conditions for  $V_{I/O}$ .  
 (5)  $I_I$  and  $I_O$  are used to denote specific conditions for  $I_{I/O}$ .  
 (6) The package thermal impedance is calculated in accordance with JESD 51-7.

**Recommended Operating Conditions<sup>(1)</sup>**

		MIN	MAX	UNIT	
V <sub>CC</sub>	Supply voltage	2.3	3.6	V	
V <sub>IH</sub>	High-level control input voltage	V <sub>CC</sub> = 2.3 V to 2.7 V	1.7	5.5	V
		V <sub>CC</sub> = 2.7 V to 3.6 V	2	5.5	
V <sub>IL</sub>	Low-level control input voltage	V <sub>CC</sub> = 2.3 V to 2.7 V	0	0.7	V
		V <sub>CC</sub> = 2.7 V to 3.6 V	0	0.8	
V <sub>I/O</sub>	Data input/output voltage	0	5.5	V	
T <sub>A</sub>	Operating free-air temperature	-40	85	°C	

(1) All unused control inputs of the device must be held at V<sub>CC</sub> or GND to ensure proper device operation. Refer to the TI application report, *Implications of Slow or Floating CMOS Inputs*, literature number SCBA004.

**Electrical Characteristics<sup>(1)</sup>**

PARAMETER		TEST CONDITIONS	T <sub>A</sub> = -40°C TO 85°C			UNIT	
			MIN	TYP <sup>(2)</sup>	MAX		
V <sub>IK</sub>		V <sub>CC</sub> = 3 V, I <sub>I</sub> = -18 mA			-1.2	V	
V <sub>OH</sub>		See <a href="#">Figure 3</a> and <a href="#">Figure 4</a>					
I <sub>IN</sub>	Control inputs	V <sub>CC</sub> = 3.6 V, V <sub>IN</sub> = 3.6 V to 5.5 V or GND			±10	µA	
I <sub>I</sub>		V <sub>CC</sub> = 3.6 V, Switch ON, V <sub>IN</sub> = V <sub>CC</sub> or GND	V <sub>I</sub> = V <sub>CC</sub> - 0.7 V to 5.5 V		±20	µA	
			V <sub>I</sub> = 0.7 V to V <sub>CC</sub> - 0.7 V		-40		
			V <sub>I</sub> = 0 to 0.7 V		±5		
I <sub>OZ</sub> <sup>(3)</sup>		V <sub>CC</sub> = 3.6 V, V <sub>O</sub> = 0 to 5.5 V, V <sub>I</sub> = 0, Switch OFF, V <sub>IN</sub> = V <sub>CC</sub> or GND			±10	µA	
I <sub>off</sub>		V <sub>CC</sub> = 0, V <sub>O</sub> = 0 to 5.5 V, V <sub>I</sub> = 0,			10	µA	
I <sub>CC</sub>		V <sub>CC</sub> = 3.6 V, I <sub>I/O</sub> = 0, Switch ON or OFF, V <sub>IN</sub> = V <sub>CC</sub> or GND	V <sub>I</sub> = V <sub>CC</sub> or GND		40	µA	
			V <sub>I</sub> = 5.5 V		40		
ΔI <sub>CC</sub> <sup>(4)</sup>	Control inputs	V <sub>CC</sub> = 3 V to 3.6 V, One input at V <sub>CC</sub> - 0.6 V, Other inputs at V <sub>CC</sub> or GND			300	µA	
C <sub>in</sub>	Control inputs	V <sub>CC</sub> = 3.3 V, V <sub>IN</sub> = V <sub>CC</sub> or GND			4	pF	
C <sub>io(OFF)</sub>		V <sub>CC</sub> = 3.3 V, V <sub>I/O</sub> = 5.5 V, 3.3 V, or GND, Switch OFF, V <sub>IN</sub> = V <sub>CC</sub> or GND			5	pF	
C <sub>io(ON)</sub>		V <sub>CC</sub> = 3.3 V, Switch ON, V <sub>IN</sub> = V <sub>CC</sub> or GND	V <sub>I/O</sub> = 5.5 V or 3.3 V		5	pF	
			V <sub>I/O</sub> = GND		13		
r <sub>on</sub> <sup>(5)</sup>		V <sub>CC</sub> = 2.3 V, TYP at V <sub>CC</sub> = 2.5 V, V <sub>I</sub> = 0	I <sub>O</sub> = 24 mA		5	Ω	
			I <sub>O</sub> = 16 mA		5		
		V <sub>CC</sub> = 3 V, V <sub>I</sub> = 0	I <sub>O</sub> = 64 mA		5		8.5
			I <sub>O</sub> = 32 mA		5		

(1) V<sub>IN</sub> and I<sub>IN</sub> refer to control inputs. V<sub>I</sub>, V<sub>O</sub>, I<sub>I</sub>, and I<sub>O</sub> refer to data pins.

(2) All typical values are at V<sub>CC</sub> = 3.3 V (unless otherwise noted), T<sub>A</sub> = 25°C.

(3) For I/O ports, the parameter I<sub>OZ</sub> includes the input leakage current.

(4) This is the increase in supply current for each input that is at the specified TTL voltage level, rather than V<sub>CC</sub> or GND.

(5) Measured by the voltage drop between A and B terminals at the indicated current through the switch. ON-state resistance is determined by the lower of the voltages of the two (A or B) terminals.

## Switching Characteristics

for  $V_{CC} = 2.5 \text{ V} \pm 0.2 \text{ V}$  (see [Figure 2](#))

PARAMETER	FROM (INPUT)	TO (OUTPUT)	$V_{CC} = 2.5 \text{ V} \pm 0.2 \text{ V}$		$V_{CC} = 3.3 \text{ V} \pm 0.3 \text{ V}$		UNIT
			MIN	MAX	MIN	MAX	
$t_{pd}^{(1)}$	A or B	B or A		0.15		0.25	ns
$t_{en}$	$\overline{OE}$	A or B	1	12	1	10	ns
$t_{dis}$	$\overline{OE}$	A or B	1	7.5	1	8.5	ns

- (1) The propagation delay is the calculated RC time constant of the typical ON-state resistance of the switch and the specified load capacitance, when driven by an ideal voltage source (zero output impedance).

PARAMETER MEASUREMENT INFORMATION

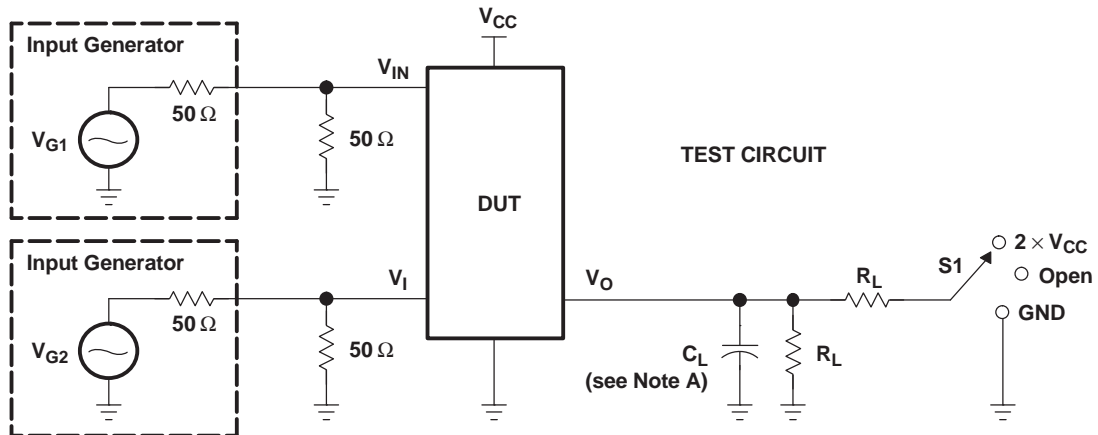

TEST	V <sub>CC</sub>	S1	R <sub>L</sub>	V <sub>I</sub>	C <sub>L</sub>	V <sub>Δ</sub>
t <sub>pd(s)</sub>	2.5 V ± 0.2 V	Open	500 Ω	3.6 V or GND	30 pF	
	3.3 V ± 0.3 V	Open	500 Ω	5.5 V or GND	50 pF	
t <sub>PLZ</sub> /t <sub>PZL</sub>	2.5 V ± 0.2 V	2 × V <sub>CC</sub>	500 Ω	GND	30 pF	0.15 V
	3.3 V ± 0.3 V	2 × V <sub>CC</sub>	500 Ω	GND	50 pF	0.3 V
t <sub>PHZ</sub> /t <sub>PZH</sub>	2.5 V ± 0.2 V	Open	500 Ω	3.6 V	30 pF	0.15 V
	3.3 V ± 0.3 V	Open	500 Ω	5.5 V	50 pF	0.3 V

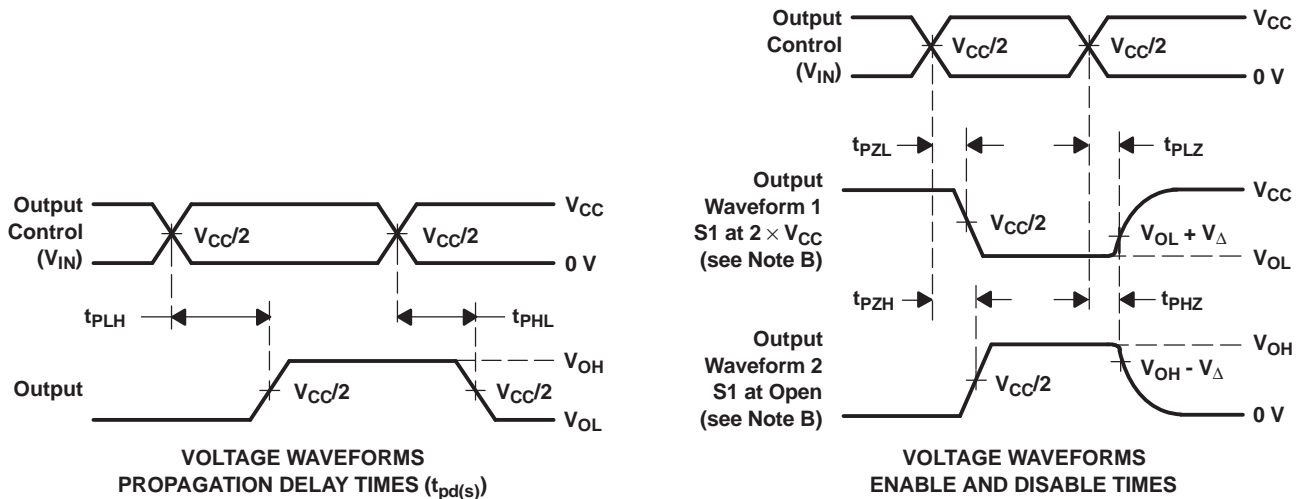

- NOTES: A. C<sub>L</sub> includes probe and jig capacitance.  
 B. Waveform 1 is for an output with internal conditions such that the output is low, except when disabled by the output control. Waveform 2 is for an output with internal conditions such that the output is high, except when disabled by the output control.  
 C. All input pulses are supplied by generators having the following characteristics: PRR ≤ 10 MHz, Z<sub>O</sub> = 50 Ω, t<sub>r</sub> ≤ 2.5 ns, t<sub>f</sub> ≤ 2.5 ns.  
 D. The outputs are measured one at a time, with one transition per measurement.  
 E. t<sub>PLZ</sub> and t<sub>PHZ</sub> are the same as t<sub>dis</sub>.  
 F. t<sub>PZL</sub> and t<sub>PZH</sub> are the same as t<sub>en</sub>.  
 G. t<sub>PLH</sub> and t<sub>PHL</sub> are the same as t<sub>pd(s)</sub>. The t<sub>pd</sub> propagation delay is the calculated RC time constant of the typical ON-state resistance of the switch and the specified load capacitance, when driven by an ideal voltage source (zero output impedance).  
 H. All parameters and waveforms are not applicable to all devices.

Figure 2. Test Circuit and Voltage Waveforms

TYPICAL CHARACTERISTICS

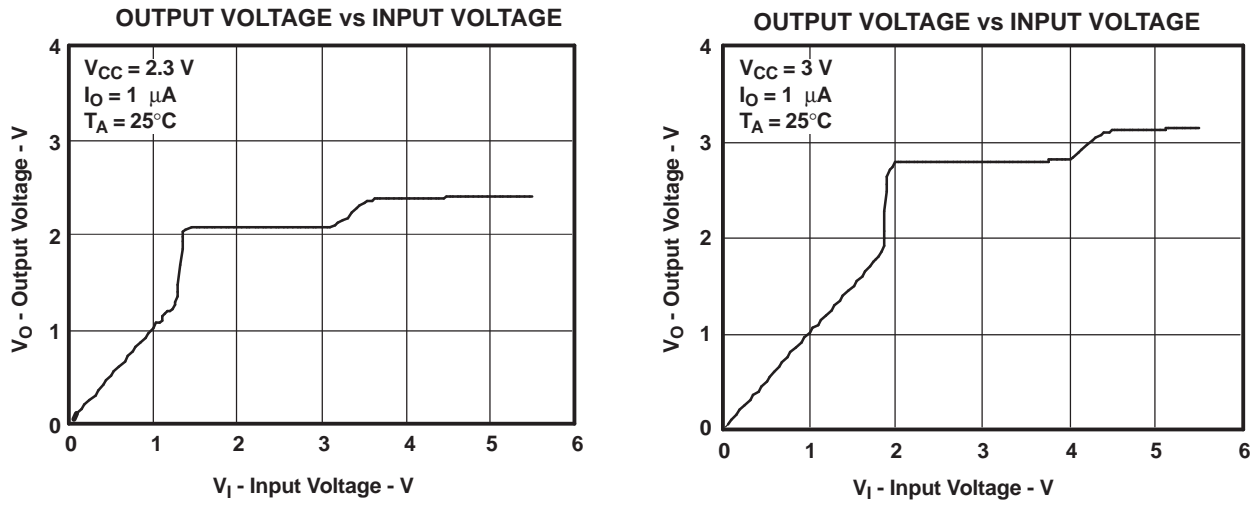

Figure 3. Data Output Voltage vs Data Input Voltage

TYPICAL CHARACTERISTICS

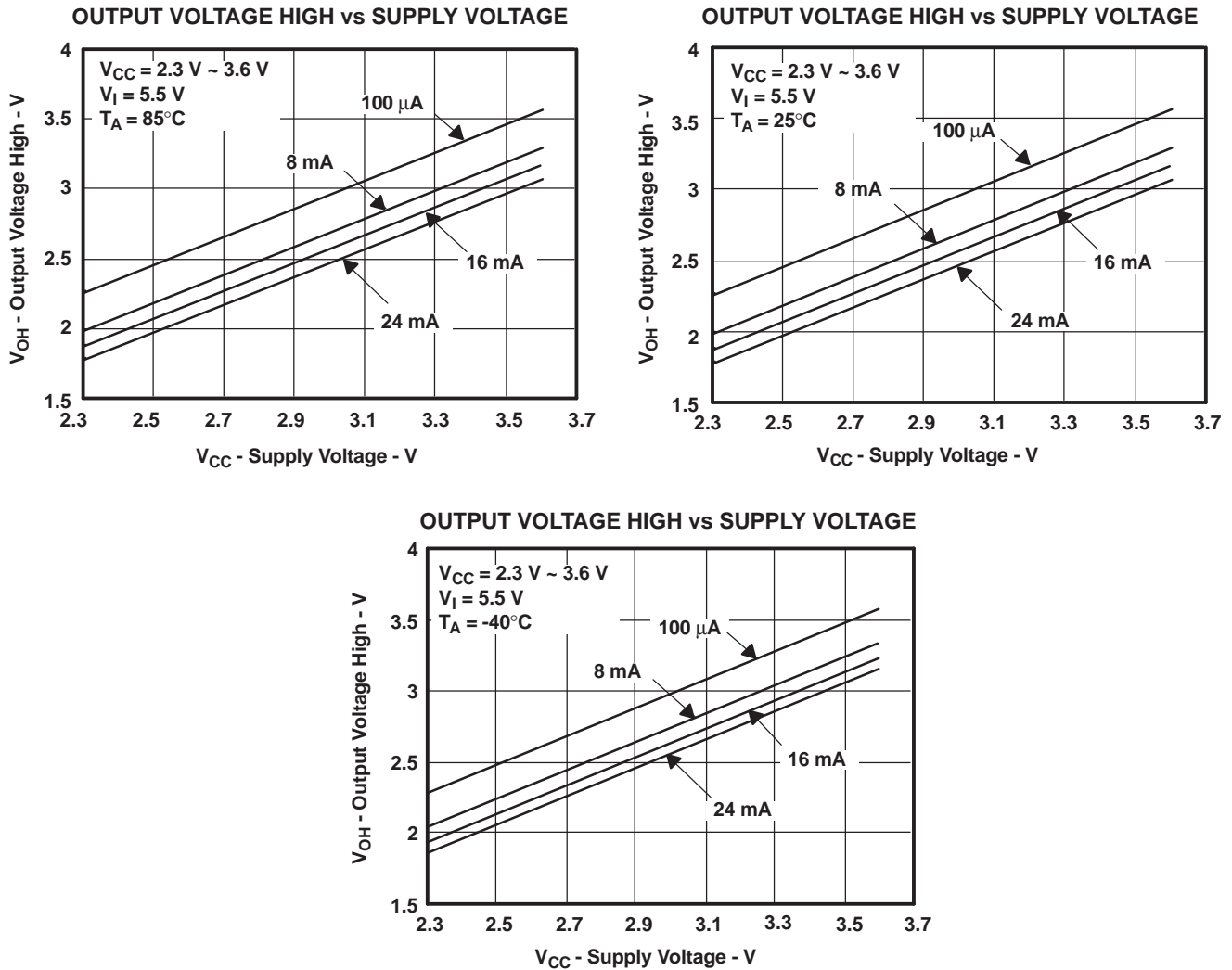

Figure 4. VOH Values

## REVISION HISTORY

### Changes from Revision A (March 2005) to Revision B

Page

- 
- Updated graphic note and picture in figure 1. .... [2](#)
-

**PACKAGING INFORMATION**

Orderable part number	Status (1)	Material type (2)	Package   Pins	Package qty   Carrier	RoHS (3)	Lead finish/ Ball material (4)	MSL rating/ Peak reflow (5)	Op temp (°C)	Part marking (6)
<a href="#">SN74CB3T16210DGGR</a>	Active	Production	TSSOP (DGG)   48	2000   LARGE T&R	Yes	NIPDAU	Level-1-260C-UNLIM	-40 to 85	CB3T16210
SN74CB3T16210DGGR.B	Active	Production	TSSOP (DGG)   48	2000   LARGE T&R	Yes	NIPDAU	Level-1-260C-UNLIM	-40 to 85	CB3T16210
<a href="#">SN74CB3T16210DGVR</a>	Active	Production	TVSOP (DGV)   48	2000   LARGE T&R	Yes	NIPDAU	Level-1-260C-UNLIM	-40 to 85	KR210
SN74CB3T16210DGVR.B	Active	Production	TVSOP (DGV)   48	2000   LARGE T&R	Yes	NIPDAU	Level-1-260C-UNLIM	-40 to 85	KR210
SN74CB3T16210DL	Preview	Production	SSOP (DL)   48	25   TUBE	-	Call TI	Call TI	-40 to 85	
SN74CB3T16210DLR	Preview	Production	SSOP (DL)   48	1000   LARGE T&R	-	Call TI	Call TI	-40 to 85	

<sup>(1)</sup> **Status:** For more details on status, see our [product life cycle](#).

<sup>(2)</sup> **Material type:** When designated, preproduction parts are prototypes/experimental devices, and are not yet approved or released for full production. Testing and final process, including without limitation quality assurance, reliability performance testing, and/or process qualification, may not yet be complete, and this item is subject to further changes or possible discontinuation. If available for ordering, purchases will be subject to an additional waiver at checkout, and are intended for early internal evaluation purposes only. These items are sold without warranties of any kind.

<sup>(3)</sup> **RoHS values:** Yes, No, RoHS Exempt. See the [TI RoHS Statement](#) for additional information and value definition.

<sup>(4)</sup> **Lead finish/Ball material:** Parts may have multiple material finish options. Finish options are separated by a vertical ruled line. Lead finish/Ball material values may wrap to two lines if the finish value exceeds the maximum column width.

<sup>(5)</sup> **MSL rating/Peak reflow:** The moisture sensitivity level ratings and peak solder (reflow) temperatures. In the event that a part has multiple moisture sensitivity ratings, only the lowest level per JEDEC standards is shown. Refer to the shipping label for the actual reflow temperature that will be used to mount the part to the printed circuit board.

<sup>(6)</sup> **Part marking:** There may be an additional marking, which relates to the logo, the lot trace code information, or the environmental category of the part.

Multiple part markings will be inside parentheses. Only one part marking contained in parentheses and separated by a "~" will appear on a part. If a line is indented then it is a continuation of the previous line and the two combined represent the entire part marking for that device.

**Important Information and Disclaimer:** The information provided on this page represents TI's knowledge and belief as of the date that it is provided. TI bases its knowledge and belief on information provided by third parties, and makes no representation or warranty as to the accuracy of such information. Efforts are underway to better integrate information from third parties. TI has taken and continues to take reasonable steps to provide representative and accurate information but may not have conducted destructive testing or chemical analysis on incoming materials and chemicals. TI and TI suppliers consider certain information to be proprietary, and thus CAS numbers and other limited information may not be available for release.

In no event shall TI's liability arising out of such information exceed the total purchase price of the TI part(s) at issue in this document sold by TI to Customer on an annual basis.

**OTHER QUALIFIED VERSIONS OF SN74CB3T16210 :**

- Automotive : [SN74CB3T16210-Q1](#)

## NOTE: Qualified Version Definitions:

- Automotive - Q100 devices qualified for high-reliability automotive applications targeting zero defects

**TAPE AND REEL INFORMATION**

**QUADRANT ASSIGNMENTS FOR PIN 1 ORIENTATION IN TAPE**

\*All dimensions are nominal

Device	Package Type	Package Drawing	Pins	SPQ	Reel Diameter (mm)	Reel Width W1 (mm)	A0 (mm)	B0 (mm)	K0 (mm)	P1 (mm)	W (mm)	Pin1 Quadrant
SN74CB3T16210DGGR	TSSOP	DGG	48	2000	330.0	24.4	8.6	13.0	1.8	12.0	24.0	Q1
SN74CB3T16210DGVR	TVSOP	DGV	48	2000	330.0	16.4	7.1	10.2	1.6	12.0	16.0	Q1

**TAPE AND REEL BOX DIMENSIONS**

\*All dimensions are nominal

Device	Package Type	Package Drawing	Pins	SPQ	Length (mm)	Width (mm)	Height (mm)
SN74CB3T16210DGGR	TSSOP	DGG	48	2000	356.0	356.0	45.0
SN74CB3T16210DGVR	TVSOP	DGV	48	2000	353.0	353.0	32.0

DGV (R-PDSO-G\*\*)

PLASTIC SMALL-OUTLINE

24 PINS SHOWN



4073251/E 08/00

- NOTES: A. All linear dimensions are in millimeters.  
 B. This drawing is subject to change without notice.  
 C. Body dimensions do not include mold flash or protrusion, not to exceed 0,15 per side.  
 D. Falls within JEDEC: 24/48 Pins – MO-153  
 14/16/20/56 Pins – MO-194

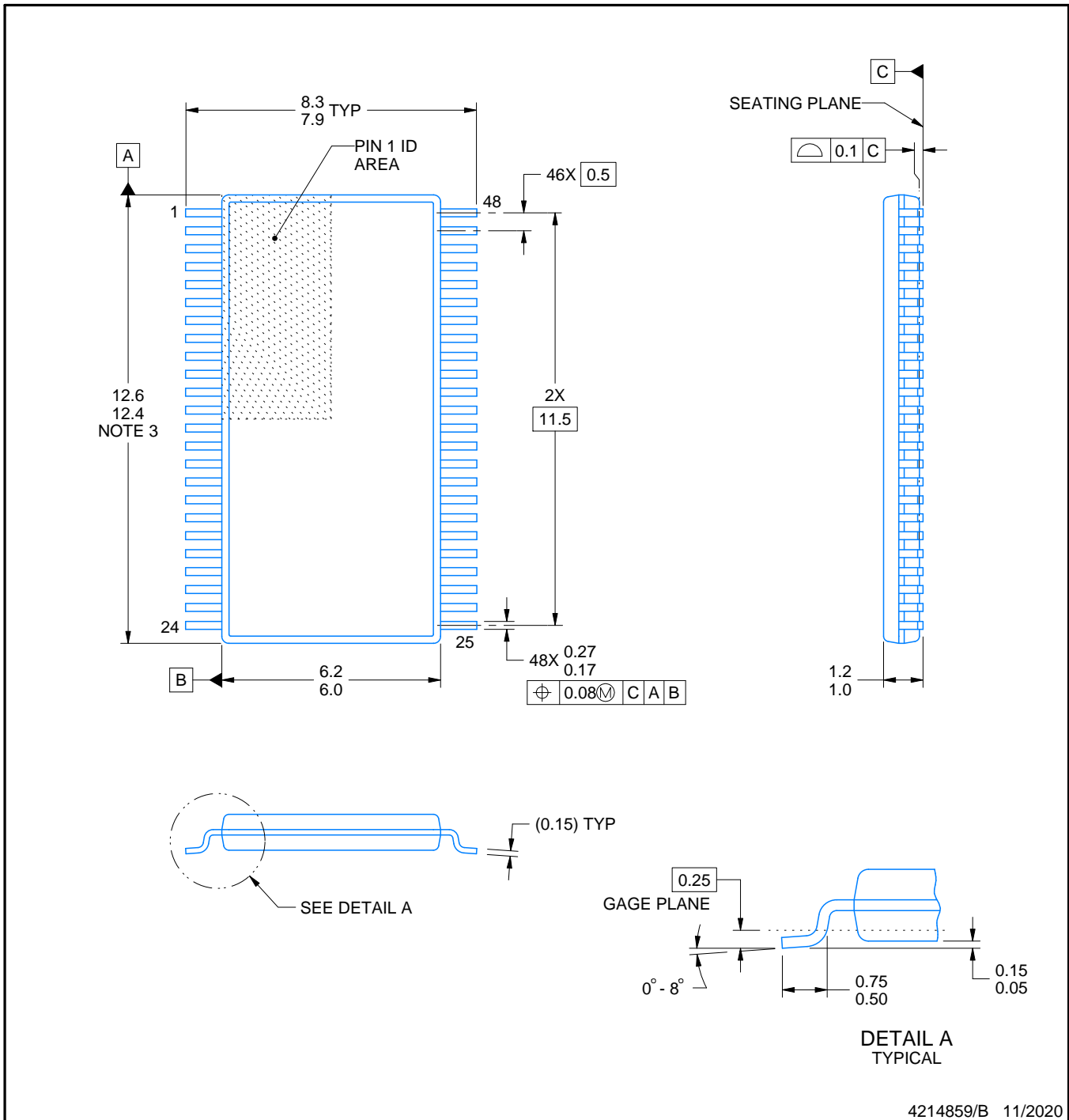
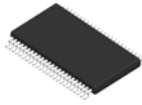

4214859/B 11/2020

NOTES:

1. All linear dimensions are in millimeters. Any dimensions in parenthesis are for reference only. Dimensioning and tolerancing per ASME Y14.5M.
2. This drawing is subject to change without notice.
3. This dimension does not include mold flash, protrusions, or gate burrs. Mold flash, protrusions, or gate burrs shall not exceed 0.15 mm per side.
4. Reference JEDEC registration MO-153.

# EXAMPLE BOARD LAYOUT

DGG0048A

TSSOP - 1.2 mm max height

SMALL OUTLINE PACKAGE

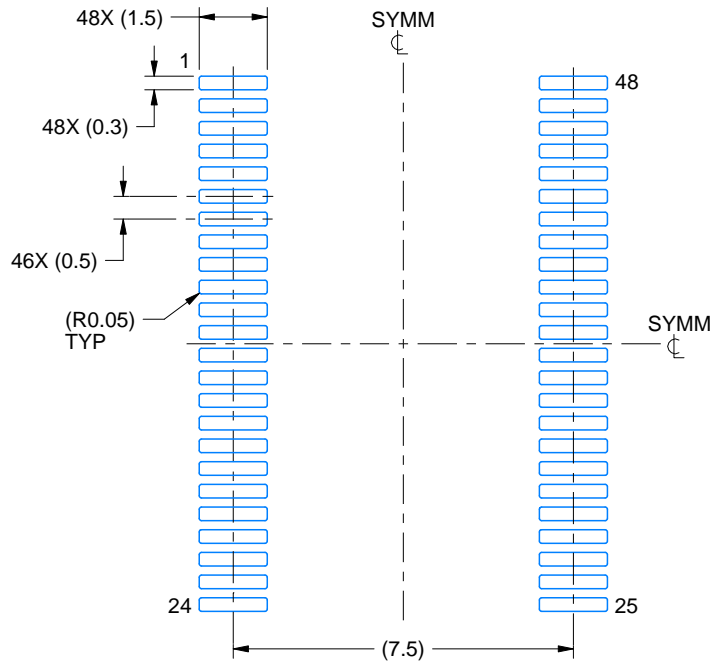

LAND PATTERN EXAMPLE  
SCALE:6X

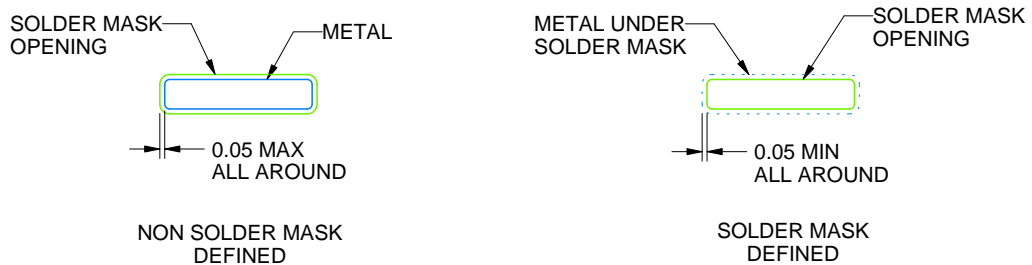

SOLDER MASK DETAILS

4214859/B 11/2020

NOTES: (continued)

5. Publication IPC-7351 may have alternate designs.
6. Solder mask tolerances between and around signal pads can vary based on board fabrication site.

# EXAMPLE STENCIL DESIGN

DGG0048A

TSSOP - 1.2 mm max height

SMALL OUTLINE PACKAGE

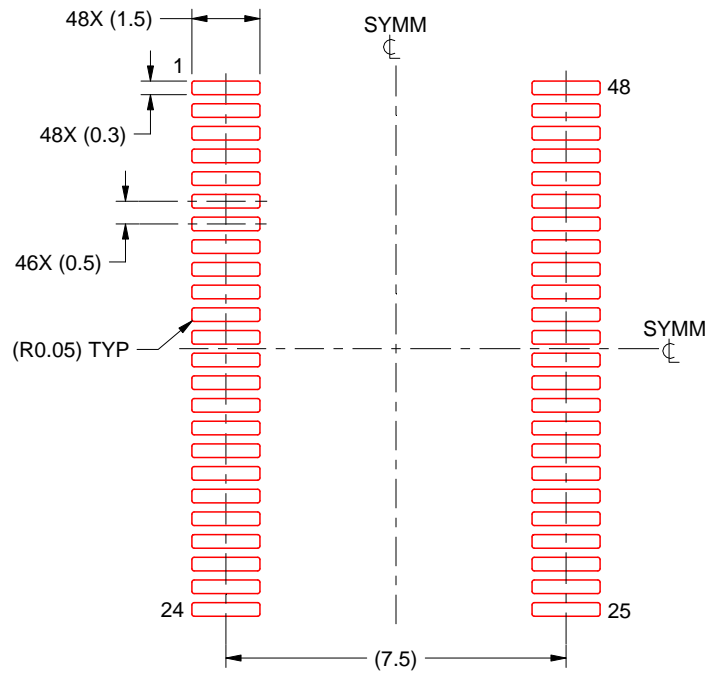

SOLDER PASTE EXAMPLE  
BASED ON 0.125 mm THICK STENCIL  
SCALE:6X

4214859/B 11/2020

NOTES: (continued)

7. Laser cutting apertures with trapezoidal walls and rounded corners may offer better paste release. IPC-7525 may have alternate design recommendations.
8. Board assembly site may have different recommendations for stencil design.

DGG (R-PDSO-G\*\*)

PLASTIC SMALL-OUTLINE PACKAGE

48 PINS SHOWN

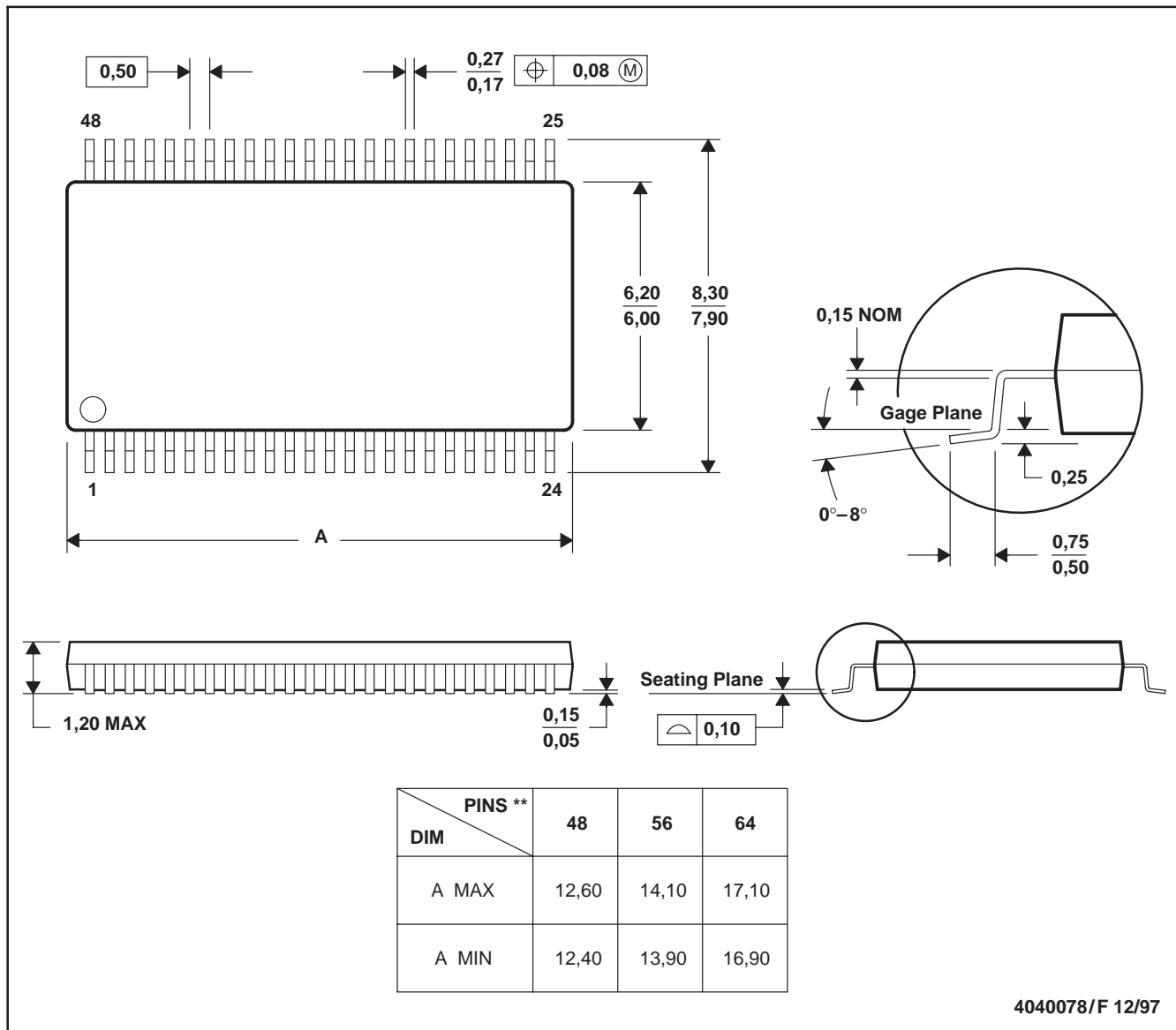

- NOTES: A. All linear dimensions are in millimeters.  
 B. This drawing is subject to change without notice.  
 C. Body dimensions do not include mold protrusion not to exceed 0,15.  
 D. Falls within JEDEC MO-153

## IMPORTANT NOTICE AND DISCLAIMER

TI PROVIDES TECHNICAL AND RELIABILITY DATA (INCLUDING DATASHEETS), DESIGN RESOURCES (INCLUDING REFERENCE DESIGNS), APPLICATION OR OTHER DESIGN ADVICE, WEB TOOLS, SAFETY INFORMATION, AND OTHER RESOURCES "AS IS" AND WITH ALL FAULTS, AND DISCLAIMS ALL WARRANTIES, EXPRESS AND IMPLIED, INCLUDING WITHOUT LIMITATION ANY IMPLIED WARRANTIES OF MERCHANTABILITY, FITNESS FOR A PARTICULAR PURPOSE OR NON-INFRINGEMENT OF THIRD PARTY INTELLECTUAL PROPERTY RIGHTS.

These resources are intended for skilled developers designing with TI products. You are solely responsible for (1) selecting the appropriate TI products for your application, (2) designing, validating and testing your application, and (3) ensuring your application meets applicable standards, and any other safety, security, regulatory or other requirements.

These resources are subject to change without notice. TI grants you permission to use these resources only for development of an application that uses the TI products described in the resource. Other reproduction and display of these resources is prohibited. No license is granted to any other TI intellectual property right or to any third party intellectual property right. TI disclaims responsibility for, and you fully indemnify TI and its representatives against any claims, damages, costs, losses, and liabilities arising out of your use of these resources.

TI's products are provided subject to [TI's Terms of Sale](#), [TI's General Quality Guidelines](#), or other applicable terms available either on [ti.com](#) or provided in conjunction with such TI products. TI's provision of these resources does not expand or otherwise alter TI's applicable warranties or warranty disclaimers for TI products. Unless TI explicitly designates a product as custom or customer-specified, TI products are standard, catalog, general purpose devices.

TI objects to and rejects any additional or different terms you may propose.

Copyright © 2025, Texas Instruments Incorporated

Last updated 10/2025

## Looking for pricing, stock, or lifecycle information?

Click below to explore more details on WIN SOURCE:

 [View SN74HC04ANS](#) on WIN SOURCE

 [Texas Instruments](#) Information

## Optimize Your Supply Chain with WIN SOURCE Solutions

-  Global Sourcing Solution
-  Obsolete Management
-  Cost Control Management
-  Shortage Management
-  Alternative Solution
-  Excess Inventory Management