



**THE DATASHEET OF
TPM27224-S01R**



TPS22995H-Q1 5.5-V, 3-A, 19-mΩ On-Resistance Automotive Load Switch

1 Features

- AEC-Q100 qualified for automotive applications:
 - Temperature grade 1: -40°C to 125°C , T_A
- Input operating voltage range (V_{IN}): 0.8 V–5.5 V
- Bias voltage supply (V_{BIAS}): 1.5 V–5.5 V
- Maximum continuous current: 3 A
- ON-resistance (R_{ON}): 19 mΩ (typ.)
- Adjustable slew rate control through external resistor
- Quick Output Discharge (QOD): 100 Ω (typ.)
- Thermal shutdown
- Humidity resistant pins:
 - 100-kΩ short to GND
 - 100-kΩ short to power
- Smart ON pin pulldown ($R_{PD,ON}$):
 - $ON \geq V_{IH}$ (I_{ON}): 25 nA (max.)
 - $ON \leq V_{IL}$ ($R_{PD,ON}$): 500 kΩ (typ.)
- Low power consumption:
 - ON state (I_Q): 10 μA (typ.)
 - OFF state (I_{SD}): 0.1 μA (typ.)

2 Applications

- [Infotainment](#)
- [Cluster](#)
- [ADAS](#)

3 Description

The TPS22995H-Q1 is a single-channel load switch that contains a 19-mΩ N-channel MOSFET that can operate over an input voltage range of 0.8 V to 5.5 V and can support a maximum continuous current of 3 A.

The switch is controlled by an on and off input (ON), which is capable of interfacing directly with low voltage GPIO signals. The TPS22995H-Q1 has a Quick Output Discharge when switch is turned off, pulling the output voltage down to a known 0-V state. Additionally, the device provides an adjustable rise to limit inrush currents with high capacitive loads.

The pins of the TPS22995H-Q1 are resistant to high humidity conditions, meaning that the device is able to function with a 100-kΩ short from any pin to GND or power. When the timing pin (RT) is affected by high humidity, timing is expected to stay within $\pm 20\%$.

The TPS22995H-Q1 is available in a 2.8-mm × 2.9-mm, 0.5-mm pitch, 6-pin SOT package. The device is characterized for operation over the free-air temperature range of -40°C to $+125^{\circ}\text{C}$.

Package Information

PART NUMBER	PACKAGE ⁽¹⁾	BODY SIZE (NOM)
TPS22995H-Q1	SOT-23 (DDC, 6)	2.80 mm × 2.90 mm

- (1) For all available packages, see the orderable addendum at the end of the data sheet.

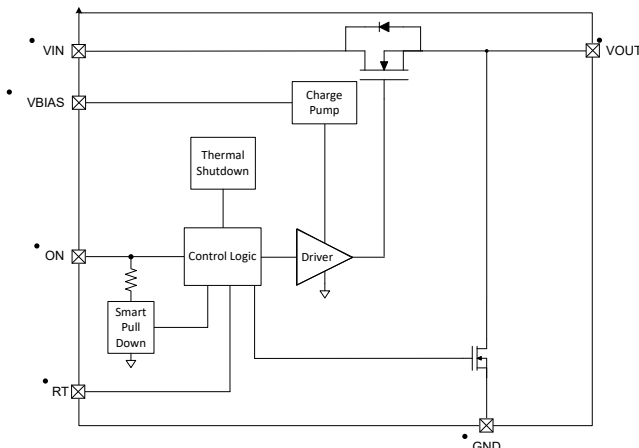

Block Diagram

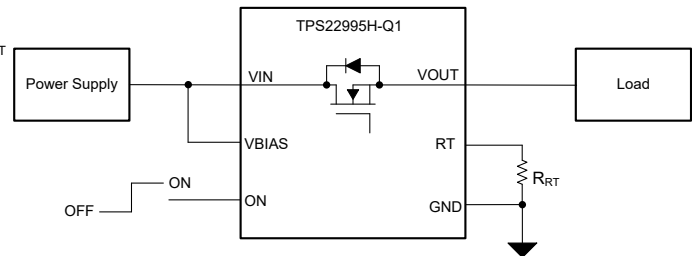

Typical Application Diagram



Table of Contents

1 Features	1	8.1 Overview.....	11
2 Applications	1	8.2 Functional Block Diagram.....	11
3 Description	1	8.3 Feature Description.....	11
4 Revision History	2	8.4 Device Functional Modes.....	12
5 Pin Configuration and Functions	3	9 Application and Implementation	13
6 Specifications	4	9.1 Application Information.....	13
6.1 Absolute Maximum Ratings.....	4	9.2 Typical Application.....	13
6.2 ESD Ratings.....	4	9.3 Power Supply Recommendations.....	14
6.3 Recommended Operating Conditions.....	4	9.4 Layout.....	14
6.4 Thermal Information.....	4	10 Device and Documentation Support	16
6.5 Electrical Characteristics (VBIAS = 5 V).....	5	10.1 Receiving Notification of Documentation Updates..	16
6.6 Electrical Characteristics (VBIAS = 3.3 V).....	5	10.2 Support Resources.....	16
6.7 Electrical Characteristics (VBIAS = 1.5 V).....	6	10.3 Trademarks.....	16
6.8 Switching Characteristics.....	7	10.4 Electrostatic Discharge Caution.....	16
6.9 Typical Characteristics.....	9	10.5 Glossary.....	16
7 Parameter Measurement Information	10	11 Mechanical, Packaging, and Orderable Information	16
8 Detailed Description	11		

4 Revision History

NOTE: Page numbers for previous revisions may differ from page numbers in the current version.

Changes from Revision * (June 2022) to Revision A (December 2022)	Page
• Changed device status from <i>Advance Information</i> to <i>Production Data</i>	1

5 Pin Configuration and Functions

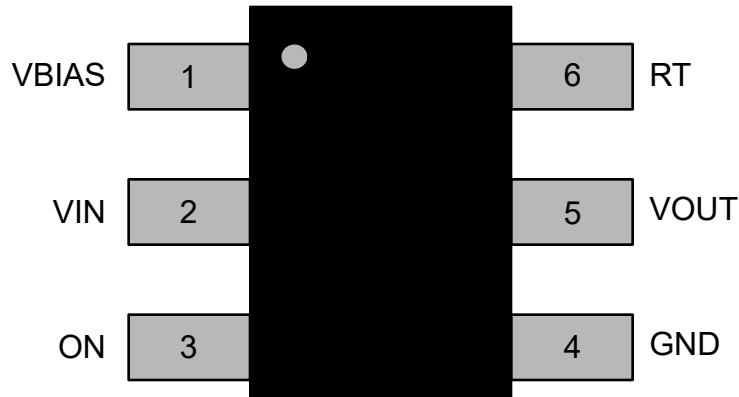

Figure 5-1. TPS22995H-Q1 DDC Package 6-Pin SOT-23 (Top View)

Table 5-1. Pin Functions

PIN		TYPE ⁽¹⁾	DESCRIPTION
NAME	NO.		
VBIAS	1	P	Device bias supply
VIN	2	P	Switch input
ON	3	O	Enable pin to turn on/off the switch
GND	4	G	Device ground
VOUT	5	P	Switch output
RT	6	I	Slew rate control through a resistor to GND

(1) I = Input, O = Output, I/O = Input or Output, G = Ground, P = Power.

6 Specifications

6.1 Absolute Maximum Ratings

over operating free-air temperature range (unless otherwise noted)⁽¹⁾

		MIN	MAX	UNIT
V _{IN}	Input Voltage	-0.3	6	V
V _{BIAS}	Bias Voltage	-0.3	6	V
V _{ON} , V _{RT}	Control Pin Voltage	-0.3	6	V
I _{MAX}	Maximum Current		3	A
T _J	Junction temperature		Internally Limited	°C
T _{stg}	Storage temperature	-65	150	°C

- (1) Operation outside the Absolute Maximum Ratings may cause permanent device damage. Absolute Maximum Ratings do not imply functional operation of the device at these or any other conditions beyond those listed under Recommended Operating Conditions. If used outside the Recommended Operating Conditions but within the Absolute Maximum Ratings, the device may not be fully functional, and this may affect device reliability, functionality, performance, and shorten the device lifetime.

6.2 ESD Ratings

			VALUE	UNIT
V _(ESD)	Electrostatic discharge	Human-body model (HBM), per AEC Q100-002 ⁽¹⁾ HBM ESD classification level 1C	±2000	V
		Charged-device model (CDM), per AEC Q100-011 CDM ESD classification level C5	±1000	

- (1) AEC Q100-002 indicates that HBM stressing shall be in accordance with the ANSI/ESDA/JEDEC JS-001 specification.

6.3 Recommended Operating Conditions

over operating free-air temperature range (unless otherwise noted)

		MIN	NOM	MAX	UNIT
V _{IN}	Input Voltage	0.8		5.5	V
V _{BIAS}	Bias Voltage	1.5		5.5	V
V _{IH}	ON Pin High Voltage Range	0.8		5.5	V
V _{IL}	ON Pin Low Voltage Range	0		0.35	V
T _A	Ambient Temperature	-40		125	°C

6.4 Thermal Information

THERMAL METRIC ⁽¹⁾		TPS22995H-Q1		UNIT
		DDC		
		6 PINS		
R _{θJA}	Junction-to-ambient thermal resistance	120.6		°C/W
R _{θJC(top)}	Junction-to-case (top) thermal resistance	65.5		°C/W
R _{θJB}	Junction-to-board thermal resistance	33.9		°C/W
Ψ _{JT}	Junction-to-top characterization parameter	17.2		°C/W
Y _{JB}	Junction-to-board characterization parameter	3.6		°C/W

- (1) For more information about traditional and new thermal metrics, see the [Semiconductor and IC Package Thermal Metrics](#) application report.

6.5 Electrical Characteristics (VBIAS = 5 V)

over operating free-air temperature range (unless otherwise noted)

PARAMETER		TEST CONDITIONS	T _A	MIN	TYP	MAX	UNIT
Power Consumption							
I _{SD,VBIAS}	VBIAS Shutdown Current	ON = 0V	25°C	0.1			µA
			-40°C to 85°C			0.5	µA
			-40°C to 125°C			2	µA
I _{Q,VBIAS}	VBIAS Quiescent Current	ON > V _{IH}	25°C	10			µA
			-40°C to 85°C			20	µA
			-40°C to 125°C			20	µA
I _{SD,VIN}	VIN Shutdown Current	ON = 0V	25°C	0.1			µA
			-40°C to 85°C			1	µA
			-40°C to 125°C			4	µA
I _{ON}	ON pin leakage	ON = VBIAS	-40°C to 125°C	0.1			µA
Performance							
R _{ON}	On-Resistance	VIN = 5 V, I _{OUT} = -200 mA	25°C	19			mΩ
			-40°C to 85°C			26	mΩ
			-40°C to 125°C			29	mΩ
			25°C	19			mΩ
			-40°C to 85°C			25	mΩ
			-40°C to 125°C			28	mΩ
		VIN = 3.3 V, I _{OUT} = -200 mA	25°C	19			mΩ
			-40°C to 85°C			25	mΩ
			-40°C to 125°C			28	mΩ
			25°C	19			mΩ
			-40°C to 85°C			25	mΩ
			-40°C to 125°C			28	mΩ
		VIN = 1.8 V, I _{OUT} = -200 mA	25°C	19			mΩ
			-40°C to 85°C			25	mΩ
			-40°C to 125°C			28	mΩ
			25°C	19			mΩ
			-40°C to 85°C			25	mΩ
			-40°C to 125°C			28	mΩ
VIN = 1.2 V, I _{OUT} = -200 mA	25°C	19			mΩ		
	-40°C to 85°C			25	mΩ		
	-40°C to 125°C			28	mΩ		
	25°C	19			mΩ		
	-40°C to 85°C			25	mΩ		
	-40°C to 125°C			28	mΩ		
VIN = 0.8 V, I _{OUT} = -200 mA	25°C	19			mΩ		
	-40°C to 85°C			25	mΩ		
	-40°C to 125°C			28	mΩ		
	25°C	19			mΩ		
	-40°C to 85°C			25	mΩ		
	-40°C to 125°C			28	mΩ		
R _{PD,ON}	Smart Pull Down Resistance	ON < V _{IL}	25°C	500			kΩ
			-40°C to 125°C			1000	kΩ
R _{QOD}	QOD Resistance	ON < V _{IL}	25°C	100			Ω
R _{QOD}			-40°C to 125°C			150	Ω
Protection							
TSD	Thermal Shutdown		-	150	170	190	°C
TSD _{HYS}	Thermal Shutdown Hysteresis		-	20			°C

6.6 Electrical Characteristics (VBIAS = 3.3 V)

over operating free-air temperature range (unless otherwise noted)

PARAMETER		TEST CONDITIONS	T _A	MIN	TYP	MAX	UNIT
Power Consumption							
I _{SD,VBIAS}	VBIAS Shutdown Current	ON = 0 V	25°C	0.1			µA
			-40°C to 85°C			0.5	µA
			-40°C to 125°C			2	µA

6.6 Electrical Characteristics (VBIAS = 3.3 V) (continued)

over operating free-air temperature range (unless otherwise noted)

PARAMETER		TEST CONDITIONS	T _A	MIN	TYP	MAX	UNIT
I _{Q,VBIAS}	VBIAS Quiescent Current	ON > V _{IH}	25°C		8.5		µA
			-40°C to 85°C			20	µA
			-40°C to 125°C			20	µA
I _{SD,VIN}	VIN Shutdown Current	ON = 0V	25°C		0.1		µA
			-40°C to 85°C			1	µA
			-40°C to 125°C			4	µA
I _{ON}	ON pin leakage	ON = VBIAS	-40°C to 125°C		0.1		µA
Performance							
R _{ON}	On-Resistance	VIN = 3.3 V, I _{O_{UT}} = -200 mA	25°C		19		mΩ
			-40°C to 85°C			26	mΩ
			-40°C to 125°C			29	mΩ
		VIN = 1.8 V, I _{O_{UT}} = -200 mA	25°C		19		mΩ
			-40°C to 85°C			25	mΩ
			-40°C to 125°C			28	mΩ
		VIN = 1.2 V, I _{O_{UT}} = -200 mA	25°C		19		mΩ
			-40°C to 85°C			25	mΩ
			-40°C to 125°C			28	mΩ
		VIN = 0.8 V, I _{O_{UT}} = -200 mA	25°C		19		mΩ
			-40°C to 85°C			25	mΩ
			-40°C to 125°C			28	mΩ
R _{PD,ON}	Smart Pull Down Resistance	ON < V _{IL}	25°C		500		kΩ
			-40°C to 125°C			1000	kΩ
R _{QOD}	QOD Resistance	ON < V _{IL}	25°C		100		Ω
			-40°C to 125°C			150	Ω
Protection							
TSD	Thermal Shutdown		-	150	170	190	°C
TSD _{HYS}	Thermal Shutdown Hysteresis		-		20		°C

6.7 Electrical Characteristics (VBIAS = 1.5 V)

over operating free-air temperature range (unless otherwise noted)

PARAMETER		TEST CONDITIONS	T _A	MIN	TYP	MAX	UNIT
Power Consumption							
I _{SD,VBIAS}	VBIAS Shutdown Current	ON = 0 V	25°C		0.1		µA
			-40°C to 85°C			0.5	µA
			-40°C to 125°C			2	µA
I _{Q,VBIAS}	VBIAS Quiescent Current	ON > V _{IH}	25°C		10		µA
			-40°C to 85°C			20	µA
			-40°C to 125°C			20	µA
I _{SD,VIN}	VIN Shutdown Current	ON = 0 V	25°C		0.1		µA
			-40°C to 85°C			1	µA
			-40°C to 125°C			4	µA
I _{ON}	ON pin leakage	ON = VBIAS	-40°C to 125°C		0.1		µA
Performance							

6.7 Electrical Characteristics (VBIAS = 1.5 V) (continued)

over operating free-air temperature range (unless otherwise noted)

PARAMETER		TEST CONDITIONS	T _A	MIN	TYP	MAX	UNIT
R _{ON}	On-Resistance	VIN = 1.5 V, I _{OUT} = -200 mA	25°C		22		mΩ
			-40°C to 85°C			30	mΩ
			-40°C to 125°C			34	mΩ
		VIN = 1.2 V, I _{OUT} = -200 mA	25°C		22		mΩ
			-40°C to 85°C			30	mΩ
			-40°C to 125°C			34	mΩ
		VIN = 0.8 V, I _{OUT} = -200 mA	25°C		21		mΩ
			-40°C to 85°C			28	mΩ
			-40°C to 125°C			31	mΩ
R _{PD,ON}	Smart Pull Down Resistance	ON < V _{IL}	25°C		500		kΩ
			-40°C to 125°C			800	kΩ
R _{QOD}	QOD Resistance	ON < V _{IL}	25°C		100		Ω
			-40°C to 125°C			150	Ω
Protection							
TSD	Thermal Shutdown		-	150	170	190	°C
TSD _{HYS}	Thermal Shutdown Hysteresis		-		20		°C

6.8 Switching Characteristics

over operating free-air temperature range (unless otherwise noted)

PARAMETER		TEST CONDITIONS	MIN	TYP	MAX	UNIT
VIN = 5.5 V						
t _{ON}	Turn ON time	R _L = 100 Ω, C _L = 10 uF, RT = 1 kΩ		264		us
t _{RISE}	Rise time	R _L = 100 Ω, C _L = 10 uF, RT = 1 kΩ		129		us
t _D	Delay time	R _L = 100 Ω, C _L = 10 uF, RT = 1 kΩ		127		us
t _{FALL}	Fall time	R _L = 100 Ω, C _L = 10 uF, RT = 1 kΩ		1100		us
t _{OFF}	Turn OFF time	R _L = 100 Ω, C _L = 10 uF, RT = 1 kΩ		60.2		us
VIN = 5 V						
t _{ON}	Turn ON time	R _L = 100 Ω, C _L = 10 uF, RT = 1 kΩ		294		us
t _{RISE}	Rise time	R _L = 100 Ω, C _L = 10 uF, RT = 1 kΩ		166		us
t _D	Delay time	R _L = 100 Ω, C _L = 10 uF, RT = 1 kΩ		127		us
t _{FALL}	Fall time	R _L = 100 Ω, C _L = 10 uF, RT = 1 kΩ		1110		us
t _{OFF}	Turn OFF time	R _L = 100 Ω, C _L = 10 uF, RT = 1 kΩ		60.3		us
VIN = 3.3 V						
t _{ON}	Turn ON time	R _L = 100 Ω, C _L = 10 uF, RT = 1 kΩ		259		us
t _{RISE}	Rise time	R _L = 100 Ω, C _L = 10 uF, RT = 1 kΩ		129		us
t _D	Delay time	R _L = 100 Ω, C _L = 10 uF, RT = 1 kΩ		130		us
t _{FALL}	Fall time	R _L = 100 Ω, C _L = 10 uF, RT = 1 kΩ		1120		us
t _{OFF}	Turn OFF time	R _L = 100 Ω, C _L = 10 uF, RT = 1 kΩ		62		us
VIN = 1.8 V						
t _{ON}	Turn ON time	R _L = 100 Ω, C _L = 10 uF, RT = 1 kΩ		224		us
t _{RISE}	Rise time	R _L = 100 Ω, C _L = 10 uF, RT = 1 kΩ		89.1		us
t _D	Delay time	R _L = 100 Ω, C _L = 10 uF, RT = 1 kΩ		135		us
t _{FALL}	Fall time	R _L = 100 Ω, C _L = 10 uF, RT = 1 kΩ		1120		us
t _{OFF}	Turn OFF time	R _L = 100 Ω, C _L = 10 uF, RT = 1 kΩ		65.2		us

6.8 Switching Characteristics (continued)

over operating free-air temperature range (unless otherwise noted)

PARAMETER		TEST CONDITIONS	MIN	TYP	MAX	UNIT
VIN = 1.2 V						
tON	Turn ON time	$R_L = 100 \Omega$, $C_L = 10 \mu\text{F}$, $R_T = 1 \text{ k}\Omega$		208		us
tRISE	Rise time	$R_L = 100 \Omega$, $C_L = 10 \mu\text{F}$, $R_T = 1 \text{ k}\Omega$		68.6		us
tD	Delay time	$R_L = 100 \Omega$, $C_L = 10 \mu\text{F}$, $R_T = 1 \text{ k}\Omega$		140		us
tFALL	Fall time	$R_L = 100 \Omega$, $C_L = 10 \mu\text{F}$, $R_T = 1 \text{ k}\Omega$		1160		us
tOFF	Turn OFF time	$R_L = 100 \Omega$, $C_L = 10 \mu\text{F}$, $R_T = 1 \text{ k}\Omega$		66.7		us
VIN = 0.8 V						
tON	Turn ON time	$R_L = 100 \Omega$, $C_L = 10 \mu\text{F}$, $R_T = 1 \text{ k}\Omega$		197		us
tRISE	Rise time	$R_L = 100 \Omega$, $C_L = 10 \mu\text{F}$, $R_T = 1 \text{ k}\Omega$		53		us
tD	Delay time	$R_L = 100 \Omega$, $C_L = 10 \mu\text{F}$, $R_T = 1 \text{ k}\Omega$		144		us
tFALL	Fall time	$R_L = 100 \Omega$, $C_L = 10 \mu\text{F}$, $R_T = 1 \text{ k}\Omega$		1190		us
tOFF	Turn OFF time	$R_L = 100 \Omega$, $C_L = 10 \mu\text{F}$, $R_T = 1 \text{ k}\Omega$		69.5		us

6.9 Typical Characteristics

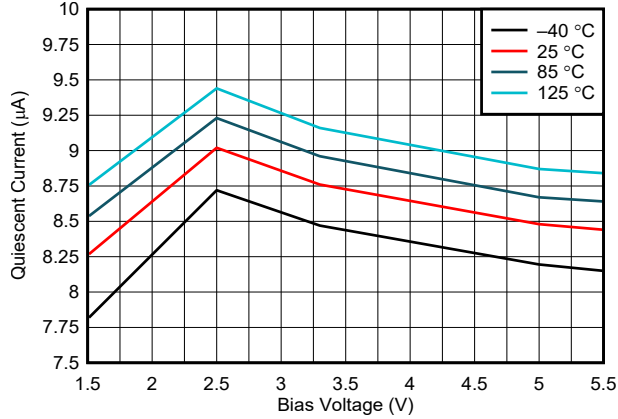

VIN = VBIAS

Figure 6-1. Quiescent Current vs Bias Voltage

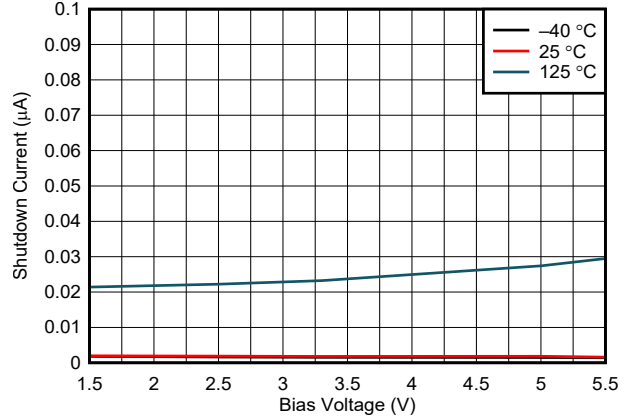

VIN = VBIAS

Figure 6-2. Shutdown Current vs Bias Voltage

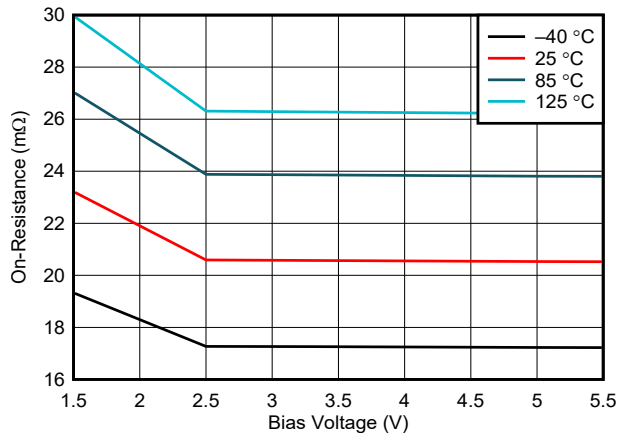

VIN = VBIAS

Figure 6-3. On-Resistance vs Bias Voltage

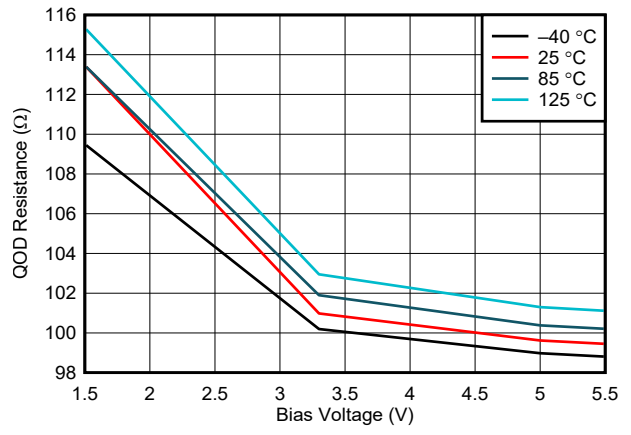

VIN = VBIAS

Figure 6-4. QOD Resistance vs Bias Voltage

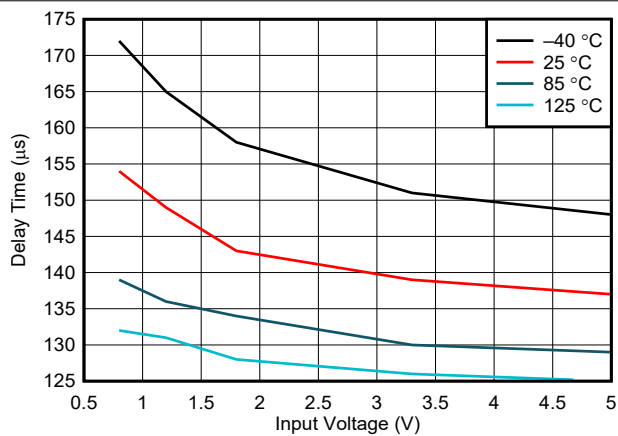

VIN = VBIAS

Figure 6-5. Delay Time vs Bias Voltage

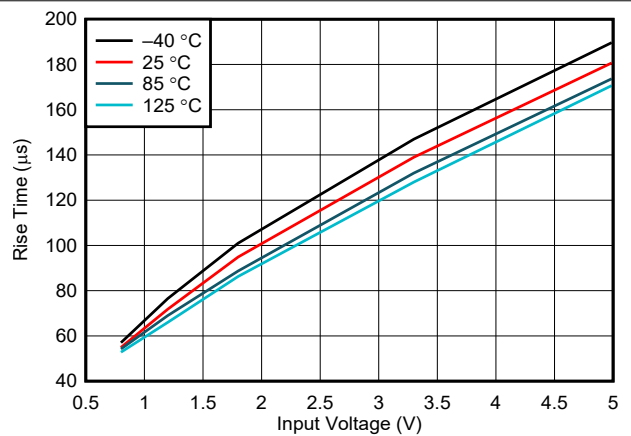

VIN = VBIAS

Figure 6-6. Rise Time vs Bias Voltage

7 Parameter Measurement Information

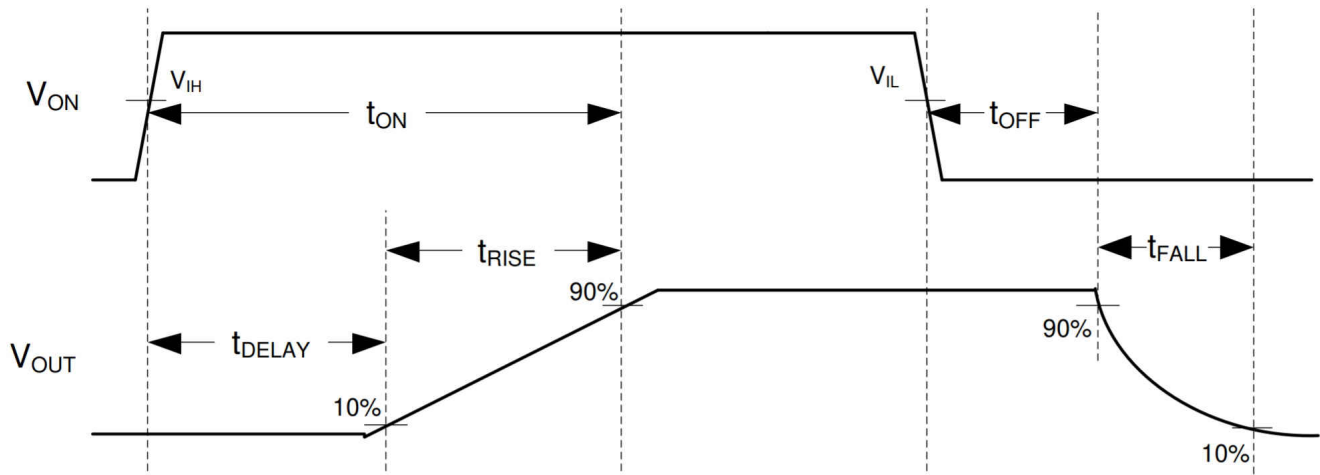

Figure 7-1. TPS22995H-Q1 Timing Parameters

8 Detailed Description

8.1 Overview

The TPS22995H-Q1 is a 5.5-V, 3-A load switch in a 6-pin SOT-23 package. To reduce voltage drop for low voltage and high-current rails, the device implements a low-resistance, 19-mΩ N-channel MOSFET, which reduces the drop-out voltage through the device.

The device has a configurable slew rate, which helps reduce or eliminate power supply droop because of large inrush currents. The slew rate can be configured by connecting a resistor to ground to the RT pin. The TPS22995H-Q1 also integrates a Quick Output Discharge circuit that is activated when the switch is turned off, pulling the output voltage down to a known 0-V state.

TPS22995H-Q1 increases circuit robustness by integrating tolerance to high humidity environments. When the timing pin (RT) is affected by high humidity, timing is expected to stay within $\pm 20\%$. Additionally, if the device experiences a 100-kΩ short from any pin to GND or power, the device continues to function.

8.2 Functional Block Diagram

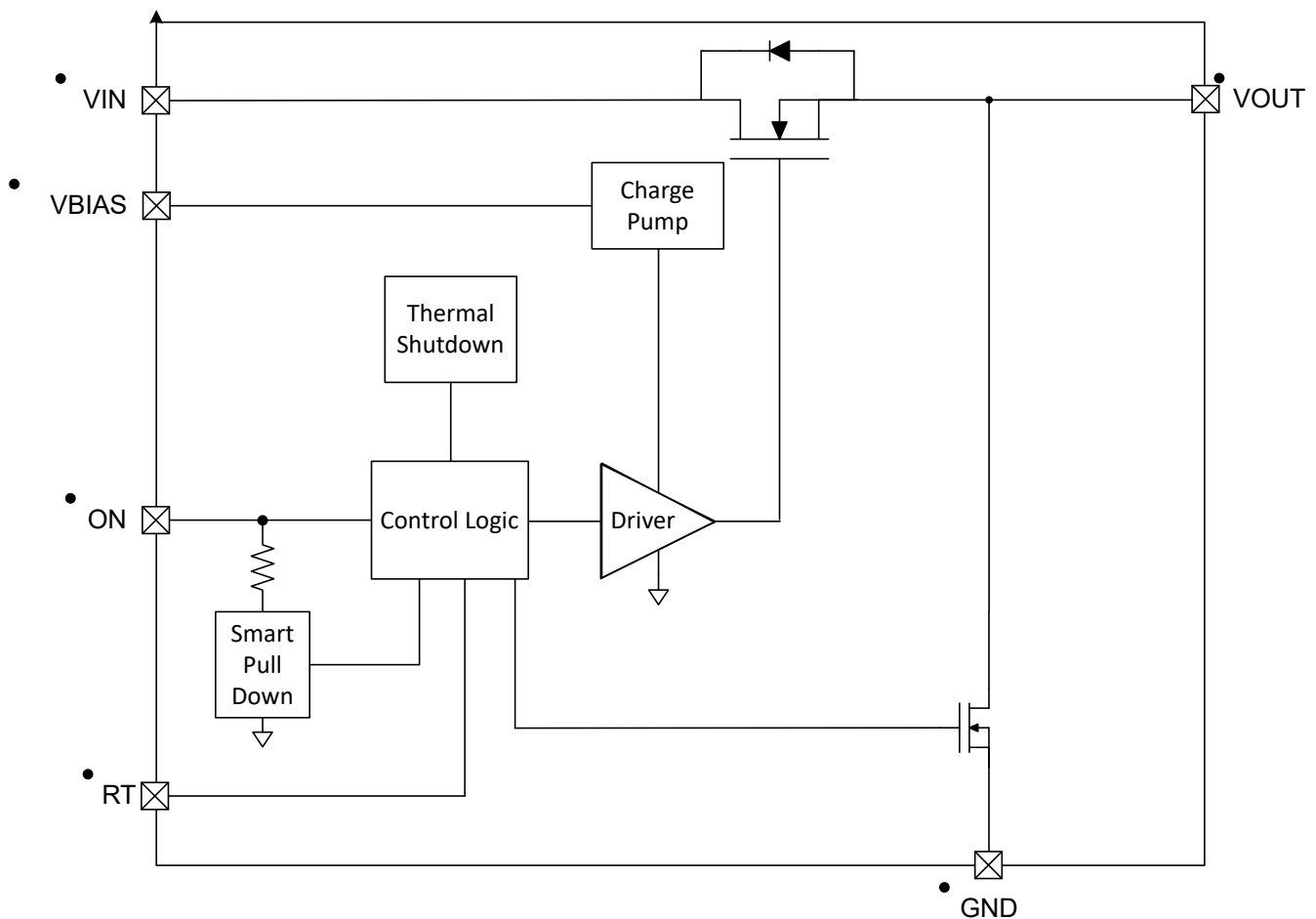

8.3 Feature Description

8.3.1 ON and OFF Control

The ON pin controls the state of the switch. The ON pin is compatible with standard GPIO logic threshold so it can be used in a wide variety of applications. When power is first applied to VIN, a Smart Pulldown is used to keep the ON pin from floating until the system sequencing is complete. After the ON pin is deliberately driven high ($\geq V_{IH}$), the Smart Pulldown is disconnected to prevent unnecessary power loss. See the below table when the ON Pin Smart Pulldown is active.

Table 8-1. On Pin Control

ON Pin Voltage	ON Pin Function
$\leq V_{IL}$	Pulldown active
$\geq V_{IH}$	No Pulldown

8.3.2 Quick Output Discharge (QOD)

TPS22995H-Q1 integrates Quick Output Discharge. When the switch is disabled, a discharge resistor is connected between VOUT and GND. This resistor has a typical value of 100 Ω and prevents the output from floating while the switch is disabled

8.3.3 Adjustable Slew Rate

A resistor to GND on the RT pin sets the slew rate, and the higher the resistor the lower the slew rate. Rise times are shown below.

Table 8-2. Rise Time vs RT vs V_{IN}

RT Resistor	$V_{IN} = 5\text{ V}$	$V_{IN} = 3.3\text{ V}$	$V_{IN} = 1.8\text{ V}$	$V_{IN} = 1.2\text{ V}$	$V_{IN} = 0.8\text{ V}$
GND	102 μs	79 μs	55 μs	42 μs	33 μs
1 k Ω	166 μs	129 μs	89 μs	68 μs	53 μs
5 k Ω	790 μs	607 μs	415 μs	318 μs	242 μs
10 k Ω	1520 μs	1180 μs	800 μs	613 μs	465 μs
Open	4860 μs	3750 μs	2560 μs	1960 μs	1490 μs

The following equation can be used to estimate the rise time for different V_{IN} and RT resistors:

$$tR = (0.0246 V_{IN} + 0.0308) \times RT + 3.3219 V_{IN} + 6.7312$$

where

- tR = Rise time in μs .
- V_{IN} = Input voltage in V.
- RT = RT Resistor in Ω .

8.3.4 Thermal Shutdown

When the device temperature reaches 170°C (typical), the device shuts itself off to prevent thermal damage. After the device cools off by about 20°C, it turns back on. If the device is kept in a thermally stressful environment, then the device oscillates between these two states until it can keep its temperature below the thermal shutdown point.

8.4 Device Functional Modes

Table 8-3. Device Functional Modes

ON	Fault Condition	VOUT State
L	N/A	Hi-Z
H	None	V_{IN} through R_{ON}
X	Thermal shutdown	Hi-Z

9 Application and Implementation

Note

Information in the following applications sections is not part of the TI component specification, and TI does not warrant its accuracy or completeness. TI's customers are responsible for determining suitability of components for their purposes, as well as validating and testing their design implementation to confirm system functionality.

9.1 Application Information

The input to output voltage drop in the device is determined by the R_{ON} of the device and the load current. The R_{ON} of the device depends upon the V_{IN} and V_{BIAS} condition of the device. See the R_{ON} specification in the [Electrical Characteristics \(\$V_{BIAS} = 5\text{ V}\$ \)](#) table of this data sheet. After the R_{ON} of the device is determined based upon the V_{IN} and V_{BIAS} conditions, use the below equation to calculate the input to output voltage drop.

$$\Delta V = I_{LOAD} \times R_{ON} \quad (1)$$

where

- ΔV is the voltage drop from V_{IN} to V_{OUT} .
- I_{LOAD} is the load current.
- R_{ON} is the on-resistance of the device for a specific V_{IN} and V_{BIAS} .
- An appropriate I_{LOAD} must be chosen such that the I_{MAX} specification of the device is not violated.

9.2 Typical Application

This typical application demonstrates how the TPS22995H-Q1 device can be used to limit start-up inrush current.

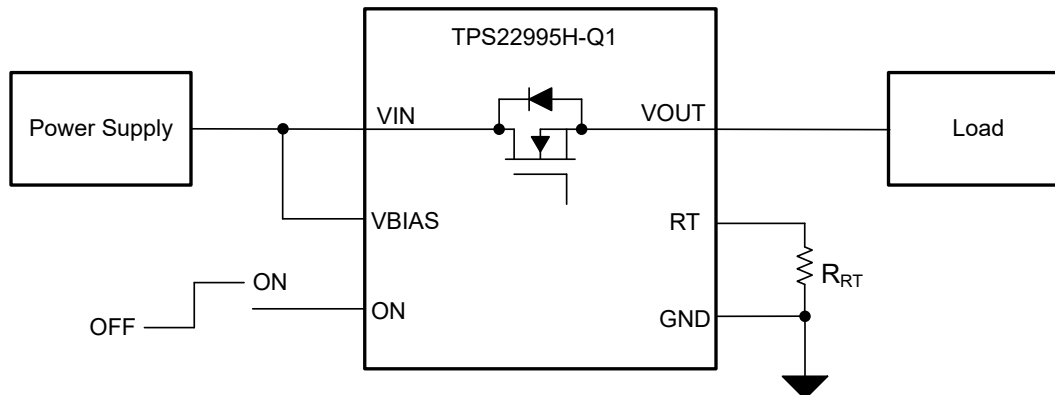

Figure 9-1. TPS22995H-Q1 Application Schematic

9.2.1 Design Requirements

Table 9-1. Design Parameters

DESIGN PARAMETER	EXAMPLE VALUE
V_{BIAS}	5.0 V
V_{IN}	5.0 V
C_L	47 μF
R_L	None
Maximum acceptable inrush current	200 mA

9.2.2 Detailed Design Procedure

When the switch is enabled, the output capacitors must be charged up from 0 V to V_{IN} . This charge arrives in the form of inrush current. Use the equation below to calculate inrush current.

$$I_{INRUSH} = C_L \times dVOUT/dt \quad (2)$$

where

- C_L is the output capacitance.
- $dVOUT$ is the change in $VOUT$ during the ramp up of the output voltage when device is enabled.
- dt is the rise time in $VOUT$ during the ramp up of the output voltage when the device is enabled.

The TPS22995H-Q1 offers an adjustable rise time for $VOUT$, allowing the user to control the inrush current during turn-on. The appropriate rise time can be calculated using the design requirements and the inrush current equation as shown below.

$$200 \text{ mA} = 47\mu\text{F} \times 5 \text{ V}/dt \quad (3)$$

where

$$dt = 1175 \text{ us} \quad (4)$$

The TPS22995H-Q1 has very fast rise times with RT pin grounded. The typical rise time is 147 μs at $V_{BIAS} = 5\text{V}$, $V_{IN} = 5 \text{ V}$, $R_L = 100 \Omega$, and $C_L = 0.1 \mu\text{F}$. This rise time results in an inrush current of 1.59 A. According to the rise time [table](#), using $R_T = 10 \text{ k}\Omega$ results in a rise time of 1520 us, which limits the inrush current to 154 mA. Alternatively, the [rise time equation](#) can be used to determine the resistor need.

9.3 Power Supply Recommendations

The TPS22995H-Q1 device is designed to operate with a V_{IN} range of 0.8 V to 5.5 V. The V_{IN} power supply must be well regulated and placed as close to the device terminal as possible. The power supply must be able to withstand all transient load current steps. In most situations, using an input capacitance (C_{IN}) of 1 μF is sufficient to prevent the supply voltage from dipping when the switch is turned on. In cases where the power supply is slow to respond to a large transient current or large load current step, additional bulk capacitance can be required on the input.

9.4 Layout

9.4.1 Layout Guidelines

For best performance, all traces must be as short as possible. To be most effective, the input and output capacitors must be placed close to the device to minimize the effects that parasitic trace inductances can have on normal operation. Using wide traces for V_{IN} , V_{OUT} , and GND helps minimize the parasitic electrical effects.

9.4.2 Layout Example

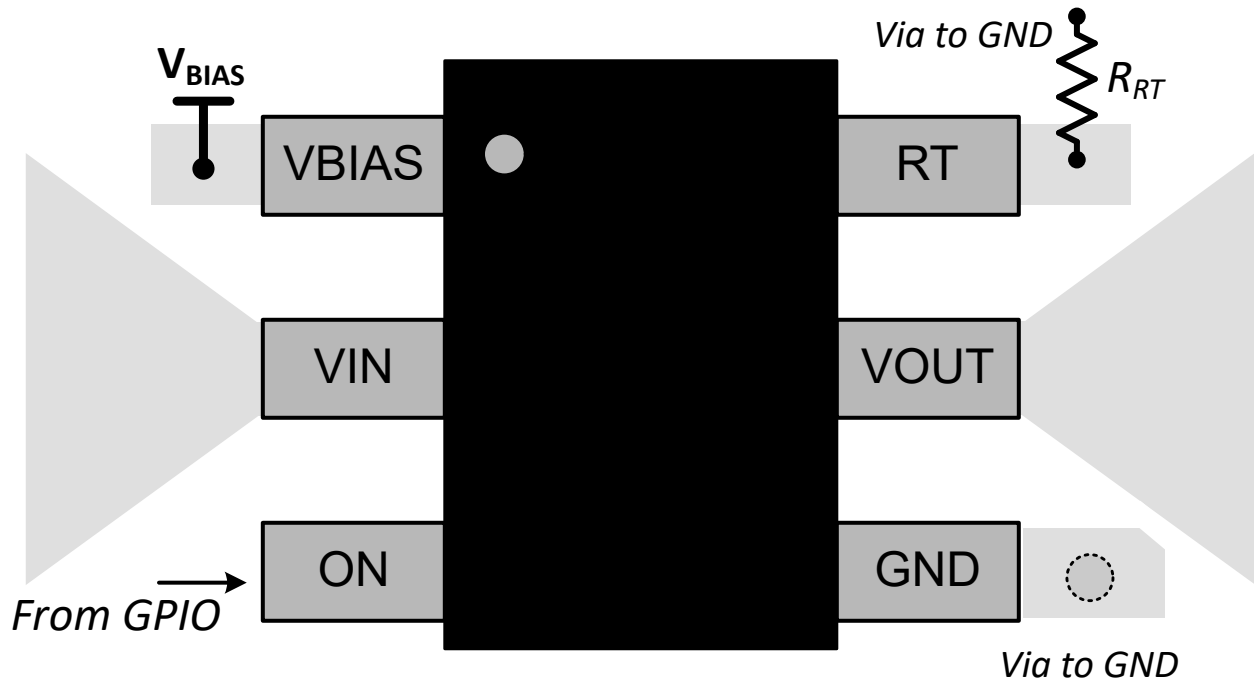

Figure 9-2. Layout Example (SOT)

10 Device and Documentation Support

TI offers an extensive line of development tools. Tools and software to evaluate the performance of the device, generate code, and develop solutions are listed below.

10.1 Receiving Notification of Documentation Updates

To receive notification of documentation updates, navigate to the device product folder on ti.com. Click on *Subscribe to updates* to register and receive a weekly digest of any product information that has changed. For change details, review the revision history included in any revised document.

10.2 Support Resources

[TI E2E™ support forums](#) are an engineer's go-to source for fast, verified answers and design help — straight from the experts. Search existing answers or ask your own question to get the quick design help you need.

Linked content is provided "AS IS" by the respective contributors. They do not constitute TI specifications and do not necessarily reflect TI's views; see TI's [Terms of Use](#).

10.3 Trademarks

TI E2E™ is a trademark of Texas Instruments.

All trademarks are the property of their respective owners.

10.4 Electrostatic Discharge Caution



This integrated circuit can be damaged by ESD. Texas Instruments recommends that all integrated circuits be handled with appropriate precautions. Failure to observe proper handling and installation procedures can cause damage.

ESD damage can range from subtle performance degradation to complete device failure. Precision integrated circuits may be more susceptible to damage because very small parametric changes could cause the device not to meet its published specifications.

10.5 Glossary

[TI Glossary](#) This glossary lists and explains terms, acronyms, and definitions.

11 Mechanical, Packaging, and Orderable Information

The following pages include mechanical, packaging, and orderable information. This information is the most current data available for the designated devices. This data is subject to change without notice and revision of this document. For browser-based versions of this data sheet, refer to the left-hand navigation.

PACKAGING INFORMATION

Orderable part number	Status (1)	Material type (2)	Package Pins	Package qty Carrier	RoHS (3)	Lead finish/ Ball material (4)	MSL rating/ Peak reflow (5)	Op temp (°C)	Part marking (6)
TPS22995HQDDCRQ1	Active	Production	SOT-23-THIN (DDC) 6	3000 LARGE T&R	Yes	Call TI Sn	Level-1-260C-UNLIM	-40 to 125	995H
TPS22995HQDDCRQ1.A	Active	Production	SOT-23-THIN (DDC) 6	3000 LARGE T&R	Yes	SN	Level-1-260C-UNLIM	-40 to 125	995H

(1) **Status:** For more details on status, see our [product life cycle](#).

(2) **Material type:** When designated, preproduction parts are prototypes/experimental devices, and are not yet approved or released for full production. Testing and final process, including without limitation quality assurance, reliability performance testing, and/or process qualification, may not yet be complete, and this item is subject to further changes or possible discontinuation. If available for ordering, purchases will be subject to an additional waiver at checkout, and are intended for early internal evaluation purposes only. These items are sold without warranties of any kind.

(3) **RoHS values:** Yes, No, RoHS Exempt. See the [TI RoHS Statement](#) for additional information and value definition.

(4) **Lead finish/Ball material:** Parts may have multiple material finish options. Finish options are separated by a vertical ruled line. Lead finish/Ball material values may wrap to two lines if the finish value exceeds the maximum column width.

(5) **MSL rating/Peak reflow:** The moisture sensitivity level ratings and peak solder (reflow) temperatures. In the event that a part has multiple moisture sensitivity ratings, only the lowest level per JEDEC standards is shown. Refer to the shipping label for the actual reflow temperature that will be used to mount the part to the printed circuit board.

(6) **Part marking:** There may be an additional marking, which relates to the logo, the lot trace code information, or the environmental category of the part.

Multiple part markings will be inside parentheses. Only one part marking contained in parentheses and separated by a "~" will appear on a part. If a line is indented then it is a continuation of the previous line and the two combined represent the entire part marking for that device.

Important Information and Disclaimer: The information provided on this page represents TI's knowledge and belief as of the date that it is provided. TI bases its knowledge and belief on information provided by third parties, and makes no representation or warranty as to the accuracy of such information. Efforts are underway to better integrate information from third parties. TI has taken and continues to take reasonable steps to provide representative and accurate information but may not have conducted destructive testing or chemical analysis on incoming materials and chemicals. TI and TI suppliers consider certain information to be proprietary, and thus CAS numbers and other limited information may not be available for release.

In no event shall TI's liability arising out of such information exceed the total purchase price of the TI part(s) at issue in this document sold by TI to Customer on an annual basis.

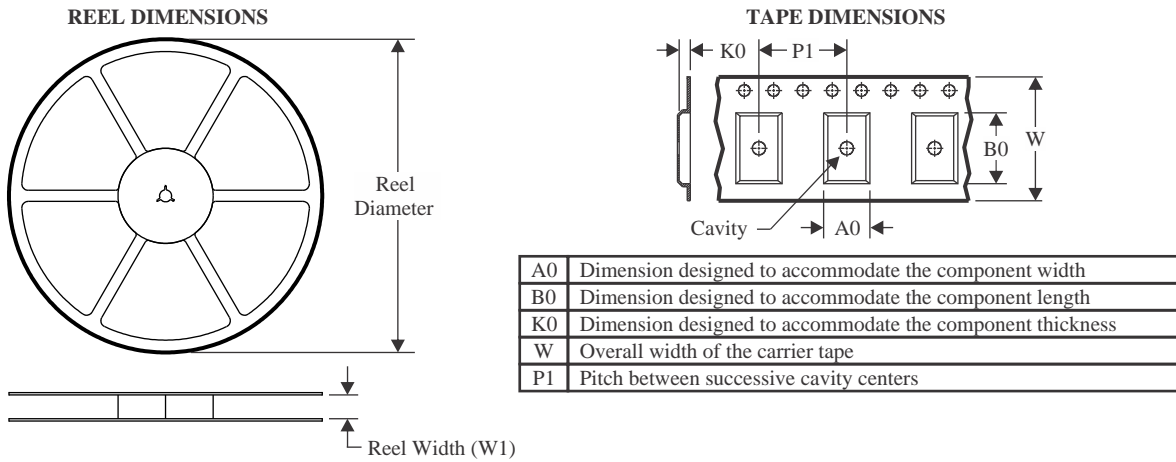
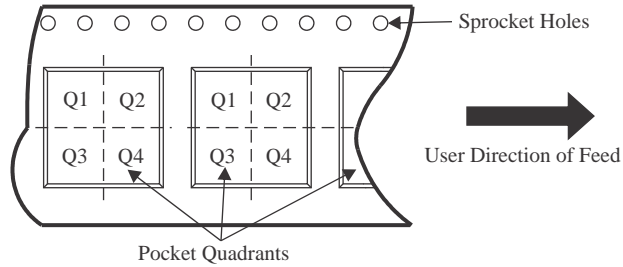
TAPE AND REEL INFORMATION

QUADRANT ASSIGNMENTS FOR PIN 1 ORIENTATION IN TAPE

*All dimensions are nominal

Device	Package Type	Package Drawing	Pins	SPQ	Reel Diameter (mm)	Reel Width W1 (mm)	A0 (mm)	B0 (mm)	K0 (mm)	P1 (mm)	W (mm)	Pin1 Quadrant
TPS22995HQDDCRQ1	SOT-23-THIN	DDC	6	3000	180.0	8.4	3.2	3.2	1.4	4.0	8.0	Q3

TAPE AND REEL BOX DIMENSIONS

*All dimensions are nominal

Device	Package Type	Package Drawing	Pins	SPQ	Length (mm)	Width (mm)	Height (mm)
TPS22995HQDDCRQ1	SOT-23-THIN	DDC	6	3000	210.0	185.0	35.0

EXAMPLE BOARD LAYOUT

DDC0006A

SOT-23 - 1.1 max height

SMALL OUTLINE TRANSISTOR

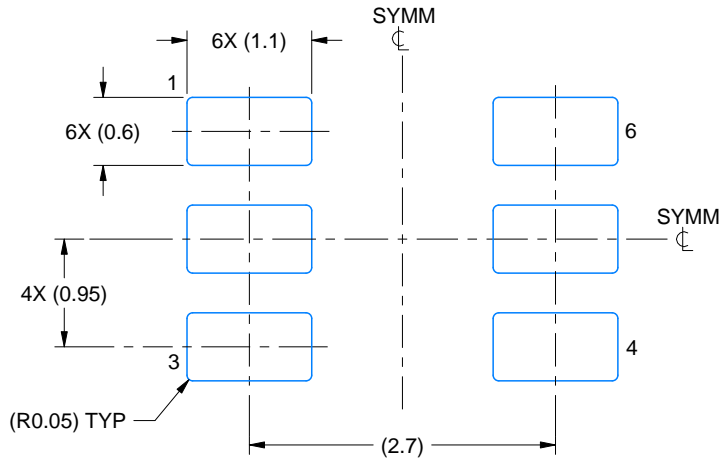

LAND PATTERN EXAMPLE
EXPLODED METAL SHOWN
SCALE:15X

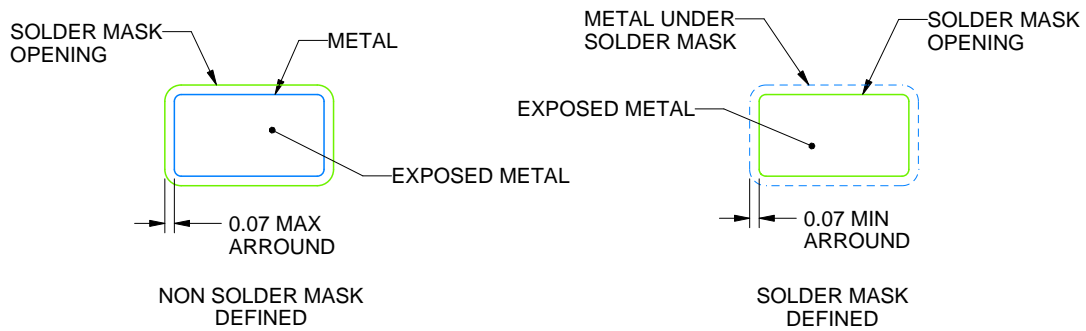

SOLDEMASK DETAILS

4214841/E 08/2024

NOTES: (continued)

- 4. Publication IPC-7351 may have alternate designs.
- 5. Solder mask tolerances between and around signal pads can vary based on board fabrication site.

EXAMPLE STENCIL DESIGN

DDC0006A

SOT-23 - 1.1 max height

SMALL OUTLINE TRANSISTOR

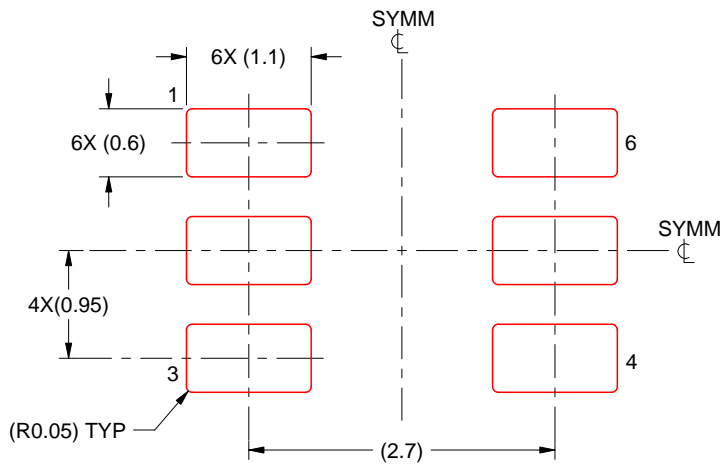

SOLDER PASTE EXAMPLE
BASED ON 0.125 THICK STENCIL
SCALE:15X

4214841/E 08/2024

NOTES: (continued)

6. Laser cutting apertures with trapezoidal walls and rounded corners may offer better paste release. IPC-7525 may have alternate design recommendations.
7. Board assembly site may have different recommendations for stencil design.

IMPORTANT NOTICE AND DISCLAIMER

TI PROVIDES TECHNICAL AND RELIABILITY DATA (INCLUDING DATASHEETS), DESIGN RESOURCES (INCLUDING REFERENCE DESIGNS), APPLICATION OR OTHER DESIGN ADVICE, WEB TOOLS, SAFETY INFORMATION, AND OTHER RESOURCES "AS IS" AND WITH ALL FAULTS, AND DISCLAIMS ALL WARRANTIES, EXPRESS AND IMPLIED, INCLUDING WITHOUT LIMITATION ANY IMPLIED WARRANTIES OF MERCHANTABILITY, FITNESS FOR A PARTICULAR PURPOSE OR NON-INFRINGEMENT OF THIRD PARTY INTELLECTUAL PROPERTY RIGHTS.

These resources are intended for skilled developers designing with TI products. You are solely responsible for (1) selecting the appropriate TI products for your application, (2) designing, validating and testing your application, and (3) ensuring your application meets applicable standards, and any other safety, security, regulatory or other requirements.

These resources are subject to change without notice. TI grants you permission to use these resources only for development of an application that uses the TI products described in the resource. Other reproduction and display of these resources is prohibited. No license is granted to any other TI intellectual property right or to any third party intellectual property right. TI disclaims responsibility for, and you fully indemnify TI and its representatives against any claims, damages, costs, losses, and liabilities arising out of your use of these resources.

TI's products are provided subject to [TI's Terms of Sale](#), [TI's General Quality Guidelines](#), or other applicable terms available either on [ti.com](#) or provided in conjunction with such TI products. TI's provision of these resources does not expand or otherwise alter TI's applicable warranties or warranty disclaimers for TI products. Unless TI explicitly designates a product as custom or customer-specified, TI products are standard, catalog, general purpose devices.

TI objects to and rejects any additional or different terms you may propose.

Copyright © 2025, Texas Instruments Incorporated

Last updated 10/2025

Looking for pricing, stock, or lifecycle information?

Click below to explore more details on WIN SOURCE:

 [View TPM27224-SO1R on WIN SOURCE](#)

 [3Peak Information](#)

Optimize Your Supply Chain with WIN SOURCE Solutions

-  Global Sourcing Solution
-  Obsolete Management
-  Cost Control Management
-  Shortage Management
-  Alternative Solution
-  Excess Inventory Management