



**THE DATASHEET OF
TPA8304-TS2R-S**



TPS6287x-Q1 2.7V to 6V Input, 15A, 20A, 25A, and 30A Automotive, Fast Transient, Synchronous Step-Down Converter With I²C Interface and Remote Sense

1 Features

- AEC-Q100 qualified for automotive applications
 - Device temperature grade 1: -40°C to 125°C T_A
 - -40°C to 150°C junction temperature range
- Functional Safety-Capable
 - Documentation available to aid functional safety system design
- Input voltage range: 2.7V to 6V
- Family of pin-to-pin compatible devices: 15A, 20A, 25A, and 30A
- Three selectable output voltage ranges from 0.4V to 1.675V
 - 0.4V to 0.71875V with 1.25mV steps
 - 0.4V to 1.0375V with 2.5mV steps
 - 0.4V to 1.675V with 5mV steps
- Output voltage accuracy: $\pm 0.8\%$
- Internal power MOSFETs: 2.6m Ω and 1.5m Ω
- Adjustable soft start
- External compensation
- Selectable start-up output voltage through the VSEL pin
- Selectable switching frequency of 1.5MHz, 2.25MHz, 2.5MHz, or 3MHz through FSEL pin
- Forced PWM or power-save mode operation
- Start-up output voltage selection by external resistor or I²C
- I²C-compatible interface with up to 3.4MHz
- Optional stacked operation for increased output current capability
- Differential remote sense
- Thermal pre-warning and thermal shutdown
- Output discharge
- Optional spread spectrum clocking
- Power-good output with window comparator

2 Applications

- ADAS camera, ADAS sensor fusion
- Surround view ECU
- Hybrid and reconfigurable cluster
- Head unit, telematics control unit

3 Description

The TPS62874-Q1, TPS62875-Q1, TPS62876-Q1 and TPS62877-Q1 are a family of pin-to-pin, 15A, 20A, 25A, and 30A synchronous step-down DC/DC converters with I²C interface and differential remote sense. All devices offer high efficiency and ease of use. Low-resistance power switches allow up to

30A output current at high ambient temperature. The devices can operate in stacked mode to deliver higher output currents or to spread the power dissipation across multiple devices.

The TPS6287x-Q1 family implements a fixed-frequency DCS-Control scheme that supports a fast transient response. The devices can operate in power-save mode for maximum efficiency or forced-PWM mode for best transient performance and lowest output voltage ripple.

An optional remote sensing feature maximizes voltage regulation at the point-of-load, and the device achieves $\pm 0.8\%$ DC voltage accuracy for the full output voltage range.

The switching frequency is selectable through the FSEL pin, and can be set to 1.5MHz, 2.25MHz, 2.5MHz, or 3MHz, or synchronized to an external clock in the same frequency range.

The I²C compatible interface offers several control, monitoring and warning features, such as voltage monitoring and temperature related warnings. The output voltage can be quickly adjusted to adapt the load's power consumption to the performance needs. The default start-up voltage is resistor selectable through the VSEL pin.

Device Information

PART NUMBER ⁽³⁾	CURRENT RATING	PACKAGE ⁽¹⁾	PACKAGE SIZE ⁽²⁾
TPS62874-Q1	15A	RZV (WQFN-FCRLF, 24)	3.05mm × 4.05mm
TPS62875-Q1	20A		
TPS62876-Q1	25A		
TPS62877-Q1	30A		

(1) For more information, see Section 13.

(2) The package size (length × width) is a nominal value and includes pins, where applicable.

(3) See the Device Options table.

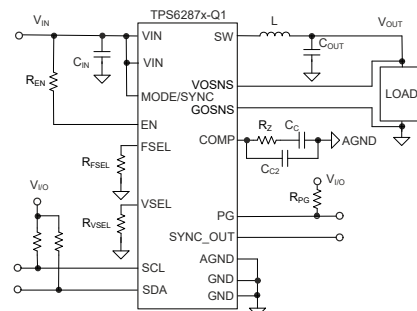

Simplified Schematic



Table of Contents

1 Features	1	10 Application and Implementation	42
2 Applications	1	10.1 Application Information.....	42
3 Description	1	10.2 Typical Application.....	42
4 Device Options	3	10.3 Typical Application Using Two TPS62876-Q1 in a Stacked Configuration.....	50
5 Pin Configuration and Functions	4	10.4 Typical Application Using Three TPS62876-Q1 in a Stacked Configuration.....	55
6 Specifications	6	10.5 Best Design Practices.....	59
6.1 Absolute Maximum Ratings.....	6	10.6 Power Supply Recommendations.....	59
6.2 ESD Ratings - Q100.....	6	10.7 Layout.....	59
6.3 Recommended Operating Conditions.....	6	11 Device and Documentation Support	62
6.4 Thermal Information.....	7	11.1 Documentation Support.....	62
6.5 Electrical Characteristics.....	7	11.2 Receiving Notification of Documentation Updates..	62
6.6 I ² C Interface Timing Requirements.....	11	11.3 Support Resources.....	62
6.7 Typical Characteristics.....	13	11.4 Trademarks.....	62
7 Parameter Measurement Information	14	11.5 Electrostatic Discharge Caution.....	62
8 Detailed Description	15	11.6 Glossary.....	62
8.1 Overview.....	15	12 Revision History	62
8.2 Functional Block Diagram.....	15	13 Mechanical, Packaging, and Orderable Information	64
8.3 Feature Description.....	16		
8.4 Device Functional Modes.....	31		
8.5 Programming.....	32		
9 Device Registers	36		

4 Device Options

DEVICE NUMBER	OUTPUT CURRENT	VSEL SETTING FOR START-UP VOLTAGE AND I2C ADDRESS	SOFT-START TIME AND OTHER CONFIGURATION SETTINGS
TPS62874QWRZVRQ1	15A	VSEL with 6.2kΩ to GND: 0.80V, 0x44 VSEL shorted to GND: 0.75V, 0x45 VSEL shorted to VIN: 0.875V, 0x46 VSEL with 47kΩ to VIN: 0.58V, 0x47	SSTIME = 1ms SSCEN = 0 DROOPEN = 0 Transient non-sync. mode = Off SYNC_OUT_PHASE = 120°
TPS62875QWRZVRQ1	20A		
TPS62876QWRZVRQ1	25A		
TPS62877QWRZVRQ1	30A		
TPS62874B1QWRZVRQ1	15A	VSEL with 6.2kΩ to GND: 0.8V, 0x44 VSEL shorted to GND: 0.8V, 0x45 VSEL shorted to VIN: 0.875V, 0x46 VSEL with 47kΩ to VIN: 0.8V, 0x47	SSTIME = 1ms SSCEN = 0 DROOPEN = 1 Transient non-sync. mode = ON SYNC_OUT_PHASE = 120°
TPS62875B1QWRZVRQ1	20A		
TPS62876B1QWRZVRQ1	25A		
TPS62877B1QWRZVRQ1	30A		
TPS62875B2QWRZVRQ1	20A	VSEL with 6.2kΩ to GND: 0.85V, 0x44 VSEL shorted to GND: 0.75V, 0x45 VSEL shorted to VIN: 0.875V, 0x46 VSEL with 47kΩ to VIN: 0.8V, 0x47	SSTIME = 1ms SSCEN = 0 DROOPEN = 1 Transient non-sync. mode = ON SYNC_OUT_PHASE = 120°
TPS62875B3QWRZVRQ1	20A	VSEL with 6.2kΩ to GND: 0.73V, 0x44 VSEL shorted to GND: 0.75V, 0x45 VSEL shorted to VIN: 0.8V, 0x46 VSEL with 47kΩ to VIN: 0.77V, 0x47	SSTIME = 1ms SSCEN = 1 DROOPEN = 1 Transient non-sync. mode = ON SYNC_OUT_PHASE = 120°
TPS62876B3QWRZVRQ1	25A	VSEL with 6.2kΩ to GND: 0.845V, 0x44 VSEL shorted to GND: 0.75V, 0x45 VSEL shorted to VIN: 0.8V, 0x46 VSEL with 47kΩ to VIN: 0.9V, 0x47	SSTIME = 1ms SSCEN = 1 DROOPEN = 1 Transient non-sync. mode = ON SYNC_OUT_PHASE = 120°
TPS62877B3QWRZVRQ1	30A		
TPS62874B4QWRZVRQ1	15A	VSEL with 6.2kΩ to GND: 0.7V, 0x44 VSEL shorted to GND: 0.75V, 0x45 VSEL shorted to VIN: 0.765V, 0x46 VSEL with 47kΩ to VIN: 0.85V, 0x47	SSTIME = 1ms SSCEN = 0 DROOPEN = 1 Transient non-sync. mode = ON SYNC_OUT_PHASE = 120°
TPS62875B4QWRZVRQ1	20A		
TPS62875B5QWRZVRQ1	20A	VSEL with 6.2kΩ to GND: 0.725V, 0x44 VSEL shorted to GND: 0.75V, 0x45 VSEL shorted to VIN: 0.765V, 0x46 VSEL with 47kΩ to VIN: 0.85V, 0x47	SSTIME = 1ms SSCEN = 0 DROOPEN = 1 Transient non-sync. mode = ON SYNC_OUT_PHASE = 120°
TPS62875B6QWRZVRQ1	20A	VSEL with 6.2kΩ to GND: 0.8V, 0x44 VSEL shorted to GND: 0.75V, 0x45 VSEL shorted to VIN: 0.85V, 0x46 VSEL with 47kΩ to VIN: 0.9V, 0x47	SSTIME = 0.5ms SSCEN = 0 DROOPEN = 0 Transient non-sync. mode = OFF SYNC_OUT_PHASE = 180°

5 Pin Configuration and Functions

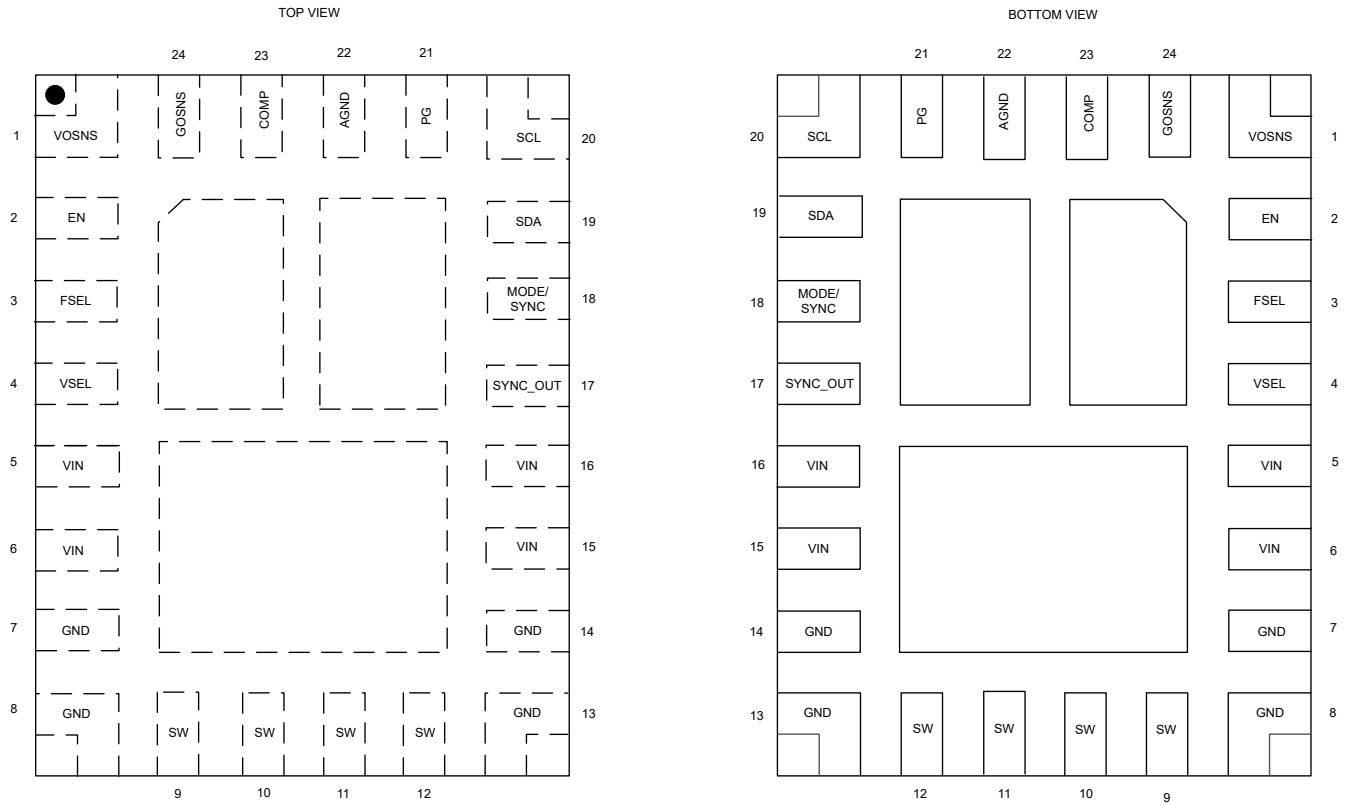

Figure 5-1. RZV Package 24 Pin WQFN-FCRLF

Table 5-1. Pin Functions

PIN		TYPE ⁽¹⁾	DESCRIPTION
NO.	NAME		
1	VOSNS	I	Output voltage sense (differential output voltage sensing).
2	EN	I	This pin is the enable pin of the device. Connect to this pin using a series resistor of at least 15kΩ. A logic low level on this pin disables the device, and a logic high level on the pin enables the device. Do not leave this pin unconnected. For stacked operation interconnect EN pins of all stacked devices with a resistor to the supply voltage or a GPIO of a processor. See Stacked Operation for a detailed description.
3	FSEL	I	Frequency select pin. A resistor or a short circuit to GND or V _{IN} determines the switching frequency if not externally synchronized. See Switching Frequency Selection for the frequency options.
4	VSEL	I	Start-up output voltage set pin. A resistor or short circuit to GND or V _{IN} defines the selected output voltage.
5, 6, 15, 16	VIN	P	Power supply input. Connect the input capacitor as close as possible between pin VIN and GND.
7, 8, 13, 14	GND	GND	Ground pin
9, 10, 11, 12	SW	O	This is the switch pin of the converter and is connected to the internal Power MOSFETs.

Table 5-1. Pin Functions (continued)

PIN		TYPE ⁽¹⁾	DESCRIPTION
NO.	NAME		
17	SYNCOUT	O	Internal clock output pin for synchronization in stacked mode. Leave this pin floating for single device operation. Connect this pin to the MODE/SYNC pin of the succeeding device in the daisy-chain in stacked operation. Do not use this pin to connect to a non-TPS6287x-Q1 device. During start-up, this pin is used to identify if a device must operate as a secondary converter in stacked operation. Connect a 47kΩ resistor from this pin to GND to define a secondary converter in stacked operation. See Stacked Operation for a detailed description.
18	MODE/SYNC	I	The device runs in Power-Save mode when this pin is pulled low. If the pin is pulled high, the device runs in Forced-PWM mode. Do not leave this pin unconnected. The mode pin can also be used to synchronize the device to an external clock.
19	SDA	I/O	I ² C serial data pin. Do not leave this pin floating. Connect a pullup to logic high level. Connect to GND for secondary devices in stacked operation.
20	SCL	I/O	I ² C serial clock pin. Do not leave this pin floating. Connect a pullup resistor to a logic high level. Connect to GND for secondary devices in stacked operation.
21	PG	I/O	Open drain power good output. Low impedance when not "power good", high impedance when "power good". This pin can be left open or be tied to GND when not used in single device operation. In stacked operation interconnect the PG pins of all stacked devices. Only the PG pin of the primary converter in stacked operation is an open drain output. For devices that are defined as secondary converters in stacked mode the pin is an input pin. See Stacked Operation for a detailed description.
22	AGND	GND	Analog Ground. Connect to GND.
23	COMP	—	Device compensation input. A resistor and capacitor from this pin to AGND define the compensation of the control loop. In stacked operation connect the COMP pins of all stacked devices together and connect a resistor and capacitor between the common COMP node and AGND.
24	GOSNS	I	Output ground sense (differential output voltage sensing)
Exposed Thermal Pads		—	The thermal pads must be soldered to GND to achieve an appropriate thermal resistance and for mechanical stability.

(1) I = input, O = output, P = power, GND = ground

6 Specifications

6.1 Absolute Maximum Ratings

over operating temperature range (unless otherwise noted)⁽¹⁾

		MIN	MAX	UNIT
Voltage ⁽²⁾	VIN ⁽⁴⁾	-0.3	6.5	V
	SW (DC)	-0.3	V _{IN} + 0.3	V
	COMP	-0.3	V _{IN}	V
	SW (AC, less than 10ns) ⁽³⁾	-3	10	V
	VOSNS	-0.3	1.8	V
Voltage ⁽²⁾	SCL, SDA	-0.3	5.5	V
Voltage ⁽²⁾	SYNC_OUT	-0.3	2	V
Voltage ⁽²⁾	PG	-0.3	6.5	V
Voltage ⁽²⁾	FSEL, VSEL, EN, MODE/SYNC ⁽⁴⁾	-0.3	6.5	V
Voltage ⁽²⁾	GOSNS	-0.3	0.3	V
T _{stg}	Storage temperature	-65	150	°C

- (1) Operation outside the Absolute Maximum Ratings may cause permanent device damage. Absolute Maximum Ratings do not imply functional operation of the device at these or any other conditions beyond those listed under Recommended Operating Conditions. If used outside the Recommended Operating Conditions but within the Absolute Maximum Ratings, the device may not be fully functional, and this may affect device reliability, functionality, performance, and shorten the device lifetime.
- (2) All voltage values are with respect to the network ground terminal.
- (3) While switching.
- (4) The voltage at the pin can exceed the 6.5V absolute max condition for a short period of time, but must remain less than 8V. VIN at 8V for a 100ms duration is equivalent to approximately 8 hours of aging for the device at room temperature.

6.2 ESD Ratings - Q100

			VALUE	UNIT
V _(ESD)	Electrostatic discharge	Human body model (HBM), per AEC Q100-002 ⁽¹⁾ HBM ESD classification level 2	±2000	V
V _(ESD)	Electrostatic discharge	Charged device model (CDM) per AEC Q100-011 CDM ESD classification level C5	±750	V

- (1) AEC Q100-002 indicates that HBM stressing must be in accordance with the ANSI/ESDA/JEDEC JS-001 specification.

6.3 Recommended Operating Conditions

Over operating temperature range (unless otherwise noted)

		MIN	NOM	MAX	UNIT
V _{IN}	Input voltage range	2.7		6	V
V _{OUT}	Output voltage range	0.4		1.675 V or (V _{IN} - 1.5 V) ⁽¹⁾	V
Voltage	Nominal pull-up voltage on pins SDA and SCL	1.2		5	V
L	Effective inductance for f _{SW} = 1.5MHz	100	150	200	nH
L	Effective inductance for f _{SW} = 2.25MHz, 2.5MHz and 3MHz	40	100	200	nH
C _{IN}	Effective input capacitance per power input pin	10	22		µF
C _{OUT}	Effective output capacitance	47		⁽³⁾	µF
C _{PAR}	Parasitic capacitance on FSEL, VSEL pin			100	pF
C _{PAR}	Parasitic capacitance on SYNC_OUT pin			20	pF
R _{EN}	Pull-up resistance on EN pin	15			kΩ
R _{VSEL} , R _{FSEL}	Resistance on VSEL, FSEL pin to GND if not directly tied to GND or VIN		6.2		kΩ

6.3 Recommended Operating Conditions (continued)

Over operating temperature range (unless otherwise noted)

		MIN	NOM	MAX	UNIT
R_{VSEL} , R_{FSEL}	Resistance on VSEL, FSEL pin to VIN if not directly tied to GND or VIN		47		k Ω
R_{VSEL} , R_{FSEL}	Resistor tolerance on VSEL, FSEL			$\pm 2\%$	
I_{SINK_PG}	Sink current at PG pin	0		1	mA
T_J	Operating junction temperature ⁽²⁾	-40		150	$^{\circ}\text{C}$

- (1) Whatever V_{OUT} value is lower.
- (2) Operating lifetime is derated at junction temperatures greater than 125 $^{\circ}\text{C}$.
- (3) The maximum recommended output capacitance depends on the specific operating conditions of an application. Output capacitance values of up to a few millifarads are typically possible.

6.4 Thermal Information

THERMAL METRIC ⁽¹⁾		TPS6287x-Q1	TPS6287x-Q1	UNIT
		RZV (JEDEC)	RZV (EVM)	
		24 PINS	24 PINS	
$R_{\theta JA}$	Junction-to-ambient thermal resistance	34.7	28	$^{\circ}\text{C}/\text{W}$
$R_{\theta JC(top)}$	Junction-to-case (top) thermal resistance	14.9	-	$^{\circ}\text{C}/\text{W}$
$R_{\theta JB}$	Junction-to-board thermal resistance	6.5	-	$^{\circ}\text{C}/\text{W}$
Ψ_{JT}	Junction-to-top characterization parameter	1.5	-	$^{\circ}\text{C}/\text{W}$
Y_{JB}	Junction-to-board characterization parameter	6.5	-	$^{\circ}\text{C}/\text{W}$
$R_{\theta JC(bot)}$	Junction-to-case (bottom) thermal resistance	4.8	-	$^{\circ}\text{C}/\text{W}$

- (1) For more information about traditional and new thermal metrics, see the [Semiconductor and IC Package Thermal Metrics](#) application note.

6.5 Electrical Characteristics

over operating junction temperature ($T_J = -40^{\circ}\text{C}$ to $+150^{\circ}\text{C}$) and $V_{IN} = 2.7\text{ V}$ to 6 V . Typical values at $V_{IN} = 5\text{ V}$ and $T_J = 25^{\circ}\text{C}$ (unless otherwise noted).

PARAMETER		TEST CONDITIONS	MIN	TYP	MAX	UNIT
SUPPLY						
I_Q	Quiescent current	EN = High, $I_{OUT} = 0\text{mA}$, device not switching; MODE = Low		2.1	3.8	mA
I_{SD}	Shutdown current	EN = Low, $V_{(SW)} = 0\text{ V}$, max value at $T_J = 125^{\circ}\text{C}$		18	450	μA
$V_{IT+ (UVLO)}$	Positive-going UVLO threshold voltage (VIN)		2.5	2.6	2.7	V
$V_{IT- (UVLO)}$	Negative-going UVLO threshold voltage (VIN)		2.4	2.5	2.6	V
$V_{hys(UVLO)}$	UVLO hysteresis voltage (VIN)		80			mV
$V_{IT+ (OVLO)}$	Positive-going OVLO threshold voltage (VIN)		6.1	6.3	6.5	V
$V_{IT- (OVLO)}$	Negative-going OVLO threshold voltage (VIN)		6.0	6.2	6.4	V
$V_{hys(OVLO)}$	OVLO hysteresis voltage (VIN)		80			mV
$V_{IT- (POR)}$	Negative-going power-on reset threshold voltage (VIN)		1.4			V

6.5 Electrical Characteristics (continued)

over operating junction temperature ($T_J = -40\text{ }^\circ\text{C}$ to $+150\text{ }^\circ\text{C}$) and $V_{IN} = 2.7\text{ V}$ to 6 V . Typical values at $V_{IN} = 5\text{ V}$ and $T_J = 25\text{ }^\circ\text{C}$ (unless otherwise noted).

PARAMETER		TEST CONDITIONS	MIN	TYP	MAX	UNIT
T_{SD}	Thermal shutdown threshold temperature	T_J rising		170		$^\circ\text{C}$
	Thermal shutdown hysteresis			20		$^\circ\text{C}$
T_W	Thermal warning threshold temperature	T_J rising		150		$^\circ\text{C}$
	Thermal warning hysteresis			20		$^\circ\text{C}$
CONTROL and INTERFACE						
V_{IT+}	Positive-going input threshold voltage (EN)		0.97	1.0	1.03	V
V_{IT-}	Negative-going input threshold voltage (EN)		0.87	0.9	0.93	V
V_{hys}	Hysteresis voltage (EN)		95			mV
$R_{(EN)}$	Input resistance to GND (EN)	Only active during start-up in stacked operation.	1.4	1.8	3	k Ω
I_{IH}	High-level input current (EN)	$V_{IH} = V_{IN}$, internal pulldown resistor disabled			3	μA
I_{IL}	Low-level input current (EN)	$V_{IL} = 0\text{V}$, internal pulldown resistor disabled	-200			nA
V_{IH}	High-level input voltage (MODE/SYNC, VSEL, FSEL, SYNC_OUT, PG)		0.8			V
V_{IH}	High-level input voltage (SDA, SCL)		0.95			V
V_{IL}	Low-level input voltage (MODE/SYNC, VSEL, FSEL, SYNC_OUT, PG)				0.4	V
V_{IL}	Low-level input voltage (SDA, SCL)				0.5	V
R_{IN}	Input resistance to GND on pins MODE/ SYNC, EN and PG		2	3	4	M Ω
V_{OL}	Low-level output voltage (SDA)	$I_{OL} = 9\text{mA}$			0.4	V
V_{OL}	Low-level output voltage (SDA)	$I_{OL} = 5\text{mA}$			0.2	V
I_{LKG}	Input leakage current into SDA, SCL	$V_{OH} = 3.3\text{V}$			200	nA
I_{IL}	Low-level input current (MODE/SYNC)	$V_{IL} = 0\text{V}$	-100		100	nA
I_{IH}	High-level input current (MODE/SYNC)	$V_{IH} = V_{IN}$			3	μA
I_{IL}	Low-level input current (SYNC_OUT)	$V_{IL} = 0\text{V}$	-230			nA
I_{IH}	High-level input current (SYNC_OUT)	$V_{IH} = 2\text{V}$			110	nA
V_{OL}	Low-level output voltage (SYNC_OUT)	$I_{OL} = 1\text{mA}$			0.3	V
V_{OH}	High-level output voltage (SYNC_OUT)	$I_{OH} = 0.1\text{mA}$	1.3		2.1	V
$t_{d(EN)1}$	Enable delay time when EN tied to V_{IN}	Measured from when EN goes high to when device starts switching, $SR_{V_{IN}} = 1\text{V}/\mu\text{s}$		200	600	μs
$t_{d(EN)2}$	Enable delay time when V_{IN} already applied	Measured from when EN goes high to when device starts switching		40	100	μs
$t_{d(Ramp)}$	Output voltage ramp time for CONTROL2[1:0] = 00	Measured from when device starts switching to rising edge of PG	0.35	0.5	0.65	ms
	Output voltage ramp time for CONTROL2[1:0] = 01		0.54	0.77	1.0	ms
	Output voltage ramp time for CONTROL2[1:0] = 10, default		0.7	1	1.3	ms
	Output voltage ramp time for CONTROL2[1:0] = 11		1.4	2	2.6	ms
$f_{(SYNC)}$	Synchronization clock frequency range (MODE/SYNC)	$f_{(SW)nom} = 1.5\text{MHz}$, $D_{(MODE/SYNC)} = 45\%\dots55\%$	1.2		1.8	MHz

6.5 Electrical Characteristics (continued)

over operating junction temperature ($T_J = -40\text{ }^\circ\text{C}$ to $+150\text{ }^\circ\text{C}$) and $V_{IN} = 2.7\text{ V}$ to 6 V . Typical values at $V_{IN} = 5\text{ V}$ and $T_J = 25\text{ }^\circ\text{C}$ (unless otherwise noted).

PARAMETER		TEST CONDITIONS	MIN	TYP	MAX	UNIT
	Synchronization clock frequency range (MODE/SYNC)	$f_{(SW)nom} = 2.25\text{MHz}$, $D_{(MODE/SYNC)} = 45\% \dots 55\%$	1.8		2.7	MHz
	Synchronization clock frequency range (MODE/SYNC)	$f_{(SW)nom} = 2.5\text{MHz}$, $D_{(MODE/SYNC)} = 45\% \dots 55\%$	2		3.0	MHz
$f_{(SYNC)}$	Synchronization clock frequency range (MODE/SYNC)	$f_{(SW)nom} = 3\text{MHz}$, $D_{(MODE/SYNC)} = 45\% \dots 55\%$	2.4		3.3	MHz
$D_{(MODE/SYNC)}$	Duty cycle of synchronization clock frequency (MODE/SYNC)		45		55	%
	Phase shift at SYNC_OUT with reference to internal CLK or external CLK	CONTROL2:SYNCH_OUT_PHASE = 0b0		120		°
	Phase shift at SYNC_OUT with reference to internal CLK or external CLK	CONTROL2:SYNCH_OUT_PHASE = 0b1		180		°
	Time to lock to external frequency			50		μs
	Resistance on FSEL, VSEL to GND if not tied to GND directly			6.2		$\text{k}\Omega$
	Resistance on FSEL, VSEL to VIN if not tied to VIN directly			47		$\text{k}\Omega$
$V_{T+(UVP)}$	Positive-going power good threshold voltage (output undervoltage)		94	96	98	%
$V_{T-(UVP)}$	Negative-going power good threshold voltage (output undervoltage)		92	94	96	%
$V_{T+(OVP)}$	Positive-going power good threshold voltage (output overvoltage)		104	106	108	%
$V_{T-(OVP)}$	Negative-going power good threshold voltage (output overvoltage)		102	104	106	%
V_{OL}	Low-level output voltage (PG)	$I_{OL} = 1\text{mA}$		0.012	0.3	V
I_{OH}	High-level output current (PG)	$V_{OH} = 5\text{V}$			3	μA
I_{IH}	High-level input current (PG)	Device configured as secondary device in stacked operation			3	μA
I_{IL}	Low-level input current (PG)	Device configured as secondary device in stacked operation	-1			μA
$t_{d(PG)}$	Deglintch time (PG)	High-to-low or low-to-high transition on the PG pin	34	40	46	μs
OUTPUT						
ΔV_{OUT}	Output voltage accuracy	$V_{IN} \geq V_{OUT} + 1.6\text{V}$, droop compensation disabled	-0.8		0.8	%
ΔV_{OUT}	Output voltage change from no current to rated current	droop compensation enabled		± 12		mV
	Accuracy of droop compensation voltage; TPS62874-Q1	device in forced PWM mode	-3.75		3.75	mV
	Accuracy of droop compensation voltage; TPS62875-Q1	device in forced PWM mode	-3.5		3.5	mV
	Accuracy of droop compensation voltage; TPS62876-Q1 and TPS62877-Q1	device in forced PWM mode	-3		3	mV
	Line regulation	$I_{OUT} = 15\text{A}$, $V_{IN} \geq V_{OUT} + 1.6\text{V}$		0.02		%/V
I_{IB}	Input bias current (GOSNS)	EN = High; $V_{(GOSNS)} = -100\text{mV}$ to 100mV	-60		3	μA
I_{IB}	Input bias current (VOSNS)	$V_{(VOSNS)} = 1.675\text{ V}$, $V_{IN} = 6\text{V}$, droop compensation disabled	-5.5		5.5	μA

6.5 Electrical Characteristics (continued)

over operating junction temperature ($T_J = -40\text{ }^\circ\text{C}$ to $+150\text{ }^\circ\text{C}$) and $V_{IN} = 2.7\text{ V}$ to 6 V . Typical values at $V_{IN} = 5\text{ V}$ and $T_J = 25\text{ }^\circ\text{C}$ (unless otherwise noted).

PARAMETER		TEST CONDITIONS	MIN	TYP	MAX	UNIT
I_{IB}	Input bias current (VOSNS)	$V_{(VOSNS)} = 1.675\text{V}$, $V_{IN} = 6\text{V}$, droop compensation enabled	-13.2		13.2	μA
V_{ICR}	Input common-mode range (GOSNS)		-100		100	mV
R_{DIS}	Output discharge resistance	$V_{OUT} \leq 1\text{V}$		2.7	9.2	Ω
f_{SW}	Switching frequency (SW)	$f_{SW} = 1.5\text{MHz}$, PWM operation	1.35	1.5	1.65	MHz
		$f_{SW} = 2.25\text{MHz}$, PWM operation	2.025	2.25	2.475	MHz
		$f_{SW} = 2.5\text{MHz}$, PWM operation	2.25	2.5	2.75	MHz
		$f_{SW} = 3\text{MHz}$, PWM operation	2.7	3	3.3	MHz
f_{SSC}	Modulation frequency		fsw/2048			kHz
Δf_{SW}	Switching frequency variation during spread spectrum operation		$f_{SW}-10\%$	$f_{SW}+10\%$		
gm	Transconductance of OTA on COMP pin			1.5		mS
τ	Emulated current time constant		11.87	12.5	13.2	μs
$R_{DS(ON)}$	High-side FET static on-resistance	$V_{IN} = 3.3\text{V}$		3.4	6.4	m Ω
$R_{DS(ON)}$	Low-side FET static on-resistance	$V_{IN} = 3.3\text{V}$		1.9	3.6	m Ω
$I_{(SW)(off)}$	SW pin current when HS-FET and LS-FET are off	$V_{IN} = 6\text{V}$; $V_{(SW)} = 0\text{V}$, $T_J = 25\text{ }^\circ\text{C}$	-1.5		0.1	μA
	SW pin current when HS-FET and LS-FET are off	$V_{IN} = 6\text{V}$; $V_{(SW)} = 6\text{V}$, $T_J = 25\text{ }^\circ\text{C}$	60		130	μA
	SW pin current when HS-FET and LS-FET are off	$V_{(SW)} = 0.4\text{V}$, current into SW pin		11	3000	μA
ILIM	High-side FET forward switch current limit, DC	TPS62874-Q1	19	22.5	26	A
ILIM	High-side FET forward switch current limit, DC	TPS62875-Q1	24	28.5	32	A
ILIM	High-side FET forward switch current limit, DC	TPS62876-Q1	29	34	39	A
ILIM	High-side FET forward switch current limit, DC	TPS62877-Q1	34	39	44	A
ILIM	Low-side FET forward switch current limit, DC	TPS62874-Q1	15	20	24	A
ILIM	Low-side FET forward switch current limit, DC	TPS62875-Q1	20	24.5	29	A
ILIM	Low-side FET forward switch current limit, DC	TPS62876-Q1	24.5	29	33	A
ILIM	Low-side FET forward switch current limit, DC	TPS62877-Q1	29.5	33.5	38	A
ILIM	Low-side FET negative current limit, DC			-10		A
$t_{on, min}$	Minimum on-time of HS FET	$V_{IN} = 3.3\text{V}$		45	53	ns
$t_{on, min}$	Minimum on-time of HS FET	$V_{IN} = 5\text{V}$		35	44	ns
$t_{off, min}$	Minimum off-time of HS FET	$V_{IN} = 5\text{V}$		70	100	ns
	Maximum duty cycle of power stage	for TPS62877-Q1 only		45		%

6.6 I²C Interface Timing Requirements

PARAMETER		TEST CONDITIONS	MIN	TYP	MAX	UNIT
f _{SCL}	SCL clock frequency	Standard mode			100	kHz
		Fast mode			400	kHz
		Fast mode plus			1	MHz
		High-speed mode (write operation), CB – 100pF max			3.4	MHz
		High-speed mode (read operation), CB – 100pF max			3.4	MHz
		High-speed mode (write operation), CB – 400pF max			1.7	MHz
		High-speed mode (read operation), CB – 400pF max			1.7	MHz
t _{HD} , t _{STA}	Hold time (repeated) START condition	Standard mode	4			μs
		Fast mode	0.6			μs
		Fast mode plus	0.26			μs
		High-speed mode	0.16			μs
t _{LOW}	LOW period of the SCL clock	Standard mode	4.7			μs
		Fast mode	1.3			μs
		Fast mode plus	0.5			μs
		High-speed mode, CB – 100pF max	0.16			μs
		High-speed mode, CB – 400pF max	0.32			μs
t _{HIGH}	HIGH period of the SCL clock	Standard mode	4			μs
		Fast mode	0.6			μs
		Fast mode plus	0.26			μs
		High-speed mode, CB – 100pF max	0.06			μs
		High-speed mode, CB – 400pF max	0.12			μs
t _{SU} , t _{STA}	Setup time for a repeated START condition	Standard mode	4.7			μs
		Fast mode	0.6			μs
		Fast mode plus	0.26			μs
		High-speed mode	0.16			μs
t _{SU} , t _{DAT}	Data setup time	Standard mode	250			ns
		Fast mode	100			ns
		Fast mode plus	50			ns
		High-speed mode, CB – 100pF max	10			ns
t _{HD} , t _{DAT}	Data hold time	Standard mode	0		3.45	μs
		Fast mode	0		0.9	μs
		Fast mode plus	0			μs
		High-speed mode, CB – 100pF max	0		70	ns
		High-speed mode, CB – 400pF max	0		150	ns
t _{RCL}	Rise time of both SDA and SCL signals	Standard mode			1000	ns
		Fast mode	20		300	ns
		Fast mode plus			120	ns
		High-speed mode, CB – 100pF max	10		40	ns
		High-speed mode, CB – 400pF max	20		80	ns

6.6 I²C Interface Timing Requirements (continued)

PARAMETER		TEST CONDITIONS	MIN	TYP	MAX	UNIT
t _{FCL}	Fall time of both SDA and SCL signals ⁽¹⁾	Standard mode			300	ns
		Fast mode	20 × V _{DD} /5.5 V		300	ns
		Fast mode plus	20 × V _{DD} /5.5 V		120	ns
		High-speed mode, CB – 100pF max		10	40	ns
		High-speed mode, CB – 400pF max		20	80	ns
t _{SU} , t _{STO}	Setup time of STOP Condition	Standard mode	4			μs
		Fast mode	0.6			μs
		Fast mode plus	0.26			μs
		High-Speed mode	0.16			μs
CB	Capacitive load for SDA and SCL	Standard mode			400	pF
		Fast mode			400	pF
		Fast mode plus			550	pF
		High-Speed mode			400	pF
t _{BUF}	Bus free time between a STOP and a START condition	Standard mode	4.7			μs
		Fast mode	1.3			μs
		Fast mode plus	0.5			μs

(1) V_{DD} is the pullup voltage of SDA and SCL.

6.7 Typical Characteristics

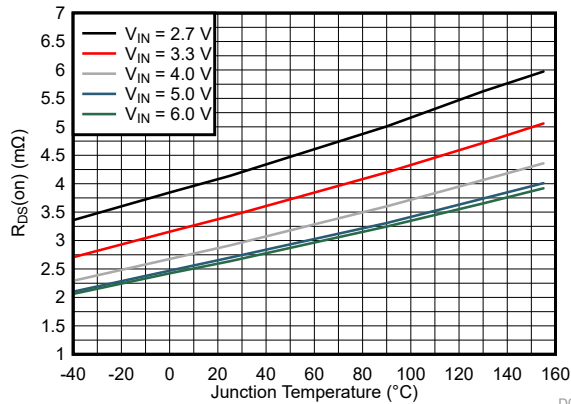

Figure 6-1. $R_{DS(ON)}$ of High Side Switch

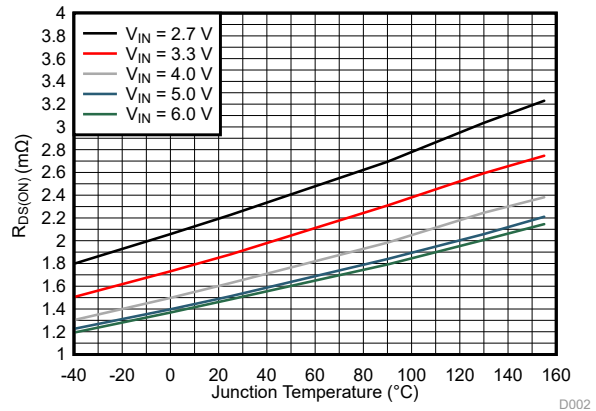

Figure 6-2. $R_{DS(ON)}$ of Low Side Switch

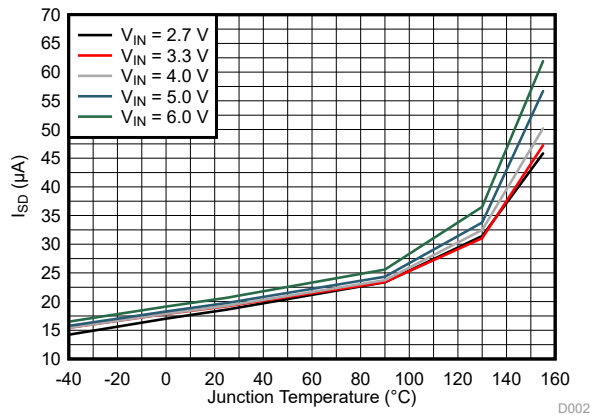

Figure 6-3. Shutdown Current vs Temperature

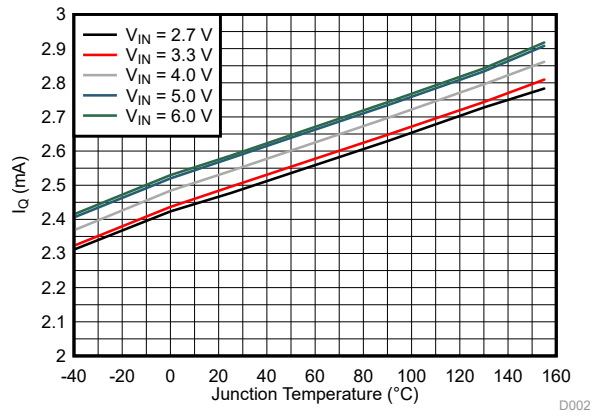

Figure 6-4. Quiescent Current vs Temperature

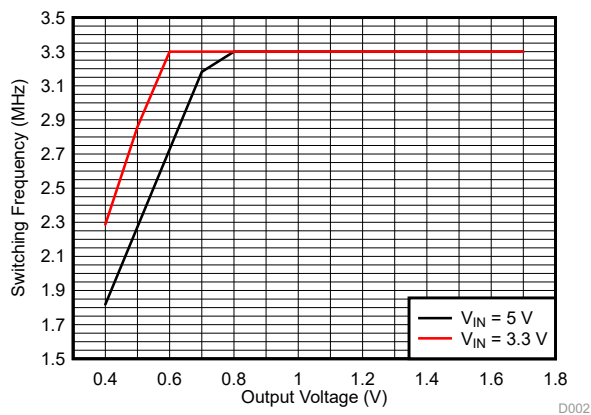

Figure 6-5. Maximum Switching Frequency vs Output Voltage

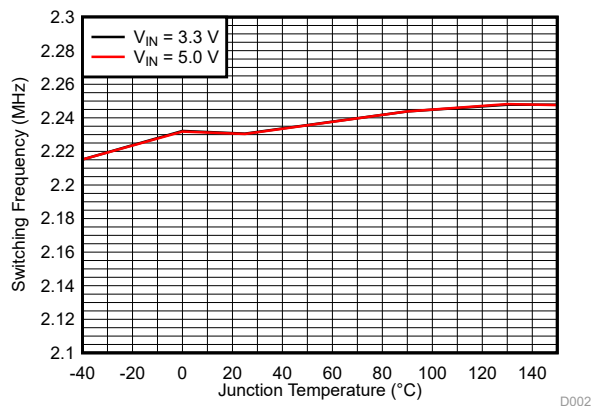

Figure 6-6. Switching Frequency vs Temperature

7 Parameter Measurement Information

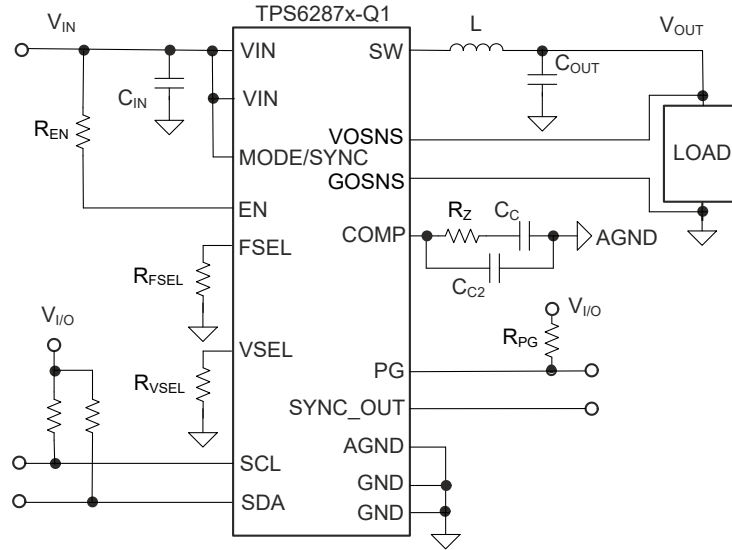

Figure 7-1. Measurement Setup for TPS6287x-Q1

Table 7-1. List of Components

Reference	Description	Manufacturer
IC	TPS62877QWRZVRQ1	Texas Instruments
L	IHSR2525CZ-56nH	Vishay
C _{IN}	6 × 10µF / 10V; GCM21BR71A106KE22L + 2 × 4.7µF / 10V; LMK107BJ475MAHT	Murata, Taiyo Yuden
C _{OUT}	2 × 22µF / 10V; GCM31CR71A226KE02L + 8 × 47µF / 6.3V; GCM32ER70J476ME19L + 3 × 100µF / 6.3V; GRT32ER60J107NE13L	Murata
C _C	1nF	any
R _Z	3.6kΩ	any
C _{C2}	4.7pF	any
R _{EN}	22kΩ	any
R _{FSEL}	0kΩ to GND	any
R _{VSEL}	6.2kΩ or 47kΩ or 0kΩ	any
R _{PG}	100kΩ	any

8 Detailed Description

8.1 Overview

The TPS6287x-Q1 devices are automotive-qualified, synchronous step-down (buck) DC/DC converters. These devices use an enhanced DCS-Control scheme that combines fast transient response with fixed frequency operation, which, together with the low output voltage ripple, high DC accuracy, and differential remote sensing makes them designed for supplying the cores of modern high-performance processors.

The four devices in this family are identical except for the current rating:

- The TPS62874-Q1 is a 15A rated device
- The TPS62875-Q1 is a 20A rated device
- The TPS62876-Q1 is a 25A rated device
- The TPS62877-Q1 is a 30A rated device

To further increase the output current capability, combine multiple devices in a *stack*. For example, a stack of two TPS62875-Q1 devices has a current capability of 40A.

The TPS6287x-Q1 devices have a built-in I²C-compatible interface to control and monitor the operation. If the I²C-compatible interface is not used, connect the SCL and SDA pins to GND.

8.2 Functional Block Diagram

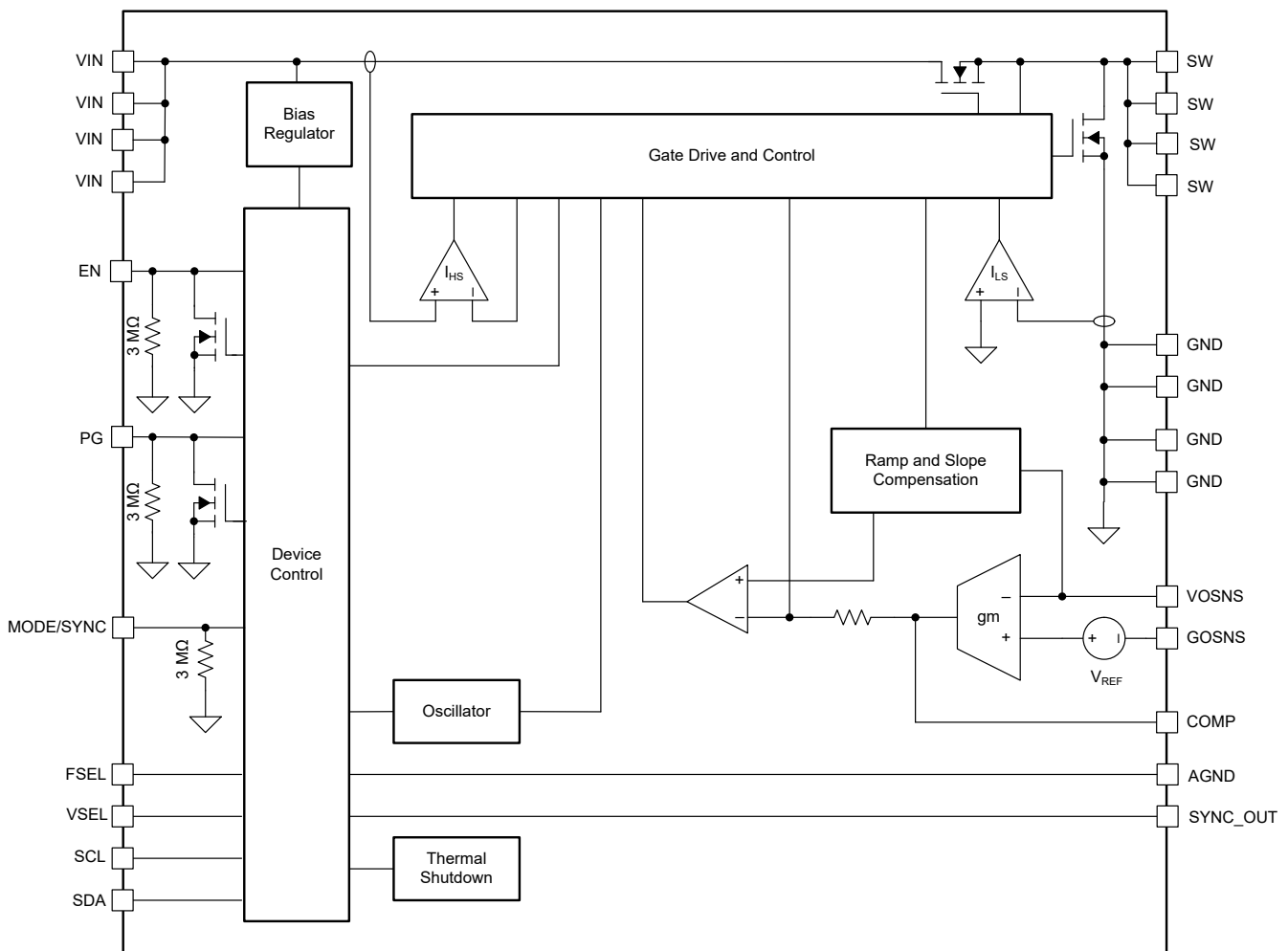

8.3 Feature Description

8.3.1 Fixed-Frequency DCS-Control Topology

Figure 8-1 shows a simplified block diagram of the fixed-frequency DCS-Control topology used in the TPS6287x-Q1 devices. This topology comprises an inner emulated current loop and an outer voltage-regulating loop.

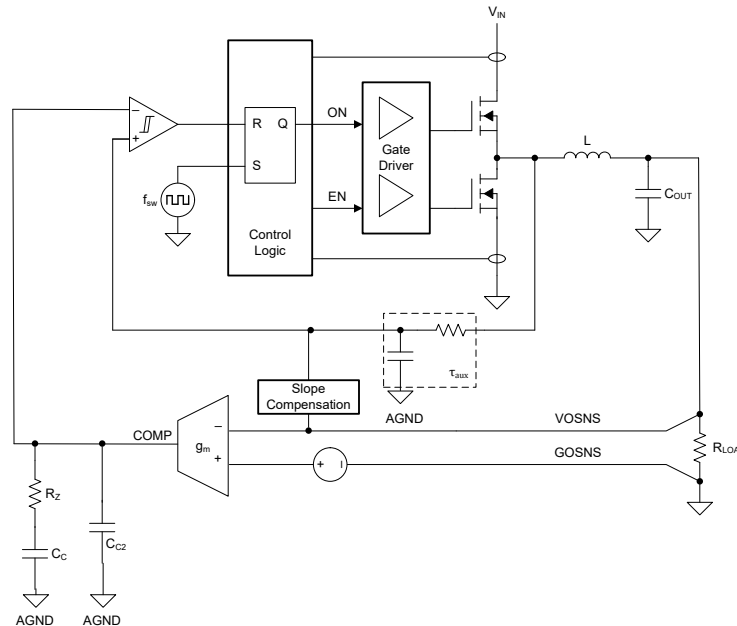

Figure 8-1. Fixed-Frequency DCS-Control Topology (Simplified)

8.3.2 Forced-PWM and Power-Save Modes

The device can control the inductor current in three different ways to regulate the output:

- Pulse-width modulation with continuous inductor current (PWM-CCM)
- Pulse-width modulation with discontinuous inductor current (PWM-DCM)
- Pulse-frequency modulation with discontinuous inductor current and pulse skipping (PFM-CCM)

During PWM-CCM operation, the device switches at a constant frequency and the inductor current is continuous (see Figure 8-2). PWM operation achieves the lowest output voltage ripple and the best transient performance.

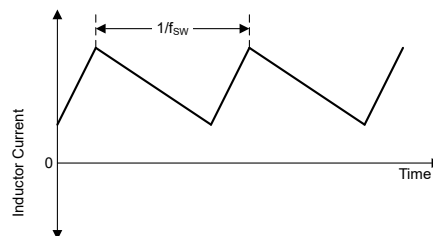

Figure 8-2. Continuous Conduction Mode (CCM) Current Waveform

During PWM-DCM operation the device switches at a constant frequency and the inductor current is discontinuous (see Figure 8-3). In this mode the device controls the peak inductor current to maintain the selected switching frequency while still being able to regulate the output.

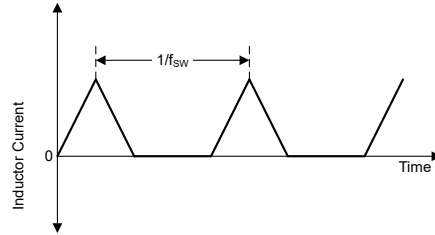

Figure 8-3. Discontinuous Conduction Mode (DCM) Waveform

During PFM-DCM operation the device keeps the peak inductor current constant (at a level corresponding to the minimum on-time of the converter) and skips pulses to regulate the output (see Figure 8-4). The switching pulses that occur during PFM-DCM operation are synchronized to the internal clock.

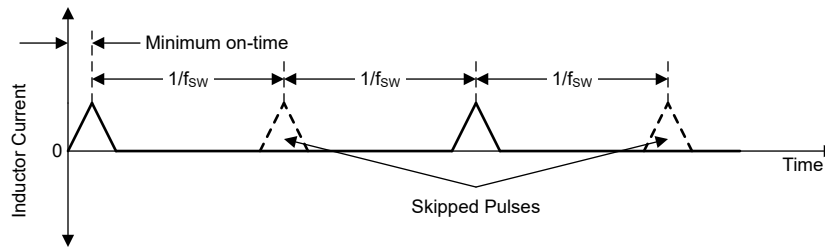

Figure 8-4. Discontinuous Conduction Mode (PFM-DCM) Current Waveform

Use Equation 1 to calculate the output current threshold at which the device enters PFM-DCM:

$$I_{OUT(PFM)} = \frac{(V_{IN} - V_{OUT})}{2L} t_{ON}^2 \left(\frac{V_{IN}}{V_{OUT}} \right) f_{sw} \quad (1)$$

The following figure shows how this threshold typically varies with V_{IN} and V_{OUT} for a switching frequency of 2.25MHz

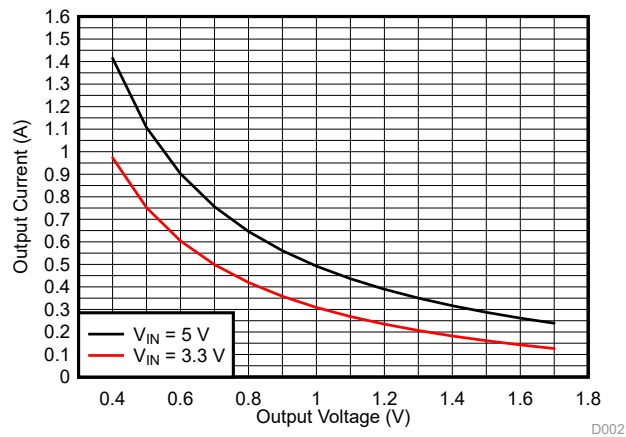

Figure 8-5. Output Current PFM-DCM Entry Threshold for $f_{sw} = 2.25\text{MHz}$

Configure the device to use either Forced-PWM (FPWM) mode or Power-Save Mode (PSM):

- In forced-PWM mode, the device uses PWM-CCM at all times.
- In power-save mode, the device uses PWM-CCM at medium and high loads, PWM-DCM at low loads, and PFM-DCM at very low loads. Transition between the different operating modes is seamless.

Table 8-1 shows the function table of the MODE/SYNC pin and the FPWMEN bit in the CONTROL1 register, which control the operating mode of the device.

Table 8-1. FPWM Mode and Power-Save Mode Selection

MODE/SYNC PIN	FPWMEN BIT	OPERATING MODE	REMARK
Low	0	PSM	Do not use in a stacked configuration
	1	FPWM	
High	X	FPWM	
Sync Clock	X	FPWM	

8.3.3 Transient Non-Synchronous Mode (optional)

The TPS6287x-Q1 has a transient non-synchronous mode that helps to minimize the output voltage overshoot during a load release. When the high side FET is turned off, the decay in inductor current is mainly determined by the output voltage as there is little voltage drop over the low side FET. For very low output voltages the current decays slowly so the output voltage overshoot is typically larger than the undershoot during a load step. Non-synchronous mode turns off the low side FET for 6 switching cycles so the inductor current decays through the body diode. This adds extra voltage across the inductor so the current decays quicker and the output voltage overshoot is lower.

8.3.4 Precise Enable

The Enable (EN) pin is bidirectional, and has two functions:

- As an input, the pin enables and disables the DC/DC converter in the device.
- As an output, the pin provides a SYSTEM_READY signal to other devices in a stacked configuration.

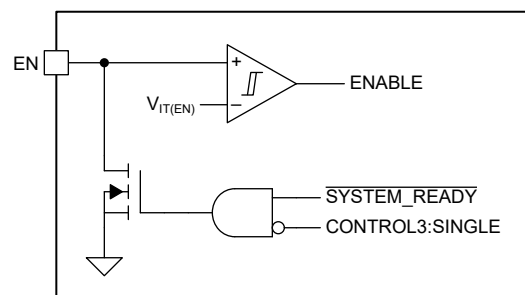

Figure 8-6. Enable Functional Block Diagram

Because there is an internal open-drain transistor connected to the EN pin, do not drive this pin directly from a low-impedance source. Instead, use a resistor to limit the current flowing into the EN pin (see Section 10.1).

When power is first applied to the VIN pin, the device pulls the EN pin low until the device has loaded the default register settings from nonvolatile memory and read the state of the VSEL, FSEL and SYNC_OUT pins. The device also pulls EN low if a fault such as thermal shutdown or overvoltage lockout occurs. In a stacked configuration all devices share a common enable signal, which means that the DC/DC converters in the stack cannot start to switch until *all* devices in the stack have completed the initialization. Similarly, a fault in one or more devices in the stack disables *all* converters in the stack (see Section 8.3.18).

In stand-alone (non-stacked) applications, you can disable the active pulldown of the EN pin if you set SINGLE = 1 in the CONTROL3 register. Fault conditions have no effect on the EN pin when SINGLE = 1. (Note that the EN pin is *always* pulled down during device initialization.) In stacked applications, make sure that SINGLE = 0.

When the internal SYSTEM_READY signal is low (that is, initialization is complete and there are no fault conditions), the internal open-drain transistor is high impedance and the EN pin functions like a standard input: A high level on the EN pin enables the DC/DC converter in the device and a low level disables the DC/DC

converter in the device. (The I²C interface is enabled as soon as the device has completed the initialization and is not affected by the state of the internal ENABLE or SYSTEM_READY signals.)

A low level on the EN pin forces the device into shutdown. During shutdown, the MOSFETs in the power stage are off, the internal control circuitry is disabled, and the device consumes only 20µA (typical).

The rising threshold voltage of the EN pin is 1.0V and the falling threshold voltage is 0.9V. The tolerance of the threshold voltages is ±30mV, which means that you can use the EN pin to implement precise turn-on and turn-off behavior.

8.3.5 Start-Up

When the voltage on the VIN pin exceeds the positive-going UVLO threshold, the device initializes as follows:

- The device pulls the EN pin low.
- The device enables the internal reference voltage.
- The device reads the state of the VSEL, FSEL and SYNC_OUT pins.
- The device loads the default values into the device registers.

When initialization is complete, the device enables I²C communication and releases the EN pin. The external circuitry controlling the EN pin now determines the behavior of the device:

- If the EN pin is low, the device is disabled: write to and read from the device registers, but the DC/DC converter does not operate.
- If the EN pin is high, the device is enabled: write to and read from the device registers and, after a short delay from EN pin going high, the DC/DC converter starts to ramp up the output.

Figure 8-7 shows the start-up sequence when the EN pin is pulled up to V_{IN}.

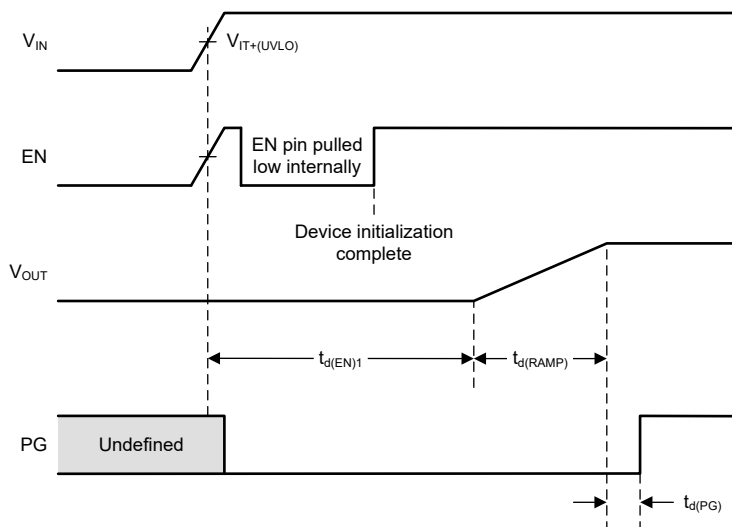

Figure 8-7. Start-Up Timing When EN is Pulled Up to V_{IN}

Figure 8-8 shows the start-up sequence when an external signal is connected to the EN pin.

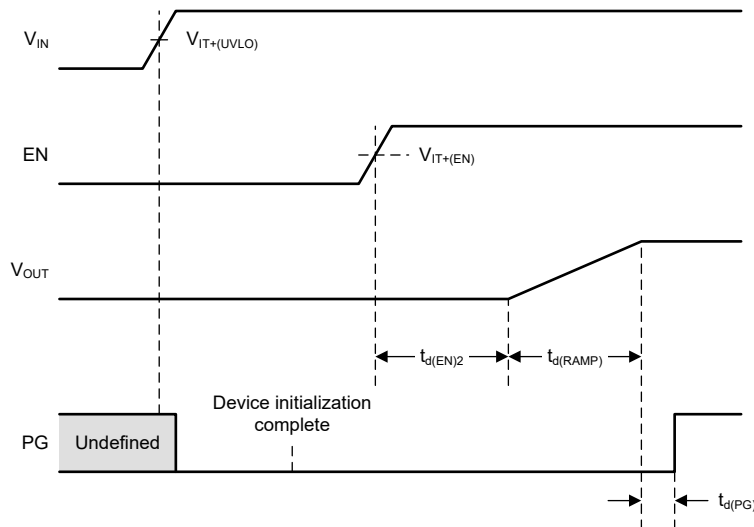

Figure 8-8. Start-Up Timing When an External Signal is Connected to the EN Pin

The SSTIME[1:0] bits in the CONTROL2 register select the duration of the soft-start ramp:

- $t_{d(RAMP)} = 500\mu s$
- $t_{d(RAMP)} = 770\mu s$
- $t_{d(RAMP)} = 1ms$
- $t_{d(RAMP)} = 2ms$

If the user programs the new output voltage setpoint (VSET[7:0]), output voltage range (VRANGE[1:0]), or soft-start time (SSTIME[1:0]) settings when the device has already begun the soft-start sequence, the device ignores the new values until the soft-start sequence is complete. For example, if the user changes the value of VSET[7:0] during soft start, the device first ramps to the value that VSET[7:0] had when the soft-start sequence began and then, when soft start is complete, ramps up or down to the new value.

The device can start up into a prebiased output. In this case, only a portion of the internal voltage ramp is seen externally (see Figure 8-9).

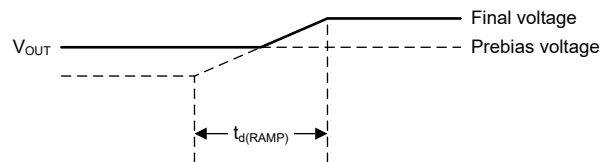

Figure 8-9. Start-Up into a Prebiased Output

Note that the device *always* operates in DCM/PFM allowed during the start-up ramp, regardless of other configuration settings or operating conditions.

8.3.6 Switching Frequency Selection

During device initialization, a resistor-to-digital converter in the device determines the state of the FSEL pin and sets the switching frequency of the DC/DC converter according to Table 8-2.

Table 8-2. Switching Frequency Options

RESISTOR AT FSEL (1%)	SWITCHING FREQUENCY
6.2kΩ to GND	1.5MHz
Short to GND	2.25MHz
Short to V _{IN}	2.5MHz
47kΩ to V _{IN}	3MHz

The following figure shows a simplified block diagram of the R2D converter used to detect the state of the FSEL pin (an identical circuit detects the state of the VSEL pin – see [Output Voltage Setpoint](#)).

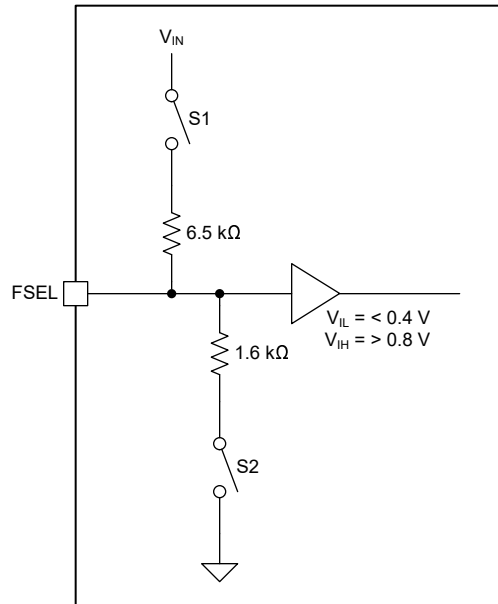

Figure 8-10. FSEL R2D Converter Functional Block Diagram

Detection of the state of the FSEL pin works as follows:

To detect the most significant bit (MSB), the circuit opens S1 and S2, and the input buffer detects if a high or a low level is connected to the FSEL pin.

To detect the least significant bit (LSB):

- If the MSB is 0, the circuit closes S1. If the input buffer detects a high level, the LSB = 1; if the circuit detects a low level, the LSB = 0.
- If the MSB is 1, the circuit closes S2. If the input buffer detects a low level, the LSB = 0; if the circuit detects a high level, the LSB = 1.

The propagation delay of the current-sensing comparator limits the minimum on-time of the device. In practice, this means that the maximum switching frequency the device can support decreases with small duty cycles. [Figure 6-5](#) shows the practical operating range of the device with 3.3-V and 5-V supplies.

8.3.7 Output Voltage Setting

8.3.7.1 Output Voltage Range

The device has three different voltage ranges. The VRANGE[1:0] bits in the CONTROL1 register control which range is active (see [Table 8-3](#)).

Table 8-3. Voltage Ranges

VRANGE[1:0]	VOLTAGE RANGE
0b00	0.4V to 0.71875V in 1.25mV steps
0b01	0.4V to 1.0375V in 2.5mV steps
0b10	0.4V to 1.675V in 5mV steps
0b11	0.4V to 1.675V in 5mV steps

Note that every change to the VRANGE[1:0] bits must be followed by a write to the VSET register – even if the value of the VSET[7:0] bits does not change. This sequence is necessary for the device to start to use the new voltage range.

8.3.7.2 Output Voltage Setpoint

Together with the selected range, the VSET[7:0] bits in the VSET register control the output voltage setpoint of the device (see [Table 8-4](#)).

Table 8-4. Start-Up Voltage Settings

VRANGE[1:0]	OUTPUT VOLTAGE SETPOINT
0b00	$0.4V + VSET[7:0] \times 1.25mV$
0b01	$0.4V + VSET[7:0] \times 2.5mV$
0b10	$0.4V + VSET[7:0] \times 5mV$
0b11	$0.4V + VSET[7:0] \times 5mV$

During initialization, the device reads the state of the VSEL pin and selects the default output voltage according to [Table 8-5](#). Note that the VSEL pin also selects the I²C target address of the device (see below). Please see the *Device Options* table for the complete list of device versions and the output voltage setpoint.

Table 8-5. Default Output Voltage Setpoints

VSEL PIN ¹	VSET[7:0]	I ² C DEVICE ADDRESS	OUTPUT VOLTAGE SETPOINT
6.2kΩ to GND	0x50	0x44	800mV
Short-Circuit to GND	0x46	0x45	750mV
Short-Circuit to V _{IN}	0x5F	0x46	875mV
47kΩ to V _{IN}	0x24	0x47	580mV

If you program new output voltage setpoint (VSET[7:0]), output voltage range (VRANGE[1:0]), or soft-start time (SSTIME[1:0]) settings when the device has already begun the soft-start sequence, the device ignores the new values until the soft-start sequence is complete. For example, if you change the value of VSET[7:0] during soft-start, the device first ramps to the value that VSET[7:0] had when the soft-start sequence began and then, when soft-start is complete, ramps up or down to the new value.

If the user changes VSET[7:0], VRAMP[1:0], or SSTIME[1:0] while EN is low, the device uses the new values the next time the user enables the device.

During start-up the output voltage ramps up to the target value set by the VSEL pin before ramping up or down to any new value programmed to the device over the I²C interface.

8.3.7.3 Non-Default Output Voltage Setpoint

If none of the default voltage range, voltage setpoint combinations are an excellent choice for the application, the user can change these device settings through I²C before enabling the device. Then, when pulling the EN pin high, the device starts up with the desired start-up voltage.

Note that if you change the device settings through I²C *while the device is ramping*, the device ignores the changes until the ramp is complete.

8.3.7.4 Dynamic Voltage Scaling

If you change the output voltage setpoint while the DC/DC converter is operating, the device ramps up or down to the new voltage setting in a controlled way.

The VRAMP[1:0] bits in the CONTROL1 register set the slew rate when the device ramps from one voltage to another during DVS (see [Table 8-6](#)).

¹ For reliable voltage setting, make sure that there is no stray current path connected to the VSEL pin and that the parasitic capacitance between the VSEL pin and GND is less than 30pF.

Table 8-6. Dynamic Voltage Scaling Slew Rate

VRAMP[1:0]	DVS SLEW RATE
0b00	10mV/μs
0b01	5mV/μs
0b10	1.25mV/μs
0b11	0.5mV/μs

Note that ramping the output to a higher voltage requires additional output current, so that during DVS the converter must generate a total output current given by:

$$I_{OUT} = I_{OUT(DC)} + C_{OUT} \frac{dV_{OUT}}{dt} \tag{2}$$

where:

- I_{OUT} is the total current the converter must generate while ramping to a higher voltage
- $I_{OUT(DC)}$ is the DC load current
- C_{OUT} is the total output capacitance
- dV_{OUT}/dt is the slew rate of the output voltage (programmable in the range 0.5mV/μs to 10mV/μs)

For correct operation, make sure that the total output current during DVS does not exceed the current limit of the device.

8.3.7.5 Droop Compensation

Droop compensation scales the nominal output voltage based on the output current. This action is done such that the output voltage is set to a higher value with no output current and to a lower value than the nominal value with the maximum output current. Droop compensation therefore provides a higher margin during a load transient and helps to keep the output voltage within a certain tolerance band in case of a heavy load step or at load release or allows to use a lower output capacitance. The voltage scaling is absolute instead of relative. The voltage scaling vs output current depends on the output current version of TPS6287x-Q1 based on the rated output current of , 15A, 20A, 25A and 30A, respectively. The behavior is shown in the graph in [Figure 8-11](#). See the [Device Options](#) table for the specific version if droop compensation is disabled or enabled by default. Droop compensation can be enabled by bit CONTROL3:DROOPEN. Enabling droop compensation must be done while the device is disabled otherwise a transient output voltage deviation can occur.

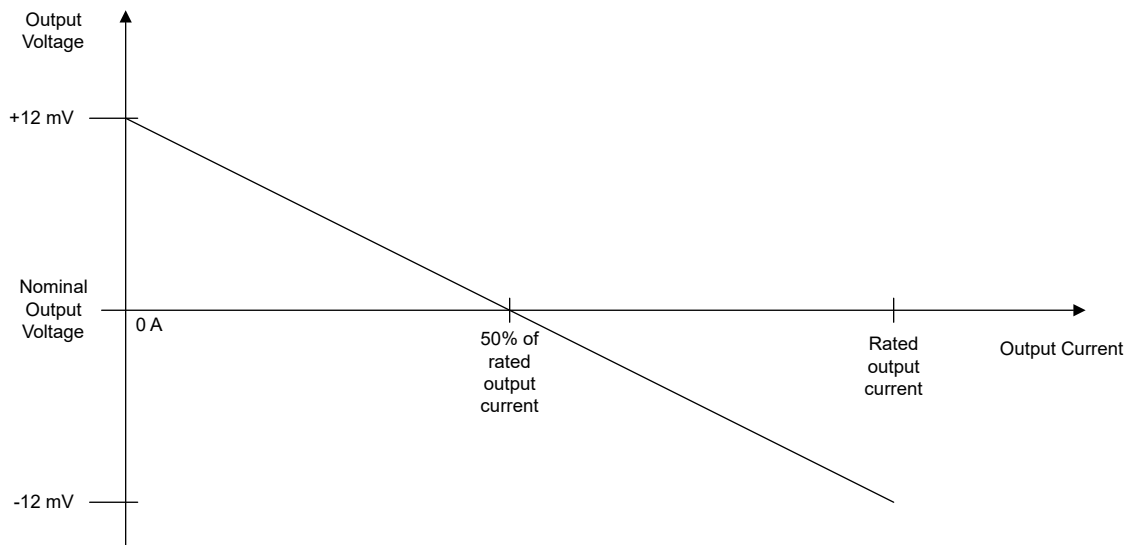

Figure 8-11. Voltage Scaling With Output Current

8.3.8 Compensation (COMP)

The COMP pin is the connection point for an external compensation network. A series-connected resistor and capacitor to AGND is sufficient for typical applications and provides enough scope to optimize the loop response for a wide range of operating conditions.

When using multiple devices in a stacked configuration, all devices share a common compensation network, and the COMP pin makes sure of equal current sharing between the devices (see [Section 8.3.18](#)).

8.3.9 Mode Selection / Clock Synchronization (MODE/SYNC)

A high level on the MODE/SYNC pin selects forced-PWM operation. A low level on the MODE/SYNC pin selects power-save operation, in which the device automatically transitions between PWM and PFM, according to the load conditions.

If you apply a valid clock signal to the MODE/SYNC pin, the device synchronizes the switching cycles to the external clock and automatically selects forced-PWM operation.

The MODE/SYNC pin is logically ORed with the FPWMEN bit in the CONTROL1 register (see [Table 8-1](#)).

When multiple devices are used together in a stacked configuration the MODE/SYNC pin of the secondary devices is the input for the clock signal (see [Section 8.3.18](#)).

8.3.10 Spread Spectrum Clocking (SSC)

The device has a spread spectrum clocking function that can reduce electromagnetic interference (EMI). When the SSC function is active, the device modulates the switching frequency $\pm 10\%$ about the nominal value. The frequency modulation has a triangular characteristic (see [Figure 8-12](#)).

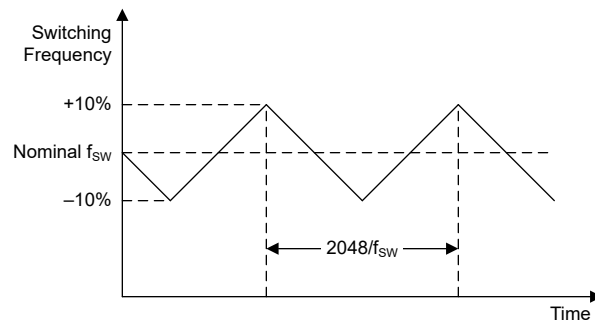

Figure 8-12. Spread Spectrum Clocking Behavior

To use the SSC function, make sure that:

- SSCEN = 1 in the CONTROL1 register
- Forced-PWM operation is selected (MODE pin is high or FPWMEN = 1 in the CONTROL1 register)
- The device is not synchronized to an external clock

To disable the SSC function, make sure that SCCEN = 0 in the CONTROL1 register.

To use the SSC function with multiple devices in a stacked configuration, make sure that the primary converter runs from the internal oscillator and synchronize all secondary converters to the primary clock (see [Figure 8-16](#)).

8.3.11 Output Discharge

The device has an output discharge function which makes sure of a defined ramp down of the output voltage when the device is disabled and keeps the output voltage close to 0V while the device is off. The output discharge function is enabled when DISCHEN = 1 in the CONTROL1 register. The output discharge function is enabled by default.

If enabled, the device discharges the output under the following conditions:

- A low level is applied to the EN pin

- SWEN = 0 in the CONTROL1 register
- A thermal shutdown event occurs
- An UVLO event occurs
- An OVLO event occurs

The output discharge function is not available until you have enabled the device at least once after power up. During power-down, the device continues to discharge the output for as long as the supply voltage is greater than approximately 1.8V.

8.3.12 Undervoltage Lockout (UVLO)

The TPS6287x-Q1 has an undervoltage lockout function that disables the device if the supply voltage is too low for correct operation. The negative-going threshold of the UVLO function is 2.5V (typical). If the supply voltage decreases below this value, the device stops switching and, if DISCHEN = 1 in the CONTROL1 register, turns on the output discharge.

8.3.13 Overvoltage Lockout (OVLO)

The TPS6287x-Q1 has an overvoltage lockout function that disables the DC/DC converter if the supply voltage is too high for correct operation. The positive-going threshold of the OVLO function is 6.3V (typical). If the supply voltage increases above this value, the device stops switching and, if DISCHEN = 1 in the CONTROL1 register, turns on the output discharge.

The device automatically starts switching again – the device begins a new soft-start sequence – when the supply voltage falls below 6.2V (typical).

8.3.14 Overcurrent Protection

8.3.14.1 Cycle-by-Cycle Current Limiting

If the peak inductor current increases above the high-side current limit threshold, the device turns off the high-side switch and turns on the low-side switch to ramp down the inductor current. The device only turns on the high-side switch again if the inductor current has decreased below the low-side current limit threshold.

Note that because of the propagation delay of the current limit comparator, the current limit threshold in practice can be greater than the DC value specified in the Electrical Characteristics. The current limit in practice is given by:

$$I_L = I_{LIMH} + \left(\frac{V_{IN} - V_{OUT}}{L} \right) t_{pd} \quad (3)$$

where:

- I_L is the peak inductor current
- I_{LIMH} is the high-side current limit threshold measured at DC
- V_{IN} is the input voltage
- V_{OUT} is the output voltage
- L is the effective inductance at the peak current level
- t_{pd} is the propagation delay of the current limit comparator (typically 50ns)

8.3.14.2 Hiccup Mode

To enable hiccup operation, make sure that HICCUPEN = 1 in the CONTROL1 register. The HICCUP function is disabled by default.

If hiccup operation is enabled and the high-side switch current exceeds the current limit threshold on 32 consecutive switching cycles, the device:

- Stops switching for 128μs, after which the device automatically starts switching again (starts a new soft-start sequence).

- Sets the HICCUP bit in the STATUS register.
- Pulls the PG pin low. The PG pin stays low until the overload condition goes away and the device can start up correctly and regulate the output voltage. Note that power-good function has a deglitch circuit, which delays the rising edge of the power-good signal by 40µs (typical).

Hiccup operation continues – in a repeating sequence of 32 cycles in current limit, followed by a pause of 128µs, followed by a soft-start attempt – for as long as the output overload condition exists.

The device clears the HICCUP bit if you read the STATUS register when the overload condition has been removed.

8.3.14.3 Current-Limit Mode

To enable current-limit mode, make sure that HICCUPEN = 0 in the CONTROL1 register.

When current limit operation is enabled, the device limits the high-side switch current cycle-by-cycle for as long as the overload condition exists. If the device limits the high-side switch current for four or more consecutive switching cycle, the device sets ILIM = 1 in the STATUS register.

The device clears the ILIM bit if the user reads the STATUS register when the overload condition no longer exists.

8.3.15 Power Good (PG)

The Power-Good (PG) pin is bidirectional and has two functions:

- In a standalone configuration, and in the primary device of a stacked configuration, the PG pin is an open-drain output that indicates the status of the converter or stack.
- In a secondary device of a stacked configuration, the PG pin is an input that indicates when the soft-start sequence is complete and all converters in the stack can change from DCM switching to CCM switching.

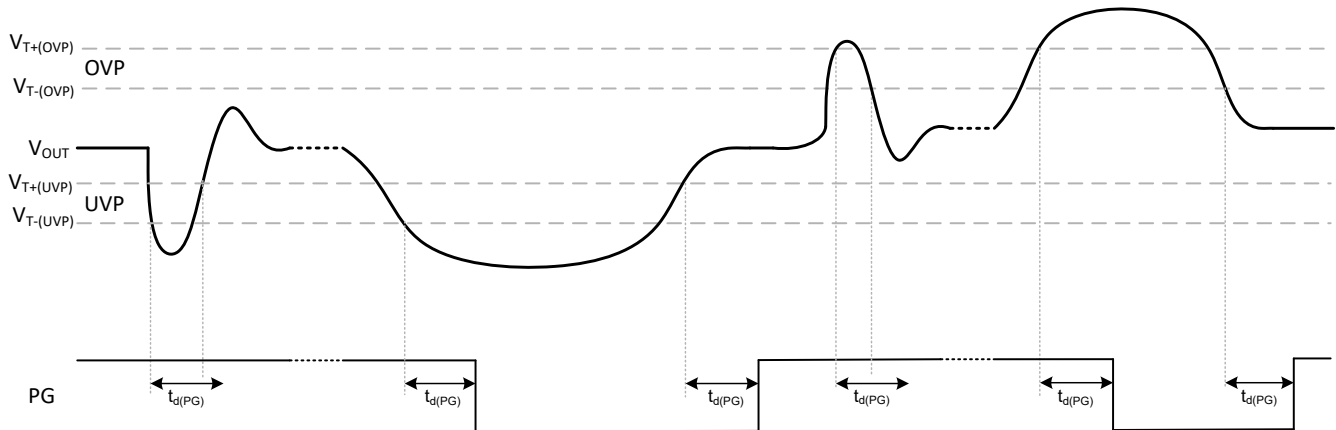

Figure 8-13. PG Timing

8.3.15.1 Standalone, Primary Device Behavior

The primary purpose of the PG pin is to indicate if the output voltage is in regulation, but the PG pin also indicates if the device is in thermal shutdown or disabled. Table 8-7 summarizes the behavior of the PG pin in a stand-alone or primary device.

Table 8-7. Power-Good Function Table

V _{IN}	EN	V _{OUT}	SOFT START	PGBLNKDVS AND DVS_active	T _J	PG
V _{IN} < 2V	X	X	X	X	X	Undefined
V _{IT-(UVLO)} ≥ V _{IN} ≥ 2V	X	X	X	X	X	Low

Table 8-7. Power-Good Function Table (continued)

V_{IN}	EN	V_{OUT}	SOFT START	PGBLNKDVS AND DVS_active	T_J	PG
$V_{IT-(UVLO)} < V_{IN} < V_{IT+(OVLO)}$	L	X	X	X	X	Low
	H	X	Active	X	X	Low
		$V_{OUT} > V_{T+(OVP)}$ or $V_{OUT} < V_{T-(UVP)}$	Inactive	0	X	low
		$V_{T-(OVP)} > V_{OUT} > V_{T+(UVP)}$	Inactive	1	$T_J < T_{SD}$	Hi-Z
		X	X	X	$T_J < T_{SD}$	Hi-Z
$V_{IN} > V_{IT+(OVLO)}$	X	X	X	X	$T_J > T_{SD}$	Low

Figure 8-14 shows a functional block diagram of the power-good function in a stand-alone or primary device. A window comparator monitors the output voltage, and the output of the comparator goes high if the output voltage is either less than 95% (typical) or greater than 105% (typical) of the nominal output voltage. The output of the window comparator is deglitched – the typical deglitch time is 40µs – and then used to drive the open-drain PG pin. The output of the window comparator is deglitched – the typical deglitch time is 40µs – and then used to drive the open-drain PG pin.

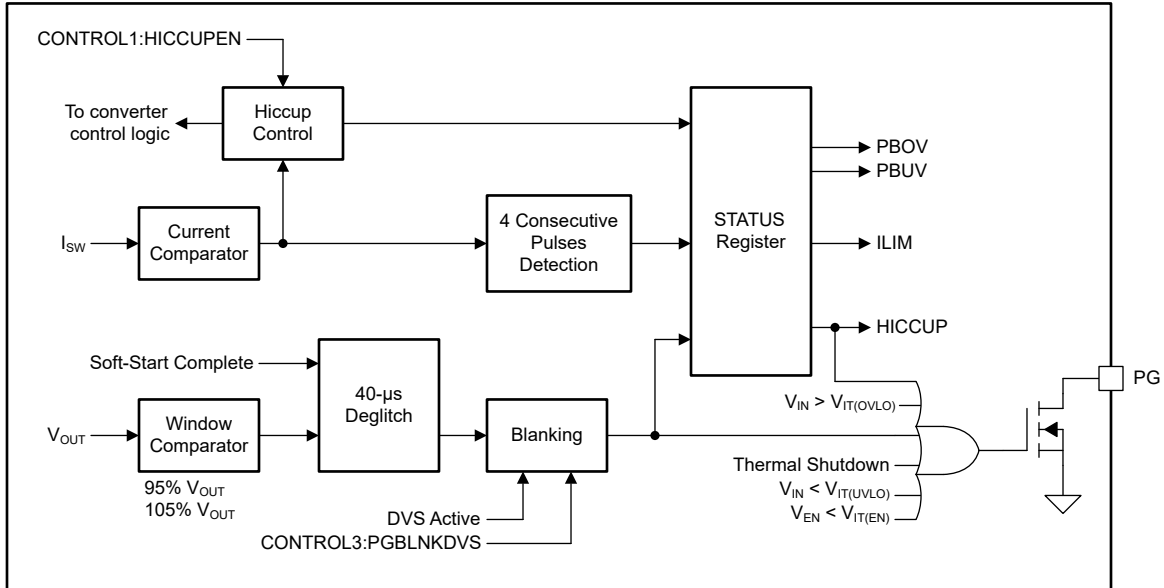

Figure 8-14. Power-Good Functional Block Diagram (Standalone / Primary Device)

During DVS activity, when the DC/DC converter transitions from one output voltage setting to another, the output voltage can temporarily exceed the limits of the window comparator and pull the PG pin low. The device has a feature to disable this behavior: if PGBLNKDVS = 1 in the CONTROL3 register, the device ignores the output of the power-good window comparator while DVS is active.

Note that the PG pin is always low – regardless of the output of the window comparator – when:

- The device is in thermal shutdown
- The device is disabled
- The device is in undervoltage lockout
- The device is in overvoltage lockout
- The device is in soft start
- The device is in HICCUP mode

8.3.15.2 Secondary Device Behavior

Figure 8-15 shows a functional block diagram of the power-good function in a secondary device. During initialization, the device presets FF2, which pulls down the PG pin and forces the devices in a stack to operate in DCM. When the device completes the internal start-up sequence, the device resets FF2, which turns off Q1. In a stacked configuration all devices share the same PG signal, and therefore the PG pin stays low until *all* devices in the stack have completed the start-up. When that happens, FF1 is set and the converters operate in CCM. FF1 and FF2 are preset such that DCM is allowed each time the converter is disabled, either by the EN pin, EN bit, thermal shutdown or UVLO.

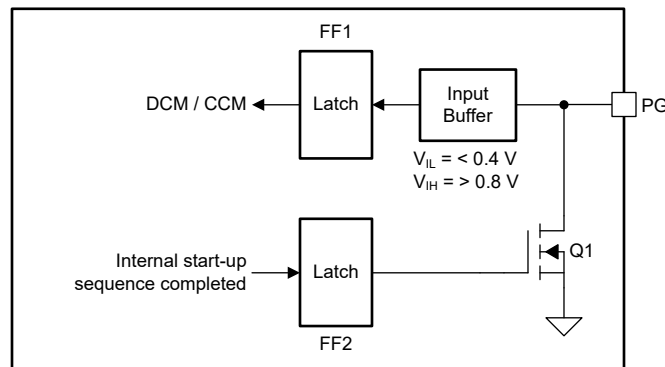

Figure 8-15. Power-Good Functional Block Diagram (Secondary Device)

8.3.16 Remote Sense

The device has two pins, VOSNS and GOSNS, to remotely sense the output voltage. Remote sensing lets the converter sense the output voltage directly at the point-of-load and increases the accuracy of the output voltage regulation.

In a stacked configuration, you must connect the VOSNS and GOSNS of the primary device directly at the point-of-load. For the secondary devices, you can connect the VOSNS and GOSNS pins to the local output capacitor or both pins to AGND (see Section 8.3.18).

8.3.17 Thermal Warning and Shutdown

The device has a two-level overtemperature detection function.

If the junction temperature rises above the thermal warning threshold of 150 °C (typical), the device sets the TWARN bit in the STATUS register. The device clears the TWARN bit if you read the STATUS register when the junction temperature is below the TWARN threshold of 130°C (typical).

If the junction temperature rises above the thermal shutdown threshold of 170°C (typical), the device:

- Stops switching
- Pulls down the EN pin (if SINGLE = 0 in the CONTROL3 register)
- Enables the output discharge (if DISCHEN = 1 in the CONTROL1 register)
- Sets the TSHUT bit in the STATUS register
- Pulls the PG pin low

If the junction temperature falls below the thermal shutdown threshold of 150°C (typical), the device:

- Starts switching again, starting with a new soft-start sequence
- Sets the EN pin to high impedance
- Sets the PG pin to high-impedance

The device clears the TSHUT bit if you read the STATUS register when the junction temperature is below the TSHUT threshold of 150°C (typical).

In a stacked configuration, in which all devices share a common enable signal, a thermal shutdown condition in one device disables the entire stack. When the hot device cools down, the whole stack automatically starts switching again.

8.3.18 Stacked Operation

Connect multiple TPS6287x-Q1 devices in parallel in what is known as a "stack"; for example, to increase output current capability or reduce device junction temperature. A stack comprises one *primary* device and one or more *secondary* devices. During initialization, each device monitors the SYNCOUT pin to determine if the device must operate as a primary device or a secondary device:

- If there is a 47kΩ resistor between the SYNCOUT pin and ground, the device operates as a secondary device
- If the SYNCOUT pin is high impedance, the device operates as a primary device

Figure 8-16 shows the recommended interconnections in a stack of two TPS6287x-Q1 devices.

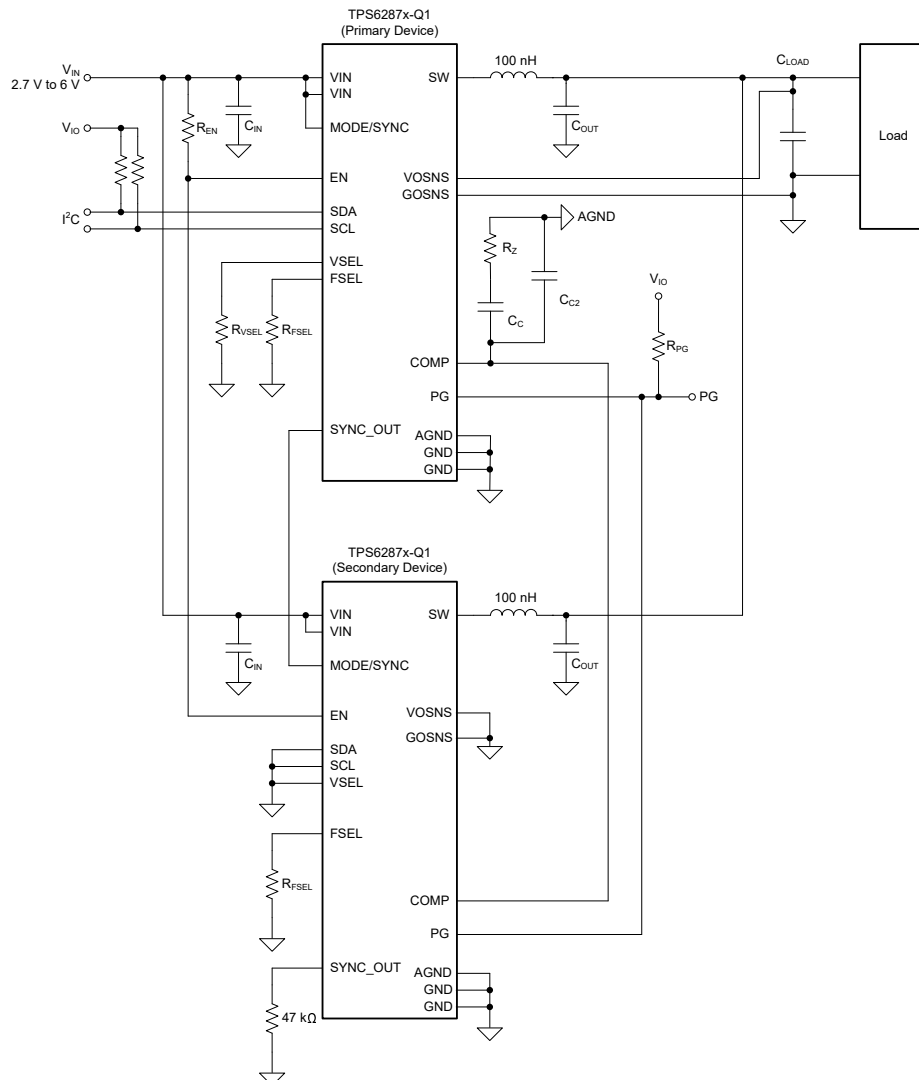

Figure 8-16. Two TPS6287x-Q1 Devices in a Stacked Configuration

The key points to note are:

- All the devices in the stack share a common enable signal, which must be pulled up with a resistance of at least 15kΩ.

- All the devices in the stack share a common power-good signal.
- All the devices in the stack share a common compensation signal.
- All secondary devices must connect a 47kΩ resistor between the SYNC_OUT pin and ground.
- The remote sense pins (VOSNS and GOSNS) of each device must be connected (do not leave these pins floating).
- VOSNS and GOSNS of the primary device must be connected to the capacitor at the load
- VOSNS and GOSNS of the secondary devices can either be connected to the output capacitor at the device or alternatively both pins can be tied to AGND.
- Each device must be configured for the same switching frequency.
- The primary device must be configured for forced-PWM operation (secondary devices are automatically configured for forced-PWM operation).
- A stacked configuration can support synchronization to an external clock or spread-spectrum clocking.
- Only the VSEL pin of the primary device is used to set the default output voltage. The VSEL pin of secondary devices is not used and must be connected to ground.
- The SDA and SCL pins of secondary devices are not used and must be connected to ground.
- A stacked configuration uses a daisy-chained clocking signal, in which each device switches with a phase offset of approximately 120° relative to the adjacent devices in the daisy-chain. To daisy-chain the clocking signal, connect the SYNCOUT pin of the primary device to the MODE/SYNC pin of the first secondary device. Connect the SYNCOUT pin of the first secondary device to the MODE/SYNC pin of the second secondary device. Continue this connection scheme for all devices in the stack, to daisy-chain them together.
- CONTROL2:SYNC_OUT_PHASE = 1 sets a phase shift of 180° from the primary to the first secondary device. Please see the DEVICE OPTIONS table for the complete list of available OTP spins.
- Hiccup overcurrent protection must not be used in a stacked configuration.

In a stacked configuration, the common enable signal also acts as a SYSTEM_READY signal (see [Section 8.3.4](#)). Each device in the stack can pull the EN pin low during device start-up or when a fault occurs. Thus, the stack is only enabled when all devices have completed the start-up sequence and are fault-free. A fault in any one device disables the whole stack for as long as the fault condition exists.

During start-up, the primary device pulls the COMP pin low for as long as the enable signal (SYSTEM_READY) is low. When the enable signal goes high, the primary device actively controls the COMP pin and all devices in the stack follow the COMP voltage. During start-up, each device in the stack pulls the PG pin low while the pin initializes. When initialization is complete, each secondary device in the stack sets the PG pin to a high impedance and the primary device alone controls the state of the PG signal. The PG pin goes high when the stack has completed the start-up ramp and the output voltage is within specification. The secondary devices in the stack detect the rising edge of the power-good signal and switch from DCM operation to CCM operation. After the stack has successfully started up, the primary device controls the power-good signal in the normal way. In a stacked configuration, there are some faults that only affect individual devices, and other faults that affect all devices. For example, if one device enters current limit, only that device is affected. But a thermal shutdown or undervoltage lockout event in one device disables all devices through the shared enable (SYSTEM_READY) signal.

Functionality During Stacked Operation

Some device features are not available during stacked operation, or are only available in the primary converter. [Table 8-8](#) summarizes the available functionality during stacked operation.

Table 8-8. Functionality During Stacked Operation

FUNCTION	PRIMARY DEVICE	SECONDARY DEVICE	REMARK
UVLO	Yes	Yes	Common enable signal
OVLO	Yes	Yes	Common enable signal
OCP – current limit	Yes	Yes	Individual
OCP – hiccup OCP	No	No	Do not use during stacked operation
Thermal shutdown	Yes	Yes	Common enable signal

Table 8-8. Functionality During Stacked Operation (continued)

FUNCTION	PRIMARY DEVICE	SECONDARY DEVICE	REMARK
Power-Good (window comparator)	Yes	No	Primary device only
I ² C Interface	Yes	No	Primary device only
DVS	Through I ² C	No	Voltage loop controlled by primary device only
SSC	Through I ² C	No	Daisy-chained from primary device to secondary devices
SYNC	Yes	Yes	Synchronization clock applied to primary device
Precise Enable	No	No	Only binary enable
Output Discharge	Yes	Yes	Always enabled in secondary devices

Fault Handling During Stacked Operation

In a stacked configuration, there are some faults that only affect individual devices, and other faults that affect all devices. For example, if one device enters current limit, only that device is affected. But a thermal shutdown or undervoltage lockout event in one device disables all devices through the shared enable (SYSTEM_READY) signal. [Table 8-9](#) summarizes the fault handling of the TPS6287x-Q1 devices during stacked operation.

Table 8-9. Fault Handling During Stacked Operation

FAULT CONDITION	DEVICE RESPONSE	SYSTEM RESPONSE
UVLO	Enable signal pulled low	New soft start
OVLO		
Thermal shutdown		
Current limit	Enable signal remains high	Error amplifier clamped
External CLK applied to MODE/SYNC fails	SYNC_OUT and power-stage switch to internal oscillator	System active but switching frequency is not synchronized if clk to a secondary device fails

8.4 Device Functional Modes

8.4.1 Power-On Reset

The device operates in POR mode when the supply voltage is less than the POR threshold.

In POR mode no functions are available and the content of the device registers is not valid.

The device leaves POR mode and enters UVLO mode when the supply voltage increases above the POR threshold.

8.4.2 Undervoltage Lockout

The device operates in UVLO mode when the supply voltage is between the POR and UVLO thresholds.

If the device enters UVLO mode from POR mode, no functions are available. If the device enters UVLO mode from Standby mode, the output discharge function is available. The content of the device registers is valid in UVLO mode.

The device leaves UVLO mode and enters POR mode when the supply voltage decreases below the POR threshold. The device leaves UVLO mode and enters Standby mode when the supply voltage increases above the UVLO threshold.

8.4.3 Standby

The device operates in standby mode when the supply voltage is greater than the UVLO threshold and the device has completed the initialization². Any of the following conditions is true:

- A low level is applied to the EN pin.
- SWEN = 0 in the CONTROL1 register.
- The device junction temperature is greater than the thermal shutdown threshold.
- The supply voltage is greater than the OVLO threshold.

The following functions are available in standby mode:

- I²C interface
- Output discharge
- Power good

The device leaves standby mode and enters UVLO mode when the supply voltage decreases below the UVLO threshold. The device leaves standby mode and enters on mode when all of the following conditions are true:

- A high-level is applied to the EN pin.
- SWEN = 1 in the CONTROL1 register.
- The device junction temperature is below the thermal shutdown threshold.
- The supply voltage is below the OVLO threshold.

8.4.4 On

The device operates in On mode when the supply voltage is greater than the UVLO threshold and all of the following conditions are true:

- A high-level is applied to the EN pin
- SWEN = 1 in the CONTROL1 register
- The device junction temperature is below the thermal shutdown threshold
- The supply voltage is below the OVLO threshold

All functions are available in On mode.

The device leaves On mode and enters UVLO mode when the supply voltage decreases below the UVLO threshold. The device leaves On mode and enters the Standby mode when any of the following conditions is true:

- A low level is applied to the EN pin
- SWEN = 0 in the CONTROL1 register
- The device junction temperature is greater than the thermal shutdown threshold
- The supply voltage is greater than the OVLO threshold

8.5 Programming

8.5.1 Serial Interface Description

I²C™ is a 2-wire serial interface developed by Philips Semiconductor, now NXP Semiconductors (see I²C-Bus Specification and User's Manual, Revision 6, 4 April 2014). The bus consists of a data line (SDA) and a clock line (SCL) with pull-up structures. When the bus is *idle*, both SDA and SCL lines are pulled high. All the I²C compatible devices connect to the I²C bus through open drain I/O pins, SDA and SCL. A controller, usually a microcontroller or a digital signal processor, controls the bus. The controller is responsible for generating the SCL signal and device addresses. The controller also generates specific conditions that indicate the START and STOP of data transfer. A target receives or transmits data on the bus under control of the controller.

The TPS6287x-Q1 device operates as a target and supports the following data transfer *modes*, as defined in the I²C-Bus Specification: standard mode (100kbps) and fast mode (400kbps) and fast mode plus (1Mbps). The

² The device initializes for 400 μs (typical) after the supply voltage increases above the UVLO threshold voltage following a device power-on reset (if the supply voltage decreases below the UVLO threshold but not below the POR threshold, the device does not reinitialize when the supply voltage increases again). During initialization the device reads the state of the VSEL, FSEL, and SYNC_OUT pins.

interface adds flexibility to the power supply design, enabling most functions to be programmed to new values depending on the instantaneous application requirements. Register contents remain intact as long as the input voltage remains above 1.4V.

The data transfer protocol for standard and fast modes is exactly the same, therefore the modes are referred to as F/S-mode in this document. The device supports 7-bit addressing; general call addresses are not supported. The device 7-bit address is selected by the status of pin VSEL (see [Table 8-5](#)).

The protocol for high-speed mode is different from F/S-mode and is referred to as HS-mode.

TI recommends that the I²C controller initiates a STOP condition on the I²C bus after the initial power up of SDA and SCL pullup voltages to make sure of reset of the I²C engine.

8.5.2 Standard-, Fast-, Fast-Mode Plus Protocol

The controller initiates data transfer by generating a start condition. The start condition is when a high-to-low transition occurs on the SDA line while SCL is high, as shown in [Figure 8-17](#). All I²C-compatible devices must recognize a start condition.

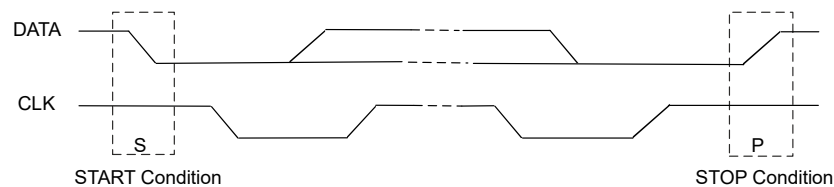

Figure 8-17. START and STOP Conditions

The controller then generates the SCL pulses, and transmits the 7-bit address and the read/write direction bit R/W on the SDA line. During all transmissions, the controller makes sure that data is valid. A valid data condition requires the SDA line to be stable during the entire high period of the clock pulse (see [Figure 8-18](#)). All devices recognize the address sent by the primary device and compare the address to the internal fixed addresses. Only the target with a matching address generates an acknowledge (see [Figure 8-19](#)) by pulling the SDA line low during the entire high period of the ninth SCL cycle. Upon detecting this acknowledge, the controller knows that the communication link with a target has been established.

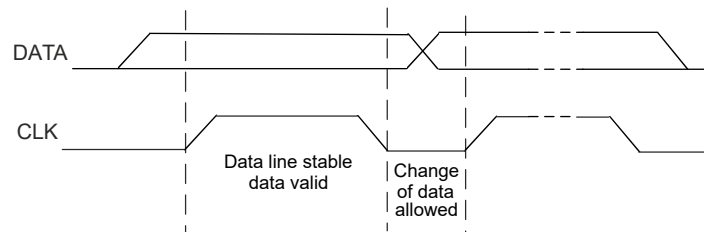

Figure 8-18. Bit Transfer on the Serial Interface

The controller generates further SCL cycles to either transmit data to the target (write command; $R/\bar{W} = 0$) or receive data from the target (read command; $R/\bar{W} = 1$). In either case, the receiver needs to acknowledge the data sent by the transmitter. So an acknowledge signal can either be generated by the controller or by the target, depending on which one is the receiver. 9-bit valid data sequences consisting of 8-bit data and 1-bit acknowledge can continue as long as necessary.

To signal the end of the data transfer, the controller generates a stop condition by pulling the SDA line from low to high while the SCL line is high (see [Figure 8-17](#)). This releases the bus and stops the communication link with the addressed target. All I²C compatible devices must recognize the stop condition. Upon the receipt of a stop condition, all devices know that the bus is released, and the devices wait for a start condition followed by a matching address.

Attempting to read data from register addresses not listed in this section results in 00h being read out.

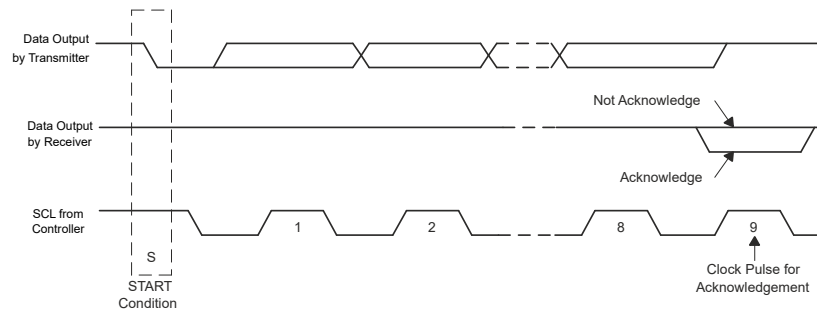

Figure 8-19. Acknowledge on the I²C Bus

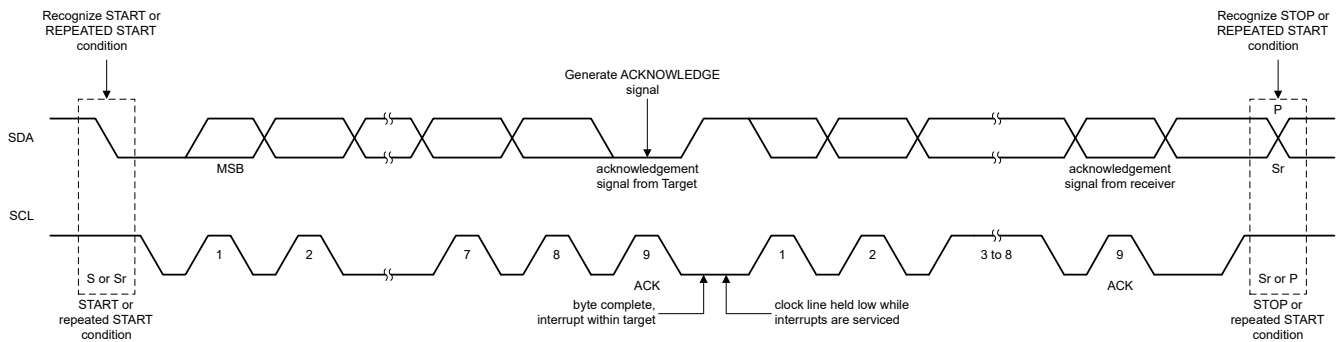

Figure 8-20. Bus Protocol

8.5.3 HS-Mode Protocol

The controller generates a start condition followed by a valid serial byte containing HS controller code 00001XXX. This transmission is made in F/S-mode at no more than 400Kbps. No device is allowed to acknowledge the HS controller code, but all devices must recognize the code and switch the internal setting to support 3.4Mbps operation.

The controller then generates a *repeated start condition* (a repeated start condition has the same timing as the start condition). After this repeated start condition, the protocol is the same as F/S-mode, except that transmission speeds up to 3.4Mbps are allowed. A stop condition ends the HS-mode and switches all the internal settings of the target devices to support the F/S-mode. Instead of using a stop condition, repeated start conditions must be used to secure the bus in HS-mode.

Attempting to read data from register addresses not listed in this section results in 00h being read out.

8.5.4 I²C Update Sequence

This requires a start condition, a valid I²C address, a register address byte, and a data byte for a single update. After the receipt of each byte, device acknowledges by pulling the SDA line low during the high period of a single clock pulse. A valid I²C address selects the device. The device performs an update on the falling edge of the acknowledge signal that follows the LSB byte.

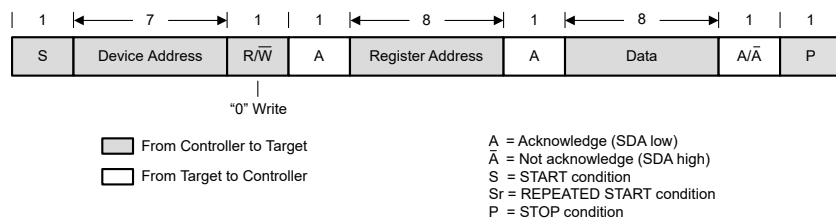

Figure 8-21. : "Write" Data Transfer Format in Standard-, Fast, Fast-Plus Modes

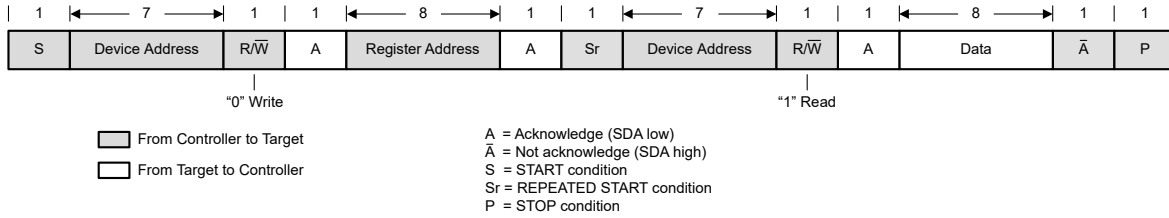

Figure 8-22. “Read” Data Transfer Format in Standard-, Fast, Fast-Plus Modes

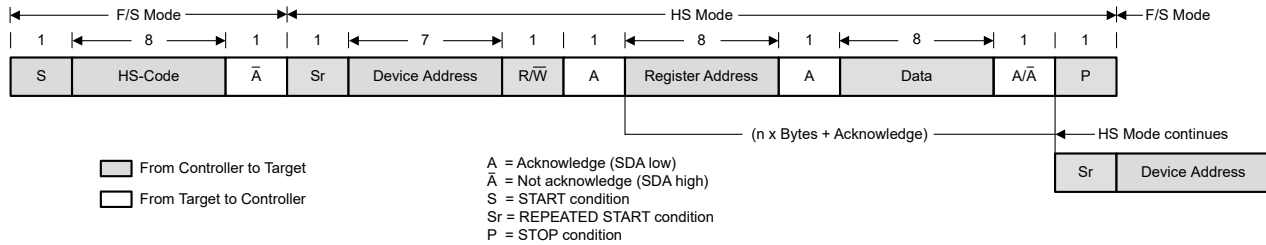

Figure 8-23. Data Transfer Format in HS-Mode

8.5.5 I²C Register Reset

The I²C registers can be reset by:

- pulling the input voltage below 1.4V (typical).
- or setting the Reset bit in the CONTROL register. When Reset is set to 1, all registers are reset to the default values and a new startup is begun immediately. After t_{Delay} , the I²C registers can be programmed again.

8.5.6 Dynamic Voltage Scaling (DVS)

To optimize the power consumption of the system, the output voltage of the TPS6287x-Q1 can be adapted during operation based on the actual power requirement of the load.

The device starts up into the default output voltage selected through the external VSEL pin or the settings in the VSET register. The output voltage can be dynamically adapted through the I²C interface by writing the new target output voltage to the VSET register. The output voltage then increases or decrease to the desired value with the voltage ramp speed defined in the CONTROL1 register.

Switching between different output voltage ranges

TPS6287x-Q1 devices offer three different output voltages ranges as defined in the CONTROL2 register. To change the output voltage range of TPS6287x-Q1, first step to the closest output voltage value within the currently used range, then change the VRANGE bit in the CONTROL2 register to the next VRANGE setting. After that set the target output voltage in the VSET register.

Note that a change in the output voltage range always must be followed by writing to the VSET Register, even though the output voltage does not change. The code in the VSET register must be updated to the correct value in the new range.

9 Device Registers

Table 9-1 lists the memory-mapped registers for the Device registers. All register offset addresses not listed in Table 9-1 should be considered as reserved locations and the register contents should not be modified.

Table 9-1. DEVICE Registers

Address	Acronym	Register Name	Section
0h	VSET	Output Voltage Setpoint	Section 9.1
1h	CONTROL1	Control 1	Section 9.2
2h	CONTROL2	Control 2	Section 9.3
3h	CONTROL3	Control 3	Section 9.4
4h	STATUS	Status	Section 9.5

Complex bit access types are encoded to fit into small table cells. Table 9-2 shows the codes that are used for access types in this section.

Table 9-2. Device Access Type Codes

Access Type	Code	Description
Read Type		
R	R	Read
Write Type		
W	W	Write
Reset or Default Value		
-n		Value after reset or the default value

9.1 VSET Register (Address = 0h) [Reset = XXh]

VSET is shown in [Table 9-3](#).

Return to the [Summary Table](#).

This register controls the output voltage setpoint

Table 9-3. VSET Register Field Descriptions

Bit	Field	Type	Reset	Description
7-0	VSET	R/W	xxxxxxxb	Output voltage setpoint (see also the range-setting bits in the CONTROL2 register). Range 1: Output voltage setpoint = 0.4 V + VSET[7:0] × 1.25 mV Range 2: Output voltage setpoint = 0.4 V + VSET[7:0] × 2.5 mV Range 3: Output voltage setpoint = 0.4 V + VSET[7:0] × 5 mV The state of the VSEL pin during power up determines the reset value.

9.2 CONTROL1 Register (Address = 1h) [Reset = X8h]

CONTROL1 is shown in [Table 9-4](#).

Return to the [Summary Table](#).

This register controls various device configuration options

Table 9-4. CONTROL1 Register Field Descriptions

Bit	Field	Type	Reset	Description
7	RESET	R/W	0b	Reset device. 0b = No effect 1b = The device is powered down, the pin status is read and all registers are reset to their default value. The device is then powered up again starting with a soft-start cycle. Reading this bit always returns 0.
6	SSCEN	R/W	xb	Spread spectrum clocking enable. Please see the DEVICE OPTIONS table if SSC is enabled by default. 0b = SSC operation disabled 1b = SSC operation enabled
5	SWEN	R/W	1b	Software enable. 0b = Switching disabled (register values retained) 1b = Switching enabled (without the enable delay)
4	FPWMEN	R/W	0b	Forced-PWM enable. 0b = Power-save operation enabled 1b = Forced-PWM operation enabled This bit is logically ORed with the MODE/SYNC pin: If a high level or a synchronization clock is applied to the the MODE/SYNC pin, the device operates in Forced-PWM, regardless of the state of this bit.
3	DISCHEN	R/W	1b	Output discharge enable. 0b = Output discharge disabled. 1b = Output discharge enabled.
2	HICCUPEN	R/W	0b	Hiccup operation enable. 0b = Hiccup operation disabled 1b = Hiccup operation enabled. Do not enable Hiccup operation during stacked operation
1-0	VRAMP	R/W	00b	Output voltage ramp speed when changing from one output voltage setting to another. 00b = 10 mV/μs 01b = 5 mV/μs 10b = 1.25 mV/μs 11b = 0.5 mV/μs

9.3 CONTROL2 Register (Address = 2h) [Reset = XXh]

CONTROL2 is shown in [Table 9-5](#).

Return to the [Summary Table](#).

This register controls various device configuration options

Table 9-5. CONTROL2 Register Field Descriptions

Bit	Field	Type	Reset	Description
7-5	RESERVED	R/W	000b	Reserved for future use. To ensure compatibility with future device variants, program these bits to 0.
4	SYNC_OUT_PHASE	R/W	xb	Phase shift of SYNC_OUT with reference to internal clk or external clk applied at MODE/SYNC. Please see the DEVICE OPTIONS table for the default value. 0b = SYNC_OUT is phase shifted by 120° 1b = SYNC_OUT is phase shifted by 180° The phase relation of 180° is only valid from the primary to the first secondary converter.
3-2	VRANGE	R/W	10b	Output voltage range. 00b = 0.4 V to 0.71875 V in 1.25-mV steps 01b = 0.4 V to 1.0375 V in 2.5-mV steps 10b = 0.4 V to 1.675 V in 5-mV steps 11b = 0.4 V to 1.675 V in 5-mV steps
1-0	SSTIME	R/W	xxb	Soft-start ramp time. Please see the DEVICE OPTIONS table for the default value. 00b = 0.5 ms 01b = 0.77 ms 10b = 1 ms 11b = 2 ms

9.4 CONTROL3 Register (Address = 3h) [Reset = 0Xh]

CONTROL3 is shown in [Table 9-6](#).

Return to the [Summary Table](#).

This register controls various device configuration options

Table 9-6. CONTROL3 Register Field Descriptions

Bit	Field	Type	Reset	Description
7-3	RESERVED	R/W	00000b	Reserved for future use. To ensure compatibility with future device variants, program these bits to 0.
2	DROOPEN	R/W	xb	Droop compensation enable. Please see the DEVICE OPTIONS table if droop compensation is enabled by default. 0b = droop compensation disabled 1b = droop compensation enabled
1	SINGLE	R/W	0b	Single operation. This bit controls the internal EN pulldown and SYNCOUT functions. 0b = EN pin pulldown and SYNCOUT enabled 1b = EN pin pulldown and SYNCOUT disabled. Do not set during stacked operation
0	PGBLNKDVS	R/W	0b	Power-good blanking during DVS. 0b = PG pin reflects the output of the window comparator 1b = PG pin is high impedance during DVS

9.5 STATUS Register (Address = 4h) [Reset = 00h]

STATUS is shown in [Table 9-7](#).

Return to the [Summary Table](#).

This register returns the device status flags

Table 9-7. STATUS Register Field Descriptions

Bit	Field	Type	Reset	Description
7-6	RESERVED	R	00b	Reserved for future use. To ensure compatibility with future device variants, ignore these bits.
5	HICCUP	R	0b	Hiccup. This bit reports whether a hiccup event occurred since the last time the STATUS register was read. 0b = No hiccup event occurred 1b = A hiccup event occurred
4	ILIM	R	0b	Current limit. This bit reports whether an current limit event occurred since the last time the STATUS register was read. 0b = No current limit event occurred 1b = An current limit event occurred
3	TWARN	R	0b	Thermal warning. This bit reports whether a thermal warning event occurred since the last time the STATUS register was read. 0b = No thermal warning event occurred 1b = A thermal warning event occurred
2	TSHUT	R	0b	Thermal shutdown. This bit reports whether a thermal shutdown event occurred since the last time the STATUS register was read. 0b = No thermal shutdown event occurred 1b = A thermal shutdown event occurred
1	PBUV	R	0b	Power-bad undervoltage. This bit reports whether a power-bad event (output voltage too low) occurred since the last time the STATUS register was read. 0b = No power-bad undervoltage event occurred 1b = A power-bad undervoltage event occurred
0	PBOV	R	0b	Power-bad overvoltage. This bit reports whether a power-bad event (output voltage too high) occurred since the last time the STATUS register was read. 0b = No power-bad overvoltage event occurred 1b = A power-bad overvoltage event occurred

10 Application and Implementation

Note

Information in the following applications sections is not part of the TI component specification, and TI does not warrant its accuracy or completeness. TI's customers are responsible for determining suitability of components for their purposes, as well as validating and testing their design implementation to confirm system functionality.

10.1 Application Information

The following section discusses selection of the external components to complete the power supply design for a typical application.

10.2 Typical Application

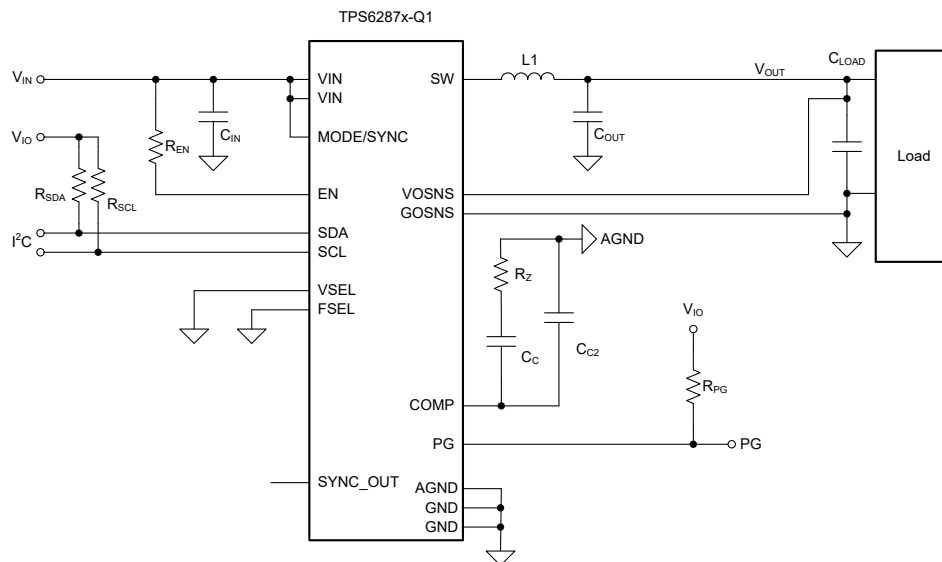

Figure 10-1. Typical Application Schematic

10.2.1 Design Requirements

Table 10-1 lists the operating parameters for this application example.

Table 10-1. Design Parameters

SYMBOL	PARAMETER	VALUE
V_{IN}	Input voltage	3.3V
V_{OUT}	Output voltage	0.75V
$TOL_{V_{OUT}}$	Output voltage tolerance allowed by the application	$\pm 3.3\%$
TOL_{DC}	Output voltage tolerance of the TPS6287x-Q1 (DC accuracy)	$\pm 0.8\%$
ΔI_{OUT}	Output current load step	$\pm 7.5A$
t_r	Load step rise time	1 μs
t_f	Load step fall time	1 μs
f_{SW}	Switching frequency	2.25MHz
L	Inductance	80nH
g_m	Error amplifier transconductance	1.5mS

Table 10-1. Design Parameters (continued)

SYMBOL	PARAMETER	VALUE
τ	Emulated current time constant	12.5 μ s
k_{BW}	Ratio of switching frequency to converter bandwidth (must be ≥ 4)	4
k_{COUT}	Ratio of minimum to maximum output capacitance (typically 2)	2
R_{PG}	Pullup resistor on power-good output	10k Ω
R_{EN}	Pullup resistor on enable	22k Ω
R_{SCL}, R_{SDA}	Pullup resistors on SDA and SCL	680 Ω

Preliminary Calculations

With a total allowable output voltage tolerance of $\pm 3.3\%$ and a maximum DC error of $\pm 0.8\%$, the allowable output voltage tolerance during a load step is given by:

$$\Delta V_{OUT} = \pm V_{OUT} \times (TOL_{V_{OUT}} - TOL_{DC}) \quad (4)$$

$$\Delta V_{OUT} = \pm 0.75 \times (0.033 - 0.008) = \pm 18.75 \text{ mV} \quad (5)$$

10.2.2 Detailed Design Procedure

The following subsections describe how to calculate the external components required to meet the specified transient requirements of a given application. The calculations include the worst-case variation of components and use the RMS method to combine the variation of uncorrelated parameters.

10.2.2.1 Inductor Selection

The TPS6287x-Q1 devices have been optimized for inductors in the range 42nH to 200nH. If the transient response of the converter is limited by the slew rate of the current in the inductor, using a smaller inductor can improve performance. However, the output ripple current increases as the value of the inductor decreases, and higher output current ripple generates higher output voltage ripple, which adds to the transient over or undershoot. The optimum configuration for a given application is a trade-off between a number of parameters. TI recommends a starting value of 60nH to 80nH for typical applications.

The inductor ripple current is given by:

$$I_{L(PP)} = \frac{V_{OUT}}{V_{IN}} \left(\frac{V_{IN} - V_{OUT}}{L \times f_{sw}} \right) \quad (6)$$

$$I_{L(PP)} = \frac{0.75}{3.3} \left(\frac{3.3 - 0.75}{80 \times 10^{-9} \times 2.25 \times 10^6} \right) \text{ A} = 3.22 \text{ A} \quad (7)$$

The following table lists a number of inductors designed for use with this application. This list is not exhaustive, however, and other inductors from other manufacturers can also be an excellent choice.

Table 10-2. Typical Inductors

PART NUMBER	INDUCTANCE [μ H]	CURRENT [A]	DC RESISTANCE	NOTES	DIMENSIONS [LxWxH] mm	MANUFACTURER
IHSR2525CZ-5A	0.056 μ H	45	0.38m Ω	For $f \geq 2.25$ MHz	6.65 \times 6.65 \times 3	Vishay
XEL4030-101ME	0.10 μ H	22	1.5m Ω	For $f \geq 1.5$ MHz	4 \times 4 \times 3.2	Coilcraft
744302010	0.105 μ H	30	0.235m Ω	For $f \geq 1.5$ MHz	7 \times 7 \times 4.8	Würth
XGL5030-161ME	0.16 μ H	25	1.3m Ω	For $f \geq 1.5$ MHz	5.3 \times 5.5 \times 3	Coilcraft
744300006	0.06 μ H	37	0.22m Ω	For $f \geq 2.25$ MHz	8.64 \times 6.35 \times 4.5	Würth
CLT32-55N	0.055 μ H	28	1m Ω	For $f \geq 2.25$ MHz	2.5 \times 3.2 \times 2.5	TDK

Table 10-2. Typical Inductors (continued)

PART NUMBER	INDUCTANCE [μ H]	CURRENT [A]	DC RESISTANCE	NOTES	DIMENSIONS [LxWxH] mm	MANUFACTURER
CLT32-42N	0.042 μ H	28	1m Ω	For $f \geq 2.25$ MHz	2.5 × 3.2 × 2.5	TDK
HPL505032F1060MRD3P	0.06 μ H	34	0.7m Ω	For $f \geq 2.25$ MHz	5 × 5 × 3.2	TDK
HPL505028F080MRD3P	0.08 μ H	34	0.8m Ω	For $f \geq 2.25$ MHz	5 × 5 × 3.2	TDK

10.2.2.2 Selecting the Input Capacitors

As with all buck converters, the input current of the TPS6287x-Q1 devices is discontinuous. The input capacitors provide a low-impedance energy source for the device, and the value, type, and location are critical for correct operation. TI recommends low-ESR multilayer ceramic capacitors for best performance. In practice, the total input capacitance typically comprises a combination of different capacitors, in which larger capacitors provide the decoupling at lower frequencies and smaller capacitors provide the decoupling at higher frequencies.

The TPS6287x-Q1 devices feature a *butterfly* layout with two VIN pin pairs on opposite sides of the package. This allows the input capacitors to be placed symmetrically on the PCB such that the electromagnetic fields generated cancel each other out, thereby reducing EMI.

The duty cycle of the converter is given by:

$$D = \frac{V_{OUT}}{\eta \times V_{IN}} \quad (8)$$

where:

- V_{IN} is the input voltage
- V_{OUT} is the output voltage
- η is the efficiency

$$D = \frac{0.75}{0.9 \times 3.3} = 0.253 \quad (9)$$

The value of input capacitance needed to meet the input voltage ripple requirements is given by:

$$C_{IN} = \frac{D \times (1 - D) \times I_{OUT}}{V_{IN(PP)} \times f_{sw}} \quad (10)$$

where:

- D is the duty cycle
- f_{sw} is the switching frequency
- $V_{IN(PP)}$ is the input voltage ripple
- I_{OUT} is the output current

$$C_{IN} = \frac{0.253 \times (1 - 0.253) \times 11.3}{0.1 \times 2.25 \times 10^6} \text{ F} = 9.5 \text{ } \mu\text{F} \quad (11)$$

The value of C_{IN} calculated with [Equation 10](#) is the *effective* capacitance after all derating, tolerance, and aging effects have been considered. We recommend multilayer ceramic capacitors with an X7R dielectric (or similar) for C_{IN} , and these capacitors must be placed as close to the VIN and GND pins as possible, so as to minimize the loop area.

[Table 10-3](#) lists a number of capacitors that are an excellent choice for this application. This list is not exhaustive, however, and other capacitors from other manufacturers can also be an excellent choice.

Table 10-3. List of Recommended Input Capacitors

CAPACITANCE	DIMENSIONS	VOLTAGE RATING	MANUFACTURER, PART NUMBER
	mm (inch)		
470nF ±10%	1005 (0402)	10V	Murata, GCM155C71A474KE36D
470nF ±10%	1005 (0402)	10V	TDK, CGA2B3X7S1A474K050BB
10µF ±10%	2012 (0805)	10V	Murata, GCM21BR71A106KE22L
10µF ±10%	2012 (0805)	10V	TDK, CGA4J3X7S1A106K125AB
22µF ±10%	3216 (1206)	10V	Murata, GCM31CR71A226KE02L
22µF ±20%	3216 (1206)	10V	TDK, CGA5L1X7S1A226M160AC

10.2.2.3 Selecting the Compensation Resistor

Use Equation 12 to calculate the recommended value of compensation resistor R_Z :

$$R_Z = \frac{1}{g_m} \left(\frac{\pi \times \Delta I_{OUT} \times L}{4 \times \tau \times \Delta V_{OUT}} \right) (1 + TOL_{IND}) \quad (12)$$

$$R_Z = \frac{1}{1.5 \times 10^{-3}} \left(\frac{\pi \times 7.5 \times 80 \times 10^{-9}}{4 \times 12.5 \times 10^{-6} \times 18.75 \times 10^{-3}} \right) (1 + 0.2) \Omega = 1.61 \text{ k}\Omega \quad (13)$$

Rounding up, the closest standard value from the E24 series is 1.8kΩ.

10.2.2.4 Selecting the Output Capacitors

In practice, the total output capacitance typically comprises a combination of different capacitors, in which larger capacitors provide the load current at lower frequencies and smaller capacitors provide the load current at higher frequencies. The value, type, and location of the output capacitors are critical for correct operation. TI recommends low-ESR multilayer ceramic capacitors with an X7R dielectric (or similar) for best performance.

The TPS6287x-Q1 devices feature a butterfly layout with two GND pins on opposite sides of the package. This feature allows the output capacitors to be placed symmetrically on the PCB such that the electromagnetic fields generated cancel each other out, thereby reducing EMI.

The transient response of the converter is defined by one of two criteria:

- The loop bandwidth, which must be at least 4 times smaller than the switching frequency.
- The slew rate of the current through the inductor and the output capacitance.

In typical low-output-voltage application, this is limited by the value of the output voltage and the inductors.

Which of the above criteria applies in any given application depends on the operating conditions and component values used. We therefore recommend calculating the output capacitance for both cases, and selecting the higher of the two values.

If the converter remains in regulation, the minimum output capacitance required is given by:

$$C_{OUT(min)(reg)} = \left(\frac{\tau \times g_m \times R_Z}{2 \times \pi \times L \times \frac{f_{SW}}{4}} \right) \left(1 + \sqrt{TOL_{IND}^2 + TOL_{fSW}^2} \right) \quad (14)$$

$$C_{OUT(min)(reg)} = \left(\frac{12.5 \times 10^{-6} \times 1.5 \times 10^{-3} \times 1.8 \times 10^3}{2 \times \pi \times 80 \times 10^{-9} \times \frac{2.25 \times 10^6}{4}} \right) \left(1 + \sqrt{20\%^2 + 10\%^2} \right) F = 146 \mu F \quad (15)$$

If the converter loop saturates, the minimum output capacitance is given by:

$$C_{OUT(min)}(sat) = \frac{1}{\Delta V_{OUT}} \left(\frac{L \times \left(\Delta I_{OUT} + \frac{I_{L(PP)}}{2} \right)^2}{2 \times V_{OUT}} - \frac{\Delta I_{OUT} \times t_t}{2} \right) (1 + TOL_{IND}) \quad (16)$$

$$C_{OUT(min)}(sat) = \frac{1}{18.75 \times 10^{-3}} \left(\frac{80 \times 10^{-9} \times \left(7.5 + \frac{3.22}{2} \right)^2}{2 \times 0.75} - \frac{7.5 \times 1 \times 10^{-6}}{2} \right) (1 + 20\%) F = 43 \mu F \quad (17)$$

In this case, choose $C_{OUT(min)} = 146\mu F$, as the larger of the two values, for the output capacitance.

When calculating worst-case component values, use the value calculated above as the *minimum* output capacitance required. For ceramic capacitors, the *nominal* capacitance when considering tolerance, DC bias, temperature, and aging effects is typically two times the minimum capacitance. In this case, the nominal capacitance is thus $292\mu F$.

Table 10-4. List of Recommended Output Capacitors

CAPACITANCE	DIMENSIONS	VOLTAGE RATING	MANUFACTURER, PART NUMBER
	mm (inch)		
22 μF $\pm 20\%$	2012 (0805)	6.3V	TDK, CGA4J1X7T0J226M125AC
22 μF $\pm 10\%$	2012 (0805)	6.3V	Murata, GCM31CR71A226KE02
47 μF $\pm 20\%$	3216 (1206)	4V	TDK, CGA5L1X7T0G476M160AC
47 μF $\pm 20\%$	3225 (1210)	6.3V	Murata, GCM32ER70J476ME19
100 μF $\pm 20\%$	3225 (1210)	4V	TDK, CGA6P1X7T0G107M250AC
100 μF $\pm 20\%$	3216 (1210)	6.3V	Murata, GRT32EC70J107ME13

10.2.2.5 Selecting the Compensation Capacitor C_C

First, use [Equation 18](#) to calculate the bandwidth of the loop:

$$BW = \frac{\tau \times g_m \times R_Z}{2 \times \pi \times L \times C_{OUT,min} \times k_{COUT}} \quad (18)$$

$$BW = \frac{12.5 \times 10^{-6} \times 1.5 \times 10^{-3} \times 1.8 \times 10^3}{2 \times \pi \times 80 \times 10^{-9} \times 146 \times 10^{-6} \times 2} = 230kHz \quad (19)$$

Use [Equation 20](#) to calculate the recommended value of C_C .

$$C_C = \frac{k_{BW}}{2 \times \pi \times BW \times R_Z} \quad (20)$$

$$C_C = \frac{4}{2 \times \pi \times 230 \times 10^3 \times 1.8 \times 10^3} = 1.54 nF \quad (21)$$

The closest standard value from the E12 series is 1.5nF.

10.2.2.6 Selecting the Compensation Capacitor C_{C2}

The compensation capacitor C_{C2} is an optional capacitor that TI recommends to include to bypass high-frequency noise from the COMP pin. The value of this capacitor is not critical; 10pF or 22pF capacitors are an excellent choice for typical applications.

10.2.3 Application Curves

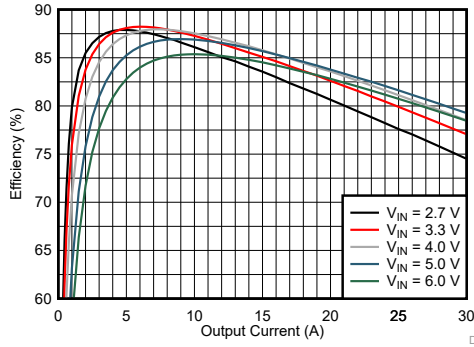

$V_{OUT} = 0.58V$ PWM $T_A = 25^\circ C$

Figure 10-2. Efficiency vs Output Current

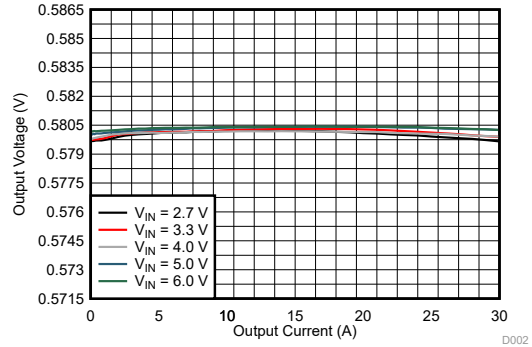

$V_{OUT} = 0.58V$ PWM; droop disabled $T_A = 25^\circ C$

Figure 10-3. Output Voltage vs Output Current

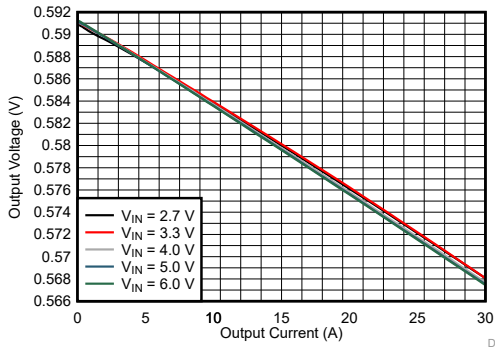

$V_{OUT} = 0.58V$ PWM; TPS62877 droop enabled $T_A = 25^\circ C$

Figure 10-4. Output Voltage vs Output Current

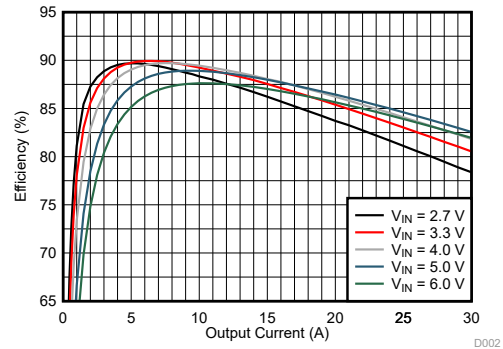

$V_{OUT} = 0.75V$ PWM $T_A = 25^\circ C$

Figure 10-5. Efficiency vs Output Current

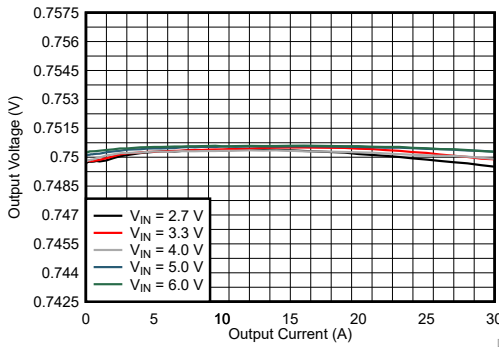

$V_{OUT} = 0.75V$ PWM; droop disabled $T_A = 25^\circ C$

Figure 10-6. Output Voltage vs Output Current

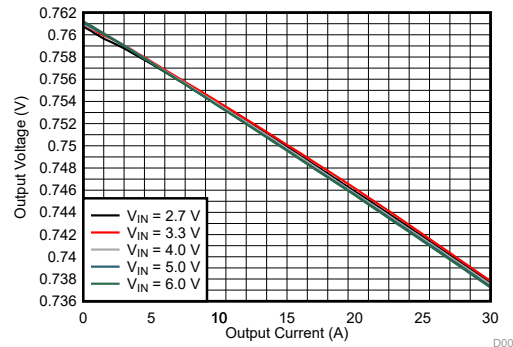

$V_{OUT} = 0.75V$ PWM; TPS62877 droop enabled $T_A = 25^\circ C$

Figure 10-7. Output Voltage vs Output Current

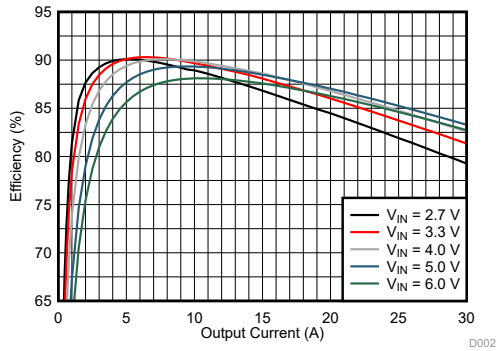

$V_{OUT} = 0.8V$ PWM $T_A = 25^\circ C$

Figure 10-8. Efficiency vs Output Current

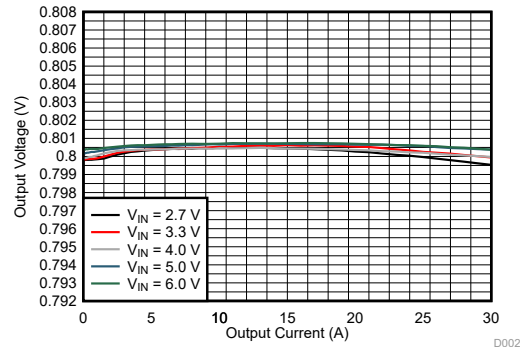

$V_{OUT} = 0.8V$ PWM; droop disabled $T_A = 25^\circ C$

Figure 10-9. Output Voltage vs Output Current

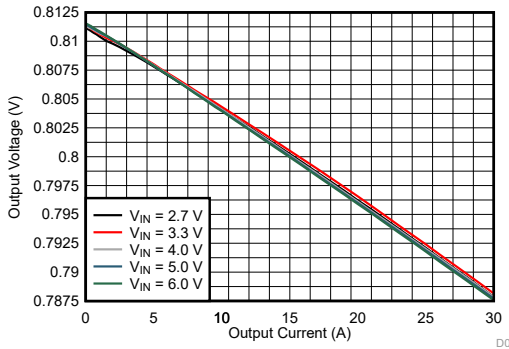

$V_{OUT} = 0.8V$ PWM; TPS62877 droop enabled $T_A = 25^\circ C$

Figure 10-10. Output Voltage vs Output Current

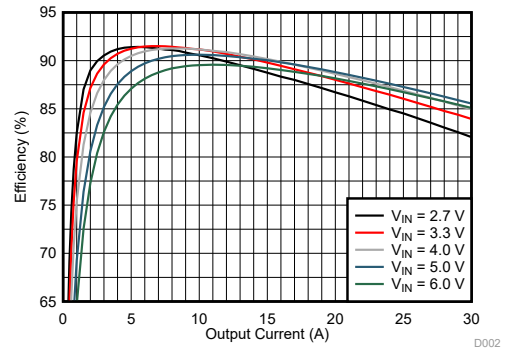

$V_{OUT} = 1.0V$ PWM $T_A = 25^\circ C$

Figure 10-11. Efficiency vs Output Current

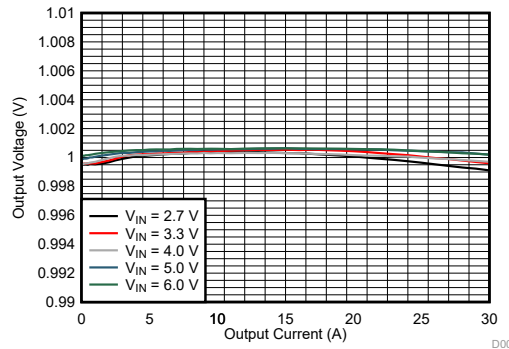

$V_{OUT} = 1.0V$ PWM; droop disabled $T_A = 25^\circ C$

Figure 10-12. Output Voltage vs Output Current

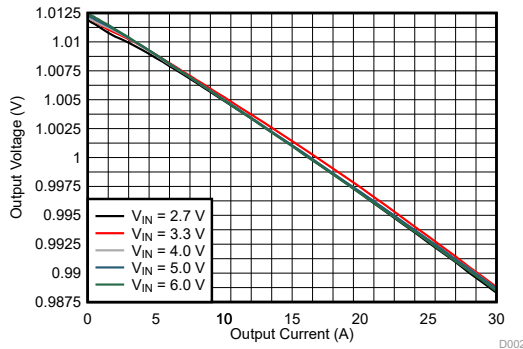

$V_{OUT} = 1.0V$ PWM; TPS62877 droop enabled $T_A = 25^\circ C$

Figure 10-13. Output Voltage vs Output Current

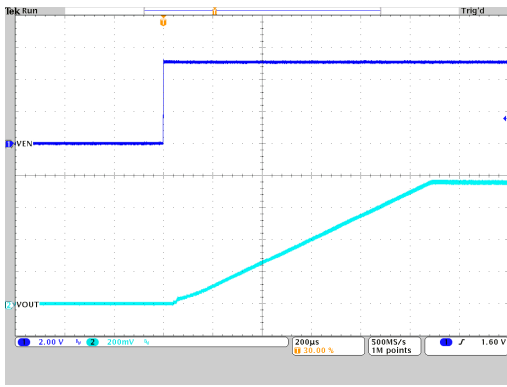

$V_{OUT} = 0.75V$ PWM $T_A = 25^\circ C$
 $V_{IN} = 5V$ $R_{LOAD} = 66m\Omega$

Figure 10-14. Start-Up Timing

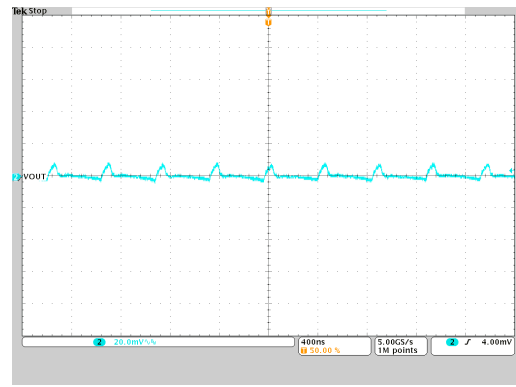

$V_{OUT} = 0.75V$ PWM $T_A = 25^\circ C$
 $V_{IN} = 5V$ $R_{LOAD} = 66m\Omega$

Figure 10-15. Output Voltage Ripple

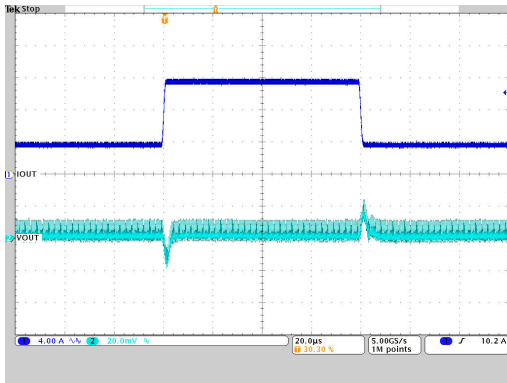

$V_{OUT} = 0.75V$ PWM, TPS62874 $T_A = 25^\circ C$
droop disabled
 $V_{IN} = 5V$ $I_{out} = 3.8A$ to $11.3A$ to $3.8A$

Figure 10-16. Load Transient Response

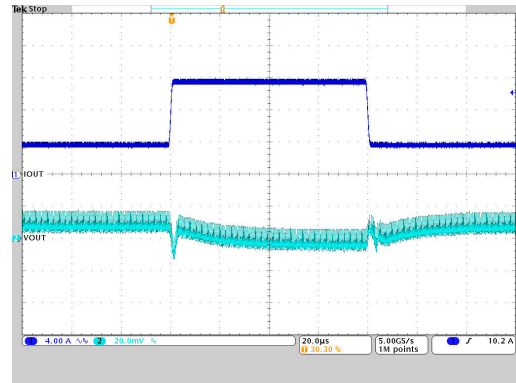

$V_{OUT} = 0.75V$ PWM, TPS62874 $T_A = 25^\circ C$
droop enabled
 $V_{IN} = 5V$ $I_{out} = 3.8A$ to $11.3A$ to $3.8A$

Figure 10-17. Load Transient Response

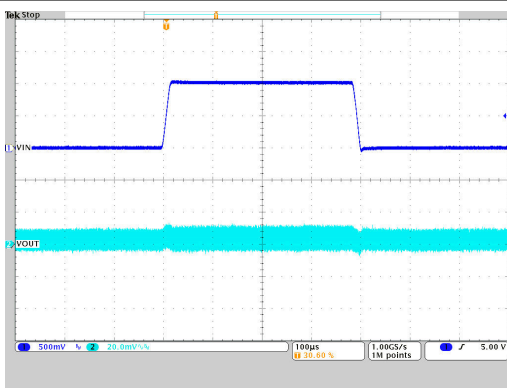

$V_{OUT} = 0.75V$ PWM $T_A = 25^\circ C$
 $V_{IN} = 4.5V$ to $5.5V$ to $4.5V$ $I_{OUT} = 11.3A$

Figure 10-18. Line Transient Response

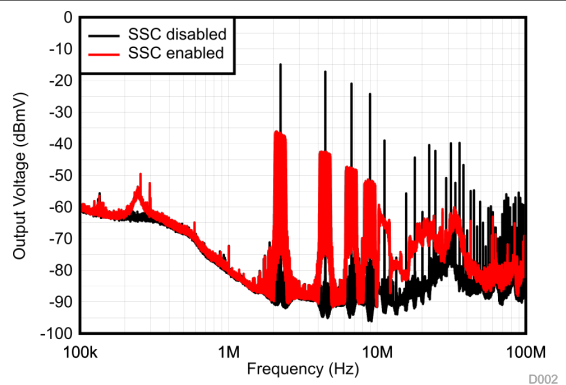

$V_{OUT} = 0.75V$ PWM $T_A = 25^\circ C$
 $V_{IN} = 5V$ $I_{OUT} = 11.3A$

Figure 10-19. Output Voltage Noise

10.3 Typical Application Using Two TPS62876-Q1 in a Stacked Configuration

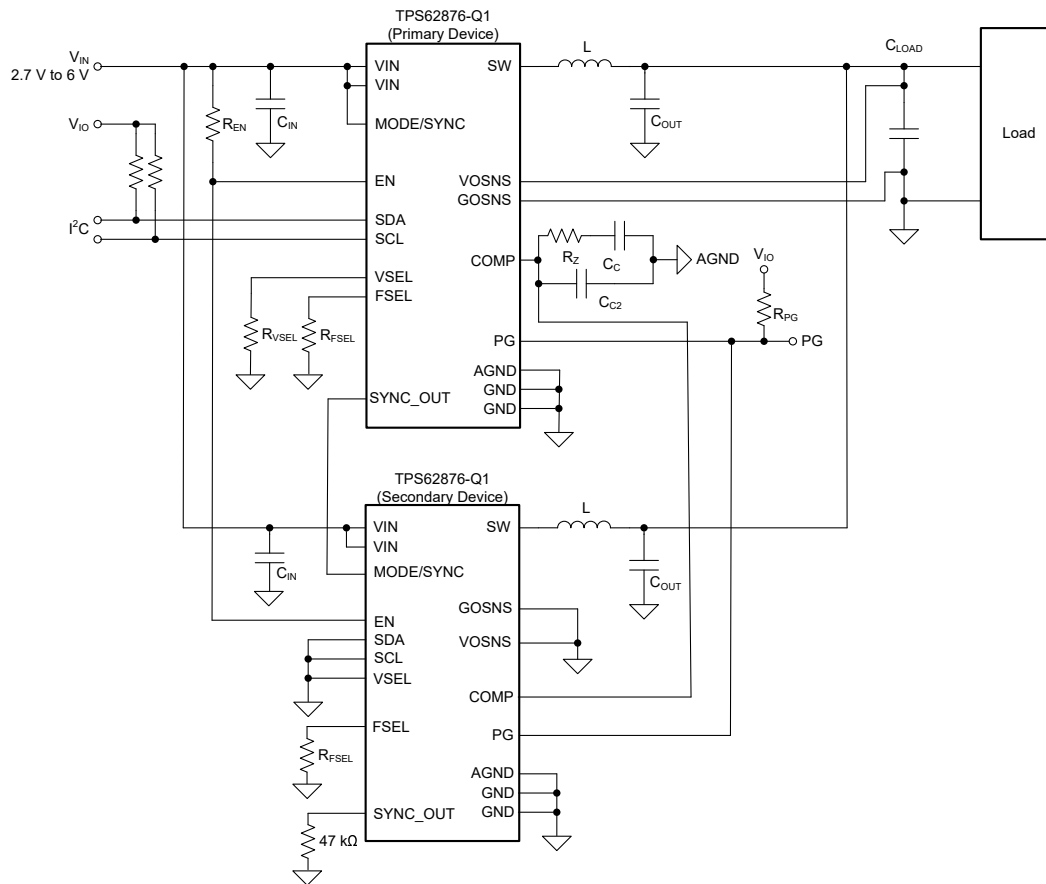

Figure 10-20. Stacking Two Devices

10.3.1 Design Requirements For Two Stacked Devices

Table 10-5 lists the operating parameters for this application example.

Table 10-5. Design Parameters

SYMBOL	PARAMETER	VALUE
V_{IN}	Input voltage	3.3V
V_{OUT}	Output voltage	0.8V
TOL_{VOUT}	Output voltage tolerance allowed by the application	±4%
TOL_{DC}	Output voltage tolerance of the TPS62876-Q1 (DC accuracy)	±0.8%
ΔI_{OUT}	Output current load step	±24A
t_r	Load step rise time	1μs
t_f	Load step fall time	1μs
f_{SW}	Switching frequency	2.25MHz
L	Inductance	56nH
g_m	Error amplifier transconductance	1.5mS
τ	Emulated current time constant	12.5μs
k_{BW}	Ratio of switching frequency to converter bandwidth (must be ≥4)	4

Table 10-5. Design Parameters (continued)

SYMBOL	PARAMETER	VALUE
N_{ϕ}	Number of phases (number of stacked devices)	2
k_{COUT}	Ratio of minimum to maximum output capacitance (typically 2)	2
R_{PG}	Pullup resistor on power-good output	10k Ω
R_{EN}	Pullup resistor on enable	22k Ω
R_{SCL}, R_{SDA}	Pullup resistors on SDA and SCL	680 Ω

Preliminary Calculations

With a total allowable output voltage tolerance of $\pm 4\%$ and a maximum DC error of $\pm 0.8\%$, the allowable output voltage tolerance during a load step is given by:

$$\Delta V_{OUT} = \pm V_{OUT} \times (TOL_{VOUT} - TOL_{DC}) \quad (22)$$

$$\Delta V_{OUT} = \pm 0.8 \times (0.04 - 0.008) = \pm 25.6 \text{ mV} \quad (23)$$

10.3.2 Detailed Design Procedure

10.3.2.1 Selecting the Compensation Resistor

The calculation for a stack of two converters is similar to the single device expect that the parameter "number of phases" N_{ϕ} is added to the equations. Use Equation 24 to calculate the recommended value of compensation resistor R_Z :

$$R_Z = \frac{1}{g_m} \left(\frac{\pi \times \Delta I_{OUT} \times L}{4 \times \tau \times N_{\phi} \times \Delta V_{OUT}} \right) (1 + TOL_{IND}) \quad (24)$$

$$R_Z = \frac{1}{1.5 \times 10^{-3}} \left(\frac{\pi \times 24 \times 56 \times 10^{-9}}{4 \times 12.5 \times 10^{-6} \times 2 \times 25.6 \times 10^{-3}} \right) (1 + 0.2) \Omega = 1.32 \text{ k}\Omega \quad (25)$$

Rounding up, the closest standard value from the E24 series is 1.5 Ω .

10.3.2.2 Selecting the Output Capacitors

If the converter remains in regulation, the minimum output capacitance required is given by:

$$C_{OUT(min)(reg)} = \left(\frac{\tau \times g_m \times R_Z}{2 \times \pi \times \frac{L}{N_{\phi}} \times \frac{f_{SW}}{4}} \right) \left(1 + \sqrt{TOL_{IND}^2 + TOL_{fSW}^2} \right) \quad (26)$$

$$C_{OUT(min)(reg)} = \left(\frac{12.5 \times 10^{-6} \times 1.5 \times 10^{-3} \times 1.5 \times 10^3}{2 \times \pi \times \frac{56 \times 10^{-9}}{2} \times \frac{2.25 \times 10^6}{4}} \right) \left(1 + \sqrt{20\%^2 + 10\%^2} \right) F = 350 \mu F \quad (27)$$

If the converter loop saturates, the minimum output capacitance is given by:

$$C_{OUT(min)(sat)} = \frac{1}{\Delta V_{OUT}} \left(\frac{\frac{L}{N_{\phi}} \times \left(\Delta I_{OUT} + \frac{I_L(PP)}{2} \right)^2}{2 \times V_{OUT}} - \frac{\Delta I_{OUT} \times t_t}{2} \right) (1 + TOL_{IND}) \quad (28)$$

$$C_{OUT(min)(sat)} = \frac{1}{25.6 \times 10^{-3}} \left(\frac{\frac{56 \times 10^{-9}}{2} \times \left(24 + \frac{2.4}{2}\right)^2}{2 \times 0.8} - \frac{24 \times 1 \times 10^{-6}}{2} \right) (1 + 20\%) F = 41.5 \mu F \quad (29)$$

In this case, choose $C_{OUT(min)} = 350 \mu F$, as the larger of the two values, for the output capacitance.

When calculating worst-case component values, use the value calculated above as the *minimum* output capacitance required. For ceramic capacitors, the *nominal* capacitance when considering tolerance, DC bias, temperature, and aging effects is typically two times the minimum capacitance. In this case the nominal capacitance is thus $700 \mu F$.

10.3.2.3 Selecting the Compensation Capacitor C_C

$$BW = \frac{\tau \times g_m \times R_Z}{2 \times \pi \times \frac{L}{N\phi} \times C_{OUT,min} \times k_{COUT}} \quad (30)$$

$$BW = \frac{12.5 \times 10^{-6} \times 1.5 \times 10^{-3} \times 1.5 \times 10^3}{2 \times \pi \times \frac{56 \times 10^{-9}}{2} \times 350 \times 10^{-6} \times 2} = 230 \text{ kHz} \quad (31)$$

Next, calculate C_C :

$$C_C = \frac{k_{BW}}{2 \times \pi \times BW \times R_Z} \quad (32)$$

$$C_C = \frac{4}{2 \times \pi \times 230 \times 10^3 \times 1.5 \times 10^3} = 1.85 \text{ nF} \quad (33)$$

The closest standard value from the E12 series is 2.2 nF .

10.3.3 Application Curves for Two Stacked Devices

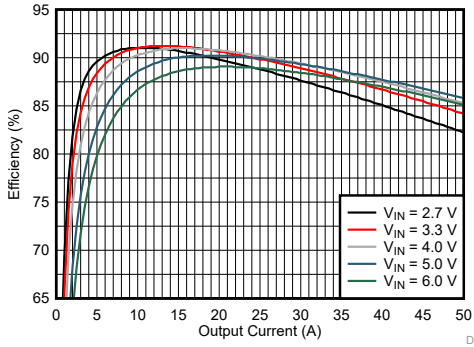

$V_{OUT} = 0.8V$ PWM $T_A = 25^\circ C$

Figure 10-21. Efficiency vs Output Current

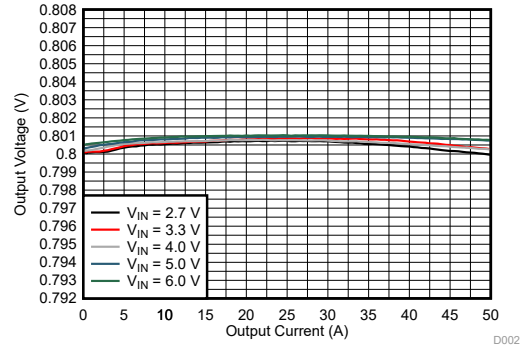

$V_{OUT} = 0.8V$ PWM $T_A = 25^\circ C$

Figure 10-22. Output Voltage vs Output Current

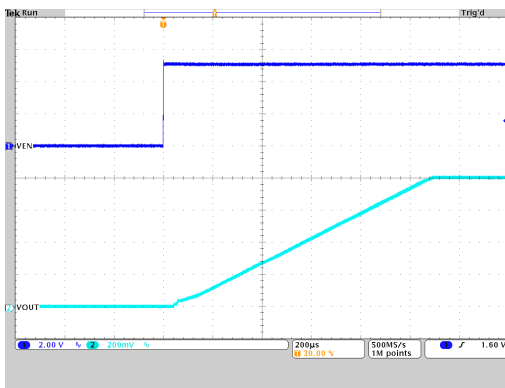

$V_{OUT} = 0.8V$ PWM $T_A = 25^\circ C$
 $V_{IN} = 5V$ $R_{LOAD} = 20m\Omega$

Figure 10-23. Start-Up Timing

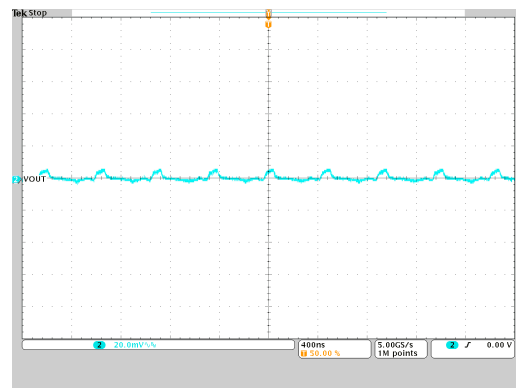

$V_{OUT} = 0.8V$ PWM $T_A = 25^\circ C$
 $V_{IN} = 5V$ $R_{LOAD} = 20m\Omega$

Figure 10-24. Output Voltage Ripple

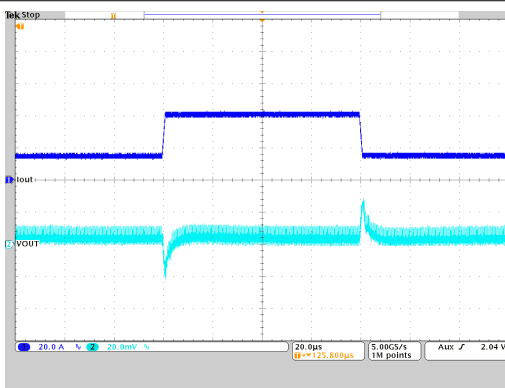

$V_{OUT} = 0.8V$ PWM; TPS62876 $T_A = 25^\circ C$
droop disabled
 $V_{IN} = 5V$ $I_{OUT} = 15A$ to $40A$ to $15A$

Figure 10-25. Load Transient Response

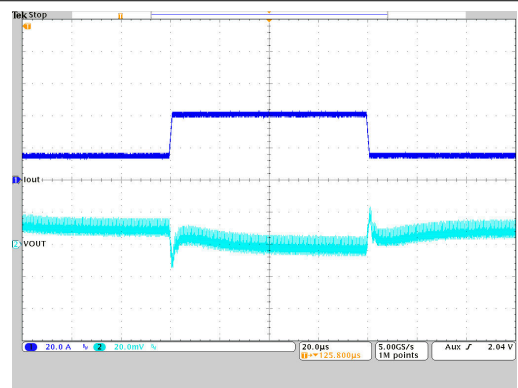

$V_{OUT} = 0.8V$ PWM; TPS62876 $T_A = 25^\circ C$
droop enabled
 $V_{IN} = 5V$ $I_{OUT} = 15A$ to $40A$ to $15A$

Figure 10-26. Load Transient Response

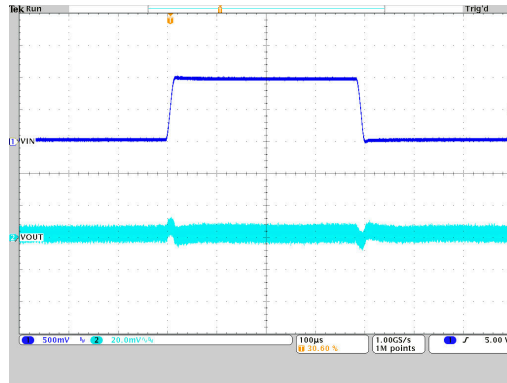

$V_{OUT} = 0.8V$
 $V_{IN} = 4.5V \text{ to } 5.5V \text{ to } 4.5V$

PWM

$T_A = 25^\circ C$
 $I_{OUT} = 40A$

Figure 10-27. Line Transient Response

Table 10-6. Design Parameters (continued)

SYMBOL	PARAMETER	VALUE
ΔI_{OUT}	Output current load step	$\pm 46A$
t_r	Load step rise time	$1\mu s$
t_f	Load step fall time	$1\mu s$
f_{SW}	Switching frequency	2.25MHz
L	Inductance	56nH
g_m	Error amplifier transconductance	1.5mS
τ	Emulated current time constant	12.5 μs
k_{BW}	Ratio of switching frequency to converter bandwidth (must be ≥ 4)	4
N_ϕ	Number of phases (number of stacked devices)	3
k_{COUT}	Ratio of minimum to maximum output capacitance (typically 2)	2
R_{PG}	Pullup resistor on power good output	10k Ω
R_{EN}	Pullup resistor on enable	22k Ω
R_{SCL}, R_{SDA}	Pullup resistors on SDA and SCL	680 Ω

Preliminary Calculations

With a total allowable output voltage tolerance of $\pm 3\%$ and a maximum DC error of $\pm 0.8\%$, the allowable output voltage tolerance during a load step is given by:

$$\Delta V_{OUT} = \pm V_{OUT} \times (TOL_{VOUT} - TOL_{DC}) \quad (34)$$

$$\Delta V_{OUT} = \pm 0.875 \times (0.03 - 0.008) = \pm 19.25 \text{ mV} \quad (35)$$

10.4.2 Detailed Design Procedure

10.4.2.1 Selecting the Compensation Resistor

The calculation for a stack of two converters is similar to the single device expect that the parameter "number of phases" N_ϕ is added to the equations. Use [Equation 36](#) to calculate the recommended value of compensation resistor R_Z :

$$R_Z = \frac{1}{g_m} \left(\frac{\pi \times \Delta I_{OUT} \times L}{4 \times \tau \times N_\phi \times \Delta V_{OUT}} \right) (1 + TOL_{IND}) \quad (36)$$

$$R_Z = \frac{1}{1.5 \times 10^{-3}} \left(\frac{\pi \times 46 \times 56 \times 10^{-9}}{4 \times 12.5 \times 10^{-6} \times 3 \times 19.25 \times 10^{-3}} \right) (1 + 0.2) \Omega = 2.24 \text{ k}\Omega \quad (37)$$

Rounding up, the closest standard value from the E24 series is 2.4k Ω .

10.4.2.2 Selecting the Output Capacitors

If the converter remains in regulation, the minimum output capacitance required is given by:

$$C_{OUT(min)(reg)} = \left(\frac{\tau \times g_m \times R_Z}{2 \times \pi \times \frac{L}{N_\phi} \times \frac{f_{SW}}{4}} \right) \left(1 + \sqrt{TOL_{IND}^2 + TOL_{fSW}^2} \right) \quad (38)$$

$$C_{OUT(min)(reg)} = \left(\frac{12.5 \times 10^{-6} \times 1.5 \times 10^{-3} \times 2.4 \times 10^3}{2 \times \pi \times \frac{56 \times 10^{-9}}{3} \times \frac{2.25 \times 10^6}{4}} \right) \left(1 + \sqrt{20\%^2 + 10\%^2} \right) F = 835 \mu F \quad (39)$$

If the converter loop saturates, the minimum output capacitance is given by:

$$C_{OUT(min)(sat)} = \frac{1}{\Delta V_{OUT}} \left(\frac{\frac{L}{N_{\phi}} \times \left(\Delta I_{OUT} + \frac{I_{L(PP)}}{2} \right)^2}{2 \times V_{OUT}} - \frac{\Delta I_{OUT} \times t_t}{2} \right) (1 + \text{TOL}_{IND}) \quad (40)$$

$$C_{OUT(min)(sat)} = \frac{1}{19.25 \times 10^{-3}} \left(\frac{\frac{56 \times 10^{-9}}{3} \times \left(46 + \frac{2.4}{2} \right)^2}{2 \times 0.875} - \frac{46 \times 1 \times 10^{-6}}{2} \right) (1 + 20\%) F = 25.7 \mu F \quad (41)$$

In this case, choose $C_{OUT(min)} = 835 \mu F$, as the larger of the two values, for the output capacitance.

When calculating worst-case component values, use the value calculated above as the *minimum* output capacitance required. For ceramic capacitors, the *nominal* capacitance when considering tolerance, DC bias, temperature, and aging effects is typically two times the minimum capacitance. In this case the nominal capacitance is thus 1670 μF .

10.4.2.3 Selecting the Compensation Capacitor C_C

$$BW = \frac{\tau \times g_m \times R_Z}{2 \times \pi \times \frac{L}{N_{\phi}} \times C_{OUT,min} \times k_{COUT}} \quad (42)$$

$$BW = \frac{12.5 \times 10^{-6} \times 1.5 \times 10^{-3} \times 2.4 \times 10^3}{2 \times \pi \times \frac{56 \times 10^{-9}}{3} \times 835 \times 10^{-6} \times 2} = 230 \text{ kHz} \quad (43)$$

Next, calculate C_C :

$$C_C = \frac{k_{BW}}{2 \times \pi \times BW \times R_Z} \quad (44)$$

$$C_C = \frac{4}{2 \times \pi \times 230 \times 10^3 \times 2.4 \times 10^3} = 1.15 \text{ nF} \quad (45)$$

The closest standard value from the E12 series is 1.5 nF.

10.4.3 Application Curves for Three Stacked Devices

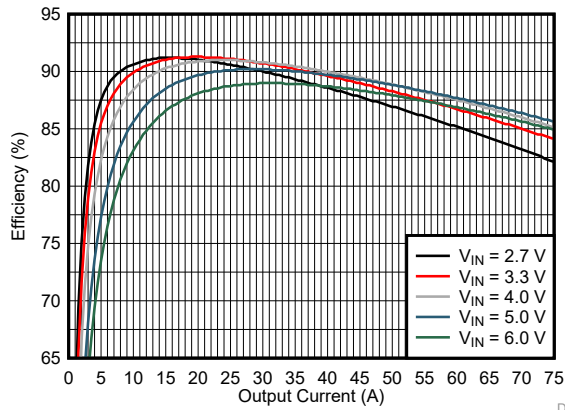

$V_{OUT} = 0.875V$ PWM $T_A = 25^\circ C$

Figure 10-29. Efficiency Versus Output Current

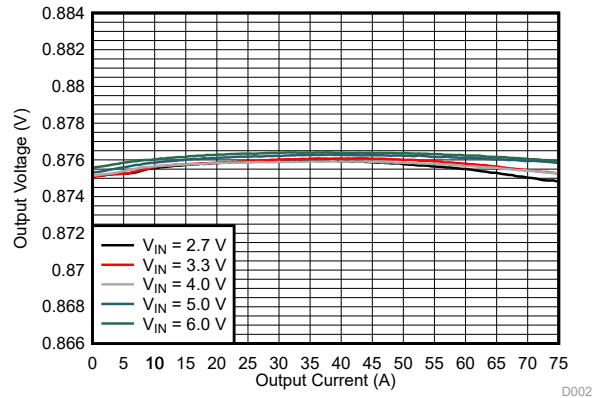

$V_{OUT} = 0.875V$ PWM $T_A = 25^\circ C$

Figure 10-30. Output Voltage Versus Output Current

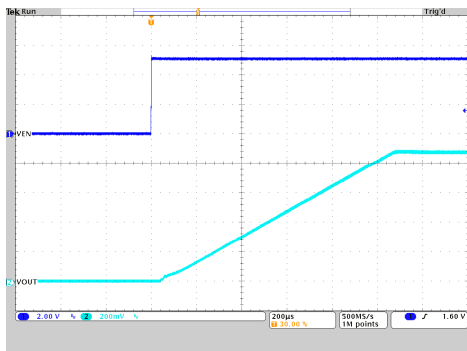

$V_{OUT} = 0.875V$ PWM $T_A = 25^\circ C$
 $V_{IN} = 5V$ $R_{LOAD} = 14m\Omega$

Figure 10-31. Start-Up Timing

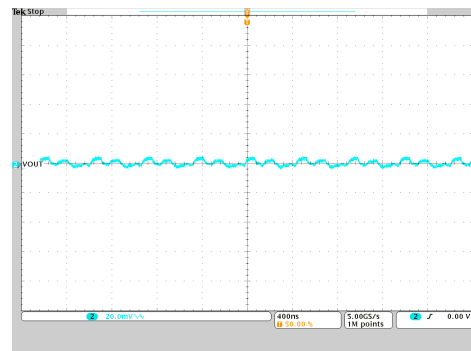

$V_{OUT} = 0.875V$ PWM $T_A = 25^\circ C$
 $V_{IN} = 5V$ $R_{LOAD} = 14m\Omega$

Figure 10-32. Output Voltage Ripple

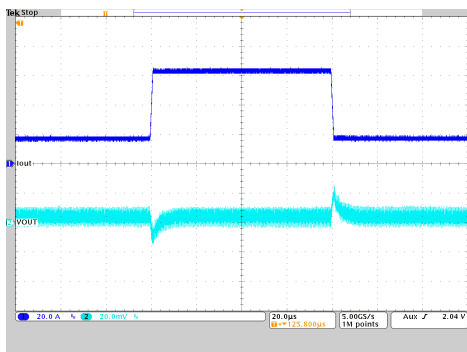

$V_{OUT} = 0.875V$ PWM; TPS62876 $T_A = 25^\circ C$
 droop disabled $I_{out} = 17A$ to $63A$ to $17A$
 $V_{IN} = 5V$

Figure 10-33. Load Transient Response

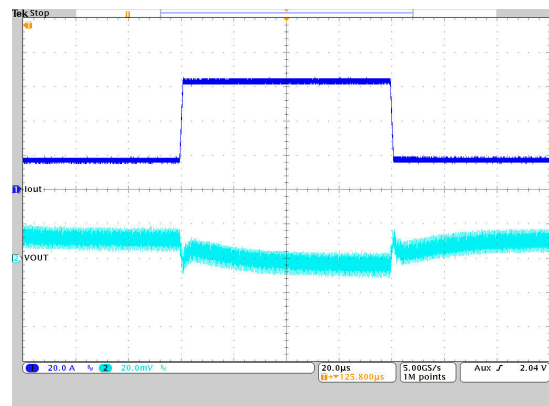

$V_{OUT} = 0.875V$ PWM; TPS62876 $T_A = 25^\circ C$
 droop enabled $I_{out} = 17A$ to $63A$ to $17A$
 $V_{IN} = 5V$

Figure 10-34. Load Transient Response

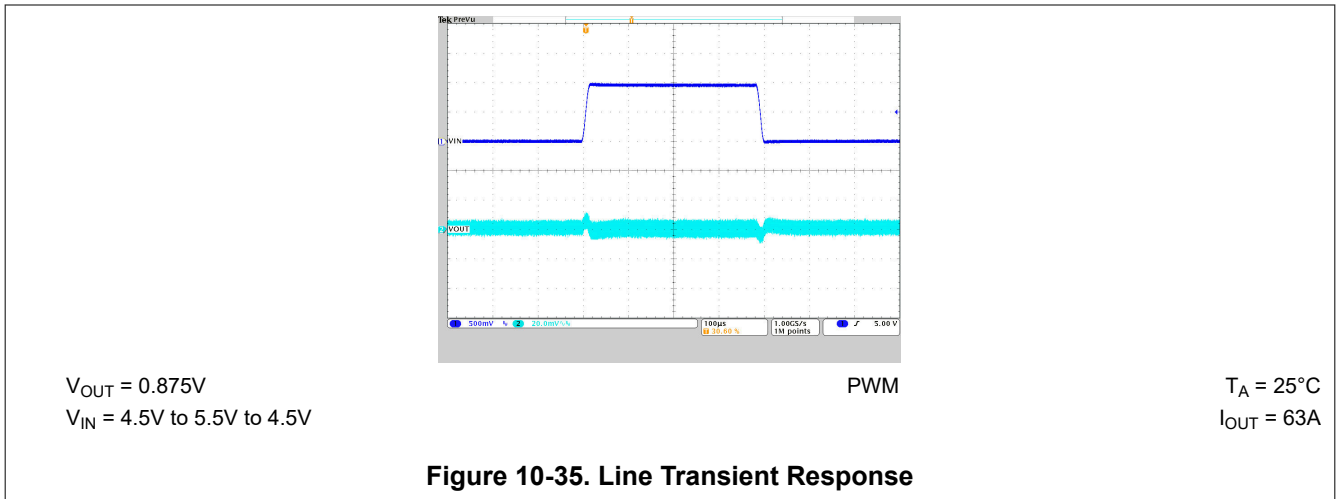

10.5 Best Design Practices

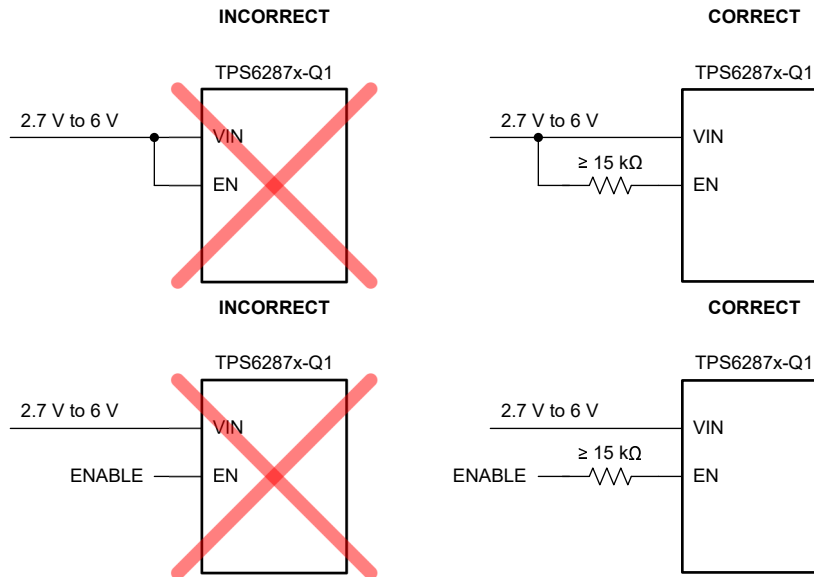

10.6 Power Supply Recommendations

The TPS6287x-Q1 device family has no special requirements for input power supply. The input power supply output current must be rated according to the supply voltage, output voltage, and output current of the TPS6287x-Q1.

10.7 Layout

Achieving the performance the TPS6287x-Q1 devices are capable of requires proper PDN and PCB design. TI therefore recommends the user perform a power integrity analysis on the design. There are a number of commercially available power integrity software tools, and the user can use these tools to model the effects on performance of the PCB layout and passive components.

In addition to the use of power integrity tools, TI recommends the following basic principles:

- Place the input capacitors close to the VIN and GND pins. Position the input capacitors in order of increasing size, starting with the smallest capacitors closest to the VIN and GND pins. Use an identical layout for both VIN-GND pin pairs of the package, to gain maximum benefit from the butterfly configuration.
- Place the inductor close to the device and keep the SW node small.

- Connect the exposed thermal pad and the GND pins of the device together. Use multiple thermal vias to connect the exposed thermal pad of the device to one or more ground planes (TI's EVM uses nine 150µm thermal vias).
- Use multiple power and ground planes.
- Route the VOSNS and GOSNS remote sense lines on the primary device as a differential pair and connect them to the lowest-impedance point of the PDN. If the desired connection point is not the lowest impedance point of the PDN, optimize the PDN until the desired connection point is the lowest impedance point of the PDN. Do not route the VOSNS and GOSNS close to any of the switch nodes.
- Connect the compensation components between COMP and AGND. Do not connect the compensation components directly to power ground.
- If possible, distribute the output capacitors evenly between the TPS6287x-Q1 device and the point-of-load, rather than placing them altogether in one place.
- Use multiple vias to connect each capacitor pad to the power and ground planes (TI's EVM typically uses four vias per pad).
- Use plenty of stitching vias to make sure of a low impedance connection between different power and ground planes.

10.7.1 Layout Guidelines

Figure 10-36 shows the top layer of one of the evaluation modules for this device. The figure demonstrates the practical implementation of the PCB layout principles previously listed. The user can find a complete set drawings of all the layers used in this PCB in the evaluation module user's guide [TPS62876 Buck Converter Evaluation Module](#).

10.7.2 Layout Example

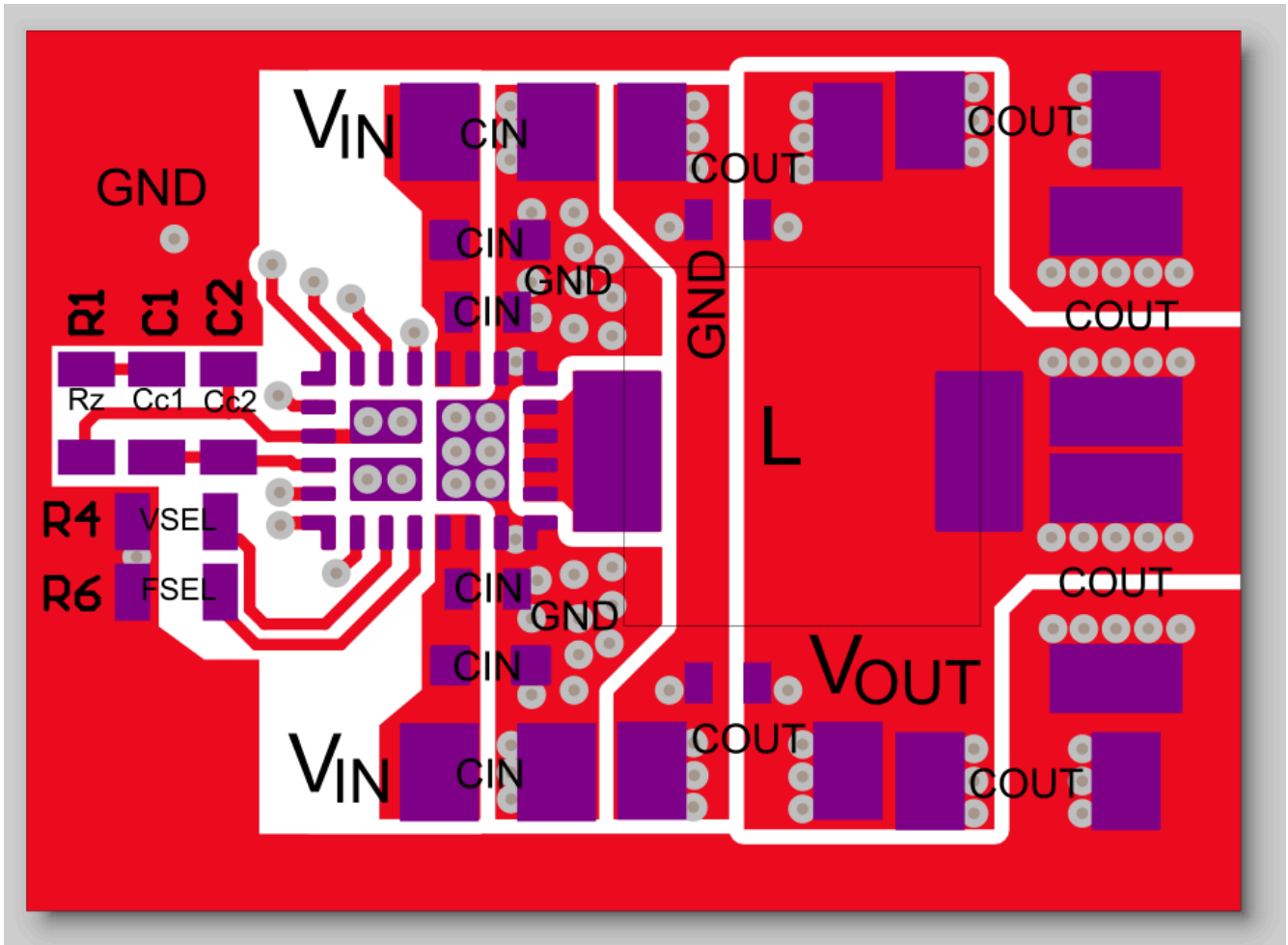

Figure 10-36. TPS62876-Q1 EVM Top Layer

11 Device and Documentation Support

11.1 Documentation Support

11.1.1 Related Documentation

For related documentation, see the following:

Texas Instruments, [TPS62876 Buck Converter Evaluation Module EVM user's guide](#)

11.2 Receiving Notification of Documentation Updates

To receive notification of documentation updates, navigate to the device product folder on ti.com. Click on *Notifications* to register and receive a weekly digest of any product information that has changed. For change details, review the revision history included in any revised document.

11.3 Support Resources

[TI E2E™ support forums](#) are an engineer's go-to source for fast, verified answers and design help — straight from the experts. Search existing answers or ask your own question to get the quick design help you need.

Linked content is provided "AS IS" by the respective contributors. They do not constitute TI specifications and do not necessarily reflect TI's views; see TI's [Terms of Use](#).

11.4 Trademarks

I2C™ is a trademark of NXP Semiconductors.

TI E2E™ is a trademark of Texas Instruments.

All trademarks are the property of their respective owners.

11.5 Electrostatic Discharge Caution



This integrated circuit can be damaged by ESD. Texas Instruments recommends that all integrated circuits be handled with appropriate precautions. Failure to observe proper handling and installation procedures can cause damage.

ESD damage can range from subtle performance degradation to complete device failure. Precision integrated circuits may be more susceptible to damage because very small parametric changes could cause the device not to meet its published specifications.

11.6 Glossary

[TI Glossary](#) This glossary lists and explains terms, acronyms, and definitions.

12 Revision History

NOTE: Page numbers for previous revisions may differ from page numbers in the current version.

Changes from Revision E (August 2025) to Revision F (March 2026)	Page
• Added TPS62875B6QWRZVRQ1 to the <i>Device Options</i> table.....	3
• Updated the format of the <i>Device Options</i> table.....	3
• Added the default register settings in the CONTROL2 register to the <i>Device Options</i> table and deleted the register settings from the CONTROL2 register as the default register settings depend on the orderable part number.....	3
• Deleted comments for non-automotive versions in <i>Start-Up</i>	19
• Deleted "(default)" in Table 8-6 and added this information to the <i>Device Options</i> table.....	22
• Deleted measurement conditions for non-automotive versions in <i>Application Curves</i>	47

Changes from Revision D (December 2024) to Revision E (August 2025)	Page
• Updated the device name.....	44

Changes from Revision C (October 2024) to Revision D (December 2024)	Page
• Deleted preview label on TPS62877B3 in the <i>Device Options</i> table.....	3
• Changed "GND" to "AGND" in <i>Compensation (COMP)</i>	24

13 Mechanical, Packaging, and Orderable Information

The following pages include mechanical, packaging, and orderable information. This information is the most current data available for the designated devices. This data is subject to change without notice and revision of this document. For browser-based versions of this data sheet, refer to the left-hand navigation.

PACKAGING INFORMATION

Orderable part number	Status (1)	Material type (2)	Package Pins	Package qty Carrier	RoHS (3)	Lead finish/ Ball material (4)	MSL rating/ Peak reflow (5)	Op temp (°C)	Part marking (6)
TPS62874B1QWRZVRQ1	Active	Production	WQFN-FCRLF (RZV) 24	3000 LARGE T&R	Yes	NIPDAU	Level-2-260C-1 YEAR	-40 to 125	6874B1Q
TPS62874B1QWRZVRQ1.A	Active	Production	WQFN-FCRLF (RZV) 24	3000 LARGE T&R	Yes	NIPDAU	Level-2-260C-1 YEAR	-40 to 125	6874B1Q
TPS62874B4QWRZVRQ1	Active	Production	WQFN-FCRLF (RZV) 24	3000 LARGE T&R	Yes	NIPDAU	Level-2-260C-1 YEAR	-40 to 125	6874B4Q
TPS62874B4QWRZVRQ1.A	Active	Production	WQFN-FCRLF (RZV) 24	3000 LARGE T&R	Yes	NIPDAU	Level-2-260C-1 YEAR	-40 to 125	6874B4Q
TPS62874QWRZVRQ1	Active	Production	WQFN-FCRLF (RZV) 24	3000 LARGE T&R	Yes	NIPDAU	Level-2-260C-1 YEAR	-40 to 125	62874Q
TPS62874QWRZVRQ1.A	Active	Production	WQFN-FCRLF (RZV) 24	3000 LARGE T&R	Yes	NIPDAU	Level-2-260C-1 YEAR	-40 to 125	62874Q
TPS62875B1QWRZVRQ1	Active	Production	WQFN-FCRLF (RZV) 24	3000 LARGE T&R	Yes	NIPDAU	Level-2-260C-1 YEAR	-40 to 125	6875B1Q
TPS62875B1QWRZVRQ1.A	Active	Production	WQFN-FCRLF (RZV) 24	3000 LARGE T&R	Yes	NIPDAU	Level-2-260C-1 YEAR	-40 to 125	6875B1Q
TPS62875B2QWRZVRQ1	Active	Production	WQFN-FCRLF (RZV) 24	3000 LARGE T&R	Yes	NIPDAU	Level-2-260C-1 YEAR	-40 to 125	6875B2Q
TPS62875B2QWRZVRQ1.A	Active	Production	WQFN-FCRLF (RZV) 24	3000 LARGE T&R	Yes	NIPDAU	Level-2-260C-1 YEAR	-40 to 125	6875B2Q
TPS62875B3QWRZVRQ1	Active	Production	WQFN-FCRLF (RZV) 24	3000 LARGE T&R	Yes	NIPDAU	Level-2-260C-1 YEAR	-40 to 125	6875B3Q
TPS62875B3QWRZVRQ1.A	Active	Production	WQFN-FCRLF (RZV) 24	3000 LARGE T&R	Yes	NIPDAU	Level-2-260C-1 YEAR	-40 to 125	6875B3Q
TPS62875B4QWRZVRQ1	Active	Production	WQFN-FCRLF (RZV) 24	3000 LARGE T&R	Yes	NIPDAU	Level-2-260C-1 YEAR	-40 to 125	6875B4Q
TPS62875B4QWRZVRQ1.A	Active	Production	WQFN-FCRLF (RZV) 24	3000 LARGE T&R	Yes	NIPDAU	Level-2-260C-1 YEAR	-40 to 125	6875B4Q
TPS62875B5QWRZVRQ1	Active	Production	WQFN-FCRLF (RZV) 24	3000 LARGE T&R	Yes	NIPDAU	Level-2-260C-1 YEAR	-40 to 125	6875B5Q
TPS62875B5QWRZVRQ1.A	Active	Production	WQFN-FCRLF (RZV) 24	3000 LARGE T&R	Yes	NIPDAU	Level-2-260C-1 YEAR	-40 to 125	6875B5Q

Orderable part number	Status (1)	Material type (2)	Package Pins	Package qty Carrier	RoHS (3)	Lead finish/ Ball material (4)	MSL rating/ Peak reflow (5)	Op temp (°C)	Part marking (6)
TPS62875B6QWRZVRQ1	Active	Production	WQFN-FCRLF (RZV) 24	3000 LARGE T&R	Yes	NIPDAU	Level-2-260C-1 YEAR	-40 to 125	6875B6Q
TPS62875QWRZVRQ1	Active	Production	WQFN-FCRLF (RZV) 24	3000 LARGE T&R	Yes	NIPDAU	Level-2-260C-1 YEAR	-40 to 125	62875Q
TPS62875QWRZVRQ1.A	Active	Production	WQFN-FCRLF (RZV) 24	3000 LARGE T&R	Yes	NIPDAU	Level-2-260C-1 YEAR	-40 to 125	62875Q
TPS62876B1QWRZVRQ1	Active	Production	WQFN-FCRLF (RZV) 24	3000 LARGE T&R	Yes	NIPDAU	Level-2-260C-1 YEAR	-40 to 125	6876B1Q
TPS62876B1QWRZVRQ1.A	Active	Production	WQFN-FCRLF (RZV) 24	3000 LARGE T&R	Yes	NIPDAU	Level-2-260C-1 YEAR	-40 to 125	6876B1Q
TPS62876B3QWRZVRQ1	Active	Production	WQFN-FCRLF (RZV) 24	3000 LARGE T&R	Yes	NIPDAU	Level-2-260C-1 YEAR	-40 to 125	6876B3Q
TPS62876B3QWRZVRQ1.A	Active	Production	WQFN-FCRLF (RZV) 24	3000 LARGE T&R	Yes	NIPDAU	Level-2-260C-1 YEAR	-40 to 125	6876B3Q
TPS62876QWRZVRQ1	Active	Production	WQFN-FCRLF (RZV) 24	3000 LARGE T&R	Yes	NIPDAU	Level-2-260C-1 YEAR	-40 to 125	62876Q
TPS62876QWRZVRQ1.A	Active	Production	WQFN-FCRLF (RZV) 24	3000 LARGE T&R	Yes	NIPDAU	Level-2-260C-1 YEAR	-40 to 125	62876Q
TPS62877B1QWRZVRQ1	Active	Production	WQFN-FCRLF (RZV) 24	3000 LARGE T&R	Yes	NIPDAU	Level-2-260C-1 YEAR	-40 to 125	6877B1Q
TPS62877B1QWRZVRQ1.A	Active	Production	WQFN-FCRLF (RZV) 24	3000 LARGE T&R	Yes	NIPDAU	Level-2-260C-1 YEAR	-40 to 125	6877B1Q
TPS62877B3QWRZVRQ1	Active	Production	WQFN-FCRLF (RZV) 24	3000 LARGE T&R	Yes	NIPDAU	Level-2-260C-1 YEAR	-40 to 125	6877B3Q
TPS62877B3QWRZVRQ1.A	Active	Production	WQFN-FCRLF (RZV) 24	3000 LARGE T&R	Yes	NIPDAU	Level-2-260C-1 YEAR	-40 to 125	6877B3Q
TPS62877QWRZVRQ1	Active	Production	WQFN-FCRLF (RZV) 24	3000 LARGE T&R	Yes	NIPDAU	Level-2-260C-1 YEAR	-40 to 125	62877Q
TPS62877QWRZVRQ1.A	Active	Production	WQFN-FCRLF (RZV) 24	3000 LARGE T&R	Yes	NIPDAU	Level-2-260C-1 YEAR	-40 to 125	62877Q

(1) **Status:** For more details on status, see our [product life cycle](#).

(2) **Material type:** When designated, preproduction parts are prototypes/experimental devices, and are not yet approved or released for full production. Testing and final process, including without limitation quality assurance, reliability performance testing, and/or process qualification, may not yet be complete, and this item is subject to further changes or possible discontinuation. If available for ordering, purchases will be subject to an additional waiver at checkout, and are intended for early internal evaluation purposes only. These items are sold without warranties of any kind.

(3) **RoHS values:** Yes, No, RoHS Exempt. See the [TI RoHS Statement](#) for additional information and value definition.

(4) **Lead finish/Ball material:** Parts may have multiple material finish options. Finish options are separated by a vertical ruled line. Lead finish/Ball material values may wrap to two lines if the finish value exceeds the maximum column width.

(5) **MSL rating/Peak reflow:** The moisture sensitivity level ratings and peak solder (reflow) temperatures. In the event that a part has multiple moisture sensitivity ratings, only the lowest level per JEDEC standards is shown. Refer to the shipping label for the actual reflow temperature that will be used to mount the part to the printed circuit board.

(6) **Part marking:** There may be an additional marking, which relates to the logo, the lot trace code information, or the environmental category of the part.

Multiple part markings will be inside parentheses. Only one part marking contained in parentheses and separated by a "~" will appear on a part. If a line is indented then it is a continuation of the previous line and the two combined represent the entire part marking for that device.

Important Information and Disclaimer:The information provided on this page represents TI's knowledge and belief as of the date that it is provided. TI bases its knowledge and belief on information provided by third parties, and makes no representation or warranty as to the accuracy of such information. Efforts are underway to better integrate information from third parties. TI has taken and continues to take reasonable steps to provide representative and accurate information but may not have conducted destructive testing or chemical analysis on incoming materials and chemicals. TI and TI suppliers consider certain information to be proprietary, and thus CAS numbers and other limited information may not be available for release.

In no event shall TI's liability arising out of such information exceed the total purchase price of the TI part(s) at issue in this document sold by TI to Customer on an annual basis.

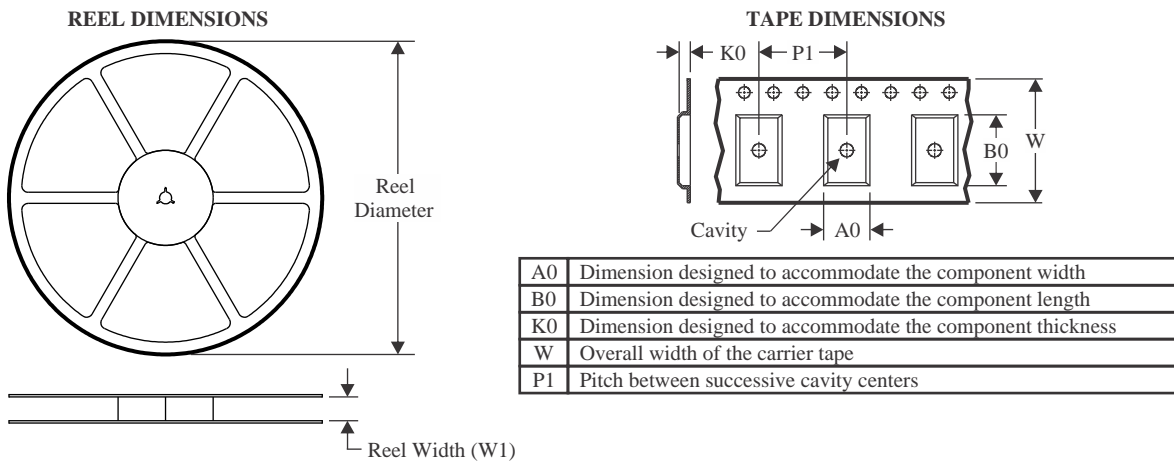
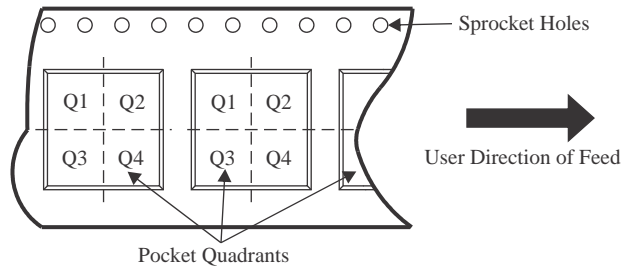
TAPE AND REEL INFORMATION

QUADRANT ASSIGNMENTS FOR PIN 1 ORIENTATION IN TAPE

*All dimensions are nominal

Device	Package Type	Package Drawing	Pins	SPQ	Reel Diameter (mm)	Reel Width W1 (mm)	A0 (mm)	B0 (mm)	K0 (mm)	P1 (mm)	W (mm)	Pin1 Quadrant
TPS62874B1QWRZVRQ1	WQFN-FCRLF	RZV	24	3000	330.0	12.4	3.3	4.4	0.8	8.0	12.0	Q1
TPS62874B4QWRZVRQ1	WQFN-FCRLF	RZV	24	3000	330.0	12.4	3.3	4.4	0.8	8.0	12.0	Q1
TPS62874QWRZVRQ1	WQFN-FCRLF	RZV	24	3000	330.0	12.4	3.3	4.4	0.8	8.0	12.0	Q1
TPS62875B1QWRZVRQ1	WQFN-FCRLF	RZV	24	3000	330.0	12.4	3.3	4.4	0.8	8.0	12.0	Q1
TPS62875B2QWRZVRQ1	WQFN-FCRLF	RZV	24	3000	330.0	12.4	3.3	4.4	0.8	8.0	12.0	Q1
TPS62875B3QWRZVRQ1	WQFN-FCRLF	RZV	24	3000	330.0	12.4	3.3	4.4	0.8	8.0	12.0	Q1
TPS62875B4QWRZVRQ1	WQFN-FCRLF	RZV	24	3000	330.0	12.4	3.3	4.4	0.8	8.0	12.0	Q1
TPS62875B5QWRZVRQ1	WQFN-FCRLF	RZV	24	3000	330.0	12.4	3.3	4.4	0.8	8.0	12.0	Q1
TPS62875B6QWRZVRQ1	WQFN-FCRLF	RZV	24	3000	330.0	12.4	3.3	4.4	0.8	8.0	12.0	Q1

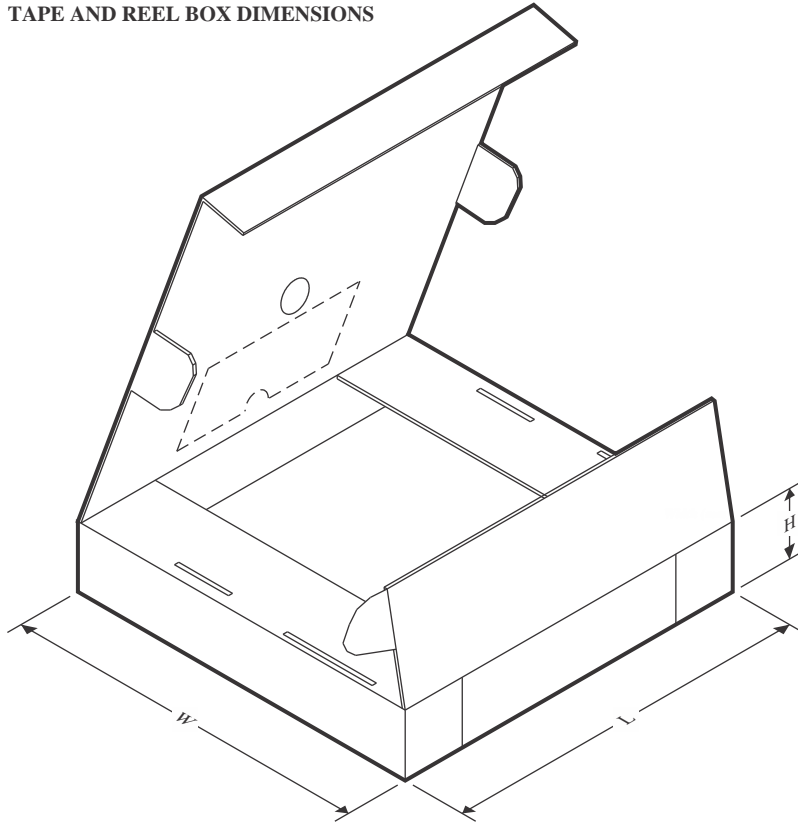
Device	Package Type	Package Drawing	Pins	SPQ	Reel Diameter (mm)	Reel Width W1 (mm)	A0 (mm)	B0 (mm)	K0 (mm)	P1 (mm)	W (mm)	Pin1 Quadrant
TPS62875QWRZVRQ1	WQFN-FCRLF	RZV	24	3000	330.0	12.4	3.3	4.4	0.8	8.0	12.0	Q1
TPS62876B1QWRZVRQ1	WQFN-FCRLF	RZV	24	3000	330.0	12.4	3.3	4.4	0.8	8.0	12.0	Q1
TPS62876B3QWRZVRQ1	WQFN-FCRLF	RZV	24	3000	330.0	12.4	3.3	4.4	0.8	8.0	12.0	Q1
TPS62876QWRZVRQ1	WQFN-FCRLF	RZV	24	3000	330.0	12.4	3.3	4.4	0.8	8.0	12.0	Q1
TPS62877B1QWRZVRQ1	WQFN-FCRLF	RZV	24	3000	330.0	12.4	3.3	4.4	0.8	8.0	12.0	Q1
TPS62877B3QWRZVRQ1	WQFN-FCRLF	RZV	24	3000	330.0	12.4	3.3	4.4	0.8	8.0	12.0	Q1
TPS62877QWRZVRQ1	WQFN-FCRLF	RZV	24	3000	330.0	12.4	3.3	4.4	0.8	8.0	12.0	Q1

TAPE AND REEL BOX DIMENSIONS

*All dimensions are nominal

Device	Package Type	Package Drawing	Pins	SPQ	Length (mm)	Width (mm)	Height (mm)
TPS62874B1QWRZVRQ1	WQFN-FCRLF	RZV	24	3000	338.0	355.0	35.0
TPS62874B4QWRZVRQ1	WQFN-FCRLF	RZV	24	3000	338.0	355.0	35.0
TPS62874QWRZVRQ1	WQFN-FCRLF	RZV	24	3000	338.0	355.0	35.0
TPS62875B1QWRZVRQ1	WQFN-FCRLF	RZV	24	3000	338.0	355.0	35.0
TPS62875B2QWRZVRQ1	WQFN-FCRLF	RZV	24	3000	338.0	355.0	35.0
TPS62875B3QWRZVRQ1	WQFN-FCRLF	RZV	24	3000	338.0	355.0	35.0
TPS62875B4QWRZVRQ1	WQFN-FCRLF	RZV	24	3000	338.0	355.0	35.0
TPS62875B5QWRZVRQ1	WQFN-FCRLF	RZV	24	3000	338.0	355.0	35.0
TPS62875B6QWRZVRQ1	WQFN-FCRLF	RZV	24	3000	338.0	355.0	35.0
TPS62875QWRZVRQ1	WQFN-FCRLF	RZV	24	3000	338.0	355.0	35.0
TPS62876B1QWRZVRQ1	WQFN-FCRLF	RZV	24	3000	338.0	355.0	35.0
TPS62876B3QWRZVRQ1	WQFN-FCRLF	RZV	24	3000	338.0	355.0	35.0
TPS62876QWRZVRQ1	WQFN-FCRLF	RZV	24	3000	338.0	355.0	35.0
TPS62877B1QWRZVRQ1	WQFN-FCRLF	RZV	24	3000	338.0	355.0	35.0
TPS62877B3QWRZVRQ1	WQFN-FCRLF	RZV	24	3000	338.0	355.0	35.0
TPS62877QWRZVRQ1	WQFN-FCRLF	RZV	24	3000	338.0	355.0	35.0

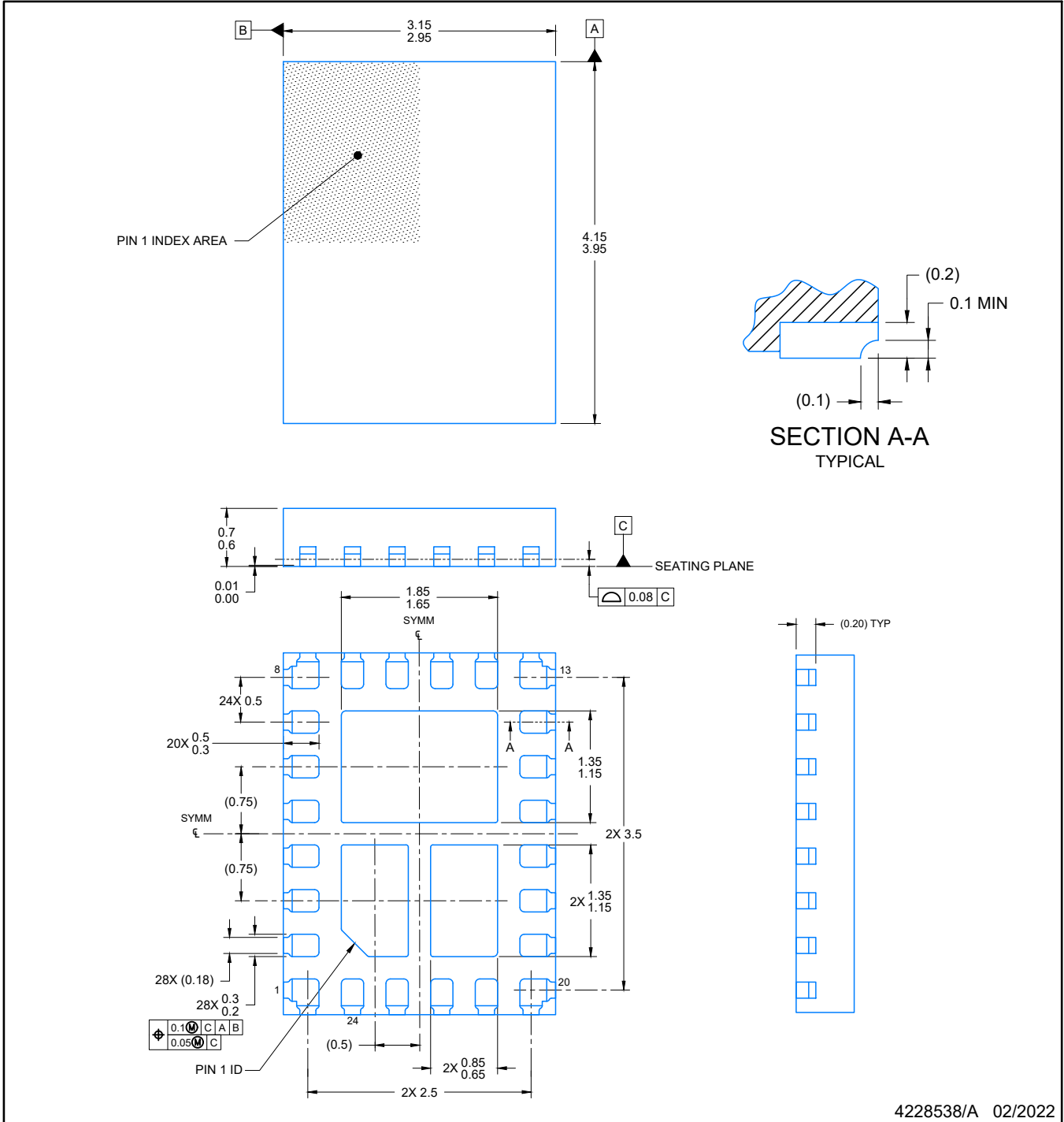

NOTES:

1. All linear dimensions are in millimeters. Any dimensions in parenthesis are for reference only. Dimensioning and tolerancing per ASME Y14.5M.
2. This drawing is subject to change without notice.
3. The package thermal pad must be soldered to the printed circuit board for optimal thermal and mechanical performance.

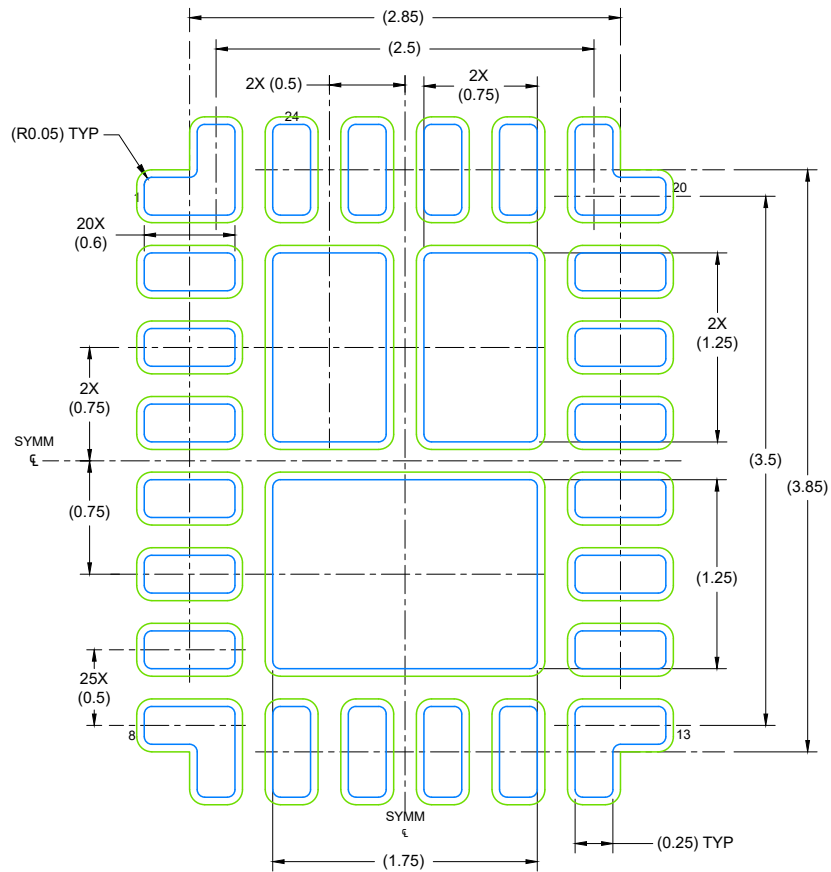

LAND PATTERN EXAMPLE
 EXPOSED METAL SHOWN
 SCALE: 20X

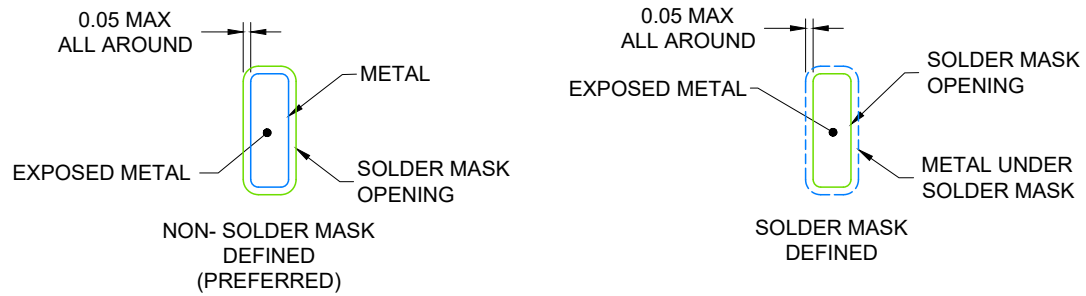

SOLDER MASK DETAILS

4228538/A 02/2022

NOTES: (continued)

4. This package is designed to be soldered to a thermal pad on the board. For more information, see Texas Instruments literature number SLUA271 (www.ti.com/lit/sluea271).
5. Vias are optional depending on application, refer to device data sheet. If any vias are implemented, refer to their locations shown on this view. It is recommended that vias under paste be filled, plugged or tented.

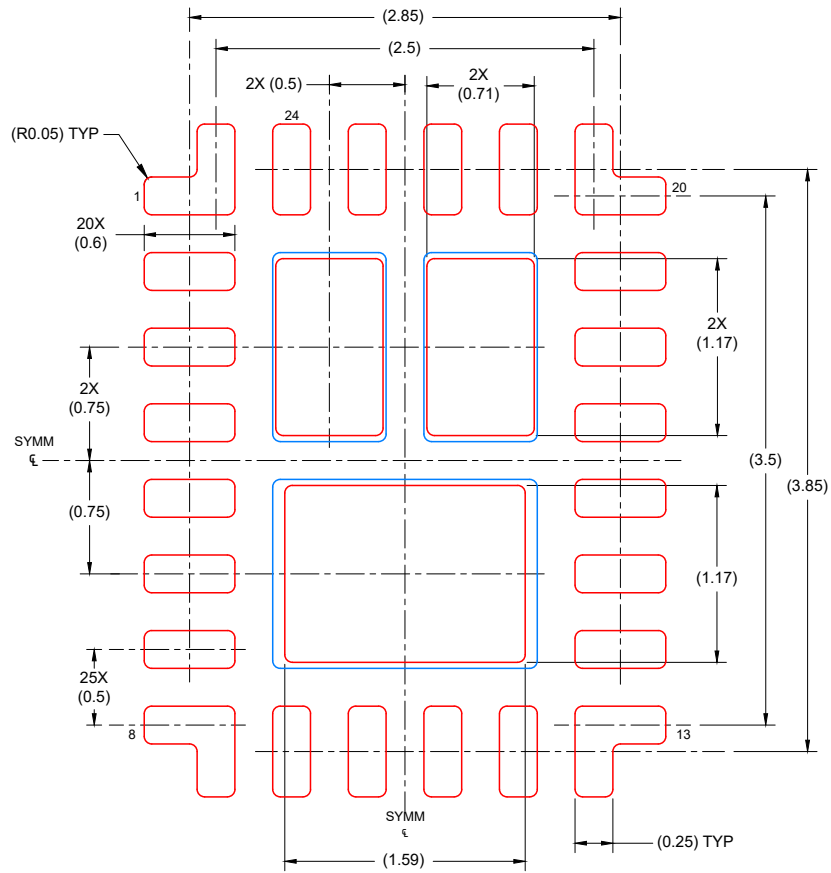

SOLDER PASTE EXAMPLE
BASED ON 0.1 mm THICK STENCIL

SCALE: 15X

NOTES: (continued)

- 6. Laser cutting apertures with trapezoidal walls and rounded corners may offer better paste release. IPC-7525 may have alternate design recommendations.

IMPORTANT NOTICE AND DISCLAIMER

TI PROVIDES TECHNICAL AND RELIABILITY DATA (INCLUDING DATASHEETS), DESIGN RESOURCES (INCLUDING REFERENCE DESIGNS), APPLICATION OR OTHER DESIGN ADVICE, WEB TOOLS, SAFETY INFORMATION, AND OTHER RESOURCES "AS IS" AND WITH ALL FAULTS, AND DISCLAIMS ALL WARRANTIES, EXPRESS AND IMPLIED, INCLUDING WITHOUT LIMITATION ANY IMPLIED WARRANTIES OF MERCHANTABILITY, FITNESS FOR A PARTICULAR PURPOSE OR NON-INFRINGEMENT OF THIRD PARTY INTELLECTUAL PROPERTY RIGHTS.

These resources are intended for skilled developers designing with TI products. You are solely responsible for (1) selecting the appropriate TI products for your application, (2) designing, validating and testing your application, and (3) ensuring your application meets applicable standards, and any other safety, security, regulatory or other requirements.

These resources are subject to change without notice. TI grants you permission to use these resources only for development of an application that uses the TI products described in the resource. Other reproduction and display of these resources is prohibited. No license is granted to any other TI intellectual property right or to any third party intellectual property right. TI disclaims responsibility for, and you fully indemnify TI and its representatives against any claims, damages, costs, losses, and liabilities arising out of your use of these resources.

TI's products are provided subject to [TI's Terms of Sale](#), [TI's General Quality Guidelines](#), or other applicable terms available either on ti.com or provided in conjunction with such TI products. TI's provision of these resources does not expand or otherwise alter TI's applicable warranties or warranty disclaimers for TI products. Unless TI explicitly designates a product as custom or customer-specified, TI products are standard, catalog, general purpose devices.

TI objects to and rejects any additional or different terms you may propose.

Copyright © 2026, Texas Instruments Incorporated

Last updated 10/2025

Looking for pricing, stock, or lifecycle information?

Click below to explore more details on WIN SOURCE:

 [View TPA8304-TS2R-S on WIN SOURCE](#)

 [3Peak Information](#)

Optimize Your Supply Chain with WIN SOURCE Solutions

-  Global Sourcing Solution
-  Obsolete Management
-  Cost Control Management
-  Shortage Management
-  Alternative Solution
-  Excess Inventory Management