



**THE DATASHEET OF  
TPS629206QDRLRQ1**



# TPSI2140-Q1 1200-V, 50-mA, Automotive Isolated Switch With 2-mA Avalanche Rating

## 1 Features

- Qualified for automotive applications
  - AEC-Q100 grade 1:  $-40$  to  $125^{\circ}\text{C}$   $T_A$
- Integrated avalanche rated MOSFETs
  - Designed and qualified for reliability during overvoltage conditions, including system level dielectric withstand testing (Hi-Pot)
    - $I_{AVA} = 2\text{-mA}$  for 5-s pulses, 1-mA for 60-s pulses
  - 1200-V standoff voltage
  - $R_{ON} = 130\text{-}\Omega$  ( $T_J = 25^{\circ}\text{C}$ )
  - $T_{ON}, T_{OFF} < 700\text{-}\mu\text{s}$
- Low primary side supply current
  - 9-mA ON state current
  - 3.5- $\mu\text{A}$  OFF state current
- Functional Safety Capable
  - Documentation available to aid in ISO 26262 and IEC 61508 system design
- Robust isolation barrier:
  - $> 26$  year projected lifetime at 1000- $V_{RMS}$  / 1500- $V_{DC}$  working voltage
  - Isolation rating,  $V_{ISO}$ , up to 3750- $V_{RMS}$  / 5300- $V_{DC}$
  - Peak surge,  $V_{IOSM}$ , up to 5000-V
  - $\pm 100\text{-V/ns}$  typical CMTI
- SOIC 11-pin (DWQ) package with wide pins for improved thermal performance
  - Creepage and clearance  $\geq 8\text{-mm}$  (primary-secondary)
  - Creepage and clearance  $\geq 6\text{-mm}$  (across switch terminals)
- Safety-related certifications
  - (Planned) DIN VDE V 0884-11:2017-01
  - (Planned) UL 1577 component recognition program

## 2 Applications

- Solid state relay
- Hybrid, electric, and power train systems
- Battery Management Systems (BMS)
- Energy Storage Systems (ESS)
- Solar energy
- Onboard charger
- EV charging infrastructure
- See also the [TI Reference Designs](#) related to these applications.

## 3 Description

The TPSI2140-Q1 is an isolated solid state relay designed for high voltage automotive and

industrial applications. The TPSI2140-Q1 uses TI's high reliability capacitive isolation technology in combination with internal back-to-back MOSFETs to form a completely integrated solution requiring no secondary side power supply.

The primary side of the device is powered by only 9 mA of input current and incorporates a fail-safe EN pin preventing any possibility of back powering the VDD supply. In most applications, the VDD pin of the device should be connected to a system supply between 5 V–20 V and the EN pin of the device should be driven by a GPIO output with logic HI between 2.1 V–20 V. In other applications, The VDD and EN pins could be driven together directly from the system supply or from a GPIO output. All control configurations of the TPSI2140-Q1 do not require additional external components such as a resistor and/or low side switch that are typically required in photo relay solutions.

The secondary side consists of back-to-back MOSFETs with a standoff voltage of  $\pm 1.2$  kV from S1 to S2. The TPSI2140-Q1 MOSFET's avalanche robustness and thermally conscious package design allow it to robustly support system level dielectric withstand testing (HiPot) and DC fast charger surge currents of up to 2 mA without requiring any external components.

### Package Information

PART NUMBER	PACKAGE <sup>(1)</sup>	BODY SIZE (NOM)
TPSI2140-Q1	SOIC 11-pin (DWQ)	10.3 mm × 7.5 mm

- (1) For all available packages, see the orderable addendum at the end of the data sheet.

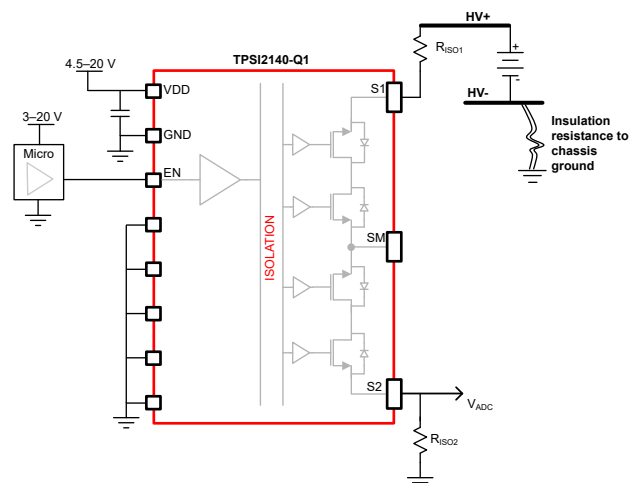

**TPSI2140-Q1 Simplified Application Schematic**



## Table of Contents

<b>1 Features</b> .....	1	<b>8 Detailed Description</b> .....	12
<b>2 Applications</b> .....	1	8.1 Overview.....	12
<b>3 Description</b> .....	1	8.2 Functional Block Diagram.....	12
<b>4 Revision History</b> .....	2	8.3 Feature Description.....	13
<b>5 Pin Configuration and Functions</b> .....	3	8.4 Device Functional Modes.....	14
5.1 Pin Functions.....	3	<b>9 Application and Implementation</b> .....	15
<b>6 Specifications</b> .....	4	9.1 Application Information.....	15
6.1 Absolute Maximum Ratings.....	4	9.2 Typical Application.....	15
6.2 ESD Ratings.....	4	9.3 Power Supply Recommendations.....	22
6.3 Recommended Operating Conditions.....	5	9.4 Layout.....	22
6.4 Thermal Information.....	5	<b>10 Device and Documentation Support</b> .....	31
6.5 Power Ratings.....	5	10.1 Receiving Notification of Documentation Updates.....	31
6.6 Insulation Specifications.....	6	10.2 Support Resources.....	31
6.7 Safety-Related Certifications.....	7	10.3 Trademarks.....	31
6.8 Safety Limiting Values.....	7	10.4 Electrostatic Discharge Caution.....	31
6.9 Electrical Characteristics.....	8	10.5 Glossary.....	31
6.10 Switching Characteristics.....	10	<b>11 Mechanical, Packaging, and Orderable Information</b> .....	32
<b>7 Parameter Measurement Information</b> .....	11		

## 4 Revision History

NOTE: Page numbers for previous revisions may differ from page numbers in the current version.

<b>Changes from Revision A (November 2022) to Revision B (June 2023)</b>	<b>Page</b>
• Changed status from <i>Advance Information</i> to <i>Production Data</i> .....	1
• Updated integrated avalanche rated MOSFET description to include notes for withstand testing in Features section.....	1
• Added Energy Storage Systems (ESS) and updated links in Applications section.....	1
• Added reference to Layout Guidelines in the Avalanche Robustness section.....	13
• Updated Layout Guidelines to include further EMI considerations and clarified the high voltage and thermal considerations.....	22
• Updated EVM images in Layout Example section to show the secondary side metallization for optimized thermals.....	23
• Added <a href="#">Interlayer Stitch Capacitance Option for EMI and Thermal Optimization</a> in Layout Example section...	23

## 5 Pin Configuration and Functions

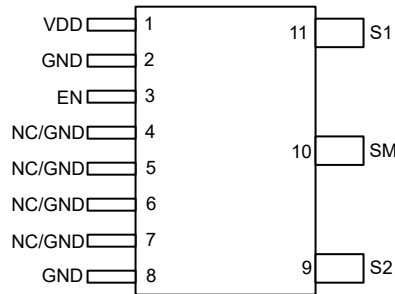

**Figure 5-1. TPSI2140-Q1 DWQ Package, 11-Pin SOIC (Top View)**

### 5.1 Pin Functions

PIN NO.	PIN NAME	TYPE <sup>(1)</sup>	DESCRIPTION
1	VDD	P	Power supply for primary side
2	GND	GND	Ground supply for primary side
3	EN	I	Active high switch enable signal
4	NC/GND	NC/GND	Internally connected, connect externally to ground or leave floating
5	NC/GND	NC/GND	Internally connected, connect externally to ground or leave floating
6	NC/GND	NC/GND	Internally connected, connect externally to ground or leave floating
7	NC/GND	NC/GND	Internally connected, connect externally to ground or leave floating
8	GND	GND	Internally connected to GND, connect externally to ground or leave floating
9	S2	I/O	Switch input
10	SM	NC	For thermal dissipation only, see Layout Guidelines for more information
11	S1	I/O	Switch input

(1) P = power, I = input, O = output, GND = ground, NC = no connect

## 6 Specifications

### 6.1 Absolute Maximum Ratings

over operating free-air temperature range (unless otherwise noted)<sup>(1)</sup>

PARAMETER		MIN	MAX	UNIT
V <sub>VDD</sub>	Primary side supply voltage <sup>(2)</sup>	−0.3	20.7	V
V <sub>EN</sub>	Enable voltage <sup>(2)</sup>	−0.3	20.7	V
I <sub>S1,S2</sub>	Switch current, S1/S2	−55	55	mA
I <sub>AVA,S1,S2</sub>	Repetitive avalanche rating, 5s pulse, S1/S2 <sup>(3)</sup>	−2	2	mA
	Repetitive avalanche rating, 60s pulse, S1/S2 <sup>(4)</sup>	−1	1	mA
T <sub>J</sub>	Junction temperature	−40	150	°C
T <sub>stg</sub>	Storage temperature	−65	150	°C

- (1) Operation outside the Absolute Maximum Ratings may cause permanent device damage. Absolute Maximum Ratings do not imply functional operation of the device at these or any other conditions beyond those listed under Recommended Operating Conditions. If used outside the Recommended Operating Conditions but within the Absolute Maximum Ratings, the device may not be fully functional, and this may affect device reliability, functionality, performance, and shorten the device lifetime.
- (2) Voltage values are with respect to GND.
- (3) 5 minutes accumulated over lifetime in increments of no longer than 5 second periods, duty cycle < 33%
- (4) 5 minutes accumulated over lifetime in increments of no longer than 60 second periods, duty cycle < 10%

### 6.2 ESD Ratings

			VALUE	UNIT	
HBM <sub>Prim</sub>	Electrostatic discharge	Human body model (HBM), per AEC Q100-002 <sup>(1)</sup> HBM ESD Classification Level 2	Primary Side Pins No. 1-8	±2000	V
HBM <sub>Sec</sub>		Human body model (HBM), per AEC Q100-002 <sup>(1)</sup> HBM ESD Classification Level 1C	Secondary Side Pins No. 9-11	±1500	V
CDM	Electrostatic discharge	Charged device model (CDM), per AEC Q100-011 CDM ESD Classification Level C4	All pins	±750	V

- (1) AEC Q100-002 indicates that HBM stressing must be in accordance with the ANSI/ESDA/JEDEC JS-001 specification.

### 6.3 Recommended Operating Conditions

over operating free-air temperature range (unless otherwise noted)

PARAMETER		MIN	NOM	MAX	UNIT
V <sub>VDD</sub>	Primary side supply voltage <sup>(1)</sup>	4.5		20	V
V <sub>EN</sub>	Enable voltage <sup>(1)</sup>	0		20	V
V <sub>S2-S1</sub>	Switch input voltage	-1200		1200	V
I <sub>S1,S2</sub>	Switch current	-50		50	mA
T <sub>A</sub>	Ambient operating temperature	-40		125	°C
T <sub>J</sub>	Junction operating temperature	-40		150	°C

(1) Voltage values are with respect to GND.

### 6.4 Thermal Information

THERMAL METRIC <sup>(1)</sup>		DEVICE		UNIT
		DWQ (SOIC)		
		11 PINS		
R <sub>θJA</sub>	Junction-to-ambient thermal resistance	70		°C/W
R <sub>θJA, EVM, 60S</sub>	Junction-to-ambient thermal resistance <sup>(2) (3)</sup>	52		°C/W
R <sub>θJA, EVM, 5S</sub>	Junction-to-ambient thermal resistance <sup>(2) (4)</sup>	30		°C/W
R <sub>θJB</sub>	Junction-to-board thermal resistance	22		°C/W
R <sub>θJC(top)</sub>	Junction-to-case (top) thermal resistance	26		°C/W
Ψ <sub>JT</sub>	Junction-to-top characterization parameter	14		°C/W
Ψ <sub>JB</sub>	Junction-to-board characterization parameter	21		°C/W

- (1) For more information about traditional and new thermal metrics, see the [Semiconductor and IC Package Thermal Metrics](#) application report.
- (2) EVM PCB dimensions are 74.25mm x 43mm x 1mm. 4 layer PCB with 2oz Cu on layers 1,4 and 1oz Cu on layer 2,3.
- (3) Performance of EVM with power applied for 60s.
- (4) Performance of EVM with power applied for 5s.

### 6.5 Power Ratings

PARAMETER		TEST CONDITIONS	MIN	TYP	MAX	UNIT
P <sub>D</sub>	Maximum power dissipation, total	V <sub>VDD</sub> = 5 V, V <sub>EN</sub> = 5 V peak to peak, V <sub>S1-S2</sub> = 1200V, R <sub>S1</sub> = 500kΩ f <sub>EN</sub> = 1Hz square wave			31	mW
P <sub>D_P</sub>	Maximum power dissipation (primary)				30	mW
P <sub>D_S</sub>	Maximum power dissipation (secondary)				1	mW

## 6.6 Insulation Specifications

PARAMETER		TEST CONDITIONS	VALUE	UNIT
<b>IEC 60664-1</b>				
CLR	External clearance <sup>(1)</sup>	Shortest terminal-to-terminal distance through air	>8	mm
CPG	External Creepage <sup>(1)</sup>	Shortest terminal-to-terminal distance across the package surface	>8	mm
DTI	Distance through the insulation	Minimum internal gap (internal clearance)	>10.5	μm
CTI	Comparative tracking index	DIN EN 60112 (VDE 0303-11); IEC 60112	>600	V
	Material Group	According to IEC 60664-1	I	
	Overvoltage category per IEC 60664-1	Rated mains voltage ≤ 300 V <sub>RMS</sub>	I-IV	
		Rated mains voltage ≤ 600 V <sub>RMS</sub>	I-III	
		Rated mains voltage ≤ 1000 V <sub>RMS</sub>	I-II	
<b>DIN V VDE 0884-11:2017-01<sup>(2)</sup>, IEC 60747-17:2020</b>				
V <sub>IORM</sub>	Maximum repetitive peak isolation voltage	AC voltage (bipolar)	1414	V <sub>PK</sub>
V <sub>IOWM</sub>	Maximum isolation working voltage	AC voltage (sine wave)	1000	V <sub>RMS</sub>
		DC voltage	1500	V <sub>DC</sub>
V <sub>IOTM</sub>	Maximum transient isolation voltage	V <sub>TEST</sub> = V <sub>IOTM</sub> , t = 60 s (qualification)	5300	V <sub>PK</sub>
		V <sub>TEST</sub> = 1.2 × V <sub>IOTM</sub> , t = 1 s (100% production)	6360	V <sub>PK</sub>
V <sub>IOSM</sub>	Maximum surge isolation voltage <sup>(3)</sup>	Tested in oil per IEC 62638-1, 1.2/50 μs waveform, V <sub>TEST</sub> = 1.3 × V <sub>IOSM</sub> = 6500 V <sub>PK</sub> (qualification)	5000	V <sub>PK</sub>
q <sub>pd</sub>	Apparent charge <sup>(4)</sup>	Method a: After I/O safety test subgroup 2/3, V <sub>ini</sub> = V <sub>IOTM</sub> , t <sub>ini</sub> = 60 s; V <sub>pd(m)</sub> = 1.2 × V <sub>IORM</sub> = 1800 V <sub>PK</sub> , t <sub>m</sub> = 10 s	≤5	pC
		Method a: After environmental tests subgroup 1, V <sub>ini</sub> = V <sub>IOTM</sub> , t <sub>ini</sub> = 60 s; V <sub>pd(m)</sub> = 1.3 × V <sub>IORM</sub> = 1950 V <sub>PK</sub> , t <sub>m</sub> = 10 s	≤5	
		Method b1: At routine test (100% production) and preconditioning (type test), V <sub>ini</sub> = V <sub>IOTM</sub> , t <sub>ini</sub> = 1 s; V <sub>pd(m)</sub> = 1.5 × V <sub>IORM</sub> = 2250 V <sub>PK</sub> , t <sub>m</sub> = 1 s	≤5	
C <sub>IO</sub>	Barrier capacitance, input to output <sup>(5)</sup>	V <sub>IO</sub> = 0.4 × sin(2πft), f = 1 MHz	4	pF
R <sub>IO</sub>	Insulation resistance, input to output <sup>(5)</sup>	V <sub>IO</sub> = 500 V, T <sub>A</sub> = 25°C	>10 <sup>12</sup>	Ω
		V <sub>IO</sub> = 500 V, 100°C ≤ T <sub>A</sub> ≤ 125°C	>10 <sup>11</sup>	
		V <sub>IO</sub> = 500 V at T <sub>S</sub> = 150°C	>10 <sup>9</sup>	
	Pollution degree		2	
	Climatic category		40/150/21	
<b>UL 1577</b>				
V <sub>ISO</sub>	Withstand isolation voltage	V <sub>TEST</sub> = V <sub>ISO</sub> , t = 60 s (qualification)	3750	V <sub>RMS</sub>
		V <sub>TEST</sub> = 1.2 × V <sub>ISO</sub> , t = 1 s (100% production)		
<b>Misc.</b>				
V <sub>ISO</sub>	Withstand isolation voltage		5300	V <sub>DC</sub>

- Creepage and clearance requirements should be applied according to the specific equipment isolation standards of an application. Care should be taken to maintain the creepage and clearance distance of a board design to ensure that the mounting pads of the isolator on the printed-circuit board do not reduce this distance. Creepage and clearance on a printed-circuit board become equal in certain cases. Techniques such as inserting grooves, ribs, or both on a printed-circuit board are used to help increase these specifications.
- This coupler is suitable for *safe electrical insulation* only within the safety ratings. Compliance with the safety ratings shall be ensured by means of suitable protective circuits.
- Testing is carried out in air or oil to determine the intrinsic surge immunity of the isolation barrier.
- Apparent charge is electrical discharge caused by a partial discharge (pd).
- All pins on each side of the barrier tied together creating a two-pin device.

## 6.7 Safety-Related Certifications

VDE	CSA	UL	CQC	TUV
Plan to certify according to DIN V VDE V 0884-11:2017-01	Not Planned, contact TI to request.	Plan to certify according to UL 1577 Component Recognition Program	Not Planned, contact TI to request.	Not Planned, contact TI to request.
Maximum transient isolation voltage, 5300 V <sub>PK</sub> ; Maximum repetitive peak isolation voltage, 1500 V <sub>PK</sub> ; Maximum surge isolation voltage, 6000 V <sub>PK</sub>		Single protection, 3750 V <sub>RMS</sub>		
Certificate planned		Certificate planned		

## 6.8 Safety Limiting Values

PARAMETER <sup>(1) (2)</sup>		TEST CONDITIONS	MIN	TYP	MAX	UNIT
I <sub>S</sub>	Safety VDD Current	R <sub>θJA</sub> = 70°C/W, V <sub>VDD</sub> = 20 V, T <sub>J</sub> = 150°C, T <sub>A</sub> = 25°C			77	mA
	Safety Switch Current (On State)	R <sub>θJA</sub> = 70°C/W, V <sub>VDD</sub> = 20 V, T <sub>J</sub> = 150°C, T <sub>A</sub> = 25°C			71	
	Safety Switch Current (Off State, 5 second)	R <sub>θJA, EVM, 5S</sub> <sup>(3)</sup> = 30°C/W, V <sub>VDD</sub> = 0 V, T <sub>J</sub> = 150°C, T <sub>A</sub> = 25°C			2.7	
	Safety Switch Current (Off State, 60 second)	R <sub>θJA, EVM, 60S</sub> <sup>(3)</sup> = 52°C/W, V <sub>VDD</sub> = 0 V, T <sub>J</sub> = 150°C, T <sub>A</sub> = 25°C			1.5	
P <sub>S</sub>	Safety input, output, or total power	R <sub>θJA</sub> = 70°C/W, T <sub>J</sub> = 150°C, T <sub>A</sub> = 25°C.			1.78	W
T <sub>S</sub>	Maximum safety temperature				150	°C

- (1) Safety limiting intends to minimize potential damage to the isolation barrier upon failure of input or output circuitry. A failure of the I/O can allow low resistance to ground or the supply and, without current limiting, dissipate sufficient power to overheat the die and damage the isolation barrier, potentially leading to secondary system failures.
- (2) The safety-limiting constraint is the maximum junction temperature specified in the data sheet. The power dissipation and junction-to-air thermal impedance of the device installed in the application hardware determines the junction temperature. The assumed junction-to-air thermal resistance in the [Thermal Information](#) table is that of a device installed on a high-K test board for leaded surface-mount packages. The power is the recommended maximum input voltage times the current. The junction temperature is then the ambient temperature plus the power times the junction-to-air thermal resistance.
- (3) Assuming PCB layout similar to EVM in Layout Guideline section.

## 6.9 Electrical Characteristics

Unless otherwise noted, all minimum/maximum specifications are over recommended operating conditions. All typical values are measured at  $T_J = 25^\circ\text{C}$ ,  $V_{VDD} = 5\text{V}$ ,  $V_{EN} = 5\text{V}$ .

PARAMETER		TEST CONDITIONS	MIN	TYP	MAX	UNIT
<b>PRIMARY SIDE SUPPLY (VDD)</b>						
$V_{UVLO\_R}$	VDD undervoltage threshold rising	VDD rising	4	4.2	4.4	V
$V_{UVLO\_F}$	VDD undervoltage threshold falling	VDD falling	3.9	4.1	4.3	V
$V_{UVLO\_HYS}$	VDD undervoltage threshold hysteresis		40	100	150	mV
$I_{VDD\_ON}$	VDD current, device powered on	$T_J = 25^\circ\text{C}$		9	11	mA
	VDD current, device powered on	$-40^\circ\text{C} \leq T_J \leq 150^\circ\text{C}$		9	12	mA
$I_{VDD\_OFF}$	VDD current, 5 V, device powered off	$V_{VDD} = 5\text{V}$ , $V_{EN} = 0\text{V}$ , $T_J = 25^\circ\text{C}$		3.5	8	$\mu\text{A}$
		$V_{VDD} = 5\text{V}$ , $V_{EN} = 0\text{V}$ , $T_J = 105^\circ\text{C}$		4.5	11	$\mu\text{A}$
		$V_{VDD} = 5\text{V}$ , $V_{EN} = 0\text{V}$ , $T_J = 125^\circ\text{C}$		5.2	16	$\mu\text{A}$
		$V_{VDD} = 5\text{V}$ , $V_{EN} = 0\text{V}$ , $-40^\circ\text{C} \leq T_J \leq 150^\circ\text{C}$			30	$\mu\text{A}$
	VDD current, 20 V, device powered off	$V_{VDD} = 20\text{V}$ , $V_{EN} = 0\text{V}$ , $T_J = 25^\circ\text{C}$		8	10.5	$\mu\text{A}$
		$V_{VDD} = 20\text{V}$ , $V_{EN} = 0\text{V}$ , $T_J = 105^\circ\text{C}$		10	17	
		$V_{VDD} = 20\text{V}$ , $V_{EN} = 0\text{V}$ , $T_J = 125^\circ\text{C}$		11	25	
		$V_{VDD} = 20\text{V}$ , $V_{EN} = 0\text{V}$ , $-40^\circ\text{C} \leq T_J \leq 150^\circ\text{C}$			40	
<b>FET CHARACTERISTICS (S1, S2)</b>						
$R_{DSON}$	On resistance	$I_O = 2\text{mA}$ , $T_J = 25^\circ\text{C}$		130	175	$\Omega$
		$I_O = 2\text{mA}$ , $T_J = 85^\circ\text{C}$		176	235	
		$I_O = 2\text{mA}$ , $T_J = 105^\circ\text{C}$		192	250	
		$I_O = 2\text{mA}$ , $T_J = 125^\circ\text{C}$		210	275	
		$I_O = 2\text{mA}$ , $-40^\circ\text{C} \leq T_J \leq 150^\circ\text{C}$			300	
$I_{OFF}$	Off leakage, 1200 V	$V = \pm 1200\text{V}$ , $T_J = 25^\circ\text{C}$		0.02	0.1	$\mu\text{A}$
		$V = \pm 1200\text{V}$ , $T_J = 85^\circ\text{C}$			0.5	
		$V = \pm 1200\text{V}$ , $T_J = 105^\circ\text{C}$			1.5	
		$V = \pm 1200\text{V}$ , $T_J = 125^\circ\text{C}$			6	
		$V = \pm 1200\text{V}$ , $-40^\circ\text{C} \leq T_J \leq 150^\circ\text{C}$			50	
	Off leakage, 1000 V	$V = \pm 1000\text{V}$ , $T_J = 25^\circ\text{C}$		0.02	0.1	$\mu\text{A}$
		$V = \pm 1000\text{V}$ , $T_J = 85^\circ\text{C}$			0.3	
		$V = \pm 1000\text{V}$ , $T_J = 105^\circ\text{C}$			1	
		$V = \pm 1000\text{V}$ , $T_J = 125^\circ\text{C}$			4	
		$V = \pm 1000\text{V}$ , $-40^\circ\text{C} \leq T_J \leq 150^\circ\text{C}$			35	
$V_{AVA}$	Avalanche voltage	$I_O = 10\mu\text{A}$ , $T_J = 25^\circ\text{C}$	1300	1550		V
		$I_O = 100\mu\text{A}$ , $T_J = 150^\circ\text{C}$	1300	1550		
$V_{SM\_OFF}$	SM voltage	$V_{S1} = 1000\text{V}$ , $V_{S2} = 0\text{V}$ OR $V_{S2} = 1000\text{V}$ , $V_{S1} = 0\text{V}$	400		600	V
$C_{OSS}$	S1, S2 capacitance	$V_{S1,S2} = 0\text{V}$ , SM float, $F = 1\text{MHz}$		75		pF
<b>LOGIC-LEVEL INPUT (EN)</b>						
$V_{IL}$	Input logic low voltage		0.0		0.8	V
$V_{IH}$	Input logic high voltage		2.1		20.0	V
$V_{HYS}$	Input logic hysteresis		100	250	300	mV
$I_{IL}$	Input logic low current	$V_{EN} = 0\text{V}$	-0.1		0.1	$\mu\text{A}$
$I_{IL}$	Input logic low current	$V_{EN} = 0.8\text{V}$	2	4	6.5	$\mu\text{A}$

## 6.9 Electrical Characteristics (continued)

Unless otherwise noted, all minimum/maximum specifications are over recommended operating conditions. All typical values are measured at  $T_J = 25^\circ\text{C}$ ,  $V_{VDD} = 5\text{V}$ ,  $V_{EN} = 5\text{V}$ .

PARAMETER		TEST CONDITIONS	MIN	TYP	MAX	UNIT
$I_{IH}$	Input logic high current	$V_{EN} = 5\text{ V}$	10	22	50	$\mu\text{A}$
$I_{IH}$	Input logic high current	$V_{EN} = 20\text{ V}$	100	175	350	$\mu\text{A}$
$I_{VDD\_FS}$	VDD fail-safe current	$V_{EN} = 20\text{ V}$ , $V_{VDD} = 0\text{ V}$	-0.1		0.1	$\mu\text{A}$
$R_{PD}$	Pulldown resistance	Two point measurement, $V_{EN} = 0.5\text{ V}$ and $V_{EN} = 0.8\text{ V}$	100	200	350	$\text{k}\Omega$
<b>NOISE IMMUNITY</b>						
CMTI	Common-mode transient immunity	$ V_{CM}  = 1000\text{ V}$			100.0	V/ns

## 6.10 Switching Characteristics

Unless otherwise noted, all minimum/maximum specifications are over recommended operating conditions. All typical values are measured at  $T_A = 25^\circ\text{C}$ ,  $V_{\text{VDD}} = 5\text{V}$ ,  $V_{\text{EN}} = 5\text{V}$ .

MODE	PARAMETER	TEST CONDITIONS	MIN	TYP	MAX	UNIT
<b>Switching Characteristics</b>						
EN switching	$t_{\text{PD\_ON}}$	Input HI to Output voltage falling propagation delay	$V_{\text{IN}} = 1000\text{ V}$ $R_{\text{L}} = 1\text{ M}\Omega$	100	300	$\mu\text{s}$
	$t_{\text{F}}$	Output fall time		20	100	
	$t_{\text{ON}}$	Input HI to Output LO delay		160	400	
	$t_{\text{PD\_OFF}}$	Input LO to Output voltage rising propagation delay		150	200	
	$t_{\text{R}}$	Output rise time		50	600	
	$t_{\text{OFF}}$	Input LO to Output HI delay		200	700	
EN and VDD switching	$t_{\text{PD\_ON}}$	Input HI to Output voltage falling propagation delay	$V_{\text{IN}} = 1000\text{ V}$ $R_{\text{L}} = 1\text{ M}\Omega$	240	400	$\mu\text{s}$
	$t_{\text{F}}$	Output fall time		20	100	
	$t_{\text{ON}}$	Input HI to Output LO delay		260	500	
	$t_{\text{PD\_OFF}}$	Input LO to Output voltage rising propagation delay		150	200	
	$t_{\text{R}}$	Output rise time		50	600	
	$t_{\text{OFF}}$	Input LO to Output HI delay		200	700	

## 7 Parameter Measurement Information

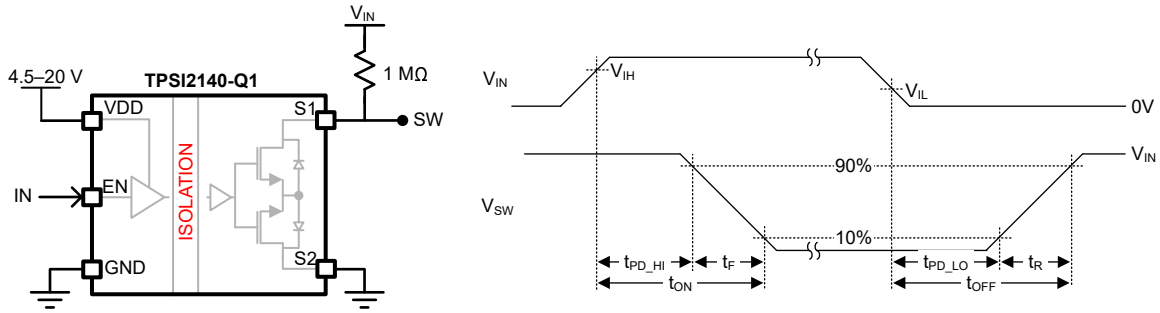

**Figure 7-1. Timing Diagram, EN Switching**

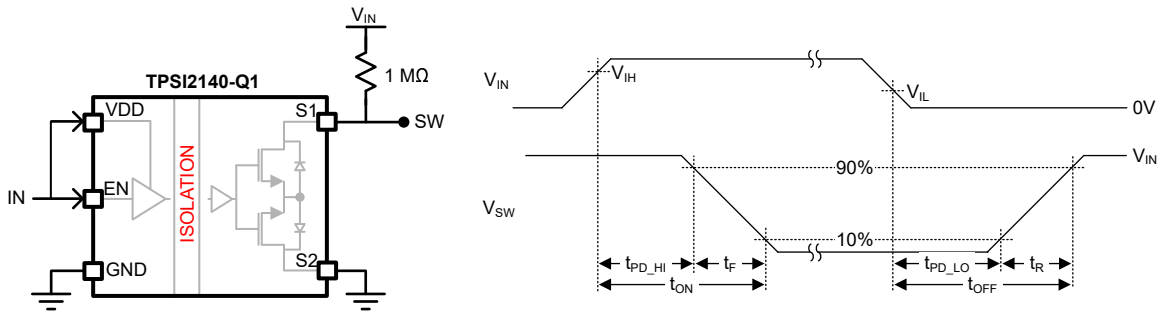

**Figure 7-2. Timing Diagram, EN and VDD Switching**

## 8 Detailed Description

### 8.1 Overview

The TPSI2140-Q1 is an isolated solid state relay designed for high voltage automotive and industrial applications. TI's high reliability capacitive isolation technology in combination with back-to-back MOSFETs form a completely integrated solution requiring no secondary side power supply.

As seen in the [Functional Block Diagram](#), the primary side consists of a driver which delivers power and enable logic information to each of the internal MOSFETs on the secondary side. The on-board oscillator controls the frequency of the driver's operation and the Spread Spectrum Modulation (SSM) controller varies the driver frequency to improve system EMI performance. When the enable pin is brought HI and the VDD voltage is above the UVLO threshold, the oscillator starts and the driver sends power and a logic HI across the barrier. When the enable pin is brought LO or the VDD voltage falls below the UVLO threshold, the driver is disabled. The lack of activity communicates a logic LO to the secondary side and the MOSFETs are disabled.

Each MOSFET on the secondary side has a dedicated full-bridge rectifier to form its local power supply and a receiver. The receiver determines the logic state delivered from the primary side through the capacitive isolation barrier and uses a slew rate controlled driver to drive the MOSFET's gate. Each receiver performs signal conditioning on the signals received across the barrier in order to filter common mode interference and ensure that the MOSFETs are controlled according to the logic sent by the primary side driver and the system.

The avalanche robust MOSFETs and the thermal benefits of the widened pins on the 11 DWQ package enable the TPSI2140-Q1 to support dielectric withstand testing (HiPot) and DC fast charger surge currents of up to 2 mA without requiring any external protection components.

### 8.2 Functional Block Diagram

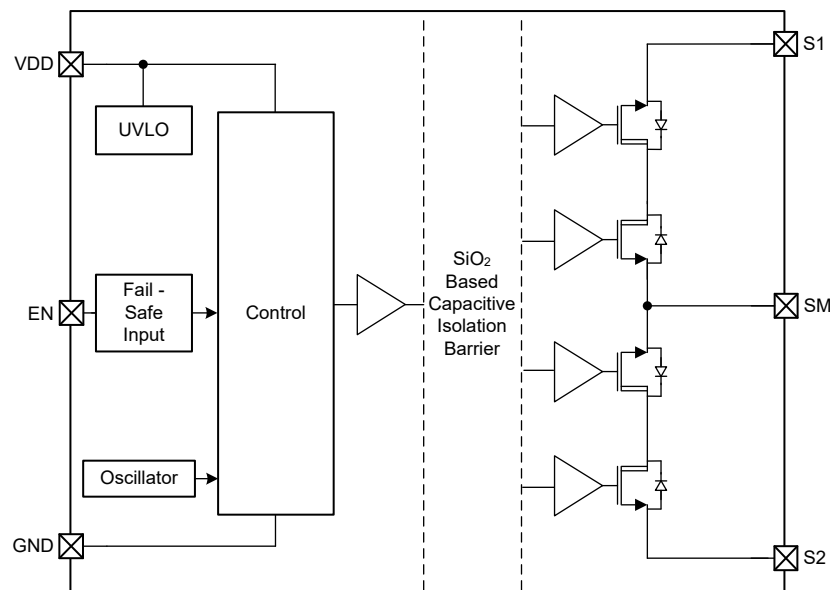

Figure 8-1. TPSI2140-Q1 Block Diagram

## 8.3 Feature Description

### 8.3.1 Avalanche Robustness

When the voltage between the S1 and S2 pins exceeds +/-1200 V the secondary side MOSFETs could enter an avalanche mode of operation. The MOSFETs and the 11 DWQ package have been designed and qualified to be robust in this mode of operation to support [Dielectric Withstand Testing \(HiPot\)](#). To help ensure the thermal performance of the the system in this mode of operation, refer to the PCB [Layout Guidelines](#).

## 8.4 Device Functional Modes

**Table 8-1. Device Functional Modes**

VDD	EN	S1-S2 State	COMMENTS
Powered Up <sup>(1)</sup>	L	OFF	VDD current is in OFF state range.
	H	ON	VDD current is in ON state range.
Powered Down <sup>(2)</sup>	L	OFF	VDD current is in OFF state range.
	H	OFF	Primary side analog is powered on, VDD current is between OFF state and ON state ranges.

(1) VDD ≥ VDD undervoltage rising threshold.

(2) VDD ≤ VDD undervoltage falling threshold.

## 9 Application and Implementation

### Note

Information in the following applications sections is not part of the TI component specification, and TI does not warrant its accuracy or completeness. TI's customers are responsible for determining suitability of components for their purposes, as well as validating and testing their design implementation to confirm system functionality.

### 9.1 Application Information

The TPSI2140-Q1 is a 1200-V, 50-mA automotive isolated switch optimized for high voltage switching in measurement applications, especially those that require switching across an isolation barrier or galvanically isolated domain. Common end equipments include energy storage systems (ESS), solar panel arrays, EV chargers, and EV battery management systems. The device enables the system designer to reduce cost and improve reliability by replacing mechanical relays and optically isolated devices.

The TPSI2140-Q1's enable input is fail safe and does not need to be driven from the same domain as the VDD pin supply.

The TPSI2140-Q1 supports an input voltage range of 4.5 V to 20 V on the VDD primary supply pin and a logic high of 2.1 V to 20 V on the enable pin. The secondary side supports high voltage switching from –1200 V to 1200 V.

### TI Reference Designs

The TI reference designs linked below are a helpful introduction to high voltage applications using the TPSI2140-Q1. To maximize the thermal performance of the TPSI2140-Q1 for dielectric withstand testing (HiPot), please follow the [Layout Guidelines](#) contained within this datasheet.

- [TIDA-010232: High Voltage Insulation Monitoring](#)
- [TIDA-01513: Automotive High Voltage and Isolation Leakage Measurements](#)

### 9.2 Typical Application

#### Insulation Resistance Monitoring

In high voltage applications such as electric vehicle systems, the high voltage battery pack is intentionally isolated from the chassis domain of the car to protect the driver and prevent damage to electrical components. These systems actively monitor the integrity of this insulation to ensure the safety of the system throughout its lifetime. This active monitoring is referred to as insulation resistance monitoring (also known as isolation check, insulation check, isolation monitoring, insulation monitoring, and residual current monitoring (RCM)) and is performed by measuring the resistances from each of the battery terminals to the chassis ground, illustrated below as  $R_{ISOP}$  and  $R_{ISON}$ .

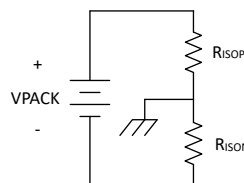

**Figure 9-1. Insulation Resistance Model**

There are multiple design architectures using the TPSI2140-Q1 to measure these insulation resistances,  $R_{ISOP}$  and  $R_{ISON}$ . Some architectures employ a microcontroller that performs measurements from the high voltage

domain, which will be referred to in this document as the Battery V- Reference architecture. Others use a microcontroller in the low voltage domain, which will be referred to in this document as the Chassis Ground Reference architecture. The primary difference between the two architectures is the node that the MCU uses as its GND reference. An example of a Battery V- MCU is the [BQ79631-Q1 UIR sensor](#).

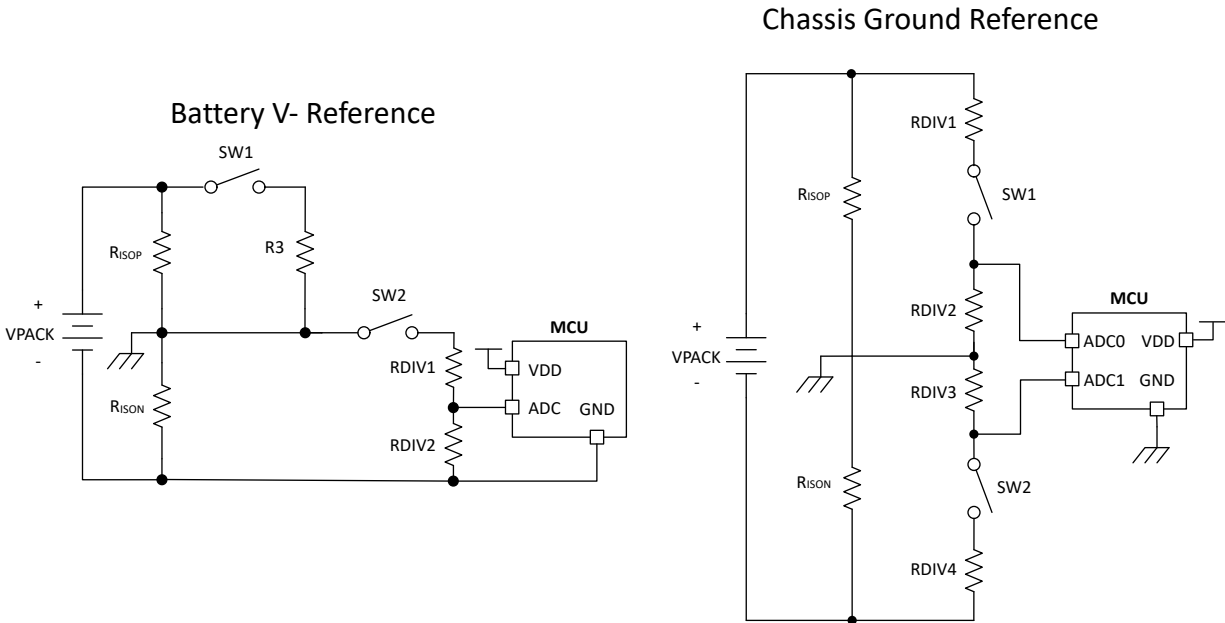

Figure 9-2. Different MCU ADC Reference Examples

The two following sections demonstrate the measurement algorithms and the systems of equations used to calculate the isolation resistances using each architecture.

### Battery V- Reference Example

A Battery V- Reference architecture is shown below with the TPSI2140-Q1 illustrated as a switch (SW1 and SW2). SW2 initiates a connection between the chassis and PACK- and enables the measurement path to the ADC. SW1 initiates a connection between the chassis and the PACK+. RDIV1 and RDIV2 form a divider which scales the measured voltages down to the appropriate ADC range.

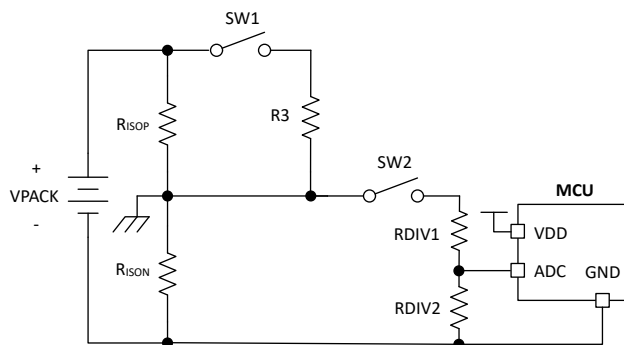

Figure 9-3. Battery V- Reference Architecture

Two ADC measurements must be taken in order to obtain enough information to calculate the two unknown isolation resistances. The first measurement is taken with SW1 open and SW2 closed. The second measurement is taken with SW1 closed and SW2 closed. With these two measurements it is possible to solve the system of equations and calculate  $R_{ISOP}$  and  $R_{ISON}$ .

In the following example the voltage on the chassis ground is arbitrarily referred to as  $V_{RISONx}$ .

For the first ADC measurement SW2 is closed as shown below and the following equations relate the ADC voltage to the other parameters in the system in this condition:

- $V_{ADC1}$  measurement 1: SW1 open, SW2 closed

$$V_{RISON1} = V_{PACK} \times \frac{R_{ISON} || (R_{DIV1} + R_{DIV2})}{R_{ISOP} + (R_{ISON} || (R_{DIV1} + R_{DIV2}))} \quad (1)$$

$$V_{ADC1} = V_{RISON1} \times \frac{R_{DIV2}}{R_{DIV1} + R_{DIV2}} \quad (2)$$

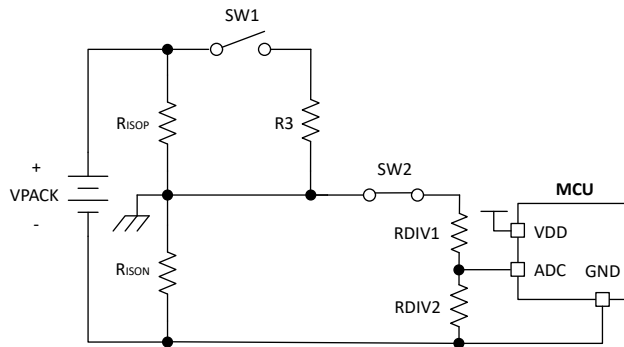

**Figure 9-4. Battery V- Reference Switch Positions for ADC1 Measurement**

For the second ADC measurement SW1 and SW2 are closed as shown below and the following equations relate the ADC voltage to the other parameters in the system in this condition:

- $V_{ADC2}$  measurement 2: SW1 closed, SW2 closed

$$V_{RISON2} = V_{PACK} \times \frac{R_{ISON} || (R_{DIV1} + R_{DIV2})}{(R_{ISOP} || R_3) + (R_{ISON} || (R_{DIV1} + R_{DIV2}))} \quad (3)$$

$$V_{ADC2} = V_{RISON2} \times \frac{R_{DIV2}}{R_{DIV1} + R_{DIV2}} \quad (4)$$

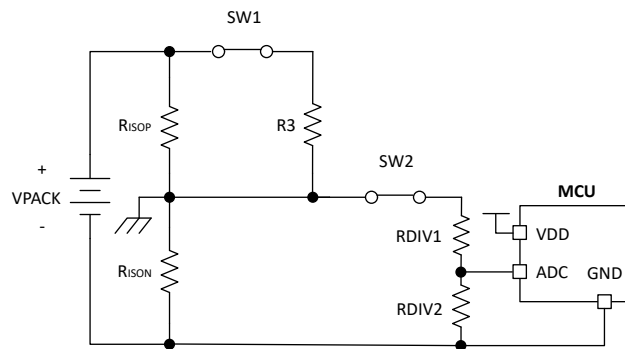

**Figure 9-5. Battery V- Reference Switch Positions for ADC2 Measurement**

### Chassis Ground Reference Example

A Chassis Ground Reference architecture is shown below. SW1 and SW2 initiate connections to the PACK+ and PACK-, and enable their corresponding measurement paths to their ADCs through their corresponding resistor dividers. RDIV1, RDIV2, RDIV3, and RDIV4 scale the measured voltages down to the appropriate ADC ranges.

This first measurement is taken with SW1 closed and SW2 open and the second measurement is taken with SW1 open and SW2 closed.

- VADC0: SW1 closed, SW2 open

$$V_{ADC1} = V_{RDIV2} = V_{PACK} \frac{(R_{ISOP} || (R_{DIV1} + R_{DIV2}))}{(R_{ISOP} || (R_{DIV1} + R_{DIV2}) + R_{ISON})} \times \frac{R_{DIV2}}{R_{DIV1} + R_{DIV2}} \quad (5)$$

- VADC1: SW1 open, SW2 closed

$$V_{ADC2} = V_{RDIV3} = -V_{PACK} \frac{(R_{ISON} || (R_{DIV3} + R_{DIV4}))}{(R_{ISON} || (R_{DIV3} + R_{DIV4}) + R_{ISOP})} \times \frac{R_{DIV3}}{R_{DIV3} + R_{DIV4}} \quad (6)$$

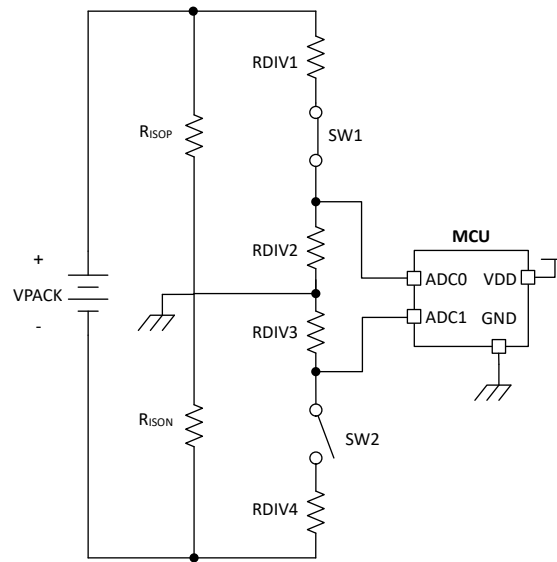

**Figure 9-6. Chassis Ground Reference Switch Positions for ADC1 Measurement**

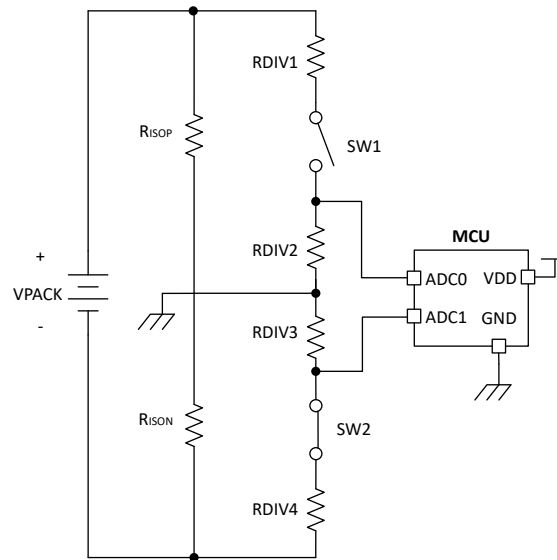

**Figure 9-7. Chassis Ground Reference Switch Positions for ADC2 Measurement**

### Battery V- Reference and Chassis Ground Reference Architectures with the TPSI2140-Q1

The circuits in [Figure 9-8](#) and [Figure 9-9](#) demonstrate how to connect the TPSI2140-Q1 as a switch in each of the architectures above.

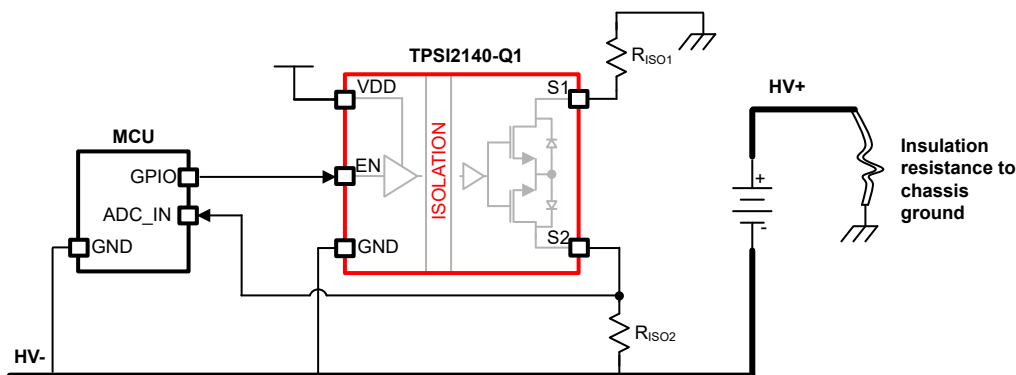

Figure 9-8. TPSI2140-Q1 Insulation Resistance Monitoring – Battery V- Reference

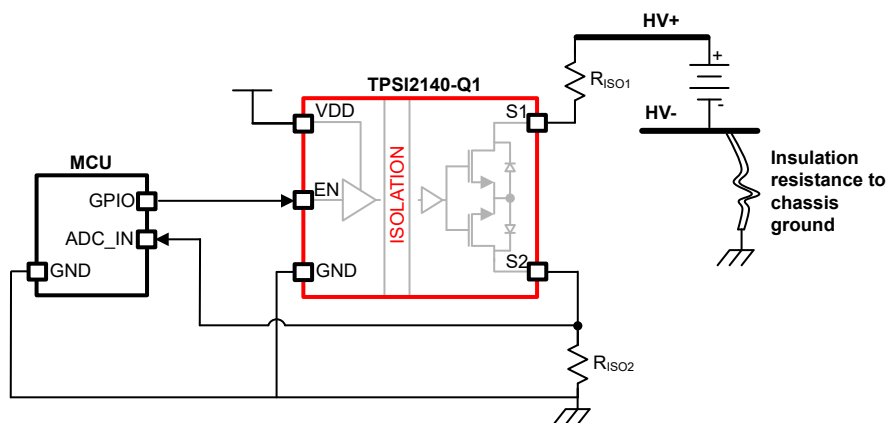

Figure 9-9. TPSI2140-Q1 Insulation Resistance Monitoring – Chassis Ground Reference

### 9.2.1 Dielectric Withstand Testing (HiPot)

The TPSI2140-Q1 is specifically designed to support dielectric withstand testing. In a high voltage system, a dielectric withstand test (HiPot) may be administered during the characterization, production or maintenance of the system to validate the reliability of the insulation barriers and galvanically isolated domains it contains. These withstand voltage tests intentionally stress the components spanning these domains and put them in an overvoltage condition. MOSFETs that are placed under these overvoltage conditions will enter avalanche mode and begin conducting current at a high voltage, dissipating high power and heating up. The design and qualification of the TPSI2140-Q1 was completed with this state in mind and supports up to 2 mA  $I_{AVA}$  for 5 seconds intervals and 1 mA  $I_{AVA}$  for 60 second intervals.

The dielectric withstand test voltage ( $V_{HiPot}$ ), the TPSI2140-Q1's avalanche voltage ( $V_{AVA}$ ), and the resistance (R) in series with the TPSI2140-Q1 should limit the avalanche current ( $I_{AVA}$ ) to the corresponding current limit depending on the test duration. In addition, the PCB design should follow the recommendations in the [Layout Guidelines](#) section to ensure adequate thermal performance to keep the junction temperature ( $T_J$ ) below the absolute maximum rating of the TPSI2140-Q1.

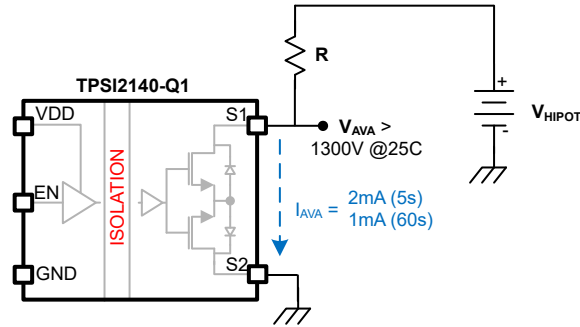

Figure 9-10. Dielectric Withstand Test (HiPot) - Simplified Schematic

## 9.2.2 Design Requirements

Table 9-1 lists the Design Requirements for a typical insulation resistance monitoring application using the Chassis Ground Reference architecture and the TPSI2140-Q1 for switching.

Table 9-1. Typical Design Parameters For Insulation Resistance Monitoring Using the TPSI2140-Q1 – Chassis Ground Reference Architecture

PARAMETER	VALUE
V <sub>PACK</sub> Voltage (maximum)	1000 V
Primary side supply (V <sub>VDD</sub> )	5 V ±10 %
Dielectric withstand voltage test	3500 V
	5 s
Surge voltage (IEC61000-3-5)	2500 V

## 9.2.3 Design Procedure - Chassis Ground Reference

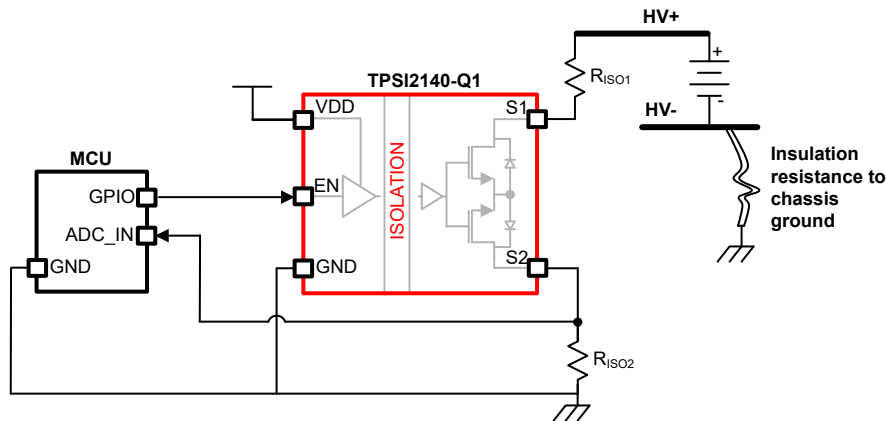

Figure 9-11. Chassis Ground Reference

### R<sub>ISO1</sub> Selection

In order to protect the TPSI2140-Q1, R<sub>ISO1</sub> must be sized to limit the current in an overvoltage condition. The amount of resistance required to protect the TPSI2140-Q1 depends on the amount of overvoltage applied. For example, during a dielectric withstand voltage test (HiPot) of 3500 V for 5 seconds, the S1 to S2 voltage will be clamped to 1300 V (V<sub>AVA</sub> minimum) by the TPSI2140-Q1 and the R<sub>ISO1</sub> resistance required to keep the current under 2 mA would be 1.1 MΩ.

$$I_{AVA} = \frac{V_{HIPOT} - V_{AVA}}{R_{ISO1}} = \frac{3500V - 1300V}{1.1 \text{ M}\Omega} = 2.0mA \quad (7)$$

If the high potential test lasts for 60 seconds, the  $R_{ISO1}$  resistance must be doubled to 2.2 M $\Omega$  to keep the current below 1 mA.

DC Overvoltage	$R_{ISO1}$ Minimum (5 second intervals)	$R_{ISO1}$ Minimum (60 second intervals)
2000 V	350 k $\Omega$	700 k $\Omega$
2500 V	600 k $\Omega$	1200 k $\Omega$
3500 V	1100 k $\Omega$	2200 k $\Omega$
4300 V	1500 k $\Omega$	3000 M $\Omega$

### 9.3 Power Supply Recommendations

To ensure a reliable supply voltage, TI recommends that a 100-nF ceramic capacitor be placed between the VDD pin and the GND pin of the TPSI2140-Q1. The capacitor should be placed as close to the device's VDD pin as possible < 10 mm.

### 9.4 Layout

#### 9.4.1 Layout Guidelines

##### Component placement:

Decoupling capacitors for the primary side VDD supply must be placed as close as possible to the device pins.

##### EMI considerations:

The TPSI2140-Q1 employs spread spectrum modulation (SSM) and in some systems, no additional system design considerations are required to meet the EMI performance needs.

However, the system designer may choose to take additional measures to minimize EMI depending on the system requirements and safety preferences of the system designer. The measures listed below reduce emissions by providing a capacitive return path from the secondary side to the primary side or by increasing the common mode loop impedance with an inductive component on the primary side.

- **Capacitive Return Paths:**

- An interlayer stitching capacitance in the range of 10-20 pF can be implemented on the PCB. This zero-cost implementation is typically preferred as it also serves the purpose of thermal performance improvement if placed directly underneath the TPSI2140-Q1. Please see the [Layout Example](#) for more details.
- Most system designs already employ discrete Y capacitors or contain an amount of parasitic Y capacitance between the high voltage and low voltage domains. If this Y capacitance is located on the same board as the TPSI2140-Q1, they will act as a capacitive return path.
- Discrete high voltage capacitors could also be placed between the GND pin and the S1 or S2 terminals.

- **Inductive Components:**

- A pair of ferrite beads or a common mode choke with a high frequency impedance in the range of 10 k $\Omega$  may be placed in series with the system VDD pin and GND pin supply on the primary side of the TPSI2140-Q1.

##### High-voltage considerations:

The creepage from the primary side to the secondary side and from the creepage from the S1 pin to S2 pin of the TPSI2140-Q1 should be maintained according to system requirements. It is most likely that the system designer will avoid any top layer PCB routing underneath the body of the package or between the S1 and S2 pins.

##### Thermal considerations:

If the system designer plans to use the TPSI2140-Q1 in avalanche mode, it is important for the PCB layout to be designed with thermal performance in mind. Proper PCB layout can help dissipate heat from the device to the PCB and keep the junction temperature ( $T_J$ ) under the absolute maximum rating. Floating inner layer planes

or the planes used to implement a stitch capacitor can be drawn beneath the secondary side pins or directly beneath the TPSI2140-Q1 for improved heat dissipation. An example of this can be seen in the [Layout Example](#).

### 9.4.2 Layout Example

Varying PCB implementations are possible depending on both the system EMI requirements and the system dielectric withstand testing (HiPot) parameters. The following sections detail the [TPSI2140-Q1 EVM with Thermal Optimization](#) with secondary side metallization for optimized thermal performance and the [Interlayer Stitch Capacitance Option for EMI and Thermal Optimization](#).

#### TPSI2140-Q1 EVM with Thermal Optimization

The TPSI2140-Q1 EVM images below demonstrate a secondary side thermal metallization pattern and internal floating metal that provides thermal relief to the TPSI2140-Q1 during system dielectric withstand testing (HiPot). The [TPSI2140-Q1 Secondary Side Layout Recommendation for Optimized Thermal Performance: Top Layer 1](#) shows the top side creepage and clearance considerations.

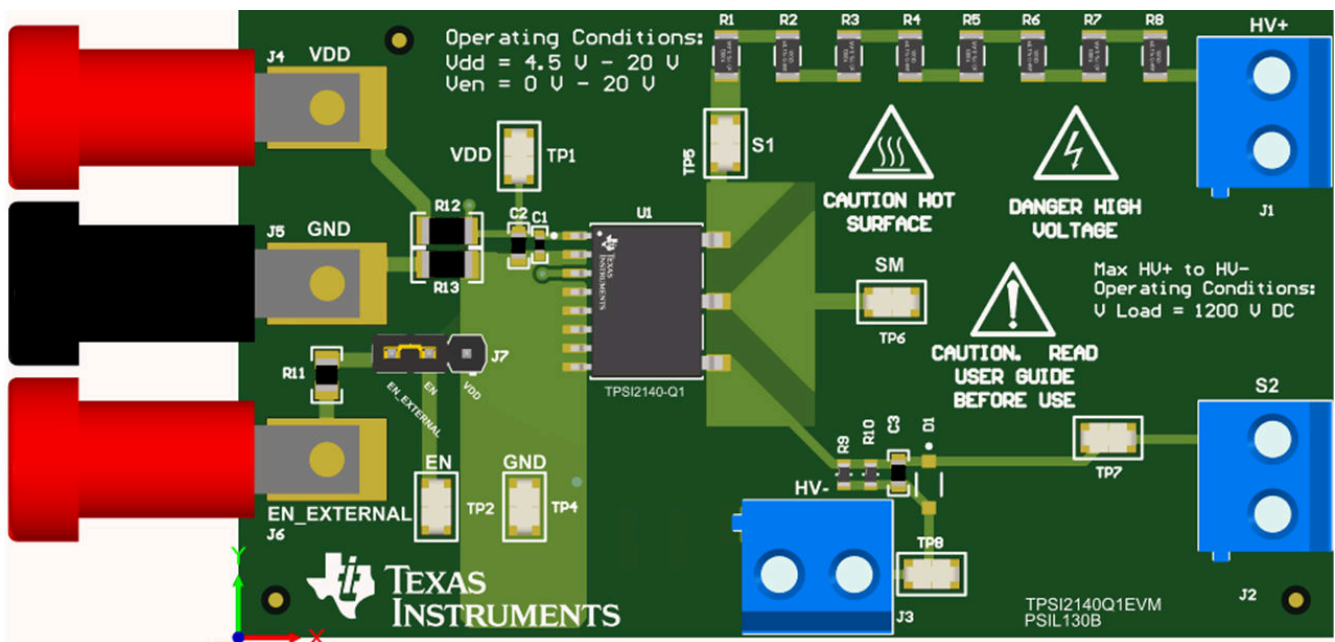

Figure 9-12. TPSI2140-Q1 EVM - Component View

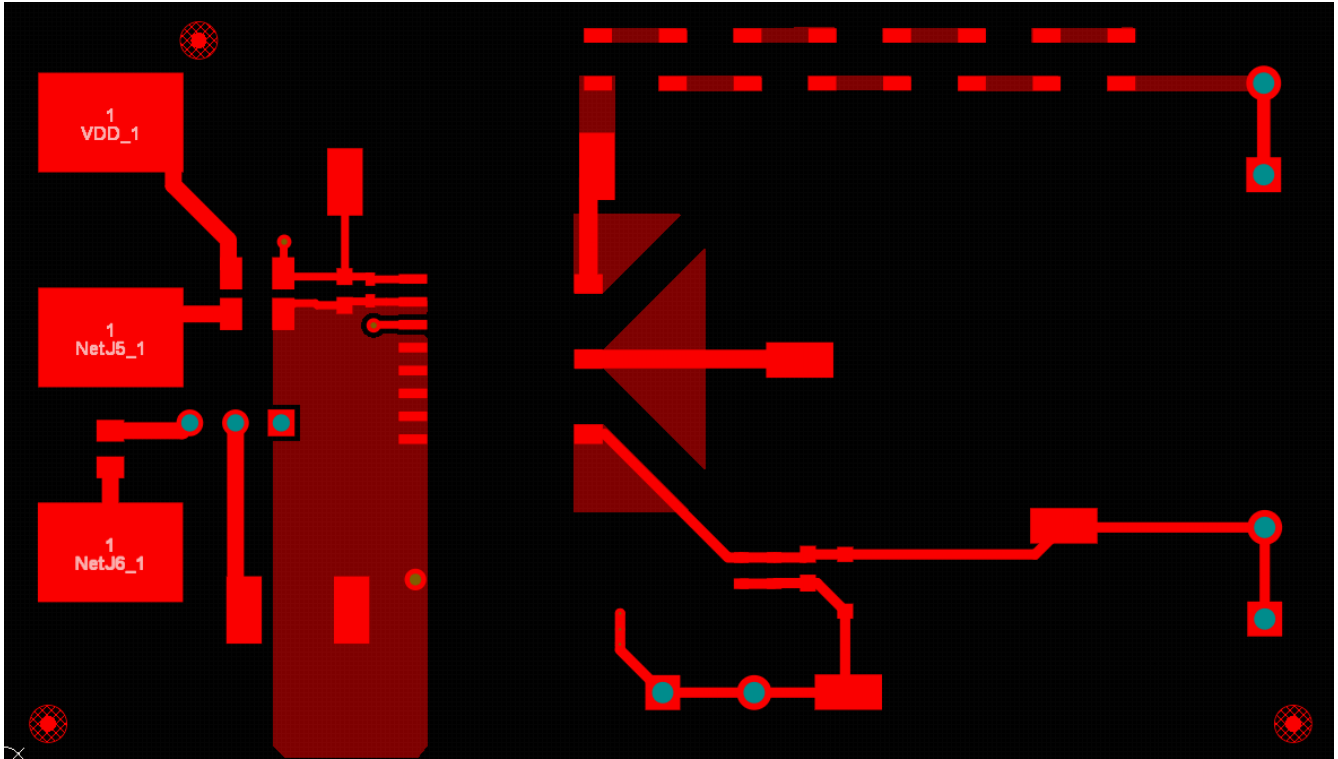

Figure 9-13. TPSI2140-Q1 EVM - Layer 1

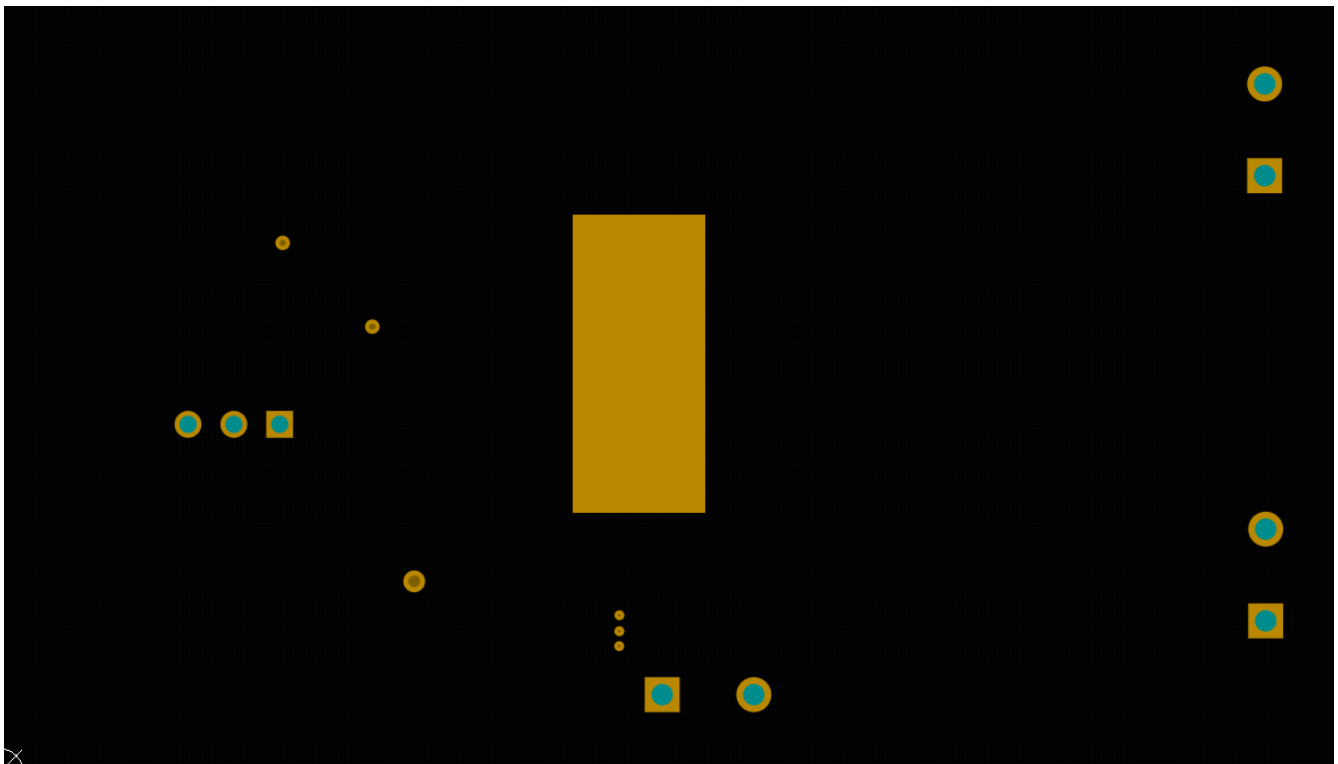

Figure 9-14. TPSI2140-Q1 EVM - Layer 2

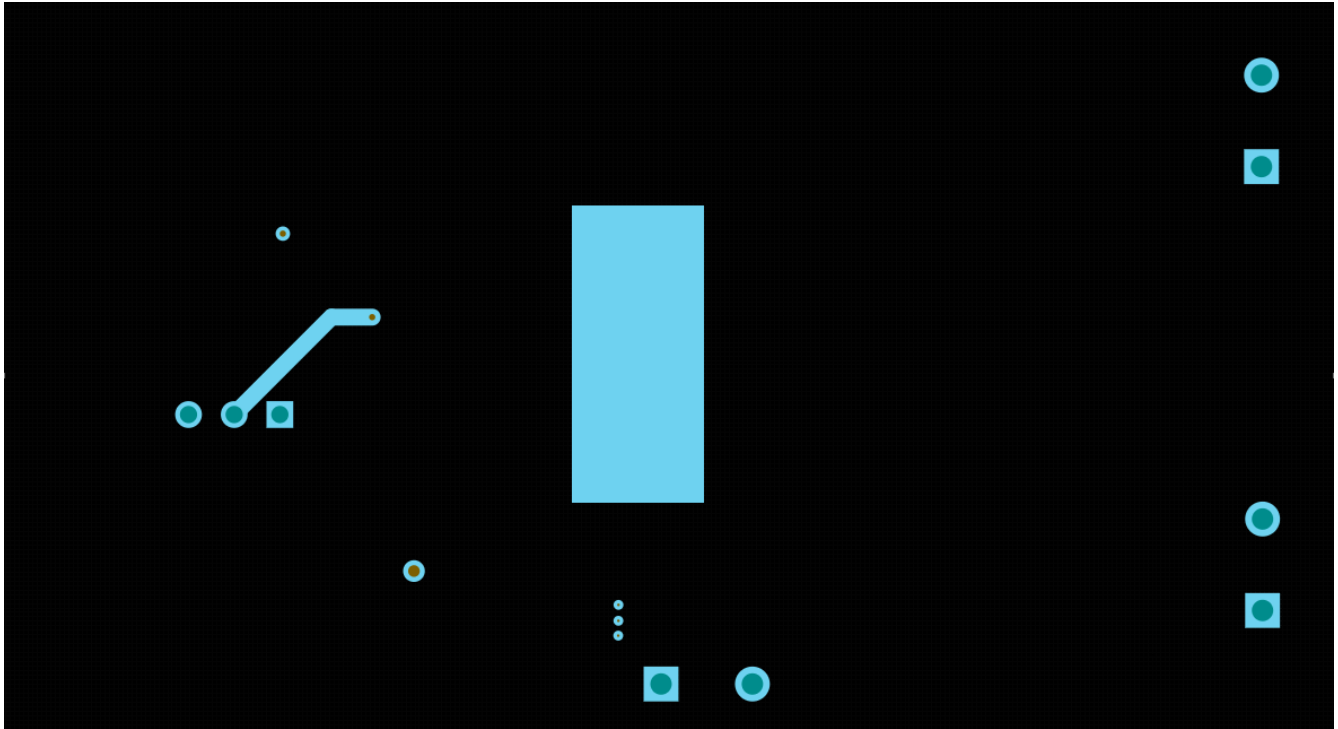

Figure 9-15. TPSI2140-Q1 EVM - Layer 3

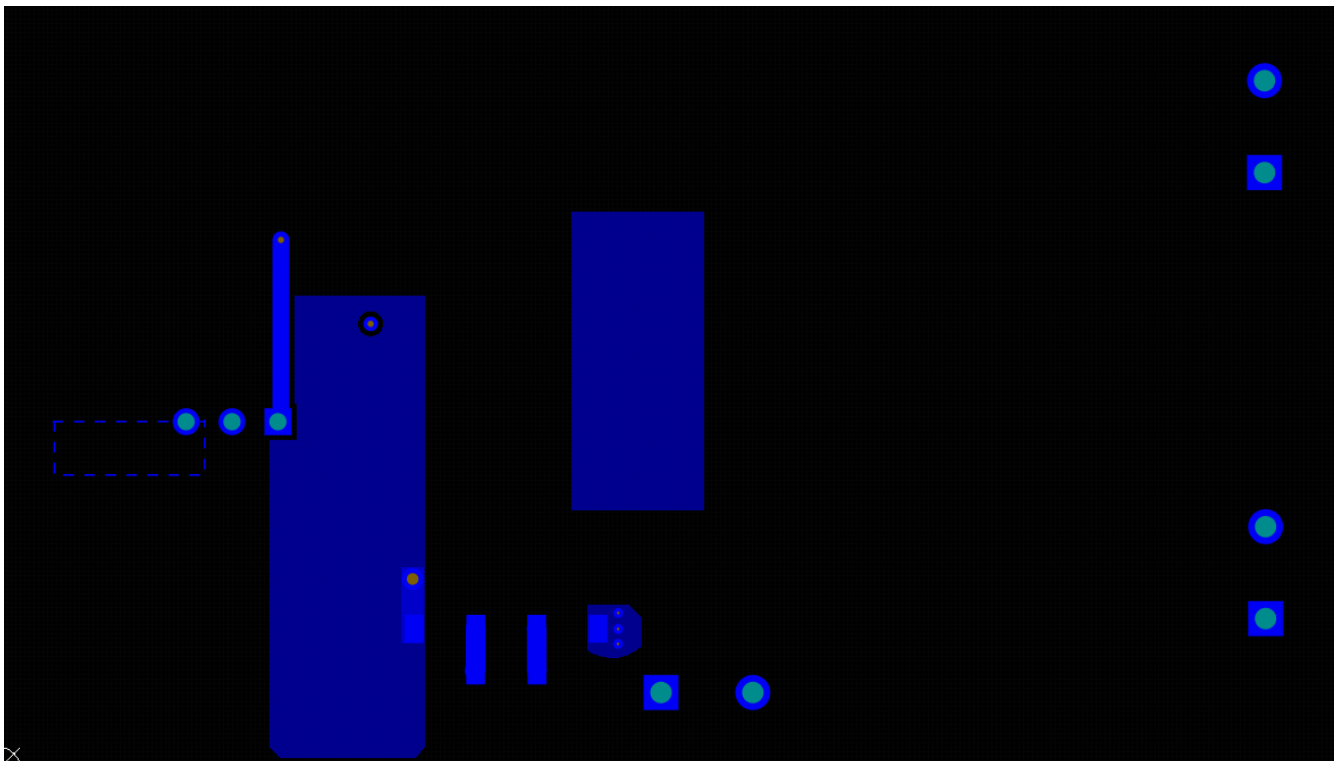

Figure 9-16. TPSI2140-Q1 EVM - Layer 4

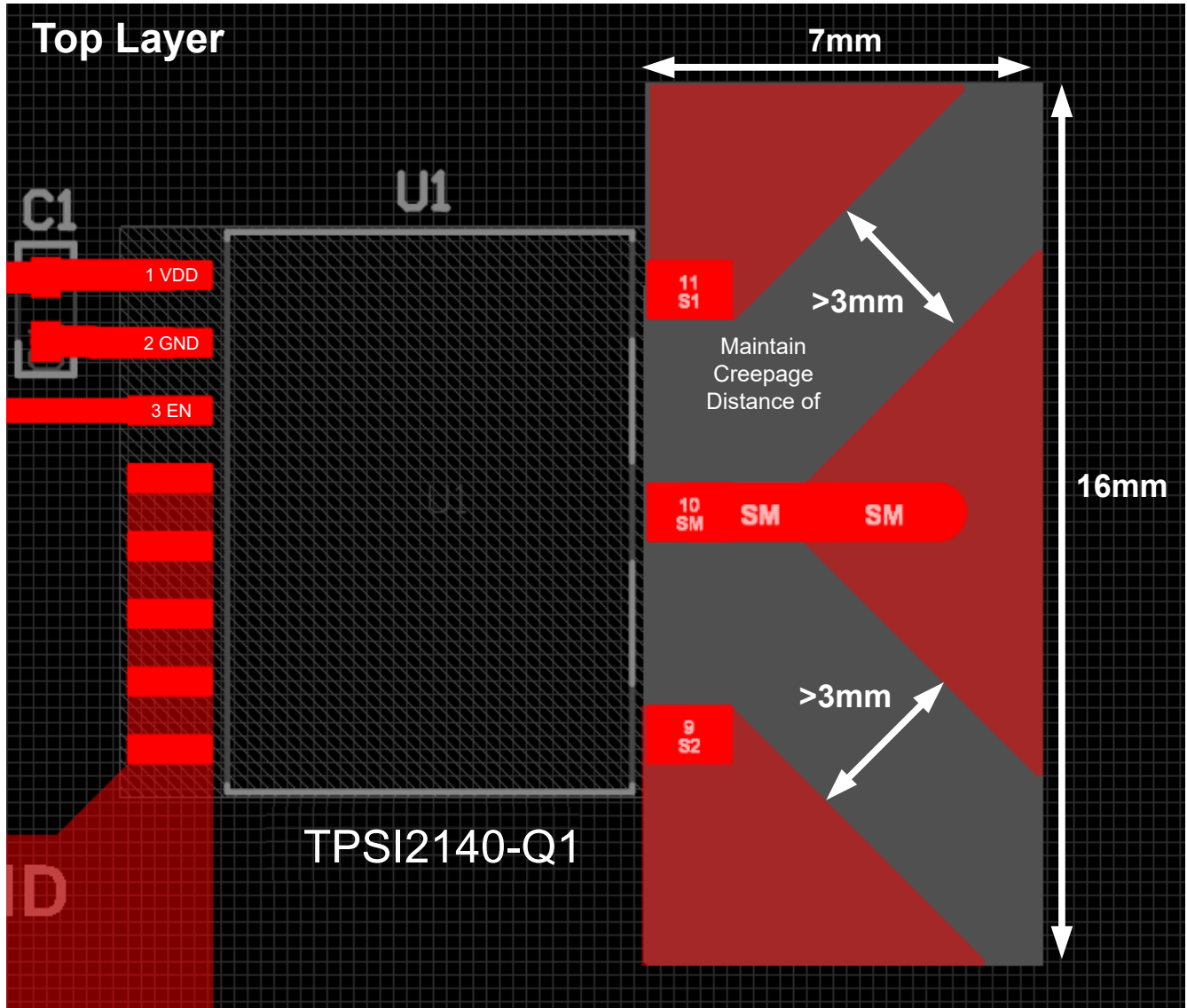

Figure 9-17. TPSI2140-Q1 Secondary Side Layout Recommendation for Optimized Thermal Performance: Top Layer 1

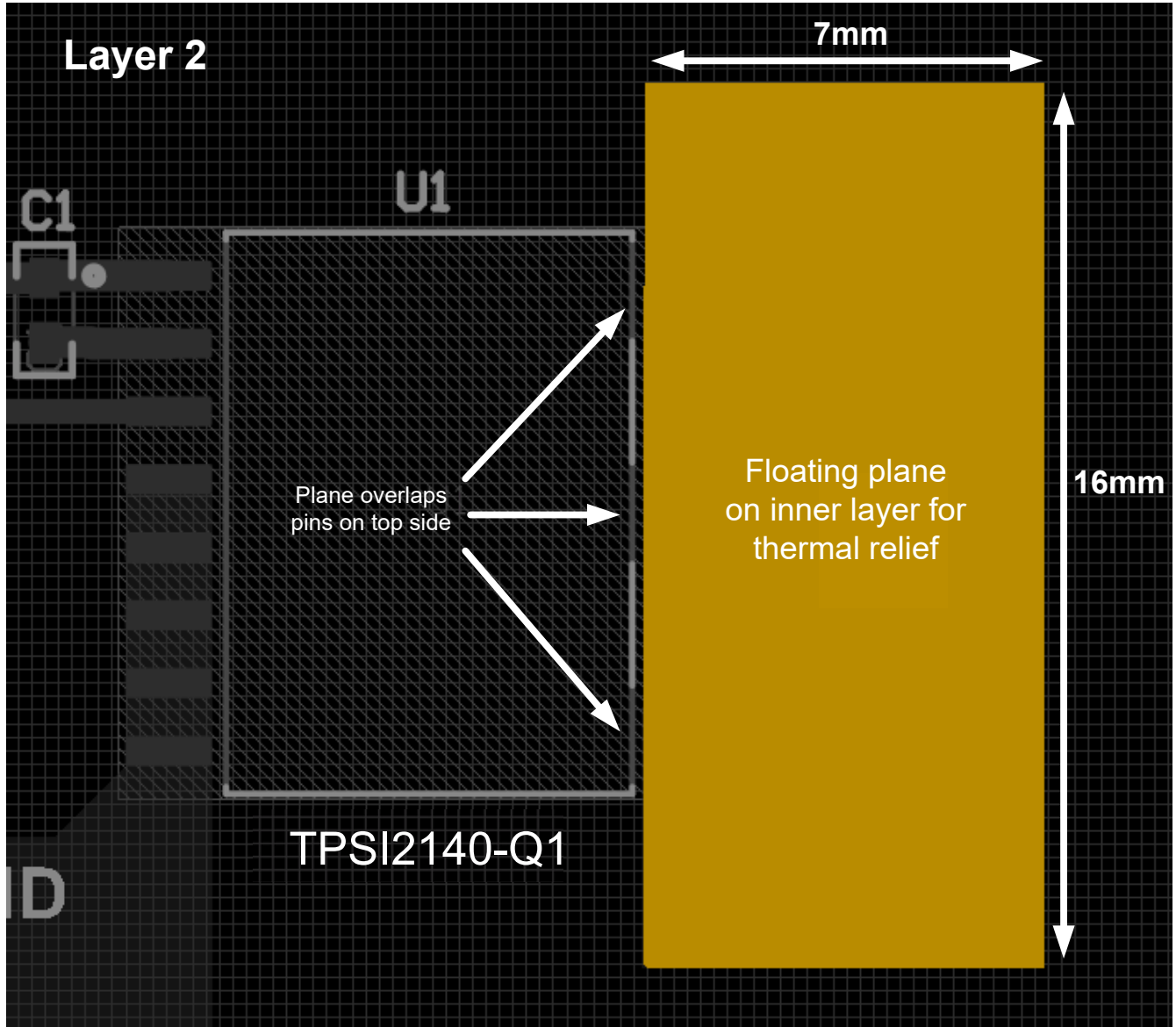

Figure 9-18. TPSI2140-Q1 Secondary Side Layout Recommendation for Optimized Thermal Performance: Inner Layer 2

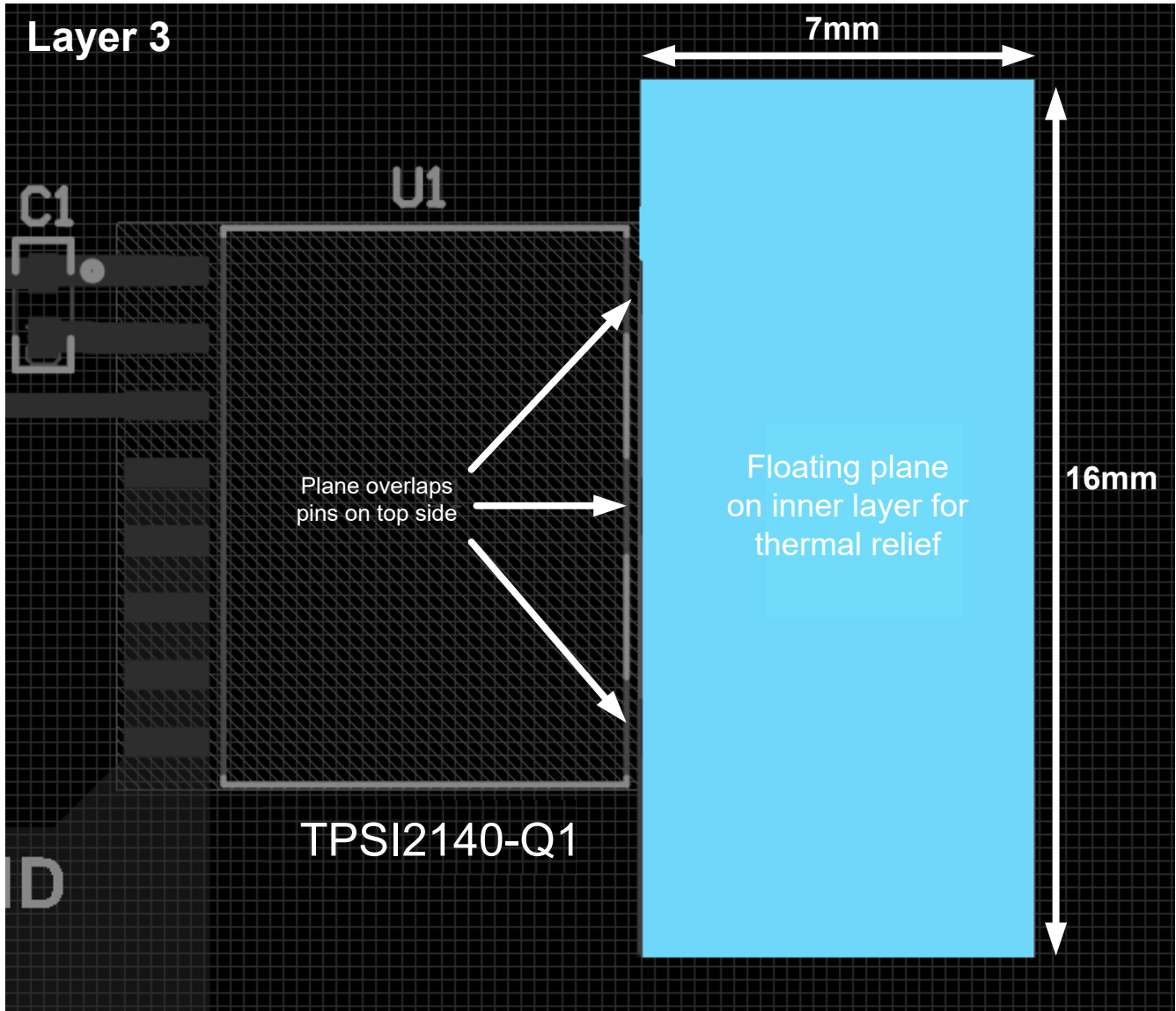
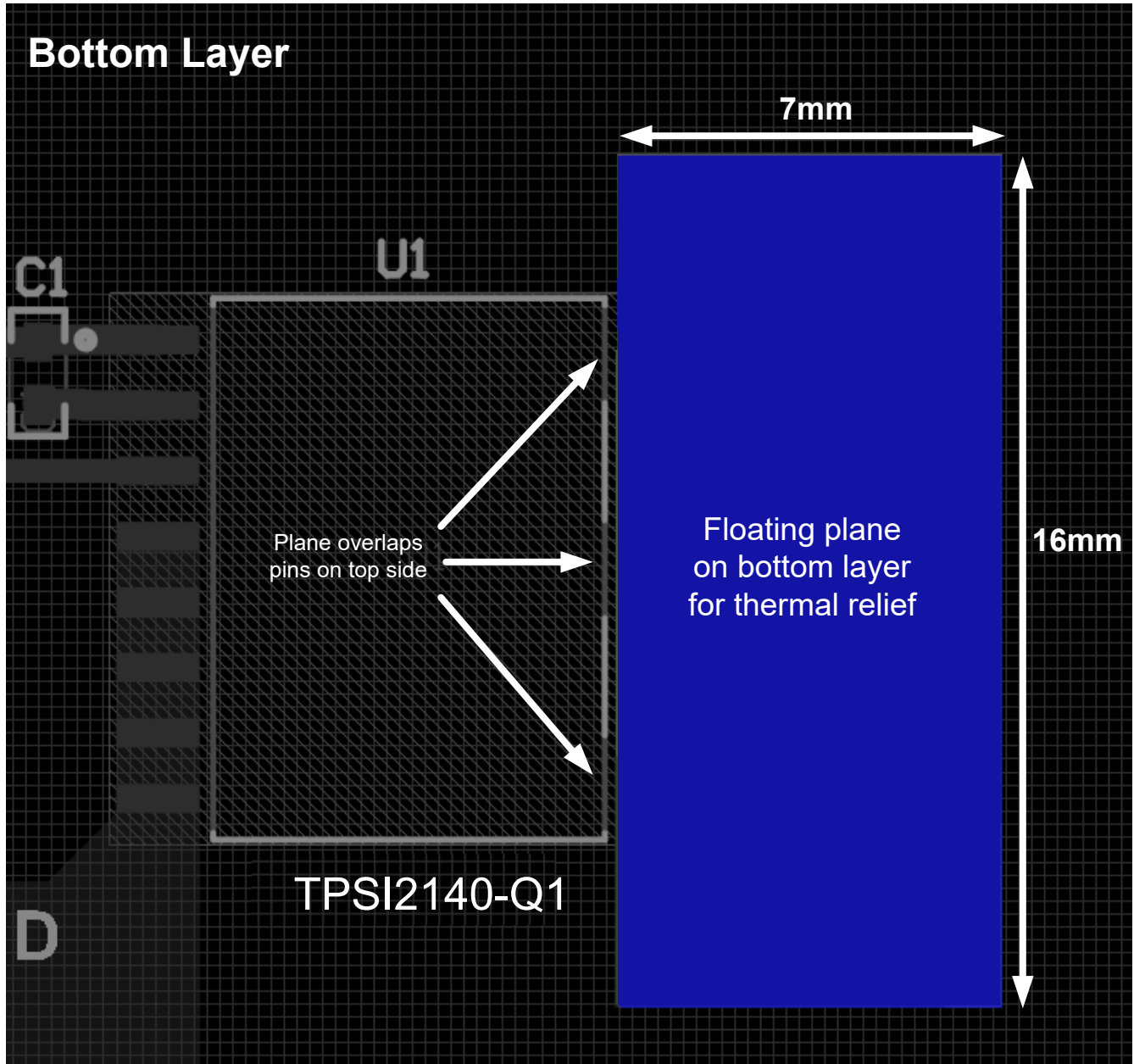

Figure 9-19. TPSI2140-Q1 Secondary Side Layout Recommendation for Optimized Thermal Performance: Inner Layer 3



**Figure 9-20. TPSI2140-Q1 Secondary Side Layout Recommendation for Optimized Thermal Performance: Bottom Layer 4**

#### Interlayer Stitch Capacitance Option for EMI and Thermal Optimization

The layout example below demonstrates an EMI optimized and thermally optimized PCB Design for high voltage switching applications. The overlapping metal layers beneath the TPSI2140-Q1 form an interlayer stitching capacitance between the primary side ground and the S2 pin and increase the board copper content, improving the thermal performance for dielectric withstand testing (HiPot). Using S1 or S2 as the secondary side interlayer stitching capacitance terminal is equally effective. Metal islands on the S1 and S2 pin on the top side and inner layers further improve the thermal performance. Care should be taken to maintain both the vertical and horizontal interlayer dielectric (ILD) spacings between high voltage terminals required by the system.

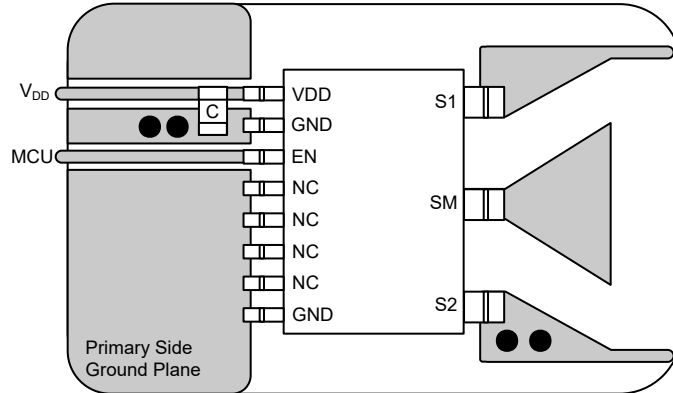

**Figure 9-21. TPSI2140-Q1 Layout with Interlayer Stitch Capacitance: Top Layer (1)**

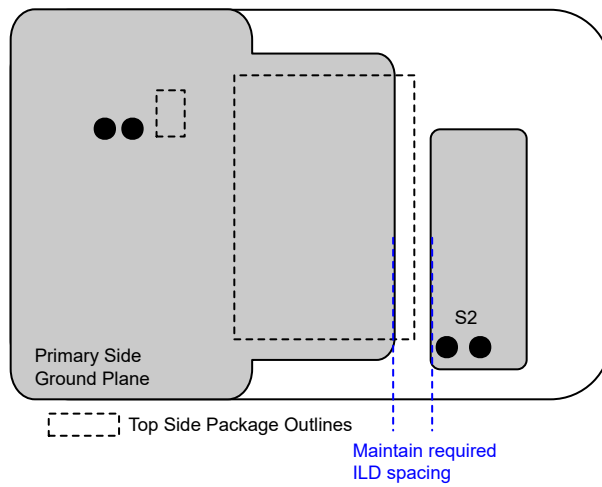

**Figure 9-22. TPSI2140-Q1 Layout with Interlayer Stitch Capacitance: Inner Layer (2,4)**

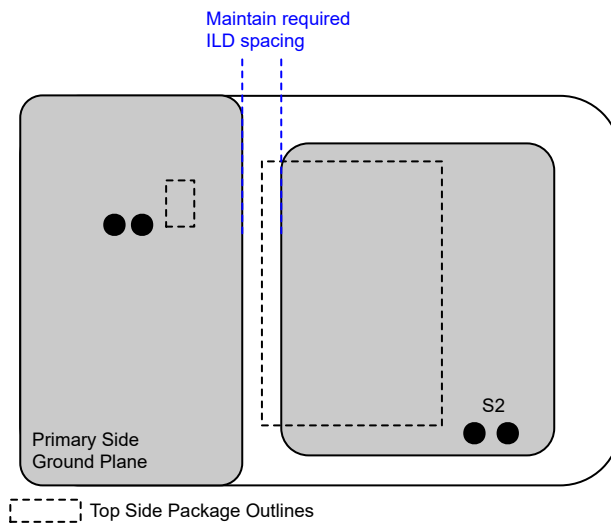

**Figure 9-23. TPSI2140-Q1 Layout with Interlayer Stitch Capacitance: Inner Layer (3)**

## 10 Device and Documentation Support

TI offers an extensive line of development tools. Tools and software to evaluate the performance of the device, generate code, and develop solutions are listed below.

### 10.1 Receiving Notification of Documentation Updates

To receive notification of documentation updates, navigate to the device product folder on [ti.com](https://www.ti.com). Click on *Subscribe to updates* to register and receive a weekly digest of any product information that has changed. For change details, review the revision history included in any revised document.

### 10.2 Support Resources

[TI E2E™ support forums](#) are an engineer's go-to source for fast, verified answers and design help — straight from the experts. Search existing answers or ask your own question to get the quick design help you need.

Linked content is provided "AS IS" by the respective contributors. They do not constitute TI specifications and do not necessarily reflect TI's views; see TI's [Terms of Use](#).

### 10.3 Trademarks

TI E2E™ is a trademark of Texas Instruments.  
All trademarks are the property of their respective owners.

### 10.4 Electrostatic Discharge Caution



This integrated circuit can be damaged by ESD. Texas Instruments recommends that all integrated circuits be handled with appropriate precautions. Failure to observe proper handling and installation procedures can cause damage.

ESD damage can range from subtle performance degradation to complete device failure. Precision integrated circuits may be more susceptible to damage because very small parametric changes could cause the device not to meet its published specifications.

### 10.5 Glossary

[TI Glossary](#) This glossary lists and explains terms, acronyms, and definitions.

## 11 Mechanical, Packaging, and Orderable Information

The following pages include mechanical, packaging, and orderable information. This information is the most current data available for the designated devices. This data is subject to change without notice and revision of this document. For browser-based versions of this data sheet, refer to the left-hand navigation.

**PACKAGING INFORMATION**

Orderable part number	Status (1)	Material type (2)	Package   Pins	Package qty   Carrier	RoHS (3)	Lead finish/ Ball material (4)	MSL rating/ Peak reflow (5)	Op temp (°C)	Part marking (6)
<a href="#">TPSI2140QDWQRQ1</a>	Active	Production	SOIC (DWQ)   11	2000   LARGE T&R	Yes	NIPDAU	Level-3-260C-168 HR	-40 to 125	2140Q

(1) **Status:** For more details on status, see our [product life cycle](#).

(2) **Material type:** When designated, preproduction parts are prototypes/experimental devices, and are not yet approved or released for full production. Testing and final process, including without limitation quality assurance, reliability performance testing, and/or process qualification, may not yet be complete, and this item is subject to further changes or possible discontinuation. If available for ordering, purchases will be subject to an additional waiver at checkout, and are intended for early internal evaluation purposes only. These items are sold without warranties of any kind.

(3) **RoHS values:** Yes, No, RoHS Exempt. See the [TI RoHS Statement](#) for additional information and value definition.

(4) **Lead finish/Ball material:** Parts may have multiple material finish options. Finish options are separated by a vertical ruled line. Lead finish/Ball material values may wrap to two lines if the finish value exceeds the maximum column width.

(5) **MSL rating/Peak reflow:** The moisture sensitivity level ratings and peak solder (reflow) temperatures. In the event that a part has multiple moisture sensitivity ratings, only the lowest level per JEDEC standards is shown. Refer to the shipping label for the actual reflow temperature that will be used to mount the part to the printed circuit board.

(6) **Part marking:** There may be an additional marking, which relates to the logo, the lot trace code information, or the environmental category of the part.

Multiple part markings will be inside parentheses. Only one part marking contained in parentheses and separated by a "-" will appear on a part. If a line is indented then it is a continuation of the previous line and the two combined represent the entire part marking for that device.

**Important Information and Disclaimer:**The information provided on this page represents TI's knowledge and belief as of the date that it is provided. TI bases its knowledge and belief on information provided by third parties, and makes no representation or warranty as to the accuracy of such information. Efforts are underway to better integrate information from third parties. TI has taken and continues to take reasonable steps to provide representative and accurate information but may not have conducted destructive testing or chemical analysis on incoming materials and chemicals. TI and TI suppliers consider certain information to be proprietary, and thus CAS numbers and other limited information may not be available for release.

In no event shall TI's liability arising out of such information exceed the total purchase price of the TI part(s) at issue in this document sold by TI to Customer on an annual basis.

**TAPE AND REEL INFORMATION**

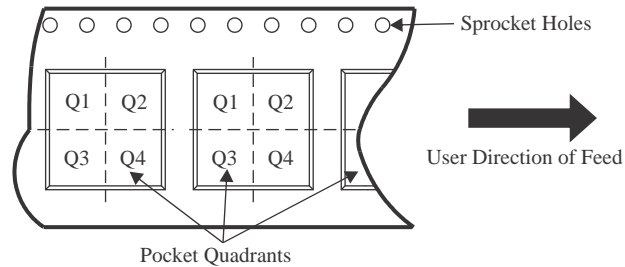
**QUADRANT ASSIGNMENTS FOR PIN 1 ORIENTATION IN TAPE**

\*All dimensions are nominal

Device	Package Type	Package Drawing	Pins	SPQ	Reel Diameter (mm)	Reel Width W1 (mm)	A0 (mm)	B0 (mm)	K0 (mm)	P1 (mm)	W (mm)	Pin1 Quadrant
TPSI2140QDWQRQ1	SOIC	DWQ	11	2000	330.0	16.4	10.75	10.7	2.7	12.0	16.0	Q1

**TAPE AND REEL BOX DIMENSIONS**

\*All dimensions are nominal

Device	Package Type	Package Drawing	Pins	SPQ	Length (mm)	Width (mm)	Height (mm)
TPSI2140QDWQRQ1	SOIC	DWQ	11	2000	350.0	350.0	43.0

# PACKAGE OUTLINE

DWQ0011A

SOIC - 2.65 mm max height

SMALL OUTLINE PACKAGE

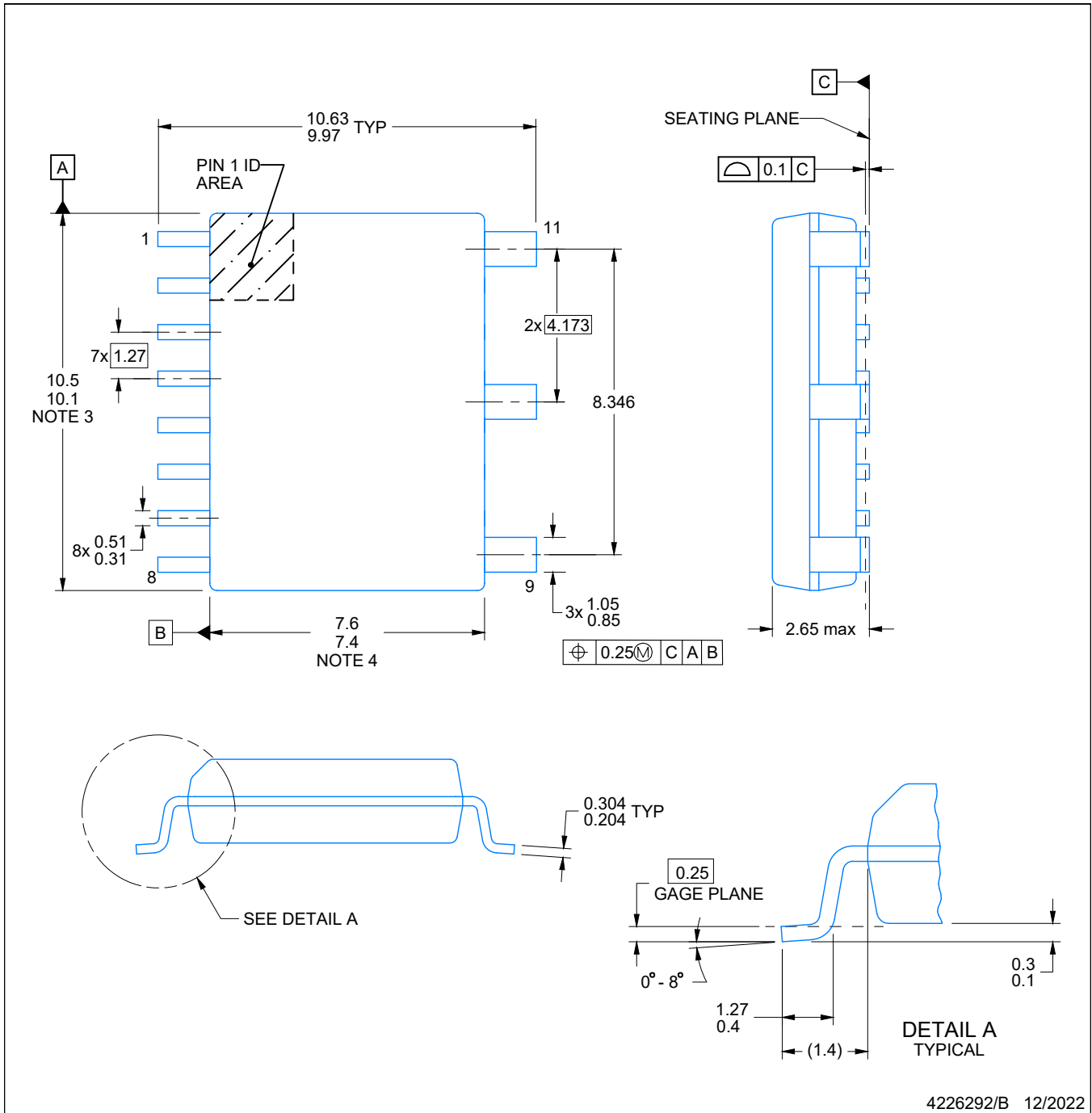

# EXAMPLE BOARD LAYOUT

DWQ0011A

SOIC - 2.65 mm max height

SMALL OUTLINE PACKAGE

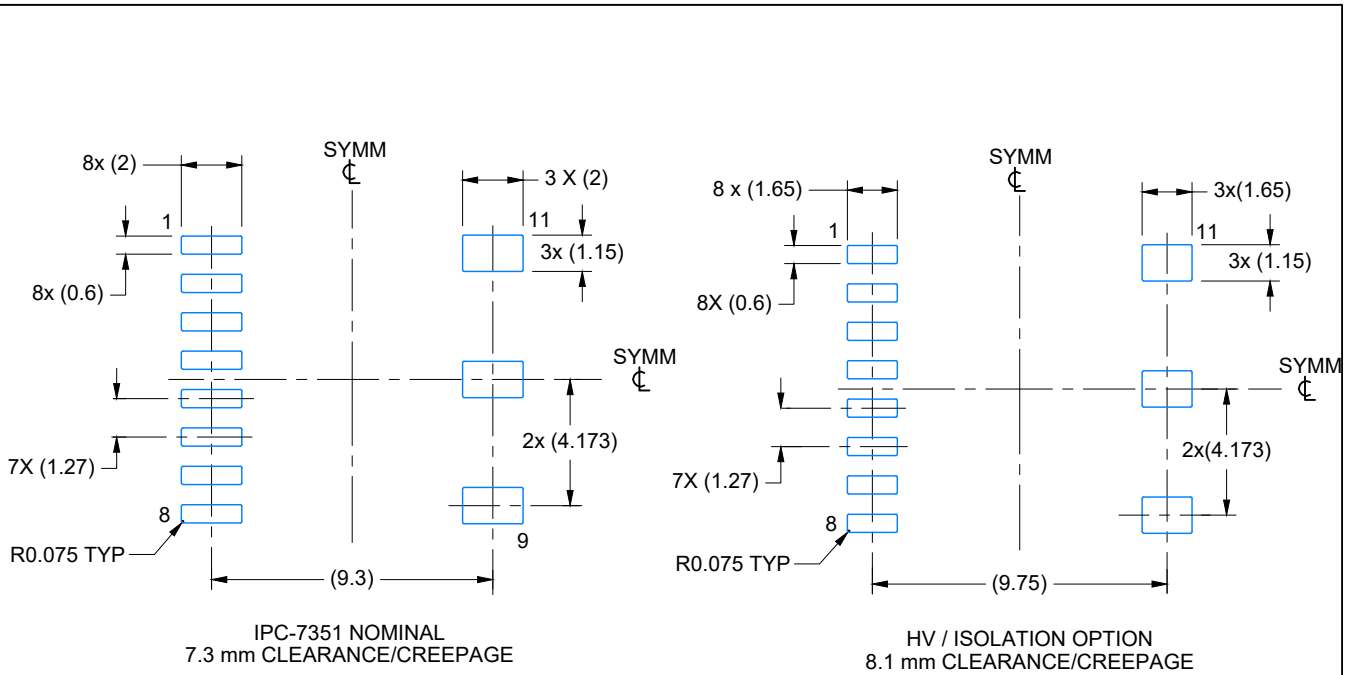

LAND PATTERN EXAMPLE  
SCALE:4X

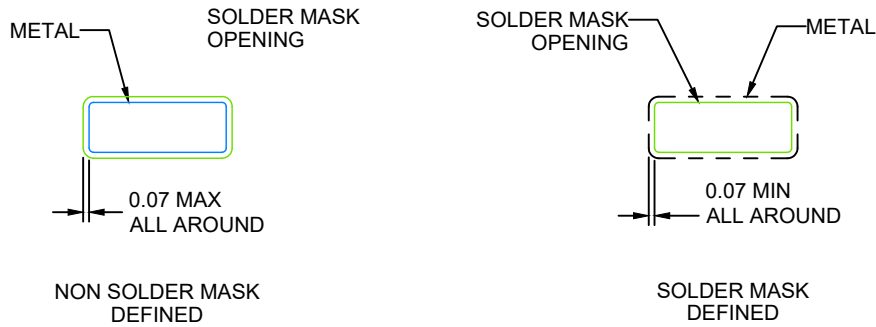

SOLDER MASK DETAILS

4226292/B 12/2022

NOTES: (continued)

- 6. Publication IPC-7351 may have alternate designs.
- 7. Solder mask tolerances between and around signal pads can vary based on board fabrication site.

# EXAMPLE STENCIL DESIGN

DWQ0011A

SOIC - 2.65 mm max height

SMALL OUTLINE PACKAGE

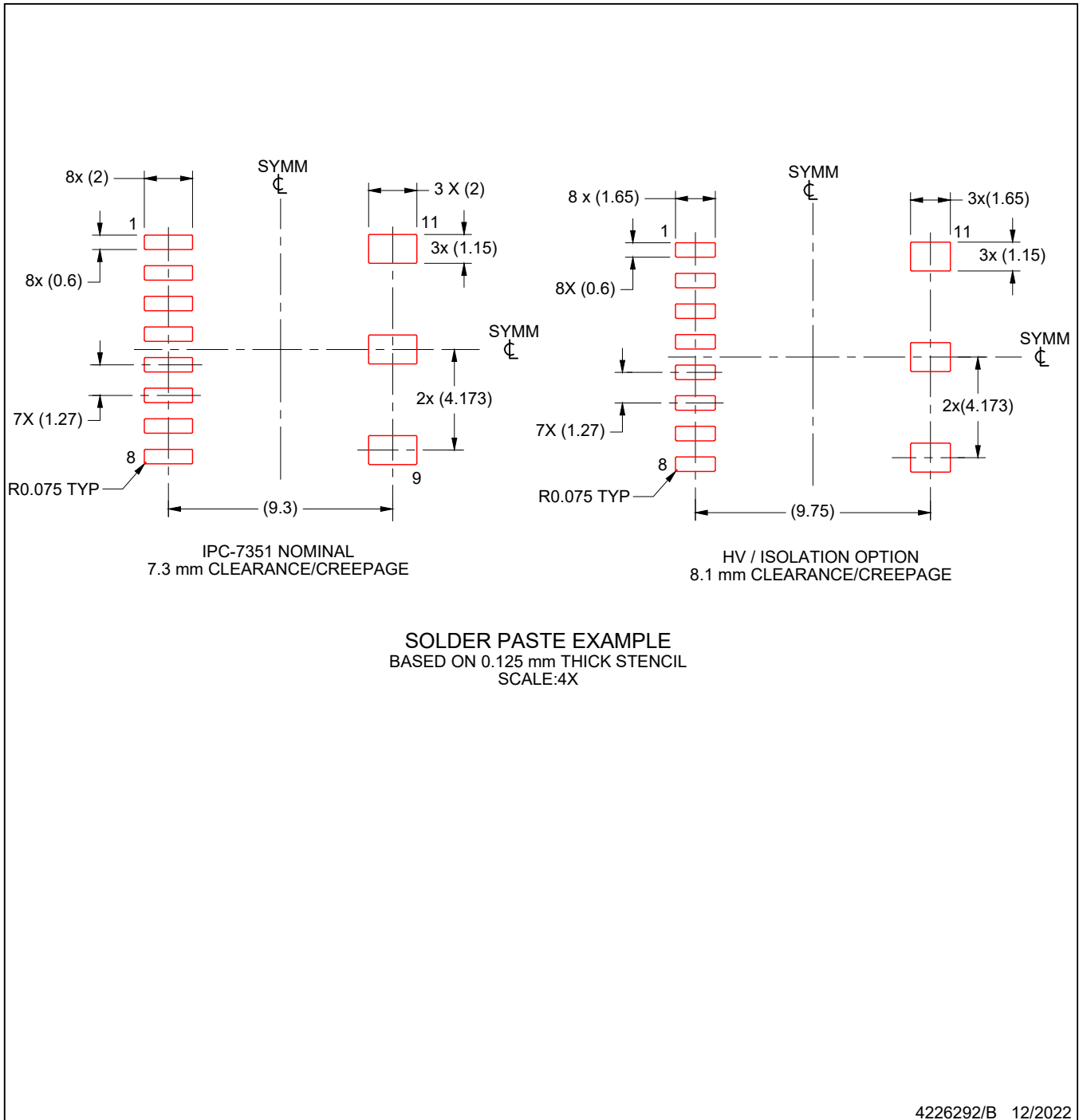

NOTES: (continued)

8. Laser cutting apertures with trapezoidal walls and rounded corners may offer better paste release. IPC-7525 may have alternate design recommendations.
9. Board assembly site may have different recommendations for stencil design.

## IMPORTANT NOTICE AND DISCLAIMER

TI PROVIDES TECHNICAL AND RELIABILITY DATA (INCLUDING DATASHEETS), DESIGN RESOURCES (INCLUDING REFERENCE DESIGNS), APPLICATION OR OTHER DESIGN ADVICE, WEB TOOLS, SAFETY INFORMATION, AND OTHER RESOURCES "AS IS" AND WITH ALL FAULTS, AND DISCLAIMS ALL WARRANTIES, EXPRESS AND IMPLIED, INCLUDING WITHOUT LIMITATION ANY IMPLIED WARRANTIES OF MERCHANTABILITY, FITNESS FOR A PARTICULAR PURPOSE OR NON-INFRINGEMENT OF THIRD PARTY INTELLECTUAL PROPERTY RIGHTS.

These resources are intended for skilled developers designing with TI products. You are solely responsible for (1) selecting the appropriate TI products for your application, (2) designing, validating and testing your application, and (3) ensuring your application meets applicable standards, and any other safety, security, regulatory or other requirements.

These resources are subject to change without notice. TI grants you permission to use these resources only for development of an application that uses the TI products described in the resource. Other reproduction and display of these resources is prohibited. No license is granted to any other TI intellectual property right or to any third party intellectual property right. TI disclaims responsibility for, and you fully indemnify TI and its representatives against any claims, damages, costs, losses, and liabilities arising out of your use of these resources.

TI's products are provided subject to [TI's Terms of Sale](#), [TI's General Quality Guidelines](#), or other applicable terms available either on [ti.com](http://ti.com) or provided in conjunction with such TI products. TI's provision of these resources does not expand or otherwise alter TI's applicable warranties or warranty disclaimers for TI products. Unless TI explicitly designates a product as custom or customer-specified, TI products are standard, catalog, general purpose devices.

TI objects to and rejects any additional or different terms you may propose.

Copyright © 2026, Texas Instruments Incorporated

Last updated 10/2025

## Looking for pricing, stock, or lifecycle information?

Click below to explore more details on WIN SOURCE:

 [View TPS629206QDRLRQ1 on WIN SOURCE](#)

 [Texas Instruments](#) Information

## Optimize Your Supply Chain with WIN SOURCE Solutions

-  Global Sourcing Solution
-  Obsolete Management
-  Cost Control Management
-  Shortage Management
-  Alternative Solution
-  Excess Inventory Management