

DRA821 Jacinto™ Processors

1 Features

Processor cores:

- Dual 64-bit Arm® Cortex®-A72 microprocessor subsystem at up to 2.0 GHz, 24K DMIPS
 - 1MB L2 shared cache per dual-core Cortex®-A72 cluster
 - 32KB L1 DCache and 48KB L1 ICache per A72 core
- 4× Arm® Cortex®-R5F MCUs at up to 1.0 GHz with optional lockstep operation, 8K DMIPS
 - 32K I-Cache, 32K D-Cache, 64K L2 TCM
 - 2× Arm® Cortex®-R5F MCUs in isolated MCU subsystem
 - 2× Arm® Cortex®-R5F MCUs in general compute partition

Memory subsystem:

- 1MB of On-Chip L3 RAM with ECC and coherency
 - ECC error protection
 - Shared coherent cache
 - Supports internal DMA engine
- External Memory Interface (EMIF) module with ECC
 - Supports LPDDR4 memory types that comply with the JESD209-4B specification. (No support for byte mode LPDDR4 memories, or memories with more than 17 row address bits)
 - Supports speeds up to 3200 MT/s
 - 32-bit and 16-bit data bus with inline ECC bus up to 12.8GB/s
- General-Purpose Memory Controller (GPMC)
- 512KB on-chip SRAM in MAIN domain, protected by ECC

Virtualization:

- Hypervisor support in Arm® Cortex®-A72
- Independent processing subsystems with Arm® Cortex®-A72, Arm® Cortex®-R5F with isolated safety MCU island
- IO virtualization support
 - Peripheral Virtualization Unit (PVU) for low latency high bandwidth peripheral traffic
- Multi-region firewall support for memory and peripheral isolation
- Virtualization support with Ethernet, PCIe, and DMA
- **Device security (on select part numbers):**
- Secure boot with secure runtime support
- Customer programmable root key, up to RSA-4K or ECC-512
- Embedded hardware security module

- Crypto hardware accelerators – PKA with ECC, AES, SHA, RNG, DES and 3DES

Functional Safety:

- **Functional Safety-Compliant** targeted (on select part numbers)
 - Developed for functional safety applications
 - Documentation will be available to aid ISO 26262 and IEC 61508 functional safety system design up to ASIL-D/SIL-3 targeted
 - Systematic capability up to ASIL-D/SIL-3 targeted
 - Hardware integrity up to ASIL-D/SIL-3 targeted for MCU Domain
 - Hardware integrity up to ASIL-D/SIL-3 targeted for Extended MCU (EMCU) portion of the Main Domain
 - Hardware integrity up to ASIL-B/SIL-2 targeted for remainder of the Main Domain
 - FFI isolation provided between EMCU and the remainder of the Main Domain
 - Safety-related certification
 - ISO 26262 and IEC 61508 planned
- AEC-Q100 qualified on part number variants ending in Q1
- **High-speed interfaces:**
 - Integrated Ethernet TSN/AVB switch supporting up to 4 (DRA821U4) or 2 (DRA821U2) external ports:
 - One port supports 5Gb, 10Gb USXGMII/XFI
 - All ports support 2.5Gb SGMII
 - All ports support 1Gb SGMII/RGMII
 - DRA821U4: Any single port can support QSGMII (using all 4 internal ports)
 - Non-blocking wire-rate store and forward switch
 - InterVLAN (Layer3) routing support
 - Time synchronization support with IEEE 1588(annex D,E,F)
 - TSN/AVB support for traffic scheduling, shaping
 - Port mirroring feature for debug and diagnostics
 - Policing and rate limiting support
 - One RGMII/RMII port in safety MCU island
- One PCI-Express® Gen3 controller
 - Gen1, Gen2, and Gen3 operation with auto-negotiation
 - 4× lanes
- One USB 3.1 Gen1 dual-role device subsystem
 - Supports type-C switching



- Independently configurable as USB host, USB peripheral, or USB dual-role device

Automotive interfaces:

- Twenty CAN-FD ports
- 12× Universal Asynchronous Receiver/Transmitter (UART)
- 11× Serial Peripheral Interfaces (SPI)
- One 8-channel ADC
- 10× Inter-Integrated Circuit (I2C™)
- 2× Improved Inter-Integrated Circuit (I3C®)

Audio interfaces:

- 3× Multichannel Audio Serial Port (McASP) modules

Flash memory interfaces:

- Embedded Multi Media Card (eMMC™ 5.1) interface
 - Support speeds of up to HS400

- One Secure Digital® 3.0/Secure Digital Input Output 3.0 (SD3.0/SDIO3.0) interfaces
- One Octal SPI / Xccela™ / HyperBus™ Memory Controller (HBMC) interface
- 16-nm FinFET technology
- 17.2 mm x 17.2 mm, 0.8 mm pitch, IPC Class 3 PCB

2 Applications

- [Automotive gateway](#)
- [Vehicle compute](#)
- [Body control module](#)
- [Telematics control unit](#)
- [V2X/V2V](#)
- [Factory automation gateways](#)
- [Communications equipment](#)
- [Industrial transport](#)
- [Building Automation Gateway](#)

3 Description

Jacinto™ DRA821x processors, based on the Armv8 64-bit architecture, are optimized for gateway systems with cloud connectivity. The System-on-Chip (SoC) design reduces system-level costs and complexity through integration—notably, a system MCU, functional safety and security features, and an Ethernet switch for high-speed communication. Integrated diagnostics and functional safety features are targeted to ASIL-D and SIL 3 certification requirements. Real-time control and low-latency communication are enabled by a PCIe controller and a TSN capable Gigabit Ethernet switch.

Up to four general-purpose Arm® Cortex®-R5F subsystems can handle low-level, timing-critical processing tasks and leave the Arm® Cortex®-A72 core unencumbered for advanced and cloud-based applications.

Jacinto DRA821x processors also include the concept of the Extended MCU (eMCU) domain. This domain is a subset of the processors and peripherals on the main domain targeted at higher functional safety enablement, such as ASIL-D/SIL-3. The functional block diagram highlights which IP are included in the eMCU. For more details about eMCU and functional safety, see the ***DRA821 Safety Manual Processors Texas Instruments Jacinto™ 7 Family of Products (SPRUIX4)***.

Package Information

PART NUMBER	PACKAGE ⁽¹⁾	PACKAGE SIZE ⁽²⁾
DRA821U4-Q1 DRA821U4	ALM (FCBGA, 433)	17.2 mm × 17.2 mm
DRA821U2-Q1 DRA821U2	ALM (FCBGA, 433)	17.2 mm × 17.2 mm
XJ7200GB	ALM (FCBGA, 433)	17.2 mm × 17.2 mm

(1) For more information, see [Mechanical, Packaging, and Orderable Information](#).

(2) The package size (length × width) is a nominal value and includes pins, where applicable.

3.1 Functional Block Diagram

Figure 3-1 is functional block diagram for the device.

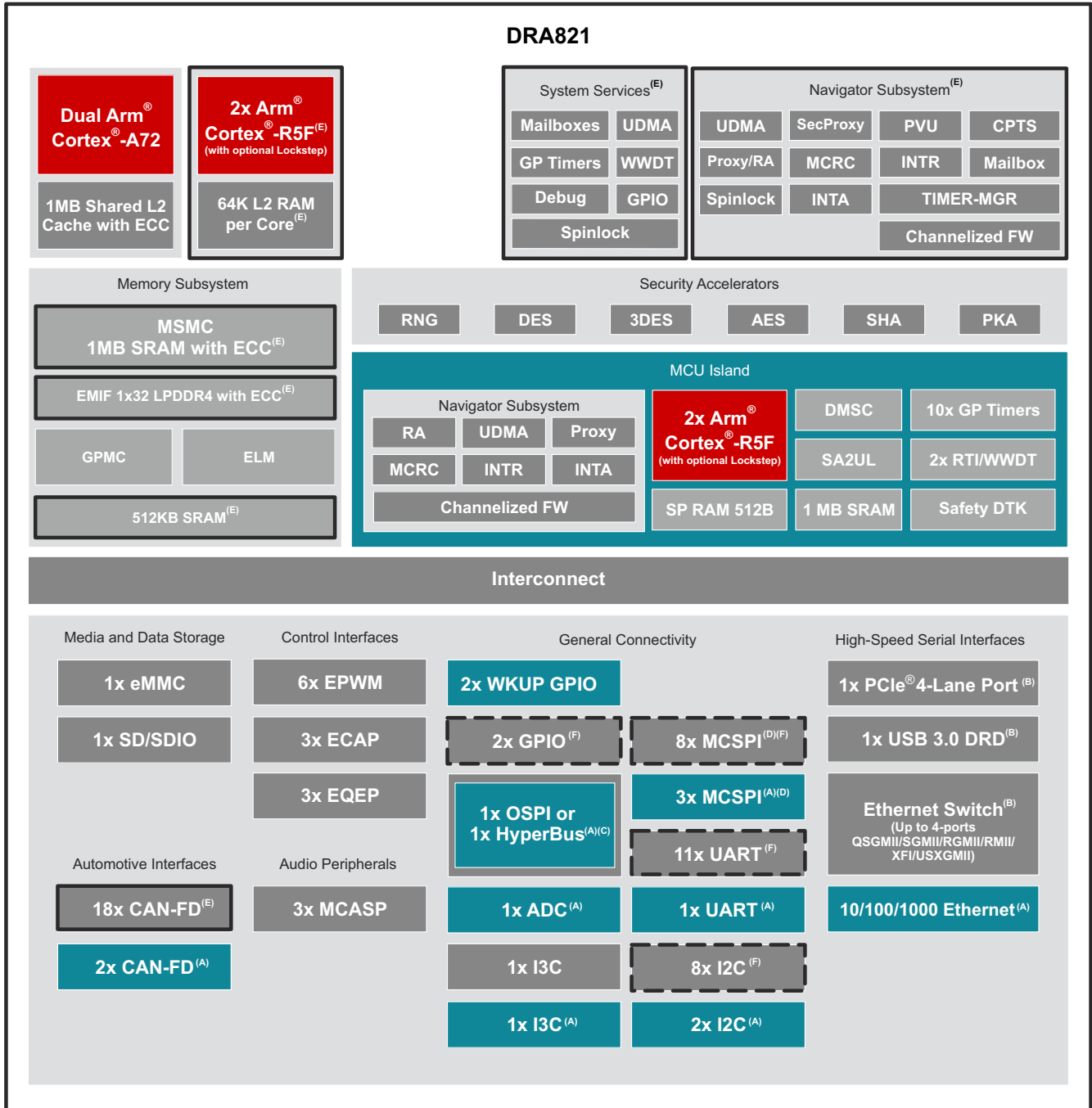

- A. Both WKUP and MCU domain instances are located on the MCU island but available for the full system to access.
- B. SGMII, USB3.0, and PCIE share total of four SerDes lanes. A maximum of two of the three IP (for example, SGMII and USB) can be used concurrently.
- C. Flash interface can be configured as OSPI0, or HyperBus.
- D. One port is internally connected only. Not connected to any pins.
- E. A solid black box indicates the IP is part of the Extended MCU (eMCU).
- F. A dashed black box indicates that some instances of the IP are present in the eMCU and some instances are present in the non-eMCU portion of the Main Domain.

Figure 3-1. Functional Block Diagram

Table of Contents

1 Features	1	7.8 Thermal Resistance Characteristics.....	106
2 Applications	2	7.9 Timing and Switching Characteristics.....	107
3 Description	2	8 Detailed Description	219
3.1 Functional Block Diagram.....	2	8.1 Overview.....	219
4 Revision History	5	8.2 Processor Subsystems.....	220
5 Device Comparison	6	8.3 Other Subsystems.....	220
5.1 Related Products.....	7	9 Applications, Implementation, and Layout	227
6 Terminal Configuration and Functions	8	9.1 Power Supply Mapping.....	227
6.1 Pin Diagram.....	8	9.2 Device Connection and Layout Fundamentals.....	231
6.2 Pin Attributes.....	9	9.3 Peripheral- and Interface-Specific Design Information.....	231
6.3 Signal Descriptions.....	46	10 Device and Documentation Support	238
6.4 Pin Multiplexing.....	80	10.1 Device Nomenclature.....	238
6.5 Connections for Unused Pins.....	89	10.2 Tools and Software.....	242
7 Specifications	92	10.3 Documentation Support.....	243
7.1 Absolute Maximum Ratings.....	92	10.4 Support Resources.....	243
7.2 ESD Ratings.....	94	10.5 Trademarks.....	243
7.3 Recommended Operating Conditions.....	94	10.6 Electrostatic Discharge Caution.....	243
7.4 Power-On-Hours (POH).....	96	10.7 Glossary.....	243
7.5 Operating Performance Points.....	97	11 Mechanical, Packaging, and Orderable Information	244
7.6 Electrical Characteristics.....	98	11.1 Packaging Information.....	244
7.7 VPP Specifications for One-Time Programmable (OTP) eFuses.....	105		

4 Revision History

Changes from December 17, 2022 to June 30, 2023 (from Revision D (December 2022) to Revision E (June 2023))

	Page
• (Package Information): Updated/Changed table to match the new content standard.....	2
• (Device Comparison): Updated/Changed the "DRA821U2 CPSW5G supports ..." footnote clarifying options/restrictions.....	6
• (MAIN Domain/ MMC0 Signal Descriptions): Deleted the external pull-up resistor connection requirements footnote on the MMC command and data signals for MMC0.....	70
• (Recommended Operating Conditions): Added clarification to the "... supply inputs" footnote, specifically for VDD_CORE, VDD_MCU, and VDD_CPU domains plus, added cross-references to the MIN/MAX values....	94
• (Operating Performance Points): Added "Supported OPP vs Max Frequency" table to include "OPP_LOW" and "OPP_NOM" plus footnote cross-references.....	97
• (MMCS1 Timing Conditions): Deleted the SR ₁ , Input slew rate specification for UHS-I DDR50 mode.....	202

5 Device Comparison

Table 5-1 shows the features of the SoC, highlighting the differences.

Table 5-1. Device Comparison

Same table as the unhidden one. Done to remove columns A4 and A2

FEATURES	REFERENCE NAME	DRA821U4	DRA821U2
Features			
PROCESSORS AND ACCELERATORS			
Speed Grades (see Table 7-1)		T, L, E	E, C
Arm Cortex-A72 Microprocessor Subsystem	Arm A72	Dual Core	Dual Core
Arm Cortex-R5F	Arm R5F	Quad Core	Quad Core
	Lockstep	Optional ⁽⁵⁾	Optional ⁽⁵⁾
Device Management Security Controller	DMSC	Yes	Yes
Security Accelerators	SA	Yes	Yes
SAFETY AND SECURITY			
Safety Targeted	Safety	Optional ⁽⁵⁾	Optional ⁽⁵⁾
Device Security	Security	Optional ⁽⁶⁾	Optional ⁽⁶⁾
AEC-Q100 Qualified	Q1	Optional ⁽⁷⁾	Optional ⁽⁷⁾
PROGRAM AND DATA STORAGE			
On-Chip Shared Memory (RAM) in MAIN Domain	OCSRAM	512KB SRAM	512KB SRAM
On-Chip Shared Memory (RAM) in MCU Domain	MCU_MSRAM	1MB SRAM	1MB SRAM
Multicore Shared Memory Controller	MSMC	1MB (On-Chip SRAM with ECC)	1MB (On-Chip SRAM with ECC)
LPDDR4 DDR Subsystem	DDRSS	Up to 8GB (16/32-bit data) with inline ECC	Up to 8GB (16/32-bit data) with inline ECC
	SECEDED	7-bit	7-bit
General-Purpose Memory Controller	GPMC	Up to 1GB with ECC	Up to 1GB with ECC
PERIPHERALS			
Modular Controller Area Network Interface with Full CAN-FD Support	MCAN	20	20
Navigator Subsystem	NAVSS	2	2
General-Purpose I/O	GPIO	Up to 141	Up to 141
Inter-Integrated Circuit Interface	I2C	10	10
Improved Inter-Integrated Circuit Interface	I3C	2	2
Analog-to-Digital Converter	ADC	1	1
Multichannel Serial Peripheral Interface	MCSPi	11 ⁽⁸⁾	11 ⁽⁸⁾
Multichannel Audio Serial Port	MCASP0	16 Serializers	16 Serializers
	MCASP1	12 Serializers	12 Serializers
	MCASP2	6 Serializers	6 Serializers
MultiMedia Card/ Secure Digital Interface	MMCSd0	eMMC (8-bits)	eMMC (8-bits)
	MMCSd1	SD/SDIO (4-bits)	SD/SDIO (4-bits)
Flash Subsystem (FSS)	OSPI	8-bits ⁽⁴⁾	8-bits ⁽⁴⁾
	HyperBus	Yes ⁽⁴⁾	Yes ⁽⁴⁾
PCI Express Port with Integrated PHY	PCIE	Up to Four Lanes ⁽¹⁾	Up to Four Lanes ⁽¹⁾
Ethernet Interface	CPSW2G	1 Port ⁽³⁾	1 Port ⁽³⁾
	CPSW5G	4 Ports ⁽¹⁾ ⁽²⁾	2 Ports ⁽¹⁾ ⁽²⁾
General-Purpose Timers	TIMER	30	30
Enhanced Pulse-Width Modulator Module	EPWM	6	6

Table 5-1. Device Comparison (continued)

Same table as the unhidden one. Done to remove columns A4 and A2

FEATURES	REFERENCE NAME	DRA821U4	DRA821U2
Enhanced Capture Module	ECAP	3	3
Enhanced Quadrature Encoder Pulse Module	EQEP	3	3
Universal Asynchronous Receiver and Transmitter	UART	12	12
Universal Serial Bus (USB3.1) SuperSpeed Dual-Role-Device (DRD) Ports with SS PHY	USB	Yes ⁽¹⁾	Yes ⁽¹⁾

- (1) SGMII, USB3.0, and PCIE share total of four SerDes lanes.
- (2) DRA821U4 CPSW5G supports the following instances, signals, and modes of operation:
 - PORT1 **Signals:** RMII1/RGMII1/SGMII1, **Modes:** One of 5Gb, 10Gb USXGMII/XFI, 2.5 Gb SGMII/XAUI, 1Gb SGMII, 1Gb RGMII, 100Mb RMII, 5Gb QSGMII
 - PORT2 **Signals:** RMII2/RGMII2/SGMII2, **Modes:** One of 2.5 Gb SGMII/XAUI, 1Gb SGMII, 1Gb RGMII, 100Mb RMII, 5Gb QSGMII
 - PORT3 **Signals:** RMII3/RGMII3/SGMII3, **Modes:** One of 2.5 Gb SGMII/XAUI, 1Gb SGMII, 1Gb RGMII, 100Mb RMII, 5Gb QSGMII
 - PORT4 **Signals:** RMII4/RGMII4/SGMII4, **Modes:** One of 2.5 Gb SGMII/XAUI, 1Gb SGMII, 1Gb RGMII, 100Mb RMII, 5Gb QSGMII
 - QSGMII mode combines all four internal ports of the CPSW onto a single SERDES lane. Each port in this mode operates at 1-Gb full duplex
 - Any one of the port signals SGMII1:4 can be selected for this SERDES connectivity where upon the non-selected signals are unused by the CPSW

DRA821U2 CPSW5G supports a maximum of TWO RMII_n/RGMII_n/SGMII_n ports to be used in a system. A system design can choose any TWO of the available ports between PORT1, PORT2, PORT3, or PORT4. QSGMII is not supported since QSGMII combines all four internal ports of the CPSW onto a single SERDES lane.

- (3) CPSW2G supports the following instances, signals, and modes of operation:
 - PORT1 **Signals:** MCU_RMII1/MCU_RGMII1, **Modes:** One of 1Gb RGMII, 100Mb RMII
- (4) Flash interface can be configured as OSPI0, or HyperBus.
- (5) Safety features including R5F Lockstep and SIL/ASIL ratings are only applicable to select part number variants as indicated by the Device Type (Y) identifier in the [Section 10.1.2, Nomenclature Description Table](#).
- (6) Device security features including Secure Boot and Customer Programmable Keys are applicable to select part number variants as indicated by the Device Type (Y) identifier in the [Section 10.1.2, Nomenclature Description table](#).
- (7) AEC-Q100 qualification is applicable to select part number variants as indicated by the Automotive Designator (Q1) identifier in the [Section 10.1.2, Nomenclature Description table](#).
- (8) Two ports are internally connected only. Not connected to any pins.

5.1 Related Products

Companion Products for DRA821U Review products that are frequently purchased or used in conjunction with this product.

Software Development Kit for DRA821 Jacinto™ Processors Processor SDK RTOS (PSDK RTOS) can be used together with Processor SDK Linux (PSDK Linux) or Processor SDK QNX (PSDK QNX), to form a multi-processor software development platform for DRA821 SoCs within the TI's Jacinto™ Processors platform. The SDK provides a comprehensive set of software tools and components to help users develop and deploy their applications on supported J7 SoCs. PSDK RTOS and either PSDK Linux or PSDK QNX can be used together to implement various use-cases in factory and building automation, and gateway systems.

DRA821 Evaluation Module The J700XSOMXEVM paired with the [J721EXCP01EVM Common Processor Board](#) is an evaluation platform designed to speed up development efforts and reduce time to market for networking applications throughout automotive and industrial markets.

The EVM is supported by Processor SDK, which includes foundational drivers, compute and vision kernels, and example application frameworks and demonstrations that show you how to take advantage of the powerful, heterogeneous architecture of Jacinto 7 processors.

Application Notes and White Paper Gateway application processor with integrated system MCU.

6 Terminal Configuration and Functions

6.1 Pin Diagram

Note

The terms "ball", "pin", and "terminal" are used interchangeably throughout the document. An attempt is made to use "ball" only when referring to the physical package.

Figure 6-1 shows the ball locations for the 433-ball flip chip ball grid array (FCBGA) package that are used in conjunction with Table 6-1 through Table 6-107 to locate signal names and ball grid numbers.

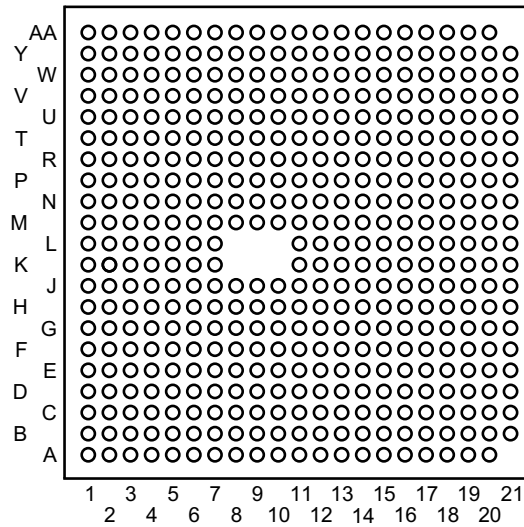

Figure 6-1. ALM FCBGA-N433 Pin Diagram (Bottom View)

6.2 Pin Attributes

Table 6-1. Pin Attributes

BALL NUMBER [1]	BALL NAME [2]	SIGNAL NAME [3]	MUX MODE [4]	TYPE [5]	BALL RESET STATE [6]	BALL RESET REL. MUX MODE [7]	I/O VOLTAGE VALUE [8]	POWER [9]	HYS [10]	BUFFER TYPE [11]	PULL UP/DOWN TYPE [12]	DSIS [13]	RX ACTIVE/ TX DISABLE [14]	IO RET [15]
M7	CAP_VDDS0	CAP_VDDS0		PWR										
G14	CAP_VDDS0_MCU	CAP_VDDS0_MCU		PWR										
F9	CAP_VDDS1_MCU	CAP_VDDS1_MCU		PWR										
T12	CAP_VDDS2	CAP_VDDS2		PWR										
F10	CAP_VDDS2_MCU	CAP_VDDS2_MCU		PWR										
L15	CAP_VDDS5	CAP_VDDS5		PWR										
H1	DDR0_CKN	DDR0_CKN		IO			1.1 V	VDDS_DDR, VDDS_DDR_C, VDDS_DDR_BIAS		DDR				
G1	DDR0_CKP	DDR0_CKP		IO			1.1 V	VDDS_DDR, VDDS_DDR_C, VDDS_DDR_BIAS		DDR				
J5	DDR0_RESETh	DDR0_RESETh		IO			1.1 V	VDDS_DDR, VDDS_DDR_C, VDDS_DDR_BIAS		DDR				
G4	DDR0_CA0	DDR0_CA0		IO			1.1 V	VDDS_DDR, VDDS_DDR_C, VDDS_DDR_BIAS		DDR				
H3	DDR0_CA1	DDR0_CA1		IO			1.1 V	VDDS_DDR, VDDS_DDR_C, VDDS_DDR_BIAS		DDR				
J4	DDR0_CA2	DDR0_CA2		IO			1.1 V	VDDS_DDR, VDDS_DDR_C, VDDS_DDR_BIAS		DDR				
K1	DDR0_CA3	DDR0_CA3		IO			1.1 V	VDDS_DDR, VDDS_DDR_C, VDDS_DDR_BIAS		DDR				
J2	DDR0_CA4	DDR0_CA4		IO			1.1 V	VDDS_DDR, VDDS_DDR_C, VDDS_DDR_BIAS		DDR				
H5	DDR0_CA5	DDR0_CA5		IO			1.1 V	VDDS_DDR, VDDS_DDR_C, VDDS_DDR_BIAS		DDR				
K5	DDR0_CAL0	DDR0_CAL0		A			1.1 V	VDDS_DDR, VDDS_DDR_C, VDDS_DDR_BIAS		DDRCALR				
G2	DDR0_CKE0	DDR0_CKE0		IO			1.1 V	VDDS_DDR, VDDS_DDR_C, VDDS_DDR_BIAS		DDR				
H2	DDR0_CKE1	DDR0_CKE1		IO			1.1 V	VDDS_DDR, VDDS_DDR_C, VDDS_DDR_BIAS		DDR				
G3	DDR0_CSn0_0	DDR0_CSn0_0		IO			1.1 V	VDDS_DDR, VDDS_DDR_C, VDDS_DDR_BIAS		DDR				

Table 6-1. Pin Attributes (continued)

BALL NUMBER [1]	BALL NAME [2]	SIGNAL NAME [3]	MUX MODE [4]	TYPE [5]	BALL RESET STATE [6]	BALL RESET REL. MUX MODE [7]	I/O VOLTAGE VALUE [8]	POWER [9]	HYS [10]	BUFFER TYPE [11]	PULL UP/DOWN TYPE [12]	DSIS [13]	RX ACTIVE/ TX DISABLE [14]	IO RET [15]
K2	DDR0_CSn0_1	DDR0_CSn0_1		IO			1.1 V	VDDS_DDR, VDDS_DDR_C, VDDS_DDR_BIAS		DDR				
G5	DDR0_CSn1_0	DDR0_CSn1_0		IO			1.1 V	VDDS_DDR, VDDS_DDR_C, VDDS_DDR_BIAS		DDR				
J3	DDR0_CSn1_1	DDR0_CSn1_1		IO			1.1 V	VDDS_DDR, VDDS_DDR_C, VDDS_DDR_BIAS		DDR				
A3	DDR0_DM0	DDR0_DM0		IO			1.1 V	VDDS_DDR, VDDS_DDR_C, VDDS_DDR_BIAS		DDR				
E4	DDR0_DM1	DDR0_DM1		IO			1.1 V	VDDS_DDR, VDDS_DDR_C, VDDS_DDR_BIAS		DDR				
N1	DDR0_DM2	DDR0_DM2		IO			1.1 V	VDDS_DDR, VDDS_DDR_C, VDDS_DDR_BIAS		DDR				
R4	DDR0_DM3	DDR0_DM3		IO			1.1 V	VDDS_DDR, VDDS_DDR_C, VDDS_DDR_BIAS		DDR				
B4	DDR0_DQ0	DDR0_DQ0		IO			1.1 V	VDDS_DDR, VDDS_DDR_C, VDDS_DDR_BIAS		DDR				
A4	DDR0_DQ1	DDR0_DQ1		IO			1.1 V	VDDS_DDR, VDDS_DDR_C, VDDS_DDR_BIAS		DDR				
C4	DDR0_DQ2	DDR0_DQ2		IO			1.1 V	VDDS_DDR, VDDS_DDR_C, VDDS_DDR_BIAS		DDR				
C1	DDR0_DQ3	DDR0_DQ3		IO			1.1 V	VDDS_DDR, VDDS_DDR_C, VDDS_DDR_BIAS		DDR				
C3	DDR0_DQ4	DDR0_DQ4		IO			1.1 V	VDDS_DDR, VDDS_DDR_C, VDDS_DDR_BIAS		DDR				
C2	DDR0_DQ5	DDR0_DQ5		IO			1.1 V	VDDS_DDR, VDDS_DDR_C, VDDS_DDR_BIAS		DDR				
A2	DDR0_DQ6	DDR0_DQ6		IO			1.1 V	VDDS_DDR, VDDS_DDR_C, VDDS_DDR_BIAS		DDR				
B3	DDR0_DQ7	DDR0_DQ7		IO			1.1 V	VDDS_DDR, VDDS_DDR_C, VDDS_DDR_BIAS		DDR				
D1	DDR0_DQ8	DDR0_DQ8		IO			1.1 V	VDDS_DDR, VDDS_DDR_C, VDDS_DDR_BIAS		DDR				

Table 6-1. Pin Attributes (continued)

BALL NUMBER [1]	BALL NAME [2]	SIGNAL NAME [3]	MUX MODE [4]	TYPE [5]	BALL RESET STATE [6]	BALL RESET REL. MUX MODE [7]	I/O VOLTAGE VALUE [8]	POWER [9]	HYS [10]	BUFFER TYPE [11]	PULL UP/DOWN TYPE [12]	DSIS [13]	RX ACTIVE/ TX DISABLE [14]	IO RET [15]
D2	DDR0_DQ9	DDR0_DQ9		IO			1.1 V	VDDS_DDR, VDDS_DDR_C, VDDS_DDR_BIAS		DDR				
F2	DDR0_DQ10	DDR0_DQ10		IO			1.1 V	VDDS_DDR, VDDS_DDR_C, VDDS_DDR_BIAS		DDR				
E3	DDR0_DQ11	DDR0_DQ11		IO			1.1 V	VDDS_DDR, VDDS_DDR_C, VDDS_DDR_BIAS		DDR				
F3	DDR0_DQ12	DDR0_DQ12		IO			1.1 V	VDDS_DDR, VDDS_DDR_C, VDDS_DDR_BIAS		DDR				
F4	DDR0_DQ13	DDR0_DQ13		IO			1.1 V	VDDS_DDR, VDDS_DDR_C, VDDS_DDR_BIAS		DDR				
D4	DDR0_DQ14	DDR0_DQ14		IO			1.1 V	VDDS_DDR, VDDS_DDR_C, VDDS_DDR_BIAS		DDR				
F5	DDR0_DQ15	DDR0_DQ15		IO			1.1 V	VDDS_DDR, VDDS_DDR_C, VDDS_DDR_BIAS		DDR				
K4	DDR0_DQ16	DDR0_DQ16		IO			1.1 V	VDDS_DDR, VDDS_DDR_C, VDDS_DDR_BIAS		DDR				
L4	DDR0_DQ17	DDR0_DQ17		IO			1.1 V	VDDS_DDR, VDDS_DDR_C, VDDS_DDR_BIAS		DDR				
M4	DDR0_DQ18	DDR0_DQ18		IO			1.1 V	VDDS_DDR, VDDS_DDR_C, VDDS_DDR_BIAS		DDR				
L3	DDR0_DQ19	DDR0_DQ19		IO			1.1 V	VDDS_DDR, VDDS_DDR_C, VDDS_DDR_BIAS		DDR				
L2	DDR0_DQ20	DDR0_DQ20		IO			1.1 V	VDDS_DDR, VDDS_DDR_C, VDDS_DDR_BIAS		DDR				
L1	DDR0_DQ21	DDR0_DQ21		IO			1.1 V	VDDS_DDR, VDDS_DDR_C, VDDS_DDR_BIAS		DDR				
M3	DDR0_DQ22	DDR0_DQ22		IO			1.1 V	VDDS_DDR, VDDS_DDR_C, VDDS_DDR_BIAS		DDR				
N2	DDR0_DQ23	DDR0_DQ23		IO			1.1 V	VDDS_DDR, VDDS_DDR_C, VDDS_DDR_BIAS		DDR				
R3	DDR0_DQ24	DDR0_DQ24		IO			1.1 V	VDDS_DDR, VDDS_DDR_C, VDDS_DDR_BIAS		DDR				

Table 6-1. Pin Attributes (continued)

BALL NUMBER [1]	BALL NAME [2]	SIGNAL NAME [3]	MUX MODE [4]	TYPE [5]	BALL RESET STATE [6]	BALL RESET REL. MUX MODE [7]	I/O VOLTAGE VALUE [8]	POWER [9]	HYS [10]	BUFFER TYPE [11]	PULL UP/DOWN TYPE [12]	DSIS [13]	RX ACTIVE/ TX DISABLE [14]	IO RET [15]
T1	DDR0_DQ25	DDR0_DQ25		IO			1.1 V	VDDS_DDR, VDDS_DDR_C, VDDS_DDR_BIAS		DDR				
P1	DDR0_DQ26	DDR0_DQ26		IO			1.1 V	VDDS_DDR, VDDS_DDR_C, VDDS_DDR_BIAS		DDR				
P2	DDR0_DQ27	DDR0_DQ27		IO			1.1 V	VDDS_DDR, VDDS_DDR_C, VDDS_DDR_BIAS		DDR				
N4	DDR0_DQ28	DDR0_DQ28		IO			1.1 V	VDDS_DDR, VDDS_DDR_C, VDDS_DDR_BIAS		DDR				
P3	DDR0_DQ29	DDR0_DQ29		IO			1.1 V	VDDS_DDR, VDDS_DDR_C, VDDS_DDR_BIAS		DDR				
P4	DDR0_DQ30	DDR0_DQ30		IO			1.1 V	VDDS_DDR, VDDS_DDR_C, VDDS_DDR_BIAS		DDR				
N5	DDR0_DQ31	DDR0_DQ31		IO			1.1 V	VDDS_DDR, VDDS_DDR_C, VDDS_DDR_BIAS		DDR				
B1	DDR0_DQS0N	DDR0_DQS0N		IO			1.1 V	VDDS_DDR, VDDS_DDR_C, VDDS_DDR_BIAS		DDR				
B2	DDR0_DQS0P	DDR0_DQS0P		IO			1.1 V	VDDS_DDR, VDDS_DDR_C, VDDS_DDR_BIAS		DDR				
E1	DDR0_DQS1N	DDR0_DQS1N		IO			1.1 V	VDDS_DDR, VDDS_DDR_C, VDDS_DDR_BIAS		DDR				
E2	DDR0_DQS1P	DDR0_DQS1P		IO			1.1 V	VDDS_DDR, VDDS_DDR_C, VDDS_DDR_BIAS		DDR				
M1	DDR0_DQS2N	DDR0_DQS2N		IO			1.1 V	VDDS_DDR, VDDS_DDR_C, VDDS_DDR_BIAS		DDR				
M2	DDR0_DQS2P	DDR0_DQS2P		IO			1.1 V	VDDS_DDR, VDDS_DDR_C, VDDS_DDR_BIAS		DDR				
R1	DDR0_DQS3N	DDR0_DQS3N		IO			1.1 V	VDDS_DDR, VDDS_DDR_C, VDDS_DDR_BIAS		DDR				
R2	DDR0_DQS3P	DDR0_DQS3P		IO			1.1 V	VDDS_DDR, VDDS_DDR_C, VDDS_DDR_BIAS		DDR				
R5	DDR_RET	DDR_RET		I			1.1 V	VDDS_DDR, VDDS_DDR_C, VDDS_DDR_BIAS		DDR				

Table 6-1. Pin Attributes (continued)

BALL NUMBER [1]	BALL NAME [2]	SIGNAL NAME [3]	MUX MODE [4]	TYPE [5]	BALL RESET STATE [6]	BALL RESET REL. MUX MODE [7]	I/O VOLTAGE VALUE [8]	POWER [9]	HYS [10]	BUFFER TYPE [11]	PULL UP/DOWN TYPE [12]	DSIS [13]	RX ACTIVE/ TX DISABLE [14]	IO RET [15]
U3	ECAP0_IN_APWM_OUT	ECAP0_IN_APWM_OUT	0	IO	OFF	7	1.8 V/3.3 V	VDDSHV0	Yes	LVCMOS	PU/PD	0		
		SYNC0_OUT	1	O										
		CPTS0_RFT_CLK	2	I										
		I2C1_SCL	3	IOD										
		CPTS0_HW1TSPUSH	4	I										
		UART3_RXD	5	I										
		SPI7_CS0	6	IO										
		GPIO0_58	7	IO								pad		
A13	EMU0	EMU0	0	IO	OFF	0	1.8 V/3.3 V	VDDSHV0_MCU	Yes	LVCMOS	PU/PD		0/0	
D12	EMU1	EMU1	0	IO	OFF	0	1.8 V/3.3 V	VDDSHV0_MCU	Yes	LVCMOS	PU/PD		0/0	
U6	EXTINTn	EXTINTn	0	I	OFF	7	1.8 V/3.3 V	VDDSHV0	Yes	I2C OD FS		1		
		GPIO0_0	7	IO								pad		
T3	EXT_REFCLK1	EXT_REFCLK1	0	I	OFF	7	1.8 V/3.3 V	VDDSHV0	Yes	LVCMOS	PU/PD	0		
		SYNC1_OUT	1	O										
		I2C1_SDA	3	IOD										
		CPTS0_HW2TSPUSH	4	I										
		UART3_TXD	5	O										
		SPI7_CLK	6	IO										
		GPIO0_59	7	IO								pad		
U12	GPIO0_41	RGMI12_TX_CTL	4	O	OFF	7	1.8 V/3.3 V	VDDSHV2	Yes	LVCMOS	PU/PD			Yes
		RMII2_TXD0	5	O										
		GPIO0_41	7	IO								pad		
		SPI6_D1	8	IO								0		
		UART4_RXD	11	I								1		
		MCASP2_ACLKX	12	IO								0		
		GPMC0_A13	13	OZ										
U13	GPMC0_CLK	GPMC0_CLK	0	IO	OFF	7	1.8 V/3.3 V	VDDSHV2	Yes	LVCMOS	PU/PD	0		Yes
		USB0_DRVVBUS	1	O										
		RGMI14_RD3	4	I								0		
		GPIO0_44	7	IO								pad		
		SPI0_CS3	10	IO								1		
		UART9_RXD	11	I								1		
V3	I2C0_SCL	I2C0_SCL	0	IOD	OFF	7	1.8 V/3.3 V	VDDSHV0	Yes	I2C OD FS		1		
		GPIO0_56	7	IO								pad		
W2	I2C0_SDA	I2C0_SDA	0	IOD	OFF	7	1.8 V/3.3 V	VDDSHV0	Yes	I2C OD FS		1		
		GPIO0_57	7	IO								pad		

Table 6-1. Pin Attributes (continued)

BALL NUMBER [1]	BALL NAME [2]	SIGNAL NAME [3]	MUX MODE [4]	TYPE [5]	BALL RESET STATE [6]	BALL RESET REL. MUX MODE [7]	I/O VOLTAGE VALUE [8]	POWER [9]	HYS [10]	BUFFER TYPE [11]	PULL UP/DOWN TYPE [12]	DSIS [13]	RX ACTIVE/ TX DISABLE [14]	IO RET [15]
V20	MCAN0_RX	MCAN0_RX	0	I	OFF	7	1.8 V/3.3 V	VDDSHV2	Yes	LVCMOS	PU/PD	1	1/0	Yes
		RGMI4_RD1	4	I								0		
		MCAN0_RX	6	I								1		
		GPIO0_10	7	IO								pad		
		EQEP2_S	9	IO								0		
		GPMC0_A2	11	OZ										
		MCASP0_AXR10	12	IO								0		
V18	MCAN0_TX	MCAN0_TX	0	O	OFF	7	1.8 V/3.3 V	VDDSHV2	Yes	LVCMOS	PU/PD		1/0	Yes
		RGMI4_RD0	4	I								0		
		MCAN0_TX	6	O										
		GPIO0_9	7	IO								pad		
		EQEP2_B	9	I								0		
		GPMC0_A1	11	OZ										
		MCASP0_AXR9	12	IO								0		
AUDIO_EXT_REFCLK0	14	IO	0											
V16	MCAN1_RX	MCAN1_RX	0	I	OFF	7	1.8 V/3.3 V	VDDSHV2	Yes	LVCMOS	PU/PD	1	1/0	Yes
		RGMI4_RD2	4	I								0		
		RMII2_TXD1	5	O										
		MCAN1_RX	6	I								1		
		GPIO0_12	7	IO								pad		
		SPI6_CS1	8	IO								1		
		EQEP2_I	9	IO								0		
		GPMC0_AD7	10	IO								0		
		UART6_CTSn	11	I								1		
		MCASP0_AXR12	12	IO								0		
		OBSCLK1	14	O										
W21	MCAN1_TX	MCAN1_TX	0	O	OFF	7	1.8 V/3.3 V	VDDSHV2	Yes	LVCMOS	PU/PD		1/0	Yes
		RGMI2_TXC	4	O										
		RMII2_TX_EN	5	O										
		MCAN1_TX	6	O										
		GPIO0_11	7	IO								pad		
		SPI6_CS0	8	IO								1		
		EHRPWM_SOCA	9	O										
		GPMC0_A3	11	OZ										
MCASP0_AXR11	12	IO	0											

Table 6-1. Pin Attributes (continued)

BALL NUMBER [1]	BALL NAME [2]	SIGNAL NAME [3]	MUX MODE [4]	TYPE [5]	BALL RESET STATE [6]	BALL RESET REL. MUX MODE [7]	I/O VOLTAGE VALUE [8]	POWER [9]	HYS [10]	BUFFER TYPE [11]	PULL UP/DOWN TYPE [12]	DSIS [13]	RX ACTIVE/ TX DISABLE [14]	IO RET [15]											
Y19	MCAN2_RX	MCAN2_RX	0	I	OFF	7	1.8 V/3.3 V	VDDSHV2		LVCMOS	PU/PD	1	1/0	Yes											
		RGMI1_TD1	4	O																					
		RMII4_RXD1	5	I								0													
		MCAN2_RX	6	I								1													
		GPIO0_14	7	IO								pad													
		SPI5_CS2	8	IO								1													
		EHRPWM0_B	9	IO								0													
		TRC_DATA2	10	O																					
		UART3_TXD	11	O																					
		MCASP1_ACLKX	12	IO								0													
		UART9_RTSn	13	O																					
		GPMC0_AD9	14	IO								0													
		Y18	MCAN2_TX	MCAN2_TX								0			O	OFF	7	1.8 V/3.3 V	VDDSHV2		LVCMOS	PU/PD		1/0	Yes
				RGMI1_TD0								4			O										
RMII4_RXD0	5			I	0																				
MCAN2_TX	6			O																					
GPIO0_13	7			IO	pad																				
SPI5_CS3	8			IO	1																				
EHRPWM1_A	9			IO	1																				
TRC_DATA3	10			O																					
UART3_RXD	11			I	1																				
MCASP1_AFSX	12			IO	0																				
UART9_CTSn	13			I	1																				
GPMC0_AD8	14			IO	0																				
W16	MCAN3_RX			MCAN3_RX	0	I	OFF	7	1.8 V/3.3 V	VDDSHV2		LVCMOS	PU/PD	1	1/0								Yes		
				RGMI1_TD3	4	O																			
		RMII4_RX_ER	5	I	0																				
		MCAN3_RX	6	I	1																				
		GPIO0_16	7	IO	pad																				
		SPI5_CS0	8	IO	1																				
		EHRPWM_TZn_IN0	9	I	0																				
		TRC_DATA0	10	O																					
		GPMC0_A4	11	OZ																					
		MCASP0_AXR0	12	IO	0																				
		SYNC2_OUT	14	O																					

Table 6-1. Pin Attributes (continued)

BALL NUMBER [1]	BALL NAME [2]	SIGNAL NAME [3]	MUX MODE [4]	TYPE [5]	BALL RESET STATE [6]	BALL RESET REL. MUX MODE [7]	I/O VOLTAGE VALUE [8]	POWER [9]	HYS [10]	BUFFER TYPE [11]	PULL UP/DOWN TYPE [12]	DSIS [13]	RX ACTIVE/ TX DISABLE [14]	IO RET [15]
Y21	MCAN3_TX	MCAN3_TX	0	O	OFF	7	1.8 V/3.3 V	VDDSHV2	Yes	LVCMOS	PU/PD		1/0	Yes
		RGMI1_TD2	4	O										
		RMII4_CRS_DV	5	I								0		
		MCAN3_TX	6	O										
		GPIO0_15	7	IO								pad		
		SPI5_D0	8	IO								0		
		EHRPWM0_A	9	IO								0		
		TRC_DATA1	10	O										
		MCASP0_AXR1	12	IO								0		
		GPMC0_AD10	14	IO								0		
Y20	MCAN4_RX	MCAN4_RX	0	I	OFF	7	1.8 V/3.3 V	VDDSHV2	Yes	LVCMOS	PU/PD	1	1/0	Yes
		RGMI1_TXC	4	O										
		RMII4_TX_EN	5	O										
		MCAN4_RX	6	I								1		
		GPIO0_18	7	IO								pad		
		SPI5_D1	8	IO								0		
		EHRPWM1_B	9	IO								0		
		TRC_DATA4	10	O										
		I2C2_SDA	11	IOD								1		
		MCASP0_AXR2	12	IO								0		
GPMC0_AD12	14	IO	0											
W15	MCAN4_TX	MCAN4_TX	0	O	OFF	7	1.8 V/3.3 V	VDDSHV2	Yes	LVCMOS	PU/PD		1/0	Yes
		RGMI1_TX_CTL	4	O										
		RMII4_TXD0	5	O										
		MCAN4_TX	6	O										
		GPIO0_17	7	IO								pad		
		SPI5_CLK	8	IO								0		
		EHRPWM0_SYNCI	9	I								0		
		TRC_CLK	10	O										
		I2C2_SCL	11	IOD								1		
		MCASP0_ACLKX	12	IO								0		
GPMC0_AD11	14	IO	0											

Table 6-1. Pin Attributes (continued)

BALL NUMBER [1]	BALL NAME [2]	SIGNAL NAME [3]	MUX MODE [4]	TYPE [5]	BALL RESET STATE [6]	BALL RESET REL. MUX MODE [7]	I/O VOLTAGE VALUE [8]	POWER [9]	HYS [10]	BUFFER TYPE [11]	PULL UP/DOWN TYPE [12]	DSIS [13]	RX ACTIVE/ TX DISABLE [14]	IO RET [15]
V19	MCAN5_RX	MCAN5_RX	0	I	OFF	7	1.8 V/3.3 V	VDDSHV2	Yes	LVCMOS	PU/PD	1	1/0	Yes
		RGMI3_RD0	4	I								0		
		RMII3_RXD0	5	I								0		
		MCAN5_RX	6	I								1		
		GPIO0_20	7	IO								pad		
		I2C3_SCL	8	IOD								1		
		EHRPWM_TZn_IN5	9	I								0		
		TRC_DATA21	10	O										
		GPMC0_A5	11	OZ										
		MCASP1_AXR7	12	IO								0		
V21	MCAN5_TX	MCAN5_TX	0	O	OFF	7	1.8 V/3.3 V	VDDSHV2	Yes	LVCMOS	PU/PD		1/0	Yes
		RGMI3_RXC	4	I								0		
		RMII4_TXD1	5	O										
		MCAN5_TX	6	O										
		GPIO0_19	7	IO								pad		
		SPI5_CS1	8	IO								1		
		EHRPWM4_B	9	IO								0		
		TRC_DATA17	10	O										
		UART6_RTSn	11	O										
		MCASP0_AXR7	12	IO								0		
GPMC0_DIR	13	O												
SYNC3_OUT	14	O												
U14	MCAN6_RX	MCAN6_RX	0	I	OFF	7	1.8 V/3.3 V	VDDSHV2	Yes	LVCMOS	PU/PD	1	1/0	Yes
		RGMI3_RD2	4	I								0		
		RMII3_CRSDV	5	I								0		
		MCAN6_RX	6	I								1		
		GPIO0_22	7	IO								pad		
		EHRPWM5_A	9	IO								0		
		TRC_DATA19	10	O										
		MCASP1_AXR5	12	IO								0		
GPMC0_AD13	14	IO	0											

Table 6-1. Pin Attributes (continued)

BALL NUMBER [1]	BALL NAME [2]	SIGNAL NAME [3]	MUX MODE [4]	TYPE [5]	BALL RESET STATE [6]	BALL RESET REL. MUX MODE [7]	I/O VOLTAGE VALUE [8]	POWER [9]	HYS [10]	BUFFER TYPE [11]	PULL UP/DOWN TYPE [12]	DSIS [13]	RX ACTIVE/ TX DISABLE [14]	IO RET [15]
T13	MCAN6_TX	MCAN6_TX	0	O	OFF	7	1.8 V/3.3 V	VDDSHV2		LVCMOS	PU/PD		1/0	Yes
		RGMI13_RD1	4	I								0		
		RMII3_RXD1	5	I								0		
		MCAN6_TX	6	O										
		GPIO0_21	7	IO								pad		
		I2C3_SDA	8	IOD								1		
		EHRPWM5_B	9	IO								0		
		TRC_DATA20	10	O										
		GPMC0_A6	11	OZ										
		MCASP1_AXR6	12	IO								0		
U15	MCAN7_RX	MCAN7_RX	0	I	OFF	7	1.8 V/3.3 V	VDDSHV2		LVCMOS	PU/PD	1	1/0	Yes
		RGMI13_RX_CTL	4	I								0		
		RMII3_TXD0	5	O										
		MCAN7_RX	6	I								1		
		GPIO0_24	7	IO								pad		
		SPI3_CS1	8	IO								1		
		EHRPWM3_A	9	IO								0		
		TRC_DATA11	10	O										
		MCASP0_AFSR	12	IO								0		
		GPMC0_AD15	14	IO								0		
U16	MCAN7_TX	MCAN7_TX	0	O	OFF	7	1.8 V/3.3 V	VDDSHV2		LVCMOS	PU/PD		1/0	Yes
		RGMI13_RD3	4	I								0		
		RMII3_RX_ER	5	I								0		
		MCAN7_TX	6	O										
		GPIO0_23	7	IO								pad		
		SPI3_CS0	8	IO								1		
		EHRPWM_TZn_IN4	9	I								0		
		TRC_DATA18	10	O										
		MCASP1_AXR4	12	IO								0		
		GPMC0_AD14	14	IO								0		

Table 6-1. Pin Attributes (continued)

BALL NUMBER [1]	BALL NAME [2]	SIGNAL NAME [3]	MUX MODE [4]	TYPE [5]	BALL RESET STATE [6]	BALL RESET REL. MUX MODE [7]	I/O VOLTAGE VALUE [8]	POWER [9]	HYS [10]	BUFFER TYPE [11]	PULL UP/DOWN TYPE [12]	DSIS [13]	RX ACTIVE/ TX DISABLE [14]	IO RET [15]
U19	MCAN8_RX	MCAN8_RX	0	I	OFF	7	1.8 V/3.3 V	VDDSHV2		LVCMOS	PU/PD	1	1/0	Yes
		RGMI3_TD1	4	O										
		RMI3_TXD1	5	O										
		MCAN8_RX	6	I								1		
		GPIO0_26	7	IO								pad		
		SPI3_CS3	8	IO								1		
		EHRPWM3_SYNCO	9	O										
		TRC_DATA14	10	O										
		UART3_RTSn	11	O										
		MCASP0_AXR4	12	IO								0		
		GPMC0_A8	13	OZ										
		UART0_DSRn	14	I								1		
		T15	MCAN8_TX	MCAN8_TX								0		
GPMC0_A7	3			OZ										
RGMI3_TD0	4			O										
RMI3_TX_EN	5			O										
MCAN8_TX	6			O										
GPIO0_25	7			IO	pad									
SPI3_CS2	8			IO	1									
EHRPWM_TZn_IN3	9			I	0									
TRC_DATA15	10			O										
UART3_CTSn	11			I	1									
MCASP0_AXR5	12			IO	0									
UART0_DCDn	14			I	1									
U18	MCAN9_RX			MCAN9_RX	0	I	OFF	7	1.8 V/3.3 V	VDDSHV2		LVCMOS	PU/PD	1
		RGMI3_TD3	4	O										
		MCAN9_RX	6	I	1									
		GPIO0_28	7	IO	pad									
		SPI3_D0	8	IO	0									
		EHRPWM3_B	9	IO	0									
		TRC_DATA12	10	O										
		MCASP1_ACLKR	12	IO	0									
		GPMC0_A10	13	OZ										
		MCASP1_AXR11	14	IO	0									

Table 6-1. Pin Attributes (continued)

BALL NUMBER [1]	BALL NAME [2]	SIGNAL NAME [3]	MUX MODE [4]	TYPE [5]	BALL RESET STATE [6]	BALL RESET REL. MUX MODE [7]	I/O VOLTAGE VALUE [8]	POWER [9]	HYS [10]	BUFFER TYPE [11]	PULL UP/DOWN TYPE [12]	DSIS [13]	RX ACTIVE/ TX DISABLE [14]	IO RET [15]
T14	MCAN9_TX	MCAN9_TX	0	O	OFF	7	1.8 V/3.3 V	VDDSHV2	Yes	LVCMOS	PU/PD		1/0	Yes
		RGMI3_TD2	4	O										
		MCAN9_TX	6	O										
		GPIO0_27	7	IO								pad		
		SPI3_CLK	8	IO								0		
		EHRPWM3_SYNCI	9	I								0		
		TRC_DATA13	10	O										
		MCASP1_AFSR	12	IO								0		
		GPMC0_A9	13	OZ										
MCASP1_AXR10	14	IO	0											
U20	MCAN10_RX	MCAN10_RX	0	I	OFF	7	1.8 V/3.3 V	VDDSHV2	Yes	LVCMOS	PU/PD	1	1/0	Yes
		RGMI3_TXC	4	O										
		MCAN10_RX	6	I								1		
		GPIO0_30	7	IO								pad		
		SPI2_CLK	8	IO								1		
		EHRPWM4_A	9	IO								0		
		TRC_DATA16	10	O										
		UART2_RTSn	11	O										
		MCASP0_AXR6	12	IO								0		
		GPMC0_BE0n_CLE	13	O										
		GPMC0_A16	14	OZ										
U17	MCAN10_TX	MCAN10_TX	0	O	OFF	7	1.8 V/3.3 V	VDDSHV2	Yes	LVCMOS	PU/PD		1/0	Yes
		RGMI3_TX_CTL	4	O										
		MCAN10_TX	6	O										
		GPIO0_29	7	IO								pad		
		SPI3_D1	8	IO								0		
		EHRPWM_SOCB	9	O										
		TRC_DATA10	10	O										
		UART2_CTSn	11	I								1		
		MCASP0_ACLKR	12	IO								0		
		GPMC0_WAIT1	13	I								0		
GPMC0_A22	14	OZ												

Table 6-1. Pin Attributes (continued)

BALL NUMBER [1]	BALL NAME [2]	SIGNAL NAME [3]	MUX MODE [4]	TYPE [5]	BALL RESET STATE [6]	BALL RESET REL. MUX MODE [7]	I/O VOLTAGE VALUE [8]	POWER [9]	HYS [10]	BUFFER TYPE [11]	PULL UP/DOWN TYPE [12]	DSIS [13]	RX ACTIVE/ TX DISABLE [14]	IO RET [15]
Y13	MCAN11_RX	MCAN11_RX	0	I	OFF	7	1.8 V/3.3 V	VDDSHV2	Yes	LVCMOS	PU/PD	1	1/0	Yes
		RGMI2_RD0	4	I								0		
		MCAN11_RX	6	I								1		
		GPIO0_32	7	IO								pad		
		SPI2_CS1	8	IO								1		
		EQEP0_B	9	I								0		
		UART3_TXD	11	O										
		MCASP0_AXR14	12	IO								0		
		GPMC0_A12	13	OZ										
		UART0_RIn	14	I								1		
Y14	MCAN11_TX	MCAN11_TX	0	O	OFF	7	1.8 V/3.3 V	VDDSHV2	Yes	LVCMOS	PU/PD		1/0	Yes
		RGMI2_RXC	4	I								0		
		MCAN11_TX	6	O										
		GPIO0_31	7	IO								pad		
		SPI2_CS0	8	IO								1		
		EQEP0_A	9	I								0		
		SPI0_CS2	10	IO								1		
		UART3_RXD	11	I								1		
		MCASP0_AXR13	12	IO								0		
		GPMC0_A11	13	OZ										
UART0_DTRn	14	O												
AA14	MCAN12_RX	MCAN12_RX	0	I	OFF	7	1.8 V/3.3 V	VDDSHV2	Yes	LVCMOS	PU/PD	1	1/0	Yes
		RGMI2_RD2	4	I								0		
		MCAN12_RX	6	I								1		
		GPIO0_34	7	IO								pad		
		SPI2_CS3	8	IO								1		
		EQEP1_B	9	I								0		
		I2C6_SDA	10	IOD								1		
		UART2_TXD	11	O										
		MCASP1_AXR8	12	IO								0		
		I3C0_SDAPULLEN	13	OD										
GPMC0_A18	14	OZ												

Table 6-1. Pin Attributes (continued)

BALL NUMBER [1]	BALL NAME [2]	SIGNAL NAME [3]	MUX MODE [4]	TYPE [5]	BALL RESET STATE [6]	BALL RESET REL. MUX MODE [7]	I/O VOLTAGE VALUE [8]	POWER [9]	HYS [10]	BUFFER TYPE [11]	PULL UP/DOWN TYPE [12]	DSIS [13]	RX ACTIVE/ TX DISABLE [14]	IO RET [15]											
AA15	MCAN12_TX	MCAN12_TX	0	O	OFF	7	1.8 V/3.3 V	VDDSHV2		LVCMOS	PU/PD		1/0	Yes											
		RGMI2_RD1	4	I								0													
		MCAN12_TX	6	O																					
		GPIO0_33	7	IO								pad													
		SPI2_CS2	8	IO								1													
		EQEP1_A	9	I								0													
		I2C6_SCL	10	IOD								1													
		UART2_RXD	11	I								1													
		MCASP0_AXR15	12	IO								0													
		GPMC0_BE1n	13	O																					
		GPMC0_A17	14	OZ																					
AA16	MCAN13_RX	MCAN13_RX	0	I	OFF	7	1.8 V/3.3 V	VDDSHV2		LVCMOS	PU/PD	1	1/0	Yes											
		RGMI2_RX_CTL	4	I								0													
		GPMC0_CS3	5	O																					
		MCAN13_RX	6	I								1													
		GPIO0_36	7	IO								pad													
		SPI2_D1	8	IO								0													
		EQEP0_I	9	IO								0													
		I2C5_SDA	10	IOD								1													
		UART8_RTSn	11	O																					
		MCASP2_AXR0	12	IO								0													
		I3C0_SDA	13	IO								1													
		GPMC0_A20	14	OZ																					
		AA18	MCAN13_TX	MCAN13_TX								0			O	OFF	7	1.8 V/3.3 V	VDDSHV2		LVCMOS	PU/PD		1/0	Yes
				RGMI2_RD3								4			I								0		
GPMC0_WPn	5			O																					
MCAN13_TX	6			O																					
GPIO0_35	7			IO	pad																				
SPI2_D0	8			IO	0																				
EQEP0_S	9			IO	0																				
I2C5_SCL	10			IOD	1																				
UART8_CTSn	11			I	1																				
MCASP1_AXR9	12			IO	0																				
I3C0_SCL	13			IO	1																				
GPMC0_A19	14			OZ																					

Table 6-1. Pin Attributes (continued)

BALL NUMBER [1]	BALL NAME [2]	SIGNAL NAME [3]	MUX MODE [4]	TYPE [5]	BALL RESET STATE [6]	BALL RESET REL. MUX MODE [7]	I/O VOLTAGE VALUE [8]	POWER [9]	HYS [10]	BUFFER TYPE [11]	PULL UP/DOWN TYPE [12]	DSIS [13]	RX ACTIVE/ TX DISABLE [14]	IO RET [15]
W20	MCAN15_RX	MCAN15_RX	0	I	OFF	7	1.8 V/3.3 V	VDDSHV2	Yes	LVCMOS	PU/PD	1	1/0	Yes
		RGMI2_TD1	4	O										
		RMII2_RXD1	5	I								0		
		GPIO0_38	7	IO								pad		
		SPI6_CS3	8	IO								1		
		EQEP1_I	9	IO								0		
		MCAN15_RX	10	I								1		
		MCASP2_AXR2	12	IO								0		
		GPMC0_A15	13	OZ										
GPMC0_ADVn_ALE	14	O												
W17	MCAN15_TX	MCAN15_TX	0	O	OFF	7	1.8 V/3.3 V	VDDSHV2	Yes	LVCMOS	PU/PD		1/0	Yes
		RGMI2_TD0	4	O										
		RMII2_RXD0	5	I								0		
		GPIO0_37	7	IO								pad		
		SPI6_CS2	8	IO								1		
		EQEP1_S	9	IO								0		
		MCAN15_TX	10	O										
		GPMC0_CSn2	11	O										
		MCASP2_AXR1	12	IO								0		
GPMC0_A0	13	OZ												
GPMC0_A21	14	OZ												
U21	MCAN16_RX	MCAN16_RX	0	I	OFF	7	1.8 V/3.3 V	VDDSHV2	Yes	LVCMOS	PU/PD	1	1/0	Yes
		CLKOUT	1	OZ										
		RGMI4_TD0	4	O										
		GPIO0_46	7	IO								pad		
		UART7_RXD	12	I								1		
		GPMC0_CSn1	13	O										
AUDIO_EXT_REFCLK1	14	IO	0											
V15	MCAN16_TX	MCAN16_TX	0	O	OFF	7	1.8 V/3.3 V	VDDSHV2	Yes	LVCMOS	PU/PD		1/0	Yes
		RMII_REF_CLK	1	I								0		
		RGMI4_RX_CTL	4	I								0		
		GPIO0_45	7	IO								pad		
		UART7_TXD	12	O										
GPMC0_A14	13	OZ												
H17	MCU_ADC0_AIN0	MCU_ADC0_AIN0	0	A		0	1.8 V	VDDA_ADC_MCU		ADC12BT				
K18	MCU_ADC0_AIN1	MCU_ADC0_AIN1	0	A		0	1.8 V	VDDA_ADC_MCU		ADC12BT				
M17	MCU_ADC0_AIN2	MCU_ADC0_AIN2	0	A		0	1.8 V	VDDA_ADC_MCU		ADC12BT				

Table 6-1. Pin Attributes (continued)

BALL NUMBER [1]	BALL NAME [2]	SIGNAL NAME [3]	MUX MODE [4]	TYPE [5]	BALL RESET STATE [6]	BALL RESET REL. MUX MODE [7]	I/O VOLTAGE VALUE [8]	POWER [9]	HYS [10]	BUFFER TYPE [11]	PULL UP/DOWN TYPE [12]	DSIS [13]	RX ACTIVE/ TX DISABLE [14]	IO RET [15]
L18	MCU_ADC0_AIN3	MCU_ADC0_AIN3	0	A		0	1.8 V	VDDA_ADC_MCU		ADC12BT				
J18	MCU_ADC0_AIN4	MCU_ADC0_AIN4	0	A		0	1.8 V	VDDA_ADC_MCU		ADC12BT				
J17	MCU_ADC0_AIN5	MCU_ADC0_AIN5	0	A		0	1.8 V	VDDA_ADC_MCU		ADC12BT				
K17	MCU_ADC0_AIN6	MCU_ADC0_AIN6	0	A		0	1.8 V	VDDA_ADC_MCU		ADC12BT				
L17	MCU_ADC0_AIN7	MCU_ADC0_AIN7	0	A		0	1.8 V	VDDA_ADC_MCU		ADC12BT				
G21	MCU_I2C0_SCL	MCU_I2C0_SCL	0	IOD	OFF	0	1.8 V/3.3 V	VDDSHV0_MCU	Yes	I2C OD FS		1		Yes
		WKUP_GPIO0_66	7	IO		pad								
G20	MCU_I2C0_SDA	MCU_I2C0_SDA	0	IOD	OFF	0	1.8 V/3.3 V	VDDSHV0_MCU	Yes	I2C OD FS		1		Yes
		WKUP_GPIO0_67	7	IO		pad								
A17	MCU_MCAN0_RX	MCU_MCAN0_RX	0	I	OFF	7	1.8 V/3.3 V	VDDSHV0_MCU	Yes	LVCMOS	PU/PD	0	1/0	Yes
		WKUP_GPIO0_63	7	IO		pad								
A16	MCU_MCAN0_TX	MCU_MCAN0_TX	0	O	OFF	7	1.8 V/3.3 V	VDDSHV0_MCU	Yes	LVCMOS	PU/PD		1/0	Yes
		WKUP_GPIO0_62	7	IO		pad								
D9	MCU_MDIO0_MDC	MCU_MDIO0_MDC	0	O	OFF	7	1.8 V/3.3 V	VDDSHV2_MCU	Yes	LVCMOS	PU/PD		1/0	
		WKUP_GPIO0_55	7	IO		pad								
C9	MCU_MDIO0_MDIO	MCU_MDIO0_MDIO	0	IO	OFF	7	1.8 V/3.3 V	VDDSHV2_MCU	Yes	LVCMOS	PU/PD	0	1/0	
		WKUP_GPIO0_54	7	IO		pad								
B6	MCU_OSPI0_CLK	MCU_OSPI0_CLK	0	O	OFF	7	1.8 V/3.3 V	VDDSHV1_MCU	Yes	LVCMOS	PU/PD			
		MCU_HYPERBUS0_CK	1	O										
		WKUP_GPIO0_16	7	IO		pad								
B7	MCU_OSPI0_DQS	MCU_OSPI0_DQS	0	I	OFF	7	1.8 V/3.3 V	VDDSHV1_MCU	Yes	LVCMOS	PU/PD	0		
		MCU_HYPERBUS0_RWDS	1	IO										
		WKUP_GPIO0_18	7	IO		pad								
C8	MCU_OSPI0_LBCLKO	MCU_OSPI0_LBCLKO	0	IO	OFF	7	1.8 V/3.3 V	VDDSHV1_MCU	Yes	LVCMOS	PU/PD	0		
		MCU_HYPERBUS0_CK _n	1	O										
		WKUP_GPIO0_17	7	IO		pad								
D6	MCU_OSPI0_CS _{n0}	MCU_OSPI0_CS _{n0}	0	O	OFF	7	1.8 V/3.3 V	VDDSHV1_MCU	Yes	LVCMOS	PU/PD		1/0	
		MCU_HYPERBUS0_CS _{n0}	1	O										
		WKUP_GPIO0_27	7	IO		pad								
D7	MCU_OSPI0_CS _{n1}	MCU_OSPI0_CS _{n1}	0	O	OFF	7	1.8 V/3.3 V	VDDSHV1_MCU	Yes	LVCMOS	PU/PD		1/0	
		MCU_HYPERBUS0_RESET _n	1	O										
		WKUP_GPIO0_28	7	IO		pad								

Table 6-1. Pin Attributes (continued)

BALL NUMBER [1]	BALL NAME [2]	SIGNAL NAME [3]	MUX MODE [4]	TYPE [5]	BALL RESET STATE [6]	BALL RESET REL. MUX MODE [7]	I/O VOLTAGE VALUE [8]	POWER [9]	HYS [10]	BUFFER TYPE [11]	PULL UP/DOWN TYPE [12]	DSIS [13]	RX ACTIVE/ TX DISABLE [14]	IO RET [15]
C6	MCU_OSPI0_CSn2	MCU_OSPI0_CSn2	0	O	OFF	7	1.8 V/3.3 V	VDDSHV1_MCU	Yes	LVCMOS	PU/PD			
		MCU_OSPI0_CSn2	1	O										
		MCU_HYPERBUS0_RESETO _n	2	I								I		
		MCU_HYPERBUS0_WP _n	3	O										
		MCU_HYPERBUS0_CS _{n1}	4	O										
		MCU_OSPI0_RESET_OUT0	6	O										
		WKUP_GPIO0_30	7	IO								pad		
D5	MCU_OSPI0_CS _{n3}	MCU_OSPI0_CS _{n3}	0	O	OFF	7	1.8 V/3.3 V	VDDSHV1_MCU	Yes	LVCMOS	PU/PD			
		MCU_OSPI0_CS _{n3}	1	O										
		MCU_HYPERBUS0_INT _n	2	I								I		
		MCU_HYPERBUS0_WP _n	3	O										
		MCU_OSPI0_RESET_OUT1	5	O										
		MCU_OSPI0_ECC_FAIL	6	I								1		
		WKUP_GPIO0_31	7	IO								pad		
D8	MCU_OSPI0_D0	MCU_OSPI0_D0	0	IO	OFF	7	1.8 V/3.3 V	VDDSHV1_MCU	Yes	LVCMOS	PU/PD	0	1/0	
		MCU_HYPERBUS0_DQ0	1	IO								0		
		WKUP_GPIO0_19	7	IO								pad		
		BOOTMODE00	Bootstrap	I										
C7	MCU_OSPI0_D1	MCU_OSPI0_D1	0	IO	OFF	7	1.8 V/3.3 V	VDDSHV1_MCU	Yes	LVCMOS	PU/PD	0	1/0	
		MCU_HYPERBUS0_DQ1	1	IO								0		
		WKUP_GPIO0_20	7	IO								pad		
		BOOTMODE01	Bootstrap	I										
C5	MCU_OSPI0_D2	MCU_OSPI0_D2	0	IO	OFF	7	1.8 V/3.3 V	VDDSHV1_MCU	Yes	LVCMOS	PU/PD	0	1/0	
		MCU_HYPERBUS0_DQ2	1	IO								0		
		WKUP_GPIO0_21	7	IO								pad		
A5	MCU_OSPI0_D3	MCU_OSPI0_D3	0	IO	OFF	7	1.8 V/3.3 V	VDDSHV1_MCU	Yes	LVCMOS	PU/PD	0	1/0	
		MCU_HYPERBUS0_DQ3	1	IO								0		
		WKUP_GPIO0_22	7	IO								pad		
A6	MCU_OSPI0_D4	MCU_OSPI0_D4	0	IO	OFF	7	1.8 V/3.3 V	VDDSHV1_MCU	Yes	LVCMOS	PU/PD	0	1/0	
		MCU_HYPERBUS0_DQ4	1	IO								0		
		WKUP_GPIO0_23	7	IO								pad		
		BOOTMODE02	Bootstrap	I										
B8	MCU_OSPI0_D5	MCU_OSPI0_D5	0	IO	OFF	7	1.8 V/3.3 V	VDDSHV1_MCU	Yes	LVCMOS	PU/PD	0	1/0	
		MCU_HYPERBUS0_DQ5	1	IO								0		
		WKUP_GPIO0_24	7	IO								pad		
		BOOTMODE03	Bootstrap	I										

Table 6-1. Pin Attributes (continued)

BALL NUMBER [1]	BALL NAME [2]	SIGNAL NAME [3]	MUX MODE [4]	TYPE [5]	BALL RESET STATE [6]	BALL RESET REL. MUX MODE [7]	I/O VOLTAGE VALUE [8]	POWER [9]	HYS [10]	BUFFER TYPE [11]	PULL UP/DOWN TYPE [12]	DSIS [13]	RX ACTIVE/ TX DISABLE [14]	IO RET [15]
A8	MCU_OSPIO_D6	MCU_OSPIO_D6	0	IO	OFF	7	1.8 V/3.3 V	VDDSHV1_MCU	Yes	LVCMOS	PU/PD	0	1/0	
		MCU_HYPERBUS0_DQ6	1	IO								0		
		WKUP_GPIO0_25	7	IO								pad		
A7	MCU_OSPIO_D7	MCU_OSPIO_D7	0	IO	OFF	7	1.8 V/3.3 V	VDDSHV1_MCU	Yes	LVCMOS	PU/PD	0	1/0	
		MCU_HYPERBUS0_DQ7	1	IO								0		
		WKUP_GPIO0_26	7	IO								pad		
G19	MCU_PORz	MCU_PORz		I			1.8 V	VDDA_WKUP, VDDA_POR_WKUP	Yes	FS RESET				
B13	MCU_RESETSTATz	MCU_RESETSTATz	0	O	PD	0	1.8 V/3.3 V	VDDSHV0_MCU	Yes	LVCMOS	PU/PD			
		WKUP_GPIO0_79	7	IO								pad		
A18	MCU_RESETz	MCU_RESETz	0	I		0	1.8 V/3.3 V	VDDSHV0_MCU	Yes	LVCMOS	PU/PD			
B10	MCU_RGMII1_RXC	MCU_RGMII1_RXC	0	I	OFF	7	1.8 V/3.3 V	VDDSHV2_MCU	Yes	LVCMOS	PU/PD	0	1/0	
		MCU_RMII1_REF_CLK	1	I								0		
		WKUP_GPIO0_49	7	IO								pad		
A11	MCU_RGMII1_RX_CTL	MCU_RGMII1_RX_CTL	0	I	OFF	7	1.8 V/3.3 V	VDDSHV2_MCU	Yes	LVCMOS	PU/PD	0	1/0	
		MCU_RMII1_RX_ER	1	I								0		
		WKUP_GPIO0_43	7	IO								pad		
A12	MCU_RGMII1_TXC	MCU_RGMII1_TXC	0	O	OFF	7	1.8 V/3.3 V	VDDSHV2_MCU	Yes	LVCMOS	PU/PD		1/0	
		MCU_RMII1_TX_EN	1	O										
		WKUP_GPIO0_48	7	IO								pad		
D11	MCU_RGMII1_TX_CTL	MCU_RGMII1_TX_CTL	0	O	OFF	7	1.8 V/3.3 V	VDDSHV2_MCU	Yes	LVCMOS	PU/PD		1/0	
		MCU_RMII1_CRSDV	1	I								0		
		WKUP_GPIO0_29	7	IO								pad		
A9	MCU_RGMII1_RD0	MCU_RGMII1_RD0	0	I	OFF	7	1.8 V/3.3 V	VDDSHV2_MCU	Yes	LVCMOS	PU/PD	0	1/0	
		MCU_RMII1_RXD0	1	I								0		
		WKUP_GPIO0_53	7	IO								pad		
B9	MCU_RGMII1_RD1	MCU_RGMII1_RD1	0	I	OFF	7	1.8 V/3.3 V	VDDSHV2_MCU	Yes	LVCMOS	PU/PD	0	1/0	
		MCU_RMII1_RXD1	1	I								0		
		WKUP_GPIO0_52	7	IO								pad		
A10	MCU_RGMII1_RD2	MCU_RGMII1_RD2	0	I	OFF	7	1.8 V/3.3 V	VDDSHV2_MCU	Yes	LVCMOS	PU/PD	0	1/0	
		MCU_TIMER_IO5	1	IO								0		
		WKUP_GPIO0_51	7	IO								pad		
C10	MCU_RGMII1_RD3	MCU_RGMII1_RD3	0	I	OFF	7	1.8 V/3.3 V	VDDSHV2_MCU	Yes	LVCMOS	PU/PD	0	1/0	
		MCU_TIMER_IO4	1	IO								0		
		WKUP_GPIO0_50	7	IO								pad		

Table 6-1. Pin Attributes (continued)

BALL NUMBER [1]	BALL NAME [2]	SIGNAL NAME [3]	MUX MODE [4]	TYPE [5]	BALL RESET STATE [6]	BALL RESET REL. MUX MODE [7]	I/O VOLTAGE VALUE [8]	POWER [9]	HYS [10]	BUFFER TYPE [11]	PULL UP/DOWN TYPE [12]	DSIS [13]	RX ACTIVE/ TX DISABLE [14]	IO RET [15]	
D10	MCU_RGMII1_TD0	MCU_RGMII1_TD0	0	O	OFF	7	1.8 V/3.3 V	VDDSHV2_MCU	Yes	LVCMOS	PU/PD		1/0		
		MCU_RMII1_TXD0	1	O											
		WKUP_GPIO0_47	7	IO								pad			
B11	MCU_RGMII1_TD1	MCU_RGMII1_TD1	0	O	OFF	7	1.8 V/3.3 V	VDDSHV2_MCU	Yes	LVCMOS	PU/PD		1/0		
		MCU_RMII1_TXD1	1	O											
		WKUP_GPIO0_46	7	IO								pad			
B12	MCU_RGMII1_TD2	MCU_RGMII1_TD2	0	O	OFF	7	1.8 V/3.3 V	VDDSHV2_MCU	Yes	LVCMOS	PU/PD		1/0		
		MCU_TIMER_IO3	1	IO								0			
		MCU_ADC_EXT_TRIGGER1	3	I								0			
		WKUP_GPIO0_45	7	IO								pad			
C12	MCU_RGMII1_TD3	MCU_RGMII1_TD3	0	O	OFF	7	1.8 V/3.3 V	VDDSHV2_MCU	Yes	LVCMOS	PU/PD		1/0		
		MCU_TIMER_IO2	1	IO								0			
		MCU_ADC_EXT_TRIGGER0	3	I								0			
		WKUP_GPIO0_44	7	IO								pad			
G18	MCU_SAFETY_ERRORn	MCU_SAFETY_ERRORn	0	IO	OFF	0	1.8 V	VDDA_WKUP, VDDA_POR_WKUP	Yes	LVCMOS	PU/PD				
C13	MCU_SPI0_CLK	MCU_SPI0_CLK	0	IO	OFF	7	1.8 V/3.3 V	VDDSHV0_MCU	Yes	LVCMOS	PU/PD	0	1/0	Yes	
		WKUP_GPIO0_56	7	IO								pad			
		MCU_BOOTMODE00	Bootstrap	I											
A19	MCU_SPI0_CS0	MCU_SPI0_CS0	0	IO	OFF	7	1.8 V/3.3 V	VDDSHV0_MCU	Yes	LVCMOS	PU/PD	1	1/0	Yes	
		MCU_TIMER_IO1	4	IO								0			
		WKUP_GPIO0_59	7	IO								pad			
A20	MCU_SPI0_D0	MCU_SPI0_D0	0	IO	OFF	7	1.8 V/3.3 V	VDDSHV0_MCU	Yes	LVCMOS	PU/PD	0	1/0	Yes	
		WKUP_GPIO0_57	7	IO								pad			
		MCU_BOOTMODE01	Bootstrap	I											
B17	MCU_SPI0_D1	MCU_SPI0_D1	0	IO	OFF	7	1.8 V/3.3 V	VDDSHV0_MCU	Yes	LVCMOS	PU/PD	0	1/0	Yes	
		MCU_TIMER_IO0	4	IO								0			
		WKUP_GPIO0_58	7	IO								pad			
		MCU_BOOTMODE02	Bootstrap	I											
P20	MMC0_CALPAD	MMC0_CALPAD		A			1.8 V	VDDS_MMC0, VDDA_OP8_DLL_MM C0		eMMCPHY	PU/PD				
P18	MMC0_CLK	MMC0_CLK		O			1.8 V	VDDS_MMC0, VDDA_OP8_DLL_MM C0		eMMCPHY	PU/PD				
R17	MMC0_CMD	MMC0_CMD		IO			1.8 V	VDDS_MMC0, VDDA_OP8_DLL_MM C0		eMMCPHY	PU/PD	1			

Table 6-1. Pin Attributes (continued)

BALL NUMBER [1]	BALL NAME [2]	SIGNAL NAME [3]	MUX MODE [4]	TYPE [5]	BALL RESET STATE [6]	BALL RESET REL. MUX MODE [7]	I/O VOLTAGE VALUE [8]	POWER [9]	HYS [10]	BUFFER TYPE [11]	PULL UP/DOWN TYPE [12]	DSIS [13]	RX ACTIVE/ TX DISABLE [14]	IO RET [15]
P19	MMC0_DS	MMC0_DS		IO			1.8 V	VDDS_MMC0, VDDA_0P8_DLL_MM C0		eMMCPHY	PU/PD	1		
P21	MMC1_CLK	MMC1_CLK	0	IO	OFF	7	1.8 V/3.3 V	VDDSHV5	Yes	SDIO	PU/PD	0		
		UART8_RXD	1	I								1		
		TIMER_IO4	3	IO								0		
		UART4_CTSn	5	I								1		
		GPIO0_66	7	IO								pad		
		SPI1_CLK	8	IO								0		
		UART0_RTSn	9	O										
I2C6_SDA	10	IOD	1											
M20	MMC1_CMD	MMC1_CMD	0	IO	OFF	7	1.8 V/3.3 V	VDDSHV5	Yes	SDIO	PU/PD	1		
		UART8_TXD	1	O										
		TIMER_IO5	3	IO								0		
		UART4_RTSn	5	O										
		GPIO0_67	7	IO								pad		
		SPI1_D1	8	IO								0		
		I2C6_SCL	10	IOD								1		
R16	MMC0_DAT0	MMC0_DAT0		IO			1.8 V	VDDS_MMC0, VDDA_0P8_DLL_MM C0		eMMCPHY	PU/PD	1		
P17	MMC0_DAT1	MMC0_DAT1		IO			1.8 V	VDDS_MMC0, VDDA_0P8_DLL_MM C0		eMMCPHY	PU/PD	1		
R18	MMC0_DAT2	MMC0_DAT2		IO			1.8 V	VDDS_MMC0, VDDA_0P8_DLL_MM C0		eMMCPHY	PU/PD	1		
R20	MMC0_DAT3	MMC0_DAT3		IO			1.8 V	VDDS_MMC0, VDDA_0P8_DLL_MM C0		eMMCPHY	PU/PD	1		
R19	MMC0_DAT4	MMC0_DAT4		IO			1.8 V	VDDS_MMC0, VDDA_0P8_DLL_MM C0		eMMCPHY	PU/PD	1		
P16	MMC0_DAT5	MMC0_DAT5		IO			1.8 V	VDDS_MMC0, VDDA_0P8_DLL_MM C0		eMMCPHY	PU/PD	1		
R21	MMC0_DAT6	MMC0_DAT6		IO			1.8 V	VDDS_MMC0, VDDA_0P8_DLL_MM C0		eMMCPHY	PU/PD	1		
T21	MMC0_DAT7	MMC0_DAT7		IO			1.8 V	VDDS_MMC0, VDDA_0P8_DLL_MM C0		eMMCPHY	PU/PD	1		

Table 6-1. Pin Attributes (continued)

BALL NUMBER [1]	BALL NAME [2]	SIGNAL NAME [3]	MUX MODE [4]	TYPE [5]	BALL RESET STATE [6]	BALL RESET REL. MUX MODE [7]	I/O VOLTAGE VALUE [8]	POWER [9]	HYS [10]	BUFFER TYPE [11]	PULL UP/DOWN TYPE [12]	DSIS [13]	RX ACTIVE/ TX DISABLE [14]	IO RET [15]
M19	MMC1_DAT0	MMC1_DAT0	0	IO	OFF	7	1.8 V/3.3 V	VDDSHV5		SDIO	PU/PD	1		
		UART7_RTSn	1	O										
		ECAP1_IN_APWM_OUT	2	IO								IO		
		TIMER_IO3	3	IO								0		
		UART4_TXD	5	O										
		GPIO0_65	7	IO								pad		
		SPI1_D0	8	IO								0		
		UART5_RTSn	9	O										
		I2C4_SCL	10	IOD								1		
		UART2_TXD	11	O										
N21	MMC1_DAT1	MMC1_DAT1	0	IO	OFF	7	1.8 V/3.3 V	VDDSHV5		SDIO	PU/PD	1		
		UART7_CTSn	1	I								1		
		ECAP0_IN_APWM_OUT	2	IO								IO		
		TIMER_IO2	3	IO								0		
		UART4_RXD	5	I								1		
		GPIO0_64	7	IO								pad		
		SPI1_CS2	8	IO								1		
		UART5_CTSn	9	I								1		
		I2C4_SDA	10	IOD								1		
		UART2_RXD	11	I								1		
N20	MMC1_DAT2	MMC1_DAT2	0	IO	OFF	7	1.8 V/3.3 V	VDDSHV5		SDIO	PU/PD	1		
		UART7_TXD	1	O										
		TIMER_IO1	3	IO								0		
		GPIO0_63	7	IO								pad		
		SPI1_CS1	8	IO								1		
		CPTS0_TS_SYNC	9	O										
		I2C3_SDA	10	IOD								1		
		UART5_TXD	11	O										
N19	MMC1_DAT3	MMC1_DAT3	0	IO	OFF	7	1.8 V/3.3 V	VDDSHV5		SDIO	PU/PD	1		
		UART7_RXD	1	I								1		
		PCIE1_CLKREQn	2	IO								IO		
		TIMER_IO0	3	IO								0		
		GPIO0_62	7	IO								pad		
		SPI1_CS0	8	IO								1		
		UART0_CTSn	9	I								1		
		I2C3_SCL	10	IOD								1		
		UART5_RXD	11	I								1		

Table 6-1. Pin Attributes (continued)

BALL NUMBER [1]	BALL NAME [2]	SIGNAL NAME [3]	MUX MODE [4]	TYPE [5]	BALL RESET STATE [6]	BALL RESET REL. MUX MODE [7]	I/O VOLTAGE VALUE [8]	POWER [9]	HYS [10]	BUFFER TYPE [11]	PULL UP/DOWN TYPE [12]	DSIS [13]	RX ACTIVE/ TX DISABLE [14]	IO RET [15]
K19	OSC1_XI	OSC1_XI		I			1.8 V	VDDA_OSC1	Yes	HFOSC				
J19	OSC1_XO	OSC1_XO		O			1.8 V	VDDA_OSC1	Yes	HFOSC				
C15	PMIC_POWER_EN1	PMIC_POWER_EN1	0	O	OFF	7	1.8 V/3.3 V	VDDSHV0_MCU	Yes	LVCMOS	PU/PD			Yes
		MCU_I3C0_SDAPULLEN	5	OD										
		WKUP_GPIO0_68	7	IO								pad		
T19	PMIC_WAKE0n	PMIC_WAKE0n	0	OD	OFF	7	1.8 V/3.3 V	VDDSHV2	Yes	LVCMOS	PU/PD			
		RGMI4_TD1	4	O										
		GPIO0_1	7	IO								pad		
H20	PORz	PORz	0	I		0	1.8 V	VDDA_WKUP, VDDA_POR_WKUP	Yes	FS RESET				
U2	RESETSTATz	RESETSTATz	0	O	PD	0	1.8 V/3.3 V	VDDSHV0	Yes	LVCMOS	PU/PD			
A15	RESET_REQz	RESET_REQz	0	I	OFF	0	1.8 V/3.3 V	VDDSHV0_MCU	Yes	LVCMOS	PU/PD			
AA20	RMII1_CRSDV	RMII1_CRSDV	0	I	OFF	7	1.8 V/3.3 V	VDDSHV2	Yes	LVCMOS	PU/PD	0	1/0	Yes
		RGMI1_RD2	4	I								0		
		RMII1_CRSDV	5	I								0		
		GPIO0_4	7	IO								pad		
		EHRPWM2_B	9	IO								0		
		TRC_DATA7	10	O										
		UART4_TXD	11	O										
		MCASP1_AXR1	12	IO								0		
		GPMC0_AD2	14	IO								0		
Y17	RMII1_RX_ER	RMII1_RX_ER	0	I	OFF	7	1.8 V/3.3 V	VDDSHV2	Yes	LVCMOS	PU/PD	0	1/0	Yes
		RGMI1_RD3	4	I								0		
		RMII1_RX_ER	5	I								0		
		GPIO0_5	7	IO								pad		
		EHRPWM2_A	9	IO								0		
		TRC_DATA6	10	O										
		UART6_TXD	11	O										
		MCASP1_AXR0	12	IO								0		
		GPMC0_AD3	14	IO								0		

Table 6-1. Pin Attributes (continued)

BALL NUMBER [1]	BALL NAME [2]	SIGNAL NAME [3]	MUX MODE [4]	TYPE [5]	BALL RESET STATE [6]	BALL RESET REL. MUX MODE [7]	I/O VOLTAGE VALUE [8]	POWER [9]	HYS [10]	BUFFER TYPE [11]	PULL UP/DOWN TYPE [12]	DSIS [13]	RX ACTIVE/ TX DISABLE [14]	IO RET [15]
V17	RMII1_TX_EN	RMII1_TX_EN	0	O	OFF	7	1.8 V/3.3 V	VDDSHV2	Yes	LVCMOS	PU/PD		1/0	Yes
		RGMI14_RXC	4	I								0		
		RMII1_TX_EN	5	O										
		GPIO0_7	7	IO								pad		
		EQEP2_A	9	I								0		
		UART9_TXD	11	O										
		MCASP0_AXR8	12	IO								0		
		I2C1_SCL	13	IOD								1		
GPMC0_AD5	14	IO	0											
AA17	RMII1_RXD0	RMII1_RXD0	0	I	OFF	7	1.8 V/3.3 V	VDDSHV2	Yes	LVCMOS	PU/PD	0	1/0	Yes
		RGMI1_RD0	4	I								0		
		RMII1_RXD0	5	I								0		
		MCAN14_TX	6	O										
		GPIO0_2	7	IO								pad		
		TRC_DATA9	10	O										
		UART5_TXD	11	O										
		MCASP1_AXR3	12	IO								0		
GPMC0_AD0	14	IO	0											
Y15	RMII1_RXD1	RMII1_RXD1	0	I	OFF	7	1.8 V/3.3 V	VDDSHV2	Yes	LVCMOS	PU/PD	0	1/0	Yes
		RGMI1_RD1	4	I								0		
		RMII1_RXD1	5	I								0		
		MCAN14_RX	6	I								1		
		GPIO0_3	7	IO								pad		
		EHRPWM_TZn_IN2	9	I								0		
		TRC_DATA8	10	O										
		UART5_RXD	11	I								1		
		MCASP1_AXR2	12	IO								0		
		GPMC0_AD1	14	IO								0		
Y16	RMII1_TXD0	RMII1_TXD0	0	O	OFF	7	1.8 V/3.3 V	VDDSHV2	Yes	LVCMOS	PU/PD		1/0	Yes
		RGMI1_RX_CTL	4	I								0		
		RMII1_TXD0	5	O										
		GPIO0_6	7	IO								pad		
		EHRPWM0_SYNCO	9	O										
		TRC_CTL	10	O										
		UART6_RXD	11	I								1		
		MCASP0_AFSX	12	IO								0		
GPMC0_AD4	14	IO	0											

Table 6-1. Pin Attributes (continued)

BALL NUMBER [1]	BALL NAME [2]	SIGNAL NAME [3]	MUX MODE [4]	TYPE [5]	BALL RESET STATE [6]	BALL RESET REL. MUX MODE [7]	I/O VOLTAGE VALUE [8]	POWER [9]	HYS [10]	BUFFER TYPE [11]	PULL UP/DOWN TYPE [12]	DSIS [13]	RX ACTIVE/ TX DISABLE [14]	IO RET [15]	
AA19	RMII1_TXD1	RMII1_TXD1	0	O	OFF	7	1.8 V/3.3 V	VDDSHV2	Yes	LVCMOS	PU/PD		1/0	Yes	
		RGMI1_RXC	4	I								0			
		RMII1_TXD1	5	O											
		GPIO0_8	7	IO								pad			
		EHRPWM_TZn_IN1	9	I								0			
		TRC_DATA5	10	O											
		UART9_RXD	11	I								1			
		MCASP0_AXR3	12	IO								0			
		I2C1_SDA	13	IOD								1			
GPMC0_AD6	14	IO	0												
V7	SERDES0_REXT	SERDES0_REXT		A			0.8 V	VDDA_0P8_SERDES0 , VDDA_1P8_SERDES0 , VDDA_0P8_SERDES0 _C		SERDES					
AA8	SERDES0_REFCLK_N	SERDES0_REFCLK_N		IO			0.8 V	VDDA_0P8_SERDES0 , VDDA_1P8_SERDES0 , VDDA_0P8_SERDES0 _C		SERDES					
AA9	SERDES0_REFCLK_P	SERDES0_REFCLK_P		IO			0.8 V	VDDA_0P8_SERDES0 , VDDA_1P8_SERDES0 , VDDA_0P8_SERDES0 _C		SERDES					
AA11	SERDES0_RX0_N	SERDES0_RX0_N		I			0.8 V	VDDA_0P8_SERDES0 , VDDA_1P8_SERDES0 , VDDA_0P8_SERDES0 _C		SERDES					
		SGMII3_RX0_N		I											
		PCIE1_RX0_N		I											
		USB0_SSRX1N		I											
AA12	SERDES0_RX0_P	SERDES0_RX0_P		I			0.8 V	VDDA_0P8_SERDES0 , VDDA_1P8_SERDES0 , VDDA_0P8_SERDES0 _C		SERDES					
		SGMII3_RX0_P		I											
		PCIE1_RX0_P		I											
		USB0_SSRX1P		I											

Table 6-1. Pin Attributes (continued)

BALL NUMBER [1]	BALL NAME [2]	SIGNAL NAME [3]	MUX MODE [4]	TYPE [5]	BALL RESET STATE [6]	BALL RESET REL. MUX MODE [7]	I/O VOLTAGE VALUE [8]	POWER [9]	HYS [10]	BUFFER TYPE [11]	PULL UP/DOWN TYPE [12]	DSIS [13]	RX ACTIVE/ TX DISABLE [14]	IO RET [15]
W8	SERDES0_RX1_N	SERDES0_RX1_N		I			0.8 V	VDDA_0P8_SERDES0 , VDDA_1P8_SERDES0 , VDDA_0P8_SERDES0_C		SERDES				
		SGMII4_RX0_N		I										
		PCIE1_RX1_N		I										
		USB0_SSRX2N		I										
W9	SERDES0_RX1_P	SERDES0_RX1_P		I			0.8 V	VDDA_0P8_SERDES0 , VDDA_1P8_SERDES0 , VDDA_0P8_SERDES0_C		SERDES				
		SGMII4_RX0_P		I										
		PCIE1_RX1_P		I										
		USB0_SSRX2P		I										
Y7	SERDES0_RX2_N	SERDES0_RX2_N		I			0.8 V	VDDA_0P8_SERDES0 , VDDA_1P8_SERDES0 , VDDA_0P8_SERDES0_C		SERDES				
		SGMII1_RX0_N		I										
		PCIE1_RX2_N		I										
		USB0_SSRX1N		I										
Y8	SERDES0_RX2_P	SERDES0_RX2_P		I			0.8 V	VDDA_0P8_SERDES0 , VDDA_1P8_SERDES0 , VDDA_0P8_SERDES0_C		SERDES				
		SGMII1_RX0_P		I										
		PCIE1_RX2_P		I										
		USB0_SSRX1P		I										
W5	SERDES0_RX3_N	SERDES0_RX3_N		I			0.8 V	VDDA_0P8_SERDES0 , VDDA_1P8_SERDES0 , VDDA_0P8_SERDES0_C		SERDES				
		SGMII2_RX0_N		I										
		PCIE1_RX3_N		I										
		USB0_SSRX2N		I										

Table 6-1. Pin Attributes (continued)

BALL NUMBER [1]	BALL NAME [2]	SIGNAL NAME [3]	MUX MODE [4]	TYPE [5]	BALL RESET STATE [6]	BALL RESET REL. MUX MODE [7]	I/O VOLTAGE VALUE [8]	POWER [9]	HYS [10]	BUFFER TYPE [11]	PULL UP/DOWN TYPE [12]	DSIS [13]	RX ACTIVE/ TX DISABLE [14]	IO RET [15]
W6	SERDES0_RX3_P	SERDES0_RX3_P		I			0.8 V	VDDA_0P8_SERDES0 , VDDA_1P8_SERDES0 , VDDA_0P8_SERDES0_C		SERDES				
		SGMII2_RX0_P		I										
		PCIE1_RX3_P		I										
		USB0_SSRX2P		I										
W11	SERDES0_TX0_N	SERDES0_TX0_N		O			0.8 V	VDDA_0P8_SERDES0 , VDDA_1P8_SERDES0 , VDDA_0P8_SERDES0_C		SERDES				
		SGMII3_TX0_N		O										
		PCIE1_TX0_N		O										
		USB0_SSTX1N		O										
W12	SERDES0_TX0_P	SERDES0_TX0_P		O			0.8 V	VDDA_0P8_SERDES0 , VDDA_1P8_SERDES0 , VDDA_0P8_SERDES0_C		SERDES				
		SGMII3_TX0_P		O										
		PCIE1_TX0_P		O										
		USB0_SSTX1P		O										
Y10	SERDES0_TX1_N	SERDES0_TX1_N		O			0.8 V	VDDA_0P8_SERDES0 , VDDA_1P8_SERDES0 , VDDA_0P8_SERDES0_C		SERDES				
		SGMII4_TX0_N		O										
		PCIE1_TX1_N		O										
		USB0_SSTX2N		O										
Y11	SERDES0_TX1_P	SERDES0_TX1_P		O			0.8 V	VDDA_0P8_SERDES0 , VDDA_1P8_SERDES0 , VDDA_0P8_SERDES0_C		SERDES				
		SGMII4_TX0_P		O										
		PCIE1_TX1_P		O										
		USB0_SSTX2P		O										

Table 6-1. Pin Attributes (continued)

BALL NUMBER [1]	BALL NAME [2]	SIGNAL NAME [3]	MUX MODE [4]	TYPE [5]	BALL RESET STATE [6]	BALL RESET REL. MUX MODE [7]	I/O VOLTAGE VALUE [8]	POWER [9]	HYS [10]	BUFFER TYPE [11]	PULL UP/DOWN TYPE [12]	DSIS [13]	RX ACTIVE/ TX DISABLE [14]	IO RET [15]	
AA5	SERDES0_TX2_N	SERDES0_TX2_N		O			0.8 V	VDDA_0P8_SERDES0 , VDDA_1P8_SERDES0 , VDDA_0P8_SERDES0_C		SERDES					
		SGMII1_TX0_N		O											
		PCIE1_TX2_N		O											
		USB0_SSTX1N		O											
AA6	SERDES0_TX2_P	SERDES0_TX2_P		O			0.8 V	VDDA_0P8_SERDES0 , VDDA_1P8_SERDES0 , VDDA_0P8_SERDES0_C		SERDES					
		SGMII1_TX0_P		O											
		PCIE1_TX2_P		O											
		USB0_SSTX1P		O											
Y4	SERDES0_TX3_N	SERDES0_TX3_N		O			0.8 V	VDDA_0P8_SERDES0 , VDDA_1P8_SERDES0 , VDDA_0P8_SERDES0_C		SERDES					
		SGMII2_TX0_N		O											
		PCIE1_TX3_N		O											
		USB0_SSTX2N		O											
Y5	SERDES0_TX3_P	SERDES0_TX3_P		O			0.8 V	VDDA_0P8_SERDES0 , VDDA_1P8_SERDES0 , VDDA_0P8_SERDES0_C		SERDES					
		SGMII2_TX0_P		O											
		PCIE1_TX3_P		O											
		USB0_SSTX2P		O											
V2	SOC_SAFETY_ERRORn	SOC_SAFETY_ERRORn	0	IO	OFF	0	1.8 V/3.3 V	VDDSHV0	Yes	LVC MOS	PU/PD				
Y1	SPI0_CLK	SPI0_CLK	0	IO	OFF	7	1.8 V/3.3 V	VDDSHV0		Yes	PU/PD	0			
		UART1_CTSn	1	I				1							
		I2C2_SCL	2	IOD				IOD							
		GPIO0_53	7	IO				pad							
W3	SPI0_CS0	SPI0_CS0	0	IO	OFF	7	1.8 V/3.3 V	VDDSHV0		Yes	PU/PD	1			
		UART0_CTSn	2	I				I							
		GPIO0_51	7	IO				pad							

Table 6-1. Pin Attributes (continued)

BALL NUMBER [1]	BALL NAME [2]	SIGNAL NAME [3]	MUX MODE [4]	TYPE [5]	BALL RESET STATE [6]	BALL RESET REL. MUX MODE [7]	I/O VOLTAGE VALUE [8]	POWER [9]	HYS [10]	BUFFER TYPE [11]	PULL UP/DOWN TYPE [12]	DSIS [13]	RX ACTIVE/ TX DISABLE [14]	IO RET [15]
U5	SPI0_CS1	SPI0_CS1	0	IO	OFF	7	1.8 V/3.3 V	VDDSHV0	Yes	LVCMOS	PU/PD	1		
		CPTS0_TS_COMP	1	O										
		UART0_RTSn	2	O								O		
		GPIO0_52	7	IO								pad		
V4	SPI0_D0	SPI0_D0	0	IO	OFF	7	1.8 V/3.3 V	VDDSHV0	Yes	LVCMOS	PU/PD	0		
		UART1_RTSn	1	O										
		I2C2_SDA	2	IOD								IOD		
		GPIO0_54	7	IO								pad		
T5	SPI0_D1	SPI0_D1	0	IO	OFF	7	1.8 V/3.3 V	VDDSHV0	Yes	LVCMOS	PU/PD	0		
		GPIO0_55	7	IO								pad		
B15	TCK	TCK	0	I		0	1.8 V/3.3 V	VDDSHV0_MCU	Yes	LVCMOS	PU/PD			
F19	TDI	TDI	0	I	OFF	0	1.8 V/3.3 V	VDDSHV0_MCU	Yes	LVCMOS	PU/PD			
F21	TDO	TDO	0	OZ	OFF	0	1.8 V/3.3 V	VDDSHV0_MCU	Yes	LVCMOS	PU/PD			
V1	TIMER_IO0	TIMER_IO0	0	IO	OFF	7	1.8 V/3.3 V	VDDSHV0	Yes	LVCMOS	PU/PD	0		
		ECAP1_IN_APWM_OUT	1	IO								0		
		SYSCLKOUT0	2	O								O		
		UART3_CTSn	5	I								1		
		SPI7_D0	6	IO								0		
		GPIO0_60	7	IO								pad		
		MMC1_SDCD	8	I								1		
W1	TIMER_IO1	TIMER_IO1	0	IO	OFF	7	1.8 V/3.3 V	VDDSHV0	Yes	LVCMOS	PU/PD	0	0/0	
		ECAP2_IN_APWM_OUT	1	IO								0		
		OBSCLK0	2	O								O		
		UART3_RTSn	5	O										
		SPI7_D1	6	IO								0		
		GPIO0_61	7	IO								pad		
		MMC1_SDWP	8	I								1		
		PCIE1_CLKREQn	9	IO								0		
U4	TMS	TMS	0	I	OFF	0	1.8 V/3.3 V	VDDSHV0	Yes	LVCMOS	PU/PD			
B20	TRSTn	TRSTn	0	I		0	1.8 V/3.3 V	VDDSHV0_MCU	Yes	LVCMOS	PU/PD			
T16	UART0_RXD	UART0_RXD	0	I	OFF	7	1.8 V/3.3 V	VDDSHV2	Yes	LVCMOS	PU/PD	1	0/0	Yes
		RGMII4_TXC	4	O										
		GPIO0_47	7	IO								pad		
		GPMC0_WAIT0	14	I								0		

Table 6-1. Pin Attributes (continued)

BALL NUMBER [1]	BALL NAME [2]	SIGNAL NAME [3]	MUX MODE [4]	TYPE [5]	BALL RESET STATE [6]	BALL RESET REL. MUX MODE [7]	I/O VOLTAGE VALUE [8]	POWER [9]	HYS [10]	BUFFER TYPE [11]	PULL UP/DOWN TYPE [12]	DSIS [13]	RX ACTIVE/ TX DISABLE [14]	IO RET [15]
T17	UART0_TXD	UART0_TXD	0	O	OFF	7	1.8 V/3.3 V	VDDSHV2	Yes	LVCMOS	PU/PD			Yes
		RGMI14_TD2	4	O										
		GPIO0_48	7	IO								pad		
		GPMC0_WEn	14	O										
T18	UART1_RXD	UART1_RXD	0	I	OFF	7	1.8 V/3.3 V	VDDSHV2	Yes	LVCMOS	PU/PD	1		Yes
		MCAN17_TX	1	O										
		TIMER_IO6	3	IO								0		
		RGMI14_TD3	4	O										
		GPIO0_49	7	IO								pad		
		GPMC0_OEn_REn	14	O										
T20	UART1_TXD	UART1_TXD	0	O	OFF	7	1.8 V/3.3 V	VDDSHV2	Yes	LVCMOS	PU/PD			Yes
		MCAN17_RX	1	I								1		
		TIMER_IO7	3	IO								0		
		RGMI14_TX_CTL	4	O										
		GPIO0_50	7	IO								pad		
		GPMC0_CSn0	14	O										
V14	UART2_RXD	UART2_RXD	0	I	OFF	7	1.8 V/3.3 V	VDDSHV2	Yes	LVCMOS	PU/PD	1	0/0	Yes
		RGMI12_TD2	4	O										
		RMII2_CRD_DV	5	I								0		
		GPIO0_39	7	IO								pad		
		SPI6_CLK	8	IO								0		
		GPMC0_CLKOUT	9	O										
		GPMC0_FCLK_MUX	10	O										
		UART2_RXD	11	I								1		
		MCASP2_AXR3	12	IO								0		
		OBSCLK2	14	O										
V13	UART2_TXD	UART2_TXD	0	O	OFF	7	1.8 V/3.3 V	VDDSHV2	Yes	LVCMOS	PU/PD			Yes
		RGMI12_TD3	4	O										
		RMII2_RX_ER	5	I								0		
		GPIO0_40	7	IO								pad		
		SPI6_D0	8	IO								0		
		UART2_TXD	11	O										
		MCASP2_AFSX	12	IO								0		

Table 6-1. Pin Attributes (continued)

BALL NUMBER [1]	BALL NAME [2]	SIGNAL NAME [3]	MUX MODE [4]	TYPE [5]	BALL RESET STATE [6]	BALL RESET REL. MUX MODE [7]	I/O VOLTAGE VALUE [8]	POWER [9]	HYS [10]	BUFFER TYPE [11]	PULL UP/DOWN TYPE [12]	DSIS [13]	RX ACTIVE/ TX DISABLE [14]	IO RET [15]
W14	UART8_RXD	UART8_RXD	0	I	OFF	7	1.8 V/3.3 V	VDDSHV2		LVCMOS	PU/PD	1		Yes
		I2C4_SCL	2	IOD								IOD		
		MDIO0_MDIO	5	IO								0		
		GPIO0_42	7	IO								pad		
		TRC_DATA22	10	O										
		UART8_RXD	11	I								1		
		MCASP2_AFSR	12	IO								0		
		MCASP2_AXR4	13	IO								0		
W19	UART8_TXD	UART8_TXD	0	O	OFF	7	1.8 V/3.3 V	VDDSHV2		LVCMOS	PU/PD			Yes
		SPI1_CS3	1	IO								1		
		I2C4_SDA	2	IOD								IOD		
		MDIO0_MDC	5	O										
		GPIO0_43	7	IO								pad		
		TRC_DATA23	10	O										
		UART8_TXD	11	O										
		MCASP2_ACLKR	12	IO								0		
MCASP2_AXR5	13	IO	0											
AA3	USB0_DM	USB0_DM		IO			3.3 V	VDDA_0P8_USB ,VD DA_1P8_USB, VDDA_3P3_USB		USB2PHY				
AA2	USB0_DP	USB0_DP		IO			3.3 V	VDDA_0P8_USB ,VD DA_1P8_USB, VDDA_3P3_USB		USB2PHY				
T4	USB0_DRVVBUS	USB0_DRVVBUS	0	O	OFF	7	1.8 V/3.3 V	VDDSHV0	Yes	LVCMOS	PU/PD			
		GPIO0_68	7	IO								pad		
V6	USB0_ID	USB0_ID		A			3.3 V	VDDA_0P8_USB ,VD DA_1P8_USB, VDDA_3P3_USB		USB2PHY				
V5	USB0_RCALIB	USB0_RCALIB		IO			3.3 V	VDDA_0P8_USB ,VD DA_1P8_USB, VDDA_3P3_USB		USB2PHY				
Y2	USB0_VBUS	USB0_VBUS		A			5.0 V	VDDA_0P8_USB ,VD DA_1P8_USB, VDDA_3P3_USB		USB2PHY				
K14, P14	VDDAR_CORE	VDDAR_CORE		PWR										
J11, M10	VDDAR_CPU	VDDAR_CPU		PWR										
H12, J14	VDDAR_MCU	VDDAR_MCU		PWR										
K7	VDDA_0P8_PLL_DDR	VDDA_0P8_PLL_DDR		PWR										
P7	VDDA_0P8_USB	VDDA_0P8_USB		PWR										
M18	VDDA_0P8_DLL_MMC0	VDDA_0P8_DLL_MMC0		PWR										
R8, T7, U8	VDDA_0P8_SERDES0	VDDA_0P8_SERDES0		PWR										

Table 6-1. Pin Attributes (continued)

BALL NUMBER [1]	BALL NAME [2]	SIGNAL NAME [3]	MUX MODE [4]	TYPE [5]	BALL RESET STATE [6]	BALL RESET REL. MUX MODE [7]	I/O VOLTAGE VALUE [8]	POWER [9]	HYS [10]	BUFFER TYPE [11]	PULL UP/DOWN TYPE [12]	DSIS [13]	RX ACTIVE/ TX DISABLE [14]	IO RET [15]
R9	VDDA_0P8_SERDES0_C	VDDA_0P8_SERDES0_C		PWR										
R6	VDDA_1P8_USB	VDDA_1P8_USB		PWR										
P8	VDDA_1P8_SERDES0	VDDA_1P8_SERDES0		PWR										
R7	VDDA_3P3_USB	VDDA_3P3_USB		PWR										
J16	VDDA_ADC_MCU	VDDA_ADC_MCU		PWR										
F15	VDDA_MCU_PLLGRP0	VDDA_MCU_PLLGRP0		PWR										
F16	VDDA_MCU_TEMP	VDDA_MCU_TEMP		PWR										
G17	VDDA_OSC1	VDDA_OSC1		PWR										
N14	VDDA_PLLGRP0	VDDA_PLLGRP0		PWR										
N9	VDDA_PLLGRP4	VDDA_PLLGRP4		PWR										
J9	VDDA_PLLGRP6	VDDA_PLLGRP6		PWR										
L7	VDDA_PLLGRP8	VDDA_PLLGRP8		PWR										
J15	VDDA_POR_WKUP	VDDA_POR_WKUP		PWR										
J8	VDDA_TEMP0	VDDA_TEMP0		PWR										
P15	VDDA_TEMP1	VDDA_TEMP1		PWR										
H16	VDDA_WKUP	VDDA_WKUP		PWR										
N6, P6	VDDSHV0	VDDSHV0		PWR										
E13, E14, F13, F14	VDDSHV0_MCU	VDDSHV0_MCU		PWR										
E7, E8, F8	VDDSHV1_MCU	VDDSHV1_MCU		PWR										
T10, U11, U9	VDDSHV2	VDDSHV2		PWR										
F11, F12, G11	VDDSHV2_MCU	VDDSHV2_MCU		PWR										
K16, L16	VDDSHV5	VDDSHV5		PWR										
A1, G7, H6, J7, K6, M5, U1	VDDS_DDR	VDDS_DDR		PWR										
F7, L6	VDDS_DDR_BIAS	VDDS_DDR_BIAS		PWR										
J6	VDDS_DDR_C	VDDS_DDR_C		PWR										
M16, N16	VDDS_MMC0	VDDS_MMC0		PWR										
H8, K12, L13, M12, M14, N13, N15, N7, P10, P12, R11, R13, R15	VDD_CORE	VDD_CORE		PWR										
J10, L11, M9, N11, N8	VDD_CPU	VDD_CPU		PWR										
G9, H10, H14, J13, K15	VDD_MCU	VDD_MCU		PWR										
G13	VDD_MCU_WAKE1	VDD_MCU_WAKE1		PWR										
P11	VDD_WAKE0	VDD_WAKE0		PWR										
G15	VMON1_ER_VSYS	VMON1_ER_VSYS		PWR										

Table 6-1. Pin Attributes (continued)

BALL NUMBER [1]	BALL NAME [2]	SIGNAL NAME [3]	MUX MODE [4]	TYPE [5]	BALL RESET STATE [6]	BALL RESET REL. MUX MODE [7]	I/O VOLTAGE VALUE [8]	POWER [9]	HYS [10]	BUFFER TYPE [11]	PULL UP/DOWN TYPE [12]	DSIS [13]	RX ACTIVE/ TX DISABLE [14]	IO RET [15]
D16	VMON2_IR_VCPU	VMON2_IR_VCPU		PWR										
E17	VMON3_IR_VEXT1P8	VMON3_IR_VEXT1P8		PWR										
F17	VMON4_IR_VEXT1P8	VMON4_IR_VEXT1P8		PWR										
L14	VMON5_IR_VEXT3P3	VMON5_IR_VEXT3P3		PWR										
N17	VPP_CORE	VPP_CORE		PWR										
E11	VPP_MCU	VPP_MCU		PWR										
B5,AA1, AA10, AA13, AA4, AA7, C11, D15, D17, D3, E10, E12, E15, E16, E6, E9, F1, G10, G12, G16, G6, G8, H11, H13, H15, H19, H4, H7, H9, J1, J12, J21, K11, K13, K3, L12, L19, L5, M11, M13, M15, M21, M6, M8, N10, N12, N3, P13, P5, P9, R10, R12, R14, T11, T2, T6, T8, T9, U10, U7, V11, V12, V9, W10, W13, W18, W4, W7, Y12, Y3, Y6, Y9	VSS	VSS		GND										
B18	WKUP_GPIO0_0	MCU_SPI1_CLK	0	IO	OFF	7	1.8 V/3.3 V	VDDSHV0_MCU	Yes	LVCMOS	PU/PD	0		Yes
		MCU_SPI1_CLK	1	IO								0		
		WKUP_GPIO0_0	7	IO								pad		
		MCU_BOOTMODE03	Bootstrap	I										
B19	WKUP_GPIO0_1	MCU_SPI1_D0	0	IO	OFF	7	1.8 V/3.3 V	VDDSHV0_MCU	Yes	LVCMOS	PU/PD	0	1/0	Yes
		MCU_SPI1_D0	1	IO								0		
		WKUP_GPIO0_1	7	IO								pad		
		MCU_BOOTMODE04	Bootstrap	I										
D14	WKUP_GPIO0_2	MCU_SPI1_D1	0	IO	OFF	7	1.8 V/3.3 V	VDDSHV0_MCU	Yes	LVCMOS	PU/PD	0	1/0	Yes
		MCU_SPI1_D1	1	IO								0		
		WKUP_GPIO0_2	7	IO								pad		
		MCU_BOOTMODE05	Bootstrap	I										
B21	WKUP_GPIO0_3	MCU_SPI1_CS0	0	IO	OFF	7	1.8 V/3.3 V	VDDSHV0_MCU	Yes	LVCMOS	PU/PD	1		Yes
		MCU_SPI1_CS0	1	IO								1		
		WKUP_GPIO0_3	7	IO								pad		

Table 6-1. Pin Attributes (continued)

BALL NUMBER [1]	BALL NAME [2]	SIGNAL NAME [3]	MUX MODE [4]	TYPE [5]	BALL RESET STATE [6]	BALL RESET REL. MUX MODE [7]	I/O VOLTAGE VALUE [8]	POWER [9]	HYS [10]	BUFFER TYPE [11]	PULL UP/DOWN TYPE [12]	DSIS [13]	RX ACTIVE/ TX DISABLE [14]	IO RET [15]
D13	WKUP_GPIO0_4	MCU_MCAN1_TX	0	O	OFF	7	1.8 V/3.3 V	VDDSHV0_MCU	Yes	LVCMOS	PU/PD			Yes
		MCU_MCAN1_TX	1	O										
		MCU_SPI0_CS3	2	IO								IO		
		MCU_ADC_EXT_TRIGGER0	3	I								pad		
		WKUP_GPIO0_4	7	IO								pad		
B16	WKUP_GPIO0_5	MCU_MCAN1_RX	0	I	OFF	7	1.8 V/3.3 V	VDDSHV0_MCU	Yes	LVCMOS	PU/PD	1		Yes
		MCU_MCAN1_RX	1	I								1		
		MCU_SPH1_CS3	2	IO								IO		
		MCU_ADC_EXT_TRIGGER1	3	I								pad		
		WKUP_GPIO0_5	7	IO								pad		
C14	WKUP_GPIO0_6	WKUP_UART0_CTSn	0	I	OFF	7	1.8 V/3.3 V	VDDSHV0_MCU	Yes	LVCMOS	PU/PD	1		Yes
		WKUP_UART0_CTSn	1	I								1		
		MCU_CPTS0_HW1TSPUSH	2	I								I		
		MCU_I2C1_SCL	3	IOD								1		
		WKUP_GPIO0_6	7	IO								pad		
C18	WKUP_GPIO0_7	WKUP_UART0_RTSn	0	O	OFF	7	1.8 V/3.3 V	VDDSHV0_MCU	Yes	LVCMOS	PU/PD			Yes
		WKUP_UART0_RTSn	1	O										
		MCU_CPTS0_HW2TSPUSH	2	I								I		
		MCU_I2C1_SDA	3	IOD								1		
		WKUP_GPIO0_7	7	IO								pad		
C21	WKUP_GPIO0_8	MCU_I2C1_SCL	0	IOD	OFF	7	1.8 V/3.3 V	VDDSHV0_MCU	Yes	LVCMOS	PU/PD	1		Yes
		MCU_I2C1_SCL	1	IOD								1		
		MCU_CPTS0_TS_SYNC	2	O								O		
		MCU_I3C0_SCL	3	IO								1		
		MCU_TIMER_IO6	4	IO								0		
		WKUP_GPIO0_8	7	IO								pad		
C19	WKUP_GPIO0_9	MCU_I2C1_SDA	0	IOD	OFF	7	1.8 V/3.3 V	VDDSHV0_MCU	Yes	LVCMOS	PU/PD	1		Yes
		MCU_I2C1_SDA	1	IOD								1		
		MCU_CPTS0_TS_COMP	2	O								O		
		MCU_I3C0_SDA	3	IO								1		
		MCU_TIMER_IO7	4	IO								0		
		WKUP_GPIO0_9	7	IO								pad		

Table 6-1. Pin Attributes (continued)

BALL NUMBER [1]	BALL NAME [2]	SIGNAL NAME [3]	MUX MODE [4]	TYPE [5]	BALL RESET STATE [6]	BALL RESET REL. MUX MODE [7]	I/O VOLTAGE VALUE [8]	POWER [9]	HYS [10]	BUFFER TYPE [11]	PULL UP/DOWN TYPE [12]	DSIS [13]	RX ACTIVE/ TX DISABLE [14]	IO RET [15]
C20	WKUP_GPIO0_10	MCU_EXT_REFCLK0	0	I	OFF	7	1.8 V/3.3 V	VDDSHV0_MCU	Yes	LVCMOS	PU/PD	0		Yes
		MCU_EXT_REFCLK0	1	I								0		
		MCU_UART0_TXD	2	O								O		
		MCU_ADC_EXT_TRIGGER0	3	I								0		
		MCU_CPTS0_RFT_CLK	4	I								0		
		MCU_SYSCLKOUT0	5	O										
		WKUP_GPIO0_10	7	IO								pad		
C16	WKUP_GPIO0_11	MCU_OBSCLK0	0	O	OFF	7	1.8 V/3.3 V	VDDSHV0_MCU	Yes	LVCMOS	PU/PD			Yes
		MCU_OBSCLK0	1	O										
		MCU_UART0_RXD	2	I								I		
		MCU_ADC_EXT_TRIGGER1	3	I								0		
		MCU_TIMER_IO1	4	IO								0		
		MCU_I3C0_SDAPULLEN	5	OD										
		MCU_CLKOUT0	6	OZ										
WKUP_GPIO0_11	7	IO	pad											
D19	WKUP_GPIO0_12	MCU_UART0_TXD	0	O	OFF	7	1.8 V/3.3 V	VDDSHV0_MCU	Yes	LVCMOS	PU/PD			Yes
		MCU_SPI0_CS1	1	IO										
		WKUP_GPIO0_12	7	IO								pad		
		MCU_BOOTMODE08	Bootstrap	I										
D20	WKUP_GPIO0_13	MCU_UART0_RXD	0	I	OFF	7	1.8 V/3.3 V	VDDSHV0_MCU	Yes	LVCMOS	PU/PD	1		Yes
		MCU_SPI1_CS1	1	IO										
		WKUP_GPIO0_13	7	IO								pad		
		MCU_BOOTMODE09	Bootstrap	I										
E20	WKUP_GPIO0_14	MCU_UART0_CTSn	0	I	OFF	7	1.8 V/3.3 V	VDDSHV0_MCU	Yes	LVCMOS	PU/PD	1		Yes
		MCU_SPI0_CS2	1	IO										
		MCU_TIMER_IO8	4	IO								0		
		WKUP_GPIO0_14	7	IO								pad		
		MCU_BOOTMODE06	Bootstrap	I										
E21	WKUP_GPIO0_15	MCU_UART0_RTSn	0	O	OFF	7	1.8 V/3.3 V	VDDSHV0_MCU	Yes	LVCMOS	PU/PD			Yes
		MCU_SPI1_CS2	1	IO										
		MCU_TIMER_IO9	4	IO								0		
		WKUP_GPIO0_15	7	IO								pad		
		MCU_BOOTMODE07	Bootstrap	I										
D21	WKUP_GPIO0_77	MCU_TIMER_IO6	4	IO	OFF	7	1.8 V/3.3 V	VDDSHV0_MCU	Yes	LVCMOS	PU/PD	0		Yes
		WKUP_GPIO0_77	7	IO								pad		
		BOOTMODE04	Bootstrap	I										

Table 6-1. Pin Attributes (continued)

BALL NUMBER [1]	BALL NAME [2]	SIGNAL NAME [3]	MUX MODE [4]	TYPE [5]	BALL RESET STATE [6]	BALL RESET REL. MUX MODE [7]	I/O VOLTAGE VALUE [8]	POWER [9]	HYS [10]	BUFFER TYPE [11]	PULL UP/DOWN TYPE [12]	DSIS [13]	RX ACTIVE/ TX DISABLE [14]	IO RET [15]
E19	WKUP_GPIO0_78	MCU_TIMER_I07	4	IO	OFF	7	1.8 V/3.3 V	VDDSHV0_MCU	Yes	LVCMOS	PU/PD	0		Yes
		WKUP_GPIO0_78	7	IO								pad		
		BOOTMODE05	Bootstrap	I										
D18	WKUP_GPIO0_80	WKUP_GPIO0_80	7	IO	OFF	7	1.8 V/3.3 V	VDDSHV0_MCU	Yes	LVCMOS	PU/PD	pad		Yes
		BOOTMODE06	Bootstrap	I										
C17	WKUP_GPIO0_81	WKUP_LF_CLKIN	1	I	OFF	7	1.8 V/3.3 V	VDDSHV0_MCU	Yes	LVCMOS	PU/PD	pad		Yes
		WKUP_GPIO0_81	7	IO								pad		
		BOOTMODE07	Bootstrap	I										
E18	WKUP_GPIO0_84	PMIC_WAKE1n	0	OD	OFF	7	1.8 V/3.3 V	VDDSHV0_MCU	Yes	LVCMOS	PU/PD			
		MCU_EXT_REFCLK0	1	I								0		
		MCU_CPTS0_RFT_CLK	2	I								I		
		WKUP_GPIO0_84	7	IO								pad		
F20	WKUP_I2C0_SCL	WKUP_I2C0_SCL	0	IOD	OFF	0	1.8 V/3.3 V	VDDSHV0_MCU	Yes	I2C OD FS		1		Yes
		WKUP_GPIO0_64	7	IO								pad		
H21	WKUP_I2C0_SDA	WKUP_I2C0_SDA	0	IOD	OFF	0	1.8 V/3.3 V	VDDSHV0_MCU	Yes	I2C OD FS		1		Yes
		WKUP_GPIO0_65	7	IO								pad		
K21	WKUP_OSC0_XI	WKUP_OSC0_XI		I			1.8 V	VDDA_WKUP, VDDA_POR_WKUP	Yes	HFOSC				
L21	WKUP_OSC0_XO	WKUP_OSC0_XO		O			1.8 V	VDDA_WKUP, VDDA_POR_WKUP	Yes	HFOSC				
B14	WKUP_UART0_RXD	WKUP_UART0_RXD	0	I	OFF	7	1.8 V/3.3 V	VDDSHV0_MCU	Yes	LVCMOS	PU/PD	1	1/0	Yes
		WKUP_GPIO0_60	7	IO								pad		
A14	WKUP_UART0_TXD	WKUP_UART0_TXD	0	O	OFF	7	1.8 V/3.3 V	VDDSHV0_MCU	Yes	LVCMOS	PU/PD		1/0	Yes
		WKUP_GPIO0_61	7	IO								pad		

The following list describes the table column headers:

- BALL NUMBER:** Ball numbers on the bottom side associated with each signal on the bottom.
- BALL NAME:** Mechanical name from package device (name is taken from muxmode 0).
- SIGNAL NAME:** Names of signals multiplexed on each ball (also notice that the name of the ball is the signal name in muxmode 0).

Note

Table 6-1, *Pin Attributes*, does not take into account the subsystem multiplexing signals. Subsystem multiplexing signals are described in Section 6.3, *Signal Descriptions*.

- MUXMODE:** Multiplexing mode number:
 - MUXMODE 0 is the primary muxmode. The primary muxmode is not necessarily the default muxmode.

Note

The default muxmode is the mode at the release of the reset; also see the BALL RESET REL. MUXMODE column.

- b. MUXMODE 1 through 7 are possible muxmodes for alternate functions. On each pin, some muxmodes are effectively used for alternate functions, while some muxmodes are not used. Only MUXMODE values which correspond to defined functions should be used.
 - c. An empty box means Not Applicable.
5. **TYPE:** Signal type and direction:
- I = Input
 - O = Output
 - OD = Open drain terminal - Output
 - IO = Input or Output
 - IOD = Open drain terminal - Input or Output
 - IOZ = Input, Output or Three-state terminal
 - OZ = Output or Three-state terminal
 - A = Analog
 - PWR = Power
 - GND = Ground
 - CAP = LDO Capacitor.
6. **BALL RESET STATE:** The state of the terminal at power-on reset:
- DRIVE 0 (OFF): The buffer drives V_{OL} (pulldown or pullup resistor not activated).
 - DRIVE 1 (OFF): The buffer drives V_{OH} (pulldown or pullup resistor not activated).
 - OFF: High-impedance
 - PD: High-impedance with an active pulldown resistor
 - PU: High-impedance with an active pullup resistor
 - An empty box means Not Applicable.
7. **BALL RESET REL. MUXMODE:** This muxmode is automatically configured at the release of the RESETSTATz and MCU_RESETSTATz signals. An empty box means Not Applicable.
8. **I/O VOLTAGE VALUE:** This column describes the IO voltage value (the corresponding power supply). An empty box means Not Applicable.
9. **POWER:** The voltage supply that powers the terminal IO buffers. An empty box means Not Applicable.
10. **HYS:** Indicates if the input buffer has hysteresis:
- Yes: With hysteresis
 - No: Without hysteresis
- An empty box means No.
- For more information, see the hysteresis values in [Section 7.6, Electrical Characteristics](#).
11. **BUFFER TYPE:** This column describes the associated output buffer type
- An empty box means Not Applicable.

For drive strength of the associated output buffer, refer to [Section 7.6, Electrical Characteristics](#).

12. **PULL UP/DOWN TYPE:** Indicates the presence of an internal pullup or pulldown resistor. Pullup and pulldown resistors can be enabled or disabled via software.
- PU: Internal pullup
 - PD: Internal pulldown
 - PU/PD: Internal pullup and pulldown
 - An empty box means No pull.
13. **DSIS:** The deselected input state (DSIS) indicates the state driven on the peripheral input (logic "0", logic "1", or "pad" level) when the peripheral pin function is not selected by any of the PINCNTLx registers.
- 0: Logic 0 driven on the input signal port of the peripheral.
 - 1: Logic 1 driven on the input signal port of the peripheral.
 - pad: Logic state of the pad is driven on the input signal port of the peripheral.
 - An empty box means Not Applicable.
14. **RXACTIVE / TXDISABLE:** This column indicates the default value of the RXACTIVE / TXDISABLE bits in the PADCONFIG register.
- RXACTIVE: 0 = receiver disabled, 1 = receiver enabled.
 - TXDISABLE: 0 = driver enabled, 1 = driver disabled.
 - An empty box means Not Applicable.

Note

Configuring two pins to the same input signal is not supported as it can yield unexpected results. This can be easily prevented with the proper software configuration (HiZ mode is not an input signal).

Note

When a pad is set into a multiplexing mode which is not defined by pin multiplexing, that pad's behavior is undefined. This should be avoided.

15. **IO RET:** Indicates if wakeup and IO retention are supported.

6.3 Signal Descriptions

Many signals are available on multiple pins, according to the software configuration of the pin multiplexing options.

The following list describes the column headers:

1. **SIGNAL NAME:** The name of the signal passing through the pin.

Note

Signal names provided in each Signal Descriptions table, (Table 6-1 through Table 6-106) represent the pin layer multiplexed signal function which is selected via the PADCONFIG registers. Device subsystems may provide an additional layer of signal multiplexing, which means the signal names described in these tables may have additional signal functions. For more information, see the respective peripheral chapter of the device TRM.

2. **DESCRIPTION:** Description of the signal

3. **PIN TYPE:** Signal direction and type:

- I = Input
- O = Output
- OD = Opent drain terminal - Output
- IO = Input or Output
- IOD = Open drain terminal - Input or Output
- IOZ = Input, Output or Three-state terminal
- OZ = Output or Three-state terminal
- A = Analog
- PWR = Power
- GND = Ground
- CAP = LDO Capacitor

4. **BALL:** Associated balls bottom

For more information on the I/O cell configurations, see *Pad Configuration Registers* section in *Device Configuration* chapter of the device TRM.

6.3.1 ADC

Note

The ADC can be configured to be used as a GPI. For more information, see *Analog-to-Digital Converter (ADC)* section in *Peripherals* chapter in the device TRM.

6.3.1.1 MCU Domain

Table 6-2. ADC0 Signal Descriptions

SIGNAL NAME [1]	DESCRIPTION [2]	PIN TYPE [3]	BALL [4]
MCU_ADC0_AIN0	ADC Analog Input 0	A	H17
MCU_ADC0_AIN1	ADC Analog Input 1	A	K18
MCU_ADC0_AIN2	ADC Analog Input 2	A	M17
MCU_ADC0_AIN3	ADC Analog Input 3	A	L18
MCU_ADC0_AIN4	ADC Analog Input 4	A	J18
MCU_ADC0_AIN5	ADC Analog Input 5	A	J17
MCU_ADC0_AIN6	ADC Analog Input 6	A	K17
MCU_ADC0_AIN7	ADC Analog Input 7	A	L17
MCU_ADC_EXT_TRIGGER0	ADC Trigger Input	I	C12, C20, D13
MCU_ADC_EXT_TRIGGER1	ADC Trigger Input	I	B12, B16, C16

6.3.2 DDRSS

6.3.2.1 MAIN Domain

Table 6-3. DDRSS0 Signal Descriptions

SIGNAL NAME [1]	DESCRIPTION [2]	PIN TYPE [3]	BALL [4]
DDR_RET	External IO Retention Enable	I	R5
DDR0_CKN	DDRSS Differential Clock (negative)	IO	H1
DDR0_CKP	DDRSS Differential Clock (positive)	IO	G1
DDR0_RESETh	DDRSS Reset	IO	J5
DDR0_CA0	DDRSS Command Address	IO	G4
DDR0_CA1	DDRSS Command Address	IO	H3
DDR0_CA2	DDRSS Command Address	IO	J4
DDR0_CA3	DDRSS Command Address	IO	K1
DDR0_CA4	DDRSS Command Address	IO	J2
DDR0_CA5	DDRSS Command Address	IO	H5
DDR0_CAL0 ⁽¹⁾	IO Pad Calibration Resistor	A	K5
DDR0_CKE0	DDRSS Clock Enable	IO	G2
DDR0_CKE1	DDRSS Clock Enable	IO	H2
DDR0_CSn0_0	DDRSS Chip Select	IO	G3
DDR0_CSn0_1	DDRSS Chip Select	IO	K2
DDR0_CSn1_0	DDRSS Chip Select	IO	G5
DDR0_CSn1_1	DDRSS Chip Select	IO	J3
DDR0_DM0	DDRSS Data Mask	IO	A3
DDR0_DM1	DDRSS Data Mask	IO	E4
DDR0_DM2	DDRSS Data Mask	IO	N1
DDR0_DM3	DDRSS Data Mask	IO	R4
DDR0_DQ0	DDRSS Data	IO	B4
DDR0_DQ1	DDRSS Data	IO	A4
DDR0_DQ2	DDRSS Data	IO	C4
DDR0_DQ3	DDRSS Data	IO	C1
DDR0_DQ4	DDRSS Data	IO	C3
DDR0_DQ5	DDRSS Data	IO	C2
DDR0_DQ6	DDRSS Data	IO	A2
DDR0_DQ7	DDRSS Data	IO	B3
DDR0_DQ8	DDRSS Data	IO	D1
DDR0_DQ9	DDRSS Data	IO	D2
DDR0_DQ10	DDRSS Data	IO	F2
DDR0_DQ11	DDRSS Data	IO	E3
DDR0_DQ12	DDRSS Data	IO	F3
DDR0_DQ13	DDRSS Data	IO	F4
DDR0_DQ14	DDRSS Data	IO	D4
DDR0_DQ15	DDRSS Data	IO	F5
DDR0_DQ16	DDRSS Data	IO	K4
DDR0_DQ17	DDRSS Data	IO	L4
DDR0_DQ18	DDRSS Data	IO	M4
DDR0_DQ19	DDRSS Data	IO	L3
DDR0_DQ20	DDRSS Data	IO	L2

Table 6-3. DDRSS0 Signal Descriptions (continued)

SIGNAL NAME [1]	DESCRIPTION [2]	PIN TYPE [3]	BALL [4]
DDR0_DQ21	DDRSS Data	IO	L1
DDR0_DQ22	DDRSS Data	IO	M3
DDR0_DQ23	DDRSS Data	IO	N2
DDR0_DQ24	DDRSS Data	IO	R3
DDR0_DQ25	DDRSS Data	IO	T1
DDR0_DQ26	DDRSS Data	IO	P1
DDR0_DQ27	DDRSS Data	IO	P2
DDR0_DQ28	DDRSS Data	IO	N4
DDR0_DQ29	DDRSS Data	IO	P3
DDR0_DQ30	DDRSS Data	IO	P4
DDR0_DQ31	DDRSS Data	IO	N5
DDR0_QS0N	DDRSS Complimentary Data Strobe	IO	B1
DDR0_QS0P	DDRSS Data Strobe	IO	B2
DDR0_QS1N	DDRSS Complimentary Data Strobe	IO	E1
DDR0_QS1P	DDRSS Data Strobe	IO	E2
DDR0_QS2N	DDRSS Complimentary Data Strobe	IO	M1
DDR0_QS2P	DDRSS Data Strobe	IO	M2
DDR0_QS3N	DDRSS Complimentary Data Strobe	IO	R1
DDR0_QS3P	DDRSS Data Strobe	IO	R2

(1) An external 240 Ω ±1% resistor must be connected between this pin and VSS. No external voltage should be applied to this pin.

6.3.2.2 DDRSS Mapping

Table 6-4 presents DDRSS interface signal mapping.

Table 6-4. DDRSS Signal Mapping

SIGNAL NAME [1]	MEMORY TYPE	PIN TYPE [3]	BALL [4]
	LPDDR4		
DDR0_CA0	CA0_A	IO	G4
DDR0_CA1	CA1_A	IO	H3
DDR0_CA2	CA2_A	IO	J4
DDR0_CA3	CA3_A	IO	K1
DDR0_CA4	CA4_A	IO	J2
DDR0_CA5	CA5_A	IO	H5
DDR0_CKP	CK_t_A	IO	H1
DDR0_CKN	CK_c_A	IO	G1
DDR0_DQ0	DQ0	IO	B4
DDR0_DQ1	DQ1	IO	A4
DDR0_DQ2	DQ2	IO	C4
DDR0_DQ3	DQ3	IO	C1
DDR0_DQ4	DQ4	IO	C3
DDR0_DQ5	DQ5	IO	C2
DDR0_DQ6	DQ6	IO	A2
DDR0_DQ7	DQ7	IO	B3
DDR0_DQ8	DQ8	IO	D1
DDR0_DQ9	DQ9	IO	D2

Table 6-4. DDRSS Signal Mapping (continued)

SIGNAL NAME [1]	MEMORY TYPE	PIN TYPE [3]	BALL [4]
	LPDDR4		
DDR0_DQ10	DQ10	IO	F2
DDR0_DQ11	DQ11	IO	E3
DDR0_DQ12	DQ12	IO	F3
DDR0_DQ13	DQ13	IO	F4
DDR0_DQ14	DQ14	IO	D4
DDR0_DQ15	DQ15	IO	F5
DDR0_DQ16	DQ16	IO	K4
DDR0_DQ17	DQ17	IO	L4
DDR0_DQ18	DQ18	IO	M4
DDR0_DQ19	DQ19	IO	L3
DDR0_DQ20	DQ20	IO	L2
DDR0_DQ21	DQ21	IO	L1
DDR0_DQ22	DQ22	IO	M3
DDR0_DQ23	DQ23	IO	N2
DDR0_DQ24	DQ24	IO	R3
DDR0_DQ25	DQ25	IO	T1
DDR0_DQ26	DQ26	IO	P1
DDR0_DQ27	DQ27	IO	P2
DDR0_DQ28	DQ28	IO	N4
DDR0_DQ29	DQ29	IO	P3
DDR0_DQ30	DQ30	IO	P4
DDR0_DQ31	DQ31	IO	N5
DDR0_DM0	DMI0	IO	A3
DDR0_DM1	DMI1	IO	E4
DDR0_DM2	DMI2	IO	N1
DDR0_DM3	DMI3	IO	R4
DDR0_DQS0N	DQS0	IO	B1
DDR0_DQS0P	DQS0_n	IO	B2
DDR0_DQS1N	DQS1	IO	E1
DDR0_DQS1P	DQS1_n	IO	E2
DDR0_DQS2N	DQS2	IO	M1
DDR0_DQS2P	DQS2_n	IO	M2
DDR0_DQS3N	DQS3	IO	R1
DDR0_DQS3P	DQS3_n	IO	R2
DDR0_RESETn	RESET_n	IO	J5
DDR0_CAL0	VTP	A	K5
DDR0_CKE0		IO	G2
DDR0_CKE1		IO	H2
DDR0_CSn0_0		IO	G3
DDR0_CSn0_1		IO	K2
DDR0_CSn1_0		IO	G5
DDR0_CSn1_1		IO	J3

6.3.3 GPIO

6.3.3.1 MAIN Domain

Table 6-5. GPIO0 Signal Descriptions

SIGNAL NAME [1]	DESCRIPTION [2]	PIN TYPE [3]	BALL [4]
GPIO0_0	General Purpose Input/Output	IO	U6
GPIO0_1	General Purpose Input/Output	IO	T19
GPIO0_2	General Purpose Input/Output	IO	AA17
GPIO0_3	General Purpose Input/Output	IO	Y15
GPIO0_4	General Purpose Input/Output	IO	AA20
GPIO0_5	General Purpose Input/Output	IO	Y17
GPIO0_6	General Purpose Input/Output	IO	Y16
GPIO0_7	General Purpose Input/Output	IO	V17
GPIO0_8	General Purpose Input/Output	IO	AA19
GPIO0_9	General Purpose Input/Output	IO	V18
GPIO0_10	General Purpose Input/Output	IO	V20
GPIO0_11	General Purpose Input/Output	IO	W21
GPIO0_12	General Purpose Input/Output	IO	V16
GPIO0_13	General Purpose Input/Output	IO	Y18
GPIO0_14	General Purpose Input/Output	IO	Y19
GPIO0_15	General Purpose Input/Output	IO	Y21
GPIO0_16	General Purpose Input/Output	IO	W16
GPIO0_17	General Purpose Input/Output	IO	W15
GPIO0_18	General Purpose Input/Output	IO	Y20
GPIO0_19	General Purpose Input/Output	IO	V21
GPIO0_20	General Purpose Input/Output	IO	V19
GPIO0_21	General Purpose Input/Output	IO	T13
GPIO0_22	General Purpose Input/Output	IO	U14
GPIO0_23	General Purpose Input/Output	IO	U16
GPIO0_24	General Purpose Input/Output	IO	U15
GPIO0_25	General Purpose Input/Output	IO	T15
GPIO0_26	General Purpose Input/Output	IO	U19
GPIO0_27	General Purpose Input/Output	IO	T14
GPIO0_28	General Purpose Input/Output	IO	U18
GPIO0_29	General Purpose Input/Output	IO	U17
GPIO0_30	General Purpose Input/Output	IO	U20
GPIO0_31	General Purpose Input/Output	IO	Y14
GPIO0_32	General Purpose Input/Output	IO	Y13
GPIO0_33	General Purpose Input/Output	IO	AA15
GPIO0_34	General Purpose Input/Output	IO	AA14
GPIO0_35	General Purpose Input/Output	IO	AA18
GPIO0_36	General Purpose Input/Output	IO	AA16
GPIO0_37	General Purpose Input/Output	IO	W17
GPIO0_38	General Purpose Input/Output	IO	W20
GPIO0_39	General Purpose Input/Output	IO	V14
GPIO0_40	General Purpose Input/Output	IO	V13
GPIO0_41	General Purpose Input/Output	IO	U12

Table 6-5. GPIO0 Signal Descriptions (continued)

SIGNAL NAME [1]	DESCRIPTION [2]	PIN TYPE [3]	BALL [4]
GPIO0_42	General Purpose Input/Output	IO	W14
GPIO0_43	General Purpose Input/Output	IO	W19
GPIO0_44	General Purpose Input/Output	IO	U13
GPIO0_45	General Purpose Input/Output	IO	V15
GPIO0_46	General Purpose Input/Output	IO	U21
GPIO0_47	General Purpose Input/Output	IO	T16
GPIO0_48	General Purpose Input/Output	IO	T17
GPIO0_49	General Purpose Input/Output	IO	T18
GPIO0_50	General Purpose Input/Output	IO	T20
GPIO0_51	General Purpose Input/Output	IO	W3
GPIO0_52	General Purpose Input/Output	IO	U5
GPIO0_53	General Purpose Input/Output	IO	Y1
GPIO0_54	General Purpose Input/Output	IO	V4
GPIO0_55	General Purpose Input/Output	IO	T5
GPIO0_56	General Purpose Input/Output	IO	V3
GPIO0_57	General Purpose Input/Output	IO	W2
GPIO0_58	General Purpose Input/Output	IO	U3
GPIO0_59	General Purpose Input/Output	IO	T3
GPIO0_60	General Purpose Input/Output	IO	V1
GPIO0_61	General Purpose Input/Output	IO	W1
GPIO0_62	General Purpose Input/Output	IO	N19
GPIO0_63	General Purpose Input/Output	IO	N20
GPIO0_64	General Purpose Input/Output	IO	N21
GPIO0_65	General Purpose Input/Output	IO	M19
GPIO0_66	General Purpose Input/Output	IO	P21
GPIO0_67	General Purpose Input/Output	IO	M20
GPIO0_68	General Purpose Input/Output	IO	T4

6.3.3.2 WKUP Domain

Table 6-6. GPIO0 Signal Descriptions

SIGNAL NAME [1]	DESCRIPTION [2]	PIN TYPE [3]	ALF [4]
WKUP_GPIO0_0	General Purpose Input/Output	IO	B18
WKUP_GPIO0_1	General Purpose Input/Output	IO	B19
WKUP_GPIO0_2	General Purpose Input/Output	IO	D14
WKUP_GPIO0_3	General Purpose Input/Output	IO	B21
WKUP_GPIO0_4	General Purpose Input/Output	IO	D13
WKUP_GPIO0_5	General Purpose Input/Output	IO	B16
WKUP_GPIO0_6	General Purpose Input/Output	IO	C14
WKUP_GPIO0_7	General Purpose Input/Output	IO	C18
WKUP_GPIO0_8	General Purpose Input/Output	IO	C21
WKUP_GPIO0_9	General Purpose Input/Output	IO	C19
WKUP_GPIO0_10	General Purpose Input/Output	IO	C20
WKUP_GPIO0_11	General Purpose Input/Output	IO	C16
WKUP_GPIO0_12	General Purpose Input/Output	IO	D19

Table 6-6. GPIO0 Signal Descriptions (continued)

SIGNAL NAME [1]	DESCRIPTION [2]	PIN TYPE [3]	ALF [4]
WKUP_GPIO0_13	General Purpose Input/Output	IO	D20
WKUP_GPIO0_14	General Purpose Input/Output	IO	E20
WKUP_GPIO0_15	General Purpose Input/Output	IO	E21
WKUP_GPIO0_16	General Purpose Input/Output	IO	B6
WKUP_GPIO0_17	General Purpose Input/Output	IO	C8
WKUP_GPIO0_18	General Purpose Input/Output	IO	B7
WKUP_GPIO0_19	General Purpose Input/Output	IO	D8
WKUP_GPIO0_20	General Purpose Input/Output	IO	C7
WKUP_GPIO0_21	General Purpose Input/Output	IO	C5
WKUP_GPIO0_22	General Purpose Input/Output	IO	A5
WKUP_GPIO0_23	General Purpose Input/Output	IO	A6
WKUP_GPIO0_24	General Purpose Input/Output	IO	B8
WKUP_GPIO0_25	General Purpose Input/Output	IO	A8
WKUP_GPIO0_26	General Purpose Input/Output	IO	A7
WKUP_GPIO0_27	General Purpose Input/Output	IO	D6
WKUP_GPIO0_28	General Purpose Input/Output	IO	D7
WKUP_GPIO0_29	General Purpose Input/Output	IO	D11
WKUP_GPIO0_30	General Purpose Input/Output	IO	C6
WKUP_GPIO0_31	General Purpose Input/Output	IO	D5
WKUP_GPIO0_43	General Purpose Input/Output	IO	A11
WKUP_GPIO0_44	General Purpose Input/Output	IO	C12
WKUP_GPIO0_45	General Purpose Input/Output	IO	B12
WKUP_GPIO0_46	General Purpose Input/Output	IO	B11
WKUP_GPIO0_47	General Purpose Input/Output	IO	D10
WKUP_GPIO0_48	General Purpose Input/Output	IO	A12
WKUP_GPIO0_49	General Purpose Input/Output	IO	B10
WKUP_GPIO0_50	General Purpose Input/Output	IO	C10
WKUP_GPIO0_51	General Purpose Input/Output	IO	A10
WKUP_GPIO0_52	General Purpose Input/Output	IO	B9
WKUP_GPIO0_53	General Purpose Input/Output	IO	A9
WKUP_GPIO0_54	General Purpose Input/Output	IO	C9
WKUP_GPIO0_55	General Purpose Input/Output	IO	D9
WKUP_GPIO0_56	General Purpose Input/Output	IO	C13
WKUP_GPIO0_57	General Purpose Input/Output	IO	A20
WKUP_GPIO0_58	General Purpose Input/Output	IO	B17
WKUP_GPIO0_59	General Purpose Input/Output	IO	A19
WKUP_GPIO0_60	General Purpose Input/Output	IO	B14
WKUP_GPIO0_61	General Purpose Input/Output	IO	A14
WKUP_GPIO0_62	General Purpose Input/Output	IO	A16
WKUP_GPIO0_63	General Purpose Input/Output	IO	A17
WKUP_GPIO0_64	General Purpose Input/Output	IO	F20
WKUP_GPIO0_65	General Purpose Input/Output	IO	H21
WKUP_GPIO0_66	General Purpose Input/Output	IO	G21
WKUP_GPIO0_67	General Purpose Input/Output	IO	G20
WKUP_GPIO0_68	General Purpose Input/Output	IO	C15

Table 6-6. GPIO0 Signal Descriptions (continued)

SIGNAL NAME [1]	DESCRIPTION [2]	PIN TYPE [3]	ALF [4]
WKUP_GPIO0_77	General Purpose Input/Output	IO	D21
WKUP_GPIO0_78	General Purpose Input/Output	IO	E19
WKUP_GPIO0_79	General Purpose Input/Output	IO	B13
WKUP_GPIO0_80	General Purpose Input/Output	IO	D18
WKUP_GPIO0_81	General Purpose Input/Output	IO	C17
WKUP_GPIO0_84	General Purpose Input/Output	IO	E18

6.3.4 I2C

6.3.4.1 MAIN Domain

Table 6-7. I2C0 Signal Descriptions

SIGNAL NAME [1]	DESCRIPTION [2]	PIN TYPE [3]	BALL [4]
I2C0_SCL	I2C Clock	IOD	V3
I2C0_SDA	I2C Data	IOD	W2

Table 6-8. I2C1 Signal Descriptions

SIGNAL NAME [1]	DESCRIPTION [2]	PIN TYPE [3]	BALL [4]
I2C1_SCL	I2C Clock	IOD	U3, V17
I2C1_SDA	I2C Data	IOD	AA19, T3

Table 6-9. I2C2 Signal Descriptions

SIGNAL NAME [1]	DESCRIPTION [2]	PIN TYPE [3]	BALL [4]
I2C2_SCL	I2C Clock	IOD	W15, Y1
I2C2_SDA	I2C Data	IOD	V4, Y20

Table 6-10. I2C3 Signal Descriptions

SIGNAL NAME [1]	DESCRIPTION [2]	PIN TYPE [3]	BALL [4]
I2C3_SCL	I2C Clock	IOD	N19, V19
I2C3_SDA	I2C Data	IOD	N20, T13

Table 6-11. I2C4 Signal Descriptions

SIGNAL NAME [1]	DESCRIPTION [2]	PIN TYPE [3]	BALL [4]
I2C4_SCL	I2C Clock	IOD	M19, W14
I2C4_SDA	I2C Data	IOD	N21, W19

Table 6-12. I2C5 Signal Descriptions

SIGNAL NAME [1]	DESCRIPTION [2]	PIN TYPE [3]	BALL [4]
I2C5_SCL	I2C Clock	IOD	AA18
I2C5_SDA	I2C Data	IOD	AA16

Table 6-13. I2C6 Signal Descriptions

SIGNAL NAME [1]	DESCRIPTION [2]	PIN TYPE [3]	BALL [4]
I2C6_SCL	I2C Clock	IOD	AA15, M20

Table 6-13. I2C6 Signal Descriptions (continued)

SIGNAL NAME [1]	DESCRIPTION [2]	PIN TYPE [3]	BALL [4]
I2C6_SDA	I2C Data	IOD	AA14, P21

6.3.4.2 MCU Domain

Table 6-14. I2C0 Signal Descriptions

SIGNAL NAME [1]	DESCRIPTION [2]	PIN TYPE [3]	BALL [4]
MCU_I2C0_SCL	I2C Clock	IOD	G21
MCU_I2C0_SDA	I2C Data	IOD	G20

Table 6-15. I2C1 Signal Descriptions

SIGNAL NAME [1]	DESCRIPTION [2]	PIN TYPE [3]	BALL [4]
MCU_I2C1_SCL	I2C Clock	IOD	C14, C21
MCU_I2C1_SDA	I2C Data	IOD	C18, C19

6.3.4.3 WKUP Domain

Table 6-16. I2C0 Signal Descriptions

SIGNAL NAME [1]	DESCRIPTION [2]	PIN TYPE [3]	BALL [4]
WKUP_I2C0_SCL	I2C Clock	IOD	F20
WKUP_I2C0_SDA	I2C Data	IOD	H21

6.3.5 I3C

6.3.5.1 MAIN Domain

Table 6-17. I3C0 Signal Descriptions

SIGNAL NAME [1]	DESCRIPTION [2]	PIN TYPE [3]	BALL [4]
I3C0_SCL	I3C Clock	IO	AA18
I3C0_SDA	I3C Data	IO	AA16
I3C0_SDAPULLEN	MAIN domain I3C Data Pull Enable	O	AA14

6.3.5.2 MCU Domain

Table 6-18. I3C0 Signal Descriptions

SIGNAL NAME [1]	DESCRIPTION [2]	PIN TYPE [3]	BALL [4]
MCU_I3C0_SCL	I3C Clock	IO	C21
MCU_I3C0_SDA	I3C Data	IO	C19
MCU_I3C0_SDAPULLEN	MCU domain I3C Data Pull Enable	O	C15, C16

6.3.6 MCAN

6.3.6.1 MAIN Domain

Table 6-19. MCAN0 Signal Descriptions

SIGNAL NAME [1]	DESCRIPTION [2]	PIN TYPE [3]	BALL [4]
MCAN0_RX	MCAN Receive Data	I	V20
MCAN0_TX	MCAN Transmit Data	O	V18

Table 6-20. MCAN1 Signal Descriptions

SIGNAL NAME [1]	DESCRIPTION [2]	PIN TYPE [3]	BALL [4]
MCAN1_RX	MCAN Receive Data	I	V16
MCAN1_TX	MCAN Transmit Data	O	W21

Table 6-21. MCAN2 Signal Descriptions

SIGNAL NAME [1]	DESCRIPTION [2]	PIN TYPE [3]	BALL [4]
MCAN2_RX	MCAN Receive Data	I	Y19
MCAN2_TX	MCAN Transmit Data	O	Y18

Table 6-22. MCAN3 Signal Descriptions

SIGNAL NAME [1]	DESCRIPTION [2]	PIN TYPE [3]	BALL [4]
MCAN3_RX	MCAN Receive Data	I	W16
MCAN3_TX	MCAN Transmit Data	O	Y21

Table 6-23. MCAN4 Signal Descriptions

SIGNAL NAME [1]	DESCRIPTION [2]	PIN TYPE [3]	BALL [4]
MCAN4_RX	MCAN Receive Data	I	Y20
MCAN4_TX	MCAN Transmit Data	O	W15

Table 6-24. MCAN5 Signal Descriptions

SIGNAL NAME [1]	DESCRIPTION [2]	PIN TYPE [3]	BALL [4]
MCAN5_RX	MCAN Receive Data	I	V19
MCAN5_TX	MCAN Transmit Data	O	V21

Table 6-25. MCAN6 Signal Descriptions

SIGNAL NAME [1]	DESCRIPTION [2]	PIN TYPE [3]	BALL [4]
MCAN6_RX	MCAN Receive Data	I	U14
MCAN6_TX	MCAN Transmit Data	O	T13

Table 6-26. MCAN7 Signal Descriptions

SIGNAL NAME [1]	DESCRIPTION [2]	PIN TYPE [3]	BALL [4]
MCAN7_RX	MCAN Receive Data	I	U15
MCAN7_TX	MCAN Transmit Data	O	U16

Table 6-27. MCAN8 Signal Descriptions

SIGNAL NAME [1]	DESCRIPTION [2]	PIN TYPE [3]	BALL [4]
MCAN8_RX	MCAN Receive Data	I	U19
MCAN8_TX	MCAN Transmit Data	O	T15

Table 6-28. MCAN9 Signal Descriptions

SIGNAL NAME [1]	DESCRIPTION [2]	PIN TYPE [3]	BALL [4]
MCAN9_RX	MCAN Receive Data	I	U18
MCAN9_TX	MCAN Transmit Data	O	T14

Table 6-29. MCAN10 Signal Descriptions

SIGNAL NAME [1]	DESCRIPTION [2]	PIN TYPE [3]	BALL [4]
MCAN10_RX	MCAN Receive Data	I	U20
MCAN10_TX	MCAN Transmit Data	O	U17

Table 6-30. MCAN11 Signal Descriptions

SIGNAL NAME [1]	DESCRIPTION [2]	PIN TYPE [3]	BALL [4]
MCAN11_RX	MCAN Receive Data	I	Y13
MCAN11_TX	MCAN Transmit Data	O	Y14

Table 6-31. MCAN12 Signal Descriptions

SIGNAL NAME [1]	DESCRIPTION [2]	PIN TYPE [3]	BALL [4]
MCAN12_RX	MCAN Receive Data	I	AA14
MCAN12_TX	MCAN Transmit Data	O	AA15

Table 6-32. MCAN13 Signal Descriptions

SIGNAL NAME [1]	DESCRIPTION [2]	PIN TYPE [3]	BALL [4]
MCAN13_RX	MCAN Receive Data	I	AA16
MCAN13_TX	MCAN Transmit Data	O	AA18

Table 6-33. MCAN14 Signal Descriptions

SIGNAL NAME [1]	DESCRIPTION [2]	PIN TYPE [3]	BALL [4]
MCAN14_RX	MCAN Receive Data	I	Y15
MCAN14_TX	MCAN Transmit Data	O	AA17

Table 6-34. MCAN15 Signal Descriptions

SIGNAL NAME [1]	DESCRIPTION [2]	PIN TYPE [3]	BALL [4]
MCAN15_RX	MCAN Receive Data	I	W20
MCAN15_TX	MCAN Transmit Data	O	W17

Table 6-35. MCAN16 Signal Descriptions

SIGNAL NAME [1]	DESCRIPTION [2]	PIN TYPE [3]	BALL [4]
MCAN16_RX	MCAN Receive Data	I	U21
MCAN16_TX	MCAN Transmit Data	O	V15

Table 6-36. MCAN17 Signal Descriptions

SIGNAL NAME [1]	DESCRIPTION [2]	PIN TYPE [3]	BALL [4]
MCAN17_RX	MCAN Receive Data	I	T20
MCAN17_TX	MCAN Transmit Data	O	T18

6.3.6.2 MCU Domain

Table 6-37. MCAN0 Signal Descriptions

SIGNAL NAME [1]	DESCRIPTION [2]	PIN TYPE [3]	BALL [4]
MCU_MCAN0_RX	MCAN Receive Data	I	A17

Table 6-37. MCAN0 Signal Descriptions (continued)

SIGNAL NAME [1]	DESCRIPTION [2]	PIN TYPE [3]	BALL [4]
MCU_MCAN0_TX	MCAN Transmit Data	O	A16

Table 6-38. MCAN1 Signal Descriptions

SIGNAL NAME [1]	DESCRIPTION [2]	PIN TYPE [3]	BALL [4]
MCU_MCAN1_RX	MCAN Receive Data	I	B16
MCU_MCAN1_TX	MCAN Transmit Data	O	D13

6.3.7 MCSPI

6.3.7.1 MAIN Domain

Table 6-39. MCSPI0 Signal Descriptions

SIGNAL NAME [1]	DESCRIPTION [2]	PIN TYPE [3]	BALL [4]
SPI0_CLK	SPI Clock	IO	Y1
SPI0_CS0	SPI Chip Select 0	IO	W3
SPI0_CS1	SPI Chip Select 1	IO	U5
SPI0_CS2	SPI Chip Select 2	IO	Y14
SPI0_CS3	SPI Chip Select 3	IO	U13
SPI0_D0	SPI Data 0	IO	V4
SPI0_D1	SPI Data 1	IO	T5

Table 6-40. MCSPI1 Signal Descriptions

SIGNAL NAME [1]	DESCRIPTION [2]	PIN TYPE [3]	BALL [4]
SPI1_CLK	SPI Clock	IO	P21
SPI1_CS0	SPI Chip Select 0	IO	N19
SPI1_CS1	SPI Chip Select 1	IO	N20
SPI1_CS2	SPI Chip Select 2	IO	N21
SPI1_CS3	SPI Chip Select 3	IO	W19
SPI1_D0	SPI Data 0	IO	M19
SPI1_D1	SPI Data 1	IO	M20

Table 6-41. MCSPI2 Signal Descriptions

SIGNAL NAME [1]	DESCRIPTION [2]	PIN TYPE [3]	BALL [4]
SPI2_CLK	SPI Clock	IO	U20
SPI2_CS0	SPI Chip Select 0	IO	Y14
SPI2_CS1	SPI Chip Select 1	IO	Y13
SPI2_CS2	SPI Chip Select 2	IO	AA15
SPI2_CS3	SPI Chip Select 3	IO	AA14
SPI2_D0	SPI Data 0	IO	AA18
SPI2_D1	SPI Data 1	IO	AA16

Table 6-42. MCSPI3 Signal Descriptions

SIGNAL NAME [1]	DESCRIPTION [2]	PIN TYPE [3]	BALL [4]
SPI3_CLK	SPI Clock	IO	T14
SPI3_CS0	SPI Chip Select 0	IO	U16

Table 6-42. MCSPI3 Signal Descriptions (continued)

SIGNAL NAME [1]	DESCRIPTION [2]	PIN TYPE [3]	BALL [4]
SPI3_CS1	SPI Chip Select 1	IO	U15
SPI3_CS2	SPI Chip Select 2	IO	T15
SPI3_CS3	SPI Chip Select 3	IO	U19
SPI3_D0	SPI Data 0	IO	U18
SPI3_D1	SPI Data 1	IO	U17

Table 6-43. MCSPI5 Signal Descriptions

SIGNAL NAME [1]	DESCRIPTION [2]	PIN TYPE [3]	BALL [4]
SPI5_CLK	SPI Clock	IO	W15
SPI5_CS0	SPI Chip Select 0	IO	W16
SPI5_CS1	SPI Chip Select 1	IO	V21
SPI5_CS2	SPI Chip Select 2	IO	Y19
SPI5_CS3	SPI Chip Select 3	IO	Y18
SPI5_D0	SPI Data 0	IO	Y21
SPI5_D1	SPI Data 1	IO	Y20

Table 6-44. MCSPI6 Signal Descriptions

SIGNAL NAME [1]	DESCRIPTION [2]	PIN TYPE [3]	BALL [4]
SPI6_CLK	SPI Clock	IO	V14
SPI6_CS0	SPI Chip Select 0	IO	W21
SPI6_CS1	SPI Chip Select 1	IO	V16
SPI6_CS2	SPI Chip Select 2	IO	W17
SPI6_CS3	SPI Chip Select 3	IO	W20
SPI6_D0	SPI Data 0	IO	V13
SPI6_D1	SPI Data 1	IO	U12

Table 6-45. MCSPI7 Signal Descriptions

SIGNAL NAME [1]	DESCRIPTION [2]	PIN TYPE [3]	BALL [4]
SPI7_CLK	SPI Clock	IO	T3
SPI7_CS0	SPI Chip Select 0	IO	U3
SPI7_D0	SPI Data 0	IO	V1
SPI7_D1	SPI Data 1	IO	W1

6.3.7.2 MCU Domain**Table 6-46. MCSPI0 Signal Descriptions**

SIGNAL NAME [1]	DESCRIPTION [2]	PIN TYPE [3]	BALL [4]
MCU_SPI0_CLK	SPI Clock	IO	C13
MCU_SPI0_CS0	SPI Chip Select 0	IO	A19
MCU_SPI0_CS1	SPI Chip Select 1	IO	D19
MCU_SPI0_CS2	SPI Chip Select 2	IO	E20
MCU_SPI0_CS3	SPI Chip Select 3	IO	D13
MCU_SPI0_D0	SPI Data 0	IO	A20
MCU_SPI0_D1	SPI Data 1	IO	B17

Table 6-47. MCSPI1 Signal Descriptions

SIGNAL NAME [1]	DESCRIPTION [2]	PIN TYPE [3]	BALL [4]
MCU_SPI1_CLK	SPI Clock	IO	B18
MCU_SPI1_CS0	SPI Chip Select 0	IO	B21
MCU_SPI1_CS1	SPI Chip Select 1	IO	D20
MCU_SPI1_CS2	SPI Chip Select 2	IO	E21
MCU_SPI1_CS3	SPI Chip Select 3	IO	B16
MCU_SPI1_D0	SPI Data 0	IO	B19
MCU_SPI1_D1	SPI Data 1	IO	D14

6.3.8 UART

6.3.8.1 MAIN Domain

Table 6-48. UART0 Signal Descriptions

SIGNAL NAME [1]	DESCRIPTION [2]	PIN TYPE [3]	BALL [4]
UART0_CTSn	UART Clear to Send (active low)	I	N19, W3
UART0_DCDn	UART Data Carrier Detect (active low)	I	T15
UART0_DSRn	UART Data Set Ready (active low)	I	U19
UART0_DTRn	UART Data Terminal Ready (active low)	O	Y14
UART0_RIn	UART Ring Indicator	I	Y13
UART0_RTSn	UART Request to Send (active low)	O	P21, U5
UART0_RXD	UART Receive Data	I	T16
UART0_TXD	UART Transmit Data	O	T17

Table 6-49. UART1 Signal Descriptions

SIGNAL NAME [1]	DESCRIPTION [2]	PIN TYPE [3]	BALL [4]
UART1_CTSn	UART Clear to Send (active low)	I	Y1
UART1_RTSn	UART Request to Send (active low)	O	V4
UART1_RXD	UART Receive Data	I	T18
UART1_TXD	UART Transmit Data	O	T20

Table 6-50. UART2 Signal Descriptions

SIGNAL NAME [1]	DESCRIPTION [2]	PIN TYPE [3]	BALL [4]
UART2_CTSn	UART Clear to Send (active low)	I	U17
UART2_RTSn	UART Request to Send (active low)	O	U20
UART2_RXD	UART Receive Data	I	AA15, N21, V14
UART2_TXD	UART Transmit Data	O	AA14, M19, V13

Table 6-51. UART3 Signal Descriptions

SIGNAL NAME [1]	DESCRIPTION [2]	PIN TYPE [3]	BALL [4]
UART3_CTSn	UART Clear to Send (active low)	I	T15, V1
UART3_RTSn	UART Request to Send (active low)	O	U19, W1
UART3_RXD	UART Receive Data	I	U3, Y14, Y18
UART3_TXD	UART Transmit Data	O	T3, Y13, Y19

Table 6-52. UART4 Signal Descriptions

SIGNAL NAME [1]	DESCRIPTION [2]	PIN TYPE [3]	BALL [4]
UART4_CTSn	UART Clear to Send (active low)	I	P21
UART4_RTSn	UART Request to Send (active low)	O	M20
UART4_RXD	UART Receive Data	I	N21, U12
UART4_TXD	UART Transmit Data	O	AA20, M19

Table 6-53. UART5 Signal Descriptions

SIGNAL NAME [1]	DESCRIPTION [2]	PIN TYPE [3]	BALL [4]
UART5_CTSn	UART Clear to Send (active low)	I	N21
UART5_RTSn	UART Request to Send (active low)	O	M19
UART5_RXD	UART Receive Data	I	N19, Y15
UART5_TXD	UART Transmit Data	O	AA17, N20

Table 6-54. UART6 Signal Descriptions

SIGNAL NAME [1]	DESCRIPTION [2]	PIN TYPE [3]	BALL [4]
UART6_CTSn	UART Clear to Send (active low)	I	V16
UART6_RTSn	UART Request to Send (active low)	O	V21
UART6_RXD	UART Receive Data	I	Y16
UART6_TXD	UART Transmit Data	O	Y17

Table 6-55. UART7 Signal Descriptions

SIGNAL NAME [1]	DESCRIPTION [2]	PIN TYPE [3]	BALL [4]
UART7_CTSn	UART Clear to Send (active low)	I	N21
UART7_RTSn	UART Request to Send (active low)	O	M19
UART7_RXD	UART Receive Data	I	N19, U21
UART7_TXD	UART Transmit Data	O	N20, V15

Table 6-56. UART8 Signal Descriptions

SIGNAL NAME [1]	DESCRIPTION [2]	PIN TYPE [3]	BALL [4]
UART8_CTSn	UART Clear to Send (active low)	I	AA18
UART8_RTSn	UART Request to Send (active low)	O	AA16
UART8_RXD	UART Receive Data	I	P21, W14
UART8_TXD	UART Transmit Data	O	M20, W19

Table 6-57. UART9 Signal Descriptions

SIGNAL NAME [1]	DESCRIPTION [2]	PIN TYPE [3]	BALL [4]
UART9_CTSn	UART Clear to Send (active low)	I	Y18
UART9_RTSn	UART Request to Send (active low)	O	Y19
UART9_RXD	UART Receive Data	I	AA19, U13
UART9_TXD	UART Transmit Data	O	V17

6.3.8.2 MCU Domain

Table 6-58. UART0 Signal Descriptions

SIGNAL NAME [1]	DESCRIPTION [2]	PIN TYPE [3]	BALL [4]
MCU_UART0_CTSn	UART Clear to Send (active low)	I	E20
MCU_UART0_RTSn	UART Request to Send (active low)	O	E21
MCU_UART0_RXD	UART Receive Data	I	C16, D20
MCU_UART0_TXD	UART Transmit Data	O	C20, D19

6.3.8.3 WKUP Domain

Table 6-59. UART0 Signal Descriptions

SIGNAL NAME [1]	DESCRIPTION [2]	PIN TYPE [3]	BALL [4]
WKUP_UART0_CTSn	UART Clear to Send (active low)	I	C14
WKUP_UART0_RTSn	UART Request to Send (active low)	O	C18
WKUP_UART0_RXD	UART Receive Data	I	B14
WKUP_UART0_TXD	UART Transmit Data	O	A14

6.3.9 MDIO

6.3.9.1 MCU Domain

Table 6-60. MDIO0 Signal Descriptions

SIGNAL NAME [1]	DESCRIPTION [2]	PIN TYPE [3]	BALL [4]
MCU_MDIO0_MDC	MDIO Clock	O	D9
MCU_MDIO0_MDIO	MDIO Data	IO	C9

6.3.9.2 MAIN Domain

Table 6-61. MDIO0 Signal Descriptions

SIGNAL NAME [1]	DESCRIPTION [2]	PIN TYPE [3]	BALL [4]
MDIO0_MDC	MDIO Clock	O	W19
MDIO0_MDIO	MDIO Data	IO	W14

6.3.10 CPSW2G

6.3.10.1 MCU Domain

Table 6-62. CPSW2G0 Signal Descriptions

SIGNAL NAME [1]	DESCRIPTION [2]	PIN TYPE [3]	BALL [4]
MCU_RGMII1_RXC	RGMII Receive Clock	I	B10
MCU_RGMII1_TXC	RGMII Transmit Clock	O	A12
MCU_RGMII1_RX_CTL	RGMII Receive Control	I	A11
MCU_RGMII1_TX_CTL	RGMII Transmit Control	O	D11
MCU_RGMII1_RD0	RGMII Receive Data 0	I	A9
MCU_RGMII1_RD1	RGMII Receive Data 1	I	B9
MCU_RGMII1_RD2	RGMII Receive Data 2	I	A10
MCU_RGMII1_RD3	RGMII Receive Data 3	I	C10
MCU_RGMII1_TD0	RGMII Transmit Data 0	O	D10
MCU_RGMII1_TD1	RGMII Transmit Data 1	O	B11

Table 6-62. CPSW2G0 Signal Descriptions (continued)

SIGNAL NAME [1]	DESCRIPTION [2]	PIN TYPE [3]	BALL [4]
MCU_RGMII1_TD2	RGMII Transmit Data 2	O	B12
MCU_RGMII1_TD3	RGMII Transmit Data 3	O	C12
MCU_RMII1_CRS_DV	RMII Carrier Sense / Data Valid	I	D11
MCU_RMII1_REF_CLK	RMII Reference Clock	I	B10
MCU_RMII1_RX_ER	RMII Receive Data Error	I	A11
MCU_RMII1_TX_EN	RMII Transmit Enable	O	A12
MCU_RMII1_RXD0	RMII Receive Data 0	I	A9
MCU_RMII1_RXD1	RMII Receive Data 1	I	B9
MCU_RMII1_TXD0	RMII Transmit Data 0	O	D10
MCU_RMII1_TXD1	RMII Transmit Data 1	O	B11

6.3.11 CPSW5G**6.3.11.1 MAIN Domain****Table 6-63. CPSW5G0 Signal Descriptions**

SIGNAL NAME [1]	DESCRIPTION [2]	PIN TYPE [3]	BALL [4]
CLKOUT	RMII Clock Output (50 MHz). This pin is used for clock source to the external PHY and must be routed back to the RMII_REF_CLK pin for proper device operation.	OZ	U21
RGMII1_RXC	RGMII Receive Clock	I	AA19
RGMII1_TXC	RGMII Transmit Clock	O	Y20
RGMII1_RX_CTL	RGMII Receive Control	I	Y16
RGMII1_TX_CTL	RGMII Transmit Control	O	W15
RGMII1_RD0	RGMII Receive Data 0	I	AA17
RGMII1_RD1	RGMII Receive Data 1	I	Y15
RGMII1_RD2	RGMII Receive Data 2	I	AA20
RGMII1_RD3	RGMII Receive Data 3	I	Y17
RGMII1_TD0	RGMII Transmit Data 0	O	Y18
RGMII1_TD1	RGMII Transmit Data 1	O	Y19
RGMII1_TD2	RGMII Transmit Data 2	O	Y21
RGMII1_TD3	RGMII Transmit Data 3	O	W16
RGMII2_RXC	RGMII Receive Clock	I	Y14
RGMII2_TXC	RGMII Transmit Clock	O	W21
RGMII2_RX_CTL	RGMII Receive Control	I	AA16
RGMII2_TX_CTL	RGMII Transmit Control	O	U12
RGMII2_RD0	RGMII Receive Data 0	I	Y13
RGMII2_RD1	RGMII Receive Data 1	I	AA15
RGMII2_RD2	RGMII Receive Data 2	I	AA14
RGMII2_RD3	RGMII Receive Data 3	I	AA18
RGMII2_TD0	RGMII Transmit Data 0	O	W17
RGMII2_TD1	RGMII Transmit Data 1	O	W20
RGMII2_TD2	RGMII Transmit Data 2	O	V14
RGMII2_TD3	RGMII Transmit Data 3	O	V13
RGMII3_RXC	RGMII Receive Clock	I	V21
RGMII3_TXC	RGMII Transmit Clock	O	U20
RGMII3_RX_CTL	RGMII Receive Control	I	U15

Table 6-63. CPSW5G0 Signal Descriptions (continued)

SIGNAL NAME [1]	DESCRIPTION [2]	PIN TYPE [3]	BALL [4]
RGMI3_TX_CTL	RGMI3 Transmit Control	O	U17
RGMI3_RD0	RGMI3 Receive Data 0	I	V19
RGMI3_RD1	RGMI3 Receive Data 1	I	T13
RGMI3_RD2	RGMI3 Receive Data 2	I	U14
RGMI3_RD3	RGMI3 Receive Data 3	I	U16
RGMI3_TD0	RGMI3 Transmit Data 0	O	T15
RGMI3_TD1	RGMI3 Transmit Data 1	O	U19
RGMI3_TD2	RGMI3 Transmit Data 2	O	T14
RGMI3_TD3	RGMI3 Transmit Data 3	O	U18
RGMI4_RXC	RGMI4 Receive Clock	I	V17
RGMI4_TXC	RGMI4 Transmit Clock	O	T16
RGMI4_RX_CTL	RGMI4 Receive Control	I	V15
RGMI4_TX_CTL	RGMI4 Transmit Control	O	T20
RGMI4_RD0	RGMI4 Receive Data 0	I	V18
RGMI4_RD1	RGMI4 Receive Data 1	I	V20
RGMI4_RD2	RGMI4 Receive Data 2	I	V16
RGMI4_RD3	RGMI4 Receive Data 3	I	U13
RGMI4_TD0	RGMI4 Transmit Data 0	O	U21
RGMI4_TD1	RGMI4 Transmit Data 1	O	T19
RGMI4_TD2	RGMI4 Transmit Data 2	O	T17
RGMI4_TD3	RGMI4 Transmit Data 3	O	T18
RMII1_CRSDV	RMII1 Carrier Sense / Data Valid	I	AA20
RMII1_RX_ER	RMII1 Receive Data Error	I	Y17
RMII1_TX_EN	RMII1 Transmit Enable	O	V17
RMII1_RXD0	RMII1 Receive Data 0	I	AA17
RMII1_RXD1	RMII1 Receive Data 1	I	Y15
RMII1_TXD0	RMII1 Transmit Data 0	O	Y16
RMII1_TXD1	RMII1 Transmit Data 1	O	AA19
RMII2_CRSDV	RMII2 Carrier Sense / Data Valid	I	V14
RMII2_RX_ER	RMII2 Receive Data Error	I	V13
RMII2_TX_EN	RMII2 Transmit Enable	O	W21
RMII2_RXD0	RMII2 Receive Data 0	I	W17
RMII2_RXD1	RMII2 Receive Data 1	I	W20
RMII2_TXD0	RMII2 Transmit Data 0	O	U12
RMII2_TXD1	RMII2 Transmit Data 1	O	V16
RMII3_CRSDV	RMII3 Carrier Sense / Data Valid	I	U14
RMII3_RX_ER	RMII3 Receive Data Error	I	U16
RMII3_TX_EN	RMII3 Transmit Enable	O	T15
RMII3_RXD0	RMII3 Receive Data 0	I	V19
RMII3_RXD1	RMII3 Receive Data 1	I	T13
RMII3_TXD0	RMII3 Transmit Data 0	O	U15
RMII3_TXD1	RMII3 Transmit Data 1	O	U19
RMII4_CRSDV	RMII4 Carrier Sense / Data Valid	I	Y21
RMII4_RX_ER	RMII4 Receive Data Error	I	W16
RMII4_TX_EN	RMII4 Transmit Enable	O	Y20

Table 6-63. CPSW5G0 Signal Descriptions (continued)

SIGNAL NAME [1]	DESCRIPTION [2]	PIN TYPE [3]	BALL [4]
RMII4_RXD0	RMII Receive Data 0	I	Y18
RMII4_RXD1	RMII Receive Data 1	I	Y19
RMII4_TXD0	RMII Transmit Data 0	O	W15
RMII4_TXD1	RMII Transmit Data 1	O	V21
RMII_REF_CLK	RMII Reference Clock	I	V15

6.3.12 ECAP**6.3.12.1 MAIN Domain****Table 6-64. ECAP0 Signal Descriptions**

SIGNAL NAME [1]	DESCRIPTION [2]	PIN TYPE [3]	BALL [4]
ECAP0_IN_APWM_OUT	Enhanced Capture (ECAP) Input or Auxiliary PWM (APWM) Output	IO	N21, U3

Table 6-65. ECAP1 Signal Descriptions

SIGNAL NAME [1]	DESCRIPTION [2]	PIN TYPE [3]	BALL [4]
ECAP1_IN_APWM_OUT	Enhanced Capture (ECAP) Input or Auxiliary PWM (APWM) Output	IO	M19, V1

Table 6-66. ECAP2 Signal Descriptions

SIGNAL NAME [1]	DESCRIPTION [2]	PIN TYPE [3]	BALL [4]
ECAP2_IN_APWM_OUT	Enhanced Capture (ECAP) Input or Auxiliary PWM (APWM) Output	IO	W1

6.3.13 EQEP**6.3.13.1 MAIN Domain****Table 6-67. EQEP0 Signal Descriptions**

SIGNAL NAME [1]	DESCRIPTION [2]	PIN TYPE [3]	BALL [4]
EQEP0_A	EQEP Quadrature Input A	I	Y14
EQEP0_B	EQEP Quadrature Input B	I	Y13
EQEP0_I	EQEP Index	IO	AA16
EQEP0_S	EQEP Strobe	IO	AA18

Table 6-68. EQEP1 Signal Descriptions

SIGNAL NAME [1]	DESCRIPTION [2]	PIN TYPE [3]	BALL [4]
EQEP1_A	EQEP Quadrature Input A	I	AA15
EQEP1_B	EQEP Quadrature Input B	I	AA14
EQEP1_I	EQEP Index	IO	W20
EQEP1_S	EQEP Strobe	IO	W17

Table 6-69. EQEP2 Signal Descriptions

SIGNAL NAME [1]	DESCRIPTION [2]	PIN TYPE [3]	BALL [4]
EQEP2_A	EQEP Quadrature Input A	I	V17
EQEP2_B	EQEP Quadrature Input B	I	V18

Table 6-69. EQEP2 Signal Descriptions (continued)

SIGNAL NAME [1]	DESCRIPTION [2]	PIN TYPE [3]	BALL [4]
EQEP2_I	EQEP Index	IO	V16
EQEP2_S	EQEP Strobe	IO	V20

6.3.14 EPWM

6.3.14.1 MAIN Domain

Table 6-70. EPWM Signal Descriptions

SIGNAL NAME [1]	DESCRIPTION [2]	PIN TYPE [3]	BALL [4]
EHRPWM_SOCA	EHRPWM Start of Conversion A	O	W21
EHRPWM_SOCB	EHRPWM Start of Conversion B	O	U17

Table 6-71. EPWM0 Signal Descriptions

SIGNAL NAME [1]	DESCRIPTION [2]	PIN TYPE [3]	BALL [4]
EHRPWM0_A	EHRPWM Output A	IO	Y21
EHRPWM0_B	EHRPWM Output B	IO	Y19
EHRPWM0_SYNCI	Sync Input to EHRPWM module from an external pin	I	W15
EHRPWM0_SYNCO	Sync Output to EHRPWM module to an external pin	O	Y16
EHRPWM_TZn_IN0	EHRPWM Trip Zone Input 0 (active low)	I	W16

Table 6-72. EPWM1 Signal Descriptions

SIGNAL NAME [1]	DESCRIPTION [2]	PIN TYPE [3]	BALL [4]
EHRPWM1_A	EHRPWM Output A	IO	Y18
EHRPWM1_B	EHRPWM Output B	IO	Y20
EHRPWM_TZn_IN1	EHRPWM Trip Zone Input 1 (active low)	I	AA19

Table 6-73. EPWM2 Signal Descriptions

SIGNAL NAME [1]	DESCRIPTION [2]	PIN TYPE [3]	BALL [4]
EHRPWM2_A	EHRPWM Output A	IO	Y17
EHRPWM2_B	EHRPWM Output B	IO	AA20
EHRPWM_TZn_IN2	EHRPWM Trip Zone Input 2 (active low)	I	Y15

Table 6-74. EPWM3 Signal Descriptions

SIGNAL NAME [1]	DESCRIPTION [2]	PIN TYPE [3]	BALL [4]
EHRPWM3_A	EHRPWM Output A	IO	U15
EHRPWM3_B	EHRPWM Output B	IO	U18
EHRPWM3_SYNCI	Sync Input to EHRPWM module from an external pin	I	T14
EHRPWM3_SYNCO	Sync Output to EHRPWM module to an external pin	O	U19
EHRPWM_TZn_IN3	EHRPWM Trip Zone Input 3 (active low)	I	T15

Table 6-75. EPWM4 Signal Descriptions

SIGNAL NAME [1]	DESCRIPTION [2]	PIN TYPE [3]	BALL [4]
EHRPWM4_A	EHRPWM Output A	IO	U20
EHRPWM4_B	EHRPWM Output B	IO	V21

Table 6-75. EPWM4 Signal Descriptions (continued)

SIGNAL NAME [1]	DESCRIPTION [2]	PIN TYPE [3]	BALL [4]
EHRPWM_TZn_IN4	EHRPWM Trip Zone Input 4 (active low)	I	U16

Table 6-76. EPWM5 Signal Descriptions

SIGNAL NAME [1]	DESCRIPTION [2]	PIN TYPE [3]	BALL [4]
EHRPWM5_A	EHRPWM Output A	IO	U14
EHRPWM5_B	EHRPWM Output B	IO	T13
EHRPWM_TZn_IN5	EHRPWM Trip Zone Input 5 (active low)	I	V19

6.3.15 USB

6.3.15.1 MAIN Domain

Note

USB3 functionality is available on the SERDES pins. For more information, refer to [Section 6.3.16, SERDES](#).

Table 6-77. USB0 Signal Descriptions

SIGNAL NAME [1]	DESCRIPTION [2]	PIN TYPE [3]	BALL [4]
USB0_DM	USB 2.0 Differential Data (negative)	IO	AA3
USB0_DP	USB 2.0 Differential Data (positive)	IO	AA2
USB0_DRVVBUS	USB VBUS control output (active high)	O	T4, U13
USB0_ID	USB 2.0 Dual-Role Device Role Select	A	V6
USB0_RCALIB ⁽²⁾	Pin to connect to calibration resistor	IO	V5
USB0_VBUS ⁽¹⁾	USB Level-shifted VBUS Input	A	Y2

(1) An external resistor divider is required to limit the voltage applied to the device pin. For more information, see [Section 9.3.3, USB Design Guidelines](#).

(2) An external 500 Ω ±1% resistor must be connected between this pin and VSS, even when the pin is unused.

6.3.16 SERDES

Note

The functionality of these pins is controlled by SERDES0_LN[4:0]_CTRL_LANE_FUNC_SEL.

6.3.16.1 MAIN Domain

Table 6-78. SERDES0 Lane0 Signal Descriptions

SIGNAL NAME [1]	DESCRIPTION [2]	PIN TYPE [3]	BALL [4]
SERDES0_RX0_N	SERDES Differential Receive Data (negative)	I	AA11
SERDES0_RX0_P	SERDES Differential Receive Data (positive)	I	AA12
SERDES0_TX0_N	SERDES Differential Transmit Data (negative)	O	W11
SERDES0_TX0_P	SERDES Differential Transmit Data (positive)	O	W12

Table 6-79. SERDES0 Lane1 Signal Descriptions

SIGNAL NAME [1]	DESCRIPTION [2]	PIN TYPE [3]	BALL [4]
SERDES0_RX1_N	SERDES Differential Receive Data (negative)	I	W8
SERDES0_RX1_P	SERDES Differential Receive Data (positive)	I	W9
SERDES0_TX1_N	SERDES Differential Transmit Data (negative)	O	Y10

Table 6-79. SERDES0 Lane1 Signal Descriptions (continued)

SIGNAL NAME [1]	DESCRIPTION [2]	PIN TYPE [3]	BALL [4]
SERDES0_TX1_P	SERDES Differential Transmit Data (positive)	O	Y11

Table 6-80. SERDES0 Lane2 Signal Descriptions

SIGNAL NAME [1]	DESCRIPTION [2]	PIN TYPE [3]	BALL [4]
SERDES0_RX2_N	SERDES Differential Receive Data (negative)	I	Y7
SERDES0_RX2_P	SERDES Differential Receive Data (positive)	I	Y8
SERDES0_TX2_N	SERDES Differential Transmit Data (negative)	O	AA5
SERDES0_TX2_P	SERDES Differential Transmit Data (positive)	O	AA6

Table 6-81. SERDES0 Lane3 Signal Descriptions

SIGNAL NAME [1]	DESCRIPTION [2]	PIN TYPE [3]	BALL [4]
SERDES0_RX3_N	SERDES Differential Receive Data (negative)	I	W5
SERDES0_RX3_P	SERDES Differential Receive Data (positive)	I	W6
SERDES0_TX3_N	SERDES Differential Transmit Data (negative)	O	Y4
SERDES0_TX3_P	SERDES Differential Transmit Data (positive)	O	Y5

Table 6-82. SERDES0 Signal Descriptions

SIGNAL NAME [1]	DESCRIPTION [2]	PIN TYPE [3]	BALL [4]
PCIE1_CLKREQn	PCIE Clock Request Signal	IO	N19, W1
SERDES0_REXT ⁽¹⁾	External Calibration Resistor	A	V7
SERDES0_REFCLK_N	Serdes Reference Clock Input/Output (negative)	IO	AA8
SERDES0_REFCLK_P	Serdes Reference Clock Input/Output (positive)	IO	AA9

(1) An external 3.01 kΩ ±1% resistor must be connected between this pin and VSS. No external voltage should be applied to this pin.

6.3.17 OSPI

6.3.17.1 MCU Domain

Table 6-83. OSPI0 Signal Descriptions

SIGNAL NAME [1]	DESCRIPTION [2]	PIN TYPE [3]	BALL [4]
MCU_OSPI0_CLK	OSPI Clock	O	B6
MCU_OSPI0_DQS	OSPI Data Strobe (DQS) or Loopback Clock Input	I	B7
MCU_OSPI0_ECC_FAIL	OSPI ECC Status	I	D5
MCU_OSPI0_LBCLKO	OSPI Loopback Clock Output	IO	C8
MCU_OSPI0_CSn0	OSPI Chip Select 0 (active low)	O	D6
MCU_OSPI0_CSn1	OSPI Chip Select 1 (active low)	O	D7
MCU_OSPI0_CSn2	OSPI Chip Select 2 (active low)	O	C6
MCU_OSPI0_CSn3	OSPI Chip Select 3 (active low)	O	D5
MCU_OSPI0_D0	OSPI Data 0	IO	D8
MCU_OSPI0_D1	OSPI Data 1	IO	C7
MCU_OSPI0_D2	OSPI Data 2	IO	C5
MCU_OSPI0_D3	OSPI Data 3	IO	A5
MCU_OSPI0_D4	OSPI Data 4	IO	A6
MCU_OSPI0_D5	OSPI Data 5	IO	B8
MCU_OSPI0_D6	OSPI Data 6	IO	A8
MCU_OSPI0_D7	OSPI Data 7	IO	A7

Table 6-83. OSPI0 Signal Descriptions (continued)

SIGNAL NAME [1]	DESCRIPTION [2]	PIN TYPE [3]	BALL [4]
MCU_OSPI0_RESET_OUT0	OSPI Reset	O	C6
MCU_OSPI0_RESET_OUT1	OSPI Reset	O	D5

6.3.18 Hyperbus

6.3.18.1 MCU Domain

Table 6-84. HYPERBUS0 Signal Descriptions

SIGNAL NAME [1]	DESCRIPTION [2]	PIN TYPE [3]	BALL [4]
MCU_HYPERBUS0_CK	Hyperbus Differential Clock (positive)	O	B6
MCU_HYPERBUS0_CKn	Hyperbus Differential Clock (negative)	O	C8
MCU_HYPERBUS0_INTn	Hyperbus Interrupt (active low)	I	D5
MCU_HYPERBUS0_RESETn	Hyperbus Reset (active low) Output	O	D7
MCU_HYPERBUS0_RESETOn	Hyperbus Reset Status Indicator (active low) from Hyperbus Memory	I	C6
MCU_HYPERBUS0_RWDS	Hyperbus Read-Write Data Strobe	IO	B7
MCU_HYPERBUS0_WPn	Hyperbus Write Protect (Not in use)	O	C6, D5
MCU_HYPERBUS0_CSn0	Hyperbus Chip Select 0	O	D6
MCU_HYPERBUS0_CSn1	Hyperbus Chip Select 1	O	C6
MCU_HYPERBUS0_DQ0	Hyperbus Data 0	IO	D8
MCU_HYPERBUS0_DQ1	Hyperbus Data 1	IO	C7
MCU_HYPERBUS0_DQ2	Hyperbus Data 2	IO	C5
MCU_HYPERBUS0_DQ3	Hyperbus Data 3	IO	A5
MCU_HYPERBUS0_DQ4	Hyperbus Data 4	IO	A6
MCU_HYPERBUS0_DQ5	Hyperbus Data 5	IO	B8
MCU_HYPERBUS0_DQ6	Hyperbus Data 6	IO	A8
MCU_HYPERBUS0_DQ7	Hyperbus Data 7	IO	A7

6.3.19 GPMC

6.3.19.1 MAIN Domain

Table 6-85. GPMC0 Signal Descriptions

SIGNAL NAME [1]	DESCRIPTION [2]	PIN TYPE [3]	BALL [4]
GPMC0_CLK	GPMC clock	IO	U13
GPMC0_ADVn_ALE	GPMC Address Valid (active low) or Address Latch Enable	O	W20
GPMC0_CLKOUT	GPMC clock generated for external synchronization	O	V14
GPMC0_DIR	GPMC Data Bus Signal Direction Control	O	V21
GPMC0_OEn_REn	GPMC Output Enable (active low) or Read Enable (active low)	O	T18
GPMC0_WEn	GPMC Write Enable (active low)	O	T17
GPMC0_WPn	GPMC Flash Write Protect (active low)	O	AA18
GPMC0_A0	GPMC Address 0 Output. Only used to effectively address 8-bit data non-multiplexed memories	OZ	W17
GPMC0_A1	GPMC address 1 Output in A/D non-multiplexed mode and Address 17 in A/D multiplexed mode	OZ	V18
GPMC0_A2	GPMC address 2 Output in A/D non-multiplexed mode and Address 18 in A/D multiplexed mode	OZ	V20

Table 6-85. GPMC0 Signal Descriptions (continued)

SIGNAL NAME [1]	DESCRIPTION [2]	PIN TYPE [3]	BALL [4]
GPMC0_A3	GPMC address 3 Output in A/D non-multiplexed mode and Address 19 in A/D multiplexed mode	OZ	W21
GPMC0_A4	GPMC address 4 Output in A/D non-multiplexed mode and Address 20 in A/D multiplexed mode	OZ	W16
GPMC0_A5	GPMC address 5 Output in A/D non-multiplexed mode and Address 21 in A/D multiplexed mode	OZ	V19
GPMC0_A6	GPMC address 6 Output in A/D non-multiplexed mode and Address 22 in A/D multiplexed mode	OZ	T13
GPMC0_A7	GPMC address 7 Output in A/D non-multiplexed mode and Address 23 in A/D multiplexed mode	OZ	T15
GPMC0_A8	GPMC address 8 Output in A/D non-multiplexed mode and Address 24 in A/D multiplexed mode	OZ	U19
GPMC0_A9	GPMC address 9 Output in A/D non-multiplexed mode and Address 25 in A/D multiplexed mode	OZ	T14
GPMC0_A10	GPMC address 10 Output in A/D non-multiplexed mode and Address 26 in A/D multiplexed mode	OZ	U18
GPMC0_A11	GPMC address 11 Output in A/D non-multiplexed mode and unused in A/D multiplexed mode	OZ	Y14
GPMC0_A12	GPMC address 12 Output in A/D non-multiplexed mode and unused in A/D multiplexed mode	OZ	Y13
GPMC0_A13	GPMC address 13 Output in A/D non-multiplexed mode and unused in A/D multiplexed mode	OZ	U12
GPMC0_A14	GPMC address 14 Output in A/D non-multiplexed mode and unused in A/D multiplexed mode	OZ	V15
GPMC0_A15	GPMC address 15 Output in A/D non-multiplexed mode and unused in A/D multiplexed mode	OZ	W20
GPMC0_A16	GPMC address 16 Output in A/D non-multiplexed mode and unused in A/D multiplexed mode	OZ	U20
GPMC0_A17	GPMC address 17 Output in A/D non-multiplexed mode and unused in A/D multiplexed mode	OZ	AA15
GPMC0_A18	GPMC address 18 Output in A/D non-multiplexed mode and unused in A/D multiplexed mode	OZ	AA14
GPMC0_A19	GPMC address 19 Output in A/D non-multiplexed mode and unused in A/D multiplexed mode	OZ	AA18
GPMC0_A20	GPMC address 20 Output in A/D non-multiplexed mode and unused in A/D multiplexed mode	OZ	AA16
GPMC0_A21	GPMC address 21 Output in A/D non-multiplexed mode and unused in A/D multiplexed mode	OZ	W17
GPMC0_A22	GPMC address 22 Output in A/D non-multiplexed mode and unused in A/D multiplexed mode	OZ	U17
GPMC0_AD0	GPMC Data 0 Input/Output in A/D non-multiplexed mode and additionally Address 1 Output in A/D multiplexed mode	IO	AA17
GPMC0_AD1	GPMC Data 1 Input/Output in A/D non-multiplexed mode and additionally Address 2 Output in A/D multiplexed mode	IO	Y15
GPMC0_AD2	GPMC Data 2 Input/Output in A/D non-multiplexed mode and additionally Address 3 Output in A/D multiplexed mode	IO	AA20
GPMC0_AD3	GPMC Data 3 Input/Output in A/D non-multiplexed mode and additionally Address 4 Output in A/D multiplexed mode	IO	Y17

Table 6-85. GPMC0 Signal Descriptions (continued)

SIGNAL NAME [1]	DESCRIPTION [2]	PIN TYPE [3]	BALL [4]
GPMC0_AD4	GPMC Data 4 Input/Output in A/D non-multiplexed mode and additionally Address 5 Output in A/D multiplexed mode	IO	Y16
GPMC0_AD5	GPMC Data 5 Input/Output in A/D non-multiplexed mode and additionally Address 6 Output in A/D multiplexed mode	IO	V17
GPMC0_AD6	GPMC Data 6 Input/Output in A/D non-multiplexed mode and additionally Address 7 Output in A/D multiplexed mode	IO	AA19
GPMC0_AD7	GPMC Data 7 Input/Output in A/D non-multiplexed mode and additionally Address 8 Output in A/D multiplexed mode	IO	V16
GPMC0_AD8	GPMC Data 8 Input/Output in A/D non-multiplexed mode and additionally Address 9 Output in A/D multiplexed mode	IO	Y18
GPMC0_AD9	GPMC Data 9 Input/Output in A/D non-multiplexed mode and additionally Address 10 Output in A/D multiplexed mode	IO	Y19
GPMC0_AD10	GPMC Data 10 Input/Output in A/D non-multiplexed mode and additionally Address 11 Output in A/D multiplexed mode	IO	Y21
GPMC0_AD11	GPMC Data 11 Input/Output in A/D non-multiplexed mode and additionally Address 12 Output in A/D multiplexed mode	IO	W15
GPMC0_AD12	GPMC Data 12 Input/Output in A/D non-multiplexed mode and additionally Address 13 Output in A/D multiplexed mode	IO	Y20
GPMC0_AD13	GPMC Data 13 Input/Output in A/D non-multiplexed mode and additionally Address 14 Output in A/D multiplexed mode	IO	U14
GPMC0_AD14	GPMC Data 14 Input/Output in A/D non-multiplexed mode and additionally Address 15 Output in A/D multiplexed mode	IO	U16
GPMC0_AD15	GPMC Data 15 Input/Output in A/D non-multiplexed mode and additionally Address 16 Output in A/D multiplexed mode	IO	U15
GPMC0_BE0n_CLE	GPMC Lower-Byte Enable (active low) or Command Latch Enable	O	U20
GPMC0_BE1n	GPMC Upper-Byte Enable (active low)	O	AA15
GPMC0_CSn0	GPMC Chip Select 0 (active low)	O	T20
GPMC0_CSn1	GPMC Chip Select 1 (active low)	O	U21
GPMC0_CSn2	GPMC Chip Select 2 (active low)	O	W17
GPMC0_CSn3	GPMC Chip Select 3 (active low)	O	AA16
GPMC0_WAIT0	GPMC External Indication of Wait	I	T16
GPMC0_WAIT1	GPMC External Indication of Wait	I	U17

6.3.20 MMC**6.3.20.1 MAIN Domain****Table 6-86. MMC0 Signal Descriptions**

SIGNAL NAME [1]	DESCRIPTION [2]	PIN TYPE [3]	BALL [4]
MMC0_CALPAD ⁽¹⁾	MMC/SD/SDIO Calibration Resistor	A	P20
MMC0_CLK	MMC/SD/SDIO Clock	O	P18

Table 6-86. MMC0 Signal Descriptions (continued)

SIGNAL NAME [1]	DESCRIPTION [2]	PIN TYPE [3]	BALL [4]
MMC0_CMD	MMC/SD/SDIO Command	IO	R17
MMC0_DS	MMC Data Strobe	IO	P19
MMC0_DAT0	MMC/SD/SDIO Data	IO	R16
MMC0_DAT1	MMC/SD/SDIO Data	IO	P17
MMC0_DAT2	MMC/SD/SDIO Data	IO	R18
MMC0_DAT3	MMC/SD/SDIO Data	IO	R20
MMC0_DAT4	MMC/SD/SDIO Data	IO	R19
MMC0_DAT5	MMC/SD/SDIO Data	IO	P16
MMC0_DAT6	MMC/SD/SDIO Data	IO	R21
MMC0_DAT7	MMC/SD/SDIO Data	IO	T21

(1) An external 10 kΩ ±1% resistor must be connected between this pin and VSS. No external voltage should be applied to this pin.

Table 6-87. MMC1 Signal Descriptions

SIGNAL NAME [1]	DESCRIPTION [2]	PIN TYPE [3]	BALL [4]
MMC1_CLK ⁽¹⁾	MMC/SD/SDIO Clock	IO	P21
MMC1_CMD	MMC/SD/SDIO Command	IO	M20
MMC1_SDCD ⁽²⁾	SD Card Detect	I	V1
MMC1_SDWP	SD Write Protect	I	W1
MMC1_DAT0	MMC/SD/SDIO Data	IO	M19
MMC1_DAT1	MMC/SD/SDIO Data	IO	N21
MMC1_DAT2	MMC/SD/SDIO Data	IO	N20
MMC1_DAT3	MMC/SD/SDIO Data	IO	N19

(1) For MMC1_CLK signal to work properly, the RXACTIVE bit of the CTRLMMR_PADCONFIG63 register should be set to 0x1 because of retiming purposes.

(2) For ROM boot to work properly, the MMC1_SDCD pin should be pulled low externally with a resistor.

6.3.21 CPTS

6.3.21.1 MAIN Domain

Table 6-88. CPTS0 Signal Descriptions

SIGNAL NAME [1]	DESCRIPTION [2]	PIN TYPE [3]	BALL [4]
CPTS0_RFT_CLK	CPTS Reference Clock	I	U3
CPTS0_TS_COMP	CPTS Time Stamp Counter Compare	O	U5
CPTS0_TS_SYNC	CPTS Time Stamp Counter Bit	O	N20
CPTS0_HW1TSPUSH	CPTS Hardware Time Stamp Push 1	I	U3
CPTS0_HW2TSPUSH	CPTS Hardware Time Stamp Push 2	I	T3

6.3.21.2 MCU Domain

Table 6-89. CPTS0 Signal Descriptions

SIGNAL NAME [1]	DESCRIPTION [2]	PIN TYPE [3]	BALL [4]
MCU_CPTS0_RFT_CLK	CPTS Reference Clock	I	C20, E18
MCU_CPTS0_TS_COMP	CPTS Time Stamp Counter Compare	O	C19
MCU_CPTS0_TS_SYNC	CPTS Time Stamp Counter Bit	O	C21
MCU_CPTS0_HW1TSPUSH	CPTS Hardware Time Stamp Push 1	I	C14

Table 6-89. CPTS0 Signal Descriptions (continued)

SIGNAL NAME [1]	DESCRIPTION [2]	PIN TYPE [3]	BALL [4]
MCU_CPTS0_HW2TSPUSH	CPTS Hardware Time Stamp Push 2	I	C18

6.3.22 MCASP**6.3.22.1 MAIN Domain****Table 6-90. MCASP0 Signal Descriptions**

SIGNAL NAME [1]	DESCRIPTION [2]	PIN TYPE [3]	BALL [4]
MCASP0_ACLKR	MCASP Receive Bit Clock	IO	U17
MCASP0_ACLKX	MCASP Transmit Bit Clock	IO	W15
MCASP0_AFSR	MCASP Receive Frame Sync	IO	U15
MCASP0_AFSX	MCASP Transmit Frame Sync	IO	Y16
MCASP0_AXR0	MCASP Serial Data (Input/Output)	IO	W16
MCASP0_AXR1	MCASP Serial Data (Input/Output)	IO	Y21
MCASP0_AXR2	MCASP Serial Data (Input/Output)	IO	Y20
MCASP0_AXR3	MCASP Serial Data (Input/Output)	IO	AA19
MCASP0_AXR4	MCASP Serial Data (Input/Output)	IO	U19
MCASP0_AXR5	MCASP Serial Data (Input/Output)	IO	T15
MCASP0_AXR6	MCASP Serial Data (Input/Output)	IO	U20
MCASP0_AXR7	MCASP Serial Data (Input/Output)	IO	V21
MCASP0_AXR8	MCASP Serial Data (Input/Output)	IO	V17
MCASP0_AXR9	MCASP Serial Data (Input/Output)	IO	V18
MCASP0_AXR10	MCASP Serial Data (Input/Output)	IO	V20
MCASP0_AXR11	MCASP Serial Data (Input/Output)	IO	W21
MCASP0_AXR12	MCASP Serial Data (Input/Output)	IO	V16
MCASP0_AXR13	MCASP Serial Data (Input/Output)	IO	Y14
MCASP0_AXR14	MCASP Serial Data (Input/Output)	IO	Y13
MCASP0_AXR15	MCASP Serial Data (Input/Output)	IO	AA15

Table 6-91. MCASP1 Signal Descriptions

SIGNAL NAME [1]	DESCRIPTION [2]	PIN TYPE [3]	BALL [4]
MCASP1_ACLKR	MCASP Receive Bit Clock	IO	U18
MCASP1_ACLKX	MCASP Transmit Bit Clock	IO	Y19
MCASP1_AFSR	MCASP Receive Frame Sync	IO	T14
MCASP1_AFSX	MCASP Transmit Frame Sync	IO	Y18
MCASP1_AXR0	MCASP Serial Data (Input/Output)	IO	Y17
MCASP1_AXR1	MCASP Serial Data (Input/Output)	IO	AA20
MCASP1_AXR2	MCASP Serial Data (Input/Output)	IO	Y15
MCASP1_AXR3	MCASP Serial Data (Input/Output)	IO	AA17
MCASP1_AXR4	MCASP Serial Data (Input/Output)	IO	U16
MCASP1_AXR5	MCASP Serial Data (Input/Output)	IO	U14
MCASP1_AXR6	MCASP Serial Data (Input/Output)	IO	T13
MCASP1_AXR7	MCASP Serial Data (Input/Output)	IO	V19
MCASP1_AXR8	MCASP Serial Data (Input/Output)	IO	AA14
MCASP1_AXR9	MCASP Serial Data (Input/Output)	IO	AA18
MCASP1_AXR10	MCASP Serial Data (Input/Output)	IO	T14

Table 6-91. MCASP1 Signal Descriptions (continued)

SIGNAL NAME [1]	DESCRIPTION [2]	PIN TYPE [3]	BALL [4]
MCASP1_AXR11	MCASP Serial Data (Input/Output)	IO	U18

Table 6-92. MCASP2 Signal Descriptions

SIGNAL NAME [1]	DESCRIPTION [2]	PIN TYPE [3]	BALL [4]
MCASP2_ACLKR	MCASP Receive Bit Clock	IO	W19
MCASP2_ACLKX	MCASP Transmit Bit Clock	IO	U12
MCASP2_AFSR	MCASP Receive Frame Sync	IO	W14
MCASP2_AFSX	MCASP Transmit Frame Sync	IO	V13
MCASP2_AXR0	MCASP Serial Data (Input/Output)	IO	AA16
MCASP2_AXR1	MCASP Serial Data (Input/Output)	IO	W17
MCASP2_AXR2	MCASP Serial Data (Input/Output)	IO	W20
MCASP2_AXR3	MCASP Serial Data (Input/Output)	IO	V14
MCASP2_AXR4	MCASP Serial Data (Input/Output)	IO	W14
MCASP2_AXR5	MCASP Serial Data (Input/Output)	IO	W19

6.3.23 DMTIMER

6.3.23.1 MAIN Domain

Table 6-93. DMTIMER Signal Descriptions

SIGNAL NAME [1]	DESCRIPTION [2]	PIN TYPE [3]	BALL [4]
TIMER_IO0	Timer Inputs and Outputs (not tied to single timer instance)	IO	N19, V1
TIMER_IO1	Timer Inputs and Outputs (not tied to single timer instance)	IO	N20, W1
TIMER_IO2	Timer Inputs and Outputs (not tied to single timer instance)	IO	N21
TIMER_IO3	Timer Inputs and Outputs (not tied to single timer instance)	IO	M19
TIMER_IO4	Timer Inputs and Outputs (not tied to single timer instance)	IO	P21
TIMER_IO5	Timer Inputs and Outputs (not tied to single timer instance)	IO	M20
TIMER_IO6	Timer Inputs and Outputs (not tied to single timer instance)	IO	T18
TIMER_IO7	Timer Inputs and Outputs (not tied to single timer instance)	IO	T20

6.3.23.2 MCU Domain

Table 6-94. DMTIMER Signal Descriptions

SIGNAL NAME [1]	DESCRIPTION [2]	PIN TYPE [3]	BALL [4]
MCU_TIMER_IO0	Timer Inputs and Outputs (not tied to single timer instance)	IO	B17
MCU_TIMER_IO1	Timer Inputs and Outputs (not tied to single timer instance)	IO	A19, C16
MCU_TIMER_IO2	Timer Inputs and Outputs (not tied to single timer instance)	IO	C12
MCU_TIMER_IO3	Timer Inputs and Outputs (not tied to single timer instance)	IO	B12

Table 6-94. DMTIMER Signal Descriptions (continued)

SIGNAL NAME [1]	DESCRIPTION [2]	PIN TYPE [3]	BALL [4]
MCU_TIMER_IO4	Timer Inputs and Outputs (not tied to single timer instance)	IO	C10
MCU_TIMER_IO5	Timer Inputs and Outputs (not tied to single timer instance)	IO	A10
MCU_TIMER_IO6	Timer Inputs and Outputs (not tied to single timer instance)	IO	C21, D21
MCU_TIMER_IO7	Timer Inputs and Outputs (not tied to single timer instance)	IO	C19, E19
MCU_TIMER_IO8	Timer Inputs and Outputs (not tied to single timer instance)	IO	E20
MCU_TIMER_IO9	Timer Inputs and Outputs (not tied to single timer instance)	IO	E21

6.3.24 Emulation and Debug

6.3.24.1 MAIN Domain

Table 6-95. JTAG Signal Descriptions

SIGNAL NAME [1]	DESCRIPTION [2]	PIN TYPE [3]	BALL [4]
EMU0	Emulation Control 0	IO	A13
EMU1	Emulation Control 1	IO	D12
TCK	JTAG Test Clock Input	I	B15
TDI	JTAG Test Data Input	I	F19
TDO	JTAG Test Data Output	OZ	F21
TMS	JTAG Test Mode Select Input	I	U4
TRSTn	JTAG Reset	I	B20

Table 6-96. Trace Signal Descriptions

SIGNAL NAME [1]	DESCRIPTION [2]	PIN TYPE [3]	BALL [4]
TRC_CLK	Trace Clock	O	W15
TRC_CTL	Trace Control	O	Y16
TRC_DATA0	Trace Data 0	O	W16
TRC_DATA1	Trace Data 1	O	Y21
TRC_DATA2	Trace Data 2	O	Y19
TRC_DATA3	Trace Data 3	O	Y18
TRC_DATA4	Trace Data 4	O	Y20
TRC_DATA5	Trace Data 5	O	AA19
TRC_DATA6	Trace Data 6	O	Y17
TRC_DATA7	Trace Data 7	O	AA20
TRC_DATA8	Trace Data 8	O	Y15
TRC_DATA9	Trace Data 9	O	AA17
TRC_DATA10	Trace Data 10	O	U17
TRC_DATA11	Trace Data 11	O	U15
TRC_DATA12	Trace Data 12	O	U18
TRC_DATA13	Trace Data 13	O	T14
TRC_DATA14	Trace Data 14	O	U19
TRC_DATA15	Trace Data 15	O	T15
TRC_DATA16	Trace Data 16	O	U20

Table 6-96. Trace Signal Descriptions (continued)

SIGNAL NAME [1]	DESCRIPTION [2]	PIN TYPE [3]	BALL [4]
TRC_DATA17	Trace Data 17	O	V21
TRC_DATA18	Trace Data 18	O	U16
TRC_DATA19	Trace Data 19	O	U14
TRC_DATA20	Trace Data 20	O	T13
TRC_DATA21	Trace Data 21	O	V19
TRC_DATA22	Trace Data 22	O	W14
TRC_DATA23	Trace Data 23	O	W19

6.3.25 System and Miscellaneous

6.3.25.1 Boot Mode Configuration

6.3.25.1.1 MAIN Domain

Table 6-97. Sysboot Signal Descriptions

SIGNAL NAME [1]	DESCRIPTION [2]	PIN TYPE [3]	BALL [4]
BOOTMODE00	Bootmode pin 0	I	D8
BOOTMODE01	Bootmode pin 1	I	C7
BOOTMODE02	Bootmode pin 2	I	A6
BOOTMODE03	Bootmode pin 3	I	B8
BOOTMODE04	Bootmode pin 4	I	D21
BOOTMODE05	Bootmode pin 5	I	E19
BOOTMODE06	Bootmode pin 6	I	D18
BOOTMODE07	Bootmode pin 7	I	C17

6.3.25.1.2 MCU Domain

Table 6-98. Sysboot Signal Descriptions

SIGNAL NAME [1]	DESCRIPTION [2]	PIN TYPE [3]	BALL [4]
MCU_BOOTMODE00	Bootmode pin 00	I	C13
MCU_BOOTMODE01	Bootmode pin 01	I	A20
MCU_BOOTMODE02	Bootmode pin 02	I	B17
MCU_BOOTMODE03	Bootmode pin 03	I	B18
MCU_BOOTMODE04	Bootmode pin 04	I	B19
MCU_BOOTMODE05	Bootmode pin 05	I	D14
MCU_BOOTMODE06	Bootmode pin 06	I	E20
MCU_BOOTMODE07	Bootmode pin 07	I	E21
MCU_BOOTMODE08	Bootmode pin 08	I	D19
MCU_BOOTMODE09	Bootmode pin 09	I	D20

6.3.25.2 Clock

6.3.25.2.1 MAIN Domain

Table 6-99. Clock1 Signal Descriptions

SIGNAL NAME [1]	DESCRIPTION [2]	PIN TYPE [3]	BALL [4]
OSC1_XI	High frequency oscillator input	I	K19
OSC1_XO	High frequency oscillator output	O	J19

6.3.25.2.2 WKUP Domain

Table 6-100. Clock0 Signal Descriptions

SIGNAL NAME [1]	DESCRIPTION [2]	PIN TYPE [3]	BALL [4]
WKUP_LF_CLKIN	Low frequency (32.768 KHz) oscillator input	I	C17
WKUP_OSC0_XI	High frequency oscillator input	I	K21
WKUP_OSC0_XO	High frequency oscillator output	O	L21

6.3.25.3 System

6.3.25.3.1 MAIN Domain

Table 6-101. System0 Signal Descriptions

SIGNAL NAME [1]	DESCRIPTION [2]	PIN TYPE [3]	BALL [4]
AUDIO_EXT_REFCLK0	External clock routed to ATL or McASP as one of the selectable input clock sources, or as a output clock output for ATL or McASP	IO	V18
AUDIO_EXT_REFCLK1	External clock routed to ATL or McASP as one of the selectable input clock sources, or as a output clock output for ATL or McASP	IO	U21
EXTINTn	External Interrupt	I	U6
EXT_REFCLK1	External clock input to Main Domain, routed to Timer clock muxes as one of the selectable input clock sources for Timer/WDT modules, or as reference clock to MAIN_PLL2 (PER1 PLL)	I	T3
GPMC0_FCLK_MUX	GPMC functional clock output selected through a mux logic	O	V14
OBSCLK0	Observation clock output for test and debug purposes only	O	W1
OBSCLK1	Observation clock output for test and debug purposes only	O	V16
OBSCLK2	Observation clock output for test and debug purposes only	O	V14
RESETSTATz	Main Domain warm reset status output	O	U2
SOC_SAFETY_ERRORn	Error signal output from Main Domain ESM	IO	V2
SYNC0_OUT	CPTS Time Stamp Generator Bit 0	O	U3
SYNC1_OUT	CPTS Time Stamp Generator Bit 1	O	T3
SYNC2_OUT	CPTS Time Stamp Generator Bit 2	O	W16
SYNC3_OUT	CPTS Time Stamp Generator Bit 3	O	V21
SYSCLKOUT0	SYSCLK0 output from Main PLL controller (divided by 6) for test and debug purposes only	O	V1

6.3.25.3.2 WKUP Domain

Table 6-102. System0 Signal Descriptions

SIGNAL NAME [1]	DESCRIPTION [2]	PIN TYPE [3]	BALL [4]
MCU_CLKOUT0	Reference clock output for Ethernet PHYs (50MHz or 25MHz)	OZ	C16
MCU_EXT_REFCLK0	External system clock input	I	C20, E18
MCU_OBSCLK0	Observation clock output for test and debug purposes only	O	C16
MCU_PORz	MCU Domain cold reset	I	G19
MCU_RESETSTATz	MCU Domain warm reset status output	O	B13

Table 6-102. System0 Signal Descriptions (continued)

SIGNAL NAME [1]	DESCRIPTION [2]	PIN TYPE [3]	BALL [4]
MCU_RESEZt	MCU Domain warm reset	I	A18
MCU_SAFETY_ERRORn	Error signal output from MCU Domain ESM	IO	G18
MCU_SYSCLKOUT0	MCU Domain system clock output for test and debug purposes only	O	C20
PMIC_POWER_EN1	Power enable output for MAIN Domain supplies	O	C15
PMIC_WAKE0n	PMIC WakeUp (active low)	OD	T19
PMIC_WAKE1n	PMIC WakeUp (active low)	OD	E18
PORz	Main Domain cold reset	I	H20
RESET_REQz	Main Domain external warm reset request input	I	A15

6.3.25.3.3 VMON

Table 6-103. VMON Signal Description

SIGNAL NAME [1]	DESCRIPTION [2]	PIN TYPE [3]	BALL [4]
VMON1_ER_VSYS	Voltage Monitor, fixed 0.45V (+/-3%) threshold. Use with external precision voltage divider to monitor a higher voltage rail such as the PMIC input supply.	PWR	G15
VMON2_IR_VCPU	Must be externally connected directly to VDD_CPU	PWR	D16
VMON3_IR_VEXT1P8	General purpose voltage monitor for external supplies, 1.8V threshold. With internal resistor Divider.	PWR	E17
VMON4_IR_VEXT1P8	General purpose voltage monitor for external supplies, 1.8V threshold. With internal resistor Divider.	PWR	F17
VMON5_IR_VEXT3P3	General purpose voltage monitor for external supplies, 3.3V threshold. With internal resistor Divider.	PWR	L14

6.3.25.4 EFUSE

Table 6-104. EFUSE Signal Description

SIGNAL NAME [1]	DESCRIPTION [2]	PIN TYPE [3]	BALL [4]
VPP_CORE ⁽¹⁾	Programming voltage for MAIN Domain efuses	PWR	N17
VPP_MCU ⁽¹⁾	Programming voltage for MCU Domain efuses	PWR	E11

(1) This signal is valid only for High-Security devices. For more details, see [Section 7.7, VPP Specification for One-Time Programmable \(OTP\) eFUSES](#). For General-Purpose devices do not connect any signal, test point, or board trace to this signal.

6.3.26 Power Supply

Note

All power balls must be supplied with the voltages specified in [Section 7.3, Recommended Operating Conditions](#), unless otherwise specified in [Section 6.3, Signal Descriptions](#).

Table 6-105. Power Supply Signal Description

SIGNAL NAME [1]	DESCRIPTION [2]	PIN TYPE [3]	BALL [4]
CAP_VDDS0 ⁽¹⁾	External capacitor connection for MAIN domain GENERAL IO group 0	PWR	M7
CAP_VDDS0_MCU ⁽¹⁾	External capacitor connection for MCUSS IO group 0	PWR	G14
CAP_VDDS1_MCU ⁽¹⁾	External capacitor connection for MCUSS IO group 1	PWR	F9
CAP_VDDS2 ⁽¹⁾	External capacitor connection for MAIN domain CANUART IO group 2	PWR	T12

Table 6-105. Power Supply Signal Description (continued)

SIGNAL NAME [1]	DESCRIPTION [2]	PIN TYPE [3]	BALL [4]
CAP_VDDS2_MCU ⁽¹⁾	External capacitor connection for MCUSS IO group 2	PWR	F10
CAP_VDDS5 ⁽¹⁾	External capacitor connection for MAIN domain MMC1 IO group 5	PWR	L15
VDDAR_CORE	MAIN domain RAM supply	PWR	K14, P14
VDDAR_CPU	CPU RAM supply	PWR	J11, M10
VDDAR_MCU	MCUSS RAM supply	PWR	H12, J14
VDDA_0P8_PLL_DDR	DDR PLL analog supply	PWR	K7
VDDA_0P8_USB	USB0 0.8 V analog supply	PWR	P7
VDDA_0P8_DLL_MMC0	MMC0 DLL analog supply	PWR	M18
VDDA_0P8_SERDES0	SERDES0 analog supply low	PWR	R8, T7, U8
VDDA_0P8_SERDES0_C	SERDES0 clock supply	PWR	R9
VDDA_1P8_USB	USB0 1.8 V analog supply	PWR	R6
VDDA_1P8_SERDES0	SERDES0 analog supply high	PWR	P8
VDDA_3P3_USB	USB0 3.3 V analog supply	PWR	R7
VDDA_ADC_MCU	ADC analog supply and high voltage reference (VREFP)	PWR	J16
VDDA_MCU_PLLGRP0	Analog supply for MCU PLL group 0	PWR	F15
VDDA_MCU_TEMP	Analog supply for temperature sensor 0 in MCU domain	PWR	F16
VDDA_PLLGRP0	Analog supply for MAIN PLL group 0	PWR	N14
VDDA_PLLGRP4	Analog supply for MAIN PLL group 4	PWR	N9
VDDA_PLLGRP6	Analog supply for MAIN PLL Group 6	PWR	J9
VDDA_PLLGRP8	Analog supply for MAIN PLL group 8	PWR	L7
VDDA_POR_WKUP	WKUP domain analog supply	PWR	J15
VDDA_TEMP0	Analog supply for MAIN domain TEMP sensor 0	PWR	J8
VDDA_TEMP1	Analog supply for MAIN domain TEMP sensor 1	PWR	P15
VDDA_WKUP	Oscillator supply for WKUP domain	PWR	H16
VDDSHV0	IO supply for MAIN domain GENERAL IO group	PWR	N6, P6
VDDSHV0_MCU	IO supply MCUSS general IO group, and MCU and MAIN domain warm reset pins	PWR	E13, E14, F13, F14
VDDSHV1_MCU	IO supply for MCUSS IO group 1	PWR	E7, E8, F8
VDDSHV2	IO supply for MAIN domain CANUART IO group 2	PWR	T10, U11, U9
VDDSHV2_MCU	IO supply for MCUSS IO group 2	PWR	F11, F12, G11
VDDSHV5	IO supply for MAIN domain MMC1 IO group 5	PWR	K16, L16
VDDS_DDR	DDR interface power supply	PWR	A1, G7, H6, J7, K6, M5, U1
VDDS_DDR_BIAS	Bias supply for LPDDR4	PWR	F7, L6
VDDS_DDR_C	IO power for DDR Memory Clock Bit (MCB) macro	PWR	J6
VDDS_MMC0	MMC0 IO supply	PWR	M16, N16
VDDA_OSC1	HFOSC1 supply	PWR	G17
VDD_CORE	MAIN domain core supply	PWR	H8, K12, L13, M12, M14, N13, N15, N7, P10, P12, R11, R13, R15
VDD_CPU	CPU core supply	PWR	J10, L11, M9, N11, N8
VDD_MCU	MCUSS core supply	PWR	G9, H10, H14, J13, K15
VDD_MCU_WAKE1	Core supply for MCU WAKE function	PWR	G13

Table 6-105. Power Supply Signal Description (continued)

SIGNAL NAME [1]	DESCRIPTION [2]	PIN TYPE [3]	BALL [4]
VDD_WAKE0	Core supply for MAIN domain WAKE function which includes all "CANUART" IO.	PWR	P11
VSS	Ground	GND	B5, AA1, AA10, AA13, AA4, AA7, C11, D15, D17, D3, E10, E12, E15, E16, E6, E9, F1, G10, G12, G16, G6, G8, H11, H13, H15, H19, H4, H7, H9, J1, J12, J21, K11, K13, K3, L12, L19, L5, M11, M13, M15, M21, M6, M8, N10, N12, N3, P13, P5, P9, R10, R12, R14, T11, T2, T6, T8, T9, U10, U7, V11, V12, V9, W10, W13, W18, W4, W7, Y12, Y3, Y6, Y9

(1) This pin must always be connected via a 1- μ F \pm 10% capacitor to VSS.

6.4 Pin Multiplexing

Note

Many device pins support multiple signal functions. Some signal functions are selected via a single layer of multiplexers associated with pins. Other signal functions are selected via two or more layers of multiplexers, where one layer is associated with the pins and other layers are associated with peripheral logic functions.

[Table 6-106, Pin Multiplexing](#) only describes signal multiplexing at the pins. For more information, related to signal multiplexing at the pins, see *Pad Configuration Registers* section in *Device Configuration* chapter in the device TRM. Refer to the respective peripheral chapter in the device TRM for information associated with peripheral signal multiplexing.

Note

When a pad is set into a pin multiplexing mode which is not defined, that pad's behavior is undefined. This should be avoided.

Note

[Table 6-106, Pin Multiplexing](#) does not include SerDes signal functions. For more information, refer to the Serializer/Deserializer (SerDes) chapter in the device TRM.

Note

The PRU contains a second layer of multiplexing to enable additional functionality on the PRU GPO and GPI signals. This internal wrapper multiplexing is described in the PRU chapter in the device TRM.

For more information on the I/O cell configurations, see *Pad Configuration Registers* section in *Device Configuration* chapter in the device TRM.

Table 6-106. Pin Multiplexing

ADDRESS OFFSET	REGISTER NAME	BALL NUMBER	MUXMODE[15:0] SETTINGS															
			0	1	2	3	4	5	6	7	8	9	10	11	12	13	14	Bootstrap
0x1C000	WKUP_PADCONFIG_0	B6	MCU_OSPI0_CLK	MCU_HYPERBUS0_CLK							WKUP_GPIO0_16							
0x1C000	PADCONFIG_0	U6	EXTINTn								GPIO0_0							
0x1C004	WKUP_PADCONFIG_1	C8	MCU_OSPI0_LBCLKO	MCU_HYPERBUS0_CLKn							WKUP_GPIO0_17							
0x1C004	PADCONFIG_1	AA17	RMII1_RXD0				RGMI1_RXD0	RMII1_RXD0	MCAN14_TX	GPIO0_2			TRC_DATA9	UART5_TXD	MCASP1_AXR3		GPMC0_A0	
0x1C008	PADCONFIG_2	Y15	RMII1_RXD1				RGMI1_RXD1	RMII1_RXD1	MCAN14_RX	GPIO0_3			EHRPWM_TZn_IN2	TRC_DATA8	UART5_RXD	MCASP1_AXR2		GPMC0_A0D1

Table 6-106. Pin Multiplexing (continued)

ADDR ESS OFFSE T	REGISTER NAME	BALL NUMB ER	MUXMODE[15:0] SETTINGS														Bootstrap		
			0	1	2	3	4	5	6	7	8	9	10	11	12	13		14	
0x1C008	WKUP_PADCONFIG_2	B7	MCU_OSPI0_DQS	MCU_HYP ERBUS0_RWDS							WKUP_GP IO0_18								
0x1C00C	PADCONFIG_3	AA20	RMI11_CR S_DV					RGMII1_R D2	RMI11_CR S_DV		GPIO0_4		EHRPWM2_B	TRC_DATA7	UART4_TX D	MCASP1_AXR1		GPMC0_A D2	
0x1C00C	WKUP_PADCONFIG_3	D8	MCU_OSPI0_D0	MCU_HYP ERBUS0_DQ0							WKUP_GP IO0_19								BOOTMOD E00
0x1C010	PADCONFIG_4	Y17	RMI11_RX_ER					RGMII1_R D3	RMI11_RX_ER		GPIO0_5		EHRPWM2_A	TRC_DATA6	UART6_TX D	MCASP1_AXR0		GPMC0_A D3	
0x1C010	WKUP_PADCONFIG_4	C7	MCU_OSPI0_D1	MCU_HYP ERBUS0_DQ1							WKUP_GP IO0_20								BOOTMOD E01
0x1C014	WKUP_PADCONFIG_5	C5	MCU_OSPI0_D2	MCU_HYP ERBUS0_DQ2							WKUP_GP IO0_21								
0x1C014	PADCONFIG_5	Y16	RMI11_TXD0					RGMII1_R X_CTL	RMI11_TXD0		GPIO0_6		EHRPWM0_SYNCO	TRC_CTL	UART6_RX D	MCASP0_AFSX		GPMC0_A D4	
0x1C018	WKUP_PADCONFIG_6	A5	MCU_OSPI0_D3	MCU_HYP ERBUS0_DQ3							WKUP_GP IO0_22								
0x1C018	PADCONFIG_6	V17	RMI11_TX_EN					RGMII4_R XC	RMI11_TX_EN		GPIO0_7		EQEP2_A		UART9_TX D	MCASP0_AXR8	I2C1_SCL	GPMC0_A D5	
0x1C01C	PADCONFIG_7	AA19	RMI11_TXD1					RGMII1_R XC	RMI11_TXD1		GPIO0_8		EHRPWM_TZn_IN1	TRC_DATA5	UART9_RX D	MCASP0_AXR3	I2C1_SDA	GPMC0_A D6	
0x1C01C	WKUP_PADCONFIG_7	A6	MCU_OSPI0_D4	MCU_HYP ERBUS0_DQ4							WKUP_GP IO0_23								BOOTMOD E02
0x1C020	WKUP_PADCONFIG_8	B8	MCU_OSPI0_D5	MCU_HYP ERBUS0_DQ5							WKUP_GP IO0_24								BOOTMOD E03
0x1C020	PADCONFIG_8	V18	MCAN0_TX					RGMII4_R D0		MCAN0_TX	GPIO0_9		EQEP2_B		GPMC0_A1	MCASP0_AXR9		AUDIO_EX T_REFCLK0	
0x1C024	PADCONFIG_9	V20	MCAN0_RX					RGMII4_R D1		MCAN0_RX	GPIO0_10		EQEP2_S		GPMC0_A2	MCASP0_AXR10			
0x1C024	WKUP_PADCONFIG_9	A8	MCU_OSPI0_D6	MCU_HYP ERBUS0_DQ6							WKUP_GP IO0_25								
0x1C028	PADCONFIG_10	W21	MCAN1_TX					RGMII2_TX XC	RMI12_TX_EN	MCAN1_TX	GPIO0_11	SPI6_CS0	EHRPWM_SOC_A		GPMC0_A3	MCASP0_AXR11			
0x1C028	WKUP_PADCONFIG_10	A7	MCU_OSPI0_D7	MCU_HYP ERBUS0_DQ7							WKUP_GP IO0_26								
0x1C02C	PADCONFIG_11	V16	MCAN1_RX					RGMII4_R D2	RMI12_TXD1	MCAN1_RX	GPIO0_12	SPI6_CS1	EQEP2_I	GPMC0_A D7	UART6_CT Sn	MCASP0_AXR12		OBSCLK1	
0x1C02C	WKUP_PADCONFIG_11	D6	MCU_OSPI0_CSn0	MCU_HYP ERBUS0_CSn0							WKUP_GP IO0_27								

Table 6-106. Pin Multiplexing (continued)

ADDRESS OFFSET	REGISTER NAME	BALL NUMBER	MUXMODE[15:0] SETTINGS														Bootstrap	
			0	1	2	3	4	5	6	7	8	9	10	11	12	13		14
0x1C030	WKUP_PADCONFIG_12	D7	MCU_OSPI0_CSn1	MCU_HYP ERBUS0_RESETh							WKUP_GPIO0_28							
0x1C030	PADCONFIG_12	Y18	MCAN2_TX				RGMII1_TD0	RMII4_RXD0	MCAN2_TX	GPIO0_13	SPI5_CS3	EHRPWM1_A	TRC_DATA3	UART3_RXD	MCASP1_AFSX	UART9_CTSn	GPMC0_AD8	
0x1C034	PADCONFIG_13	Y19	MCAN2_RX				RGMII1_TD1	RMII4_RXD1	MCAN2_RX	GPIO0_14	SPI5_CS2	EHRPWM0_B	TRC_DATA2	UART3_TXD	MCASP1_ACLKX	UART9_RTSn	GPMC0_AD9	
0x1C038	PADCONFIG_14	Y21	MCAN3_TX				RGMII1_TD2	RMII4_CRS_DV	MCAN3_TX	GPIO0_15	SPI5_D0	EHRPWM0_A	TRC_DATA1		MCASP0_AXR1		GPMC0_AD10	
0x1C038	WKUP_PADCONFIG_14	C6	MCU_OSPI0_CSn2	MCU_OSPI0_CSn2	MCU_HYP ERBUS0_RESETh	MCU_HYP ERBUS0_WPn	MCU_HYP ERBUS0_CSn1		MCU_OSPI0_RESETh	MCU_OSPI0_ECC_FAIL	WKUP_GPIO0_30							
0x1C03C	WKUP_PADCONFIG_15	D5	MCU_OSPI0_CSn3	MCU_OSPI0_CSn3	MCU_HYP ERBUS0_INTn	MCU_HYP ERBUS0_WPn		MCU_OSPI0_OUT1	MCU_OSPI0_ECC_FAIL	WKUP_GPIO0_31								
0x1C03C	PADCONFIG_15	W16	MCAN3_RX				RGMII1_TD3	RMII4_RXER	MCAN3_RX	GPIO0_16	SPI5_CS0	EHRPWM_TZn_IN0	TRC_DATA0	GPMC0_A4	MCASP0_AXR0		SYNC2_OUT	
0x1C040	PADCONFIG_16	W15	MCAN4_TX				RGMII1_TX_CTL	RMII4_TXD0	MCAN4_TX	GPIO0_17	SPI5_CLK	EHRPWM0_SYNCI	TRC_CLK	I2C2_SCL	MCASP0_ACLKX		GPMC0_AD11	
0x1C044	PADCONFIG_17	Y20	MCAN4_RX				RGMII1_TXC	RMII4_TXEN	MCAN4_RX	GPIO0_18	SPI5_D1	EHRPWM1_B	TRC_DATA4	I2C2_SDA	MCASP0_AXR2		GPMC0_AD12	
0x1C048	PADCONFIG_18	V21	MCAN5_TX				RGMII3_RXC	RMII4_TXD1	MCAN5_TX	GPIO0_19	SPI5_CS1	EHRPWM4_B	TRC_DATA17	UART6_RTSn	MCASP0_AXR7	GPMC0_DIR	SYNC3_OUT	
0x1C04C	PADCONFIG_19	V19	MCAN5_RX				RGMII3_RXD0	RMII3_RXD0	MCAN5_RX	GPIO0_20	I2C3_SCL	EHRPWM_TZn_IN5	TRC_DATA21	GPMC0_A5	MCASP1_AXR7			
0x1C050	PADCONFIG_20	T13	MCAN6_TX				RGMII3_RXD1	RMII3_RXD1	MCAN6_TX	GPIO0_21	I2C3_SDA	EHRPWM5_B	TRC_DATA20	GPMC0_A6	MCASP1_AXR6			
0x1C054	PADCONFIG_21	U14	MCAN6_RX				RGMII3_RXD2	RMII3_CRS_DV	MCAN6_RX	GPIO0_22		EHRPWM5_A	TRC_DATA19		MCASP1_AXR5		GPMC0_AD13	
0x1C058	PADCONFIG_22	U16	MCAN7_TX				RGMII3_RXD3	RMII3_RXER	MCAN7_TX	GPIO0_23	SPI3_CS0	EHRPWM_TZn_IN4	TRC_DATA18		MCASP1_AXR4		GPMC0_AD14	
0x1C05C	PADCONFIG_23	U15	MCAN7_RX				RGMII3_RX_CTL	RMII3_TXD0	MCAN7_RX	GPIO0_24	SPI3_CS1	EHRPWM3_A	TRC_DATA11		MCASP0_AFSR		GPMC0_AD15	
0x1C060	PADCONFIG_24	T15	MCAN8_TX			GPMC0_A7	RGMII3_RXD0	RMII3_TXEN	MCAN8_TX	GPIO0_25	SPI3_CS2	EHRPWM_TZn_IN3	TRC_DATA15	UART3_CTSn	MCASP0_AXR5		UART0_CDn	
0x1C064	PADCONFIG_25	U19	MCAN8_RX				RGMII3_RXD1	RMII3_TXD1	MCAN8_RX	GPIO0_26	SPI3_CS3	EHRPWM3_SYNCO	TRC_DATA14	UART3_RTSn	MCASP0_AXR4	GPMC0_A8	UART0_DS Rn	
0x1C068	WKUP_PADCONFIG_26	D11	MCU_RGMII1_TX_CTL	MCU_RMII1_CRS_DV						WKUP_GPIO0_29								
0x1C068	PADCONFIG_26	T14	MCAN9_TX				RGMII3_RXD2		MCAN9_TX	GPIO0_27	SPI3_CLK	EHRPWM3_SYNCI	TRC_DATA13		MCASP1_AFSR	GPMC0_A9	MCASP1_AXR10	
0x1C06C	WKUP_PADCONFIG_27	A11	MCU_RGMII1_RX_CTL	MCU_RMII1_RX_ER						WKUP_GPIO0_43								
0x1C06C	PADCONFIG_27	U18	MCAN9_RX				RGMII3_RXD3		MCAN9_RX	GPIO0_28	SPI3_D0	EHRPWM3_B	TRC_DATA12		MCASP1_ACLKR	GPMC0_A10	MCASP1_AXR11	

Table 6-106. Pin Multiplexing (continued)

ADDRESS OFFSET	REGISTER NAME	BALL NUMBER	MUXMODE[15:0] SETTINGS															Bootstrap
			0	1	2	3	4	5	6	7	8	9	10	11	12	13	14	
0x1C070	WKUP_PADCONFIG_28	C12	MCU_RGMII1_TD3	MCU_TIMER_IO2		MCU_ADC_EXT_TRIGGER0					WKUP_GPIO0_44							
0x1C070	PADCONFIG_28	U17	MCAN10_TX				RGMII3_TX_CTL		MCAN10_TX	GPIO0_29	SPI3_D1	EHRPWM_SOCB	TRC_DATA10	UART2_CTSn	MCASP0_ACLKR	GPMC0_WAIT1	GPMC0_A22	
0x1C074	PADCONFIG_29	U20	MCAN10_RX				RGMII3_TXC		MCAN10_RX	GPIO0_30	SPI2_CLK	EHRPWM4_A	TRC_DATA16	UART2_RTSn	MCASP0_AXR6	GPMC0_BE0n_CLE	GPMC0_A16	
0x1C074	WKUP_PADCONFIG_29	B12	MCU_RGMII1_TD2	MCU_TIMER_IO3		MCU_ADC_EXT_TRIGGER1					WKUP_GPIO0_45							
0x1C078	WKUP_PADCONFIG_30	B11	MCU_RGMII1_TD1	MCU_RMII1_TXD1							WKUP_GPIO0_46							
0x1C078	PADCONFIG_30	Y14	MCAN11_TX				RGMII2_RXC		MCAN11_TX	GPIO0_31	SPI2_CS0	EQEP0_A		SPI0_CS2	UART3_RXD	MCASP0_AXR13	GPMC0_A11	UART0_DTRn
0x1C07C	PADCONFIG_31	Y13	MCAN11_RX				RGMII2_RXD0		MCAN11_RX	GPIO0_32	SPI2_CS1	EQEP0_B			UART3_TXD	MCASP0_AXR14	GPMC0_A12	UART0_RIn
0x1C07C	WKUP_PADCONFIG_31	D10	MCU_RGMII1_TD0	MCU_RMII1_TXD0							WKUP_GPIO0_47							
0x1C080	PADCONFIG_32	AA15	MCAN12_TX				RGMII2_RXD1		MCAN12_TX	GPIO0_33	SPI2_CS2	EQEP1_A	I2C6_SCL	UART2_RXD	MCASP0_AXR15	GPMC0_BE1n	GPMC0_A17	
0x1C080	WKUP_PADCONFIG_32	A12	MCU_RGMII1_TXC	MCU_RMII1_TX_EN							WKUP_GPIO0_48							
0x1C084	WKUP_PADCONFIG_33	B10	MCU_RGMII1_RXC	MCU_RMII1_REF_CLK							WKUP_GPIO0_49							
0x1C084	PADCONFIG_33	AA14	MCAN12_RX				RGMII2_RXD2		MCAN12_RX	GPIO0_34	SPI2_CS3	EQEP1_B	I2C6_SDA	UART2_TXD	MCASP1_AXR8	I3C0_SDA_PULLEN	GPMC0_A18	
0x1C088	PADCONFIG_34	AA18	MCAN13_TX				RGMII2_RXD3	GPMC0_WPn	MCAN13_TX	GPIO0_35	SPI2_D0	EQEP0_S	I2C5_SCL	UART8_CTSn	MCASP1_AXR9	I3C0_SCL	GPMC0_A19	
0x1C088	WKUP_PADCONFIG_34	C10	MCU_RGMII1_RD3	MCU_TIMER_IO4							WKUP_GPIO0_50							
0x1C08C	PADCONFIG_35	AA16	MCAN13_RX				RGMII2_RX_CTL	GPMC0_CSn3	MCAN13_RX	GPIO0_36	SPI2_D1	EQEP0_I	I2C5_SDA	UART8_RTSn	MCASP2_AXR0	I3C0_SDA	GPMC0_A20	
0x1C08C	WKUP_PADCONFIG_35	A10	MCU_RGMII1_RD2	MCU_TIMER_IO5							WKUP_GPIO0_51							
0x1C090	WKUP_PADCONFIG_36	B9	MCU_RGMII1_RD1	MCU_RMII1_RXD1							WKUP_GPIO0_52							
0x1C090	PADCONFIG_36	W17	MCAN15_TX				RGMII2_TD0	RMII2_RXD0		GPIO0_37	SPI6_CS2	EQEP1_S	MCAN15_TX	GPMC0_CSn2	MCASP2_AXR1	GPMC0_A0	GPMC0_A21	
0x1C094	PADCONFIG_37	W20	MCAN15_RX				RGMII2_TD1	RMII2_RXD1		GPIO0_38	SPI6_CS3	EQEP1_I	MCAN15_RX		MCASP2_AXR2	GPMC0_A15	GPMC0_A_DVn_ALE	
0x1C094	WKUP_PADCONFIG_37	A9	MCU_RGMII1_RD0	MCU_RMII1_RXD0							WKUP_GPIO0_53							
0x1C098	PADCONFIG_38	V14	UART2_RXD				RGMII2_TD2	RMII2_CRS_DV		GPIO0_39	SPI6_CLK	GPMC0_CLKOUT	GPMC0_FCLK_MUX	UART2_RXD	MCASP2_AXR3			OBSCLK2
0x1C098	WKUP_PADCONFIG_38	C9	MCU_MDI0_MDIO								WKUP_GPIO0_54							

Table 6-106. Pin Multiplexing (continued)

ADDR ESS OFFSE T	REGISTER NAME	BALL NUMB ER	MUXMODE[15:0] SETTINGS														Bootstrap		
			0	1	2	3	4	5	6	7	8	9	10	11	12	13		14	
0x1C09 C	PADCONFIG_39	V13	UART2_TX D					RGMII2_T D3	RMII2_RX_ ER		GPIO0_40	SPI6_D0			UART2_TX D	MCASP2_ AFSX			
0x1C09 C	WKUP_PADCON FIG_39	D9	MCU_MDI O0_MDC								WKUP_GP IO0_55								
0x1C0 A0	WKUP_PADCON FIG_40	C13	MCU_SPIO _CLK								WKUP_GP IO0_56								MCU_BOO TMODE00
0x1C0 A0	PADCONFIG_40	U12						RGMII2_T X_CTL	RMII2_TXD 0		GPIO0_41	SPI6_D1			UART4_RX D	MCASP2_ ACLKX	GPCM0_A 13		
0x1C0 A4	WKUP_PADCON FIG_41	A20	MCU_SPIO _D0								WKUP_GP IO0_57								MCU_BOO TMODE01
0x1C0 A4	PADCONFIG_41	W14	UART8_RX D		I2C4_SCL				MDIO0_M DIO		GPIO0_42			TRC_DATA 22	UART8_RX D	MCASP2_ AFSR	MCASP2_ AXR4		
0x1C0 A8	WKUP_PADCON FIG_42	B17	MCU_SPIO _D1					MCU_TIME R_IO0			WKUP_GP IO0_58								MCU_BOO TMODE02
0x1C0 A8	PADCONFIG_42	W19	UART8_TX D	SPI1_CS3	I2C4_SDA				MDIO0_M DC		GPIO0_43			TRC_DATA 23	UART8_TX D	MCASP2_ ACLKR	MCASP2_ AXR5		
0x1C0 AC	WKUP_PADCON FIG_43	A19	MCU_SPIO _CS0					MCU_TIME R_IO1			WKUP_GP IO0_59								
0x1C0 AC	PADCONFIG_43	U13	GPCM0_C LK	USB0_DR VVBUS				RGMII4_R D3			GPIO0_44			SPI0_CS3	UART9_RX D				
0x1C0 B0	WKUP_PADCON FIG_44	B14	WKUP_UA RT0_RXD								WKUP_GP IO0_60								
0x1C0 B0	PADCONFIG_44	T16	UART0_RX D					RGMII4_T XC			GPIO0_47								GPCM0_W AIT0
0x1C0 B4	PADCONFIG_45	T17	UART0_TX D					RGMII4_T D2			GPIO0_48								GPCM0_W En
0x1C0 B4	WKUP_PADCON FIG_45	A14	WKUP_UA RT0_TXD								WKUP_GP IO0_61								
0x1C0 B8	PADCONFIG_46	T18	UART1_RX D	MCAN17_T X			TIMER_IO 6	RGMII4_T D3			GPIO0_49								GPCM0_O En_REn
0x1C0 B8	WKUP_PADCON FIG_46	A16	MCU_MCA N0_TX								WKUP_GP IO0_62								
0x1C0 BC	PADCONFIG_47	T20	UART1_TX D	MCAN17_ RX			TIMER_IO 7	RGMII4_T X_CTL			GPIO0_50								GPCM0_C Sn0
0x1C0 BC	WKUP_PADCON FIG_47	A17	MCU_MCA N0_RX								WKUP_GP IO0_63								
0x1C0 C0	PADCONFIG_48	W3	SPI0_CS0		UART0_CT Sn						GPIO0_51								
0x1C0 C0	WKUP_PADCON FIG_48	B18	MCU_SPI1 _CLK	MCU_SPI1 _CLK							WKUP_GP IO0_0								MCU_BOO TMODE03
0x1C0 C4	PADCONFIG_49	U5	SPI0_CS1	CPTS0_TS _COMP	UART0_RT Sn						GPIO0_52								
0x1C0 C4	WKUP_PADCON FIG_49	B19	MCU_SPI1 _D0	MCU_SPI1 _D0							WKUP_GP IO0_1								MCU_BOO TMODE04
0x1C0 C8	PADCONFIG_50	Y1	SPI0_CLK	UART1_CT Sn	I2C2_SCL						GPIO0_53								

Table 6-106. Pin Multiplexing (continued)

ADDR ESS OFFSE T	REGISTER NAME	BALL NUMB ER	MUXMODE[15:0] SETTINGS															Bootstrap	
			0	1	2	3	4	5	6	7	8	9	10	11	12	13	14		
0x1C0 C8	WKUP_PADCON FIG_50	D14	MCU_SPI1 _D1	MCU_SPI1 _D1															MCU_BOO TMODE05
0x1C0 CC	WKUP_PADCON FIG_51	B21	MCU_SPI1 _CS0	MCU_SPI1 _CS0															
0x1C0 CC	PADCONFIG_51	V4	SPI0_D0	UART1_RT Sn	I2C2_SDA														
0x1C0 D0	WKUP_PADCON FIG_52	D13	MCU_MCA N1_TX	MCU_MCA N1_TX	MCU_SPI0 _CS3	MCU_ADC _EXT_TRI GGER0													
0x1C0 D0	PADCONFIG_52	T5	SPI0_D1																
0x1C0 D4	PADCONFIG_53	V3	I2C0_SCL																
0x1C0 D4	WKUP_PADCON FIG_53	B16	MCU_MCA N1_RX	MCU_MCA N1_RX	MCU_SPI1 _CS3	MCU_ADC _EXT_TRI GGER1													
0x1C0 D8	PADCONFIG_54	W2	I2C0_SDA																
0x1C0 D8	WKUP_PADCON FIG_54	C14	WKUP_UA RT0_CTSn	WKUP_UA RT0_CTSn	MCU_CPT S0_HW1T SPUSH	MCU_I2C1 _SCL													
0x1C0 DC	PADCONFIG_55	U3	ECAP0_IN _APWM_O UT	SYNC0_O UT	CPTS0_RF T_CLK	I2C1_SCL	CPTS0_H W1TSPUS H	UART3_RX D	SPI7_CS0	GPIO0_58									
0x1C0 DC	WKUP_PADCON FIG_55	C18	WKUP_UA RT0_RTSn	WKUP_UA RT0_RTSn	MCU_CPT S0_HW2T SPUSH	MCU_I2C1 _SDA													
0x1C0 E0	PADCONFIG_56	T3	EXT_REFC LK1	SYNC1_O UT		I2C1_SDA	CPTS0_H W2TSPUS H	UART3_TX D	SPI7_CLK	GPIO0_59									
0x1C0 E0	WKUP_PADCON FIG_56	C21	MCU_I2C1 _SCL	MCU_I2C1 _SCL	MCU_CPT S0_TS_SY NC	MCU_I3C0 _SCL	MCU_TIME R_IO6												
0x1C0 E4	PADCONFIG_57	V1	TIMER_IO 0	ECAP1_IN _APWM_O UT	SYSCLKO UT0			UART3_CT Sn	SPI7_D0	GPIO0_60	MMC1_SD CD								
0x1C0 E4	WKUP_PADCON FIG_57	C19	MCU_I2C1 _SDA	MCU_I2C1 _SDA	MCU_CPT S0_TS_CO MP	MCU_I3C0 _SDA	MCU_TIME R_IO7												
0x1C0 E8	PADCONFIG_58	W1	TIMER_IO 1	ECAP2_IN _APWM_O UT	OBSCLK0			UART3_RT Sn	SPI7_D1	GPIO0_61	MMC1_SD WP	PCIE1_CL KREQn							
0x1C0 E8	WKUP_PADCON FIG_58	C20	MCU_EXT _REFCLK0	MCU_EXT _REFCLK0	MCU_UAR T0_TXD	MCU_ADC _EXT_TRI GGER0	MCU_CPT S0_RFT_C LK	MCU_SYS CLKOUT0											
0x1C0 EC	WKUP_PADCON FIG_59	C16	MCU_OBS CLK0	MCU_OBS CLK0	MCU_UAR T0_RXD	MCU_ADC _EXT_TRI GGER1	MCU_TIME R_IO1	MCU_I3C0 _SDAPULL EN	MCU_CLK OUT0	WKUP_GP IO0_11									

Table 6-106. Pin Multiplexing (continued)

ADDRESS OFFSET	REGISTER NAME	BALL NUMBER	MUXMODE[15:0] SETTINGS														Bootstrap		
			0	1	2	3	4	5	6	7	8	9	10	11	12	13		14	
0x1C120	WKUP_PADCONFIG_72	D21					MCU_TIMER_IO6					WKUP_GPIO0_77							BOOTMODE04
0x1C120	PADCONFIG_72	T4	USB0_DRVVBUS									GPIO0_68							
0x1C124	WKUP_PADCONFIG_73	B15	TCK																
0x1C124	PADCONFIG_73	T19	PMIC_WAKE0n					RGMIID1				GPIO0_1							
0x1C128	WKUP_PADCONFIG_74	B20	TRSTn																
0x1C12C	WKUP_PADCONFIG_75	A13	EMU0																
0x1C130	WKUP_PADCONFIG_76	D12	EMU1																
0x1C134	WKUP_PADCONFIG_77	H17	MCU_ADC0_AIN0																
0x1C138	WKUP_PADCONFIG_78	K18	MCU_ADC0_AIN1																
0x1C13C	WKUP_PADCONFIG_79	M17	MCU_ADC0_AIN2																
0x1C140	WKUP_PADCONFIG_80	L18	MCU_ADC0_AIN3																
0x1C144	WKUP_PADCONFIG_81	J18	MCU_ADC0_AIN4																
0x1C148	WKUP_PADCONFIG_82	J17	MCU_ADC0_AIN5																
0x1C14C	WKUP_PADCONFIG_83	K17	MCU_ADC0_AIN6																
0x1C150	WKUP_PADCONFIG_84	L17	MCU_ADC0_AIN7																
0x1C164	PADCONFIG_89	V15	MCAN16_TX	RMII_REF_CLK				RGMIID1			GPIO0_45					UART7_TXD	GPMC0_A14		
0x1C168	PADCONFIG_90	U21	MCAN16_RX	CLKOUT				RGMIID0			GPIO0_46					UART7_RXD	GPMC0_CSn1	AUDIO_EX_T_REFCLK1	
0x1C174	WKUP_PADCONFIG_93	A15	RESET_REQz																
0x1C178	WKUP_PADCONFIG_94	H20	PORz																
0x1C17C	WKUP_PADCONFIG_95	E19						MCU_TIMER_IO7				WKUP_GPIO0_78							BOOTMODE05
0x1C180	WKUP_PADCONFIG_96	D18										WKUP_GPIO0_80							BOOTMODE06
0x1C184	WKUP_PADCONFIG_97	C17		WKUP_LF_CLKIN								WKUP_GPIO0_81							BOOTMODE07
0x1C188	WKUP_PADCONFIG_98	F19	TDI																

Table 6-106. Pin Multiplexing (continued)

ADDRESS OFFSET	REGISTER NAME	BALL NUMBER	MUXMODE[15:0] SETTINGS														Bootstrap	
			0	1	2	3	4	5	6	7	8	9	10	11	12	13		14
0x1C18C	WKUP_PADCON FIG_99	F21	TDO															
0x1C190	WKUP_PADCON FIG_100	E18	PMIC_WAKE1n	MCU_EXT_REFCLK0	MCU_CPT_S0_RFT_CLK					WKUP_GPIO_84								

6.5 Connections for Unused Pins

This section describes the Unused/Reserved balls connection requirements.

Note

All power balls must be supplied with the voltages specified in [Section 7.3, Recommended Operating Conditions](#), unless otherwise specified in [Section 6.3, Signal Descriptions](#).

Table 6-107. Unused Balls Specific Connection Requirements

BALL NUMBER	BALL NAME	CONNECTION REQUIREMENTS
V7	SERDES0_REXT	Each of these balls must be connected to VSS through a separate external pull resistor to ensure these balls are held to a valid logic low level if unused.
V5	USB0_RCALIB	
K19	OSC1_XI	
B20	TRSTN	
H17	MCU_ADC0_AIN0	
K18	MCU_ADC0_AIN1	
M17	MCU_ADC0_AIN2	
L18	MCU_ADC0_AIN3	
J18	MCU_ADC0_AIN4	
J17	MCU_ADC0_AIN5	
K17	MCU_ADC0_AIN6	
L17	MCU_ADC0_AIN7	
B2	DDR0_DQS0P	
E2	DDR0_DQS1P	
M2	DDR0_DQS2P	
R2	DDR0_DQS3P	
V1	MMC1_SDCD	
G15	VMON1_ER_VSYS	
D16	VMON2_IR_VCPU	
E17	VMON3_IR_VEXT1P8	
F17	VMON4_IR_VEXT1P8	
L14	VMON5_IR_VEXT3P3	

Table 6-107. Unused Balls Specific Connection Requirements (continued)

BALL NUMBER	BALL NAME	CONNECTION REQUIREMENTS
A18	MCU_RESETZ	Each of these balls must be connected to the corresponding power supply through a separate external pull resistor to ensure these balls are held to a valid logic high level if unused. ⁽¹⁾
G19	MCU_PORZ	
H20	PORZ	
B15	TCK	
U4	TMS	
F20	WKUP_I2C0_SCL	
H21	WKUP_I2C0_SDA	
G20	MCU_I2C0_SDA	
G21	MCU_I2C0_SCL	
W2	I2C0_SDA	
V3	I2C0_SCL	
U6	EXTINTN	
F19	TDI	
F21	TDO	
D12	EMU1	
A13	EMU0	
B1	DDR0_DQS0N	
E1	DDR0_DQS1N	
M1	DDR0_DQS2N	
R1	DDR0_DQS3N	
N17	VPP_CORE	Each of these balls must be left unconnected if unused.
E11	VPP_MCU	
P20	MMC0_CALPAD	
AA8	SERDES0_REFCLK_N	
AA9	SERDES0_REFCLK_P	
AA11	SERDES0_RX0_N	
AA12	SERDES0_RX0_P	
W11	SERDES0_TX0_N	
W12	SERDES0_TX0_P	
W8	SERDES0_RX1_N	
W9	SERDES0_RX1_P	
Y10	SERDES0_TX1_N	
Y11	SERDES0_TX1_P	
Y7	SERDES0_RX2_N	
Y8	SERDES0_RX2_P	
AA5	SERDES0_TX2_N	
AA6	SERDES0_TX2_P	
W5	SERDES0_RX3_N	
W6	SERDES0_RX3_P	
Y4	SERDES0_TX3_N	
Y5	SERDES0_TX3_P	

(1) To determine which power supply is associated with any IO refer to [Table 6-1, Pin Attributes](#).

Table 6-108. Reserved Balls Specific Connection Requirements

BALLS	CONNECTION REQUIREMENTS
A21 / AA21 / K8 / K9 / K10 / L8 / L9 / L10	These balls do not exist on the package.

Table 6-108. Reserved Balls Specific Connection Requirements (continued)

BALLS	CONNECTION REQUIREMENTS
H18 / F18 / N18 / L20 / K20 / J20 / V8 / V10 / E5 / F6	These balls must be left unconnected.

Note

All other unused signal balls **without** Pad Configuration Register can be left unconnected.

Note

All other unused signal balls **with** a Pad Configuration Register can be left unconnected with their multiplexing mode set to GPIO input and internal pulldown resistor enabled.

Unused balls are defined as those which only connect to a PCB solder pad. This is the only use case where internal pull resistors are allowed as the only source/sink to hold a valid logic level.

Any balls connected to a via, test point, or PCB trace are considered used and must not depend on the internal pull resistor to hold a valid logic level.

Internal pull resistors are weak and may not source enough current to maintain a valid logic level for some operating conditions. This may be the case when connected to components with leakage to the opposite logic level, or when external noise sources couple to signal traces attached to balls which are only pulled to a valid logic level by the internal resistor. Therefore, external pull resistors may be required to hold a valid logic level on balls with external connections.

If balls are allowed to float between valid logic levels, the input buffer may enter a high-current state which could damage the IO cell.

7 Specifications

7.1 Absolute Maximum Ratings

over operating free-air temperature range (unless otherwise noted)^{(1) (2)}

PARAMETER		MIN	MAX	UNIT
VDD_CORE	MAIN domain core supply	-0.3	1.05	V
VDD_MCU	MCUSS core supply	-0.3	1.05	V
VDD_CPU	CPU core supply	-0.3	1.05	V
VDD_MCU_WAKE1	Core supply for MCU WAKE function	-0.3	1.05	V
VDD_WAKE0	Core supply for MAIN domain WAKE function which includes all "CANUART" IO.	-0.3	1.05	V
VDDA_0P8_DLL_MMC0	MMC0 DLL analog supply	-0.3	1.05	V
VDDAR_CORE	MAIN domain RAM supply	-0.3	1.05	V
VDDAR_MCU	MCUSS RAM supply	-0.3	1.05	V
VDDAR_CPU	CPU RAM supply	-0.3	1.05	V
VDDA_0P8_SERDES0	SERDES0 analog supply low	-0.3	1.05	V
VDDA_0P8_SERDES0_C	SERDES0 clock supply	-0.3	1.05	V
VDDA_0P8_USB	USB0 0.8 V analog supply	-0.3	1.05	V
VDDA_0P8_PLL_DDR	DDR PLL analog supply	-0.3	1.05	V
VDDA_1P8_USB	USB0 1.8 V analog supply	-0.3	2.2	V
VDDA_1P8_SERDES0	SERDES0 analog supply high	-0.3	2.2	V
VDDA_3P3_USB	USB0 3.3 V analog supply	-0.3	3.8	V
VDDA_MCU_PLLGRP0	Analog supply for MCU PLL Group 0	-0.3	2.2	V
VDDA_PLLGRP0	Analog supply for MAIN PLL Group 0	-0.3	2.2	V
VDDA_PLLGRP4	Analog supply for MAIN PLL Group 4	-0.3	2.2	V
VDDA_PLLGRP6	Analog supply for MAIN PLL Group 6	-0.3	2.2	V
VDDA_PLLGRP8	Analog supply for MAIN PLL Group 8	-0.3	2.2	V
VDDA_WKUP	Oscillator supply for WKUP domain	-0.3	2.2	V
VDDA_ADC_MCU	ADC analog supply	-0.3	2.2	V
VDDA_MCU_TEMP	Analog supply for temperature sensor 0 in MCU domain	-0.3	2.2	V
VDDA_POR_WKUP	WKUP domain analog supply	-0.3	2.2	V
VDDA_TEMP0	Analog supply for temperature sensor 0	-0.3	2.2	V
VDDA_TEMP1	Analog supply for temperature sensor 1	-0.3	2.2	V
VDDS_DDR ⁽¹⁰⁾	DDR interface power supply	-0.3	1.2	V
VDDS_DDR_BIAS ⁽¹⁰⁾	Bias supply for LPDDR4	-0.3	1.2	V
VDDS_DDR_C ⁽¹⁰⁾	IO power for DDR Memory Clock Bit (MCB) macro	-0.3	1.2	V
VDDS_MMC0	MMC0 IO supply	-0.3	2.2	V
VDDA_OSC1	HFOSC1 supply	-0.3	2.2	V
VDDSHV0_MCU	IO supply MCUSS general IO group, and MCU and MAIN domain warm reset pins	-0.3	3.8	V
VDDSHV0	IO supply for MAIN domain general	-0.3	3.8	V
VDDSHV1_MCU	IO supply for MCUSS IO group 1	-0.3	3.8	V
VDDSHV2_MCU	IO supply for MCUSS IO group 2	-0.3	3.8	V
VDDSHV2	IO supply for MAIN domain IO group 2	-0.3	3.8	V
VDDSHV5	IO supply for MAIN domain IO group 5	-0.3	3.8	V
VPP_CORE	Supply voltage range for CORE EFUSE domain	-0.3	1.89	V
VPP_MCU	Supply voltage range for MCU EFUSE domain	-0.3	1.89	V
USB0_VBUS ⁽⁹⁾	Voltage range for USB VBUS comparator input	-0.3	3.6	V

7.1 Absolute Maximum Ratings (continued)

over operating free-air temperature range (unless otherwise noted)⁽¹⁾ ⁽²⁾

	PARAMETER	MIN	MAX	UNIT
Steady State Max. Voltage at all fail-safe IO pins	I2C0_SCL, I2C0_SDA, WKUP_I2C0_SCL, WKUP_I2C0_SDA, MCU_I2C0_SCL, MCU_I2C0_SDA, EXTINTn	-0.3	3.8	V
	MCU_PORz, PORz	-0.3	3.8	V
	VMON2_IR_VCPU	-0.3	1.05	V
	VMON3_IR_VEXT1P8, VMON4_IR_VEXT1P8, VMON1_ER_VSYS ⁽⁸⁾	-0.3	2.2	V
	VMON5_IR_VEXT3P3	-0.3	3.8	V
Steady State Max. Voltage at all other IO pins ⁽³⁾	All other IO pins	-0.3	IO supply voltage + 0.3	V
Transient Overshoot and Undershoot specification at IO pin	20% of IO supply voltage for up to 20% of signal period (see Figure 7-1, IO Transient Voltage Ranges)		0.2 × VDD ⁽⁶⁾	V
Latch-up Performance, Class II (125°C) ⁽⁴⁾	I-Test	-100	100	mA
	Over-Voltage (OV) Test	NA	1.5 × VDD ⁽⁷⁾	V
T _{STG} ⁽⁵⁾	Storage temperature	-55	+150	°C

- (1) Operation outside the Absolute Maximum Ratings may cause permanent device damage. Absolute Maximum Ratings do not imply functional operation of the device at these or any other conditions beyond those listed under Recommended Operating Conditions. If used outside the [Section 7.3, Recommended Operating Conditions](#) but within the Absolute Maximum Ratings, the device may not be fully functional, and this may affect device reliability, functionality, performance, and shorten the device lifetime.
- (2) All voltage values are with respect to their associated VSS or VSSA_x, unless otherwise noted.
- (3) This parameter applies to all IO pins which are not fail-safe and the requirement applies to all values of IO supply voltage. For example, if the voltage applied to a specific IO supply is 0 volts the valid input voltage range for any IO powered by that supply will be -0.3 to +0.3 volts. Special attention should be applied anytime peripheral devices are not powered from the same power sources used to power the respective IO supply. It is important the attached peripheral never sources a voltage outside the valid input voltage range, including power supply ramp-up and ramp-down sequences.
- (4) For current pulse injection:
Pins stressed per JEDEC JESD78E (Class II) and passed with specified I/O pin injection current and clamp voltage of 1.5 times maximum recommended I/O voltage and negative 0.5 times maximum recommended I/O voltage.
For overvoltage performance:
Supplies stressed per JEDEC JESD78E (Class II) and passed specified voltage injection.
- (5) For tape and reel the storage temperature range is [-10°C; +50°C] with a maximum relative humidity of 70%. TI recommends returning to ambient room temperature before usage.
- (6) VDD is the voltage on the corresponding power-supply pin(s) for the IO.
- (7) An external resistor divider is required to create the VMON input value that triggers with V_{TH} = 0.45 when the V_{SYS} level reaches the minimum allowed threshold. A series resistor R2 (VMON_ER_VSYS = V_{SYS} × R1 / (R1 + R2)) of at least 10kΩ is recommended to limit current.
- (8) The VMON1_ER_VSYS pin provides a way to monitor the system power supply. For more information, see [Section 9.3.4 System Power Supply Monitor Design Guidelines](#).
- (9) An external resistor divider is required to limit the voltage applied to this device pin. For more information, see [Section 9.3.3, USB VBUS Design Guidelines](#).
- (10) A single 1.1V source must drive all three VDDS_DDR, VDDS_DDR_BIAS, VDDS_DDR_C supplies.

Fail-safe IO terminals are designed such they do not have dependencies on the respective IO power supply voltage. This allows external voltage sources to be connected to these IO terminals when the respective IO power supplies are turned off. The I2C0_SCL, I2C0_SDA, WKUP_I2C0_SCL, WKUP_I2C0_SDA, MCU_I2C0_SCL, MCU_I2C0_SDA, EXTINTn, MCU_PORz, PORz, VMON1_ER_VSYS, VMON2_IR_VCPU, VMON3_IR_VEXT1P8, VMON4_IR_VEXT1P8, VMON5_ER_VEXT3P3 are the only fail-safe IO terminals. All other IO terminals are not fail-safe and the voltage applied to them should be limited to the value defined by the Steady State Max. Voltage at all IO pins parameter in [Section 7.1](#).

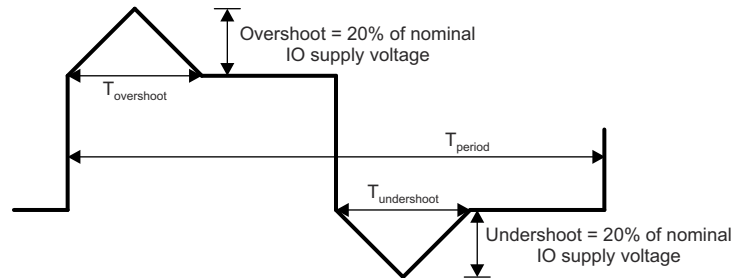

A. $T_{overshoot} + T_{undershoot} < 20\%$ of T_{period}

Figure 7-1. IO Transient Voltage Ranges

7.2 ESD Ratings

			VALUE	UNIT	
V _(ESD)	Electrostatic discharge	Human-body model (HBM), per AEC Q100-002 ⁽¹⁾	±1000	V	
		Charged-device model (CDM), per AEC Q100-011	All pins		±250
			Corner pins (A1, AJ29)		±750

(1) AEC Q100-002 indicates that HBM stressing shall be in accordance with the ANSI/ESDA/JEDEC JS-001 specification.

7.3 Recommended Operating Conditions

over operating free-air temperature range (unless otherwise noted)

SUPPLY NAME	DESCRIPTION	MIN ⁽¹⁾	NOM	MAX ⁽¹⁾	UNIT
VDD_CORE ⁽³⁾	Boot/Active voltage for MAIN domain core supply	0.76 ⁽¹⁾	0.8	0.84 ⁽¹⁾	V
VDD_MCU	Boot/Active voltage for MCUSS core supply	0.76 ⁽¹⁾	0.8	0.89 ⁽¹⁾	V
VDD_CPU	Boot voltage for CPU core supply, applied at cold power up event	0.76 ⁽¹⁾	0.8	0.84 ⁽¹⁾	V
	Active voltage for CPU core supply, after AVS mode enabled in software	AVS ⁽⁵⁾ -5% (1)	AVS ⁽⁵⁾	AVS ⁽⁵⁾ +5% (1)	V
VDD_CPU AVS Range	Efuse valid voltage range for VDD_CPU voltage	0.6		0.9	V
VDD_MCU_WAKE1	Core supply for MCU WAKE function	0.76	0.8	0.89	V
VDD_WAKE0	Core supply for MAIN domain WAKE function which includes all "CANUART" IO.	0.76	0.8	0.89	V
VDDA_0P8_DLL_MMC0	MMC PLL analog supply	0.76	0.8	0.84	V
VDDAR_CORE	Main domain RAM supply	0.81	0.85	0.89	V
VDDAR_MCU	MCUSS RAM supply	0.81	0.85	0.89	V
VDDAR_CPU	CPU RAM supply	0.81	0.85	0.89	V
VDDA_0P8_SERDES0 ⁽³⁾	SERDES0 analog supply low	0.76	0.8	0.84	V
VDDA_0P8_SERDES0_C ⁽³⁾	SERDES0-1 clock supply	0.76	0.8	0.84	V
VDDA_0P8_USB ⁽³⁾	USB 0.8v analog supply	0.76	0.8	0.84	V
VDDA_1P8_USB	USB 1.8v analog supply	1.71	1.8	1.89	V
VDDA_1P8_SERDES0	SERDES0 analog supply high	1.71	1.8	1.89	V
VDDA_3P3_USB	USB 3.3v analog supply	3.14	3.3	3.46	V

7.3 Recommended Operating Conditions (continued)

over operating free-air temperature range (unless otherwise noted)

SUPPLY NAME	DESCRIPTION		MIN ⁽¹⁾	NOM	MAX ⁽¹⁾	UNIT
VDDA_MCU_PLLGRP0	Analog supply for MCU PLL Group 0		1.71	1.8	1.89	V
VDDA_PLLGRP0	Analog supply for MAIN PLL Group 0		1.71	1.8	1.89	V
VDDA_PLLGRP4	Analog supply for MAIN PLL Group 4		1.71	1.8	1.89	V
VDDA_PLLGRP6	Analog supply for MAIN PLL Group 6		1.71	1.8	1.89	V
VDDA_PLLGRP8	Analog supply for MAIN PLL Group 8		1.71	1.8	1.89	V
VDDA_WKUP	Oscillator supply for WKUP domain		1.71	1.8	1.89	V
VDDA_ADC_MCU	ADC analog supply		1.71	1.8	1.89	V
VDDA_0P8_PLL_DDR	DDR PLL analog supply		0.76	0.8	0.84	V
VDDA_MCU_TEMP	Analog supply for temperature sensor 0 in MCU domain		1.71	1.8	1.89	V
VDDA_POR_WKUP	WKUP domain analog supply		1.71	1.8	1.89	V
VDDA_TEMP0	Analog supply for temperature sensor 0		1.71	1.8	1.89	V
VDDA_TEMP1	Analog supply for temperature sensor 1		1.71	1.8	1.89	V
VDDS_DDR ⁽²⁾	DDR interface power supply		1.05	1.1	1.15	V
VDDS_DDR_BIAS ⁽²⁾	Bias supply for LPDDR4		1.05	1.1	1.15	V
VDDS_DDR_C ⁽²⁾	IO power for DDR Memory Clock Bit (MCB) macro		1.05	1.1	1.15	V
VDDS_MMC0	MMC0 IO supply		1.71	1.8	1.89	V
VDDA_OSC1	HFOSC1 supply		1.71	1.8	1.89	V
VDDA_*	Peak to Peak Noise for all VDDA inputs				25	mV
VDDSHV0	IO supply for main domain general	1.8-V operation	1.71	1.8	1.89	V
		3.3-V operation	3.14	3.3	3.46	V
VDDSHV0_MCU	IO supply MCUSS general IO group, and MCU and Main domain warm reset pins	1.8-V operation	1.71	1.8	1.89	V
		3.3-V operation	3.14	3.3	3.46	V
VDDSHV1_MCU	IO supply for MCUSS IO group 1	1.8-V operation	1.71	1.8	1.89	V
		3.3-V operation	3.14	3.3	3.46	V
VDDSHV2	IO supply for main domain IO group 2	1.8-V operation	1.71	1.8	1.89	V
		3.3-V operation	3.14	3.3	3.46	V
VDDSHV2_MCU	IO supply for MCUSS IO group 2	1.8-V operation	1.71	1.8	1.89	V
		3.3-V operation	3.14	3.3	3.46	V
VDDSHV5	IO supply for main domain IO group 5	1.8-V operation	1.71	1.8	1.89	V
		3.3-V operation	3.14	3.3	3.46	V
USB0_VBUS	Voltage range for USB VBUS comparator input		0	See ⁽⁶⁾	3.46	V
USB0_ID	Voltage range for the USB ID input			See ⁽⁴⁾		V
VSS	Ground			0		V
T _J	Operating junction temperature range	Automotive	-40		125	°C
		Extended	-40		105	°C
		Commercial	0		90	°C

- (1) For all VDD* supply inputs, the voltage at the device ball must never be below the MIN voltage or above the MAX voltage for any amount of time. This requirement includes dynamic voltage events such as AC ripple, voltage transients, voltage dips, and so forth. This is required for all supply inputs, but special care should be given to the VDD_CORE, VDD_MCU, and VDD_CPU domains which have higher transient current demand compared to other rails.
- (2) A single 1.1-V source must drive all three VDDS_DDR, VDDS_DDR_BIAS, VDDS_DDR_C supplies. These supplies are required to still be powered with LPDDR4 voltage ranges, even if DDR interface is unused.
- (3) A single 0.8-V source must drive the VDD_CORE and VDDA_0P8_PHY input supplies. Also, include Analog filter components on the individual VDDA_0P8_PHY input supplies for interfaces that are used in the system.
- (4) This terminal is connected to analog circuits in the respective USB PHY. The circuit sources a known current while measuring the voltage to determine if the terminal is connected to VSS with a resistance less than 10 Ω or greater than 100 kΩ. The terminal should

be connected to ground for USB host operation or open-circuit for USB peripheral operation, and should never be connected to any external voltage source.

- (5) The AVS Voltages are device-dependent, voltage domain-dependent, and OPP-dependent. They must be read from the VTM_DEVINFO_VDn. For information about VTM_DEVINFO_VDn Registers address, please refer to Voltage and Thermal Manager section in the device TRM. The power supply should be adjustable over the ranges shown in the VDD_CPU AVS Range entry.
- (6) An external resistor divider is required to limit the voltage applied to this device pin. For more information, see [Section 9.3.3, USB VBUS Design Guidelines](#)

7.4 Power-On-Hours (POH)

IP ^{1 2 3}	VOLTAGE DOMAIN	VOLTAGE (V) (MAX)	FREQUENCY (MHz) (MAX)	T _J (°C)	POH
All	100%	All	All Supported OPPs	Automotive -40°C to 125°C	20000
All	100%	All	All Supported OPPs	Extended -40°C to 105°C	100000
All	100%	All	All Supported OPPs	Commercial 0°C to 90°C	100000

1. This information is provided solely for your convenience and does not extend or modify the warranty provided under TI's standard terms and conditions for TI semiconductor products.
2. Unless specified in the table above, all voltage domains and operating conditions are supported in the device at the noted temperatures.
3. POH is a function of voltage, temperature and time. Usage at higher voltages and temperatures will result in a reduction in POH.
4. Automotive profile is defined as 20000 power on hours with a junction temperature as follows: 5%@-40°C, 65%@70°C, 20%@110°C, and 10%@125°C.

7.5 Operating Performance Points

This section describes the maximum operating conditions of the device in [Table 7-1](#). This section also contains the description of each Operating Performance Point (OPP) for processor clocks and device core clocks in [Table 7-2](#).

Table 7-1. Speed Grade Maximum Frequency

DEVICE	MAXIMUM FREQUENCY (MHz)					
	A72SS0	R5FSS0	MCU_R5FSS0	CBASS0	DMSC	LPDDR4 ⁽¹⁾
DRA821xT	2000	1000	1000	500	333	1600 (DDR-3200)
DRA821xL	1500	1000	1000	500	333	1600 (DDR-3200)
DRA821xE	1000	1000	1000	500	333	1600 (DDR-3200)
DRA821xC	750	500	1000	500	333	1600 (DDR-3200)

- (1) Maximum DDR Frequency will be limited based on the specific memory type (vendor) used in a system and by PCB implementation. TI strongly recommends all designs to follow the TI LPDDR4 EVM PCB layout exactly in every detail (routing, spacing, vias/backdrill, PCB material, etc.) in order to achieve the full specified clock frequency. Refer to the [Jacinto 7 DDR Board Design and Layout Guidelines](#) for details.

Table 7-2. Supported OPP vs Max Frequency

see (1) (2)

CLOCK	MAXIMUM FREQUENCY(MHz)	
	OPP_LOW ⁽⁴⁾	OPP_NOM ⁽³⁾
MPU_CLK (A72SS0)	1000	2000
MSMC_CLK	500	1000
DDRn_CLKP/DDRn_CKN	1066 (2133 MT/s) or 1333 (2666 MT/s) ⁽⁵⁾	1600 (3200 MT/s)

- (1) OPP and VDD_CPU voltage should be selected/set at boot time. DVFS is *not* supported.
- (2) Frequency must be limited based on the lower frequency constraint from this table and [Speed Grade Maximum Frequency](#). For example, the T speed grade can operate A72SS/MSMC at 2 GHz/1GHz or 1 GHz/500 MHz. A72SS/MSMC at 2 GHz/1GHz operation must use OPP_NOM. A72SS/MSMC at 1 GHz/500 MHz operation can use OPP_NOM or OPP_LOW voltage. Similarly, the E speed grade can operate A72SS/MSMC at a maximum of 1 GHz/500 MHz. In this case, OPP_NOM or OPP_LOW voltage is allowed (though OPP_LOW voltage is recommended to reduce power consumption).
- (3) OPP_NOM AVS voltage for VDD_CPU should be set based on the OPP_1 register setting.
- (4) If OPP_0 is not equal to 0, OPP_LOW AVS voltage for VDD_CPU should be set based on the OPP_0 register setting. If OPP_0 is equal to 0, OPP_1 register setting should be used.
- (5) DDR can be configured for up to 2666 MT/s in OPP_LOW. 2132 MT/s is recommended in OPP_LOW as it more closely matches the MPU_CLK scaling and also saves power compared to 2666 MT/s.

7.6 Electrical Characteristics

Note

The interfaces or signals described in [Section 7.6.10](#) through [Section 7.6.10](#) correspond to the interfaces or signals available in multiplexing mode 0 (Primary Function).

All interfaces or signals multiplexed on the balls described in these tables have the same DC electrical characteristics, unless multiplexing involves a PHY and GPIO combination, in which case different DC electrical characteristics are specified for the different multiplexing modes (Functions).

7.6.1 I2C, Open-Drain, Fail-Safe (I2C OD FS) Electrical Characteristics

over recommended operating conditions (unless otherwise noted)⁽¹⁾

PARAMETER		TEST CONDITIONS	MIN	TYP	MAX	UNIT
BALL NAMES in Mode 0: WKUP_I2C0_SDA, WKUP_I2C0_SCL, MCU_I2C0_SDA, MCU_I2C0_SCL, I2C0_SDA, I2C0_SCL, EXTINTN						
BALL NUMBERS: H21 / F20 / G20 / G21 / W2 / V3 / U6						
1.8 V MODE						
V _{IL}	Input Low Voltage				0.3 × VDDSHV ⁽¹⁾	V
V _{ILSS}	Input Low Voltage Steady State				0.3 × VDDSHV ⁽¹⁾	V
V _{IH}	Input High Voltage		0.7 × VDDSHV ⁽¹⁾			V
V _{IHSS}	Input High Voltage Steady State		0.7 × VDDSHV ⁽¹⁾			V
V _{HYS}	Input Hysteresis Voltage		0.1 × VDDSHV ⁽¹⁾			mV
I _{IN}	Input Leakage Current.	V _I = 1.8 V or 0 V			±10	µA
V _{OL}	Output Low Voltage				0.2 × VDDSHV ⁽¹⁾	V
I _{OL}	Low Level Output Current	V _{OL(MAX)}	10			mA
3.3 V MODE ⁽²⁾						
V _{IL}	Input Low Voltage				0.3 × VDDSHV ⁽¹⁾	V
V _{ILSS}	Input Low Voltage Steady State				0.25 × VDDSHV ⁽¹⁾	V
V _{IH}	Input High Voltage		0.7 × VDDSHV ⁽¹⁾			V
V _{IHSS}	Input High Voltage Steady State		0.7 × VDDSHV ⁽¹⁾			V
V _{HYS}	Input Hysteresis Voltage		0.05 × VDDSHV ⁽¹⁾			mV
I _{IN}	Input Leakage Current.	V _I = 3.3 V or 0 V			±10	µA
V _{OL}	Output Low Voltage				0.4	V
I _{OL}	Low Level Output Current	V _{OL(MAX)}	10			mA

(1) VDDSHV stands for corresponding power supply. For more information on the power supply name and the corresponding ball, see [Table 6-1](#), POWER column.

(2) I2C HS-mode is not supported when operating the IO in 3.3 V mode.

7.6.2 Fail-Safe Reset (FS Reset) Electrical Characteristics

Over recommended operating conditions (unless otherwise noted)

PARAMETER	TEST CONDITIONS	MIN	TYP	MAX	UNIT
BALL NAMES in Mode 0: MCU_PORz, PORz					

Over recommended operating conditions (unless otherwise noted)

PARAMETER		TEST CONDITIONS	MIN	TYP	MAX	UNIT
BALL NUMBERS: G19 / H20						
V _{IL}	Input low-level threshold				0.3 × VDDSHV ⁽¹⁾	V
V _{ILSS}	Input low-level threshold steady state				0.3 × VDDSHV ⁽¹⁾	V
V _{IH}	Input high-level threshold		0.7 × VDDSHV ⁽¹⁾			V
V _{IHSS}	Input high-level threshold steady state		0.7 × VDDSHV ⁽¹⁾			V
V _{HYS}	Input Hysteresis Voltage		200			mV
I _{IN}	Input Leakage Current	V _I = 1.8 V or 0 V			±10	μA

(1) VDDSHV stands for corresponding power supply. For more information on the power supply name and the corresponding ball, see [Pin Attributes](#), POWER column.

7.6.3 HFOSC Electrical Characteristics

over recommended operating conditions (unless otherwise noted)

PARAMETER		TEST CONDITIONS	MIN	TYP	MAX	UNIT
HIGH FREQUENCY OSCILLATOR						
BALL NAMES: OSC1_XI, WKUP_OSC0_XI						
BALL NUMBERS: K19 / K21						
V _{IH}	High-level input voltage		0.65 × VDDSHV ⁽¹⁾			V
V _{IL}	Low-level input voltage				0.35 × VDDSHV ⁽¹⁾	V
V _{HYS}	Input Hysteresis Voltage			49		mV

(1) VDDSHV stands for corresponding power supply. For more information on the power supply name and the corresponding ball, see [Table 6-1](#), POWER column.

7.6.4 eMMCPHY Electrical Characteristics

over operating free-air temperature range (unless otherwise noted)

PARAMETER		TEST CONDITIONS	MIN	TYP	MAX	UNIT
BALL NAMES in Mode 0: MMC0_DAT[7:0], MMC0_CALPAD, MMC0_CMD, MMC0_DS, MMC0_CLK						
BALL NUMBERS: R16 / P17 / R18 / R20 / R19 / P16 / R21 / T21 / P20 / R17 / P19 / P18						
V _{IL}	Input Low Voltage				0.35 × VDDSHV ⁽¹⁾	V
V _{ILSS}	Input Low Voltage Steady State				0.20	V
V _{IH}	Input High Voltage		0.65 × VDDSHV ⁽¹⁾			V
V _{IHSS}	Input High Voltage Steady State		1.4			V
I _{IN}	Input Leakage Current.	V _I = 1.8 V or 0 V			±10	μA
I _{OZ}	Tri-state Output Leakage Current.	V _O = 1.8 V or 0 V			±10	μA
R _{PU}	Pull-up Resistor		15	20	25	kΩ
R _{PD}	Pull-down Resistor		15	20	25	kΩ
V _{OL}	Output Low Voltage				0.30	V
V _{OH}	Output High Voltage		VDDSHV ⁽¹⁾ - 0.30			V
I _{OL}	Low Level Output Current	V _{OL(MAX)}	2			mA
I _{OH}	High Level Output Current	V _{OH(MIN)}	2			mA

over operating free-air temperature range (unless otherwise noted)

PARAMETER	TEST CONDITIONS	MIN	TYP	MAX	UNIT
SR _I	Input Slew Rate	5E+8			V/s

- (1) VDDSHV stands for corresponding power supply. For more information on the power supply name and the corresponding ball, see [Table 6-1](#), POWER column.

7.6.5 SDIO Electrical Characteristics

over operating free-air temperature range (unless otherwise noted)

PARAMETER	TEST CONDITIONS	MIN	TYP	MAX	UNIT
BALL NAMES in Mode 0: MMC1_CLK, MMC1_CMD, MMC1_DAT[3:0]					
BALL NUMBERS: P21 / M20 / M19 / N21 / N20 / N19					
1.8 V MODE					
V _{IL}	Input Low Voltage			0.58	V
V _{ILSS}	Input Low Voltage Steady State			0.58	V
V _{IH}	Input High Voltage	1.27			V
V _{IHSS}	Input High Voltage Steady State	1.7			V
V _{HYS}	Input Hysteresis Voltage	150			mV
I _{IN}	Input Leakage Current.	V _I = 1.8 V or 0 V		±10	µA
R _{PU}	Pull-up Resistor	40	50	60	kΩ
R _{PD}	Pull-down Resistor	40	50	60	kΩ
V _{OL}	Output Low Voltage			0.45	V
V _{OH}	Output High Voltage	VDDSHV ⁽¹⁾ - 0.45			V
I _{OL}	Low Level Output Current	V _{OL(MAX)}	4		mA
I _{OH}	High Level Output Current	V _{OH(MIN)}	4		mA
3.3 V MODE					
V _{IL}	Input Low Voltage			0.25 × VDDSHV ⁽¹⁾	V
V _{ILSS}	Input Low Voltage Steady State			0.15 × VDDSHV ⁽¹⁾	V
V _{IH}	Input High Voltage	0.625 × VDDSHV ⁽¹⁾			V
V _{IHSS}	Input High Voltage Steady State	0.625 × VDDSHV ⁽¹⁾			V
V _{HYS}	Input Hysteresis Voltage	150			mV
I _{IN}	Input Leakage Current.	V _I = 1.8 V or 0 V		±10	µA
R _{PU}	Pull-up Resistor	40	50	60	kΩ
R _{PD}	Pull-down Resistor	40	50	60	kΩ
V _{OL}	Output Low Voltage			0.125 × VDDSHV ⁽¹⁾	V
V _{OH}	Output High Voltage	0.75 × VDDSHV ⁽¹⁾			V
I _{OL}	Low Level Output Current	V _{OL(MAX)}	6		mA
I _{OH}	High Level Output Current	V _{OH(MIN)}	10		mA

- (1) VDDSHV stands for corresponding power supply. For more information on the power supply name and the corresponding ball, see [Table 6-1](#), POWER column.

7.6.6 ADC12BT Electrical Characteristics

over recommended operating conditions (unless otherwise noted)

PARAMETER	TEST CONDITIONS	MIN	TYP	MAX	UNIT
BALL NAMES in Mode 0: MCU_ADC0_AIN[7:0]					
BALL NUMBERS: J18 / H17 / K18 / J17 / M17 / K17 / L18 / L17					
V _{MCU_ADC0_AIN[7:0]}	Full-scale Input Range		VSS	VDDA ⁽²⁾	V
DNL	Differential Non-Linearity	-1	0.5	4	LSB
INL	Integral Non-Linearity		±1	±4	LSB
LSB _{GAIN-ERROR}	Gain Error		±2		LSB
LSB _{OFFSET-ERROR}	Offset Error		±2		LSB
C _{IN}	Input Sampling Capacitance		5.5		pF
SNR	Signal-to-Noise Ratio	Input Signal: 200 kHz sine wave at -0.5 dB Full Scale	70		dB
THD	Total Harmonic Distortion	Input Signal: 200 kHz sine wave at -0.5 dB Full Scale	75		dB
SFDR	Spurious Free Dynamic Range	Input Signal: 200 kHz sine wave at -0.5 dB Full Scale	80		dB
SNR _(PLUS)	Signal-to-Noise Plus Distortion	Input Signal: 200 kHz sine wave at -0.5 dB Full Scale	69		dB
R _{MCU_ADC0_AIN[0:7]}	Input Impedance of MCU_ADC0_AIN[7:0]	f = input frequency	[1/((65.97 × 10 ⁻¹²) × f _{SMPL_CLK})]		Ω
I _{IN}	Input Leakage	MCU_ADC0_AIN[7:0] = VSS		5	μA
		MCU_ADC0_AIN[7:0] = VDDA_ADC_MCU		10	μA
Sampling Dynamics					
F _{SMPL_CLK}	SMPL_CLK Frequency		60		MHz
t _C	Conversion Time		13		ADC0 SMPL_CLK Cycles
t _{ACQ}	Acquisition time		2	257	ADC0 SMPL_CLK Cycles
T _R	Sampling Rate	ADC0 SMPL_CLK = 60 MHz		4	MSPS
CCISO	Channel to Channel Isolation		100		dB
General Purpose Input Mode⁽¹⁾					
V _{IL}	Input Low Voltage			0.35 × VDDA ⁽²⁾	V
V _{ILSS}	Input Low Voltage Steady State			0.35 × VDDA ⁽²⁾	V
V _{IH}	Input High Voltage		0.65 × VDDA ⁽²⁾		V
V _{IHSS}	Input High Voltage Steady State		0.65 × VDDA ⁽²⁾		V

over recommended operating conditions (unless otherwise noted)

PARAMETER		TEST CONDITIONS	MIN	TYP	MAX	UNIT
V _{HYS}	Input Hysteresis Voltage		200			mV
I _I	Input Leakage Current	V _I = 1.8 V or 0 V			2	μA

- (1) MCU_ADC0 can be configured to operate in General Purpose Input mode, where all MCU_ADC0_AIN[7:0] inputs are globally enabled to operate as digital inputs via the ADC0_CTRL register (gpi_mode_en = 1).
- (2) VDDA stands for corresponding power supply. For more information on the power supply name and the corresponding ball, see [Table 6-1](#), POWER column.

7.6.7 LVC MOS Electrical Characteristics

Over recommended operating conditions (unless otherwise noted)

PARAMETER		TEST CONDITIONS	MIN	TYP	MAX	UNIT
BALL NAMES: ALL other IOs						
BALL NUMBERS: ALL other IOs						
1.8-V MODE						
V _{IL}	Input Low Voltage			0.35 × VDD ⁽¹⁾		V
V _{ILSS}	Input Low Voltage Steady State			0.3 × VDD ⁽¹⁾		V
V _{IH}	Input High Voltage		0.65 × VDD ⁽¹⁾			V
V _{IHSS}	Input High Voltage Steady State		0.85 × VDD ⁽¹⁾			V
V _{HYS}	Input Hysteresis Voltage		150			mV
I _{IN}	Input Leakage Current.	V _I = 1.8 V or 0 V			±10	μA
R _{PU}	Pull-up Resistor		15	22	30	kΩ
R _{PD}	Pull-down Resistor		15	22	30	kΩ
V _{OL}	Output Low Voltage				0.45	V
V _{OH}	Output High Voltage		VDD ⁽¹⁾ - 0.45			V
I _{OL}	Low Level Output Current	V _{OL(MAX)}	3			mA
I _{OH}	High Level Output Current	V _{OH(MIN)}	3			mA
3.3-V MODE						
V _{IL}	Input Low Voltage				0.8	V
V _{ILSS}	Input Low Voltage Steady State				0.6	V
V _{IH}	Input High Voltage		2.0			V
V _{IHSS}	Input High Voltage Steady State		2.0			V
V _{HYS}	Input Hysteresis Voltage		150			mV
I _{IN}	Input Leakage Current.	V _I = 3.3 V or 0 V			±10	μA
R _{PD}	Pull-down Resistor		15	22	30	kΩ
V _{OL}	Output Low Voltage				0.4	V
V _{OH}	Output High Voltage		2.4			V
I _{OL}	Low Level Output Current	V _{OL(MAX)}	5			mA
I _{OH}	High Level Output Current	V _{OH(MIN)}	6			mA

(1) VDDSHV stands for corresponding power supply. For more information on the power supply name and the corresponding ball, see [Table 6-1](#), POWER column.

7.6.8 USB2PHY Electrical Characteristics

Note

USB0 Electrical Characteristics are compliant with Universal Serial Bus Revision 2.0 Specification dated April 27, 2000 including ECNs and Errata as applicable.

7.6.9 SERDES Electrical Characteristics

Note

The PCIe interfaces are compliant with the electrical parameters specified in PCI Express® Base Specification Revision 4.0, September 27, 2017.

This Device imposes an additional limit on SERDES REFCLK when used in Input mode with internal termination enabled, as described by parameter V_{REFCLK_TERM} in [Table 7-3](#), *SERDES REFCLK Electrical Characteristics*. Internal termination is enabled by default and must be disabled before applying a reference clock signal that exceeds the limits defined by V_{REFCLK_TERM} . External termination should always be enabled on the source side.

Table 7-3. SERDES REFCLK Electrical Characteristics

Only applies when internal termination is enabled. Over recommended operating conditions (unless otherwise noted)

PARAMETER		MIN	TYP	MAX	UNIT
BALL NAMES in Mode 0: SERDES0_REFCLK_P, SERDES0_REFCLK_N					
BALL NUMBERS: AA9 / AA8					
V_{REFCLK_TERM}	Single ended voltage threshold at the reference clock pin when internal termination is enabled			400	mV
R_{TERM}	Internal termination	40	50	62.5	Ω

Note

The SerDes USB interface is compliant with the USB3.1 SuperSpeed Transmitter and Receiver Normative Electrical Parameters as defined in the Universal Serial Bus 3.1 Specification, Revision 1.0 , July 26, 2013.

Note

The SGMII interfaces electrical characteristics are compliant with 1000BASE-KX per IEEE802.3 Clause 70.

Note

The SGMII 2.5G / XAUI interfaces electrical characteristics are compliant with IEEE802.3 Clause 47.

Note

The QSGMII interface electrical characteristics are compliant with QSGMII Specification revision 1.2.

Note

USXGMII supports IEEE 802.3 TX and RX electrical characteristics of Clause 72-7 and Annex 69B.

IEEE 802.3 Tables 72-7 and 72-8 are not required by USXGMII since these tables are associated with training (Clause 72-6), which is not a requirement of USXGMII.

The pre, main, and post cursors should be set by using BER sweeps.

Note

The XFI interface electrical characteristics are compliant with the INF-8077_XFP_XFI_10Gbps_1X specification revision 4.5, August 31, 2005.

7.6.10 DDR Electrical Characteristics

Note

The DDR interface is compatible with JEDEC JESD209-4B standards compliant LPDDR4 SDRAM devices.

7.7 VPP Specifications for One-Time Programmable (OTP) eFuses

This section specifies the operating conditions required for programming the OTP eFuses and is applicable only for High-Security Devices.

7.7.1 Recommended Operating Conditions for OTP eFuse Programming

over operating free-air temperature range (unless otherwise noted)

PARAMETER	DESCRIPTION	MIN	NOM	MAX	UNIT
VDD_CORE	Supply voltage range for the core domain during OTP operation; OPP NOM (BOOT)	See Section 7.3			V
VDD_MCU	Supply voltage range for the core domain during OTP operation; OPP NOM (BOOT)	See Section 7.3			V
VPP_CORE	Supply voltage range for the eFuse ROM domain during normal operation	N/A			
	Supply voltage range for the eFuse ROM domain during OTP programming ⁽¹⁾	1.71	1.8	1.89	V
VPP_MCU	Supply voltage range for the eFuse ROM domain during normal operation	N/A			
	Supply voltage range for the eFuse ROM domain during OTP programming ⁽¹⁾	1.71	1.8	1.89	V
SR _(VPP)	VPP Slew Rate			6E + 4	V/s

(1) Supply voltage range includes DC errors and peak-to-peak noise. TI power management solutions [TLV70718](#) from the TLV707x family is a example device that meets the supply voltage range needed for VPP_CORE and VPP_MCU.

7.7.2 Hardware Requirements

The following hardware requirements must be met when programming keys in the OTP eFuses:

- The VPP_CORE and VPP_MCU power supplies must be disabled when not programming OTP registers.
- The VPP_CORE and VPP_MCU power supplies must be ramped up after the proper device power-up sequence (for more details, see [Section 7.9.2](#)).

7.7.3 Programming Sequence

Programming sequence for OTP eFuses:

- Power on the board per the power-up sequencing. No voltage should be applied on the VPP_CORE and VPP_MCU terminals during power up and normal operation.
- Load the OTP write software required to program the eFuse (contact your local TI representative for the OTP software package).
- Apply the voltage on the VPP_CORE and VPP_MCU terminals according to the specification in [Section 7.7.1](#).
- Run the software that programs the OTP registers.
- After validating the content of the OTP registers, remove the voltage from the VPP_CORE and VPP_MCU terminals.

7.7.4 Impact to Your Hardware Warranty

You recognize and accept at your own risk that your use of eFuse permanently alters the TI device. You acknowledge that eFuse can fail due to incorrect operating conditions or programming sequence. Such a failure may render the TI device inoperable and TI will be unable to confirm the TI device conformed to TI device specifications prior to the attempted eFuse. CONSEQUENTLY, TI WILL HAVE NO LIABILITY FOR ANY TI DEVICES THAT HAVE BEEN eFUSED.

7.8 Thermal Resistance Characteristics

This section provides the thermal resistance characteristics used on this device.

For reliability and operability concerns, the maximum junction temperature of the device has to be at or below the T_J value identified in [Section 7.3, Recommended Operating Conditions](#).

7.8.1 Thermal Resistance Characteristics

It is recommended to perform thermal simulations at the system level with the worst case device power consumption.

NO.	PARAMETER	DESCRIPTION	ALM PACKAGE	
			°C/W ⁽¹⁾⁽³⁾	AIR FLOW (m/s) ⁽²⁾
T1	RO_{JC}	Junction-to-case	0.54	N/A
T2	RO_{JB}	Junction-to-board	2.9	N/A
T3	RO_{JA}	Junction-to-free air	12.8	0
T4		Junction-to-moving air	9.1	1
T5			8.1	2
T6			7.5	3
T7	Ψ_{JT}	Junction-to-package top	0.5	0
T8			0.3	1
T9			0.3	2
T10			0.3	3
T11	Ψ_{JB}	Junction-to-board	2.8	0
T12			2.8	1
T13			2.7	2
T14			2.7	3

(1) These values are based on a JEDEC defined 2S2P system (with the exception of the Theta JC [RO_{JC}] value, which is based on a JEDEC defined 1S0P system) and will change based on environment as well as application. For more information, see these EIA/JEDEC standards:

- JESD51-2, *Integrated Circuits Thermal Test Method Environment Conditions - Natural Convection (Still Air)*
- JESD51-3, *Low Effective Thermal Conductivity Test Board for Leaded Surface Mount Packages*
- JESD51-6, *Integrated Circuit Thermal Test Method Environmental Conditions - Forced Convection (Moving Air)*
- JESD51-7, *High Effective Thermal Conductivity Test Board for Leaded Surface Mount Packages*
- JESD51-9, *Test Boards for Area Array Surface Mount Packages*

(2) m/s = meters per second.

(3) °C/W = degrees Celsius per watt.

7.9 Timing and Switching Characteristics

Note

The timings presented in this section are valid when the DRV_STR (Drive Strength) control in the associated PADCONFIG registers are set to the default “0h – Nominal (recommended)” value.

7.9.1 Timing Parameters and Information

The timing parameter symbols used in [Section 7.9](#) are created in accordance with JEDEC Standard 100. To shorten the symbols, some pin names and other related terminologies have been abbreviated in [Table 7-4](#):

Table 7-4. Timing Parameters Subscripts

SYMBOL	PARAMETER
c	Cycle time (period)
d	Delay time
dis	Disable time
en	Enable time
h	Hold time
su	Setup time
START	Start bit
t	Transition time
v	Valid time
w	Pulse duration (width)
X	Unknown, changing, or don't care level
F	Fall time
H	High
L	Low
R	Rise time
V	Valid
IV	Invalid
AE	Active Edge
FE	First Edge
LE	Last Edge
Z	High impedance

7.9.2 Power Supply Sequencing

This section describes power supply sequencing required to ensure proper device operation. The power supply names described in this section comprise a superset of a family of compatible devices. Some members of this family will not include a subset of these power supplies and their associated device modules.

7.9.2.1 Power Supply Slew Rate Requirement

To maintain the safe operating range of the internal ESD protection devices, TI recommends limiting the maximum slew rate of supplies to be less than 100 mV/μs. For instance, as shown in Figure 7-2, TI recommends having the supply ramp slew for a 1.8-V supply of more than 18 μs.

Figure 7-2 describes the Power Supply Slew Rate Requirement in the device.

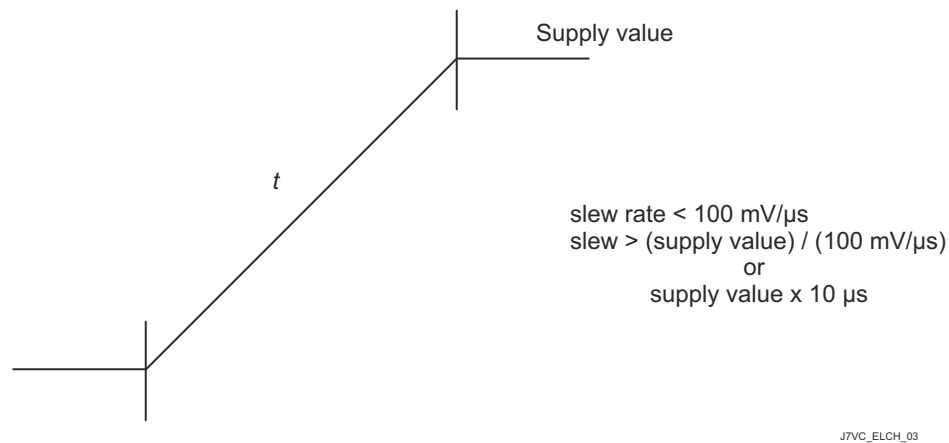
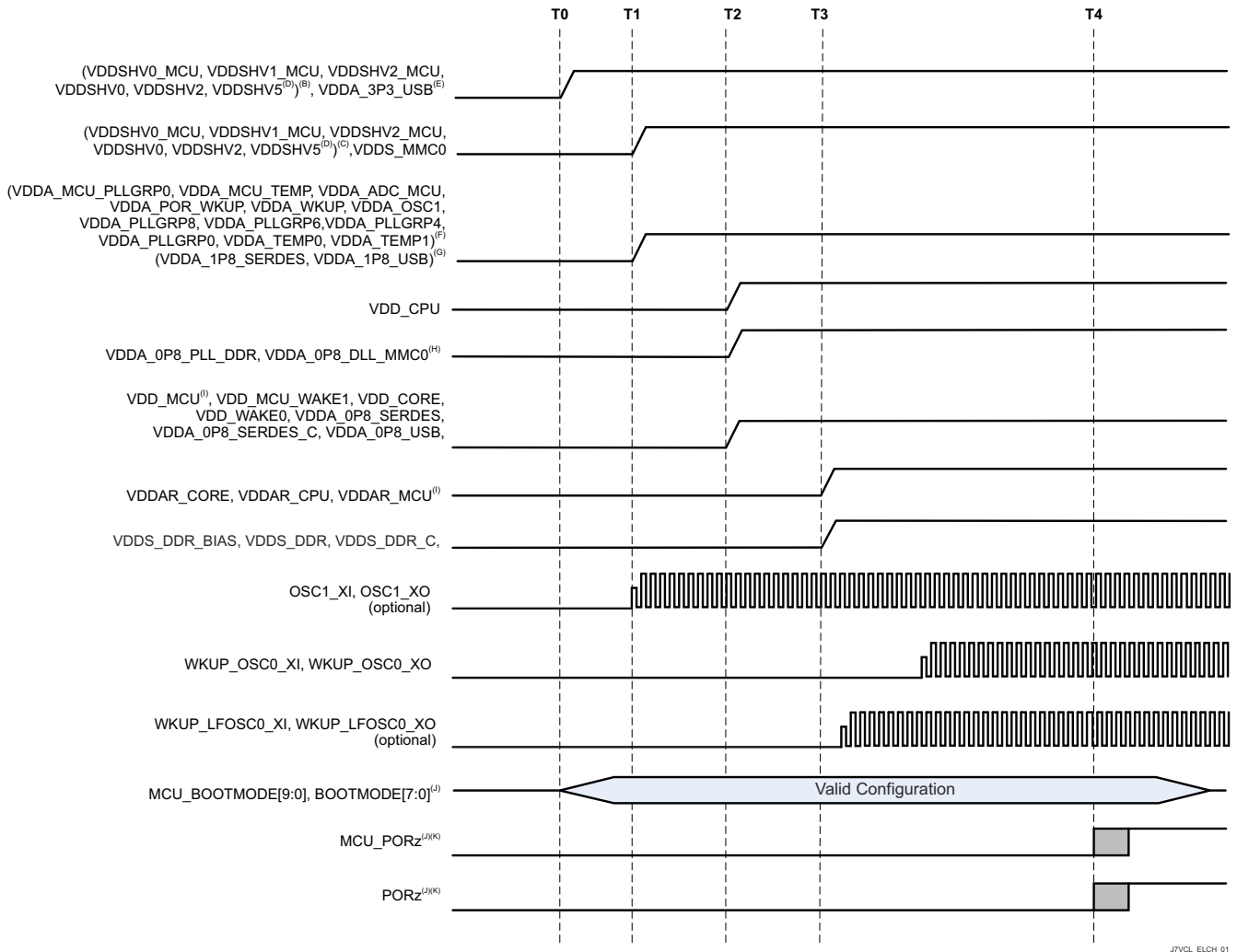

Figure 7-2. Power Supply Slew and Slew Rate

7.9.2.2 Combined MCU and Main Domains Power- Up Sequencing

Figure 7-3 describes the primary power-up sequencing when similar MCU and Main voltage domains are combined into common power rails. Combining MCU and Main voltage domains makes an SoC's MCU and Main processor sub-systems operational dependent on common power rails. The main reason an SoC's PDN design may want to group MCU and Main voltage domains is simplify the PDN by reducing total number of power rails and sources. This simplified PDN would be used in systems that do not desire independent MCU and Main processor sub-system operations.



A. Terminology:

- Primary = Essential power up sequence of all voltage domains to full active state.
- $V_{OPR\ MIN}$ = Minimum operational voltage level that ensures functionality as specified in , *Recommended Operating Conditions*.
- Ramp Up = Voltage supply transition time from off condition to $V_{OPR\ MIN}$.
- Domain_“n” = multiple instances of similar voltage domains (that is, dual voltage IO domains, VDDSHVn = VDDSHV0, VDDSHV1, VDDSHV2 ... VDDSHV6)
- Domain_“xxx” = different signal type/protocol domains using same voltage supply type and level (that is, VDDA_1P8_xx = VDDA_1P8_DSITX, VDDA_1P8_USB, VDDA_0P8_DSITX, VDDA_0P8_USB, etc.)

Time stamps:

Markers showing approximate elapsed times that are dependent upon PDN feature set, component selection and power mapping. Values shown are typical for PDNs combining MCU and Main voltage domains but could vary based upon PDN design.

Time Stamp definitions and (typical values for reference only):

- T0 – All 3.3-V voltages start supply ramp-up to $V_{OPR\ MIN}$. (0 ms)
- T1 – All 1.8-V voltages start supply ramp-up to $V_{OPR\ MIN}$. (0.5 ms)

- T2 – All core voltages start supply ramp-up to $V_{OPR\ MIN}$. (1.0 ms)
- T3 – All RAM array voltages start supply ramp-up to $V_{OPR\ MIN}$. (1.5 ms)
- T4 – OSC1 is stable and PORz/MCU_PORz are de-asserted to release processor from reset. (11 ms)
- B. Any MCU or Main dual voltage IO domains (VDDSHVn_MCU or VDDSHVn) being supplied by 3.3 V to support 3.3-V digital interfaces.
- C. Any MCU or Main dual voltage IO domains (VDDSHVn_MCU or VDDSHVn) being supplied by 1.8 V to support 1.8-V digital interfaces.
- D. VDDSHV5 supports MMC1 signaling for SD memory cards. A dual voltage (3.3/1.8 V) power rail is required for compliant, high-speed SD card operations. If SD card is not needed or standard data rates with fixed 3.3-V operation is acceptable, then domain can be grouped with digital IO 3.3-V power rail. If a SD card is capable of operating with fixed 1.8 V, then domain can be grouped with digital IO 1.8-V power rail.
- E. VDDA_3P3_USB is 3.3-V analog domain used for USB 2.0 differential interface signaling. A low noise, analog supply is recommended to provide best signal integrity for USB data eye mask compliance. If USB interface is not needed or data bit errors can be tolerated, then domain can be grouped with 3.3-V digital IO power rail either directly or through a supply filter.
- F. VDDA_1P8_<clk/pll/ana> are 1.8-V analog domains supporting clock oscillator, PLL and analog circuitry needing a low noise supply for optimal performance. It is not recommended to combine digital VDDSHVn_MCU and VDDSHVn IO domains since high frequency switching noise could negatively impact jitter performance of clock, PLL and DLL signals. Combining analog VDDA_1p8_<phy> domains should be avoided but if grouped, then in-line ferrite bead supply filtering is required.
- G. VDDA_1P8_<phy> are 1.8-V analog domains supporting multiple serial PHY interfaces. A low noise, analog supply is recommended to provide best signal integrity, interface performance and spec compliance. If any of these interfaces are not needed, data bit errors or non-compliant operation can be tolerated, then domains can be grouped with digital IO 1.8-V power rail either directly or through an in-line supply filter is allowed.
- H. VDDA_0P8_<dll/pll> are 0.8 V analog domains supporting PLL and DLL circuitry needing a low noise supply for optimal performance. It is not recommended to combine these domains with any other 0.8-V domains since high frequency switching noise could negatively impact jitter performance of PLL and DLL signals.
- I. VDD_MCU is a digital voltage domain with a wide range enabling it to be grouped and ramped-up with either 0.8-V VDD_CORE or 0.85-V RAM array (VDDAR_xxx) domains.
- J. Minimum set-up and hold times shown with respect to MCU_PORz and PORz asserting high to latch MCU_BOOTMODEn (referenced to MCU_VDDSHV0) and BOOTMODEn (reference to VDDSHV2) settings into registers during power-up sequence.
- K. Minimum elapsed time from crystal oscillator circuitry being energized (VDDA_OSC1 at T1) until stable clock frequency is reached depends upon on crystal oscillator, capacitor parameters and PCB parasitic values. A conservative 10- ms elapsed time defined by (T4 – T1) time stamps is shown. This could be reduced depending upon customer's clock circuit (that is, crystal oscillator or clock generator) and PCB designs.

Figure 7-3. Combined MCU and Main Domains, Primary Power-Up Sequence

7.9.2.3 Combined MCU and Main Domains Power- Down Sequencing

Figure 7-4 describes the device power-down sequencing.

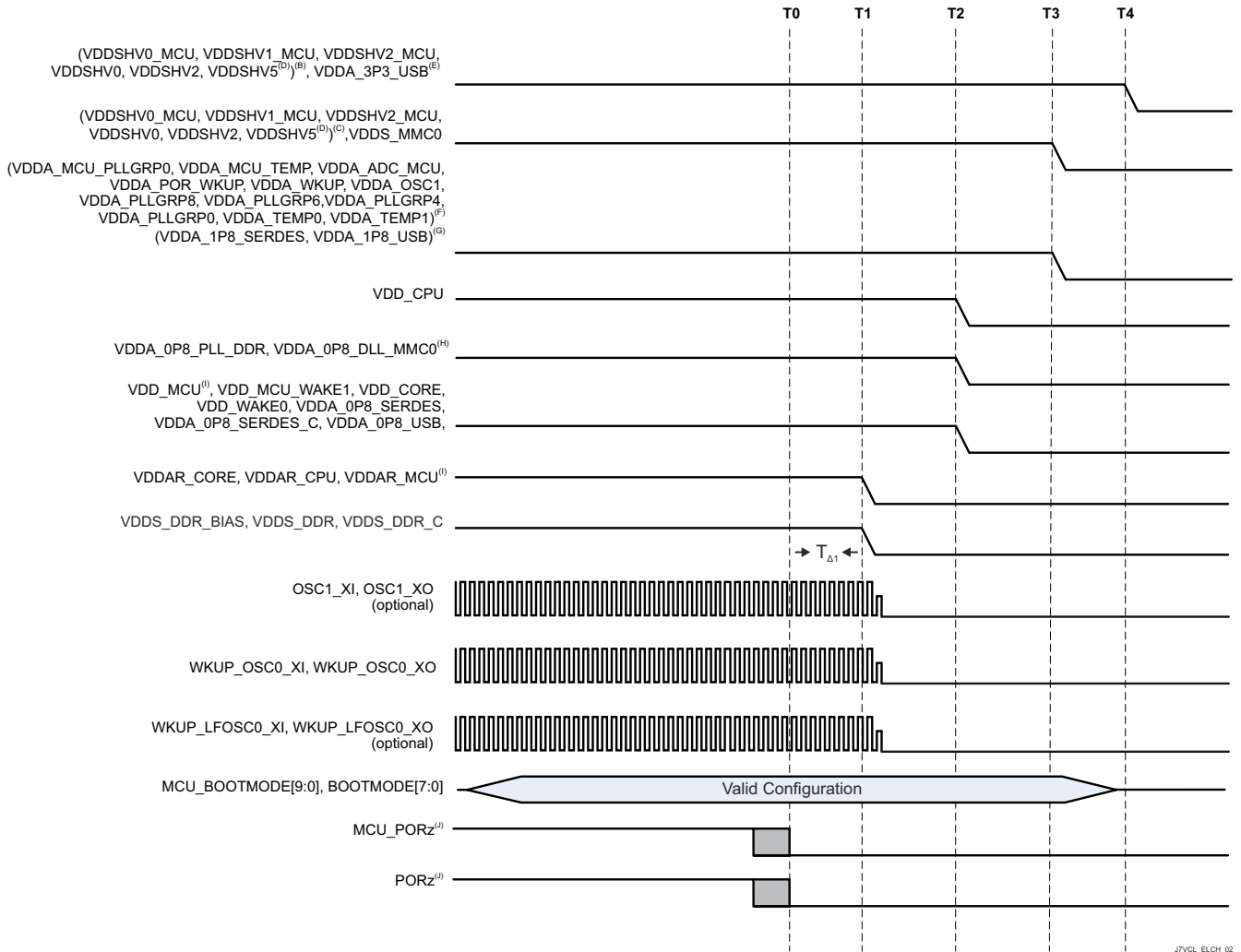

A. Terminology:

- Primary = Essential power down sequence of all voltage domains to complete off state.
- $V_{OPR\ MIN}$ = Minimum operational voltage level that ensures functionality as specified in , *Recommended Operating Conditions*.
- Ramp-down = voltage supply transition time from $V_{OPR\ MIN}$ to off condition.
- Domain_“n” = multiple instances of similar voltage domains (that is, dual voltage IO domains, VDDSHVn = VDDSHV0, VDDSHV1, VDDSHV2 ... VDDSHV6)
- Domain_“xxx” = different signal type/protocol domains using same voltage supply type and level (that is, VDDA_1P8_xx = VDDA_1P8_DSITX, VDDA_1P8_USB, VDDA_0P8_DSITX, VDDA_0P8_USB, etc.)

Time stamps:

Markers showing approximate elapsed times that are dependent upon PDN feature set, component selection and power mapping. Values shown are typical for PDNs combining MCU and Main voltage domains but could vary based upon PDN design.

Time Stamp definitions and (typical values for reference only):

- T0 – MCU_PORz and PORz assert low to put all processor resources in safe state. (0 ms)
- T1 – Main DDR, SRAM Core and SRAM CPU power domains start ramp-down. (0.5 ms)
- T2 – All core voltages start supply ramp-down. (2.5 ms)
- T3 – All 1.8V voltages start supply ramp-down. (3.0 ms)
- T4 – All 3.3-V voltages start supply ramp-down. (3.5 ms)

- B. Any MCU or Main dual voltage IO domains (VDDSHVn_MCU or VDDSHVn) being supplied by 3.3 V to support 3.3-V digital interfaces.
- C. Any MCU or Main dual voltage IO domains (VDDSHVn_MCU or VDDSHVn) being supplied by 1.8 V to support 1.8-V digital interfaces.

- D. VDDSHV5 supports MMC1 signaling for SD memory cards. A dual voltage (3.3/1.8 V) power rail is required for compliant, high-speed SD card operations. If SD card is not needed or standard data rates with fixed 3.3-V operation is acceptable, then domain can be grouped with digital IO 3.3-V power rail. If a SD card is capable of operating with fixed 1.8 V, then domain can be grouped with digital IO 1.8-V power rail.
- E. VDDA_3P3_USB is 3.3-V analog domain used for USB 2.0 differential interface signaling. A low noise, analog supply is recommended to provide best signal integrity for USB data eye mask compliance. If USB interface is not needed or data bit errors can be tolerated, then domain can be grouped with 3.3-V digital IO power rail either directly or through a supply filter.
- F. VDDA_1P8_<clk/pll/ana> are 1.8-V analog domains supporting clock oscillator, PLL and analog circuitry needing a low noise supply for optimal performance. It is not recommended to combine digital VDDSHVn_MCU and VDDSHVn IO domains since high frequency switching noise could negatively impact jitter performance of clock, PLL and DLL signals. Combining analog VDDA_1p8_<phy> domains should be avoided but if grouped, then in-line ferrite bead supply filtering is required.
- G. VDDA_1P8_<phy> are 1.8-V analog domains supporting multiple serial PHY interfaces. A low noise, analog supply is recommended to provide best signal integrity, interface performance and spec compliance. If any of these interfaces are not needed, data bit errors or non-compliant operation can be tolerated, then domains can be grouped with digital IO 1.8-V power rail either directly or through an in-line supply filter is allowed.
- H. VDDA_0P8_<dll/pll> are 0.8-V analog domains supporting PLL and DLL circuitry needing a low noise supply for optimal performance. It is not recommended to combine these domains with any other 0.8-V domains since high frequency switching noise could negatively impact jitter performance of PLL and DLL signals.
- I. VDD_MCU is a digital voltage domain with a wide range enabling it to be grouped and ramped-up with either 0.8-V VDD_CORE or 0.85-V RAM array (VDDAR_xxx) domains.
- J. MCU_PORz and PORz must be asserted low for $T_{\Delta 1} = 200 \mu\text{s}$ min to ensure SoC resources enter into safe state before any voltage begins to ramp down.

Figure 7-4. Combined MCU and Main Domains, Primary Power-Down Sequence

7.9.2.4 Independent MCU and Main Domains Power- Up Sequencing

Independent MCU and Main voltage domains enable an SoC's MCU and Main processor sub-systems to operate independently. There are 2 reasons an SoC's PDN design may need to support independent MCU and Main processor functionality. First is to provide flexibility to enable SoC low power modes that can significantly reduce SoC power dissipation when processor operations are not needed. Second is to enable robustness to gain freedom from interference (FFI) of a single fault impacting both MCU and Main processor sub-systems which is especially beneficial if using the SoC's MCU as the system safety monitoring processor. The number of additional PDN power rails needed is dependent upon number of different MCU IO signaling voltage levels. If only 1.8V IO signaling is used, the only 2 additional power rails could be required. If both 1.8 and 3.3V IO signaling is desired, then 4 additional power rails could be needed.

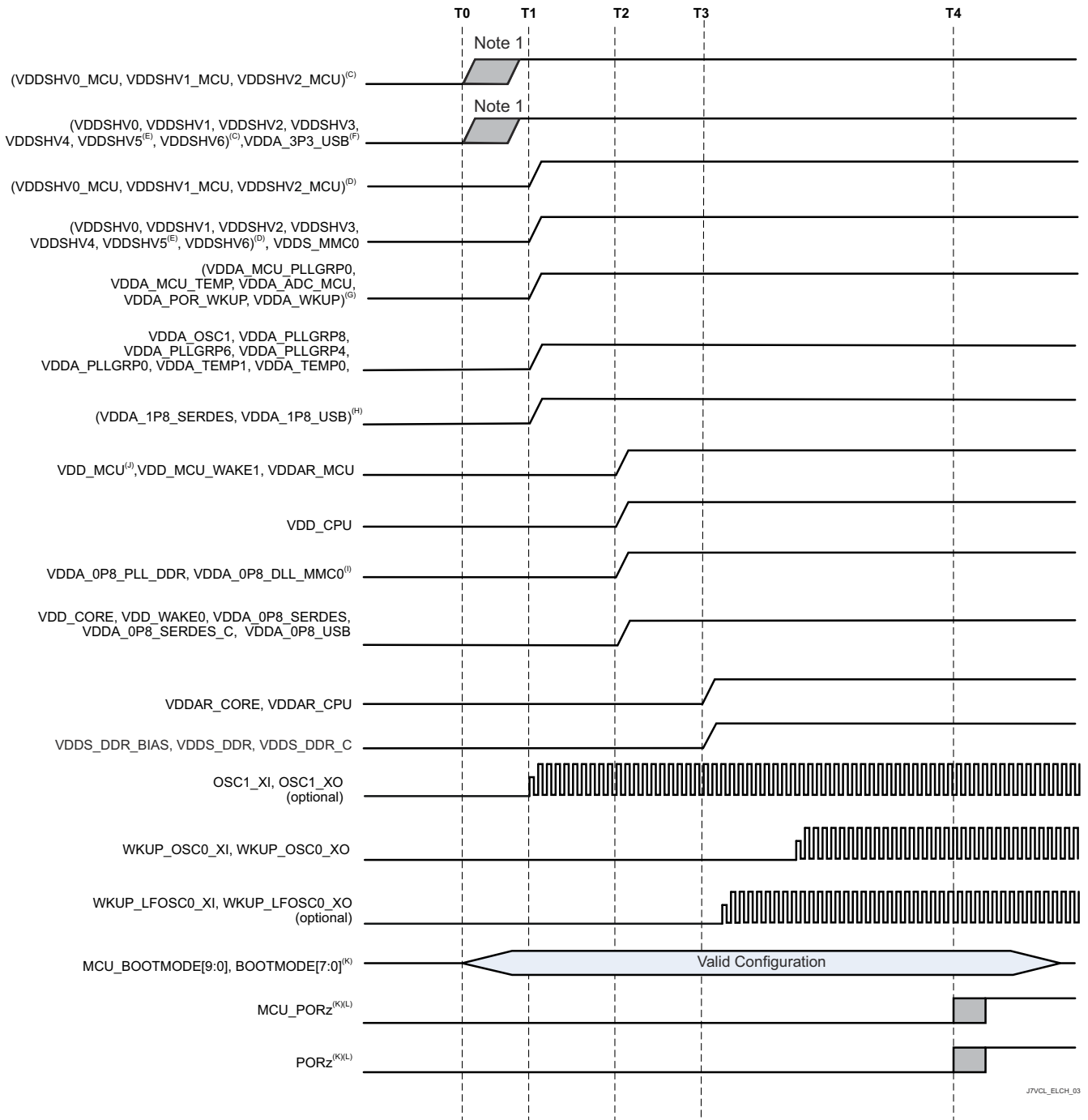
A. Terminology:

- Primary = Essential power up sequence of all voltage domains to full active state.
- $V_{OPR\ MIN}$ = Minimum operational voltage level that ensures functionality as specified in , *Recommended Operating Conditions*.
- Ramp Up = Voltage supply transition time from off condition to $V_{OPR\ MIN}$.
- Domain “n” = multiple instances of similar voltage domains (that is, dual voltage IO domains, $VDDSHVn = VDDSHV0, VDDSHV1, VDDSHV2 \dots VDDSHV6$)
- Domain “xxx” = different signal type/protocol domains using same voltage supply type and level (that is, $VDDA_1P8_xx = VDDA_1P8_DSITX, VDDA_1P8_USB, VDDA_0P8_DSITX, VDDA_0P8_USB, etc.$)

Time stamp markers show approximate elapsed times that are dependent upon PDN feature set, component selection and power mapping. Values shown are typical for PDNs supporting independent MCU and Main voltage domains but could vary based upon PDN design.

- Time Stamp definitions and (typical values for reference only):
- T0 – All 3.3V voltages start supply ramp-up to $V_{OPR\ MIN}$. (0 ms)
 - T1 – All 1.8V voltages start supply ramp-up to $V_{OPR\ MIN}$. (2 ms)
 - T2 – All core voltages start supply ramp-up to $V_{OPR\ MIN}$. (3 ms)
 - T3 – All RAM array voltages start supply ramp-up to $V_{OPR\ MIN}$. (4 ms)
 - T4 – OSC1 is stable and PORz/MCU_PORz are de-asserted to release processor from reset. (13 ms)
- B. VDDSHVx 3.3V IO domains may have additional ramp-up delay due to following:
1. Minimizing PMIC power dissipation during low power mode that includes disabling PMIC's VIO_IN supply for GPIO output buffers.
 2. PDN component turn-on and ramp-up delays needed to isolate MCU and Main IO domains
- C. Any MCU or Main dual voltage IO domains (VDDSHVn_MCU or VDDSHVn) being supplied by 3.3 V to support 3.3-V digital interfaces.
- D. Any MCU or Main dual voltage IO domains (VDDSHVn_MCU or VDDSHVn) being supplied by 1.8 V to support 1.8-V digital interfaces.
- E. VDDSHV5 supports MMC1 signaling for SD memory cards. A dual voltage (3.3/1.8 V) power rail is required for compliant, high-speed SD card operations. If SD card is not needed or standard data rates with fixed 3.3 V operation is acceptable, then domain can be grouped with digital IO 3.3-V power rail. If a SD card is capable of operating with fixed 1.8 V, then domain can be grouped with digital IO 1.8-V power rail.
- F. VDDA_3P3_USB is 3.3-V analog domain used for USB 2.0 differential interface signaling. A low noise, analog supply is recommended to provide best signal integrity for USB data eye mask compliance. If USB interface is not needed or data bit errors can be tolerated, then domain can be grouped with 3.3-V digital IO power rail either directly or through a supply filter.
- G. VDDA_1P8_<clk/pll/ana> are 1.8-V analog domains supporting clock oscillator, PLL and analog circuitry needing a low noise supply for optimal performance. It is not recommended to combine digital VDDSHVn_MCU and VDDSHVn IO domains since high frequency switching noise could negatively impact jitter performance of clock, PLL and DLL signals. Combining analog VDDA_1p8_<phy> domains should be avoided but if grouped, then in-line ferrite bead supply filtering is required.
- H. VDDA_1P8_<phy> are 1.8-V analog domains supporting multiple serial PHY interfaces. A low noise, analog supply is recommended to provide best signal integrity, interface performance and spec compliance. If any of these interfaces are not needed, data bit errors or non-compliant operation can be tolerated, then domains can be grouped with digital IO 1.8-V power rail either directly or through an in-line supply filter is allowed.
- I. VDDA_0P8_<dll/pll> are 0.8-V analog domains supporting PLL and DLL circuitry needing a low noise supply for optimal performance. It is not recommended to combine these domains with any other 0.8-V domains since high frequency switching noise could negatively impact jitter performance of PLL and DLL signals.
- J. VDD_MCU is a digital voltage domain with a wide range enabling it to be grouped and ramped-up with either 0.8-V VDD_CORE or 0.85-V RAM array (VDDAR_xxx) domains.
- K. Minimum set-up and hold times shown with respect to MCU_PORz and PORz asserting high to latch MCU_BOOTMODEn (referenced to MCU_VDDSHV0) and BOOTMODEn (reference to VDDSHV2) settings into registers during power up sequence.
- L. Minimum elapsed time from crystal oscillator circuitry being energized (VDDA_OSC1 at T1) until stable clock frequency is reached depends upon on crystal oscillator, capacitor parameters and PCB parasitic values. A conservative 10-ms elapsed time defined by (T4 – T1) time stamps is shown. This could be reduced depending upon customer's clock circuit (that is, crystal oscillator or clock generator) and PCB designs.

Figure 7-5. Independent MCU and Main Domains, Primary Power-Up Sequence

7.9.2.5 Independent MCU and Main Domains Power- Down Sequencing

Figure 7-6 describes the device power-down sequencing.

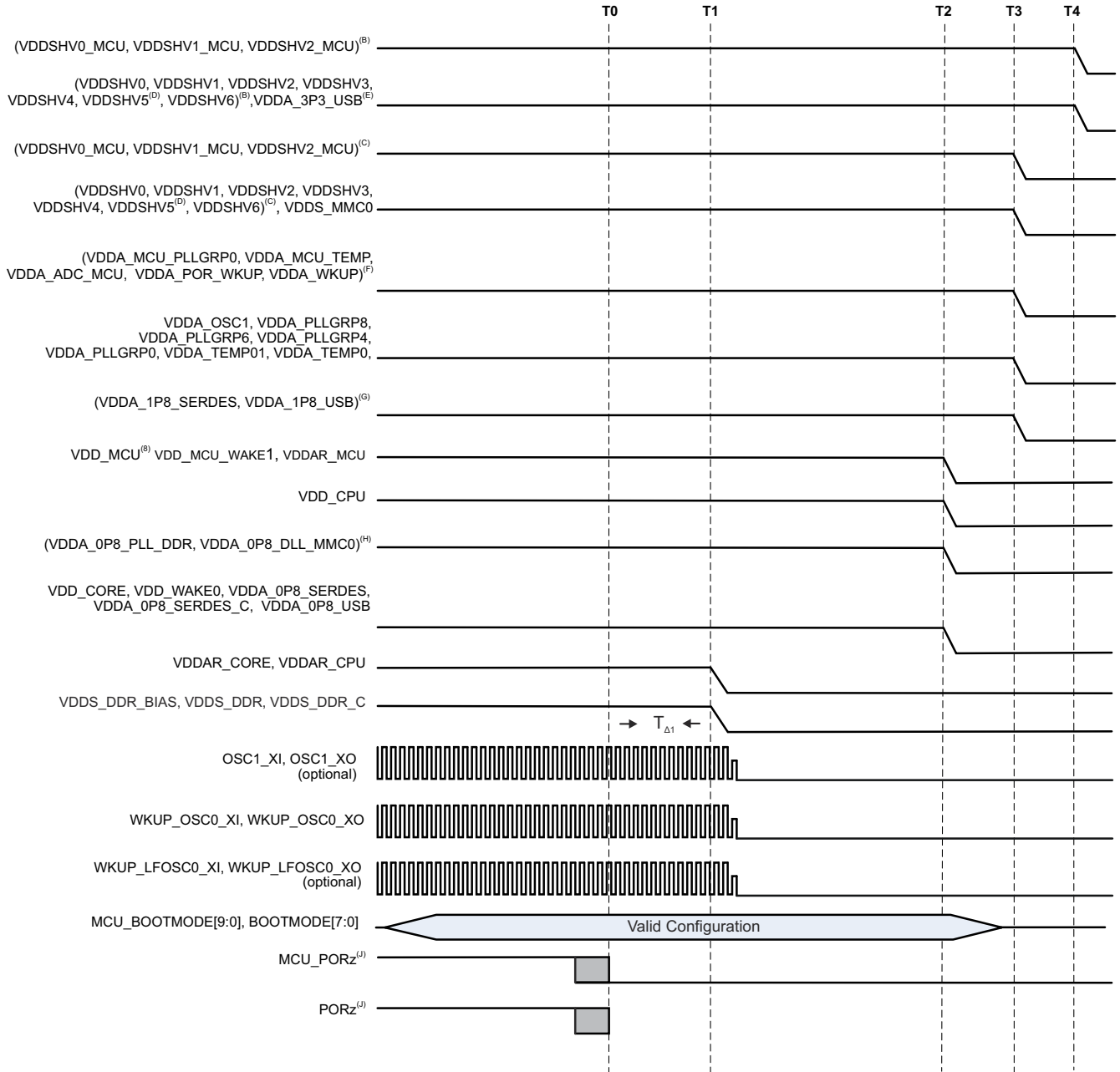

J7VCL_ELCH_04

A. Terminology:

- Primary = Essential power down sequence of all voltage domains to complete off state.
- $V_{OPR\ MIN}$ = Minimum operational voltage level that ensures functionality as specified in , *Recommended Operating Conditions*.
- Ramp-down = voltage supply transition time from $V_{OPR\ MIN}$ to off condition.
- Domain “n” = multiple instances of similar voltage domains (that is, dual voltage IO domains, VDDSHVn = VDDSHV0, VDDSHV1, VDDSHV2 ... VDDSHV6)
- Domain “xxx” = different signal type/protocol domains using same voltage supply type and level (that is, VDDA_1P8_xx = VDDA_1P8_DSITX, VDDA_1P8_USB, VDDA_0P8_DSITX, VDDA_0P8_USB, etc.)

Time stamps:

Markers showing approximate elapsed times that are dependent upon PDN feature set, component selection and power mapping. Values shown are typical for PDNs combining MCU and Main voltage domains but could vary based upon PDN design.

Time Stamp definitions and (typical values for reference only):

T0 – MCU_PORz and PORz assert low to put all processor resources in safe state. (0 ms)

T1 – Main DDR, SRAM Core and SRAM CPU power domains start ramp-down. (0.5 ms)

T2 – All core voltages start supply ramp-down. (2.5 ms)

T3 – All 1.8V voltages start supply ramp-down. (3.0 ms)

T4 – All 3.3-V voltages start supply ramp-down. (3.5 ms)

- B. Any MCU or Main dual voltage IO domains (VDDSHVn_MCU or VDDSHVn) being supplied by 3.3 V to support 3.3-V digital interfaces.
- C. Any MCU or Main dual voltage IO domains (VDDSHVn_MCU or VDDSHVn) being supplied by 1.8 V to support 1.8-V digital interfaces.
- D. VDDSHV5 supports MMC1 signaling for SD memory cards. A dual voltage (3.3/1.8 V) power rail is required for compliant, high-speed SD card operations. If SD card is not needed or standard data rates with fixed 3.3-V operation is acceptable, then domain can be grouped with digital IO 3.3-V power rail. If a SD card is capable of operating with fixed 1.8 V, then domain can be grouped with digital IO 1.8-V power rail.
- E. VDDA_3P3_USB is 3.3-V analog domain used for USB 2.0 differential interface signaling. A low noise, analog supply is recommended to provide best signal integrity for USB data eye mask compliance. If USB interface is not needed or data bit errors can be tolerated, then domain can be grouped with 3.3-V digital IO power rail either directly or through a supply filter.
- F. VDDA_1P8_<clk/pll/ana> are 1.8-V analog domains supporting clock oscillator, PLL and analog circuitry needing a low noise supply for optimal performance. It is not recommended to combine digital VDDSHVn_MCU and VDDSHVn IO domains since high frequency switching noise could negatively impact jitter performance of clock, PLL and DLL signals. Combining analog VDDA_1p8_<phy> domains should be avoided but if grouped, then in-line ferrite bead supply filtering is required.
- G. VDDA_1P8_<phy> are 1.8-V analog domains supporting multiple serial PHY interfaces. A low noise, analog supply is recommended to provide best signal integrity, interface performance and spec compliance. If any of these interfaces are not needed, data bit errors or non-compliant operation can be tolerated, then domains can be grouped with digital IO 1.8-V power rail either directly or through an in-line supply filter is allowed.
- H. VDDA_0P8_<dll/pll> are 0.8-V analog domains supporting PLL and DLL circuitry needing a low noise supply for optimal performance. It is not recommended to combine these domains with any other 0.8-V domains since high frequency switching noise could negatively impact jitter performance of PLL and DLL signals.
- I. VDD_MCU is a digital voltage domain with a wide range enabling it to be grouped and ramped-up with either 0.8-V VDD_CORE or 0.85-V RAM array (VDDAR_xxx) domains.
- J. MCU_PORz and PORz must be asserted low for $T_{\Delta 1} = 200 \mu\text{s}$ min to ensure SoC resources enter into safe state before any voltage begins to ramp down.

Figure 7-6. Independent MCU and Main Domains, Primary Power- Down Sequencing

7.9.2.6 Independent MCU and Main Domains, Entry and Exit of MCU Only Sequencing

Entry into MCU Only state is accomplished by executing a power down sequence except for the 4 MCU domains that remain energized. Exit from MCU Only state is accomplished by executing a power up sequence with the 4 MCU domains remaining energized throughout the sequence. The example diagram shown is for an Isolated MCU & Main PDN type with eMMC support.

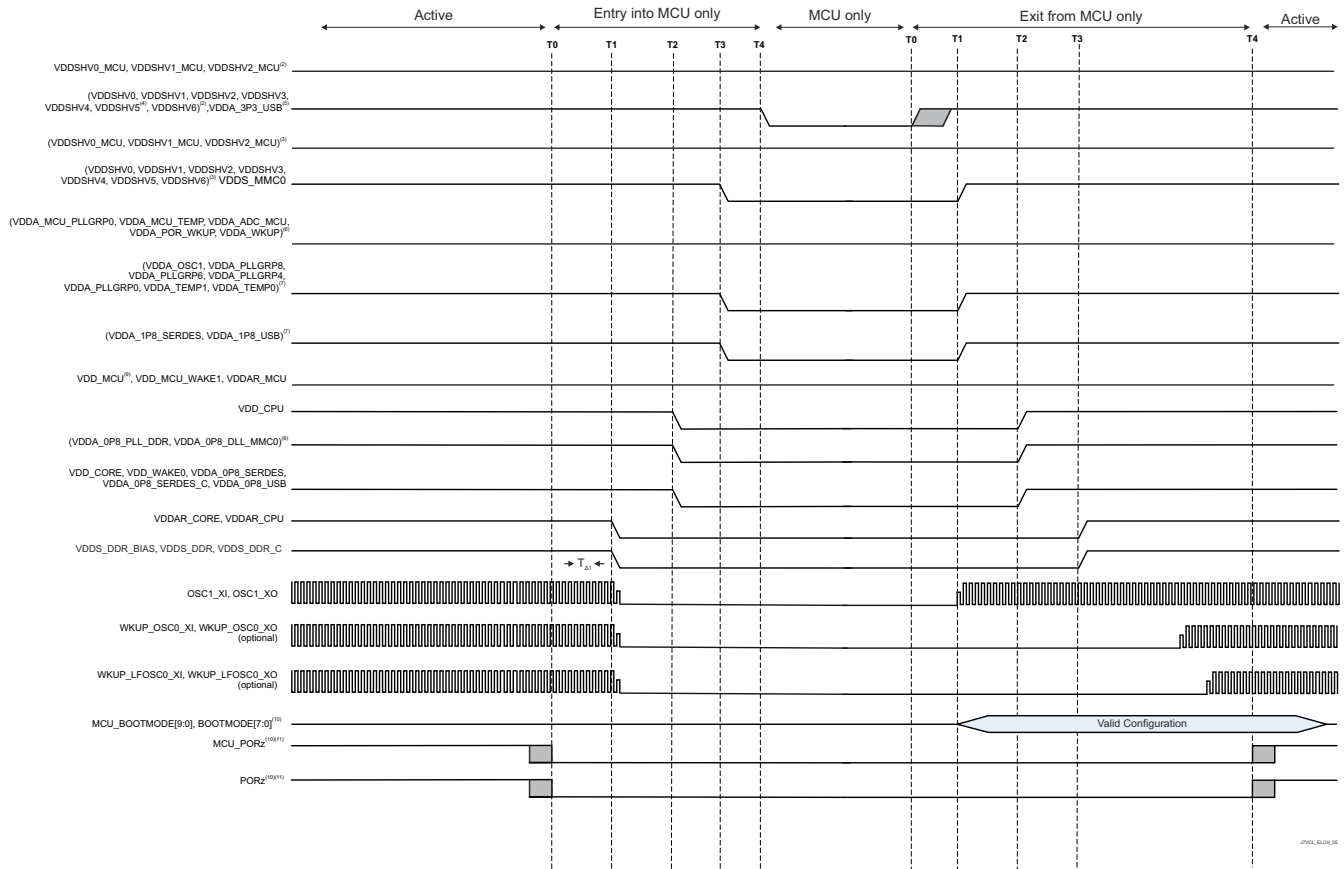

Figure 7-7. Independent MCU and Main Domains, Entry and Exit of MCU Only Sequencing

7.9.2.7 Independent MCU and Main Domains, Entry and Exit of DDR Retention State

Entry into DDR Retention state is accomplished by executing a power down sequence except for the 4 DDR domains that remain energized. Exit from DDR Retention state is accomplished by executing a power up sequence with the 3 DDR domains remaining energized throughout the sequence.

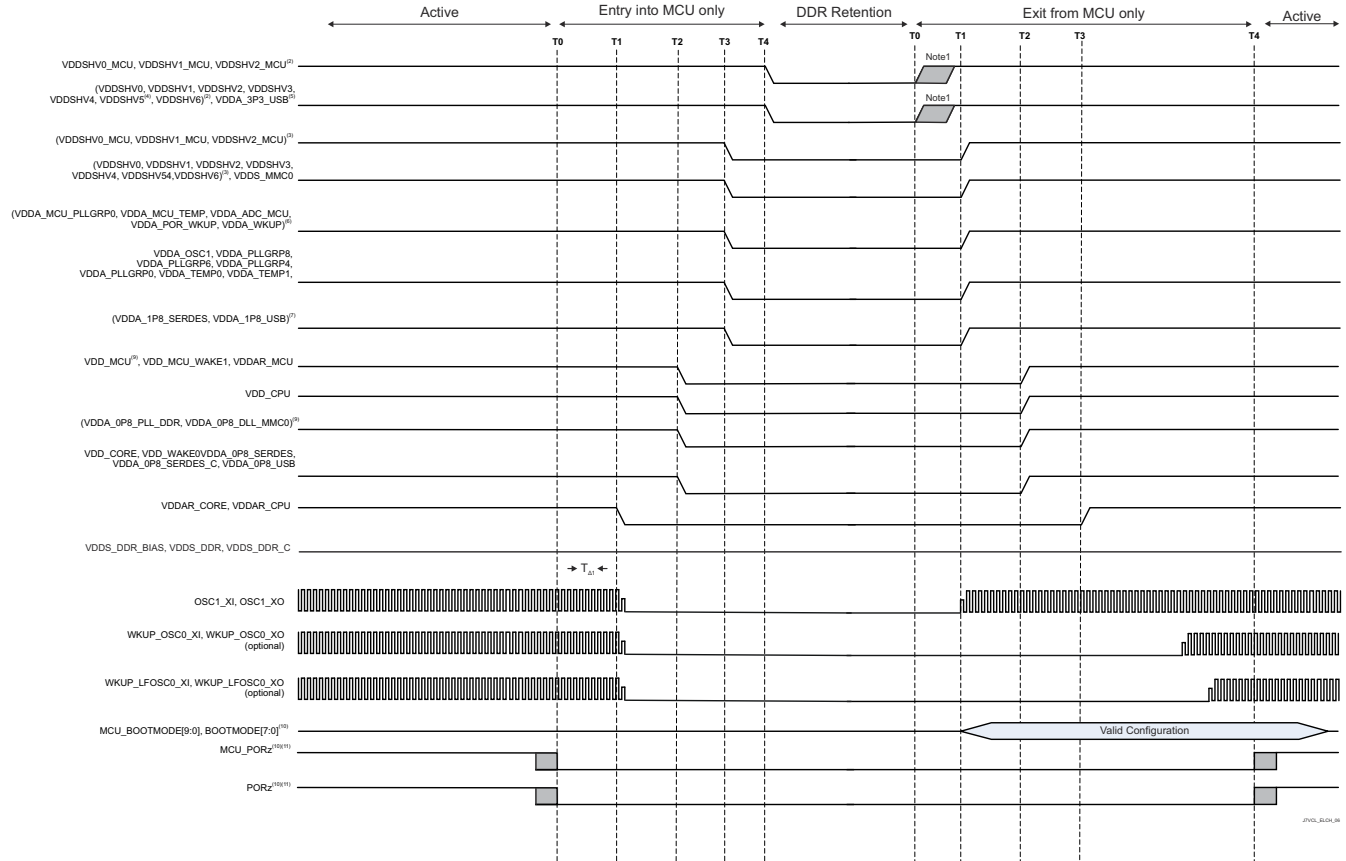

Figure 7-8. Independent MCU and Main Domains, Entry and Exit of DDR Retention State

7.9.2.8 Independent MCU and Main Domains, Entry and Exit of GPIO Retention Sequencing

Entry into GPIO Retention state is accomplished by executing a power down sequence except for the 2 or 4 wake domains that remain energized. Exit from GPIO Retention state is accomplished by executing a power up sequence with the 2 or 4 wake DDR domains remaining energized throughout the sequence.

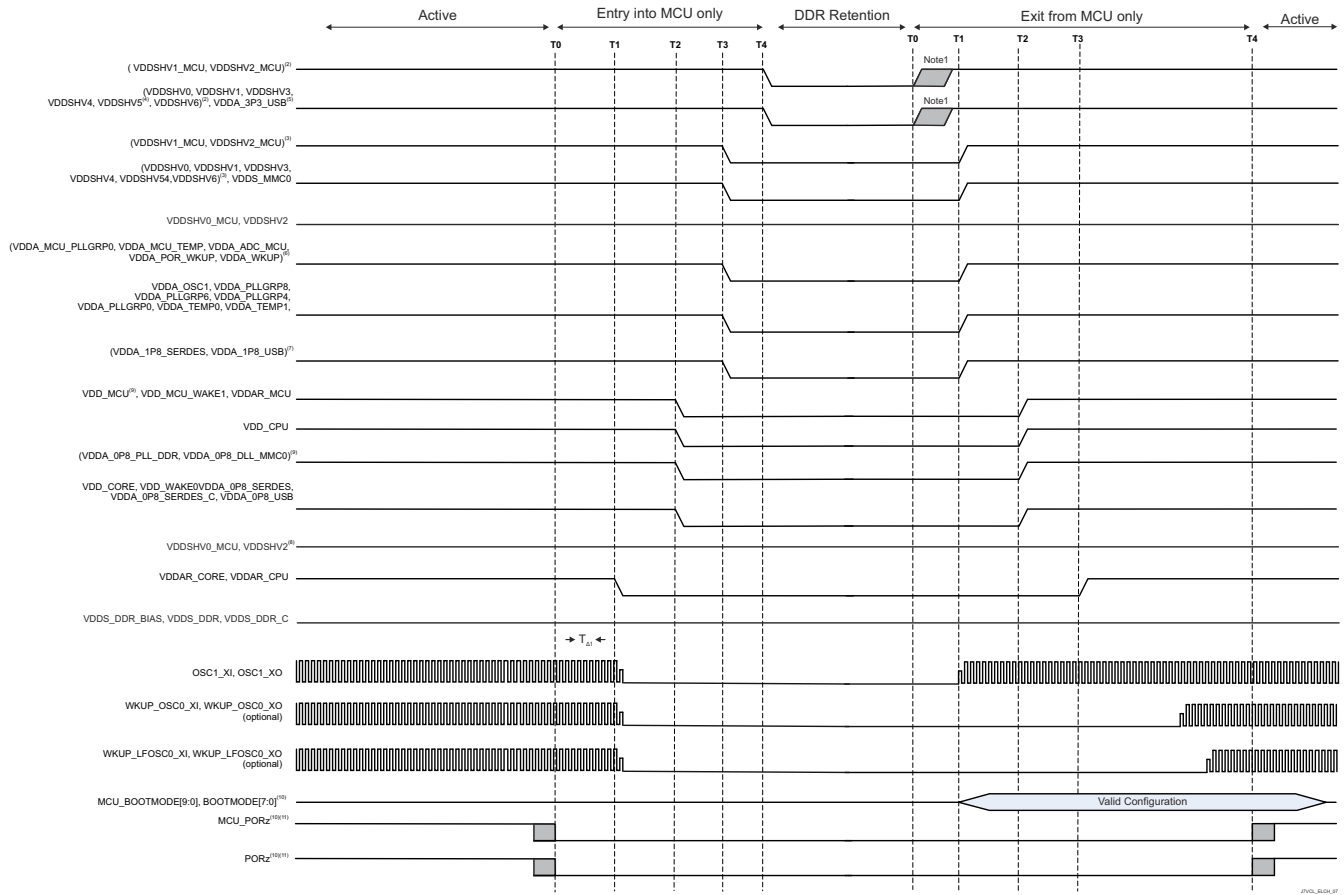

Figure 7-9. Independent MCU and Main Domains, Entry and Exit of GPIO Retention Sequencing

7.9.3 System Timing

For more details about features and additional description information on the subsystem multiplexing signals, see the corresponding sections within [Section 6.3, Signal Descriptions](#) and [Section 8, Detailed Description](#).

Table 7-5. System Timing Conditions

PARAMETER		MIN	MAX	UNIT
INPUT CONDITIONS				
SR _I	Input slew rate	0.5	2	V/ns
OUTPUT CONDITIONS				
C _L	Output load capacitance	3	30	pF

7.9.3.1 Reset Timing

Tables and figures provided in this section define timing requirements and switching characteristics for reset related signals.

Table 7-6. MCU_PORz Timing Requirements

see [Figure 7-10](#)

NO.		MIN	TYP	MAX	UNIT
RST1	Hold time, MCU_PORz active (low) at Power-up after all MCU DOMAIN supplies valid (using external crystal)	N + 1200 ⁽²⁾	9500000		ns
RST2	$t_{h(MCUD_SUPPLIES_VALID - MCU_PORz)}$ Hold time, MCU_PORz active (low) at Power-up after all MCU DOMAIN supplies ⁽¹⁾ valid and external clock stable (using external LVC MOS oscillator)	1200			ns
RST3	$t_{w(MCU_PORzL)}$ Pulse Width minimum, MCU_PORz low after Power-up (without removal of Power or system reference clock MCU_OSC0_XI/XO)	1200			ns

(1) For definition of the MCU DOMAIN supplies, see the *Combined MCU and Main Domains Power-Up sequence* TBD.

(2) N = oscillator start-up time

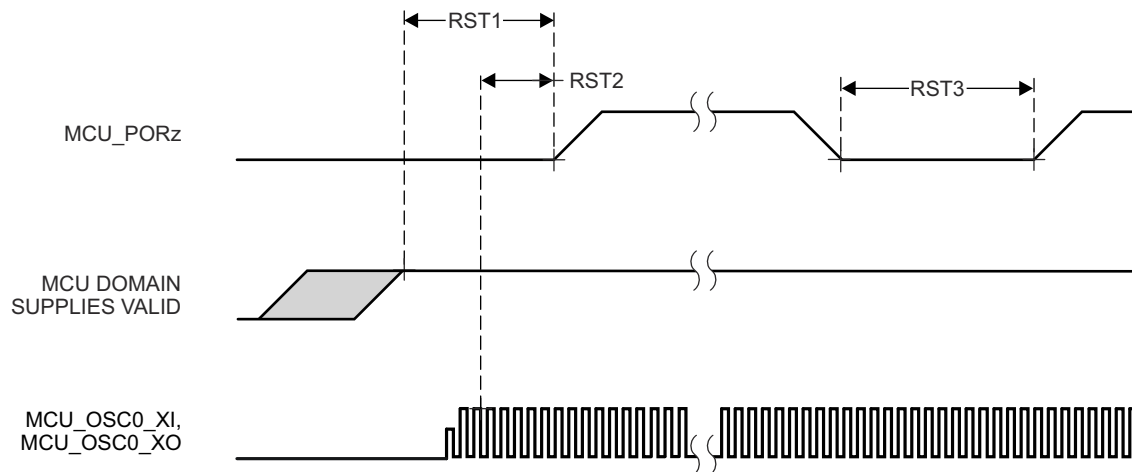

Figure 7-10. MCU_PORz Timing Requirements

Table 7-7. PORz Timing Requirements

see [Figure 7-11](#)

NO.			MIN	MAX	UNIT
RST4	$t_{h(\text{MAIND_SUPPLIES_VALID} - \text{PORz})}$	Hold time, PORz active (low) at Power-up after all MAIN DOMAIN supplies ¹ valid	1200		ns
RST5	$t_{w(\text{PORzL})}$	Pulse Width minimum, PORz low after Power-up	1200		ns

- For definition of the MAIN DOMAIN supplies, see the *Combined MCU and Main Domains Power-Up sequence* TBD.

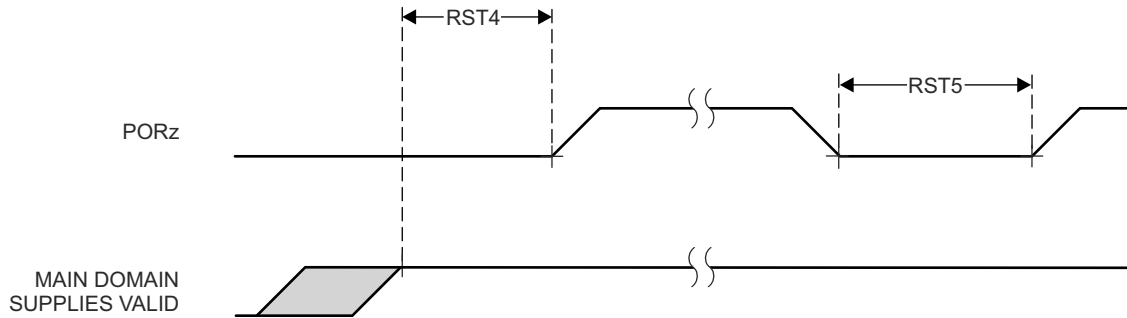

Figure 7-11. PORz Timing Requirements

Table 7-8. MCU_PORz initiates; MCU_RESETSTATz, and RESETSTATz Switching Characteristics

see [Figure 7-12](#)

NO.	PARAMETER	MODE	MIN	MAX	UNIT
RST10	$t_{d(\text{MCU_PORzL-MCU_RESETSTATzL})}$		0		ns
RST11	$t_{d(\text{MCU_PORzH-MCU_RESETSTATzH})}$	POST bypass	$12000 \cdot S^{(1)}$		ns
RST12	$t_{d(\text{MCU_PORzL-RESETSTATzL})}$		0		ns
RST13	$t_{d(\text{MCU_PORzH-RESETSTATzH})}$		$14500 \cdot S^{(1)}$		ns
RST16	$t_{w(\text{MCU_RESETSTATzL})}$		$3900 \cdot S^{(1)}$		ns
RST17	$t_{w(\text{RESETSTATzL})}$		$2650 \cdot S^{(1)}$		ns

(1) S = MCU_OSC0_XI/XO clock period.

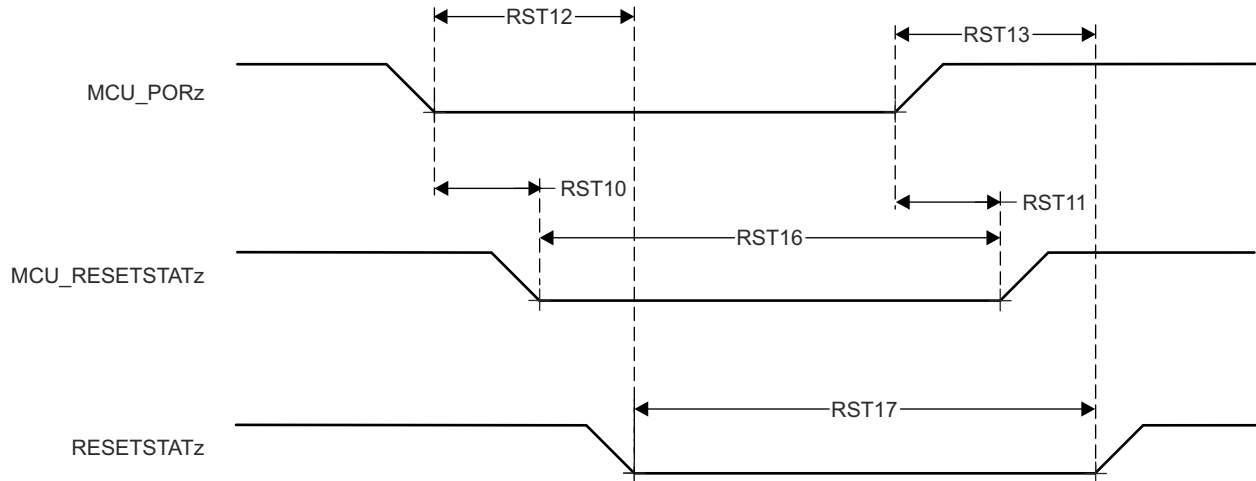

Figure 7-12. MCU_PORz initiates; MCU_RESETSTATz, and RESETSTATz Switching Characteristics

Table 7-9. PORz Initiates; PORz_OUT and RESETSTATz Switching Characteristics

see [Figure 7-13](#)

NO.	PARAMETER		MODE	MIN	MAX	UNIT
RST20	$t_{d(PORzL-RESETSTATzL)}$	Delay time, PORz active (low) to RESETSTATz active (low)		$T^{(1)}$		
			CTRLMMR_WKUP_POR_RST_CTRL[0].POR_RST_ISO_DONE_Z = 0	0		ns
RST21	$t_{d(PORzH-RESETSTATzH)}$	Delay time, PORz active (high) to RESETSTATz active (high)		14500*S ⁽²⁾		ns

(1) T = Reset Isolation Time (Software Dependent).

(2) S = MCU_OSC0_XI/XO clock period.

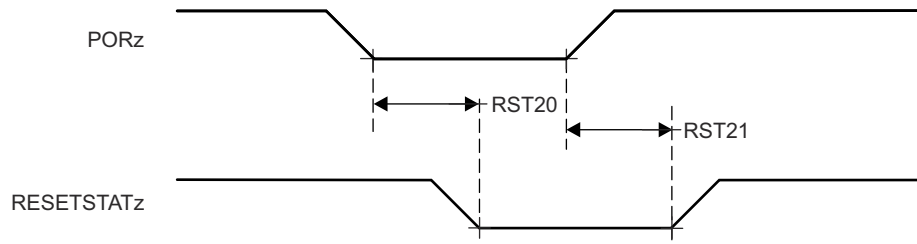

Figure 7-13. PORz initiates; RESETSTATz Switching Characteristics

Table 7-10. MCU_RESETz Timing Requirements

see [Figure 7-14](#)

NO.		MIN	MAX	UNIT
RST22	$t_{w(MCU_RESETzL)}$ ⁽¹⁾	1200		ns

(1) Timing for MCU_RESETz is valid only after all supplies are valid and MCU_PORz has been asserted for the specified time.

Table 7-11. MCU_RESETz initiates; MCU_RESETSTATz, and RESETSTATz Switching Characteristics

see [Figure 7-14](#)

NO.	PARAMETER	MIN	MAX	UNIT
RST23	$t_{d(MCU_RESETzL-MCU_RESETSTATzL)}$	800		ns
RST24	$t_{d(MCU_RESETzH-MCU_RESETSTATzH)}$	3900*S ⁽¹⁾		ns
RST25	$t_{d(MCU_RESETzL-RESETSTATzL)}$	800		ns
RST26	$t_{d(MCU_RESETzH-RESETSTATzH)}$	3900*S ⁽¹⁾		ns

(1) S = MCU_OSC0_XI/XO clock period.

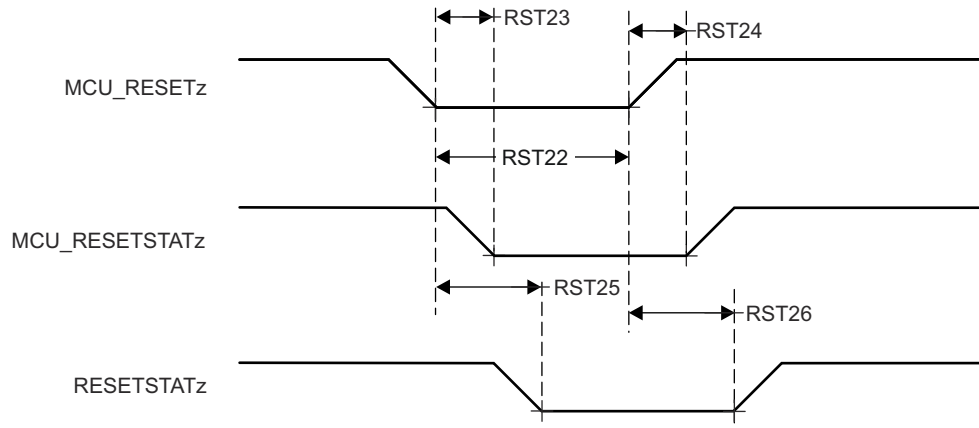

Figure 7-14. MCU_RESETz initiates; MCU_RESETSTATz, and RESETSTATz Timing Requirements and Switching Characteristics

Table 7-12. RESET_REQz Timing Requirements

see [Figure 7-15](#)

NO.		MIN	MAX	UNIT	
RST27	$t_{w(RESSET_REQzL)}$ ⁽¹⁾	Pulse Width minimum, RESET_REQz active (low)		1200	ns

(1) Timing for RESET_REQz is valid only after all supplies are valid and MCU_PORz has been asserted for the specified time.

Table 7-13. RESET_REQz initiates; RESETSTATz Switching Characteristics

see [Figure 7-15](#)

NO.	PARAMETER	MODE	MIN	MAX	UNIT
RST28	$t_{d(RESSET_REQzL-RESSETSTATzL)}$	software control of SOC_WARMRST_ISO_DONE_Z	T ⁽¹⁾		
		CTRLMMR_WKUP_MAIN_WARM_RST_CTRL[0].SOC_WARMRST_ISO_DONE_Z = 0	740		ns
RST29	$t_{d(RESSET_REQzH-RESSETSTATzH)}$	Delay time, RESET_REQz inactive (high) to RESETSTATz inactive (high)	2650*S ⁽²⁾		ns

(1) T = Reset Isolation Time (Software Dependent).

(2) S = MCU_OSC0_XI/XO clock period.

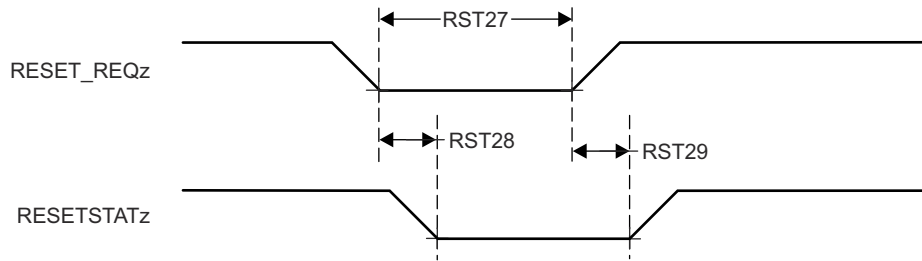

Figure 7-15. RESET_REQz initiates; RESETSTATz Timing Requirements and Switching Characteristics

Table 7-14. EMUx Timing Requirements

see [Figure 7-16](#)

NO.			MIN	MAX	UNIT
RST30	$t_{su}(EMUx-MCU_PORz)$	Setup time, EMU[1:0] before MCU_PORz inactive (high)	$3 \cdot S^{(1)}$		ns
RST31	$t_h(MCU_PORz - EMUx)$	Hold time, EMU[1:0] after MCU_PORz inactive (high)	10		ns

(1) S = MCU_OSC0_XI/XO clock period.

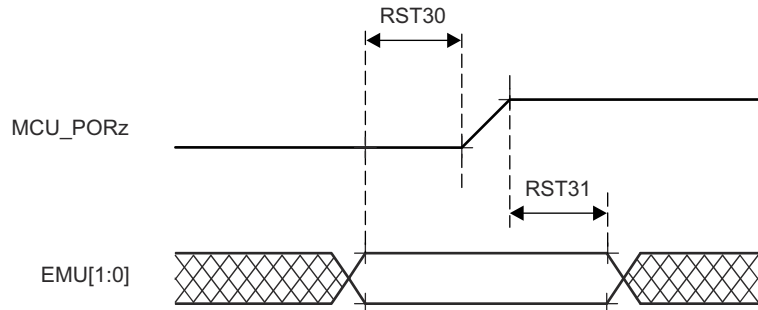

Figure 7-16. EMUx Timing Requirements

Table 7-15. MCU_BOOTMODE Timing Requirements

see [Figure 7-17](#)

NO.			MIN	MAX	UNIT
RST32	$t_{su}(MCU_BOOTMODE-MCU_PORz)$	Setup time, MCU_BOOTMODE[09:00] before MCU_PORz high	$3 \cdot S^{(1)}$		ns
RST33	$t_h(MCU_PORz - MCU_BOOTMODE)$	Hold time, MCU_BOOTMODE[09:00] after MCU_PORz high	0		ns

(1) S = MCU_OSC0_XI/XO clock period.

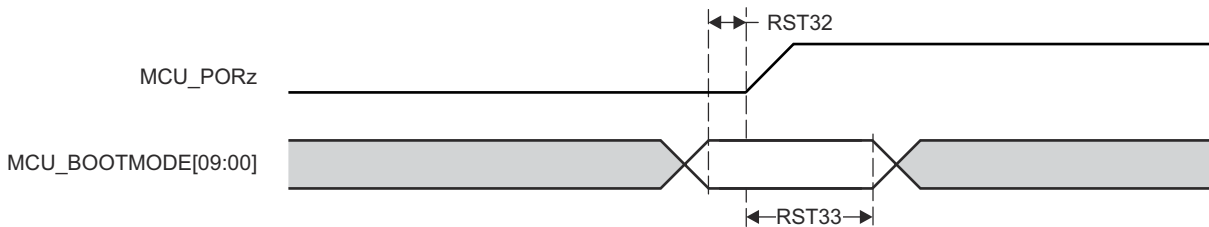

Figure 7-17. MCU_BOOTMODE Timing Requirements

Table 7-16. BOOTMODE Timing Requirements

see [Figure 7-18](#)

NO.			MIN	MAX	UNIT
RST34	$t_{su}(\text{BOOTMODE-PORz})$	Setup time, BOOTMODE[7:0] before PORz high	$3 \cdot S^{(1)}$		ns
RST35	$t_h(\text{PORz - BOOTMODE})$	Hold time, BOOTMODE[7:0] after PORz high	0		ns

(1) S = MCU_OSC0_XI/XO clock period.

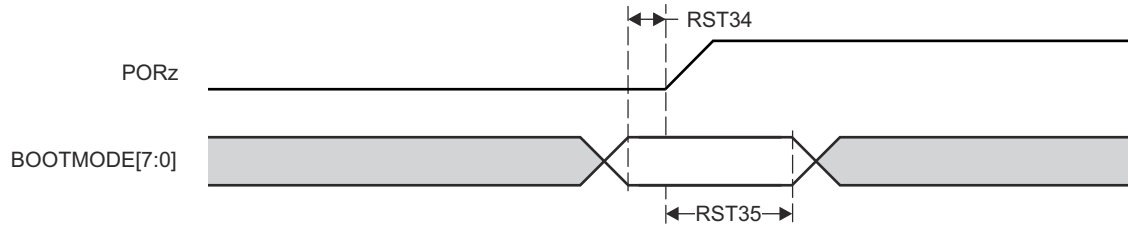

Figure 7-18. BOOTMODE Timing Requirements

7.9.3.2 Safety Signal Timing

Tables and figures provided in this section define switching characteristics for MCU_SAFETY_ERRORn and SOC_SAFETY_ERRORn.

Table 7-17. MCU_SAFETY_ERRORn Switching Characteristics

see [Figure 7-19](#)

NO.	PARAMETER	MIN	MAX	UNIT
SFTY1	$t_{w(MCU_SAFETY_ERRORn)}$ Pulse width minimum, MCU_SAFETY_ERRORn active (PWM mode disabled)	$P \cdot R^{(1) (2)}$		ns
SFTY2	$t_{d(ERROR_CONDITION-MCU_SAFETY_ERRORnL)}$ Delay time, ERROR CONDITION to MCU_SAFETY_ERRORn active	$50 \cdot P^{(1)}$		ns

- (1) P = ESM functional clock (MCU_SYSCLK0 /6).
- (2) R = Error Pin Counter Pre-Load Register count value.

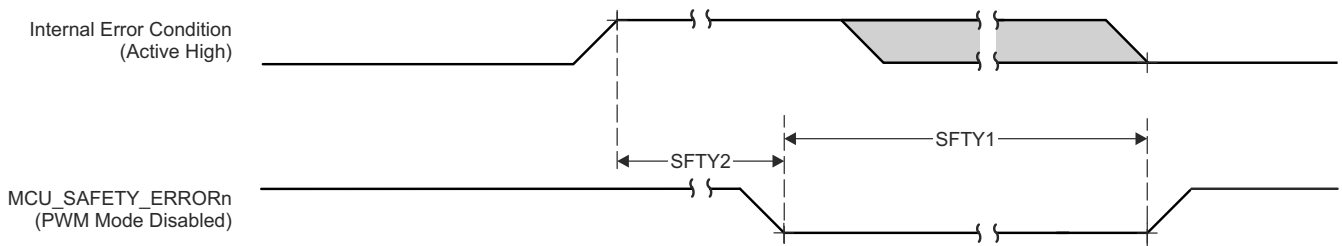

Figure 7-19. MCU_SAFETY_ERRORn Switching Characteristics

Table 7-18. SOC_SAFETY_ERRORn Switching Characteristics

see [Figure 7-20](#)

NO.	PARAMETER	MIN	MAX	UNIT
SFTY3	$t_{w(SOC_SAFETY_ERRORn)}$ Pulse width minimum, SOC_SAFETY_ERRORn active (PWM mode disabled)	$P \cdot R^{(1) (2)}$		ns
SFTY4	$t_{d(ERROR_CONDITION-SOC_SAFETY_ERRORnL)}$ Delay time, ERROR CONDITION to SOC_SAFETY_ERRORn active	$50 \cdot P^{(1)}$		ns

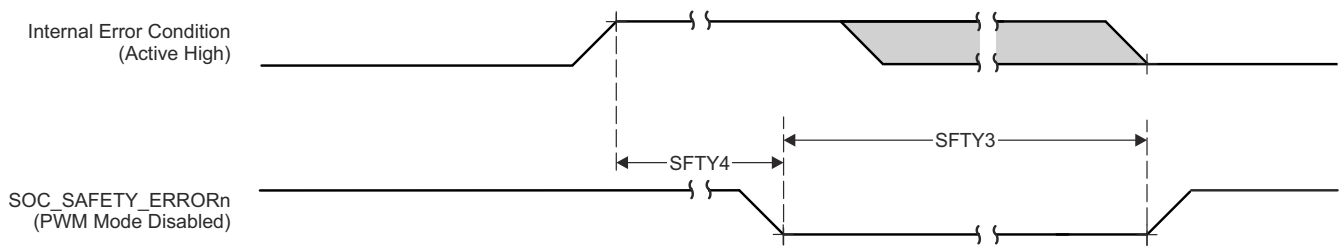

Figure 7-20. SOC_SAFETY_ERRORn Switching Characteristics

7.9.3.3 Clock Timing

Tables and figures provided in this section define timing requirements and switching characteristics for clock signals.

Table 7-19. Clock Timing Requirements

see [Figure 7-21](#)

NO.			MIN	MAX	UNIT
CLK1	$t_{c(EXT_REFCLK1)}$	Cycle time minimum, EXT_REFCLK1	10		ns
CLK2	$t_{w(EXT_REFCLK1H)}$	Pulse Duration minimum, EXT_REFCLK1 high	$E*0.45^{(1)}$	$E*0.55^{(1)}$	ns
CLK3	$t_{w(EXT_REFCLK1L)}$	Pulse Duration minimum, EXT_REFCLK1 low	$E*0.45^{(1)}$	$E*0.55^{(1)}$	ns

(1) E = EXT_REFCLK1 cycle time.

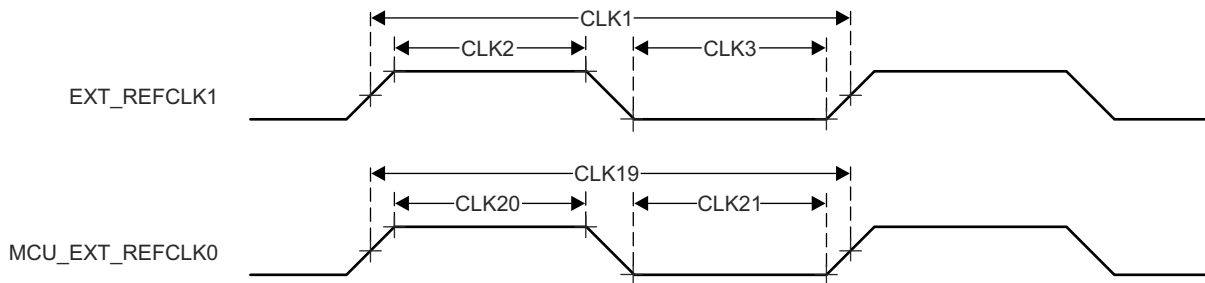

Figure 7-21. Clock Timing Requirements

Table 7-20. Clock Switching Characteristics

see [Figure 7-22](#)

NO.		PARAMETER	MIN	MAX	UNIT
CLK4	$t_{c(SYSCLKOUT0)}$	Cycle time minimum, SYSCLKOUT0	8		ns
CLK5	$t_{w(SYSCLKOUT0H)}$	Pulse Duration minimum, SYSCLKOUT0 high	$A*0.4^{(1)}$	$A*0.6^{(1)}$	ns
CLK6	$t_{w(SYSCLKOUT0L)}$	Pulse Duration minimum, SYSCLKOUT0 low	$A*0.4^{(1)}$	$A*0.6^{(1)}$	ns
CLK7	$t_{c(OBSCLK0)}$	Cycle time minimum, OBSCLK0	5		ns
CLK8	$t_{w(OBSCLK0H)}$	Pulse Duration minimum, OBSCLK0 high	$B*0.4^{(2)}$	$B*0.6^{(2)}$	ns
CLK9	$t_{w(OBSCLK0L)}$	Pulse Duration minimum, OBSCLK0 low	$B*0.4^{(2)}$	$B*0.6^{(2)}$	ns
CLK10	$t_{c(CLKOUT0)}$	Cycle time minimum, CLKOUT0	20		ns
CLK11	$t_{w(CLKOUT0H)}$	Pulse Duration minimum, CLKOUT0 high	$C*0.4^{(3)}$	$C*0.6^{(3)}$	ns
CLK12	$t_{w(CLKOUT0L)}$	Pulse Duration minimum, CLKOUT0 low	$C*0.4^{(3)}$	$C*0.6^{(3)}$	ns

(1) A = SYSCLKOUT0 cycle time.

(2) B = OBSCLK0 cycle time.

(3) C = CLKOUT0 cycle time.

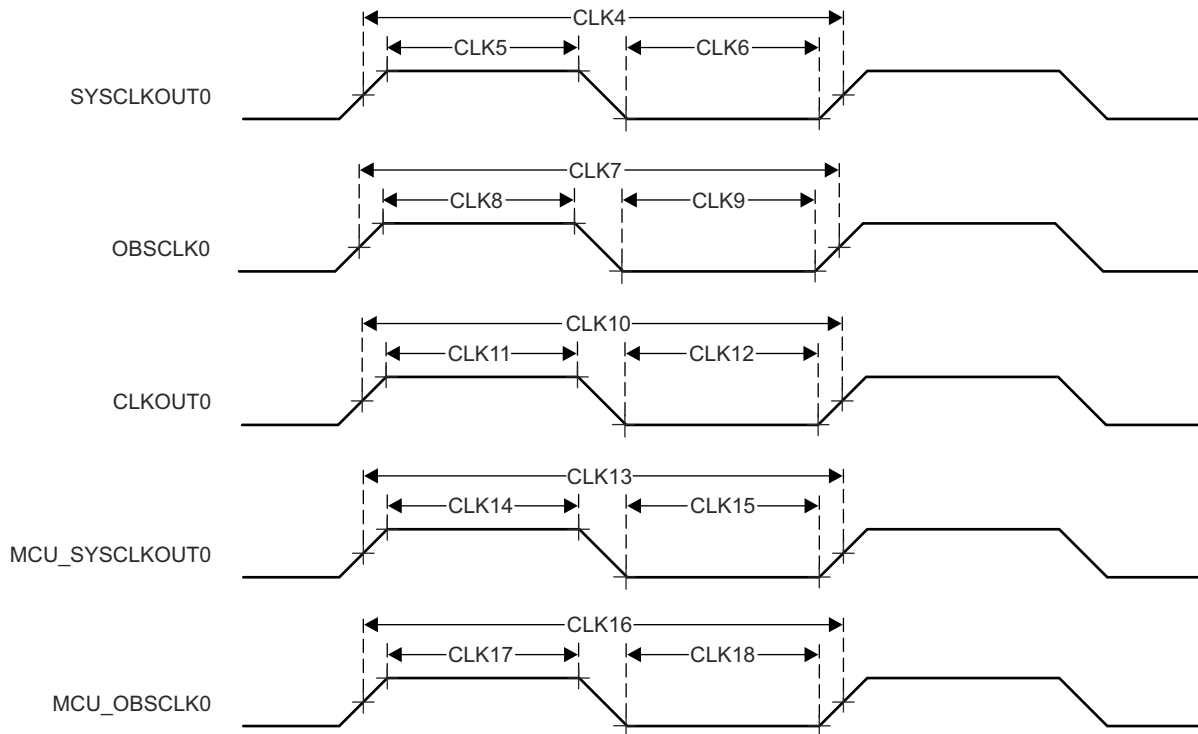

Figure 7-22. Clock Switching Characteristics

7.9.4 Clock Specifications

7.9.4.1 Input Clocks / Oscillators

Various external clock inputs/outputs are needed to drive the device. Summary of these input clock signals is as follows:

- OSC1_XO/OSC1_XI — External main crystal interface pins connected to internal oscillator which sources reference clock and provides reference clock to PLLs within MAIN domain. Also, for audio applications, high-frequency oscillator 0 is used to provide audio clock frequencies to MCASPs.
- High frequency oscillators inputs
 - OSC1_XO/OSC1_XI — external main crystal interface pins connected to internal oscillator which sources reference clock. Provides reference clock to PLLs within MAIN domain. This highfrequency oscillator is used to provide audio clock frequencies to MCASPs.
 - WKUP_OSC0_XO/WKUP_OSC0_XI — external main crystal interface pins of the internal oscillator which sources a reference clock. Provides reference clock to PLLs within WKUP/MCU and MAIN domain.
- Low frequency oscillator input
 - WKUP_LF_CLKIN — External 32.768 kHz clock input.
- General purpose clock inputs
 - MCU_EXT_REFCLK0 — optional external. Provides system clock input (MCU domain).
 - EXT_REFCLK1 — optional external system clock input (MAIN domain). Optionally PLL2 (PER1) and MCASP can be sourced by EXT_REFCLK1 (sourced externally).
 - SERDES0_REFCLK_P/N — SerDes reference clock input for PCIe or Optional USB3 and SGMII interfaces.
- External CPTS reference clock inputs
 - MCU_CPTS0_RFT_CLK — CPTS reference clock inputs for MCU_CPTS_RFT_CLK.
 - CPTS0_RFT_CLK — CPTS reference clock inputs for CPTS_RFT_CLK.
- External audio reference clock input/output pins
 - AUDIO_EXT_REFCLK0
 - AUDIO_EXT_REFCLK1

Figure 7-23 shows the external input clock sources and the output clocks to peripherals.

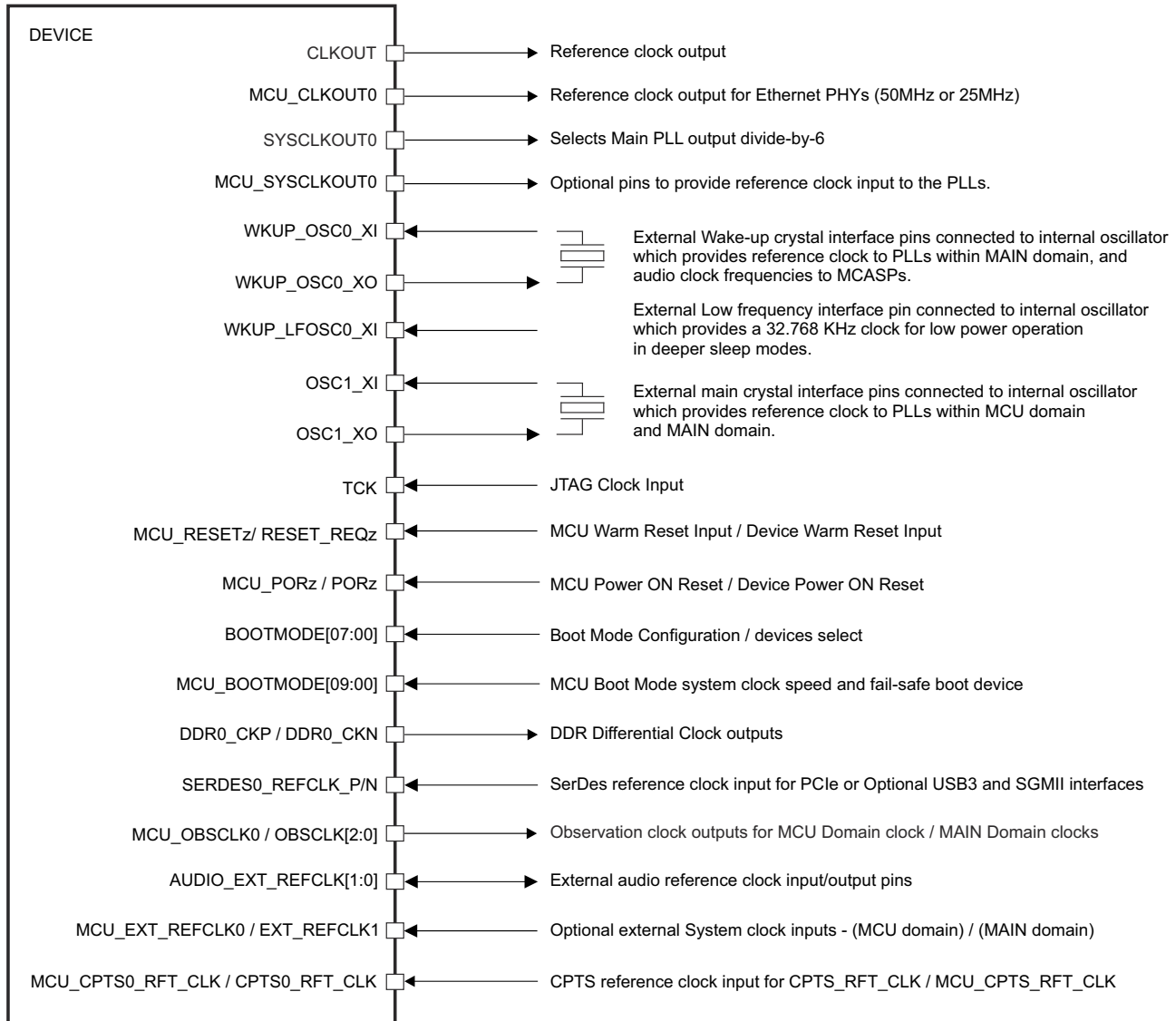

Figure 7-23. Input Clocks Interface

For more information about Input clock interfaces, see *Clocking* section in *Device Configuration* chapter in the device TRM.

7.9.4.1.1 WKUP_OSC0 Internal Oscillator Clock Source

Figure 7-24 shows the recommended crystal circuit. All discrete components used to implement the oscillator circuit should be placed as close as possible to the WKUP_OSC0_XI and WKUP_OSC0_XO pins.

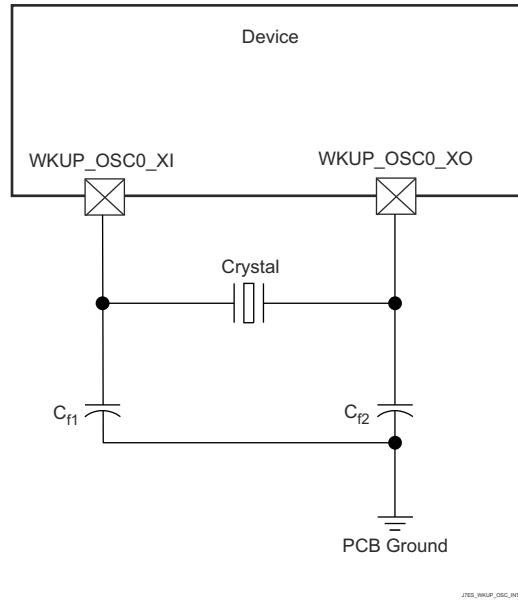

Figure 7-24. WKUP_OSC0 Crystal Implementation

The crystal must be in the fundamental mode of operation and parallel resonant. Table 7-21 summarizes the required electrical constraints.

Table 7-21. WKUP_OSC0 Crystal Circuit Requirements

PARAMETER		MIN	TYP	MAX	UNIT	
F_{xtal}	Crystal Parallel Resonance Frequency	19.2, 20, 24, 25, 26, 27			MHz	
F_{xtal}	Crystal Frequency Stability and Tolerance	Ethernet RGMII and RMII not used		±100	ppm	
		Ethernet RGMII and RMII using derived clock		±50		
$C_{L1+PCBXI}$	Capacitance of $C_{L1} + C_{PCBXI}$	12		24	pF	
$C_{L2+PCBXO}$	Capacitance of $C_{L2} + C_{PCBXO}$	12		24	pF	
C_L	Crystal Load Capacitance	6		12	pF	
C_{shunt}	Crystal Circuit Shunt Capacitance	$ESR_{xtal} = 30 \Omega$	19.2 MHz, 20 MHz, 24 MHz, 25 MHz, 26 MHz, 27 MHz		7	pF
		$ESR_{xtal} = 40 \Omega$	19.2 MHz, 20 MHz, 24 MHz, 25 MHz, 26 MHz, 27 MHz		5	pF
		$ESR_{xtal} = 50 \Omega$	19.2 MHz, 20 MHz, 24 MHz, 25 MHz, 26 MHz, 27 MHz		5	pF
		$ESR_{xtal} = 60 \Omega$	19.2 MHz, 20 MHz, 24 MHz		5	pF
		$ESR_{xtal} = 80 \Omega$	19.2 MHz, 20 MHz		5	pF
			25 MHz		3	pF
$ESR_{xtal} = 100 \Omega$	19.2 MHz, 20 MHz		3	pF		
ESR_{xtal}	Crystal Effective Series Resistance			100	Ω	

When selecting a crystal, the system design must consider temperature and aging characteristics of the crystal based on worst case environment and expected life expectancy of the system.

Table 7-22 details the switching characteristics of the oscillator.

Table 7-22. WKUP_OSC0 Switching Characteristics – Crystal Mode

NAME	DESCRIPTION	MIN	TYP	MAX	UNIT
C _{XI}	XI Capacitance			1.55	pF
C _{XO}	XO Capacitance			1.35	pF
C _{XIXO}	XI to XO Mutual Capacitance			0.01	pF
t _s	Start-up Time		9.5 ⁽¹⁾		ms

- (1) TI strongly encourages each customer to submit samples of the device to the resonator/crystal vendors for validation. The vendors are equipped to determine what load capacitors will best tune their resonator/crystal to the microcontroller device for optimum startup and operation over temperature/voltage extremes.

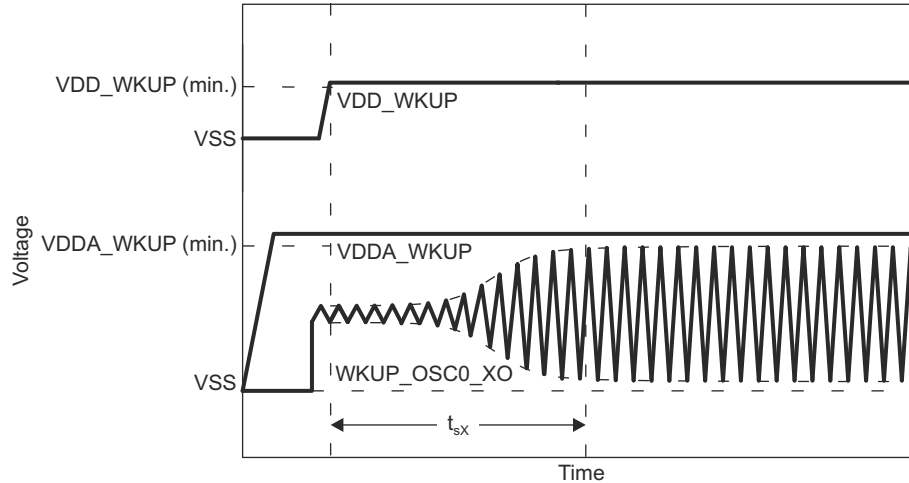

Figure 7-25. WKUP_OSC0 Start-up Time

7.9.4.1.1.1 Load Capacitance

The crystal circuit must be designed such that it applies the appropriate capacitive load to the crystal, as defined by the crystal manufacturer. The capacitive load, C_L, of this circuit is a combination of discrete capacitors C_{L1}, C_{L2}, and several parasitic contributions. PCB signal traces which connect crystal circuit components to WKUP_OSC0_XI and WKUP_OSC0_XO have parasitic capacitance to ground, C_{PCBXI} and C_{PCBXO}, where the PCB designer should be able to extract parasitic capacitance for each signal trace. The WKUP_OSC0 circuits and device package have combined parasitic capacitance to ground, C_{PCBXI} and C_{PCBXO}, where these parasitic capacitance values are defined in Table 7-22.

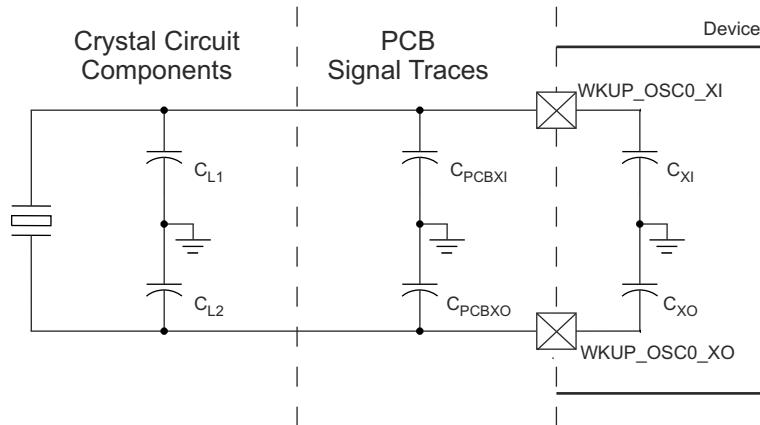

Figure 7-26. Load Capacitance

Load capacitors, C_{L1} and C_{L2} in Figure 7-24, should be chosen such that the below equation is satisfied. C_L in the equation is the load specified by the crystal manufacturer.

$$C_L = [(C_{L1} + C_{PCBXI} + C_{XI}) \times (C_{L2} + C_{PCBXO} + C_{XO})] / [(C_{L1} + C_{PCBXI} + C_{XI}) + (C_{L2} + C_{PCBXO} + C_{XO})]$$

To determine the value of C_{L1} and C_{L2} , multiply the capacitive load value C_L by 2. Using this result, subtract the combined values of $C_{PCBXI} + C_{XI}$ to determine the value of C_{L1} and the combined values of $C_{PCBXO} + C_{XO}$ to determine the value of C_{L2} . For example, if $C_L = 10$ pF, $C_{PCBXI} = 2.9$ pF, $C_{XI} = 0.5$ pF, $C_{PCBXO} = 3.7$ pF, $C_{XO} = 0.5$ pF, the value of $C_{L1} = [(2C_L) - (C_{PCBXI} + C_{XI})] = [(2 \times 10 \text{ pF}) - 2.9 \text{ pF} - 0.5 \text{ pF}] = 16.6$ pF and $C_{L2} = [(2C_L) - (C_{PCBXO} + C_{XO})] = [(2 \times 10 \text{ pF}) - 3.7 \text{ pF} - 0.5 \text{ pF}] = 15.8$ pF

7.9.4.1.1.2 Shunt Capacitance

The crystal circuit must also be designed such that it does not exceed the maximum shunt capacitance for WKUP_OSC0 operating conditions defined in Table 7-21. Shunt capacitance, C_{shunt} , of the crystal circuit is a combination of crystal shunt capacitance and parasitic contributions. PCB signal traces which connect crystal circuit components to WKUP_OSC0 have mutual parasitic capacitance to each other, $C_{PCBXIXO}$, where the PCB designer should be able to extract mutual parasitic capacitance between these signal traces. The device package also has mutual parasitic capacitance, C_{XIXO} , where this mutual parasitic capacitance value is defined in Table 7-22.

PCB routing should be designed to minimize mutual capacitance between XI and XO signal traces. This is typically done by keeping signal traces short and not routing them in close proximity. Mutual capacitance can also be minimized by placing a ground trace between these signals when the layout requires them to be routed in close proximity. It is important to minimize the mutual capacitance on the PCB to provide as much margin as possible when selecting a crystal.

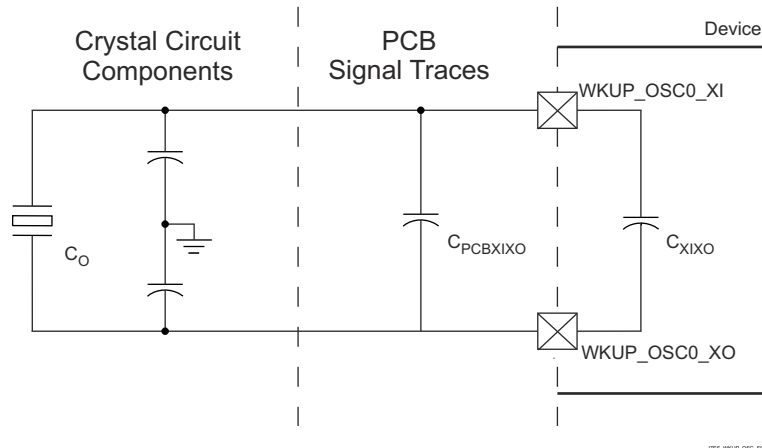

Figure 7-27. Shunt Capacitance

A crystal should be chosen such that the below equation is satisfied. C_0 in the equation is the maximum shunt capacitance specified by the crystal manufacturer.

$$C_{shunt} \geq C_0 + C_{PCBXIXO} + C_{XIXO}$$

For example, the equation would be satisfied when the crystal being used is 25 MHz with an ESR = 30 Ω , $C_{PCBXIXO} = 0.04$ pF, $C_{XIXO} = 0.01$ pF, and shunt capacitance of the crystal is less than or equal to 6.95 pF.

7.9.4.1.2 WKUP_OSC0 LVC MOS Digital Clock Source

Figure 7-28 shows the recommended oscillator connections when WKUP_OSC0_XI is connected to a 1.8-V LVC MOS square-wave digital clock source.

Note

A DC steady-state condition is not allowed on WKUP_OSC0_XI when the oscillator is powered up. This is not allowed because WKUP_OSC0_XI is internally AC coupled to a comparator that may enter a unknown state when DC is applied to the input. Therefore, application software should power down WKUP_OSC0 any time WKUP_OSC0_XI is not toggling between logic states.

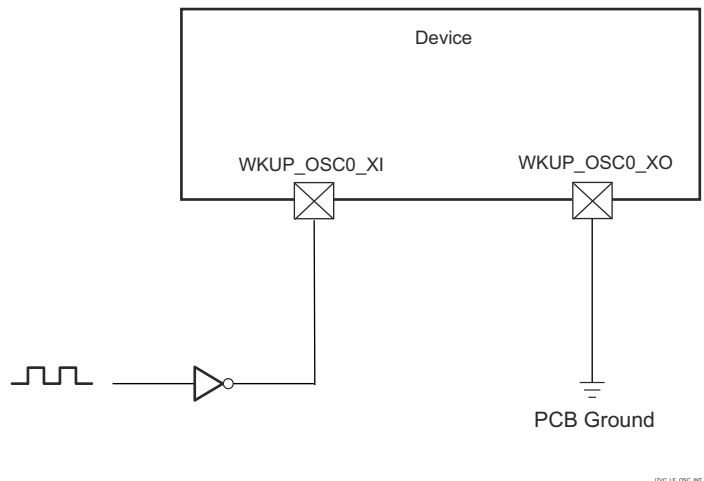

Figure 7-28. 1.8-V LVCMOS-Compatible Clock Input

7.9.4.1.3 Auxiliary OSC1 Internal Oscillator Clock Source

Figure 7-29 shows the recommended crystal circuit. All discrete components used to implement the oscillator circuit should be placed as close as possible to the OSC1_XI and OSC1_XO pins.

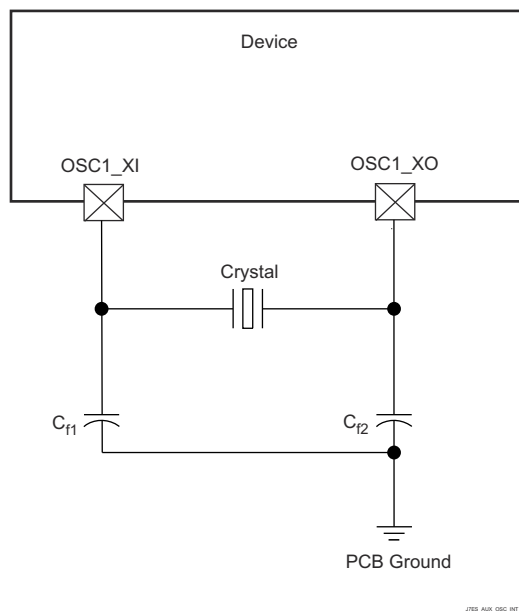

Figure 7-29. OSC1 Crystal Implementation

The crystal must be in the fundamental mode of operation and parallel resonant. Table 7-23 summarizes the required electrical constraints.

Table 7-23. OSC1 Crystal Electrical Characteristics

PARAMETER		MIN	TYP	MAX	UNIT
F _{xtal}	Crystal Parallel Resonance Frequency	19.2		27	MHz
F _{xtal}	Crystal Frequency Stability and Tolerance	Ethernet RGMII and RMII not used		±100	ppm
		Ethernet RGMII and RMII using derived clock		±50	
C _{L1+PCBXI}	Capacitance of C _{L1} + C _{PCBXI}	12		24	pF
C _{L2+PCBXO}	Capacitance of C _{L2} + C _{PCBXO}	12		24	pF
C _L	Crystal Load Capacitance	6		12	pF
C _{shunt}	Crystal Circuit Shunt Capacitance	ESR _{xtal} = 30 Ω	19.2 MHz, 20 MHz, 24 MHz, 25 MHz, 26 MHz, 27 MHz	7	pF
		ESR _{xtal} = 40 Ω	19.2 MHz, 20 MHz, 24 MHz, 25 MHz, 26 MHz, 27 MHz	5	pF
		ESR _{xtal} = 50 Ω	19.2 MHz, 20 MHz, 24 MHz, 25 MHz, 26 MHz, 27 MHz	5	pF
		ESR _{xtal} = 60 Ω	19.2 MHz, 20 MHz, 24 MHz	5	pF
		ESR _{xtal} = 80 Ω	19.2 MHz, 20 MHz	5	pF
			25 MHz	3	pF
		ESR _{xtal} = 100 Ω	19.2 MHz, 20 MHz	3	pF
ESR _{xtal}	Crystal Effective Series Resistance			100	Ω

When selecting a crystal, the system design must consider the temperature and aging characteristics of a based on the worst case environment and expected life expectancy of the system.

Table 7-24 details the switching characteristics of the oscillator and the requirements of the input clock.

Table 7-24. OSC1 Switching Characteristics – Crystal Mode

PARAMETER		MIN	TYP	MAX	UNIT
C _{XI}	XI Capacitance			1.55	pF
C _{XO}	XO Capacitance			1.35	pF
C _{XIXO}	XI to XO Mutual Capacitance			0.01	pF
t _s	Start-up Time		9.5 ⁽¹⁾		ms

- (1) TI strongly encourages each customer to submit samples of the device to the resonator/crystal vendors for validation. The vendors are equipped to determine what load capacitors will best tune their resonator/crystal to the microcontroller device for optimum startup and operation over temperature/voltage extremes.

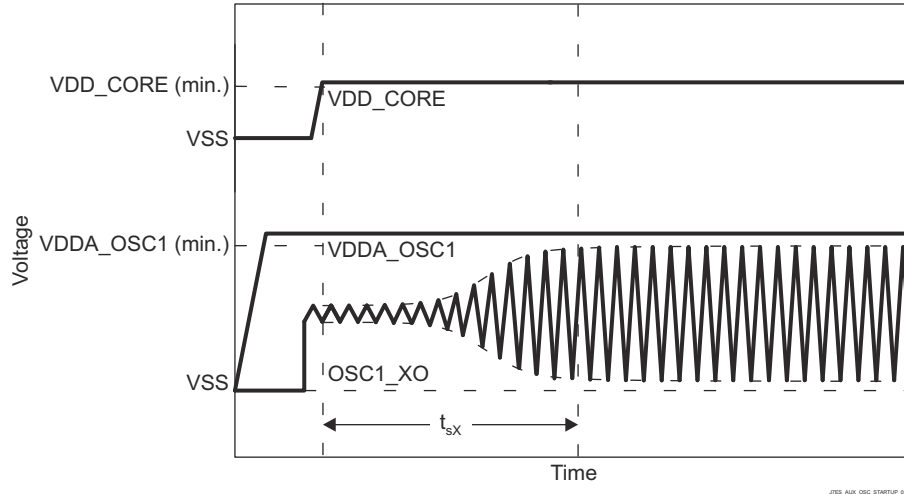

Figure 7-30. OSC1 Start-up Time

7.9.4.1.3.1 Load Capacitance

The crystal circuit must be designed such that it applies the appropriate capacitive load to the crystal, as defined by the crystal manufacturer. The capacitive load, C_L , of this circuit is a combination of discrete capacitors C_{L1} , C_{L2} , and several parasitic contributions. PCB signal traces which connect crystal circuit components to OSC1_XI and OSC1_XO have parasitic capacitance to ground, C_{PCBXI} and C_{PCBXO} , where the PCB designer should be able to extract parasitic capacitance for each signal trace. The OSC1 circuits and device package have combined parasitic capacitance to ground, C_{PCBXI} and C_{PCBXO} , where these parasitic capacitance values are defined in [Table 7-22](#).

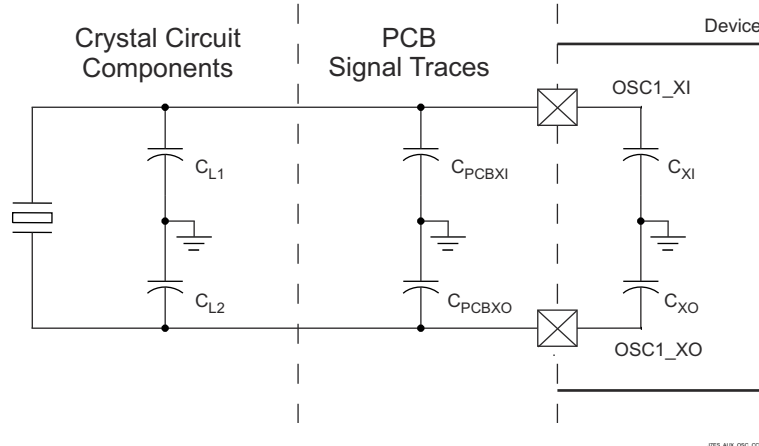

Figure 7-31. Load Capacitance

Load capacitors, C_{L1} and C_{L2} in [Figure 7-24](#), should be chosen such that the below equation is satisfied. C_L in the equation is the load specified by the crystal manufacturer.

$$C_L = [(C_{L1} + C_{PCBXI} + C_{XI}) \times (C_{L2} + C_{PCBXO} + C_{XO})] / [(C_{L1} + C_{PCBXI} + C_{XI}) + (C_{L2} + C_{PCBXO} + C_{XO})]$$

To determine the value of C_{L1} and C_{L2} , multiply the capacitive load value C_L by 2. Using this result, subtract the combined values of $C_{PCBXI} + C_{XI}$ to determine the value of C_{L1} and the combined values of $C_{PCBXO} + C_{XO}$ to determine the value of C_{L2} . For example, if $C_L = 10$ pF, $C_{PCBXI} = 2$ pF, $C_{XI} = 1$ pF, $C_{PCBXO} = 2$ pF, $C_{XO} = 1$ pF, the value of $C_{L1} = C_{L2} = [(2C_L) - (C_{PCBXI} + C_{XI})] = [(2C_L) - (C_{PCBXO} + C_{XO})] = [(2 \times 10 \text{ pF}) - 2 \text{ pF} - 1 \text{ pF}] = 17$ pF.

7.9.4.1.3.2 Shunt Capacitance

The crystal circuit must also be designed such that it does not exceed the maximum shunt capacitance for OSC1 operating conditions defined in [Table 7-21](#). Shunt capacitance, C_{shunt} , of the crystal circuit is a

combination of crystal shunt capacitance and parasitic contributions. PCB signal traces which connect crystal circuit components to OSC1 have mutual parasitic capacitance to each other, $C_{PCBXIXO}$, where the PCB designer should be able to extract mutual parasitic capacitance between these signal traces. The device package also has mutual parasitic capacitance, C_{XIXO} , where this mutual parasitic capacitance value is defined in [Table 7-22](#).

PCB routing should be designed to minimize mutual capacitance between XI and XO signal traces. This is typically done by keeping signal traces short and not routing them in close proximity. Mutual capacitance can also be minimized by placing a ground trace between these signals when the layout requires them to be routed in close proximity. It is important to minimize the mutual capacitance on the PCB to provide as much margin as possible when selecting a crystal.

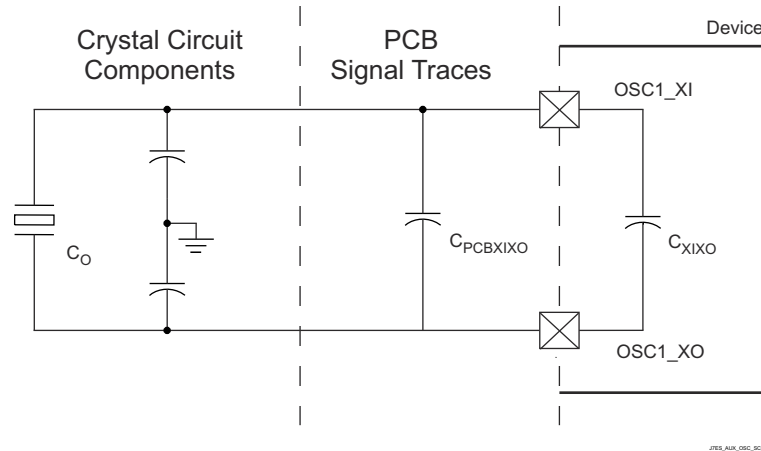

Figure 7-32. Shunt Capacitance

A crystal should be chosen such that the below equation is satisfied. C_O in the equation is the maximum shunt capacitance specified by the crystal manufacturer.

$$C_{shunt} \geq C_O + C_{PCBXIXO} + C_{XIXO}$$

For example, the equation would be satisfied when the crystal being used is 25 MHz with an ESR = 30 Ω , $C_{PCBXIXO} = 0.7$ pF, $C_{XIXO} = 0.01$ pF, and shunt capacitance of the crystal is less than or equal to 6.29 pF.

7.9.4.1.4 Auxiliary OSC1 LVCMOS Digital Clock Source

[Figure 7-33](#) shows the recommended oscillator connections when OSC1_XI is connected to a 1.8-V LVCMOS square-wave digital clock source.

Note

A DC steady-state condition is not allowed on OSC1_XI when the oscillator is powered up. This is not allowed because OSC1_XI is internally AC coupled to a comparator that may enter a unknown state when DC is applied to the input. Therefore, application software should power down OSC1 any time OSC1_XI is not toggling between logic states.

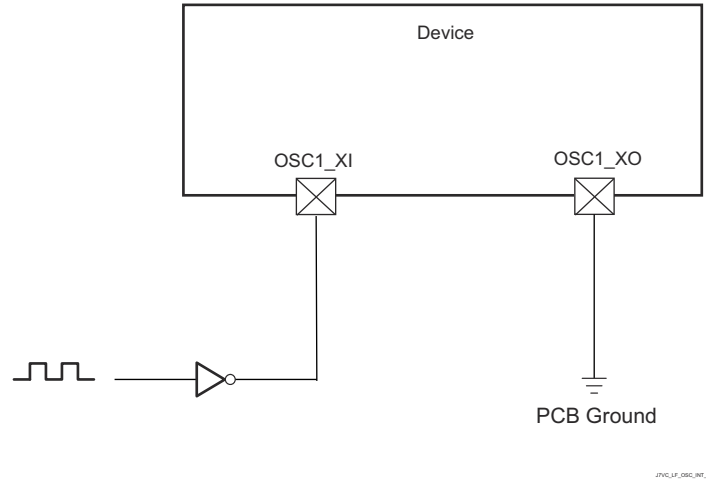

Figure 7-33. 1.8-V LVCMOS-Compatible Clock Input

7.9.4.1.5 Auxiliary OSC1 Not Used

Figure 7-34 shows the recommended oscillator connections when OSC1 is not used. OSC1_XI must be connected to VSS through an external pull resistor (R_{pd}) to ensure this input is held to a valid low level when unused since the internal pull-down resistor is disabled by default.

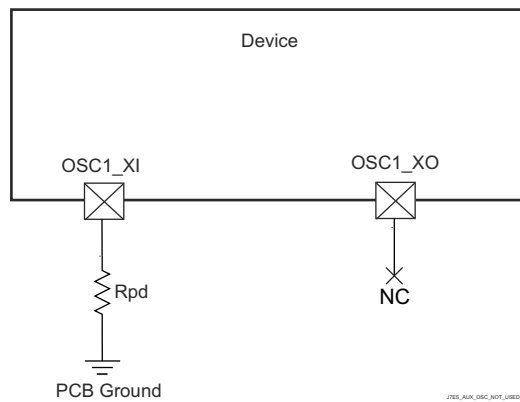

Figure 7-34. OSC1 Not Used

7.9.4.1.6 WKUP_LF_CLKIN Internal Oscillator Clock Source

Figure 7-35 shows the recommended oscillator connections when WKUP_LF_CLKIN is connected to an LVCMOS square-wave digital clock source.

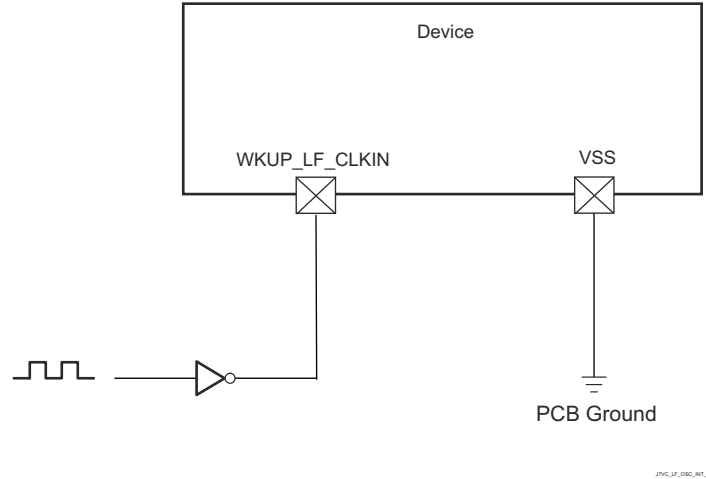

Figure 7-35. WKUP_LF_CLKIN Crystal Implementation

Table 7-25 details the WKUP_LF_CLKIN input clock timing requirements..

Table 7-25. WKUP_LF_CLKIN Input Clock Timing Requirements⁽²⁾

NAME	DESCRIPTION	MIN	TYP	MAX	UNIT
CK0	1 / $t_c(\text{WKUP_LF_CLKIN})$ Frequency, WKUP_LF_CLKIN		32768		Hz
CK1	$t_w(\text{WKUP_LF_CLKIN})$ Pulse duration, WKUP_LF_CLKIN low or high	0.45*P ⁽¹⁾		0.55*P ⁽¹⁾	ns

(1) P is WKUP_LF_CLKIN cycle time in ns.

(2) Refer to Section 7.6.7 LVC MOS Electrical Characteristics for voltage and slew rate information.

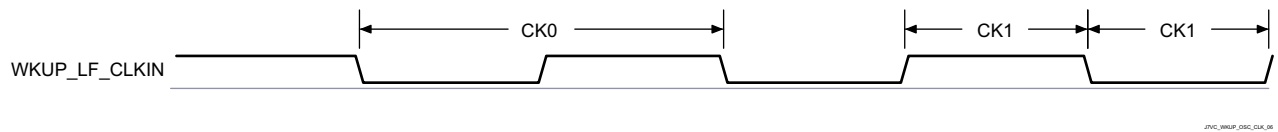

Figure 7-36. WKUP_LF_CLKIN Start-up Time

7.9.4.1.7 WKUP_LF_CLKIN Not Used

Figure 7-37 shows the recommended oscillator connections when WKUP_LF_CLKIN is not used. WKUP_LF_CLKIN may be a no-connect while the oscillator remains disabled since the internal pull-down resistor is enabled by default.

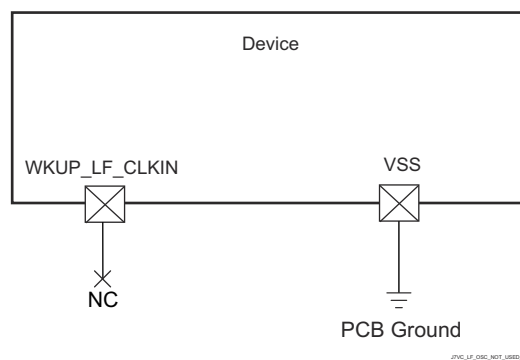

Figure 7-37. WKUP_LF_CLKIN Not Used

7.9.4.2 Output Clocks

The device provides several system clock outputs. Summary of these output clocks are as follows:

- **MCU_CLKOUT0**
 - Reference clock output for Ethernet PHYs (50 MHz or 25 MHz)
- **MCU_SYSCLKOUT0**
 - SYSCLK0 of WKUP_PLLCTRL0 is divided by 6 and then sent out of the device as a LVCMOS clock signal (MCU_SYSCLKOUT0). This signal can be used to test if the main chip clock is functioning or not.
- **MCU_OBSCLK0**
 - On the clock output MCU_OBSCLK0, oscillators and PLLs clocks can be observed for tests and debug.
- **SYSCLKOUT0**
 - SYSCLK0 from the MAIN_PLL controller is divided by 6 and then sent out of the device as a LVCMOS clock signal (SYSCLKOUT0). This signal can be used to test if the main chip clock is functioning or not.
- **CLKOUT**
 - Reference clock output
- **OBSCLK[2:0]**
 - On the clock output OBSCLK0, oscillators and PLLs clocks can be observed for tests and debug.

7.9.4.3 PLLs

Power is supplied to the Phase-Locked Loop circuitries (PLLs) by internal regulators that derive their power from off-chip power sources.

There are total of three PLLs in the device in WKUP and MCU domains:

- MCU_PLL0 (MCU R5FSS PLL) with WKUP_PLLCTRL0
- MCU_PLL1 (MCU PERIPHERAL PLL)
- MCU_PLL2 (MCU CPSW PLL)

There are total of ten PLLs in MAIN domain:

- PLL0 (MAIN PLL) with PLLCTRL0
- PLL1 (PER0 PLL)
- PLL2 (PER1 PLL)
- PLL3 (CPSW5X PLL)
- PLL4 (AUDIO0 PLL)
- PLL7 (MSMC PLL)
- PLL8 (ARM0 PLL)
- PLL12 (DDR PLL)
- PLL13 (C66 PLL)
- PLL14 (R5FSS PLL)

Note

For more information, see:

- *Device Configuration / Clocking / PLLs* section in the device TRM.
 - *Programmable Real-Time Unit Subsystem and Industrial Communication Subsystem - Gigabit (PRU)* section in the device TRM.
-

Note

The input reference clock (OSC1_XI/OSC1_XO) is specified and the lock time is ensured by the PLL controller, as documented in the *Device Configuration* chapter in the device TRM.

7.9.4.4 Recommended Clock and Control Signal Transition Behavior

All clocks and strobe signals must transition between V_{IH} and V_{IL} (or between V_{IL} and V_{IH}) in a monotonic manner. Monotonic transitions are more easily ensured with faster switching signals. Slower input transitions are more susceptible to glitches due to noise, and special care must be taken for slow input clocks.

7.9.4.5 Interface Clock Specifications

7.9.4.5.1 Interface Clock Terminology

The interface clock is used at the system level to sequence the data and to control transfers accordingly with the interface protocol.

7.9.4.5.2 Interface Clock Frequency

The two interface clock characteristics are:

- The maximum clock frequency
- The maximum operating frequency

The interface clock frequency documented here is the maximum clock frequency, which corresponds to the maximum frequency programmable on this output clock. This frequency defines the maximum limit supported by the Device IC and does not take into account any system consideration (PCB, peripherals).

The system designer must take into account these system considerations and the Device IC timing characteristics to properly define the maximum operating frequency that corresponds to the maximum frequency supported to transfer the data on this interface.

7.9.5 Peripherals

7.9.5.1 ATL

The device contains ATL module that can be used for asynchronous sample rate conversion of audio. The ATL calculates the error between two time bases, such as audio syncs, and optionally generates an averaged clock using cycle stealing via software.

Note

For more information about ATL, see *Audio Tracking Logic (ATL)* section in *Peripherals* chapter in the device TRM.

Table 7-26 represents ATL timing conditions.

Table 7-26. ATL Timing Conditions

PARAMETER		MODE	MIN	MAX	UNIT
INPUT CONDITIONS					
SR _I	Input slew rate	External reference CLK	0.5	5	V/ns
OUTPUT CONDITIONS					
C _L	Output load capacitance	Internal reference CLK	1	10	pF

Section 7.9.5.1.1, Section 7.9.5.1.2, Section 7.9.5.1.3, and Section 7.9.5.1.4 present timing requirements and switching characteristics for ATL.

7.9.5.1.1 ATL_PCLK Timing Requirements

NO.	PARAMETER		MODE	MIN	MAX	UNIT
D1	t _{c(pclk)}	Cycle time, ATL_PCLK	External reference CLK	5		ns
D2	t _{w(pclkL)}	Pulse Duration, ATL_PCLK low	External reference CLK	0.45 × M ⁽¹⁾ + 2.5		ns
D3	t _{w(pclkH)}	Pulse Duration, ATL_PCLK high	External reference CLK	0.45 × M ⁽¹⁾ + 2.5		ns

(1) M = ATL_CLK[x] period

7.9.5.1.2 ATL_AWS[x] Timing Requirements

NO.	PARAMETER		MODE	MIN	MAX	UNIT
D4	t _{c(aws)}	Cycle Time, ATL_AWS[x] ⁽³⁾	External reference CLK	2 × M ⁽¹⁾		ns
D5	t _{w(awsL)}	Pulse Duration, ATL_AWS[x] ⁽³⁾ low	External reference CLK	0.45 × A ⁽²⁾ + 2.5		ns
D6	t _{w(awsH)}	Pulse Duration, ATL_AWS[x] ⁽³⁾ high	External reference CLK	0.45 × A ⁽²⁾ + 2.5		ns

(1) M = ATL_CLK[x] period

(2) A = ATL_AWS[x] period

(3) x = 0 to 3

7.9.5.1.3 ATL_BWS[x] Timing Requirements

NO.	PARAMETER		MODE	MIN	MAX	UNIT
D7	t _{c(bws)}	Cycle Time, ATL_BWS[x] ⁽³⁾	External reference clock	2 × M ⁽¹⁾		ns
D8	t _{w(bwsL)}	Pulse Duration, ATL_BWS[x] low ⁽³⁾	External reference clock	0.45 × B ⁽²⁾ + 2.5		ns

NO.			MODE	MIN	MAX	UNIT
D9	$t_{w(bwsH)}$	Pulse Duration, ATL_BWS[x] high ⁽³⁾	External reference clock	$0.45 \times B^{(2)} + 2.5$		ns

- (1) M = ATL_CLK[x] period
(2) B = ATL_BWS[x] period
(3) x = 0 to 3

7.9.5.1.4 ATCLK[x] Switching Characteristics

NO.	PARAMETER		MODE	MIN	MAX	UNIT
D10	$t_{c(atclk)}$	Cycle time, ATCLK[x] ⁽³⁾	Internal reference CLK	20		ns
D11	$t_{w(atclkL)}$	Pulse Duration, ATCLK[x] low ⁽³⁾	Internal reference CLK	$0.45 \times P^{(2)} - M^{(1)} - 0.3$		ns
D12	$t_{w(atclkH)}$	Pulse Duration, ATCLK[x] high ⁽³⁾	Internal reference CLK	$0.45 \times P^{(2)} - M^{(1)} - 0.3$		ns

- (1) M = ATL_CLK[x] period
(2) P = ATCLK[x] period
(3) x = 0 to 3

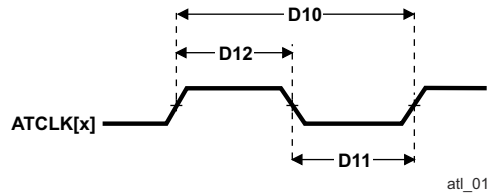

Figure 7-38. ATCLK[x] Timing

7.9.5.2 CPSW2G

For more details about features and additional description information on the device Gigabit Ethernet MAC, see the corresponding sections within [Section 6.3, Signal Descriptions](#) and [Section 8, Detailed Description](#).

[Table 7-27](#) represents CPSW2G timing conditions.

Table 7-27. CPSW2G Timing Conditions

PARAMETER	DESCRIPTION		MIN	MAX	UNIT
INPUT CONDITIONS					
t_R	Input signal rise time		1	5	V/ns
t_F	Input signal fall time		1	5	V/ns
OUTPUT CONDITIONS					
C_{LOAD}	Output load capacitance		2	20	pF
PCB CONNECTIVITY REQUIREMENTS					
t_d (Trace Mismatch Delay)	Propagation delay mismatch across all traces	RGMII[x]_RXC, RGMII[x]_RD[3:0], RGMII[x]_RX_CTL		50	ps
		RGMII[x]_TXC, RGMII[x]_TD[3:0], RGMII[x]_TX_CTL		50	ps

7.9.5.2.1 CPSW2G RMII Timings

[Section 7.9.5.2.1.1](#), [Section 7.9.5.2.1.2](#), and [Figure 7-39](#) present timing requirements for CPSW2G RMII receive.

7.9.5.2.1.1 Timing Requirements for RMII[x]_REFCLK – RMII Mode

NO.	PARAMETER	DESCRIPTION	MIN	TYP	MAX	UNIT
RMII1	$t_{c(REF_CLK)}$	Cycle time, REF_CLK	19.999	20.001		ns

NO.	PARAMETER	DESCRIPTION	MIN	TYP	MAX	UNIT
RMII2	$t_w(\text{REF_CLKH})$	Pulse Duration, REF_CLK High	7		13	ns
RMII3	$t_w(\text{REF_CLKL})$	Pulse Duration, REF_CLK Low	7		13	ns

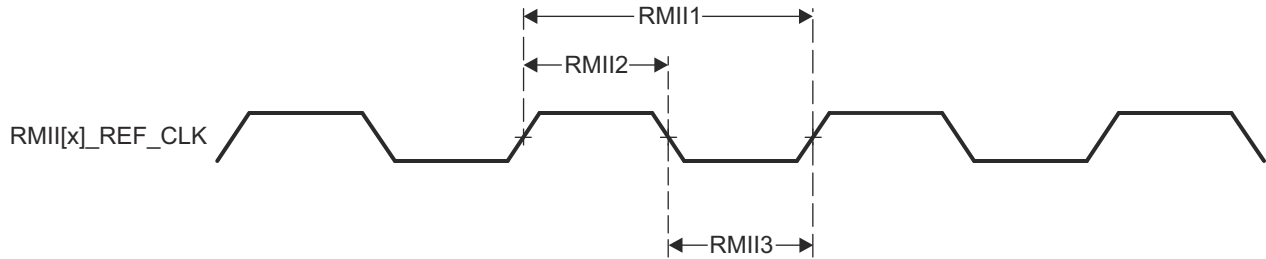

Figure 7-39. RMII[x]_REFCLK Timing – RMII Mode

7.9.5.2.1.2 Timing Requirements for RMII[x]_RXD[1:0], RMII[x]_CRS_DV, and RMII[x]_RXER – RMII Mode

NO.	PARAMETER	DESCRIPTION	MIN	TYP	MAX	UNIT
RMII4	$t_{su}(\text{RXD-REF_CLK})$	Setup time, RXD[1:0] valid before REF_CLK	4			ns
	$t_{su}(\text{CRS_DV-REF_CLK})$	Setup time, CRS_DV valid before REF_CLK	4			ns
	$t_{su}(\text{RX_ER-REF_CLK})$	Setup time, RX_ER valid before REF_CLK	4			ns
RMII5	$t_h(\text{REF_CLK-RXD})$	Hold time RXD[1:0] valid after REF_CLK	2			ns
	$t_h(\text{REF_CLK-CRS_DV})$	Hold time, CRS_DV valid after REF_CLK	2			ns
	$t_h(\text{REF_CLK-RX_ER})$	Hold time, RX_ER valid after REF_CLK	2			ns

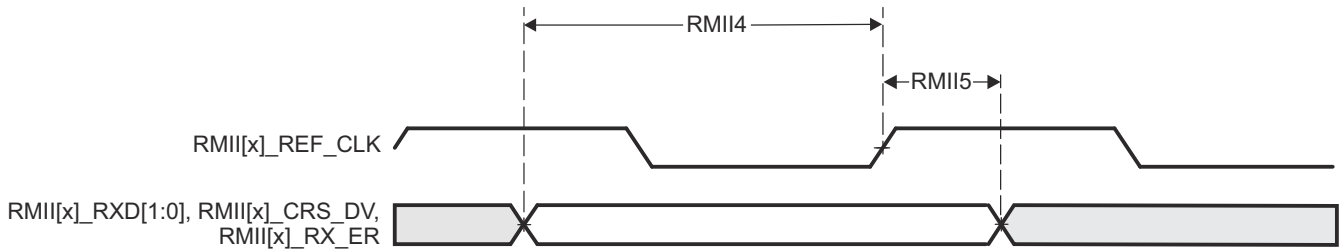
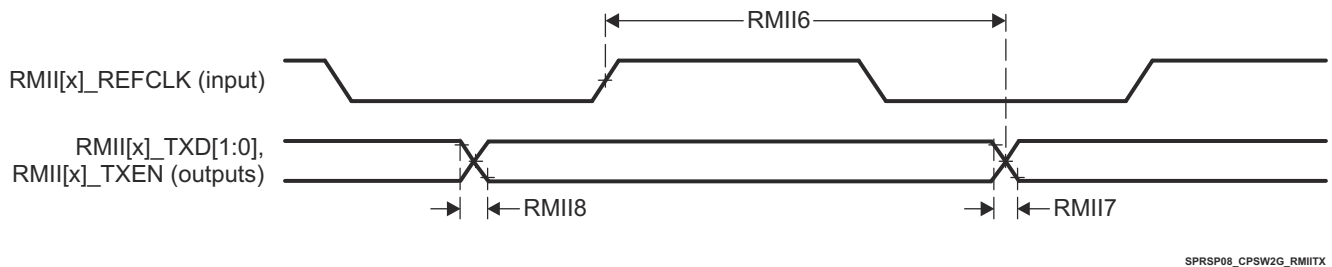

Figure 7-40. RMII[x]_RXD[1:0], RMII[x]_CRS_DV, RMII[x]_RXER Timing – RMII Mode

Section 7.9.5.2.1.3, and Section 7.9.5.2.1.3, present switching characteristics for CPSW2G RMII Transmit.

7.9.5.2.1.3 Switching Characteristics for RMII[x]_TXD[1:0], and RMII[x]_TXEN – RMII Mode

NO.	PARAMETER	DESCRIPTION	MIN	TYP	MAX	UNIT
RMII6	$t_d(\text{REF_CLK-TXD})$	Delay time, REF_CLK High to TXD[1:0] valid	2		10	ns
	$t_d(\text{REF_CLK-TXEN})$	Delay time, REF_CLK to TXEN valid	2		10	ns
RMII7	$t_r(\text{TXD})$	Rise Time, TXD Outputs	1		5	ns
	$t_r(\text{TX_EN})$	Rise Time, TX_EN Output	1		5	ns
RMII8	$t_f(\text{TXD})$	Fall Time, TXD Outputs	1		5	ns
	$t_f(\text{TX_EN})$	Fall Time, TX_EN Output	1		5	ns



SPRSP08_CPSW2G_RMII7X

Figure 7-41. SPI Master Mode Receive Timing

7.9.5.2.2 CPSW2G RGMII Timings

Section 7.9.5.2.2.1, Section 7.9.5.2.2.2, and Figure 7-42 present timing requirements for receive RGMII operation.

7.9.5.2.2.1 Timing Requirements for RGMII[x]_RCLK – RGMII Mode

NO.	PARAMETER	DESCRIPTION	MODE	MIN	TYP	MAX	UNIT
RGMII1	$t_{c(RXC)}$	Cycle time, RXC	10Mbps	360		440	ns
			100Mbps	36		44	ns
			1000Mbps	7.2		8.8	ns
RGMII2	$t_{w(RXCH)}$	Pulse duration, RXC high	10Mbps	160		240	ns
			100Mbps	16		24	ns
			1000Mbps	3.6		4.4	ns
RGMII3	$t_{w(RXCL)}$	Pulse duration, RXC low	10Mbps	160		240	ns
			100Mbps	16		24	ns
			1000Mbps	3.6		4.4	ns
RGMII4	$t_{t(RXC)}$	Transition time, RXC	10Mbps			0.75	ns
			100Mbps			0.75	ns
			1000Mbps			0.75	ns

7.9.5.2.2.2 Timing Requirements for RGMII[x]_RD[3:0], and RGMII[x]_RCTL – RGMII Mode

NO.	PARAMETER	DESCRIPTION	MODE	MIN	TYP	MAX	UNIT
RGMII5	$t_{su(RD-RXC)}$	Setup time, RD[3:0] valid before RXC high/low	10Mbps	1			ns
			100Mbps	1			ns
			1000Mbps	1			ns
	$t_{su(RX_CTL-RXC)}$	Setup time, RX_CTL valid before RXC high/low	10Mbps	1			ns
			100Mbps	1			ns
			1000Mbps	1			ns
RGMII6	$t_{h(RXC-RD)}$	Hold time, RD[3:0] valid after RXC high/low	10Mbps	1			ns
			100Mbps	1			ns
			1000Mbps	1			ns
	$t_{h(RXC-RX_CTL)}$	Hold time, RX_CTL valid after RXC high/low	10Mbps	1			ns
			100Mbps	1			ns
			1000Mbps	1			ns

NO.	PARAMETER	DESCRIPTION	MODE	MIN	TYP	MAX	UNIT
RGMII7	$t_{(RD)}$	Transition time, RD	10Mbps			0.75	ns
			100Mbps			0.75	ns
			1000Mbps			0.75	ns
	$t_{(RX_CTL)}$	Transition time, RX_CTL	10Mbps			0.75	ns
			100Mbps			0.75	ns
			1000Mbps			0.75	ns

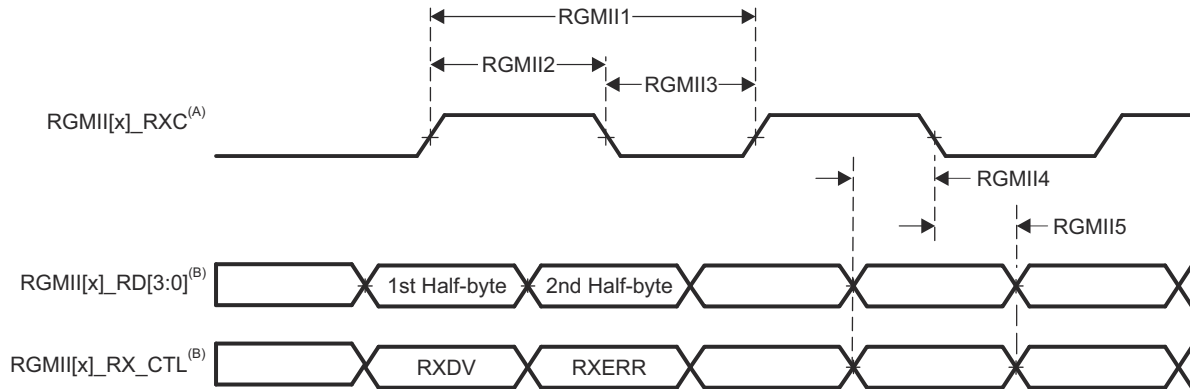

- A. RGMII_RXC must be externally delayed relative to the data and control pins.
- B. Data and control information is received using both edges of the clocks. RGMII_RXD[3:0] carries data bits 3-0 on the rising edge of RGMII_RXC and data bits 7-4 on the falling edge of RGMII_RXC. Similarly, RGMII_RXCTL carries RXDV on rising edge of RGMII_RXC and RXERR on falling edge of RGMII_RXC.

Figure 7-42. CPSW2G Receive Interface Timing, RGMII Operation

Section 7.9.5.2.2.3, Section 7.9.5.2.2.4, and Figure 7-43 present switching characteristics for transmit - RGMII for 10 Mbps, 100 Mbps, and 1000 Mbps.

7.9.5.2.2.3 Switching Characteristics for RGMII[x]_TCLK – RGMII Mode

NO.	PARAMETER	DESCRIPTION	MODE	MIN	TYP	MAX	UNIT
RGMII1	$t_{c(TXC)}$	Cycle time, TXC	10Mbps	360		440	ns
			100Mbps	36		44	ns
			1000Mbps	7.2		8.8	ns
RGMII2	$t_{w(TXCH)}$	Pulse duration, TXC high	10Mbps	160		240	ns
			100Mbps	16		24	ns
			1000Mbps	3.6		4.4	ns
RGMII3	$t_{w(TXCL)}$	Pulse duration, TXC low	10Mbps	160		240	ns
			100Mbps	16		24	ns
			1000Mbps	3.6		4.4	ns
RGMII4	$t_{(TXC)}$	Transition time, TXC	10Mbps			0.75	ns
			100Mbps			0.75	ns
			1000Mbps			0.75	ns

7.9.5.2.2.4 Switching Characteristics for RGMII[x]_TD[3:0], and RGMII[x]_TCTL – RGMII Mode

NO.	PARAMETER	DESCRIPTION	MODE	MIN	TYP	MAX	UNIT
RGMII5	t _{osu} (TD-TXC)	Output setup time, RGMII[x]_TD[3:0] valid to RGMII[x]_TXC high/low	10Mbps	1.2			ns
			100Mbps	1.2		ns	
			1000Mbps	1.05		ns	
	t _{osu} (TX_CTL-TXC)	Output setup time, RGMII[x]_TX_CTL valid to RGMII[x]_TXC high/low	10Mbps	1.2			ns
			100Mbps	1.2		ns	
			1000Mbps	1.05		ns	
RGMII6	t _{oh} (TD-TXC)	Output hold time, RGMII[x]_TD[3:0] valid after RGMII[x]_TXC high/low	10Mbps	1.2			ns
			100Mbps	1.2		ns	
			1000Mbps	1.0		ns	
	t _{oh} (TX_CTL-TXC)	Output hold time, RGMII[x]_TX_CTL valid after RGMII[x]_TXC high/low	10Mbps	1.2			ns
			100Mbps	1.2		ns	
			1000Mbps	1.05		ns	

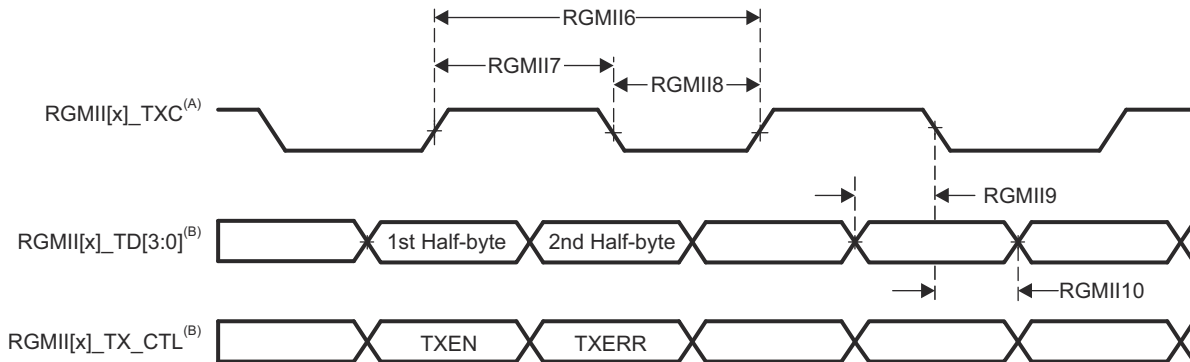

- A. TXC is delayed internally before being driven to the RGMII[x]_TXC pin. This internal delay is always enabled.
- B. Data and control information is received using both edges of the clocks. RGMII_TD[3:0] carries data bits 3-0 on the rising edge of RGMII_TXC and data bits 7-4 on the falling edge of RGMII_TXC. Similarly, RGMII_TX_CTL carries TXDV on rising edge of RGMII_TXC and RTXERR on falling edge of RGMII_TXC.

Figure 7-43. CPSW2G Transmit Interface Timing RGMII Mode

For more information, see *Gigabit Ethernet MAC (MCU_CPSW0)* section in *Peripherals* chapter in the device TRM.

7.9.5.3 CPSW5G

The Gigabit Ethernet MAC supports standards shown in Table 7-28.

Table 7-28. CPSW5G Supported Standards

INDUSTRIAL STANDARDS	BAUD ⁽¹⁾	LINK/ DATA RATE ⁽¹⁾
USXGMII/ XFI	5.15625 GBaud	5 Gbps
	10.3125 GBaud	10 Gbps
QSGMII	5 GBaud	4x 1Gbps
XAUI (2.5G SGMII)	3.125 GBaud	2.5 Gbps
1G SGMII	1.25 GBaud	1 Gbps

(1) Lower data rates are achieved through replication

For more details about features and additional description on the device Gigabit Ethernet MAC, see the corresponding sections within Section 6.3, *Signal Descriptions* and Section 8, *Detailed Description*.

Table 7-29 represents CPSW5G timing conditions.

Table 7-29. CPSW5G Timing Conditions

PARAMETER	DESCRIPTION	MIN	MAX	UNIT
INPUT CONDITIONS				
t_R	Input signal rise time	1	5	V/ns
t_F	Input signal fall time	1	5	V/ns
OUTPUT CONDITIONS				
C_{LOAD}	Output load capacitance	2	20	pF
PCB CONNECTIVITY REQUIREMENTS				
t_d (Trace Mismatch Delay)	Propagation delay mismatch across all traces	RGMII[x]_RXC, RGMII[x]_RD[3:0], RGMII[x]_RX_CTL	50	ps
		RGMII[x]_TXC, RGMII[x]_TD[3:0], RGMII[x]_TX_CTL	50	ps

7.9.5.3.1 CPSW5G MDIO Interface Timings

Table 7-30, Table 7-31, Table 7-32, and Figure 7-44 present timing requirements for MDIO.

Table 7-30. CPSW5G MDIO Timing Conditions

PARAMETER	DESCRIPTION	MIN	MAX	UNIT
INPUT CONDITIONS				
SR_i	Input signal slew rate	0.9	3.6	V/ns
OUTPUT CONDITIONS				
C_L	Output load capacitance	10	470	pF

Table 7-31. Timing Requirements for MDIO Input

NO.	PARAMETER	DESCRIPTION	MIN	MAX	UNIT
MDIO1	$t_{su(MDIO_MDC)}$	Setup time, MDIO_DATA valid before MDIO_CLK high	90		ns
MDIO2	$t_{h(MDIO_MDC)}$	Hold time, MDIO_DATA valid after MDIO_CLK high	0		ns

Table 7-32. Switching Characteristics Over Recommended Operating Conditions for MDIO Output

NO.	PARAMETER	DESCRIPTION	MIN	MAX	UNIT
MDIO3	$t_c(MDC)$	Cycle time, MDIO_CLK	400		ns
MDIO4	$t_w(MDCH)$	Pulse Duration, MDIO_CLK high	160		ns
MDIO5	$t_w(MDCL)$	Pulse Duration, MDIO_CLK low	160		ns
MDIO6	$t_t(MDC)$	Transition time, MDIO_CLK		5	ns
MDIO7	$t_d(MDC_MDIO)$	Delay time, MDIO_CLK High to MDIO_DATA valid	-150	150	ns

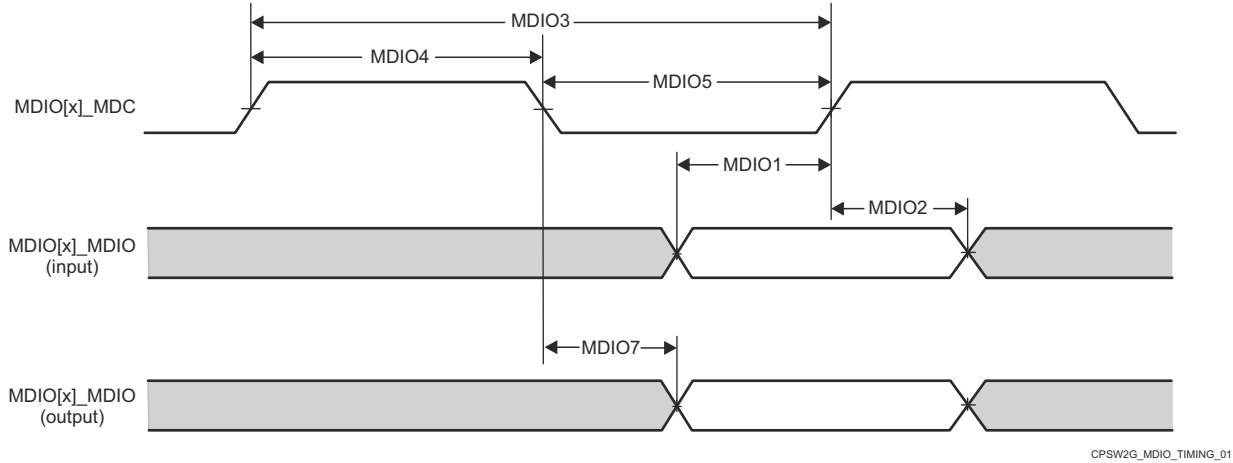

Figure 7-44. CPSW5G MDIO Diagrams Receive and Transmit

7.9.5.3.2 CPSW5G RMIITimings

Section 7.9.5.3.2.1, Section 7.9.5.3.2.2, and Figure 7-45 present timing requirements for CPSW5G RMI receive.

7.9.5.3.2.1 Timing Requirements for RMI[x]_REFCLK – RMI Mode

NO.	PARAMETER	DESCRIPTION	MIN	TYP	MAX	UNIT
RMI1	$t_{c(REF_CLK)}$	Cycle time, REF_CLK	19.999		20.001	ns
RMI2	$t_{w(REF_CLKH)}$	Pulse Duration, REF_CLK High	7		13	ns
RMI3	$t_{w(REF_CLKL)}$	Pulse Duration, REF_CLK Low	7		13	ns

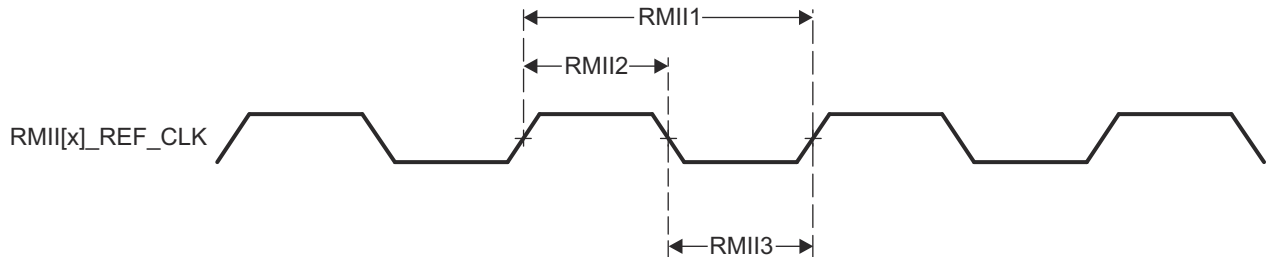

Figure 7-45. RMI[x]_REFCLK Timing – RMI Mode

7.9.5.3.2.2 Timing Requirements for RMI[x]_RXD[1:0], RMI[x]_CRS_DV, and RMI[x]_RXER – RMI Mode

NO.	PARAMETER	DESCRIPTION	MIN	TYP	MAX	UNIT
RMI4	$t_{su(RXD-REF_CLK)}$	Setup time, RXD[1:0] valid before REF_CLK	4			ns
	$t_{su(CRS_DV-REF_CLK)}$	Setup time, CRS_DV valid before REF_CLK	4			ns
	$t_{su(RX_ER-REF_CLK)}$	Setup time, RX_ER valid before REF_CLK	4			ns
RMI5	$t_{h(REF_CLK-RXD)}$	Hold time RXD[1:0] valid after REF_CLK	2			ns
	$t_{h(REF_CLK-CRS_DV)}$	Hold time, CRS_DV valid after REF_CLK	2			ns
	$t_{h(REF_CLK-RX_ER)}$	Hold time, RX_ER valid after REF_CLK	2			ns

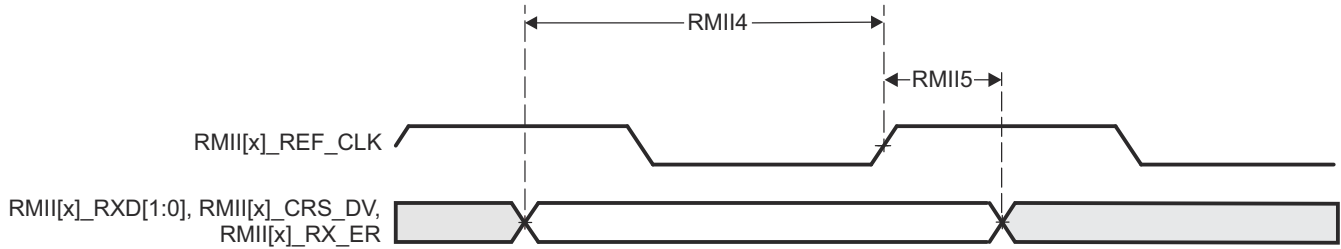

Figure 7-46. RMIIX[x]_RXD[1:0], RMIIX[x]_CRS_DV, RMIIX[x]_RXER Timing – RMIIX Mode

Section 7.9.5.3.2.3, Section 7.9.5.2.1.3, and present switching characteristics for CPSW5G RMIIX transmit.

7.9.5.3.2.3 Switching Characteristics for RMIIX[x]_TXD[1:0], and RMIIX[x]_TXEN – RMIIX Mode

NO.	PARAMETER	DESCRIPTION	MIN	TYP	MAX	UNIT
RMIIX6	$t_{d(REF_CLK-TXD)}$	Delay time, REF_CLK High to TXD[1:0] valid	2		10	ns
	$t_{d(REF_CLK-TXEN)}$	Delay time, REF_CLK to TXEN valid	2		10	ns
RMIIX7	$t_{r(TXD)}$	Rise Time, TXD Outputs	1		5	ns
	$t_{r(TX_EN)}$	Rise Time, TX_EN Output	1		5	ns
RMIIX8	$t_{f(TXD)}$	Fall Time, TXD Outputs	1		5	ns
	$t_{f(TX_EN)}$	Fall Time, TX_EN Output	1		5	ns

7.9.5.3.3 CPSW5G RGMII Timings

Section 7.9.5.3.3.1, Section 7.9.5.3.3.2, and Figure 7-47 present timing requirements for receive RGMII operation.

7.9.5.3.3.1 Timing Requirements for RGMII[x]_RCLK – RGMII Mode

NO.	PARAMETER	DESCRIPTION	MODE	MIN	TYP	MAX	UNIT
RGMII1	$t_{c(RXC)}$	Cycle time, RXC	10Mbps	360		440	ns
			100Mbps	36		44	ns
			1000Mbps	7.2		8.8	ns
RGMII2	$t_{w(RXCH)}$	Pulse duration, RXC high	10Mbps	160		240	ns
			100Mbps	16		24	ns
			1000Mbps	3.6		4.4	ns
RGMII3	$t_{w(RXCL)}$	Pulse duration, RXC low	10Mbps	160		240	ns
			100Mbps	16		24	ns
			1000Mbps	3.6		4.4	ns
RGMII4	$t_{t(RXC)}$	Transition time, RXC	10Mbps			0.75	ns
			100Mbps			0.75	ns
			1000Mbps			0.75	ns

7.9.5.3.3.2 Timing Requirements for RGMII[x]_RD[3:0], and RGMII[x]_RCTL – RGMII Mode

NO.	PARAMETER	DESCRIPTION	MODE	MIN	TYP	MAX	UNIT
RGMII5	$t_{su(RD-RXC)}$	Setup time, RD[3:0] valid before RXC high/low	10Mbps	1			ns
			100Mbps	1			ns
			1000Mbps	1			ns
	$t_{su(RX_CTL-RXC)}$	Setup time, RX_CTL valid before RXC high/low	10Mbps	1			ns
			100Mbps	1			ns
			1000Mbps	1			ns

NO.	PARAMETER	DESCRIPTION	MODE	MIN	TYP	MAX	UNIT
RGMII6	$t_{h(RXC-RD)}$	Hold time, RD[3:0] valid after RXC high/low	10Mbps	1			ns
			100Mbps	1			ns
			1000Mbps	1			ns
	$t_{h(RXC-RX_CTL)}$	Hold time, RX_CTL valid after RXC high/low	10Mbps	1			ns
			100Mbps	1			ns
			1000Mbps	1			ns
RGMII7	$t_{t(RD)}$	Transition time, RD	10Mbps			0.75	ns
			100Mbps			0.75	ns
			1000Mbps			0.75	ns
	$t_{t(RX_CTL)}$	Transition time, RX_CTL	10Mbps			0.75	ns
			100Mbps			0.75	ns
			1000Mbps			0.75	ns

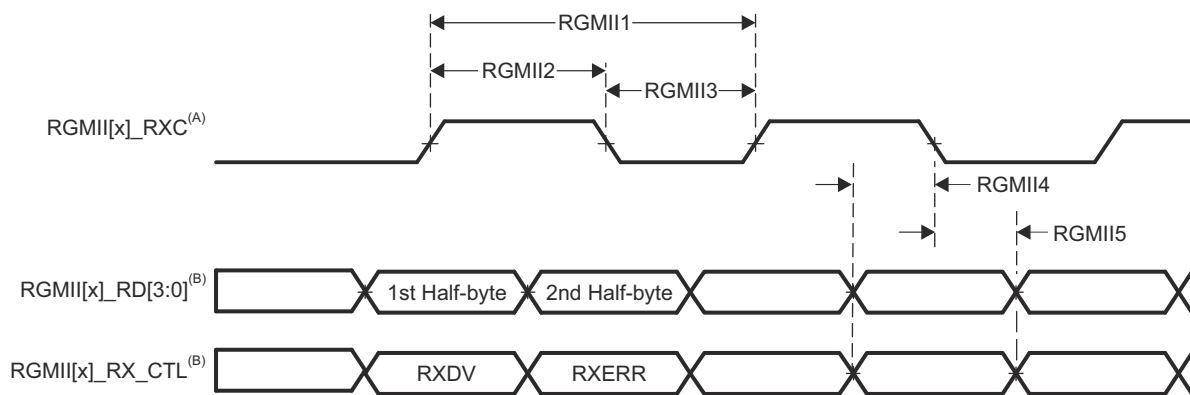

- A. RGMII_RXC must be externally delayed relative to the data and control pins.
 B. Data and control information is received using both edges of the clocks. RGMII_RXD[3:0] carries data bits 3-0 on the rising edge of RGMII_RXC and data bits 7-4 on the falling edge of RGMII_RXC. Similarly, RGMII_RXCTL carries RXDV on rising edge of RGMII_RXC and RXERR on falling edge of RGMII_RXC.

Figure 7-47. CPSW5G Receive Interface Timing, RGMII Operation

Section 7.9.5.3.3.3, Section 7.9.5.3.3.4, and Figure 7-48 present switching characteristics for transmit - RGMII for 10 Mbps, 100 Mbps, and 1000 Mbps.

7.9.5.3.3.3 Switching Characteristics for RGMII[x]_TCLK – RGMII Mode

NO.	PARAMETER	DESCRIPTION	MODE	MIN	TYP	MAX	UNIT
RGMII1	$t_{c(TXC)}$	Cycle time, TXC	10Mbps	360		440	ns
			100Mbps	36		44	ns
			1000Mbps	7.2		8.8	ns
RGMII2	$t_{w(TXCH)}$	Pulse duration, TXC high	10Mbps	160		240	ns
			100Mbps	16		24	ns
			1000Mbps	3.6		4.4	ns
RGMII3	$t_{w(TXCL)}$	Pulse duration, TXC low	10Mbps	160		240	ns
			100Mbps	16		24	ns
			1000Mbps	3.6		4.4	ns
RGMII4	$t_{t(TXC)}$	Transition time, TXC	10Mbps			0.75	ns
			100Mbps			0.75	ns
			1000Mbps			0.75	ns

7.9.5.3.3.4 Switching Characteristics for RGMII[x]_TD[3:0], and RGMII[x]_TCTL – RGMII Mode

NO.	PARAMETER	DESCRIPTION	MODE	MIN	TYP	MAX	UNIT
RGMII5	t _{osu} (TD-TXC)	Output setup time, RGMII[x]_TD[3:0] valid to RGMII[x]_TXC high/low	10Mbps	1.2			ns
			100Mbps	1.2			ns
			1000Mbps	1.05			ns
	t _{osu} (TX_CTL-TXC)	Output setup time, RGMII[x]_TX_CTL valid to RGMII[x]_TXC high/low	10Mbps	1.2			ns
			100Mbps	1.2			ns
			1000Mbps	1.05			ns
RGMII6	t _{oh} (TD-TXC)	Output hold time, RGMII[x]_TD[3:0] valid after RGMII[x]_TXC high/low	10Mbps	1.2			ns
			100Mbps	1.2			ns
			1000Mbps	1.05			ns
	t _{oh} (TX_CTL-TXC)	Output hold time, RGMII[x]_TX_CTL valid after RGMII[x]_TXC high/low	10Mbps	1.2			ns
			100Mbps	1.2			ns
			1000Mbps	1.05			ns

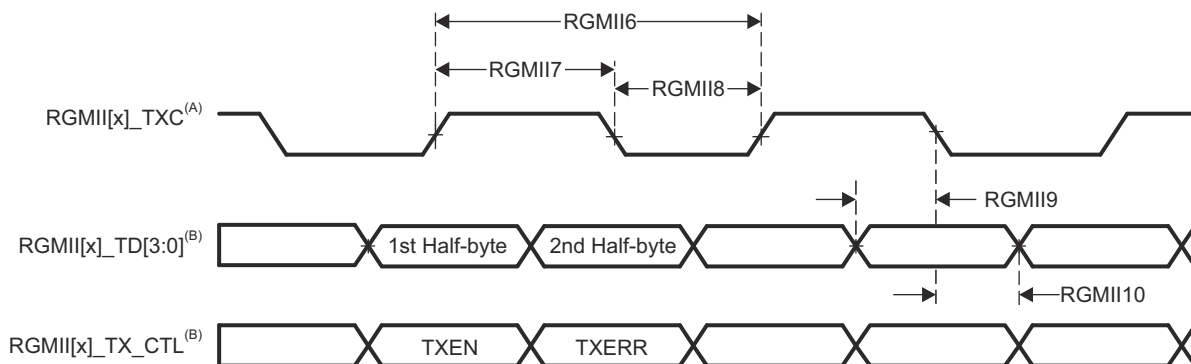

- A. TXC is delayed internally before being driven to the RGMII[x]_TXC pin. This internal delay is always enabled.
- B. Data and control information is received using both edges of the clocks. RGMII_TD[3:0] carries data bits 3-0 on the rising edge of RGMII_TXC and data bits 7-4 on the falling edge of RGMII_TXC. Similarly, RGMII_TX_CTL carries TXDV on rising edge of RGMII_TXC and RTXERR on falling edge of RGMII_TXC.

Figure 7-48. CPSW5G Transmit Interface Timing RGMII Mode

For more information, see *Gigabit Ethernet Switch (CPSW0)* section in *Peripherals* chapter in the device TRM.

7.9.5.4 DDRSS

For more details about features and additional description information on the device LPDDR4 Memory Interfaces, see the corresponding sections within [Section 6.3, Signal Descriptions](#) and [Section 8, Detailed Description](#).

The device has dedicated interface to LPDDR4. It supports JEDEC JESD209-4B standard compliant LPDDR4 SDRAM devices with the following features:

- 32-bit and 16-bit data path to external SDRAM memory
- Memory device capacity: Up to 8GB address space available over two chip selects (4GB per rank)
- No support for byte mode LPDDR4 memories, or memories with more than 17 row address bits

Table 7-33 and Figure 7-49 present switching characteristics for DDRSS.

Table 7-33. Switching Characteristics for DDRSS

NO.	PARAMETER	DESCRIPTION	DDR TYPE	MIN	MAX	UNIT
1	t _c (DDR_CKP/DDR_CKN)	Cycle time, DDR0_CKP and DDR0_CKN	LPDDR4	0.625 ⁽¹⁾	3.003	ns

(1) Maximum DDR Frequency will be limited based on the specific memory type (vendor) used in a system and by PCB implementation. Maximum DDR Frequency will be limited based on the specific memory type (vendor) used in a system and by

PCB implementation. TI strongly recommends all designs to follow the TI LPDDR4 EVM PCB layout exactly in every detail (routing, spacing, vias/backdrill, PCB material, etc.) in order to achieve the full specified clock frequency. Refer to the [Jacinto 7 DDR Board Design and Layout Guidelines](#) for details.

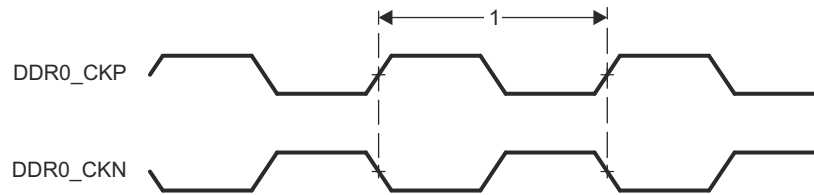

Figure 7-49. DDRSS Memory Interface Clock Timing

For more information, see *DDR Subsystem (DDRSS)* section in *Memory Controllers* chapter in the device TRM.

7.9.5.5 ECAP

The supported features by the device ECAP are:

- 32-bit time base counter
- 4-event time-stamp registers (each 32 bits)
- Independent edge polarity selection for up to four sequenced time-stamp capture events
- Interrupt capabilities on any of the four capture events
- Input capture signal pre-scaling (from 1 to 16)
- Support of different capture modes (single shot capture, continuous mode capture, absolute timestamp capture or difference mode time-stamp capture)

Table 7-34 represents ECAP timing conditions.

Table 7-34. ECAP Timing Conditions

PARAMETER	DESCRIPTION	MIN	MAX	UNIT
Input Conditions				
t_{SR}	Input slew rate	1	4	V/ns
Output Conditions				
C_{LOAD}	Output load capacitance	2	7	pF

Section 7.9.5.5.1 and Section 7.9.5.5.2 present timing and switching characteristics for ECAP (see Figure 7-50 and Figure 7-51).

7.9.5.5.1 Timing Requirements for ECAP

NO.	PARAMETER	DESCRIPTION	MIN	MAX	UNIT
CAP1	$t_{w(CAP)}$	Pulse duration, CAP (asynchronous)	$2 + 2P^{(1)}$		ns

(1) P = sysclk period in ns

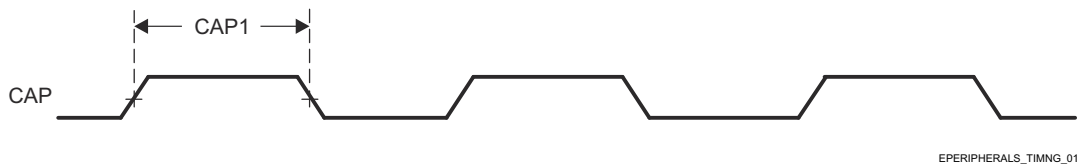

Figure 7-50. ECAP Input Timings

7.9.5.5.2 Switching Characteristics for ECAP

NO.	PARAMETER	DESCRIPTION	MIN	MAX	UNIT
CAP2	$t_w(\text{APWM})$	Pulse duration, APWMx high/low	$-2 + 2P^{(1)}$		ns

(1) P = sysclk period in ns



Figure 7-51. ECAP Output Timings

For more information, see *Enhanced Capture (ECAP) Module* section in *Peripherals* chapter in the device TRM.

7.9.5.6 EPWM

The supported features by the device EPWM are:

- Dedicated 16-bit time-base counter with period and frequency control
- Two independent PWM outputs which can be used in different configurations (with single-edge operation, with dual-edge symmetric operation or one independent PWM output with dual-edge asymmetric operation)
- Asynchronous override control of PWM signals during fault conditions
- Programmable phase-control support for lag or lead operation relative to other EPWM modules
- Dead-band generation with independent rising and falling edge delay control
- Programmable trip zone allocation of both latched and un-latched fault conditions
- Events enabling to trigger both CPU interrupts and start of ADC conversions

Table 7-35 represents EPWM timing conditions.

Table 7-35. EPWM Timing Conditions

PARAMETER	DESCRIPTION	MIN	MAX	UNIT
Input Conditions				
t_{SR}	Input slew rate	1	4	V/ns
Output Conditions				
C_{LOAD}	Output load capacitance	2	7	pF

Section 7.9.5.6.1, and Section 7.9.5.6.2 present timing and switching characteristics for EPWM (see Figure 7-52, Figure 7-53, Figure 7-54, and Figure 7-55).

7.9.5.6.1 Timing Requirements for EPWM

NO.	PARAMETER	DESCRIPTION	MIN	MAX	UNIT
PWM1	$t_w(\text{PWM})$	Pulse duration, PWM output high/low	$P - 3^{(1)}$		ns
PWM2	$t_w(\text{SYNCOUT})$	Pulse duration, Sync output	$P - 3^{(1)}$		ns
PWM3	$t_d(\text{TZ-PWM})$	Delay time, trip input active to PWM forced high/low		11	ns
PWM4	$t_d(\text{TZ-PWMZ})$	Delay time, trip input active to PWM Hi-Z		11	ns

NO.	PARAMETER	DESCRIPTION	MIN	MAX	UNIT
PWM5	$t_{w(SOC)}$	Pulse duration, SOC output (asynchronous)	$P - 3^{(1)}$		ns

(1) P = sysclk period in ns

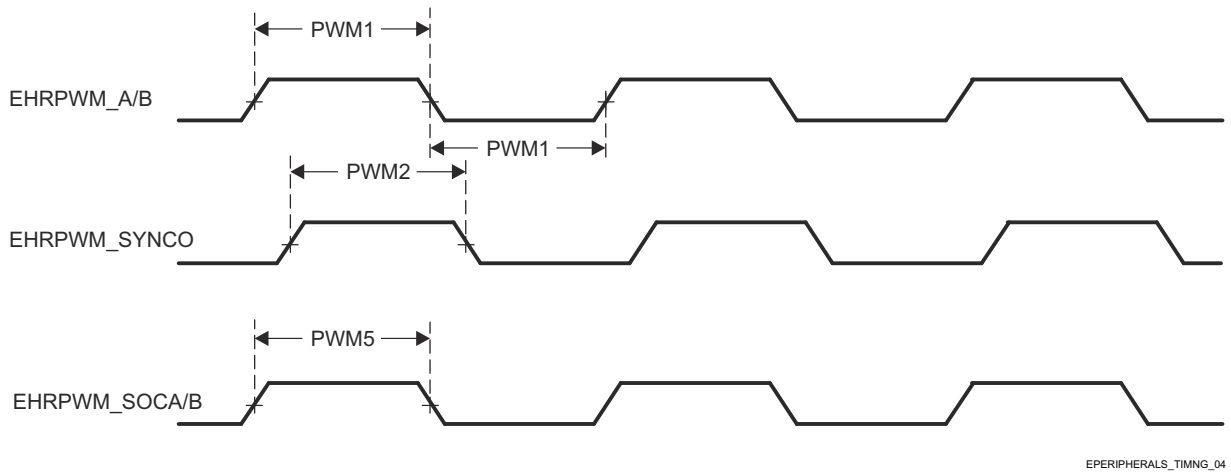

Figure 7-52. EPWM_A/B_out, ePWM_SYNCO, and ePWM_SOCA/B Input Timings

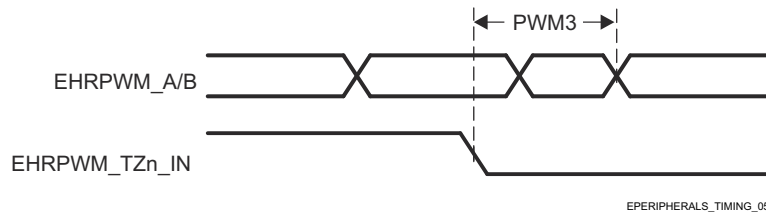

Figure 7-53. EPWM_A/B and ePWM_TZn_IN Forced High/Low Input Timings

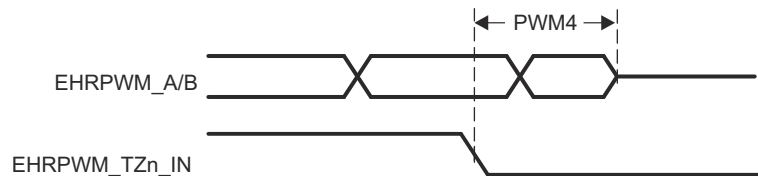

Figure 7-54. EPWM_A/B and ePWM_TZn_IN Hi-Z Input Timings

7.9.5.6.2 Switching Characteristics for EPWM

NO.	PARAMETER	DESCRIPTION	MIN	MAX	UNIT
PWM6	$t_{w(SYNCIN)}$	Pulse duration, Sync input (asynchronous)	$2 + 2P^{(1)}$		ns

NO.	PARAMETER	DESCRIPTION	MIN	MAX	UNIT
PWM7	$t_{w(TZ)}$	Pulse duration, TZx input low (asynchronous)	$2 + 3P^{(1)}$		ns

(1) P = sysclk period in ns

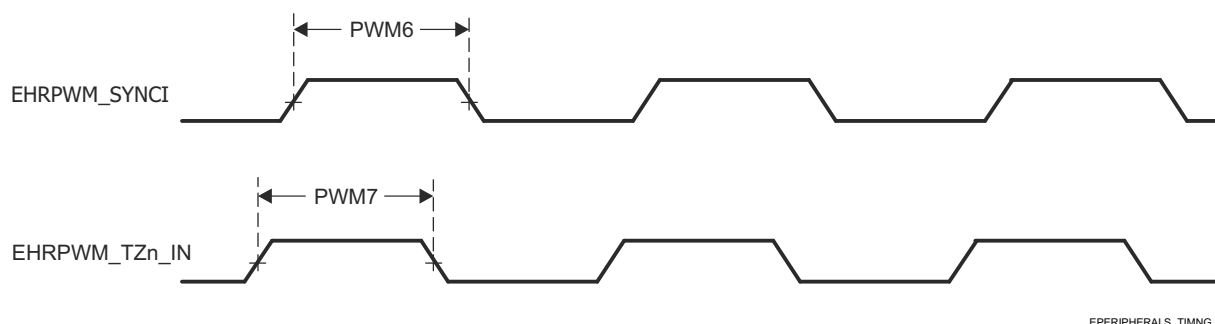

Figure 7-55. ePWM_SYNCI and ePWM_TZn_IN Output Timings

For more information, see *Enhanced Pulse Width Modulation (EPWM) Module* section in *Peripherals* chapter in the device TRM.

7.9.5.7 EQEP

The supported features by the device EQEP are:

- Input Synchronization
- Three Stage/Six Stage Digital Noise Filter
- Quadrature Decoder Unit
- Position Counter and Control unit for position measurement
- Quadrature Edge Capture unit for low speed measurement
- Unit Time base for speed/frequency measurement
- Watchdog Timer for detecting stalls

Table 7-36 represents EQEP timing conditions.

Table 7-36. EQEP Timing Conditions

PARAMETER	DESCRIPTION	MIN	MAX	UNIT
Input Conditions				
SR_i	Input slew rate	1	4	V/ns
Output Conditions				
C_L	Output load capacitance	2	7	pF

Section 7.9.5.7.1 and Section 7.9.5.7.2 present timing requirements and switching characteristics for EQEP (see Figure 7-56).

7.9.5.7.1 Timing Requirements for EQEP

NO.	PARAMETER	DESCRIPTION	MIN	MAX	UNIT
QEP1	$t_{w(QEP)}$	Pulse duration, QEP_A/B	$2 + 2P^{(1)}$		ns
QEP2	$t_{w(QEPIH)}$	Pulse duration, QEP_I high	$2 + 2P^{(1)}$		ns
QEP3	$t_{w(QEPIL)}$	Pulse duration, QEP_I low	$2 + 2P^{(1)}$		ns
QEP4	$t_{w(QEPSH)}$	Pulse duration, QEP_S high	$2 + 2P^{(1)}$		ns

NO.	PARAMETER	DESCRIPTION	MIN	MAX	UNIT
QEP5	$t_{w(QEP_{SL})}$	Pulse duration, QEP_S low	$2 + 2P^{(1)}$		ns

(1) P = sysclk period in ns

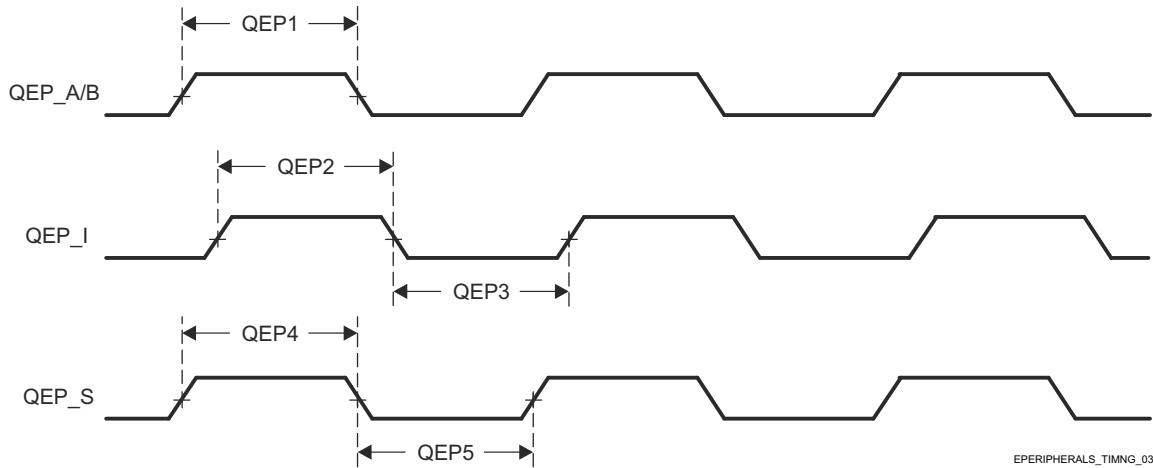

Figure 7-56. EQEP Input Timings

7.9.5.7.2 Switching Characteristics for EQEP

NO.	PARAMETER	DESCRIPTION	MIN	MAX	UNIT
QEP6	$t_{d(QEP-CNTR)}$	Delay time, external clock to counter increment		24	ns

For more information, see *Enhanced Quadrature Encoder Pulse (EQEP) Module* section in *Peripherals* chapter in the device TRM.

7.9.5.8 GPIO

The device has ten instances of GPIO modules. The GPIO modules are integrated in three groups.

- Group one: WKUP_GPIO0 and WKUP_GPIO1
- Group two: GPIO0, GPIO2, GPIO4, and GPIO6
- Group three: GPIO1, GPIO3, GPIO5, and GPIO7

Within each group, exactly one module is selected to control the corresponding I/O pins and pin interrupts.

The GPIO pins are grouped into banks (16 pins per bank), which means that each GPIO module provides up to 144 dedicated general-purpose pins with input and output capabilities; thus, the general-purpose interface supports up to 432 (3 instances × (9 banks × 16 pins)) pins. Since WKUP_GPIOu_[84:143] (u = 0, 1), GPIO_n_[128:143] (n = 0, 2, 4, 6), and GPIO_m_[36:143] (m = 1, 3, 5, 7) are reserved in this device, general purpose interface supports up to 248 I/O pins.

For more details about features and additional description information on the device General-Purpose Interface, see the corresponding sections within [Section 6.3, Signal Descriptions](#) and [Section 8, Detailed Description](#).

Note

The general-purpose input/output *i* (*i* = 0 to 1) is also referred to as GPIO_{*i*}.

[Table 7-37](#), [Table 7-38](#), and [Table 7-39](#) present timing conditions, requirements, and switching characteristics for GPIO.

Table 7-37. GPIO Timing Conditions

PARAMETER	BUFFER TYPE	MIN	MAX	UNIT
INPUT CONDITIONS				

Table 7-37. GPIO Timing Conditions (continued)

PARAMETER		BUFFER TYPE	MIN	MAX	UNIT
SR _I	Input slew rate	LVC MOS	0.2	6.6	V/ns
		I2C OD FS	0.2	0.8	V/ns
OUTPUT CONDITIONS					
C _L	Output load capacitance	LVC MOS	3	10	pF
		I2C OD FS	3	100	pF

Table 7-38. GPIO Timing Requirements

NO.	PARAMETER	DESCRIPTION	MODE	MIN	MAX	UNIT
GPIO1	t _w (GPIO_IN)	Pulse width, GPIO _n _x	1.8 V	2P + 2.6 ⁽¹⁾		ns
			3.3 V	2P + 3.4 ⁽¹⁾		ns

(1) P = functional clock period in ns.

Table 7-39. GPIO Switching Characteristics

NO.	PARAMETER	DESCRIPTION	BUFFER TYPE	MIN	MAX	UNIT
GP3	t _w (GPIO_OUT)	Minimum Output Pulse Width	LVC MOS	-3.6 + 0.975P ⁽¹⁾		ns
GP4	t _w (GPIO_OUT)	Minimum Output Pulse Width Low	I2C Open Drain	160		ns
GP5	t _w (GPIO_OUT)	Minimum Output Pulse Width High	I2C Open Drain	60		ns

(1) P = functional clock period in ns.

For more information, see *General-Purpose Interface (GPIO)* section in *Peripherals* chapter in the device TRM.

7.9.5.9 GPMC

For more details about features and additional description information on the device General-Purpose Memory Controller, see the corresponding sections within [Section 6.3, Signal Descriptions](#) and [Section 8, Detailed Description](#).

Table 7-40. GPMC Timing Conditions

PARAMETER	DESCRIPTION		MIN	MAX	UNIT
Input Conditions					
SR _I	Input slew rate		1.65	4	V/ns
Output Conditions					
C _L	Output load capacitance		5	20	pF
PCB Connectivity Requirements					
t _d (Trace Delay)	Propagation delay of each trace	133 MHz Synchronous Mode	140	360	ps
		All other modes	140	720	
t _d (Trace Mismatch Delay)	Propagation mismatch across all traces			200	ps

7.9.5.9.1 GPMC and NOR Flash — Synchronous Mode

[Section 7.9.5.9.1.1](#) and [Section 7.9.5.9.1.2](#) assume testing over the recommended operating conditions and electrical characteristic conditions below (see [Figure 7-57](#) through [Figure 7-61](#)).

7.9.5.9.1.1 GPMC and NOR Flash Timing Requirements — Synchronous Mode

NO.	PARAMETER	DESCRIPTION	MODE ⁽²⁾	MIN	MAX	MIN	MAX	UNIT
				100 MHz		133 MHz		
F12	t _{su(dV-clkH)}	Setup time, input data GPMC_AD[15:0] valid before output clock GPMC_CLK high	div_by_1_mode; GPMC_FCLK_MUX; TIMEPARAGRANULARITY_X1	1.81		1.11		ns
			not_div_by_1_mode; GPMC_FCLK_MUX; TIMEPARAGRANULARITY_X1	1.06				ns
F13	t _{h(clkH-dV)}	Hold time, input data GPMC_AD[15:0] valid after output clock GPMC_CLK high	div_by_1_mode; GPMC_FCLK_MUX; TIMEPARAGRANULARITY_X1	1.78		2.28		ns
			not_div_by_1_mode; GPMC_FCLK_MUX; TIMEPARAGRANULARITY_X1	1.78				ns
F21	t _{su(waitV-clkH)}	Setup time, input wait GPMC_WAIT[j] valid before output clock GPMC_CLK high ⁽¹⁾	div_by_1_mode; GPMC_FCLK_MUX; TIMEPARAGRANULARITY_X1	1.81		1.11		ns
			not_div_by_1_mode; GPMC_FCLK_MUX; TIMEPARAGRANULARITY_X1	1.06				ns
F22	t _{h(clkH-waitV)}	Hold time, input wait GPMC_WAIT[j] valid after output clock GPMC_CLK high ⁽¹⁾	div_by_1_mode; GPMC_FCLK_MUX; TIMEPARAGRANULARITY_X1	1.78		2.28		ns
			not_div_by_1_mode; GPMC_FCLK_MUX; TIMEPARAGRANULARITY_X1	1.78				ns

(1) In GPMC_WAIT[j], j is equal to 0 or 1.

(2) For div_by_1_mode:

- GPMC_CONFIG1_i Register: GPMCFCLKDIVIDER = 0h:
 - GPMC_CLK frequency = GPMC_FCLK frequency

For not_div_by_1_mode:

- GPMC_CONFIG1_i Register: GPMCFCLKDIVIDER = 1h to 3h:
 - GPMC_CLK frequency = GPMC_FCLK frequency / (2 to 4)

For GPMC_FCLK_MUX:

- CTRLMMR_GPMC_CLKSEL[1-0] CLK_SEL = 01 = PER1_PLL_CLKOUT / 3 = 300 / 3 = 100MHz

For TIMEPARAGRANULARITY_X1:

- GPMC_CONFIG1_i Register: TIMEPARAGRANULARITY = 0h = x1 latencies (affecting RD/WRCYCLETIME, RD/WRACCESSTIME, PAGEBURSTACCESSTIME, CSONTIME, CSRD/WROFFTIME, ADVONTIME, ADVRD/WROFFTIME, OEONTIME, OEOFFTIME, WEONTIME, WEOFFTIME, CYCLE2CYCLEDELAY, BUSTURNAROUND, TIMEOUTSTARTVALUE, WRDATAONADMUXBUS)

7.9.5.9.1.2 GPMC and NOR Flash Switching Characteristics – Synchronous Mode

NO. (2)	PARAMETER	DESCRIPTION	MODE ⁽¹⁹⁾	MIN	MAX	MIN	MAX	UNIT
				100 MHz		133 MHz		
F0	1 / tc(clk)	Period, output clock GPMC_CLK ⁽¹⁸⁾	div_by_1_mode; GPMC_FCLK_MUX; TIMEPARAGRANULARITY_X1	10		7.52		ns
F1	t _{w(clkH)}	Typical pulse duration, output clock GPMC_CLK high	div_by_1_mode; GPMC_FCLK_MUX; TIMEPARAGRANULARITY_X1	-0.3+ 0.475* p ⁽¹⁵⁾		-0.3+ 0.475* p ⁽¹⁵⁾		ns
F1	t _{w(clkL)}	Typical pulse duration, output clock GPMC_CLK low	div_by_1_mode; GPMC_FCLK_MUX; TIMEPARAGRANULARITY_X1	-0.3+ 0.475* p ⁽¹⁵⁾		-0.3+ 0.475* p ⁽¹⁵⁾		ns

NO. (2)	PARAMETER	DESCRIPTION	MODE ⁽¹⁹⁾	MIN	MAX	MIN	MAX	UNIT
				100 MHz		133 MHz		
F2	$t_{d(\text{clkH-csnV})}$	Delay time, output clock GPMC_CLK rising edge to output chip select GPMC_CS[n][i] transition ⁽¹⁴⁾	div_by_1_mode; GPMC_FCLK_MUX; TIMEPARAGRANULARITY_X1; no extra_delay	-2.2+F (6)	3.75+F (6)	-2.2+F (6)	3.75+F (6)	ns
F3	$t_{d(\text{clkH-CSn[i]V})}$	Delay time, output clock GPMC_CLK rising edge to output chip select GPMC_CS[n][i] invalid ⁽¹⁴⁾	div_by_1_mode; GPMC_FCLK_MUX; TIMEPARAGRANULARITY_X1; no extra_delay	-2.2+E (5)	3.75+E (5)	-2.2+E (5)	3.75+E (5)	ns
F4	$t_{d(\text{aV-clk})}$	Delay time, output address GPMC_A[27:1] valid to output clock GPMC_CLK first edge	div_by_1_mode; GPMC_FCLK_MUX; TIMEPARAGRANULARITY_X1	-2.3+B (2)	4.5+B (2)	-2.3+B (2)	4.5+B (2)	ns
F5	$t_{d(\text{clkH-aIV})}$	Delay time, output clock GPMC_CLK rising edge to output address GPMC_A[27:1] invalid	div_by_1_mode; GPMC_FCLK_MUX; TIMEPARAGRANULARITY_X1	-2.3	4.5	-2.3	4.5	ns
F6	$t_{d(\text{be[x]nV-clk})}$	Delay time, output lower byte enable and command latch enable GPMC_BE0n_CLE, output upper byte enable GPMC_BE1n valid to output clock GPMC_CLK first edge	div_by_1_mode; GPMC_FCLK_MUX; TIMEPARAGRANULARITY_X1	-2.3+B (2)	1.9+B (2)	-2.3+B (2)	1.9+B (2)	ns
F7	$t_{d(\text{clkH-be[x]nIV})}$	Delay time, output clock GPMC_CLK rising edge to output lower byte enable and command latch enable GPMC_BE0n_CLE, output upper byte enable GPMC_BE1n invalid ⁽¹¹⁾	div_by_1_mode; GPMC_FCLK_MUX; TIMEPARAGRANULARITY_X1	-2.3+D (4)	1.9+D (4)	-2.3+D (4)	1.9+D (4)	ns
F7	$t_{d(\text{clkL-be[x]nIV})}$	Delay time, GPMC_CLK falling edge to GPMC_BE0n_CLE, GPMC_BE1n invalid ⁽¹²⁾	div_by_1_mode; GPMC_FCLK_MUX; TIMEPARAGRANULARITY_X1	-2.3+D (4)	1.9+D (4)	-2.3+D (4)	1.9+D (4)	ns
F7	$t_{d(\text{clkL-be[x]nIV})}$	Delay time, GPMC_CLK falling edge to GPMC_BE0n_CLE, GPMC_BE1n invalid ⁽¹³⁾	div_by_1_mode; GPMC_FCLK_MUX; TIMEPARAGRANULARITY_X1	-2.3+D (4)	1.9+D (4)	-2.3+D (4)	1.9+D (4)	ns
F8	$t_{d(\text{clkH-advn})}$	Delay time, output clock GPMC_CLK rising edge to output address valid and address latch enable GPMC_ADVn_ALE transition	div_by_1_mode; GPMC_FCLK_MUX; TIMEPARAGRANULARITY_X1; no extra_delay	-2.3+G (7)	4.5+G (7)	-2.3+G (7)	4.5+G (7)	ns
F9	$t_{d(\text{clkH-advnIV})}$	Delay time, output clock GPMC_CLK rising edge to output address valid and address latch enable GPMC_ADVn_ALE invalid	div_by_1_mode; GPMC_FCLK_MUX; TIMEPARAGRANULARITY_X1; no extra_delay	-2.3+D (4)	4.5+D (4)	-2.3+D (4)	4.5+D (4)	ns
F10	$t_{d(\text{clkH-oen})}$	Delay time, output clock GPMC_CLK rising edge to output enable GPMC_OEn_REn transition	div_by_1_mode; GPMC_FCLK_MUX; TIMEPARAGRANULARITY_X1; no extra_delay	-2.3H ⁽⁸⁾	3.5+H (8)	-2.3H ⁽⁸⁾	3.5+H (8)	ns
F11	$t_{d(\text{clkH-oenIV})}$	Delay time, output clock GPMC_CLK rising edge to output enable GPMC_OEn_REn invalid	div_by_1_mode; GPMC_FCLK_MUX; TIMEPARAGRANULARITY_X1; no extra_delay	-2.3+E (8)	3.5+E (8)	-2.3+E (8)	3.5+E (8)	ns
F14	$t_{d(\text{clkH-wen})}$	Delay time, output clock GPMC_CLK rising edge to output write enable GPMC_WEn transition	div_by_1_mode; GPMC_FCLK_MUX; TIMEPARAGRANULARITY_X1; no extra_delay	-2.3+I ⁽⁹⁾	4.5+I ⁽⁹⁾	-2.3+I (9)	4.5+I ⁽⁹⁾	ns
F15	$t_{d(\text{clkH-do})}$	Delay time, output clock GPMC_CLK rising edge to output data GPMC_AD[15:0] transition ⁽¹¹⁾	div_by_1_mode; GPMC_FCLK_MUX; TIMEPARAGRANULARITY_X1	-2.3+J (10)	2.7+J (10)	-2.3+J (10)	2.7+J (10)	ns
F15	$t_{d(\text{clkL-do})}$	Delay time, GPMC_CLK falling edge to GPMC_AD[15:0] data bus transition ⁽¹²⁾	div_by_1_mode; GPMC_FCLK_MUX; TIMEPARAGRANULARITY_X1	-2.3+J (10)	2.7+J (10)	-2.3+J (10)	2.7+J (10)	ns
F15	$t_{d(\text{clkL-do})}$	Delay time, GPMC_CLK falling edge to GPMC_AD[15:0] data bus transition ⁽¹³⁾	div_by_1_mode; GPMC_FCLK_MUX; TIMEPARAGRANULARITY_X1	-2.3+J (10)	2.7+J (10)	-2.3+J (10)	2.7+J (10)	ns

NO. (2)	PARAMETER	DESCRIPTION	MODE ⁽¹⁹⁾	MIN	MAX	MIN	MAX	UNIT
				100 MHz	133 MHz	133 MHz	100 MHz	
F17	$t_{d(\text{clkH-be}[x]n)}$	Delay time, output clock GPMC_CLK rising edge to output lower byte enable and command latch enable GPMC_BE0n_CLE transition ⁽¹¹⁾	div_by_1_mode; GPMC_FCLK_MUX; TIMEPARAGRANULARITY_X1	-2.3+J (10)	1.9+J (10)	-2.3+J (10)	1.9+J (10)	ns
F17	$t_{d(\text{clkL-be}[x]n)}$	Delay time, GPMC_CLK falling edge to GPMC_BE0n_CLE, GPMC_BE1n transition ⁽¹²⁾	div_by_1_mode; GPMC_FCLK_MUX; TIMEPARAGRANULARITY_X1	-2.3+J (10)	1.9+J (10)	-2.3+J (10)	1.9+J (10)	ns
F17	$t_{d(\text{clkL-be}[x]n)}$	Delay time, GPMC_CLK falling edge to GPMC_BE0n_CLE, GPMC_BE1n transition ⁽¹³⁾	div_by_1_mode; GPMC_FCLK_MUX; TIMEPARAGRANULARITY_X1	-2.3+J (10)	1.9+J (10)	-2.3+J (10)	1.9+J (10)	ns
F18	$t_{w(\text{csnV})}$	Pulse duration, output chip select GPMC_CS[n] low ⁽¹⁴⁾	Read	A ⁽¹⁾		A ⁽¹⁾		ns
			Write	A ⁽¹⁾		A ⁽¹⁾		ns
F19	$t_{w(\text{be}[x]nV)}$	Pulse duration, output lower byte enable and command latch enable GPMC_BE0n_CLE, output upper byte enable GPMC_BE1n low	Read	C ⁽³⁾		C ⁽³⁾		ns
			Write	C ⁽³⁾		C ⁽³⁾		ns
F20	$t_{w(\text{advnV})}$	Pulse duration, output address valid and address latch enable GPMC_ADVn_ALE low	Read	K ⁽¹⁶⁾		K ⁽¹⁶⁾		ns
			Write	K ⁽¹⁶⁾		K ⁽¹⁶⁾		ns

- (1) For single read: $A = (\text{CSRdOffTime} - \text{CSOnTime}) \times (\text{TimeParaGranularity} + 1) \times \text{GPMC_FCLK}^{(17)}$
 For burst read: $A = (\text{CSRdOffTime} - \text{CSOnTime} + (n - 1) \times \text{PageBurstAccessTime}) \times (\text{TimeParaGranularity} + 1) \times \text{GPMC_FCLK}^{(17)}$
 For burst write: $A = (\text{CSWrOffTime} - \text{CSOnTime} + (n - 1) \times \text{PageBurstAccessTime}) \times (\text{TimeParaGranularity} + 1) \times \text{GPMC_FCLK}^{(17)}$
 With n being the page burst access number.
- (2) $B = \text{ClkActivationTime} \times \text{GPMC_FCLK}^{(17)}$
- (3) For single read: $C = \text{RdCycleTime} \times (\text{TimeParaGranularity} + 1) \times \text{GPMC_FCLK}^{(17)}$
 For burst read: $C = (\text{RdCycleTime} + (n - 1) \times \text{PageBurstAccessTime}) \times (\text{TimeParaGranularity} + 1) \times \text{GPMC_FCLK}^{(17)}$
 For burst write: $C = (\text{WrCycleTime} + (n - 1) \times \text{PageBurstAccessTime}) \times (\text{TimeParaGranularity} + 1) \times \text{GPMC_FCLK}^{(17)}$
 With n being the page burst access number.
- (4) For single read: $D = (\text{RdCycleTime} - \text{AccessTime}) \times (\text{TimeParaGranularity} + 1) \times \text{GPMC_FCLK}^{(17)}$
 For burst read: $D = (\text{RdCycleTime} - \text{AccessTime}) \times (\text{TimeParaGranularity} + 1) \times \text{GPMC_FCLK}^{(17)}$
 For burst write: $D = (\text{WrCycleTime} - \text{AccessTime}) \times (\text{TimeParaGranularity} + 1) \times \text{GPMC_FCLK}^{(17)}$
- (5) For single read: $E = (\text{CSRdOffTime} - \text{AccessTime}) \times (\text{TimeParaGranularity} + 1) \times \text{GPMC_FCLK}^{(17)}$
 For burst read: $E = (\text{CSRdOffTime} - \text{AccessTime}) \times (\text{TimeParaGranularity} + 1) \times \text{GPMC_FCLK}^{(17)}$
 For burst write: $E = (\text{CSWrOffTime} - \text{AccessTime}) \times (\text{TimeParaGranularity} + 1) \times \text{GPMC_FCLK}^{(17)}$
- (6) For csn falling edge (CS activated):
- Case GPMCFCLKDIVIDER = 0:
 - $F = 0.5 \times \text{CSExtraDelay} \times \text{GPMC_FCLK}^{(17)}$
 - Case GPMCFCLKDIVIDER = 1:
 - $F = 0.5 \times \text{CSExtraDelay} \times \text{GPMC_FCLK}^{(17)}$ if (ClkActivationTime and CSOnTime are odd) or (ClkActivationTime and CSOnTime are even)
 - $F = (1 + 0.5 \times \text{CSExtraDelay}) \times \text{GPMC_FCLK}^{(17)}$ otherwise
 - Case GPMCFCLKDIVIDER = 2:
 - $F = 0.5 \times \text{CSExtraDelay} \times \text{GPMC_FCLK}^{(17)}$ if ((CSOnTime - ClkActivationTime) is a multiple of 3)
 - $F = (1 + 0.5 \times \text{CSExtraDelay}) \times \text{GPMC_FCLK}^{(17)}$ if ((CSOnTime - ClkActivationTime - 1) is a multiple of 3)
 - $F = (2 + 0.5 \times \text{CSExtraDelay}) \times \text{GPMC_FCLK}^{(17)}$ if ((CSOnTime - ClkActivationTime - 2) is a multiple of 3)
- (7) For ADV falling edge (ADV activated):
- Case GPMCFCLKDIVIDER = 0:
 - $G = 0.5 \times \text{ADVExtraDelay} \times \text{GPMC_FCLK}^{(17)}$
 - Case GPMCFCLKDIVIDER = 1:
 - $G = 0.5 \times \text{ADVExtraDelay} \times \text{GPMC_FCLK}^{(17)}$ if (ClkActivationTime and ADVOnTime are odd) or (ClkActivationTime and ADVOnTime are even)
 - $G = (1 + 0.5 \times \text{ADVExtraDelay}) \times \text{GPMC_FCLK}^{(17)}$ otherwise
 - Case GPMCFCLKDIVIDER = 2:
 - $G = 0.5 \times \text{ADVExtraDelay} \times \text{GPMC_FCLK}^{(17)}$ if ((ADVOnTime - ClkActivationTime) is a multiple of 3)
 - $G = (1 + 0.5 \times \text{ADVExtraDelay}) \times \text{GPMC_FCLK}^{(17)}$ if ((ADVOnTime - ClkActivationTime - 1) is a multiple of 3)
 - $G = (2 + 0.5 \times \text{ADVExtraDelay}) \times \text{GPMC_FCLK}^{(17)}$ if ((ADVOnTime - ClkActivationTime - 2) is a multiple of 3)

For ADV rising edge (ADV deactivated) in Reading mode:

- Case GPMCFCLKDIVIDER = 0:
 - $G = 0.5 \times \text{ADVExtraDelay} \times \text{GPMC_FCLK}^{(17)}$
- Case GPMCFCLKDIVIDER = 1:
 - $G = 0.5 \times \text{ADVExtraDelay} \times \text{GPMC_FCLK}^{(17)}$ if (ClkActivationTime and ADVRdOffTime are odd) or (ClkActivationTime and ADVRdOffTime are even)
 - $G = (1 + 0.5 \times \text{ADVExtraDelay}) \times \text{GPMC_FCLK}^{(17)}$ otherwise
- Case GPMCFCLKDIVIDER = 2:
 - $G = 0.5 \times \text{ADVExtraDelay} \times \text{GPMC_FCLK}^{(17)}$ if ((ADVRdOffTime - ClkActivationTime) is a multiple of 3)
 - $G = (1 + 0.5 \times \text{ADVExtraDelay}) \times \text{GPMC_FCLK}^{(17)}$ if ((ADVRdOffTime - ClkActivationTime - 1) is a multiple of 3)
 - $G = (2 + 0.5 \times \text{ADVExtraDelay}) \times \text{GPMC_FCLK}^{(17)}$ if ((ADVRdOffTime - ClkActivationTime - 2) is a multiple of 3)

For ADV rising edge (ADV deactivated) in Writing mode:

- Case GPMCFCLKDIVIDER = 0:
 - $G = 0.5 \times \text{ADVExtraDelay} \times \text{GPMC_FCLK}^{(17)}$
- Case GPMCFCLKDIVIDER = 1:
 - $G = 0.5 \times \text{ADVExtraDelay} \times \text{GPMC_FCLK}^{(17)}$ if (ClkActivationTime and ADVWrOffTime are odd) or (ClkActivationTime and ADVWrOffTime are even)
 - $G = (1 + 0.5 \times \text{ADVExtraDelay}) \times \text{GPMC_FCLK}^{(17)}$ otherwise
- Case GPMCFCLKDIVIDER = 2:
 - $G = 0.5 \times \text{ADVExtraDelay} \times \text{GPMC_FCLK}^{(17)}$ if ((ADVWrOffTime - ClkActivationTime) is a multiple of 3)
 - $G = (1 + 0.5 \times \text{ADVExtraDelay}) \times \text{GPMC_FCLK}^{(17)}$ if ((ADVWrOffTime - ClkActivationTime - 1) is a multiple of 3)
 - $G = (2 + 0.5 \times \text{ADVExtraDelay}) \times \text{GPMC_FCLK}^{(17)}$ if ((ADVWrOffTime - ClkActivationTime - 2) is a multiple of 3)

(8) For OE falling edge (OE activated) and IO DIR rising edge (Data Bus input direction):

- Case GPMCFCLKDIVIDER = 0:
 - $H = 0.5 \times \text{OEEExtraDelay} \times \text{GPMC_FCLK}^{(17)}$
- Case GPMCFCLKDIVIDER = 1:
 - $H = 0.5 \times \text{OEEExtraDelay} \times \text{GPMC_FCLK}^{(17)}$ if (ClkActivationTime and OEOnTime are odd) or (ClkActivationTime and OEOnTime are even)
 - $H = (1 + 0.5 \times \text{OEEExtraDelay}) \times \text{GPMC_FCLK}^{(17)}$ otherwise
- Case GPMCFCLKDIVIDER = 2:
 - $H = 0.5 \times \text{OEEExtraDelay} \times \text{GPMC_FCLK}^{(17)}$ if ((OEOnTime - ClkActivationTime) is a multiple of 3)
 - $H = (1 + 0.5 \times \text{OEEExtraDelay}) \times \text{GPMC_FCLK}^{(17)}$ if ((OEOnTime - ClkActivationTime - 1) is a multiple of 3)
 - $H = (2 + 0.5 \times \text{OEEExtraDelay}) \times \text{GPMC_FCLK}^{(17)}$ if ((OEOnTime - ClkActivationTime - 2) is a multiple of 3)

For OE rising edge (OE deactivated):

- Case GPMCFCLKDIVIDER = 0:
 - $H = 0.5 \times \text{OEEExtraDelay} \times \text{GPMC_FCLK}^{(17)}$
- Case GPMCFCLKDIVIDER = 1:
 - $H = 0.5 \times \text{OEEExtraDelay} \times \text{GPMC_FCLK}^{(17)}$ if (ClkActivationTime and OEOffTime are odd) or (ClkActivationTime and OEOffTime are even)
 - $H = (1 + 0.5 \times \text{OEEExtraDelay}) \times \text{GPMC_FCLK}^{(17)}$ otherwise
- Case GPMCFCLKDIVIDER = 2:
 - $H = 0.5 \times \text{OEEExtraDelay} \times \text{GPMC_FCLK}^{(17)}$ if ((OEOffTime - ClkActivationTime) is a multiple of 3)
 - $H = (1 + 0.5 \times \text{OEEExtraDelay}) \times \text{GPMC_FCLK}^{(17)}$ if ((OEOffTime - ClkActivationTime - 1) is a multiple of 3)
 - $H = (2 + 0.5 \times \text{OEEExtraDelay}) \times \text{GPMC_FCLK}^{(17)}$ if ((OEOffTime - ClkActivationTime - 2) is a multiple of 3)

(9) For WE falling edge (WE activated):

- Case GPMCFCLKDIVIDER = 0:
 - $I = 0.5 \times \text{WEEExtraDelay} \times \text{GPMC_FCLK}^{(17)}$
- Case GPMCFCLKDIVIDER = 1:
 - $I = 0.5 \times \text{WEEExtraDelay} \times \text{GPMC_FCLK}^{(17)}$ if (ClkActivationTime and WEOnTime are odd) or (ClkActivationTime and WEOnTime are even)
 - $I = (1 + 0.5 \times \text{WEEExtraDelay}) \times \text{GPMC_FCLK}^{(17)}$ otherwise
- Case GPMCFCLKDIVIDER = 2:
 - $I = 0.5 \times \text{WEEExtraDelay} \times \text{GPMC_FCLK}^{(17)}$ if ((WEOnTime - ClkActivationTime) is a multiple of 3)

- $I = (1 + 0.5 \times \text{WEEExtraDelay}) \times \text{GPMC_FCLK}^{(17)}$ if $((\text{WEOnTime} - \text{ClkActivationTime} - 1))$ is a multiple of 3
- $I = (2 + 0.5 \times \text{WEEExtraDelay}) \times \text{GPMC_FCLK}^{(17)}$ if $((\text{WEOnTime} - \text{ClkActivationTime} - 2))$ is a multiple of 3

For WE rising edge (WE deactivated):

- Case GPMCFCLKDIVIDER = 0:
 - $I = 0.5 \times \text{WEEExtraDelay} \times \text{GPMC_FCLK}^{(17)}$
- Case GPMCFCLKDIVIDER = 1:
 - $I = 0.5 \times \text{WEEExtraDelay} \times \text{GPMC_FCLK}^{(17)}$ if $(\text{ClkActivationTime}$ and WEOffTime are odd) or $(\text{ClkActivationTime}$ and WEOffTime are even)
 - $I = (1 + 0.5 \times \text{WEEExtraDelay}) \times \text{GPMC_FCLK}^{(17)}$ otherwise
- Case GPMCFCLKDIVIDER = 2:
 - $I = 0.5 \times \text{WEEExtraDelay} \times \text{GPMC_FCLK}^{(17)}$ if $((\text{WEOffTime} - \text{ClkActivationTime}))$ is a multiple of 3
 - $I = (1 + 0.5 \times \text{WEEExtraDelay}) \times \text{GPMC_FCLK}^{(17)}$ if $((\text{WEOffTime} - \text{ClkActivationTime} - 1))$ is a multiple of 3
 - $I = (2 + 0.5 \times \text{WEEExtraDelay}) \times \text{GPMC_FCLK}^{(17)}$ if $((\text{WEOffTime} - \text{ClkActivationTime} - 2))$ is a multiple of 3

(10) $J = \text{GPMC_FCLK}^{(17)}$

(11) First transfer only for CLK DIV 1 mode.

(12) Half cycle; for all data after initial transfer for CLK DIV 1 mode.

(13) Half cycle of GPMC_CLKOUT; for all data for modes other than CLK DIV 1 mode. GPMC_CLKOUT divide down from GPMC_FCLK.

(14) In GPMC_CS*n*[*j*], *i* is equal to 0, 1, 2 or 3. In GPMC_WAIT[*j*], *j* is equal to 0 or 1.

(15) $P = \text{GPMC_CLK}$ period in ns

(16) For read: $K = (\text{ADVrdOffTime} - \text{ADVOnTime}) \times (\text{TimeParaGranularity} + 1) \times \text{GPMC_FCLK}^{(17)}$

For write: $K = (\text{ADVWrOffTime} - \text{ADVOnTime}) \times (\text{TimeParaGranularity} + 1) \times \text{GPMC_FCLK}^{(17)}$

(17) GPMC_FCLK is general-purpose memory controller internal functional clock period in ns.

(18) Related to the GPMC_CLK output clock maximum and minimum frequencies programmable in the GPMC module by setting the GPMC_CONFIG1_1 configuration register bit field GPMCFCLKDIVIDER.

(19) For div_by_1_mode:

- GPMC_CONFIG1_1 register: GPMCFCLKDIVIDER = 0h:
 - GPMC_CLK frequency = GPMC_FCLK frequency

For GPMC_FCLK_MUX:

- CTRLMMR_GPMC_CLKSEL[1-0] CLK_SEL = 01 = PER1_PLL_CLKOUT / 3 = 300 / 3 = 100MHz

For TIMEPARAGRANULARITY_X1:

- GPMC_CONFIG1_1 Register: TIMEPARAGRANULARITY = 0h = x1 latencies (affecting RD/WRCYCLETIME, RD/WRACCESSTIME, PAGEBURSTACCESSTIME, CSONTIME, CSRD/WROFFTIME, ADVONTIME, ADVRD/WROFFTIME, OEONTIME, OEOFFTIME, WEONTIME, WEOFFTIME, CYCLE2CYCLEDELAY, BUSTURNAROUND, TIMEOUTSTARTVALUE, WRDATAONADMUXBUS)

For no extra_delay:

- GPMC_CONFIG2_1 Register: CSEXTRADELAY = 0h = CS*n* Timing control signal is not delayed
- GPMC_CONFIG4_1 Register: WEEXTRADELAY = 0h = nWE timing control signal is not delayed
- GPMC_CONFIG4_1 Register: OEEXTRADELAY = 0h = nOE timing control signal is not delayed
- GPMC_CONFIG3_1 Register: ADVEXTRADELAY = 0h = nADV timing control signal is not delayed

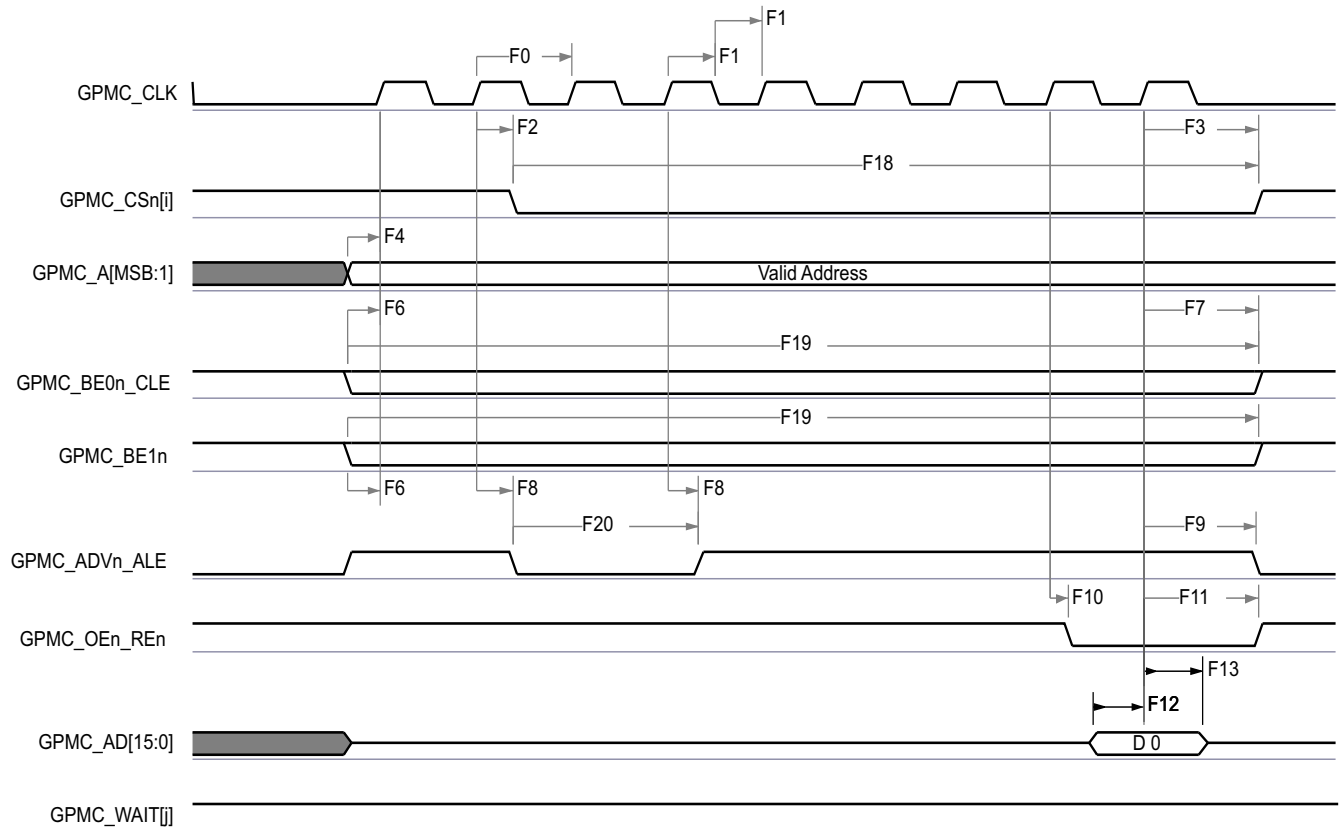

GPMC_01

- A. In GPMC_CSn[i], i is equal to 0, 1, 2 or 3.
- B. In GPMC_WAIT[j], j is equal to 0 or 1.

Figure 7-57. GPMC and NOR Flash — Synchronous Single Read (GPMCFCLKDIVIDER = 0)

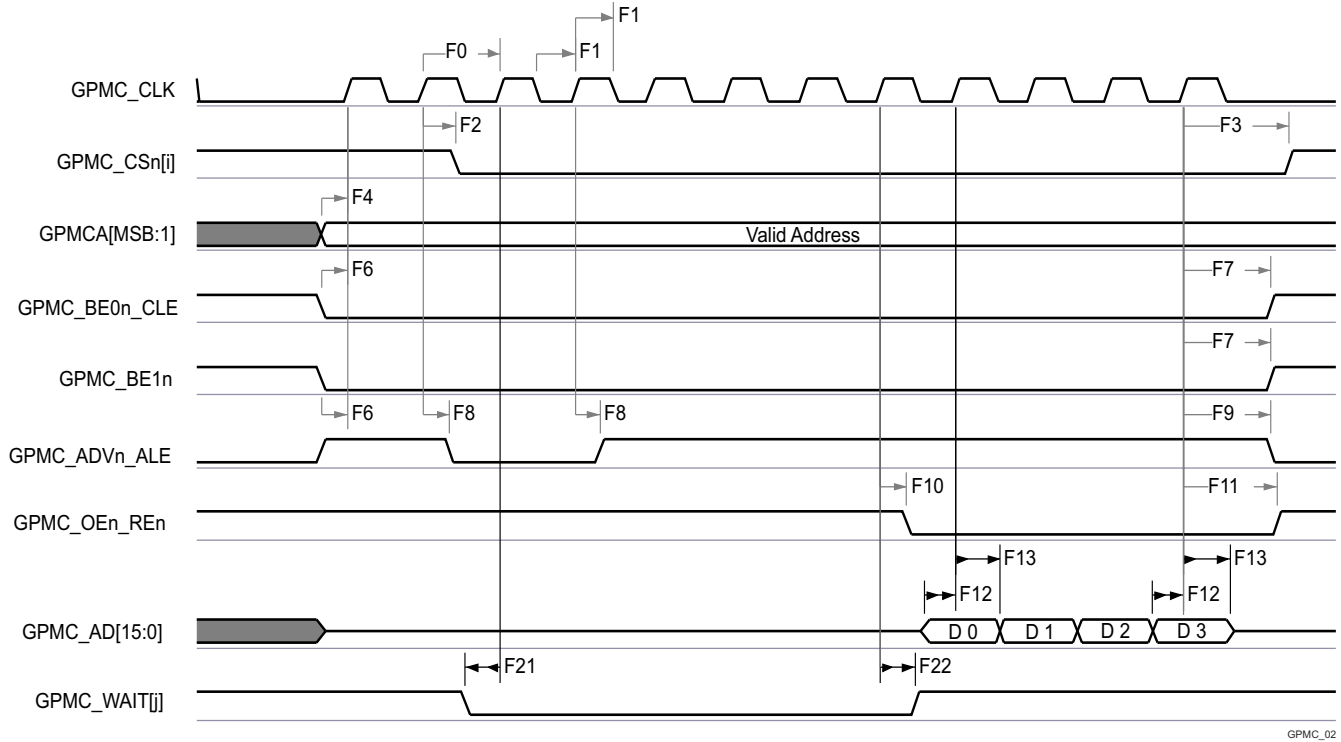

GPMC_02

- A. In GPMC_CS*n*[i], i is equal to 0, 1, 2 or 3.
- B. In GPMC_WAIT[i], j is equal to 0 or 1.

Figure 7-58. GPMC and NOR Flash — Synchronous Burst Read — 4x16-bit (GPMCFCLKDIVIDER = 0)

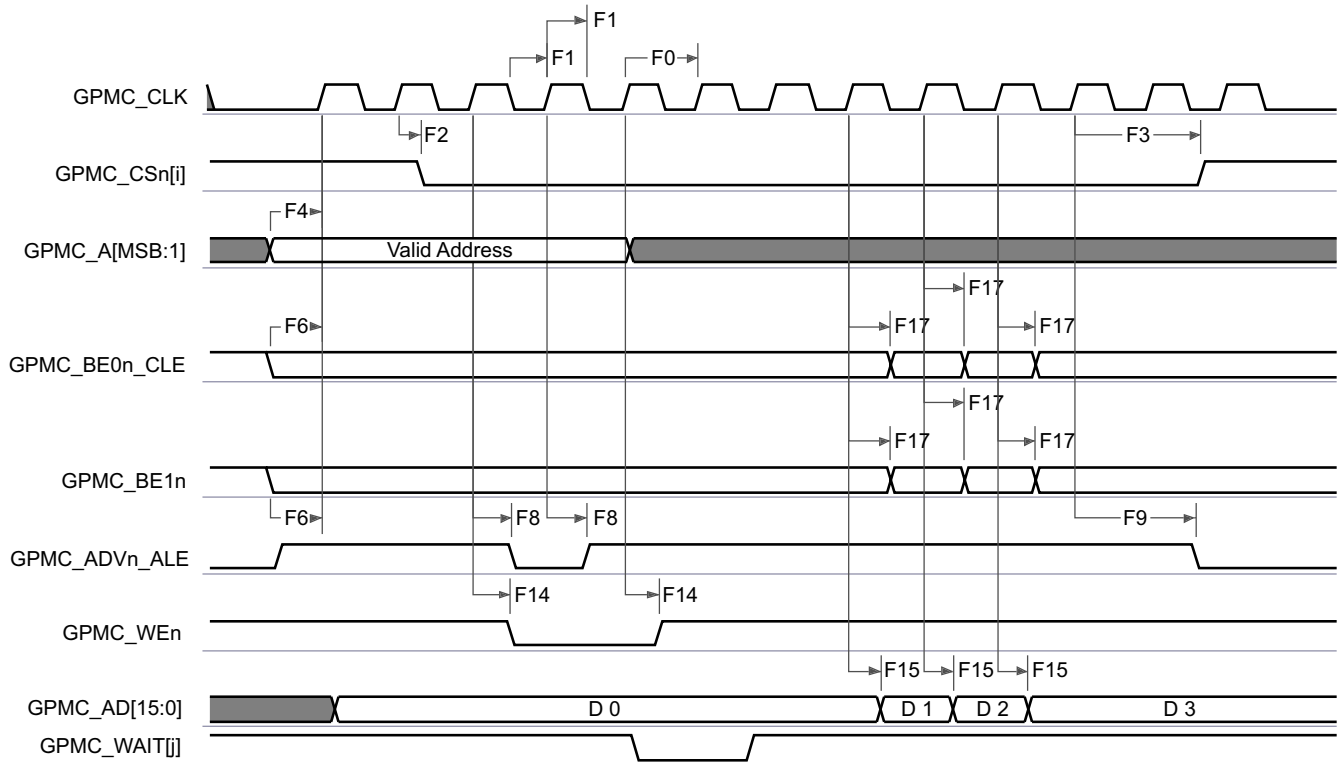

GPMC_03

- A. In GPMC_CS*n*[i], i is equal to 0, 1, 2 or 3.

B. In GPMC_WAIT[j], j is equal to 0 or 1.

Figure 7-59. GPMC and NOR Flash—Synchronous Burst Write (GPMCFCLKDIVIDER = 0)

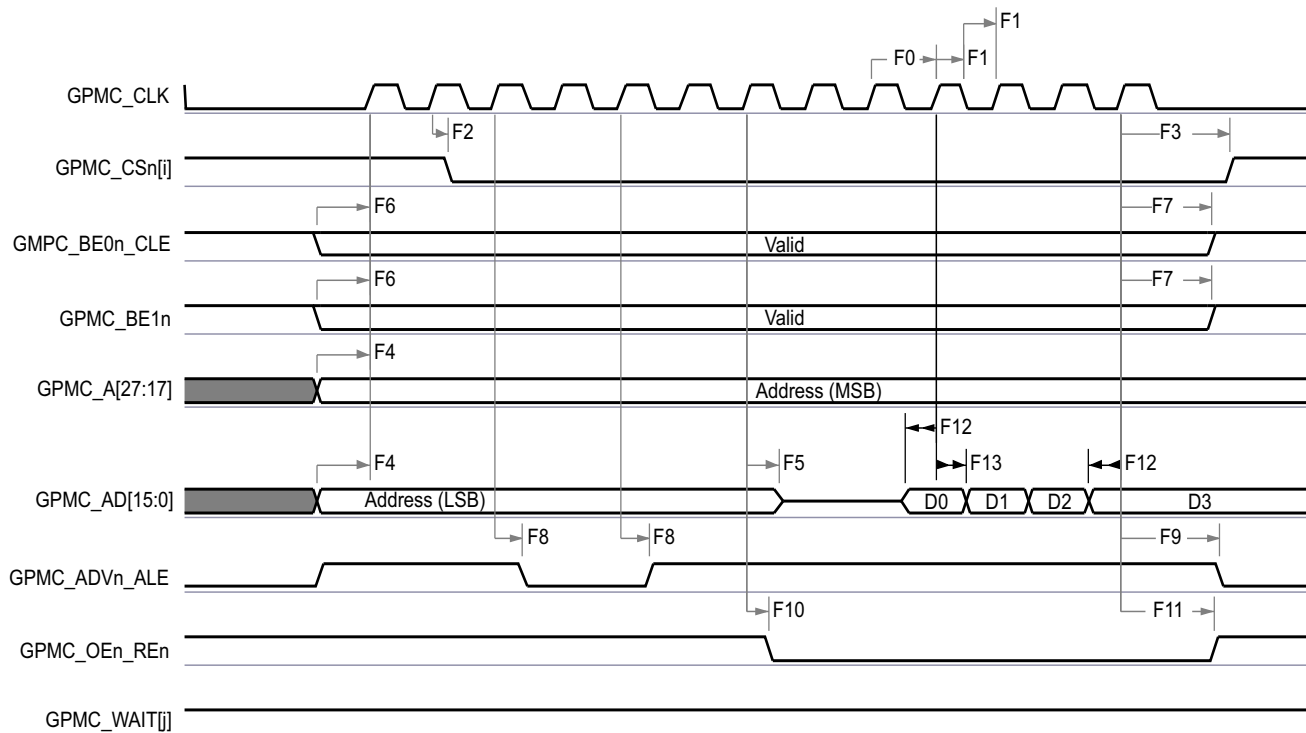

GPMC_04

A. In GPMC_CSn[i], i is equal to 0, 1, 2 or 3.

B. In GPMC_WAIT[j], j is equal to 0 or 1.

Figure 7-60. GPMC and Multiplexed NOR Flash — Synchronous Burst Read

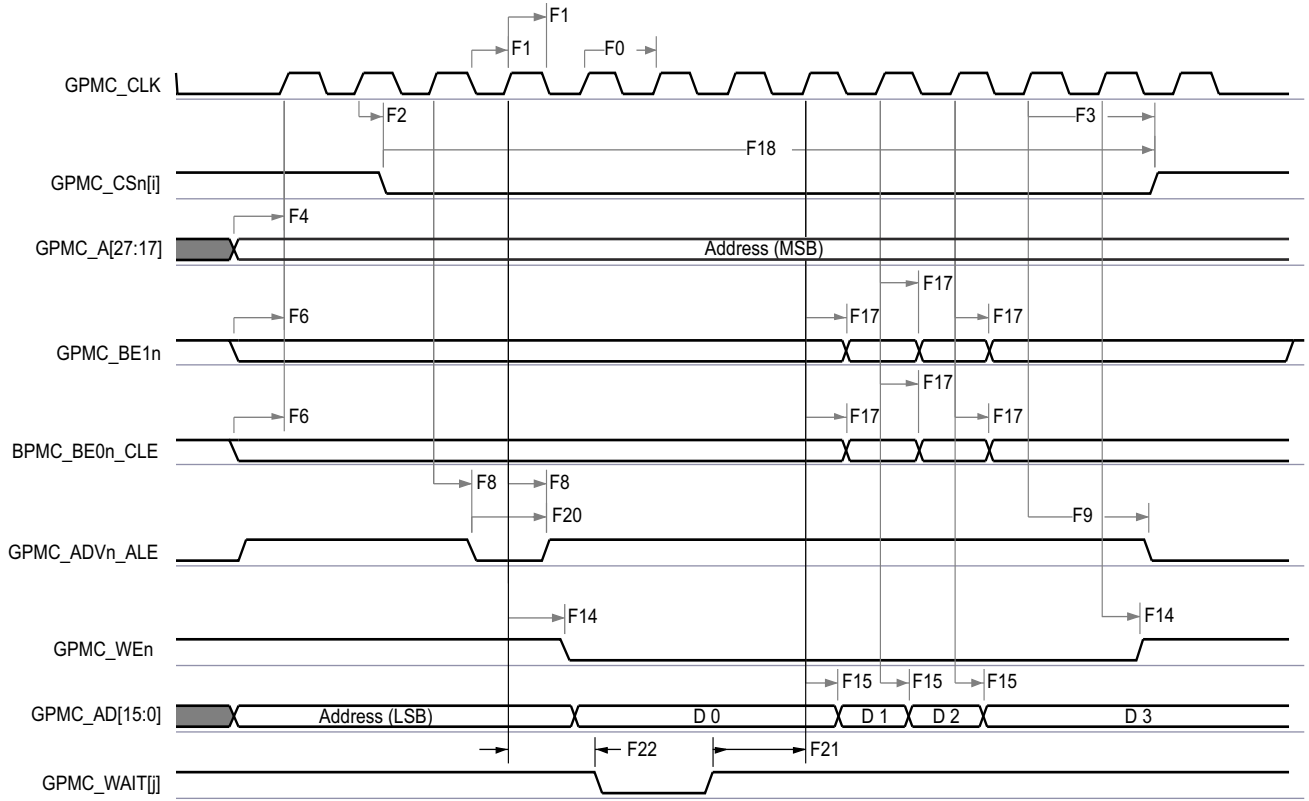

GPMC_05

- A. In GPMC_CS[n], i is equal to 0, 1, 2 or 3.
- B. In GPMC_WAIT[j], j is equal to 0 or 1.

Figure 7-61. GPMC and Multiplexed NOR Flash — Synchronous Burst Write

7.9.5.9.2 GPMC and NOR Flash — Asynchronous Mode

Section 7.9.5.9.2.1 and Section 7.9.5.9.2.2 assume testing over the recommended operating conditions and electrical characteristic conditions below (see Figure 7-62 through Figure 7-67).

7.9.5.9.2.1 GPMC and NOR Flash Timing Requirements – Asynchronous Mode

NO.	PARAMETER	DESCRIPTION	MODE	MIN	MAX	UNIT
FA5 ⁽¹⁾	t _{acc(d)}	Data access time	div_by_1_mode; GPMC_FCLK_MUX; TIMEPARAGRANULARITY_X1		H ⁽⁴⁾	ns
FA2 ₀ ⁽²⁾	t _{acc1-pgmode(d)}	Page mode successive data access time	div_by_1_mode; GPMC_FCLK_MUX; TIMEPARAGRANULARITY_X1		P ⁽³⁾	ns
FA2 ₁ ⁽¹⁾	t _{acc2-pgmode(d)}	Page mode first data access time	div_by_1_mode; GPMC_FCLK_MUX; TIMEPARAGRANULARITY_X1		H ⁽⁴⁾	ns

- (1) The FA5 parameter illustrates the amount of time required to internally sample input data. It is expressed in number of GPMC functional clock cycles. From start of read cycle and after FA5 functional clock cycles, input data is internally sampled by active functional clock edge. FA5 value must be stored inside the AccessTime register bit field.
- (2) The FA20 parameter illustrates amount of time required to internally sample successive input page data. It is expressed in number of GPMC functional clock cycles. After each access to input page data, next input page data is internally sampled by active functional clock edge after FA20 functional clock cycles. The FA20 value must be stored in the PageBurstAccessTime register bit field.
- (3) P = PageBurstAccessTime × (TimeParaGranularity + 1) × GPMC_FCLK⁽⁵⁾
- (4) H = AccessTime × (TimeParaGranularity + 1) × GPMC_FCLK⁽⁵⁾
- (5) GPMC_FCLK is general-purpose memory controller internal functional clock period in ns.

7.9.5.9.2.2 GPMC and NOR Flash Switching Characteristics – Asynchronous Mode

NO.	PARAMETER	DESCRIPTION	MODE ⁽¹⁵⁾	MIN	MAX	UNIT
				133 MHz		
FA0	$t_{w(\text{be}[x]nV)}$	Pulse duration, output lower-byte enable and command latch enable GPMC_BE0n_CLE, output upper-byte enable GPMC_BE1n valid time	Read		N ⁽¹²⁾	ns
			Write		N ⁽¹²⁾	
FA1	$t_{w(\text{csn}V)}$	Pulse duration, output chip select GPMC_CS[n][j] ⁽¹³⁾ low	Read		A ⁽¹⁾	ns
			Write		A ⁽¹⁾	
FA3	$t_{d(\text{csn}V\text{-advn}V)}$	Delay time, output chip select GPMC_CS[n][j] ⁽¹³⁾ valid to output address valid and address latch enable GPMC_ADVn_ALE invalid	Read	-2+B ⁽²⁾	2+B ⁽²⁾	ns
			Write	-2+B ⁽²⁾	2+B ⁽²⁾	
FA4	$t_{d(\text{csn}V\text{-oen}V)}$	Delay time, output chip select GPMC_CS[n][j] ⁽¹³⁾ valid to output enable GPMC_OEn_REn invalid (Single read)	div_by_1_mode; GPMC_FCLK_MUX; TIMEPARAGRANULARITY_X1	-2+C ⁽³⁾	2+C ⁽³⁾	ns
FA9	$t_{d(\text{a}V\text{-csn}V)}$	Delay time, output address GPMC_A[27:1] valid to output chip select GPMC_CS[n][j] ⁽¹³⁾ valid	div_by_1_mode; GPMC_FCLK_MUX; TIMEPARAGRANULARITY_X1	-2+J ⁽⁹⁾	2+J ⁽⁹⁾	ns
FA10	$t_{d(\text{be}[x]nV\text{-csn}V)}$	Delay time, output lower-byte enable and command latch enable GPMC_BE0n_CLE, output upper-byte enable GPMC_BE1n valid to output chip select GPMC_CS[n][j] ⁽¹³⁾ valid	div_by_1_mode; GPMC_FCLK_MUX; TIMEPARAGRANULARITY_X1	-2+J ⁽⁹⁾	2+J ⁽⁹⁾	ns
FA12	$t_{d(\text{csn}V\text{-advn}V)}$	Delay time, output chip select GPMC_CS[n][j] ⁽¹³⁾ valid to output address valid and address latch enable GPMC_ADVn_ALE valid	div_by_1_mode; GPMC_FCLK_MUX; TIMEPARAGRANULARITY_X1	-2+K ⁽¹⁰⁾	2+K ⁽¹⁰⁾	ns
FA13	$t_{d(\text{csn}V\text{-oen}V)}$	Delay time, output chip select GPMC_CS[n][j] ⁽¹³⁾ valid to output enable GPMC_OEn_REn valid	div_by_1_mode; GPMC_FCLK_MUX; TIMEPARAGRANULARITY_X1	-2+L ⁽¹¹⁾	2+L ⁽¹¹⁾	ns
FA16	$t_{w(\text{a}V)}$	Pulse duration output address GPMC_A[26:1] invalid between 2 successive read and write accesses	div_by_1_mode; GPMC_FCLK_MUX; TIMEPARAGRANULARITY_X1	G ⁽⁷⁾		ns
FA18	$t_{d(\text{csn}V\text{-oen}V)}$	Delay time, output chip select GPMC_CS[n][j] ⁽¹³⁾ valid to output enable GPMC_OEn_REn invalid (Burst read)	div_by_1_mode; GPMC_FCLK_MUX; TIMEPARAGRANULARITY_X1	-2+I ⁽⁸⁾	2+I ⁽⁸⁾	ns
FA20	$t_{w(\text{a}V)}$	Pulse duration, output address GPMC_A[27:1] valid - 2nd, 3rd, and 4th accesses	div_by_1_mode; GPMC_FCLK_MUX; TIMEPARAGRANULARITY_X1	D ⁽⁴⁾		ns
FA25	$t_{d(\text{csn}V\text{-wen}V)}$	Delay time, output chip select GPMC_CS[n][j] ⁽¹³⁾ valid to output write enable GPMC_WEn valid	div_by_1_mode; GPMC_FCLK_MUX; TIMEPARAGRANULARITY_X1	-2+E ⁽⁵⁾	2+E ⁽⁵⁾	ns
FA27	$t_{d(\text{csn}V\text{-wen}V)}$	Delay time, output chip select GPMC_CS[n][j] ⁽¹³⁾ valid to output write enable GPMC_WEn invalid	div_by_1_mode; GPMC_FCLK_MUX; TIMEPARAGRANULARITY_X1	-2+F ⁽⁶⁾	2+F ⁽⁶⁾	ns
FA28	$t_{d(\text{wen}V\text{-d}V)}$	Delay time, output write enable GPMC_WEn valid to output data GPMC_AD[15:0] valid	div_by_1_mode; GPMC_FCLK_MUX; TIMEPARAGRANULARITY_X1		2	ns
FA29	$t_{d(\text{d}V\text{-csn}V)}$	Delay time, output data GPMC_AD[15:0] valid to output chip select GPMC_CS[n][j] ⁽¹³⁾ valid	div_by_1_mode; GPMC_FCLK_MUX; TIMEPARAGRANULARITY_X1	-2+J ⁽⁹⁾	2+J ⁽⁹⁾	ns
FA37	$t_{d(\text{oen}V\text{-a}V)}$	Delay time, output enable GPMC_OEn_REn valid to output address GPMC_AD[15:0] phase end	div_by_1_mode; GPMC_FCLK_MUX; TIMEPARAGRANULARITY_X1		2	ns

- (1) For single read: $A = (\text{CSRdOffTime} - \text{CSONTime}) \times (\text{TimeParaGranularity} + 1) \times \text{GPMC_FCLK}^{(14)}$
 For single write: $A = (\text{CSWrOffTime} - \text{CSONTime}) \times (\text{TimeParaGranularity} + 1) \times \text{GPMC_FCLK}^{(14)}$
 For burst read: $A = (\text{CSRdOffTime} - \text{CSONTime} + (n - 1) \times \text{PageBurstAccessTime}) \times (\text{TimeParaGranularity} + 1) \times \text{GPMC_FCLK}^{(14)}$
 For burst write: $A = (\text{CSWrOffTime} - \text{CSONTime} + (n - 1) \times \text{PageBurstAccessTime}) \times (\text{TimeParaGranularity} + 1) \times \text{GPMC_FCLK}^{(14)}$
 with n being the page burst access number
- (2) For reading: $B = ((\text{ADVrdOffTime} - \text{CSONTime}) \times (\text{TimeParaGranularity} + 1) + 0.5 \times (\text{ADVExtraDelay} - \text{CSEExtraDelay})) \times \text{GPMC_FCLK}^{(14)}$

- For writing: $B = ((ADVWrOffTime - CSOnTime) \times (TimeParaGranularity + 1) + 0.5 \times (ADVExtraDelay - CSEExtraDelay)) \times GPMC_FCLK^{(14)}$
- (3) $C = ((OEOffTime - CSOnTime) \times (TimeParaGranularity + 1) + 0.5 \times (OEExtraDelay - CSEExtraDelay)) \times GPMC_FCLK^{(14)}$
- (4) $D = PageBurstAccessTime \times (TimeParaGranularity + 1) \times GPMC_FCLK^{(14)}$
- (5) $E = ((WEOnTime - CSOnTime) \times (TimeParaGranularity + 1) + 0.5 \times (WEEExtraDelay - CSEExtraDelay)) \times GPMC_FCLK^{(14)}$
- (6) $F = ((WEOffTime - CSOnTime) \times (TimeParaGranularity + 1) + 0.5 \times (WEEExtraDelay - CSEExtraDelay)) \times GPMC_FCLK^{(14)}$
- (7) $G = Cycle2CycleDelay \times GPMC_FCLK^{(14)}$
- (8) $I = ((OEOffTime + (n - 1) \times PageBurstAccessTime - CSOnTime) \times (TimeParaGranularity + 1) + 0.5 \times (OEExtraDelay - CSEExtraDelay)) \times GPMC_FCLK^{(14)}$
- (9) $J = (CSOnTime \times (TimeParaGranularity + 1) + 0.5 \times CSEExtraDelay) \times GPMC_FCLK^{(14)}$
- (10) $K = ((ADVOnTime - CSOnTime) \times (TimeParaGranularity + 1) + 0.5 \times (ADVExtraDelay - CSEExtraDelay)) \times GPMC_FCLK^{(14)}$
- (11) $L = ((OEOnTime - CSOnTime) \times (TimeParaGranularity + 1) + 0.5 \times (OEExtraDelay - CSEExtraDelay)) \times GPMC_FCLK^{(14)}$
- (12) For single read: $N = RdCycleTime \times (TimeParaGranularity + 1) \times GPMC_FCLK^{(14)}$
For single write: $N = WrCycleTime \times (TimeParaGranularity + 1) \times GPMC_FCLK^{(14)}$
For burst read: $N = (RdCycleTime + (n - 1) \times PageBurstAccessTime) \times (TimeParaGranularity + 1) \times GPMC_FCLK^{(14)}$
For burst write: $N = (WrCycleTime + (n - 1) \times PageBurstAccessTime) \times (TimeParaGranularity + 1) \times GPMC_FCLK^{(14)}$
- (13) In GPMC_CS*n*[*i*], *i* is equal to 0, 1, 2 or 3.
- (14) GPMC_FCLK is general-purpose memory controller internal functional clock period in ns.
- (15) For div_by_1_mode:
- GPMC_CONFIG1_0 Register: GPMCFCLKDIVIDER = 0h:
 - GPMC_CLK frequency = GPMC_FCLK frequency

For GPMC_FCLK_MUX:

- CTRLMMR_GPMC_CLKSEL[1-0] CLK_SEL = 00 = CPSWHS DIV_CLKOUT3 = 2000/15 = 133.33 MHz

For TIMEPARAGRANULARITY_X1:

- GPMC_CONFIG1_0 Register: TIMEPARAGRANULARITY = 0h = x1 latencies (affecting RD/WRCYCLETIME, RD/WRACCESSTIME, PAGEBURSTACCESSTIME, CSONTIME, CSRD/WROFFTIME, ADVONTIME, ADVRD/WROFFTIME, OEONTIME, OEOFFTIME, WEONTIME, WEOFFTIME, CYCLE2CYCLEDELAY, BUSTURNAROUND, TIMEOUTSTARTVALUE, WRDATAONADMUXBUS)

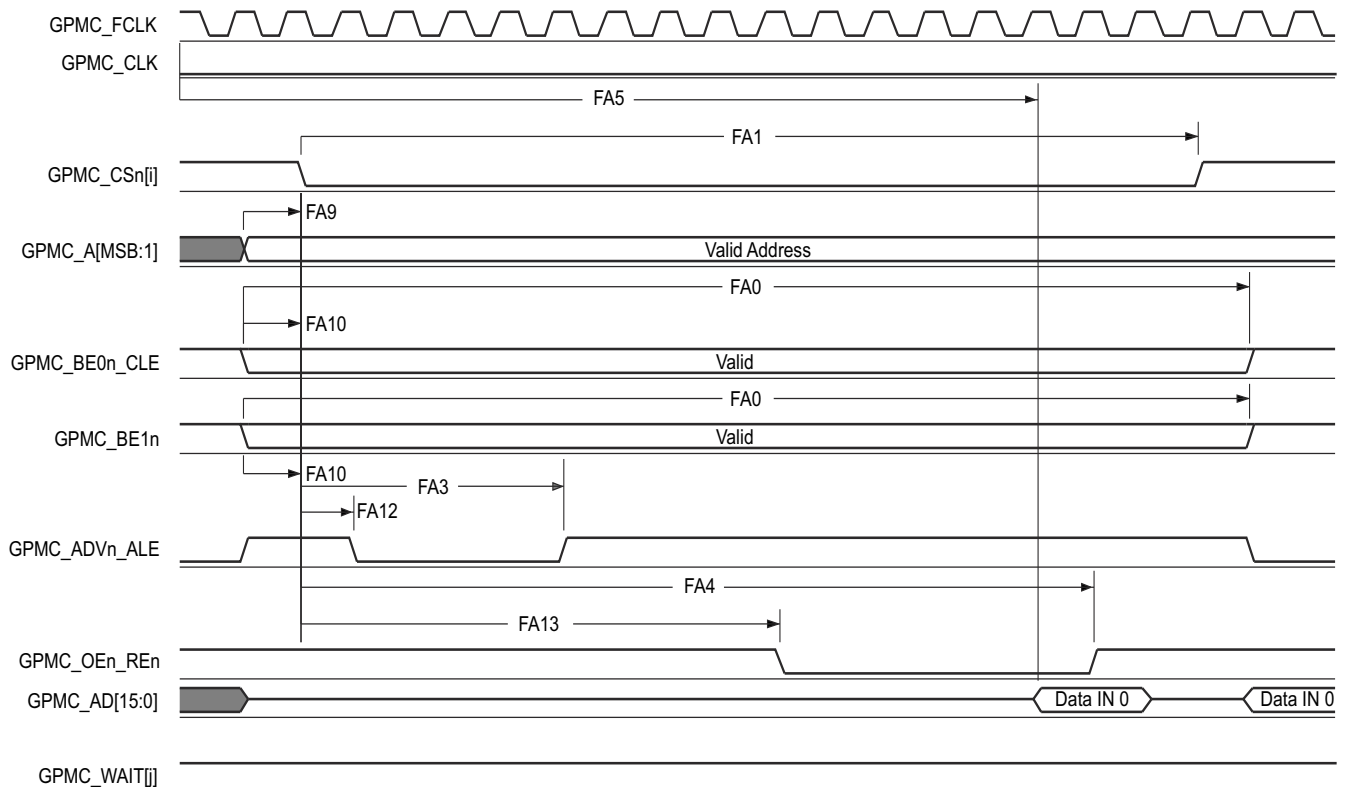

GPMC_06

- A. In GPMC_CS*n*[*i*], *i* is equal to 0, 1, 2 or 3. In GPMC_WAIT[*j*], *j* is equal to 0 or 1.
- B. FA5 parameter illustrates amount of time required to internally sample input data. It is expressed in number of GPMC functional clock cycles. From start of read cycle and after FA5 functional clock cycles, input data will be internally sampled by active functional clock edge. FA5 value must be stored inside AccessTime register bits field.

C. GPMC_FCLK is an internal clock (GPMC functional clock) not provided externally.

Figure 7-62. GPMC and NOR Flash — Asynchronous Read — Single Word

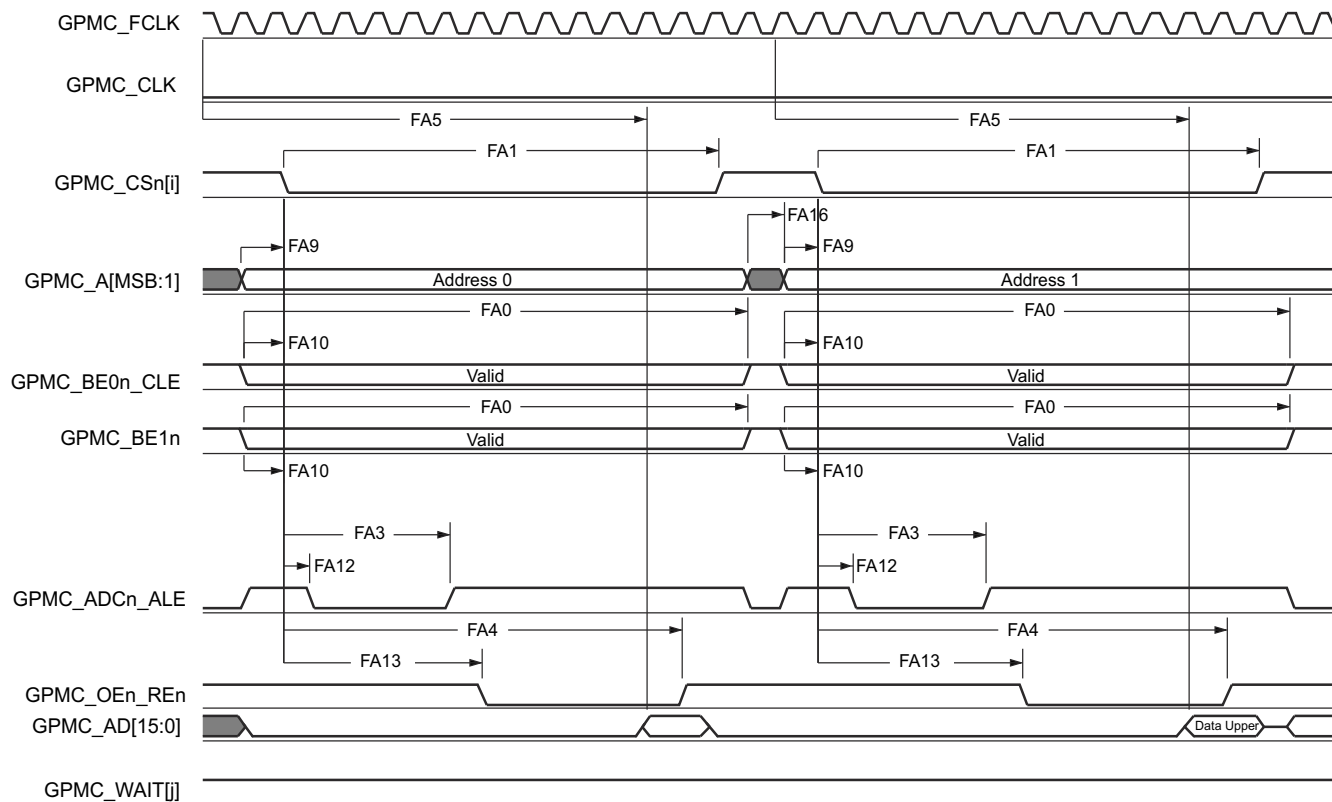

GPMC_07

- A. In GPMC_CS*n*[*i*], *i* is equal to 0, 1, 2 or 3. In GPMC_WAIT[j], *j* is equal to 0 or 1.
- B. FA5 parameter illustrates amount of time required to internally sample input data. It is expressed in number of GPMC functional clock cycles. From start of read cycle and after FA5 functional clock cycles, input data will be internally sampled by active functional clock edge. FA5 value must be stored inside AccessTime register bits field.
- C. GPMC_FCLK is an internal clock (GPMC functional clock) not provided externally.

Figure 7-63. GPMC and NOR Flash — Asynchronous Read — 32-Bit

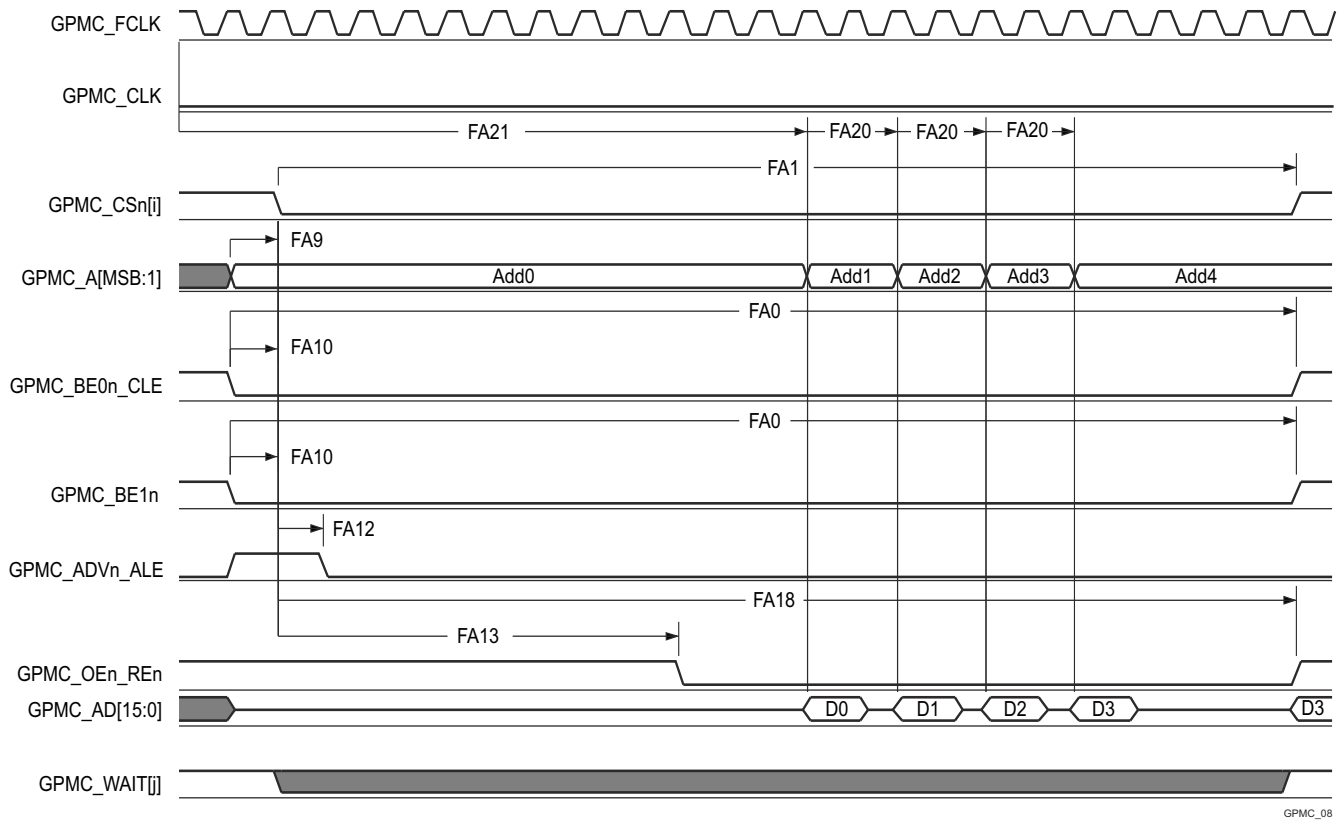

GPMC_08

- A. In GPMC_CS*n*[*i*], *i* is equal to 0, 1, 2 or 3. In GPMC_WAIT[j], *j* is equal to 0 or 1.
- B. FA21 parameter illustrates amount of time required to internally sample first input page data. It is expressed in number of GPMC functional clock cycles. From start of read cycle and after FA21 functional clock cycles, first input page data will be internally sampled by active functional clock edge. FA21 calculation must be stored inside AccessTime register bits field.
- C. FA20 parameter illustrates amount of time required to internally sample successive input page data. It is expressed in number of GPMC functional clock cycles. After each access to input page data, next input page data will be internally sampled by active functional clock edge after FA20 functional clock cycles. FA20 is also the duration of address phases for successive input page data (excluding first input page data). FA20 value must be stored in PageBurstAccessTime register bits field.
- D. GPMC_FCLK is an internal clock (GPMC functional clock) not provided externally.

Figure 7-64. GPMC and NOR Flash — Asynchronous Read — Page Mode 4x16–Bit

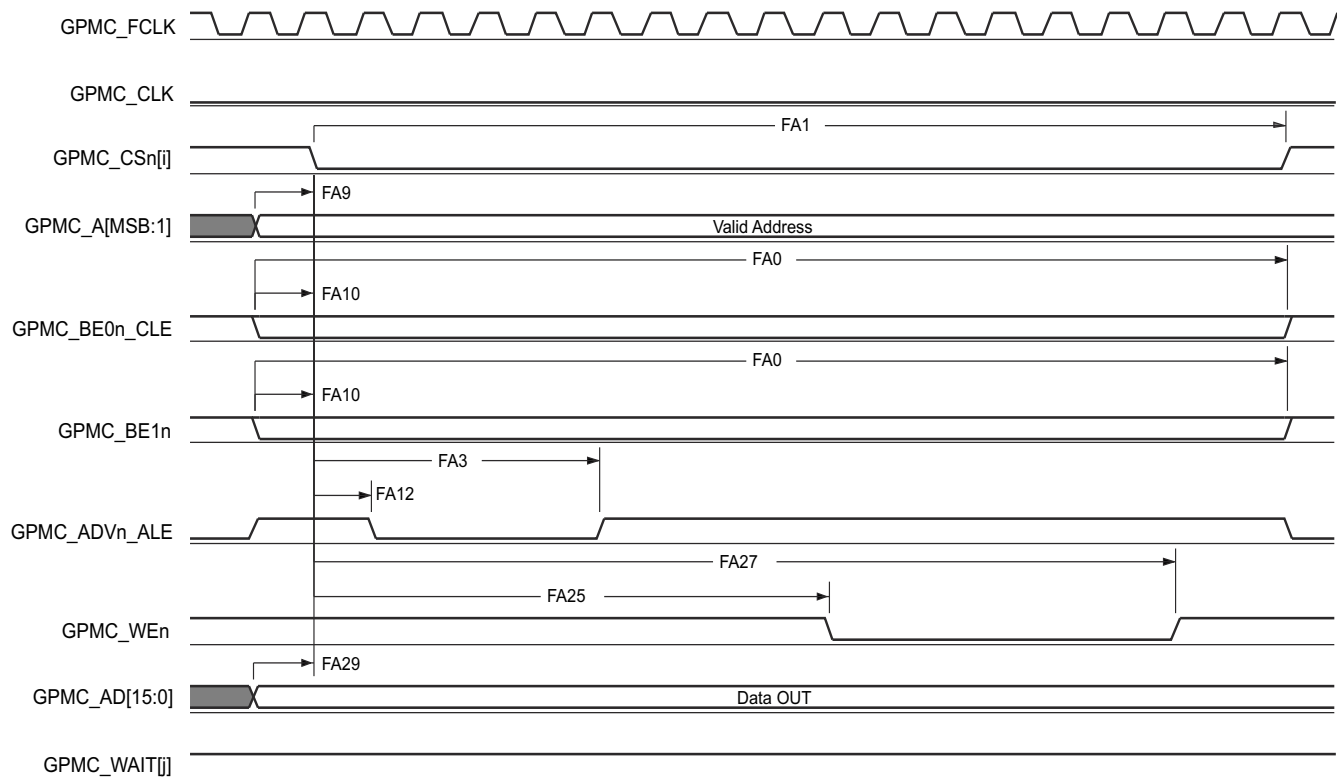

GPMC_09

A. In GPMC_CSn[i], i is equal to 0, 1, 2 or 3. In GPMC_WAIT[j], j is equal to 0 or 1.

Figure 7-65. GPMC and NOR Flash — Asynchronous Write — Single Word

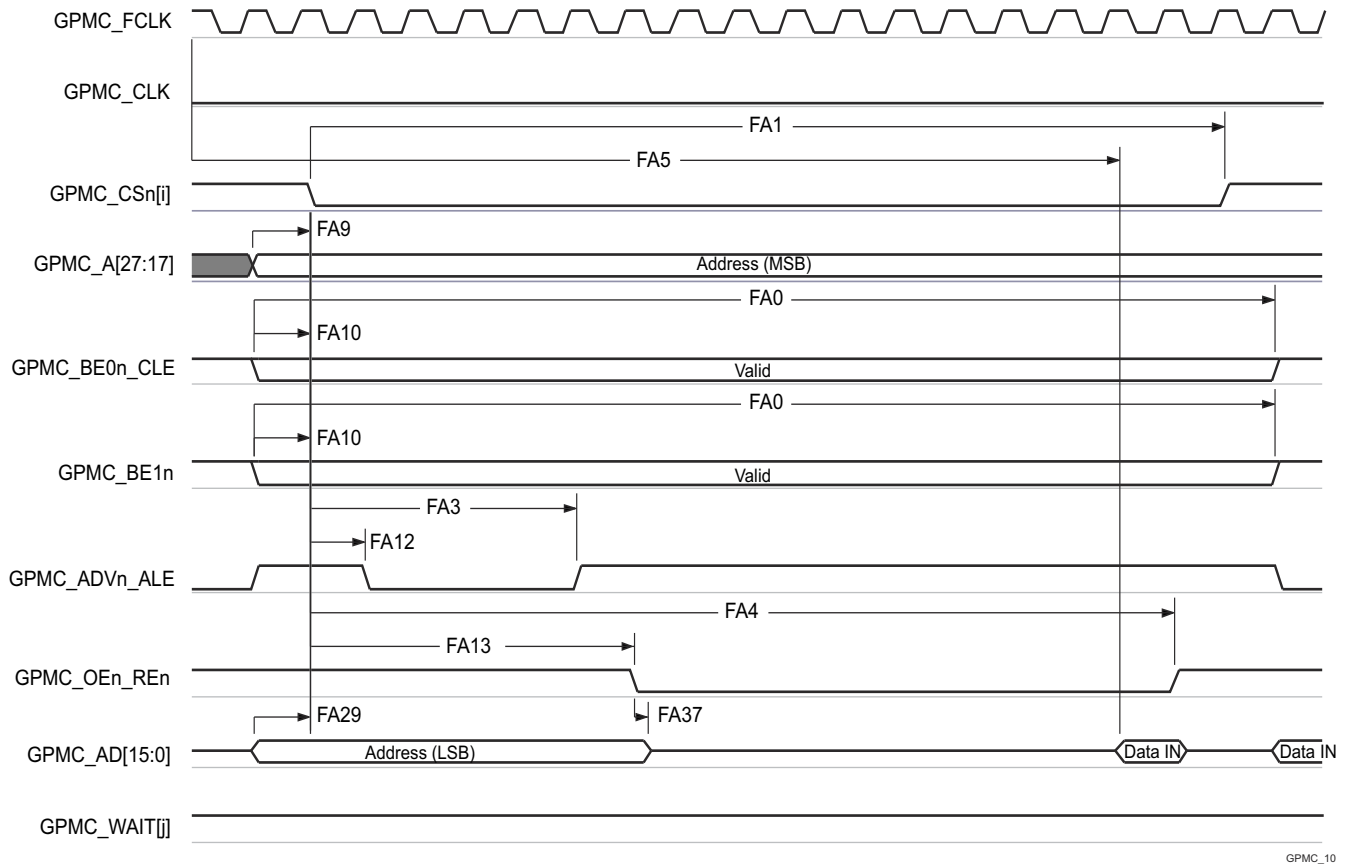

GPMC_10

- In GPMC_CS[n][i], i is equal to 0, 1, 2 or 3. In GPMC_WAIT[j], j is equal to 0 or 1.
- FA5 parameter illustrates amount of time required to internally sample input data. It is expressed in number of GPMC functional clock cycles. From start of read cycle and after FA5 functional clock cycles, input data will be internally sampled by active functional clock edge. FA5 value must be stored inside AccessTime register bits field.
- GPMC_FCLK is an internal clock (GPMC functional clock) not provided externally.

Figure 7-66. GPMC and Multiplexed NOR Flash — Asynchronous Read — Single Word

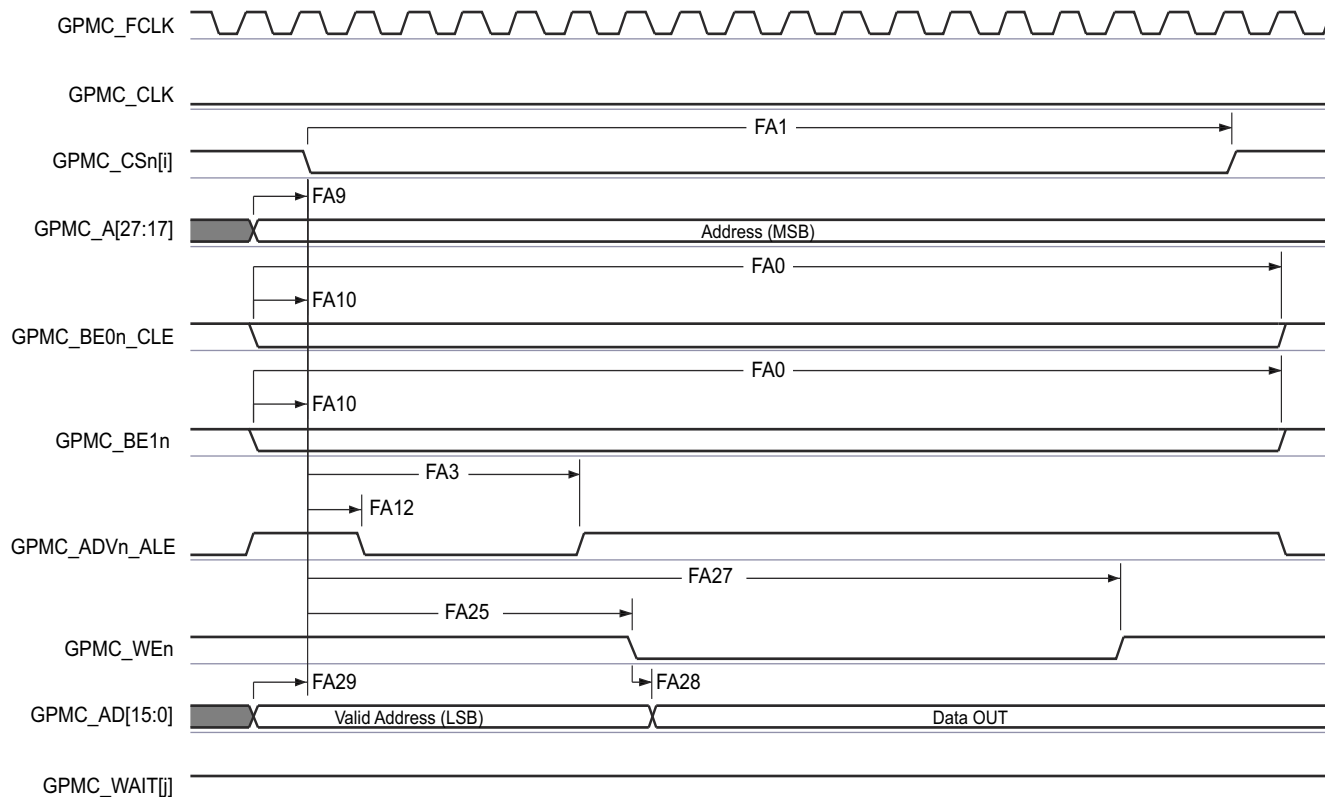

GPMC_11

A. In GPMC_CSn[i], i is equal to 0, 1, 2 or 3. In GPMC_WAIT[j], j is equal to 0 or 1.

Figure 7-67. GPMC and Multiplexed NOR Flash — Asynchronous Write — Single Word

7.9.5.9.3 GPMC and NAND Flash — Asynchronous Mode

Section 7.9.5.9.3.1 and Section 7.9.5.9.3.2 assume testing over the recommended operating conditions and electrical characteristic conditions below (see Figure 7-68 through Figure 7-71).

For more information, see *General-Purpose Memory Controller (GPMC)* section in *Peripherals* chapter in the device TRM.

7.9.5.9.3.1 GPMC and NAND Flash Timing Requirements – Asynchronous Mode

NO.	PARAMETER	DESCRIPTION	MODE ⁽⁴⁾	MIN	MAX	UNIT
				133 MHz		
GNF12 ⁽¹⁾	t _{acc(d)}	Access time, input data GPMC_AD[15:0] ⁽³⁾	div_by_1_mode; GPMC_FCLK_MUX; TIMEPARAGRANULARITY_X1		J ⁽²⁾	ns

(1) The GNF12 parameter illustrates the amount of time required to internally sample input data. It is expressed in number of GPMC functional clock cycles. From start of the read cycle and after GNF12 functional clock cycles, input data is internally sampled by the active functional clock edge. The GNF12 value must be stored inside AccessTime register bit field.

(2) $J = \text{AccessTime} \times (\text{TimeParaGranularity} + 1) \times \text{GPMC_FCLK}^{(3)}$

(3) GPMC_FCLK is general-purpose memory controller internal functional clock period in ns.

(4) For div_by_1_mode:

- GPMC_CONFIG1_i Register: GPMCFCLKDIVIDER = 0h:
 - GPMC_CLK frequency = GPMC_FCLK frequency

For GPMC_FCLK_MUX:

- CTRLMMR_GPMC_CLKSEL[1-0] CLK_SEL = 00 = CPSWHS DIV_CLKOUT3 = 2000/15 = 133.33 MHz

For TIMEPARAGRANULARITY_X1:

- GPMC_CONFIG1_i Register: TIMEPARAGRANULARITY = 0h = x1 latencies (affecting RD/WRCYCLETIME, RD/WRACCESSTIME, PAGEBURSTACCESSTIME, CSONTIME, CSRD/WROFFTIME, ADVONTIME, ADVRD/WROFFTIME, OEONTIME, OEOFFTIME, WEONTIME, WEOFFTIME, CYCLE2CYCLEDELAY, BUSTURNAROUND, TIMEOUTSTARTVALUE, WRDATAONADMUXBUS)

7.9.5.9.3.2 GPMC and NAND Flash Switching Characteristics – Asynchronous Mode

NO.	PARAMETER	DESCRIPTION	MODE ⁽¹⁵⁾	MIN	MAX	UNIT
GNF0	t _{w(wenV)}	Pulse duration, output write enable GPMC_WEN valid	div_by_1_mode; GPMC_FCLK_MUX; TIMEPARAGRANULARITY_X1	A ⁽¹⁾		ns
GNF1	t _{d(csnV-wenV)}	Delay time, output chip select GPMC_CS _n [j] ⁽¹³⁾ valid to output write enable GPMC_WEN valid	div_by_1_mode; GPMC_FCLK_MUX; TIMEPARAGRANULARITY_X1	-2+B ⁽²⁾	2+B ⁽²⁾	ns
GNF2	t _{w(cleH-wenV)}	Delay time, output lower-byte enable and command latch enable GPMC_BE0 _n _CLE high to output write enable GPMC_WEN valid	div_by_1_mode; GPMC_FCLK_MUX; TIMEPARAGRANULARITY_X1	-2+C ⁽³⁾	2+C ⁽³⁾	ns
GNF3	t _{w(wenV-dV)}	Delay time, output data GPMC_AD[15:0] valid to output write enable GPMC_WEN valid	div_by_1_mode; GPMC_FCLK_MUX; TIMEPARAGRANULARITY_X1	-2+D ⁽⁴⁾	2+D ⁽⁴⁾	ns
GNF4	t _{w(wenIV-dIV)}	Delay time, output write enable GPMC_WEN invalid to output data GPMC_AD[15:0] invalid	div_by_1_mode; GPMC_FCLK_MUX; TIMEPARAGRANULARITY_X1	-2+E ⁽⁵⁾	2+E ⁽⁵⁾	ns
GNF5	t _{w(wenIV-cleIV)}	Delay time, output write enable GPMC_WEN invalid to output lower-byte enable and command latch enable GPMC_BE0 _n _CLE invalid	div_by_1_mode; GPMC_FCLK_MUX; TIMEPARAGRANULARITY_X1	-2+F ⁽⁶⁾	2+F ⁽⁶⁾	ns
GNF6	t _{w(wenIV-csn[j]V)}	Delay time, output write enable GPMC_WEN invalid to output chip select GPMC_CS _n [j] ⁽¹³⁾ invalid	div_by_1_mode; GPMC_FCLK_MUX; TIMEPARAGRANULARITY_X1	-2+G ⁽⁷⁾	2+G ⁽⁷⁾	ns
GNF7	t _{w(aleH-wenV)}	Delay time, output address valid and address latch enable GPMC_ADV _n _ALE high to output write enable GPMC_WEN valid	div_by_1_mode; GPMC_FCLK_MUX; TIMEPARAGRANULARITY_X1	-2+C ⁽³⁾	2+C ⁽³⁾	ns

NO.	PARAMETER	MODE ⁽¹⁵⁾	MIN	MAX	UNIT
GNF8	$t_{w(wenIV-aleIV)}$ Delay time, output write enable GPMC_WEn invalid to output address valid and address latch enable GPMC_ADVn_ALE invalid	div_by_1_mode; GPMC_FCLK_MUX; TIMEPARAGRANULARITY_X1	-2+F ⁽⁶⁾	2+F ⁽⁶⁾	ns
GNF9	$t_{c(wen)}$ Cycle time, write	div_by_1_mode; GPMC_FCLK_MUX; TIMEPARAGRANULARITY_X1		H ⁽⁸⁾	ns
GNF10	$t_{d(csnV-oenV)}$ Delay time, output chip select GPMC_CSn[i] ⁽¹³⁾ valid to output enable GPMC_OEn_REn valid	div_by_1_mode; GPMC_FCLK_MUX; TIMEPARAGRANULARITY_X1	-2+I ⁽⁹⁾	2+I ⁽⁹⁾	ns
GNF13	$t_{w(oenV)}$ Pulse duration, output enable GPMC_OEn_REn valid	div_by_1_mode; GPMC_FCLK_MUX; TIMEPARAGRANULARITY_X1		K ⁽¹⁰⁾	ns
GNF14	$t_{c(oen)}$ Cycle time, read	div_by_1_mode; GPMC_FCLK_MUX; TIMEPARAGRANULARITY_X1	L ⁽¹¹⁾		ns
GNF15	$t_{w(oenIV-CSn[i]V)}$ Delay time, output enable GPMC_OEn_REn invalid to output chip select GPMC_CSn[i] ⁽¹³⁾ invalid	div_by_1_mode; GPMC_FCLK_MUX; TIMEPARAGRANULARITY_X1	-2+M ⁽¹²⁾	2+M ⁽¹²⁾	ns

- (1) $A = (WEOffTime - WEOnTime) \times (TimeParaGranularity + 1) \times GPMC_FCLK^{(14)}$
(2) $B = ((WEOnTime - CSOnTime) \times (TimeParaGranularity + 1) + 0.5 \times (WEEExtraDelay - CSEExtraDelay)) \times GPMC_FCLK^{(14)}$
(3) $C = ((WEOnTime - ADVOnTime) \times (TimeParaGranularity + 1) + 0.5 \times (WEEExtraDelay - ADVExtraDelay)) \times GPMC_FCLK^{(14)}$
(4) $D = (WEOnTime \times (TimeParaGranularity + 1) + 0.5 \times WEEExtraDelay) \times GPMC_FCLK^{(14)}$
(5) $E = ((WrCycleTime - WEOffTime) \times (TimeParaGranularity + 1) - 0.5 \times WEEExtraDelay) \times GPMC_FCLK^{(14)}$
(6) $F = ((ADVWrOffTime - WEOffTime) \times (TimeParaGranularity + 1) + 0.5 \times (ADVExtraDelay - WEEExtraDelay)) \times GPMC_FCLK^{(14)}$
(7) $G = ((CSWrOffTime - WEOffTime) \times (TimeParaGranularity + 1) + 0.5 \times (CSEExtraDelay - WEEExtraDelay)) \times GPMC_FCLK^{(14)}$
(8) $H = WrCycleTime \times (1 + TimeParaGranularity) \times GPMC_FCLK^{(14)}$
(9) $I = ((OEOntime - CSOnTime) \times (TimeParaGranularity + 1) + 0.5 \times (OEEExtraDelay - CSEExtraDelay)) \times GPMC_FCLK^{(14)}$
(10) $K = (OEOntime - OEOntime) \times (1 + TimeParaGranularity) \times GPMC_FCLK^{(14)}$
(11) $L = RdCycleTime \times (1 + TimeParaGranularity) \times GPMC_FCLK^{(14)}$
(12) $M = ((CSRdOffTime - OEOntime) \times (TimeParaGranularity + 1) + 0.5 \times (CSEExtraDelay - OEEExtraDelay)) \times GPMC_FCLK^{(14)}$
(13) In GPMC_CSn[i], i is equal to 0, 1, 2 or 3.
(14) GPMC_FCLK is general-purpose memory controller internal functional clock period in ns.
(15) For div_by_1_mode:

- GPMC_CONFIG1_i Register: GPMCFCLKDIVIDER = 0h:
– GPMC_CLK frequency = GPMC_FCLK frequency

For GPMC_FCLK_MUX:

- CTRLMMR_GPMC_CLKSEL[1-0] CLK_SEL = 00 = CPSWHS DIV_CLKOUT3 = 2000/15 = 133.33 MHz

For TIMEPARAGRANULARITY_X1:

- GPMC_CONFIG1_i Register: TIMEPARAGRANULARITY = 0h = x1 latencies (affecting RD/WRCYCLETIME, RD/WRACCESSTIME, PAGEBURSTACCESSTIME, CSONTIME, CSRd/WROFFTIME, ADVONTIME, ADVRD/WROFFTIME, OEONTIME, OEOFFTIME, WEONTIME, WEOFFTIME, CYCLE2CYCLEDELAY, BUSTURNAROUND, TIMEOUTSTARTVALUE, WRDATAONADMUXBUS)

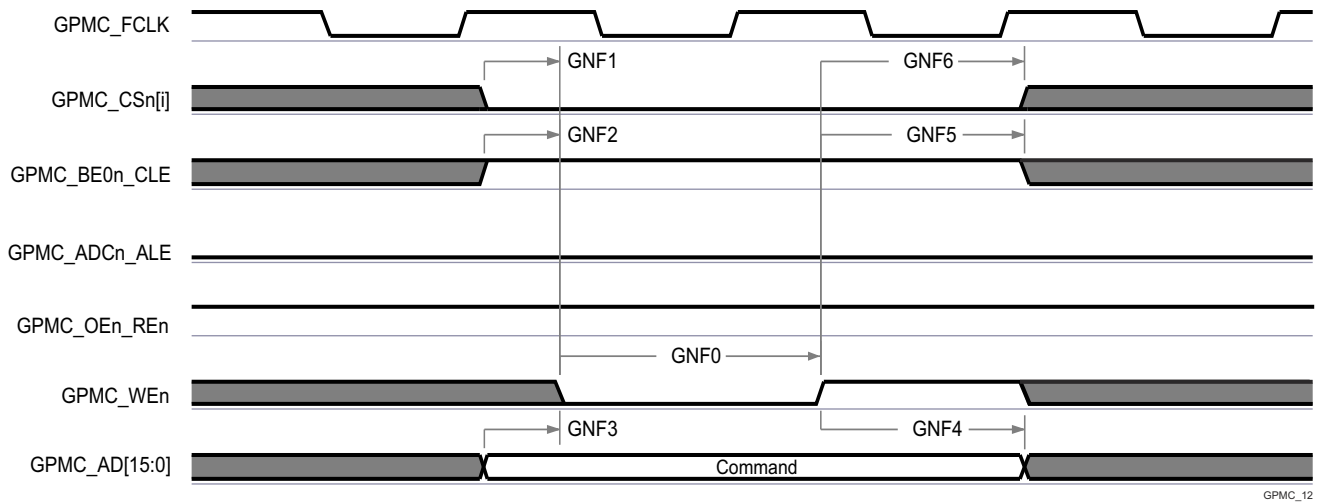

GPMC_12

A. In GPMC_CSn[i], i is equal to 0, 1, 2 or 3.

Figure 7-68. GPMC and NAND Flash — Command Latch Cycle

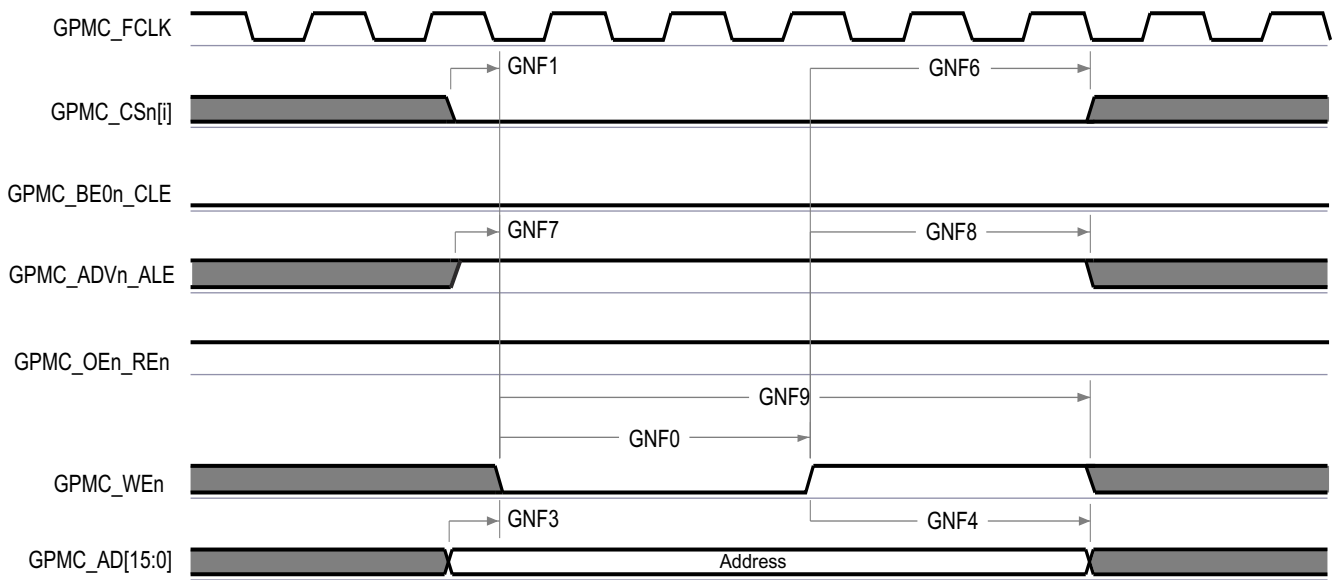

GPMC_13

A. In GPMC_CSn[i], i is equal to 0, 1, 2 or 3.

Figure 7-69. GPMC and NAND Flash — Address Latch Cycle

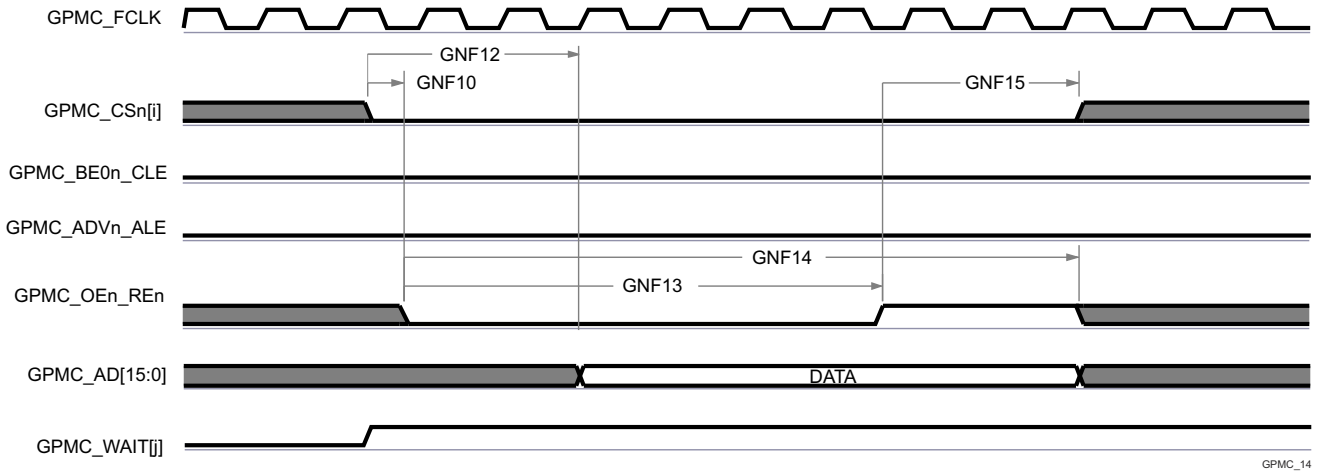

GPMC_14

- A. GNF12 parameter illustrates amount of time required to internally sample input data. It is expressed in number of GPMC functional clock cycles. From start of read cycle and after GNF12 functional clock cycles, input data will be internally sampled by active functional clock edge. GNF12 value must be stored inside AccessTime register bits field.
- B. GPMC_FCLK is an internal clock (GPMC functional clock) not provided externally.
- C. In GPMC_CS*n*[*i*], *i* is equal to 0, 1, 2 or 3. In GPMC_WAIT[j], *j* is equal to 0 or 1.

Figure 7-70. GPMC and NAND Flash — Data Read Cycle

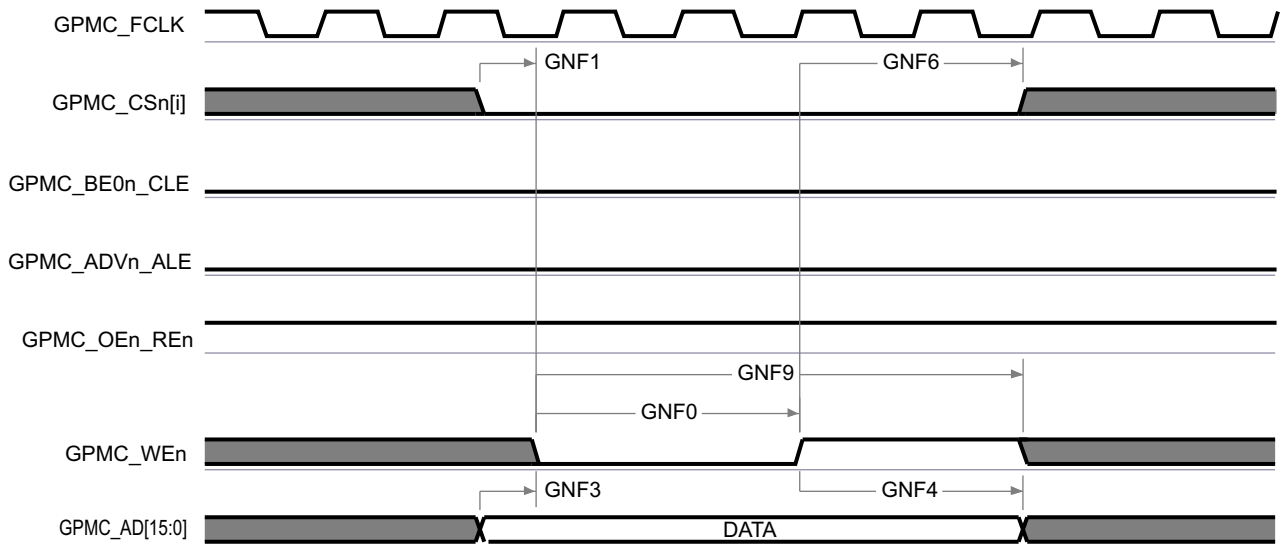

GPMC_15

- A. In GPMC_CS*n*[*i*], *i* is equal to 0, 1, 2 or 3.

Figure 7-71. GPMC and NAND Flash — Data Write Cycle

7.9.5.10 HyperBus

For more details about features and additional description information on the device HyperBus, see the corresponding sections within [Section 6.3, Signal Descriptions](#) and [Section 8, Detailed Description](#).

[Section 7.9.5.10.1](#), [Section 7.9.5.10.2](#), and [Section 7.9.5.10.3](#) assume testing over the recommended operating conditions and electrical characteristic conditions (see [Figure 7-72](#), [Figure 7-73](#), and [Figure 7-74](#)).

[Table 7-41](#) represents HyperBus timing conditions.

Table 7-41. HyperBus Timing Conditions

PARAMETER	DESCRIPTION	MIN	MAX	UNIT
Input Conditions				

Table 7-41. HyperBus Timing Conditions (continued)

PARAMETER	DESCRIPTION	MIN	MAX	UNIT
t_{SR}	Input slew rate	2	5	V/ns
Output Conditions				
C_{LOAD}	Output load capacitance	1.5	10	pF

7.9.5.10.1 Timing Requirements for HyperBus Initialization

NO.	PARAMETER	DESCRIPTION	MIN	MAX	UNIT
D1	$t_{w(RESETn)}$	RESETn Pulse Width	200		ns
D2	$t_{w(csL)}$	Chip Select Pulse Width	1000		ns
D3	$t_{d(RESETnH-csL)}$	Delay time, RESETn inactive to CSn active	200.34		ns
D4	$t_{d(csL-RWDSL)}$	Delay time, CSn active to RWDS falling	115		ns

7.9.5.10.2 HyperBus 166 MHz Switching Characteristics

NO.	PARAMETER	DESCRIPTION	MIN	MAX	UNIT
D5	$t_{skn(rwdsX-dV)}$	Input skew, RWDS transitioning to D0:D7 valid	-0.46	0.46	ns
D6	$t_{c(clk/clkn)}$	CLK period, CLK/CLKn	6		ns
D7	$t_{w(clk/clkn)}$	Pulse width, CLK/CLKn	2.7		ns
D8	$t_{w(csIV)}$	Pulse width, CS0 invalid between operations	6		ns
D9	$t_{d(clkH-csL)}$	Delay time, CS0 active to CLK rising/ CLKn falling		-3.34	ns
D10	$t_{d(clkL[LE]-csH)}$	Delay time, last falling CLK/ rising CLKn edge to CS0 inactive	0.41		ns
D11	$t_{d(clkX-rwdsV)}$	Delay time, CLK transition to RWDS valid	1.01	2.08	ns
D12	$t_{d(clkX-d[0:7]V)}$	Delay time, CLK transitioning to D0:D7 valid	0.84	2.17	ns

7.9.5.10.3 HyperBus 100 MHz Switching Characteristics

NO.	PARAMETER	DESCRIPTION	MIN	MAX	UNIT
LFD5	$t_{skn(rwdsX-dV)}$	Input skew, RWDS transitioning to D0:D7 valid	-0.81	0.81	ns
LFD6	$t_{c(clk)}$	CLK period, CLK	10		ns
LFD7	$t_{w(clk)}$	Pulse width, CLK	4.75		ns
LFD8	$t_{w(csIV)}$	Pulse width, CS0 invalid between operations	10		ns
LFD9	$t_{d(clkH-csL)}$	Delay time, CS0 active to CLK rising		-3.51	ns
LFD10	$t_{d(clkL[LE]-csH)}$	Delay time, last falling CLK edge to CS0 inactive	0.51		ns
LFD11	$t_{d(clkX-rwdsV)}$	Delay time, CLK transition to RWDS valid	1.51	3.49	ns
LFD12	$t_{d(clkX-d[0:7]V)}$	Delay time, CLK transitioning to D0:D7 valid	1.34	3.66	ns

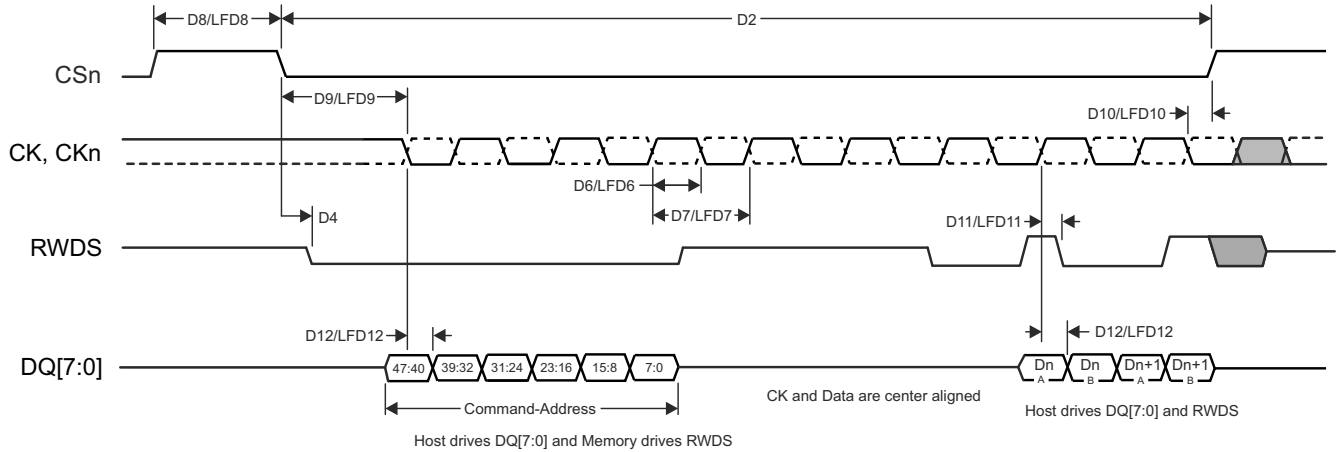

HYPERBUS_TIMING_01

Figure 7-72. HyperBus Timing Diagrams – Transmitter Mode

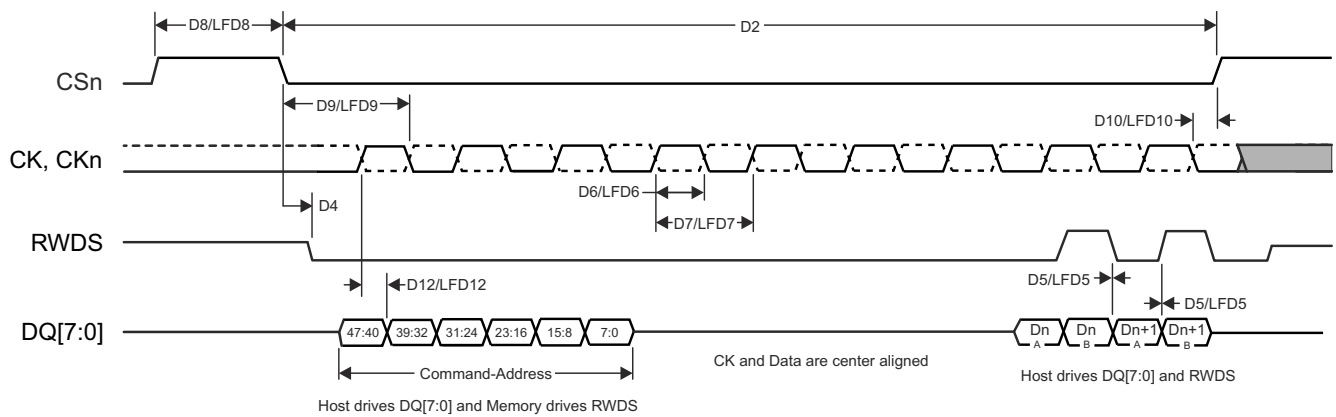

HYPERBUS_TIMING_02

Figure 7-73. HyperBus Timing Diagrams – Receiver Mode

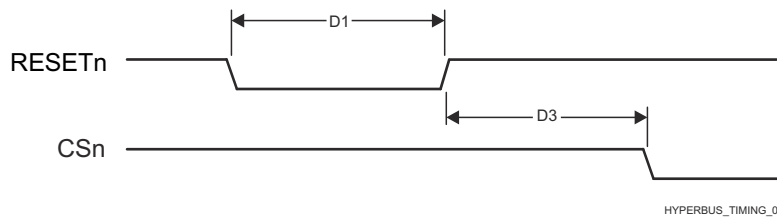

HYPERBUS_TIMING_03

Figure 7-74. HyperBus Timing Diagrams – Reset

For more information, see *HyperBus Interface* section in *Peripherals* chapter in the device TRM.

7.9.5.11 I2C

The device contains six multicontroller Inter-Integrated Circuit (I2C) controllers. Each I2C controller was designed to be compliant to the Philips I2C-bus™ specification version 2.1. However, the device IOs are not fully compliant to the I2C electrical specification. The speeds supported and exceptions are described per port below:

- MCU_I2C1, I2C1, I2C2, I2C3, I2C4, I2C5 and I2C6
 - Speeds:
 - Standard-mode (up to 100 Kbits/s)
 - 1.8 V
 - 3.3 V

- Fast-mode (up to 400 Kbits/s)
 - 1.8 V
 - 3.3 V
- Exceptions:
 - The IOs associated with these ports are not compliant to the fall time requirements defined in the I2C specification because they are implemented with higher performance LVCMOS push-pull IOs that were designed to support other signal functions that could not be implemented with I2C compatible IOs. The LVCMOS IOs being used on these ports are connected such they emulate open-drain outputs. This emulation is achieved by forcing a constant low output and disabling the output buffer to enter the Hi-Z state.
 - The I2C specification defines a maximum input voltage V_{IH} of $(V_{DD_{max}} + 0.5 V)$, which exceeds the absolute maximum ratings for the device IOs. The system must be designed to ensure the I2C signals never exceed the limits defined in the *Absolute Maximum Ratings* section of this datasheet.
- WAKEUP_I2C0, MCU_I2C0, and I2C0
 - Speeds:
 - Standard-mode (up to 100 Kbits/s)
 - 1.8 V
 - 3.3 V
 - Fast-mode (up to 400 Kbits/s)
 - 1.8 V
 - 3.3 V
 - Hs-mode (up to 3.4 Mbit/s)
 - 1.8 V
 - Exceptions:
 - The IOs associated with these ports were not design to support Hs-mode while operating at 3.3 V. So Hs-mode is limited to 1.8-V operation.
 - The rise and fall times of the I2C signals connected to these ports must not exceed a slew rate of 0.8 V/ns (or 8E+7 V/s). This limit is more restrictive than the minimum fall time limits defined in the I2C specification. Therefore, it may be necessary to add additional capacitance to the I2C signals to slow the rise and fall times such that they do not exceed a slew rate of 0.8 V/ns.
 - The I2C specification defines a maximum input voltage V_{IH} of $(V_{DD_{max}} + 0.5 V)$, which exceeds the absolute maximum ratings for the device IOs. The system must be designed to ensure the I2C signals never exceed the limits defined in the *Absolute Maximum Ratings* section of this datasheet.

Refer to the Philips I2C-bus specification version 2.1 for timing details.

For more details about features and additional description information on the device Inter-Integrated Circuit, see the corresponding subsections within *Signal Descriptions* and *Detailed Description* sections.

7.9.5.12 I3C

For more details about features and additional description information on the device Inter-Integrated Circuit, see the corresponding sections within [Section 6.3](#), *Signal Descriptions* and [Section 8](#), *Detailed Description*.

[Table 7-42](#), [Table 7-43](#), [Figure 7-75](#), [Table 7-44](#), and [Figure 7-76](#) assume testing over the recommended operating conditions and electrical characteristic conditions.

Table 7-42. I3C Open Drain Timing Conditions

PARAMETER		MIN	MAX	UNIT
INPUT CONDITIONS				
SR _I	Input slew rate	0.2276	5	V/ns
OUTPUT CONDITIONS				
C _L	Output load capacitance		50	pF

Table 7-43. I3C Open Drain Timing Parameters

NO.	PARAMETER	DESCRIPTION	MODE	MIN	MAX	UNIT
D1	t_{LOW_OD}	Low Period of SCL Clock	Controller	200		ns
	$t_{DIG_OD_L}$			$t_{LOW_OD\ MIN} + t_{FDA_OD\ MIN}$		ns
D2	t_{HIGH}	High Period of SCL Clock	Controller		41	ns
	t_{DIG_H}			$t_{HIGH} + t_{CF}$		ns
D3	t_{FDA_OD}	Fall Time of SDA Signal	Controller, Target	t_{CF}	12	ns
D4	t_{SU_OD}	SDA Data Setup Time During Open Drain Mode	Controller, Target	3		ns
D5	t_{CAS}	Clock After START (S) Condition	Controller, ENTAS0	38.4	1000	ns
			Controller, ENTAS1	38.4	100000	ns
			Controller, ENTAS2	38.4	2000000	ns
			Controller, ENTAS3	38.4	50000000	ns
D6	t_{CBP}	Clock Before STOP (P) Condition	Controller	$t_{CAS\ MIN} / 2$		ns
D7	$t_{MMOVEOVLAP}$	Current Controller to Secondary Controller Overlap time during handoff	Controller	$t_{DIG_OD_L\ min}$		ns
D8	t_{AVAL}	Bus Available Condition	Controller	1000		ns
D9	t_{IDLE}	Bus Idle Condition	Controller	1000000		ns
D10	t_{MMLCK}	Time Interval Where New Controller Not Driving SDA Low	Controller	$t_{AVAL\ min}$		ns

1. This is approximately equal to $t_{LOW\ min} + t_{DS_OD\ min} + t_{rDA_OD\ typ} + t_{SU_OD\ min}$.
2. The Controller may use a shorter Low period if the Controller knows that this is safe, when SDA is already above V_{IH} .
3. Based on t_{SPIKE} , rise and fall times, and interconnect.
4. This maximum High period may be exceeded when the signals can be safely seen by Legacy I2C Devices, and/or in consideration of the interconnect (for example: a short Bus).
5. On a Legacy Bus where I2C Devices need to see Start, the t_{CAS} Min value is further constrained.
6. Targets that do not support the optional ENTASx CCCs shall use the t_{CAS} Max value shown for ENTAS3.
7. On a Mixed Bus with Fm Legacy I2C Devices, t_{AVAL} is 300ns shorter than the Fm Bus Free Condition time (t_{BUF}).

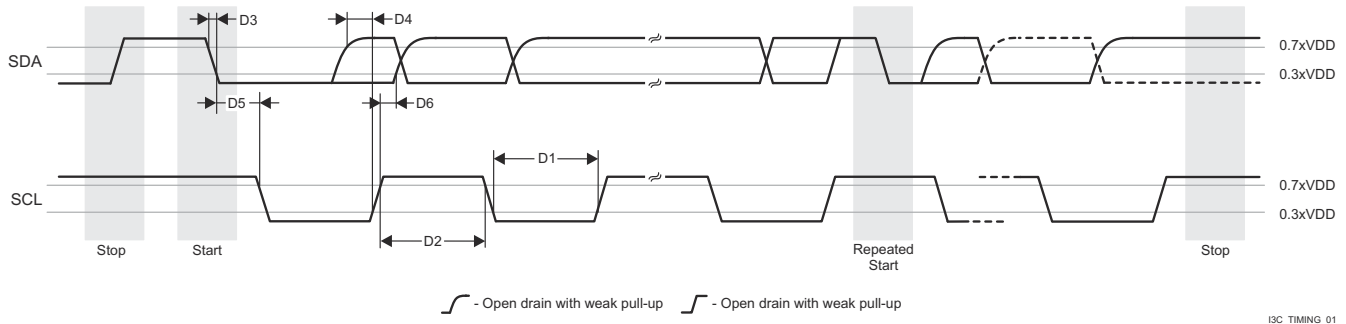

Figure 7-75. I3C Open Drain Timing

Table 7-44. I3C Push-Pull Timing Parameters for SDR and HDR-DDR Modes

NO.	PARAMETER	DESCRIPTION	MODE	MIN	MAX	UNIT
D1	f_{SCL}	SCL Clock Period	Controller	80	100000	ns

Table 7-44. I3C Push-Pull Timing Parameters for SDR and HDR-DDR Modes (continued)

NO.	PARAMETER	DESCRIPTION	MODE	MIN	MAX	UNIT
D2	t_{LOW}	SCL Clock Low Period	Controller	24		ns
	t_{DIG_L}			32		ns
D3	t_{HIGH_MIXED}	SCL Clock High Period of Mixed Bus (Mixed Bus Topology Not Supported)	Controller	24		ns
	$t_{DIG_H_MIXED}$			32	45	ns
D4	t_{HIGH}	SCL Clock High Period	Controller	24		ns
	t_{DIG_H}			32		ns
D5	t_{SCO}	Clock in to Data Out for Target	Target	12		ns
D6	t_{CR}	SCL Clock Rise Time	Controller	$150 \times 1 / f_{SCL}$	60	ns
D7	t_{CF}	SCL Clock Fall Time	Controller	$150 \times 1 / f_{SCL}$	60	ns
D8	t_{HD_PP}	SDA Signal Data Hold in Push Pull Mode	Controller	$t_{CR} + 3$ and $t_{CF} + 3$		ns
			Target	0		ns
D9	t_{SU_PP}	SDA Signal Data Setup In Push-Pull Mode	Controller, Target	3		ns
D10	t_{CASr}	Clock After Repeated START (Sr)	Controller	$t_{CAS\ MIN}$		ns
D11	t_{CBSr}	Clock Before Repeated START (Sr)	Controller	$t_{CAS\ MIN} / 2$		ns

1. $f_{SCL} = 1 / (t_{DIG_L} + t_{DIG_H})$
2. t_{DIG_L} and t_{DIG_H} are the clock Low and High periods as seen at the receiver end of the I3C Bus using V_{IL} and V_{IH} .
3. When communicating with an I3C Device on a mixed Bus, the $t_{DIG_H_MIXED}$ period must be constrained to make sure that I2C Devices do not interpret I3C signaling as valid I2C signaling.
4. As both edges are used, the hold time needs to be satisfied for the respective edges; $t_{CF} + 3$ for falling edge clocks, and $t_{CR} + 3$ for rising edge clocks.
5. Clock Frequency Minimum 0.01 MHz, Maximum 12.5 MHz

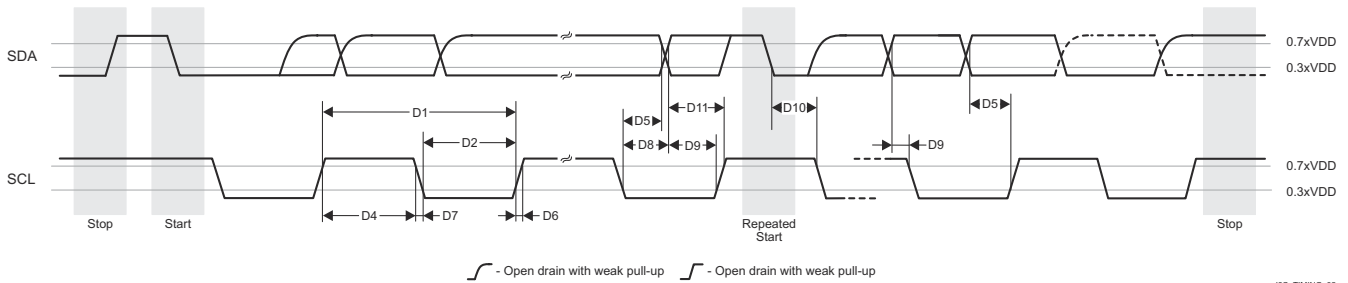

Figure 7-76. I3C Push-Pull Timing (SDR and HDR-DDR Modes)

7.9.5.13 MCAN

Table 7-45 and Table 7-46 presents timing conditions and switching characteristics for MCAN.

For more details about features and additional description information on the device Controller Area Network Interface, see the corresponding subsections within *Signal Descriptions* and *Detailed Description* sections.

Note

The device has multiple MCAN modules. MCANn is a generic prefix applied to MCAN signal names, where n represents the specific MCAN module.

Table 7-45. MCAN Timing Conditions

PARAMETER		MIN	MAX	UNIT
INPUT CONDITIONS				
SR _i	Input slew rate	2	15	V/ns
OUTPUT CONDITIONS				
C _L	Output load capacitance	5	20	pF

Table 7-46. MCAN Switching Characteristics

NO.	PARAMETER	DESCRIPTION	MIN	MAX	UNIT
MCAN1	t _{d(MCAN_TX)}	Delay time, transmit shift register to MCANn_TX		10	ns
MCAN2	t _{d(MCAN_RX)}	Delay time, MCANn_RX to receive shift register		10	ns

For more information, see *Controller Area Network (MCAN)* section in *Peripherals* chapter in the device TRM.

7.9.5.14 MCASP

For more details about features and additional description information on the device Multichannel Audio Serial Port, see the corresponding sections within [Section 6.3](#), *Signal Descriptions* and [Section 8](#), *Detailed Description*.

[Section 7.9.5.14.1](#) and [Figure 7-77](#) present timing requirements for MCASP0 to MCASP11.

Table 7-47. MCASP Timing Conditions

PARAMETER	DESCRIPTION	MIN	MAX	UNIT
Input Conditions				
SR _i	Input slew rate	0.7	5	V/ns
Output Conditions				
C _L	Output load capacitance	1	10	pF
PCB Connectivity Requirements				
t _{d(Trace Delay)}	Propagation delay of each trace	100	1100	ps
t _{d(Trace Mismatch Delay)}	Propagation mismatch across all traces		100	ps

7.9.5.14.1 Timing Requirements for MCASP

NO.1	PARAMETER	DESCRIPTION	MODE	MIN	MAX	UNIT
ASP1	t _{c(AHCLKRX)}	Cycle time, AHCLKR/X		15.26		ns
ASP2	t _{w(AHCLKRX)}	Pulse duration, AHCLKR/X high or low		-1.53 + 0.5P ²		ns
ASP3	t _{c(ACLKRX)}	Cycle time, ACLKR/X		15.26		ns
ASP4	t _{w(ACLKRX)}	Pulse duration, ACLKR/X high or low		-1.53 + 0.5R ³		ns
ASP5	t _{su(AFSRX-ACLKRX)}	Setup time, AFSR/X input valid before ACLKR/X	ACLKR/X int	12.3		ns
			ACLKR/X ext in/out	4		

NO.1	PARAMETER	DESCRIPTION	MODE	MIN	MAX	UNIT
ASP6	$t_{h(ACLKRX-AFSRX)}$	Hold time, AFSR/X input valid after ACLKR/X	ACLKR/X int	-1		ns
			ACLKR/X ext in/out	1.6		
ASP7	$t_{su(AXR-ACLKRX)}$	Setup time, AXR input valid before ACLKR/X	ACLKR/X int	12.3		ns
			ACLKR/X ext in/out	4		
ASP8	$t_{h(ACLKRX-AXR)}$	Hold time, AXR input valid after ACLKR/X	ACLKR/X int	-1		ns
			ACLKR/X ext in/out	1.6		

1. ACLKR internal: ACLKRCTL.CLKRM=1, PDIR.ACLKR = 1
 ACLKR external input: ACLKRCTL.CLKRM=0, PDIR.ACLKR=0
 ACLKR external output: ACLKRCTL.CLKRM=0, PDIR.ACLKR=1
 ACLKX internal: ACLKXCTL.CLKXM=1, PDIR.ACLKX = 1
 ACLKX external input: ACLKXCTL.CLKXM=0, PDIR.ACLKX=0
 ACLKX external output: ACLKXCTL.CLKXM=0, PDIR.ACLKX=1
2. P = AHCLKR/X period in ns.
3. R = ACLKR/X period in ns.

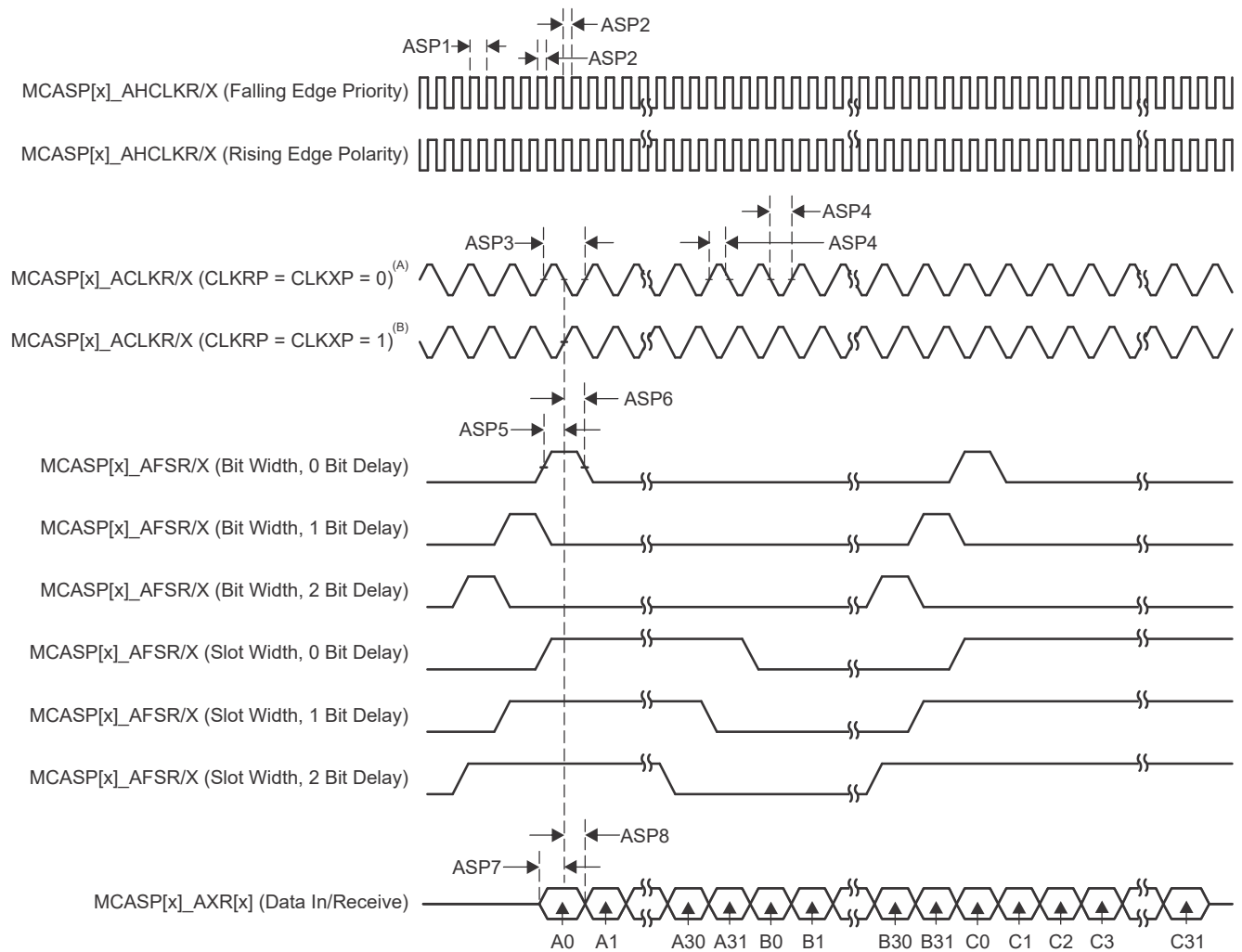

A. For CLKRP = CLKXP = 0, the MCASP transmitter is configured for rising edge (to shift data out) and the MCASP receiver is configured for falling edge (to shift data in).

- B. For CLKRP = CLKXP = 1, the MCASP transmitter is configured for falling edge (to shift data out) and the MCASP receiver is configured for rising edge (to shift data in).

Figure 7-77. MCASP Input Timing

1. x in MCASP[x]_* is 0, 1 or 2

Table 7-48 and Figure 7-78 present switching characteristics over recommended operating conditions for MCASP0 to MCASP11.

Table 7-48. Switching Characteristics Over Recommended Operating Conditions for MCASP

NO.1	PARAMETER	DESCRIPTION	MODE	MIN	MAX	UNIT
ASP9	$t_{c(AHCLKRX)}$	Cycle time, AHCLKR/X		20		ns
ASP10	$t_{w(AHCLKRX)}$	Pulse duration, AHCLKR/X high or low		-2 + 0.5P ²		ns
ASP11	$t_{c(ACLKRX)}$	Cycle time, ACLKR/X		20		ns
ASP12	$t_{w(ACLKRX)}$	Pulse duration, ACLKR/X high or low		-2 + 0.5R ³		ns
ASP13	$t_{d(ACLKRX-AFSRX)}$	Delay time, ACLKR/X transmit edge to AFSR/X output valid	ACLKRX int	0	7.25	ns
			ACLKRX ext in/out	-15.28	12.84	
ASP14	$t_{d(ACLKX-AXR)}$	Delay time, ACLKX transmit edge to AXR output valid	ACLKRX int	0	7.25	ns
			ACLKRX ext in/out	-15.28	12.84	
ASP15	$t_{dis(ACLKX-AXR)}$	Disable time, ACLKX transmit edge to AXR output high impedance	ACLKRX int	0	7.25	ns
			ACLKRX ext in/out	-14.9	14	

1. ACLKR internal: ACLKRCTL.CLKRM=1, PDIR.ACLKR = 1
 ACLKR external input: ACLKRCTL.CLKRM=0, PDIR.ACLKR=0
 ACLKR external output: ACLKRCTL.CLKRM=0, PDIR.ACLKR=1
 ACLKX internal: ACLKXCTL.CLKXM=1, PDIR.ACLKX = 1
 ACLKX external input: ACLKXCTL.CLKXM=0, PDIR.ACLKX=0
 ACLKX external output: ACLKXCTL.CLKXM=0, PDIR.ACLKX=1
2. P = AHCLKR/X period in ns.
3. R = ACLKR/X period in ns.

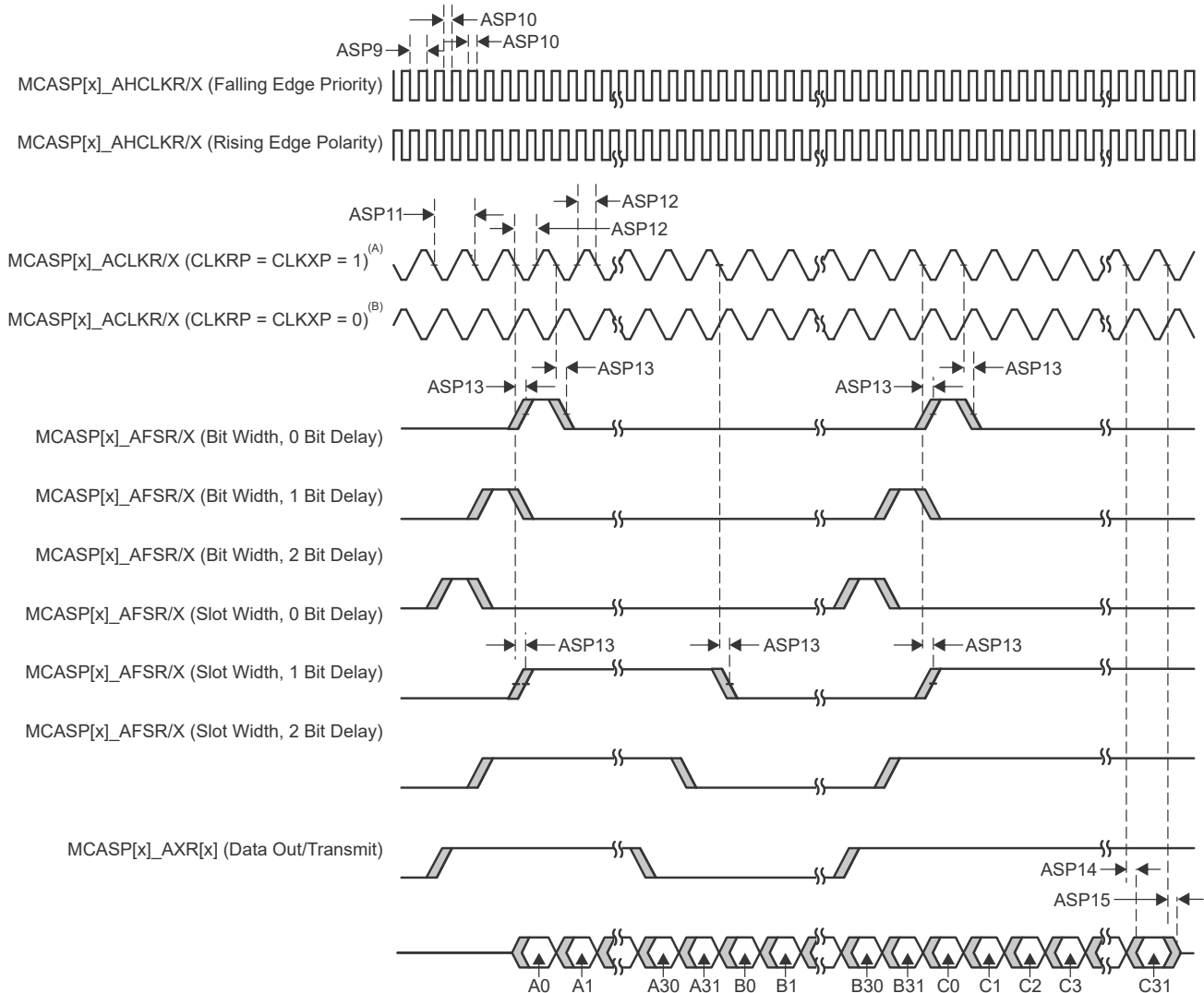

- A. For CLKRP = CLKXP = 1, the MCASP transmitter is configured for falling edge (to shift data out) and the MCASP receiver is configured for rising edge (to shift data in).
- B. For CLKRP = CLKXP = 0, the MCASP transmitter is configured for rising edge (to shift data out) and the MCASP receiver is configured for falling edge (to shift data in).

Figure 7-78. MCASP Output Timing

1. x in MCASP[x]_* is 0, 1 or 2

For more information, see *Multichannel Audio Serial Port (MCASP)* section in *Peripherals* chapter in the device TRM.

7.9.5.15 MCSPI

For more details about features and additional description information on the device Serial Port Interface, see the corresponding sections within [Section 6.3, Signal Descriptions](#) and [Section 8, Detailed Description](#).

For more information, see *Multichannel Serial Peripheral Interface (MCSPI)* section in *Peripherals* chapter in the device TRM.

[Table 7-49](#) represents MCSPI timing conditions.

Table 7-49. MCSPI Timing Conditions

PARAMETER		MIN	MAX	UNIT
Input Conditions				
SR _i	Input slew rate	2	8.5	V/ns
Output Conditions				
C _L	Output load capacitance	CLK	24	pF
		D[x], CSi	12	pF

7.9.5.15.1 MCSPI — Controller Mode

Table 7-50, Figure 7-79, Table 7-51, and Figure 7-80 present timing requirements and switching characteristics for MCSPI – Controller Mode.

Table 7-50. MCSPI Timing Requirements - Controller Mode

see Figure 7-79

PARAMETER		MIN	MAX	UNIT
SM4	t _{su(misoV-spicklV)} Setup time, SPI_D[x] valid before SPI_CLK active edge	2.9		ns
SM5	t _{h(spicklV-misoV)} Hold time, SPI_D[x] valid after SPI_CLK active edge	2		ns

Table 7-51. MCSPI Switching Characteristics - Controller Mode

see Figure 7-80

PARAMETER		MODE	MIN	MAX	UNIT
SM1	t _{c(spickl)}	Cycle time, SPI_CLK	20.8		ns
SM2	t _{w(spicklL)}	Pulse duration, SPI_CLK low	0.5P - 1 ⁽¹⁾		ns
SM3	t _{w(spicklH)}	Pulse duration, SPI_CLK high	0.5P - 1 ⁽¹⁾		ns
SM6	t _{d(spicklV-simoV)}	Delay time, SPI_CLK active edge to SPI_D[x] transition	-2	2	ns
SM7	t _{d(csV-simoV)}	Delay time, SPI_CSi active edge to SPI_D[x] transition	5		ns
SM8	t _{d(csV-spickl)}	PHA = 0 ⁽²⁾	B - 4 ⁽³⁾		ns
		PHA = 1 ⁽²⁾	A - 4 ⁽⁴⁾		ns
SM9	t _{d(spicklV-csV)}	PHA = 0 ⁽²⁾	A - 4 ⁽⁴⁾		ns
		PHA = 1 ⁽²⁾	B - 4 ⁽³⁾		ns

- (1) P = SPI_CLK period in ns
- (2) SPI_CLK phase is programmable with the PHA bit of the MCSPI_CHCONF_0/1/2/3 register
- (3) B = (TCS + .5) * TSPICKLREF, where TCSns a bit field of the MCSPI_CHCONF_0/1/2/3 register and Fratio = Even >= 2.
- (4) When P = 20.8 ns, A = (TCS + 1) * TSPICKLREF, where TCSns a bit field of the MCSPI_CHCONF_0/1/2/3 register.
When P > 20.8 ns, A = (TCS + 0.5) * Fratio * TSPICKLREF, where TCSns a bit field of the MCSPI_CHCONF_0/1/2/3 register.

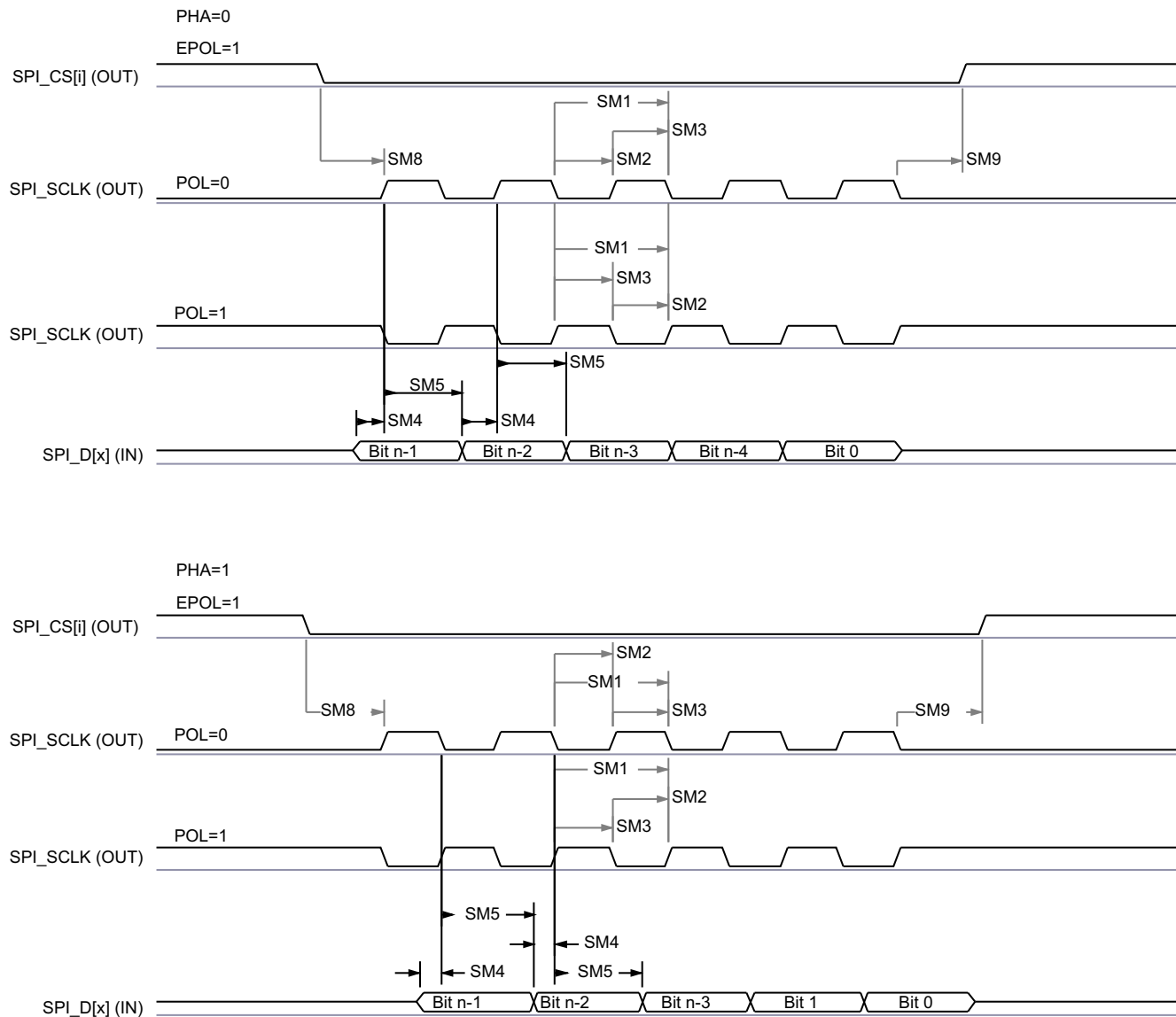

SPRSP08_TIMING_McSPI_02

Figure 7-79. SPI Controller Mode Receive Timing

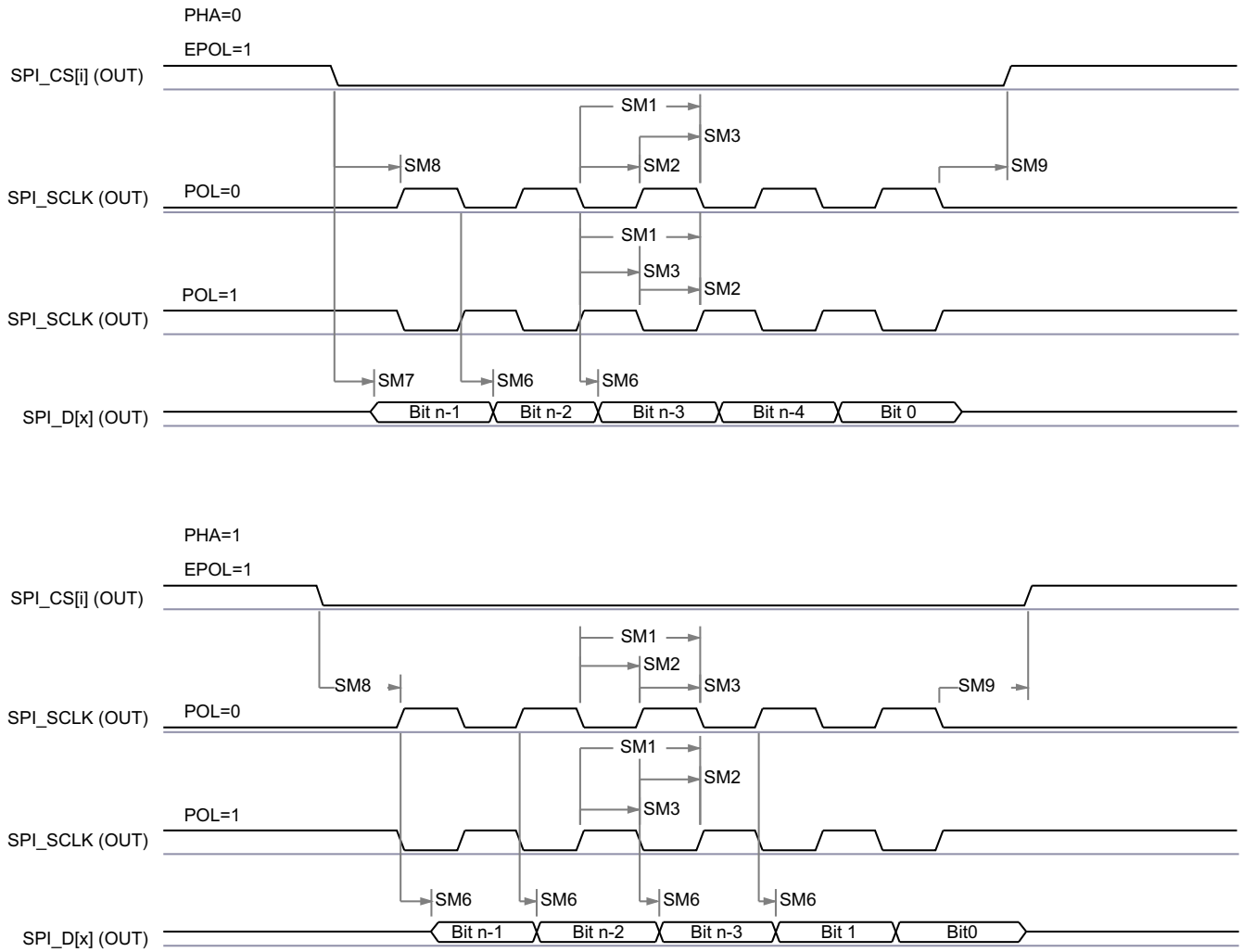

SPRSP08_TIMING_McSPI_01

Figure 7-80. MCSPI Controller Mode Transmit Timing

7.9.5.15.2 MCSPI — Peripheral Mode

Table 7-52, Figure 7-81, Table 7-53, and Figure 7-82 present timing requirements and switching characteristics for MCSPI – Peripheral Mode.

Table 7-52. MCSPI Timing Requirements - Peripheral Mode

PARAMETER			MIN	MAX	UNIT
SS1	$t_{c(\text{spiclk})}$	Cycle time, SPI_CLK	20.8		ns
SS2	$t_{w(\text{spiclkL})}$	Pulse duration, SPI_CLK low	0.45P ⁽¹⁾		ns
SS3	$t_{w(\text{spiclkH})}$	Pulse duration, SPI_CLK high	0.45P ⁽¹⁾		ns
SS4	$t_{su(\text{simoV-spiclkV})}$	Setup time, SPI_D[x] valid before SPI_CLK active edge	5		ns
SS5	$t_{h(\text{spiclkV-simoV})}$	Hold time, SPI_D[x] valid after SPI_CLK active edge	5		ns
SS8	$t_{su(\text{csV-spiclkV})}$	Setup time, SPI_CSi valid before SPI_CLK first edge	5		ns
SS9	$t_{h(\text{spiclkV-csV})}$	Hold time, SPI_CSi valid after SPI_CLK last edge	5		ns

Table 7-53. MCSPI Switching Characteristics - Peripheral Mode

PARAMETER			MIN	MAX	UNIT
SS6	$t_{d(\text{spiclkV-somiV})}$	Delay time, SPI_CLK active edge to SPI_D[x] transition	2	17.12	ns
SS7	$t_{sk(\text{csV-somiV})}$	Delay time, SPI_CSi active edge to SPI_D[x] transition	20.95		ns

(1) P = SPI_CLK period in ns.

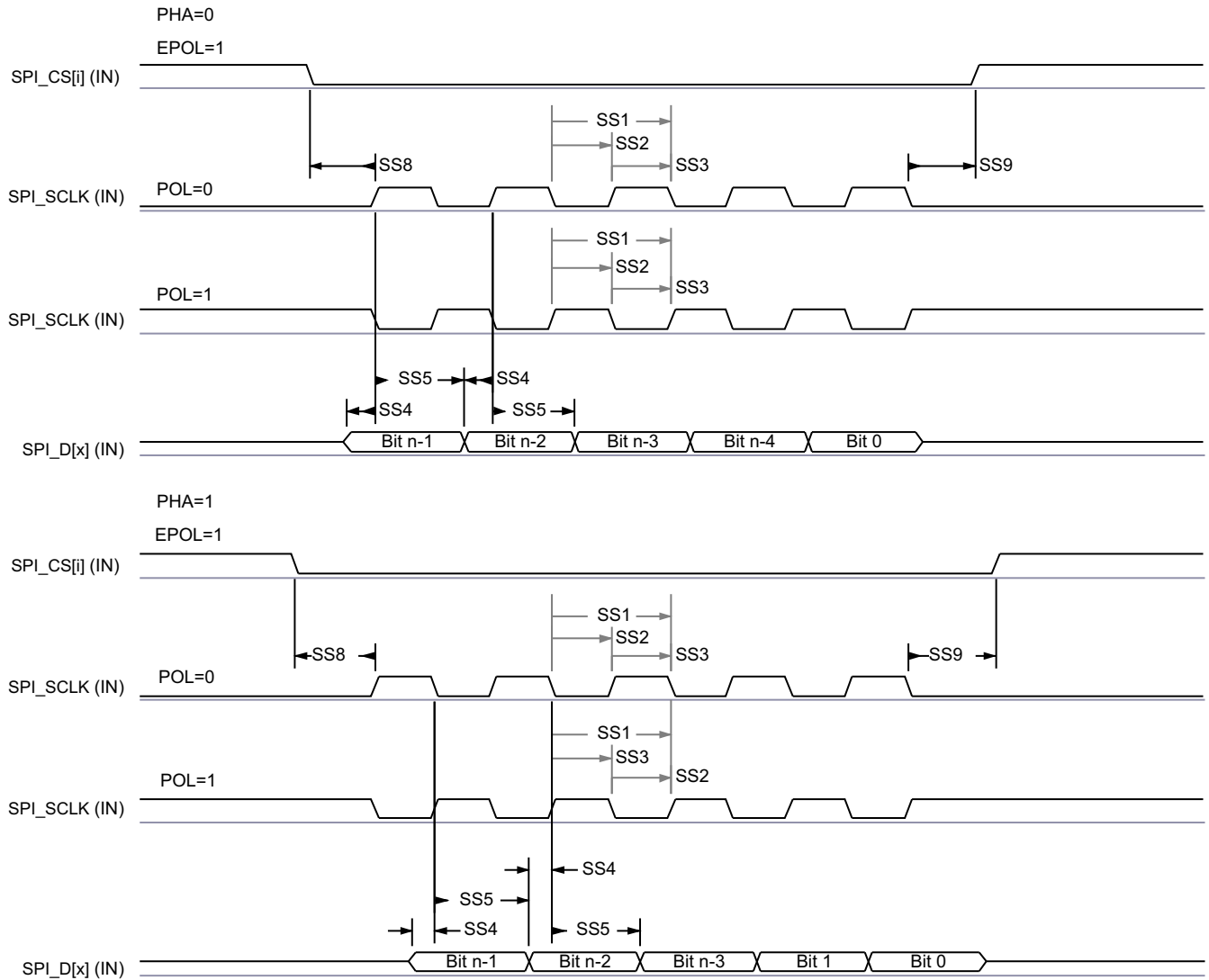

SPRSP08_TIMING_McSPI_04

Figure 7-81. SPI Peripheral Mode Receive Timing

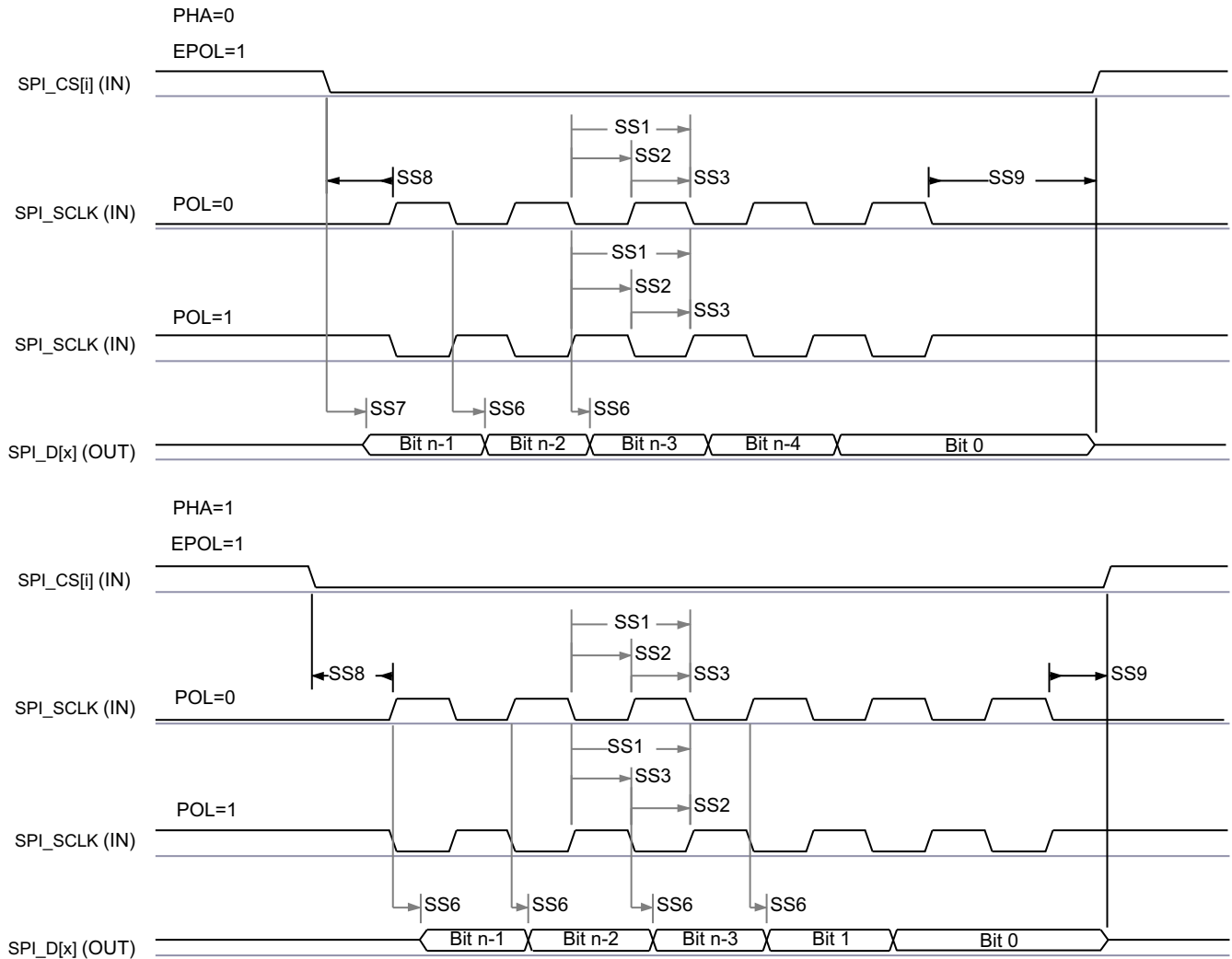

SPRSP08_TIMING_McSPI_03

Figure 7-82. MCSPI Peripheral Mode Transmit Timing

For more information, see *Multichannel Serial Peripheral Interface (MCSPi)* section in *Peripherals* chapter in the device TRM.

7.9.5.16 eMMC/SD/SDIO

The MMCSD Host Controller provides an interface to eMMC 5.1 (embedded MultiMedia Card), SD 4.10 (Secure Digital), and SDIO 4.0 (Secure Digital IO) devices. The MMCSD Host Controller deals with MMC/SD/SDIO protocol at transmission level, data packing, adding cyclic redundancy checks (CRCs), start/end bit insertion, and checking for syntactical correctness.

For more details about features and additional description information on the device Multi Media Card, see the corresponding sections within [Section 6.3, Signal Descriptions](#) and [Section 8, Detailed Description](#).

Note

MMC modes require software configuration of the delay settings, as shown in [Table 7-54](#) and [Table 7-64](#).

Tuning algorithm should be implemented to meet input setup/hold time requirements for SDR50, DDR50 (only on MMCSD1), SDR104, HS200 and HS400 modes.

7.9.5.16.1 MMCSD0 - eMMC Interface

MMCSD0 interface is compliant with the JEDEC eMMC electrical standard v5.1 (JESD84-B51) and it supports the following eMMC applications:

- Default speed
- High speed SDR
- High speed DDR
- High speed HS200
- High speed HS400

Table 7-54 presents the required DLL software configuration settings for MMC0 timing modes.

Table 7-54. MMC0 DLL Delay Mapping for All Timing Modes

REGISTER NAME		MMCSD0_SS_PHY_CTRL_4_REG					MMCSD0_SS_PHY_CTRL_5_REG		
BIT FIELD		[31:24]	[20]	[15:12]	[8]	[4:0]	[17:16]	[10:8]	[2:0]
BIT FIELD NAME		STRBSEL	OTAPDLYENA	OTAPDLYSEL	ITAPDLYENA	ITAPDLYSEL	SELDLYTXCLK SELDLYRXCLK	FRQSEL	CLKBUFSEL
MODE	DESCRIPTION	STROBE DELAY	OUTPUT DELAY ENABLE	OUTPUT DELAY VALUE	INPUT DELAY ENABLE	INPUT DELAY VALUE	DLL/ DELAY CHAIN SELECT	DLL REF FREQUENCY	DELAY BUFFER DURATION
Legacy SDR	8-bit PHY operating 1.8 V, 25 MHz	0x0	0x0	NA	0x1	0x10	0x1	0x0	0x7
High Speed SDR	8-bit PHY operating 1.8 V, 50 MHz	0x0	0x0	NA	0x1	0xA	0x1	0x0	0x7
High Speed DDR	8-bit PHY operating 1.8 V, 50 MHz	0x0	0x1	0x6	0x1	0x3	0x0	0x4	0x7
HS200	8-bit PHY operating 1.8 V, 200 MHz	0x0	0x1	0x8	0x1	Tuning	0x0	0x0	0x7
HS400	8-bit PHY operating 1.8 V, 200 MHz	0x77	0x1	0x5	0x1	Tuning	0x0	0x0	0x7

Table 7-55 represents MMCSD0 timing conditions.

Table 7-55. MMCSD0 Timing Conditions

PARAMETER		MIN	MAX	UNIT	
INPUT CONDITIONS					
SR _i	Input slew rate	Legacy SDR	0.05	1.24	V/ns
		High Speed SDR	0.3	1.65	V/ns
		High Speed DDR (CMD) [DDR52]	0.3	1.65	V/ns
		High Speed DDR (DAT[7:0]) [DDR52]	0.3	1.65	V/ns
OUTPUT CONDITIONS					
C _L	Output load capacitance	Legacy SDR	1	18	pF
		High Speed SDR	1	18	pF
		High Speed DDR	1	18	pF
		HS200	1	12	pF
		HS400	1	6	pF
PCB CONNECTIVITY REQUIREMENTS					
t _d (Trace Delay)	Propagation delay of each trace	All modes	134	756	ps
t _d (Trace Mismatch Delay)	Propagation delay mismatch across all traces	Legacy SDR, High Speed SDR		100	ps
		High Speed DDR, HS200, HS400		8	ps

7.9.5.16.1.1 Legacy SDR Mode

Table 7-56 and Table 7-57 present Timing requirements and Switching characteristics in MMCSD0 - Legacy SDR Mode (see Figure 7-83 and Figure 7-84).

Table 7-56. MMCSD0 Timing Requirements - Legacy SDR Mode

NO.	PARAMETER	DESCRIPTION	MIN	MAX	UNIT
LSDR1	$t_{su(cmdV-clkH)}$	Setup time, MMC0_CMD valid before MMC0_CLK rising edge	2.5		ns
LSDR2	$t_{h(clkH-cmdV)}$	Hold time, MMC0_CMD valid after MMC0_CLK rising edge	6.5		ns
LSDR3	$t_{su(dV-clkH)}$	Setup time, MMC0_DAT[7:0] valid before MMC0_CLK rising edge	2.5		ns
LSDR4	$t_{h(clkH-dV)}$	Hold time, MMC0_DAT[7:0] valid after MMC0_CLK rising edge	6.5		ns

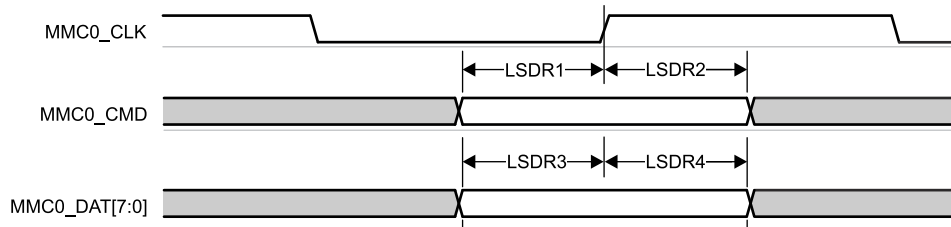

Figure 7-83. MMCSD0 - Legacy SDR - Receive Mode

Table 7-57. MMCSD0 Switching Characteristics - Legacy SDR Mode

NO.	PARAMETER	DESCRIPTION	MIN	MAX	UNIT
	$f_{op(clk)}$	Operating frequency, MMC0_CLK		25	MHz
LSDR5	$t_{c(clk)}$	Cycle time, MMC0_CLK	40		ns
LSDR6	$t_{w(clkH)}$	Pulse duration, MMC0_CLK high	18.7		ns
LSDR7	$t_{w(clkL)}$	Pulse duration, MMC0_CLK low	18.7		ns
LSDR8	$t_{d(clkL-cmdV)}$	Delay time, MMC0_CLK falling edge to MMC0_CMD transition	-3.2	3.8	ns
LSDR9	$t_{d(clkL-dV)}$	Delay time, MMC0_CLK falling edge to MMC0_DAT[7:0] transition	-3.2	3.8	ns

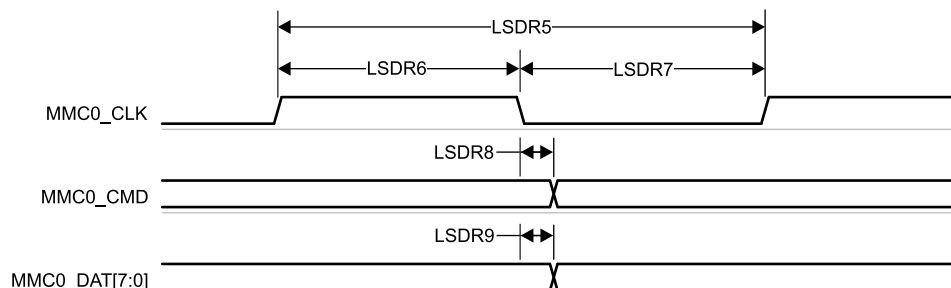

Figure 7-84. MMC0 - Legacy SDR - Transmit Mode

7.9.5.16.1.2 High Speed SDR Mode

Table 7-58 and Table 7-59 present Timing requirements and Switching characteristics for MMCSD0 – High Speed SDR Mode (see Figure 7-85 and Figure 7-86).

Table 7-58. MMCSD0 Timing Requirements - High Speed SDR Mode

NO.	PARAMETER	DESCRIPTION	MIN	MAX	UNIT
HSSDR1	$t_{su(cmdV-clkH)}$	Setup time, MMC0_CMD valid before MMC0_CLK rising edge	2.99		ns
HSSDR2	$t_{h(clkH-cmdV)}$	Hold time, MMC0_CMD valid after MMC0_CLK rising edge	2.67		ns
HSSDR3	$t_{su(dV-clkH)}$	Setup time, MMC0_DAT[7:0] valid before MMC0_CLK rising edge	2.99		ns
HSSDR4	$t_{h(clkH-dV)}$	Hold time, MMC0_DAT[7:0] valid after MMC0_CLK rising edge	2.67		ns

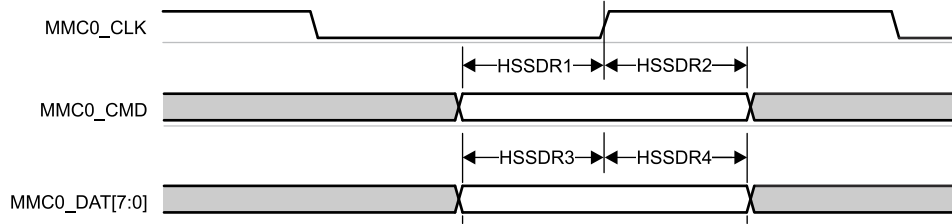

Figure 7-85. MMCSD0 – High Speed SDR Mode – Receive Mode

Table 7-59. MMCSD0 Switching Characteristics - High Speed SDR Mode

NO.	PARAMETER	DESCRIPTION	MIN	MAX	UNIT
	$f_{op}(clk)$	Operating frequency, MMC0_CLK		50	MHz
HSSDR5	$t_{c}(clk)$	Cycle time, MMC0_CLK	20		ns
HSSDR6	$t_{w}(clkH)$	Pulse duration, MMC0_CLK high	9.2		ns
HSSDR7	$t_{w}(clkL)$	Pulse duration, MMC0_CLK low	9.2		ns
HSSDR8	$t_{d}(clkL-cmdV)$	Delay time, MMC0_CLK falling edge to MMC0_CMD transition	-3.2	3.8	ns
HSSDR9	$t_{d}(clkL-dV)$	Delay time, MMC0_CLK falling edge to MMC0_DAT[7:0] transition	-3.2	3.8	ns

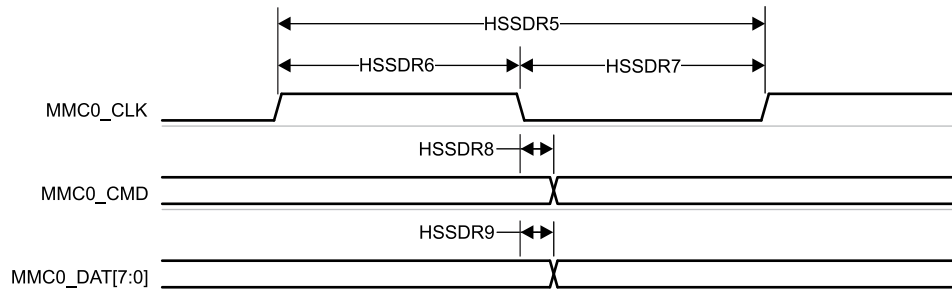

Figure 7-86. MMCSD0 – High Speed SDR Mode – Transmit Mode

7.9.5.16.1.3 High Speed DDR Mode

Table 7-60 and Table 7-61 present Timing requirements and Switching characteristics for MMCSD0 – High Speed DDR Mode (see Figure 7-87 and Figure 7-88).

Table 7-60. MMCSD0 Timing Requirements - High Speed DDR Mode

NO.	PARAMETER	DESCRIPTION	MIN	MAX	UNIT
HSDDR1	$t_{su}(cmdV-clkH)$	Setup time, MMC0_CMD valid before MMC0_CLK rising edge	2.5		ns
HSDDR2	$t_{h}(clkH-cmdV)$	Hold time, MMC0_CMD valid after MMC0_CLK rising edge	2.67		ns
HSDDR3	$t_{su}(dV-clkV)$	Setup time, MMC0_DAT[7:0] valid before MMC0_CLK transition	0.83		ns
HSDDR4	$t_{h}(clkV-dV)$	Hold time, MMC0_DAT[7:0] valid after MMC0_CLK transition	1.76		ns

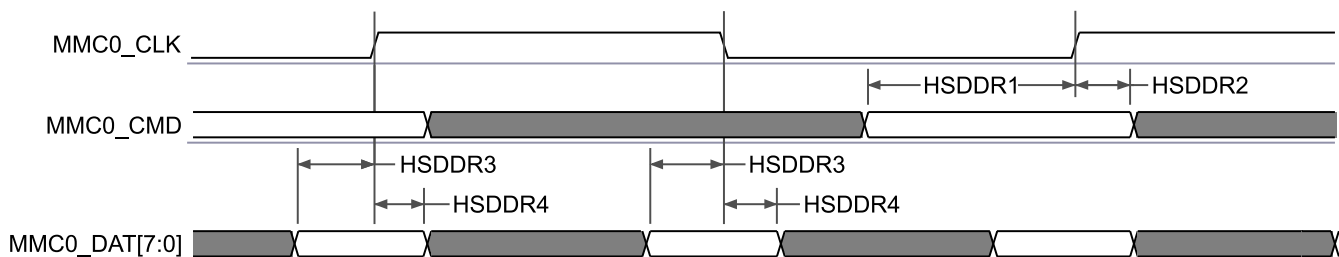

Figure 7-87. MMCSD0 – High Speed DDR Mode – Receive Mode

Table 7-61. MMCSD0 Switching Characteristics - High Speed DDR Mode

NO.	PARAMETER	DESCRIPTION	MIN	MAX	UNIT
	$f_{op}(clk)$	Operating frequency, MMC0_CLK		50	MHz
HSDDR5	$t_{c}(clk)$	Cycle time, MMC0_CLK	20		ns
HSDDR6	$t_{w}(clkH)$	Pulse duration, MMC0_CLK high	9.2		ns
HSDDR7	$t_{w}(clkL)$	Pulse duration, MMC0_CLK low	9.2		ns
HSDDR8	$t_{d}(clkH-cmdV)$	Delay time, MMC0_CLK rising edge to MMC0_CMD transition	3.31	9.8	ns
HSDDR9	$t_{d}(clkV-dV)$	Delay time, MMC0_CLK transition to MMC0_DAT[7:0] transition	2.81	6.94	ns

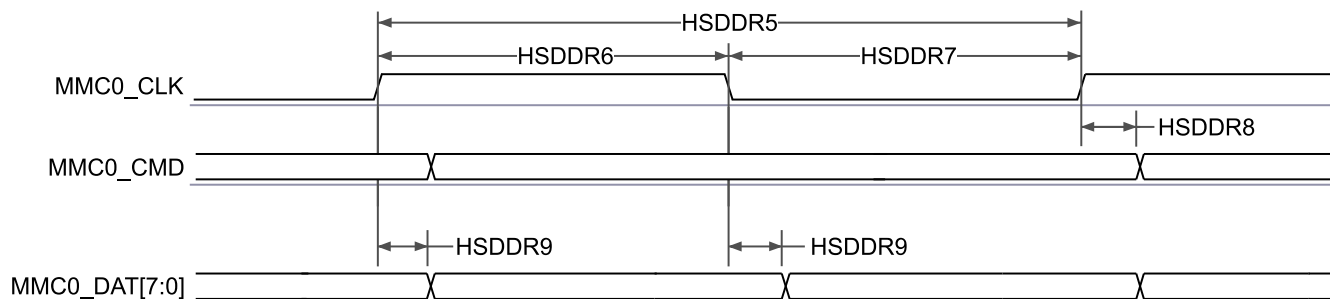

Figure 7-88. MMCSD0 – High Speed DDR Mode – Transmit Mode

7.9.5.16.1.4 HS200 Mode

Table 7-62 presents Switching characteristics for MMCSD0 – HS200 Mode (see Figure 7-89).

Table 7-62. MMCSD0 Switching Characteristics - HS200 Mode

NO.	PARAMETER	DESCRIPTION	MIN	MAX	UNIT
	$f_{op}(clk)$	Operating frequency, MMC0_CLK		200	MHz
HS2005	$t_{c}(clk)$	Cycle time, MMC0_CLK	5		ns
HS2006	$t_{w}(clkH)$	Pulse duration, MMC0_CLK high	2.08		ns
HS2007	$t_{w}(clkL)$	Pulse duration, MMC0_CLK low	2.08		ns
HS2008	$t_{d}(clkL-cmdV)$	Delay time, MMC0_CLK rising edge to MMC0_CMD transition	0.99	3.28	ns
HS2009	$t_{d}(clkL-dV)$	Delay time, MMC0_CLK rising edge to MMC0_DAT[7:0] transition	0.99	3.28	ns

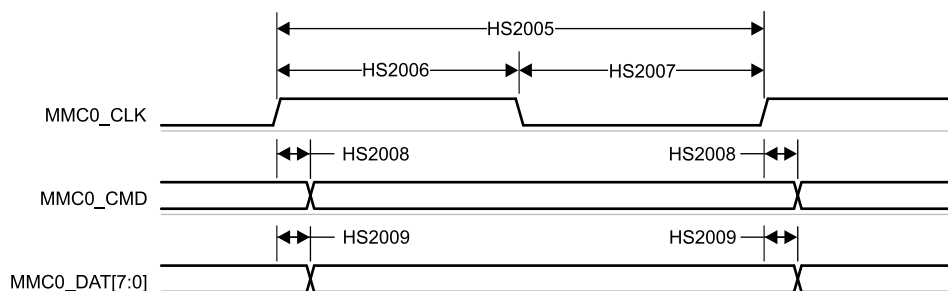

Figure 7-89. MMCSD0 – HS200 Mode – Transmit Mode

7.9.5.16.1.5 HS400 Mode

Table 7-63 presents Switching characteristics for MMCSD0 – HS400 Mode (see Figure 7-90).

Table 7-63. MMCSD0 Switching Characteristics - HS400 Mode

NO.	PARAMETER	DESCRIPTION	MIN	MAX	UNIT
	$f_{op}(clk)$	Operating frequency, MMC0_CLK		200	MHz
HS4005	$t_{c}(clk)$	Cycle time, MMC0_CLK	5		ns
HS4006	$t_{w}(clkH)$	Pulse duration, MMC0_CLK high	2.08		ns
HS4007	$t_{w}(clkL)$	Pulse duration, MMC0_CLK low	2.08		ns
HS4008	$t_{d}(clkH-cmdV)$	Delay time, MMC0_CLK rising clock edge to MMC0_CMD transition	0.99	3.28	ns
HS4009	$t_{d}(clkV-dV)$	Delay time, MMC0_CLK transition to MMC0_DAT[7:0] transition	0.59	1.84	ns

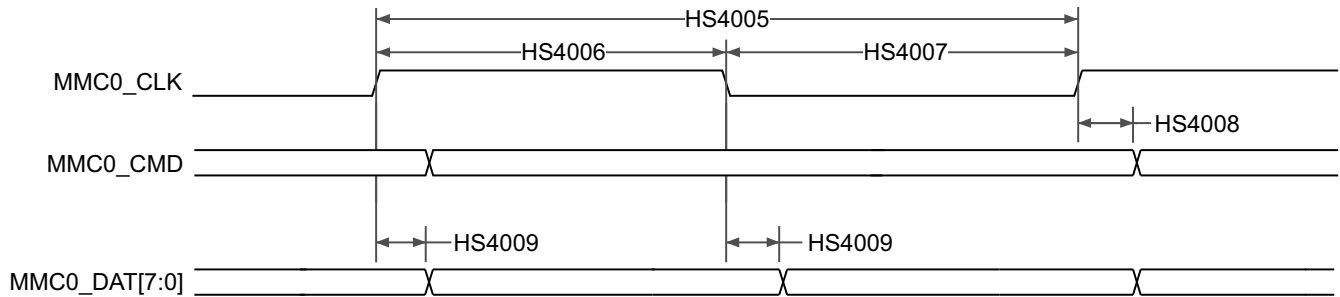

Figure 7-90. MMCSD0 – HS400 Mode – Transmit Mode

7.9.5.16.2 MMCSDi — MMCSD1 — SD/SDIO Interface

Note

The MMCSDi (i = 1) controller is also referred to as MMCi.

MMCSDi interface is compliant with the SD Host Controller Standard Specification 4.10 and SD Physical Layer Specification v3.01 as well as SDIO Specification v3.00 and it supports the following SD Card applications:

- Default speed
- High speed
- UHS-I SDR12
- UHS-I SDR25
- UHS-I SDR50
- UHS-I SDR104
- UHS-I DDR50

Table 7-64 presents the required delay software configuration settings for MMC1 timing modes.

Table 7-64. MMC1 Delay Mapping for All Timing Modes

REGISTER NAME		MMCSD12_SS_PHY_CTRL_4_REG				MMCSD12_SS_PHY_CTRL_5_REG
BIT FIELD		[20]	[15:12]	[8]	[4:0]	[2:0]
BIT FIELD NAME		OTAPDLYENA	OTAPDLYSEL	ITAPDLYENA	ITAPDLYSEL	CLKBUFSEL
MODE	DESCRIPTION	DELAY ENABLE	DELAY VALUE	INPUT DELAY ENABLE	INPUT DELAY VALUE	DELAY BUFFER DURATION
Default Speed	4-bit PHY operating 3.3 V, 25 MHz	0x1	0x0	0x0	0x0	0x7
High Speed	4-bit PHY operating 3.3 V, 50 MHz	0x1	0x0	0x0	0x0	0x7
UHS-I SDR12	4-bit PHY operating 1.8 V, 25 MHz	0x1	0xF	0x0	0x0	0x7
UHS-I SDR25	4-bit PHY operating 1.8 V, 50 MHz	0x1	0xF	0x0	0x0	0x7
UHS-I SDR50	4-bit PHY operating 1.8 V, 100 MHz	0x1	0xC	0x1	Tuning	0x7
UHS-I DDR50	4-bit PHY operating 1.8 V, 50 MHz	0x1	0xC	0x1	Tuning	0x7
UHS-I SDR104	4-bit PHY operating 1.8, V 200 MHz	0x1	0x5	0x1	Tuning	0x7

Table 7-65 represents MMCSD1 timing conditions.

Table 7-65. MMCSD1 Timing Conditions

PARAMETER	DESCRIPTION	MODE	MIN	MAX	UNIT
INPUT CONDITIONS					
SR _i	Input slew rate	Default Speed, High Speed	0.69	2.06	V/ns
		UHS-I SDR12, UHS-I SDR25	0.34	1.34	V/ns
OUTPUT CONDITIONS					
C _L	Output load capacitance	All Speed Modes	1	10	pF
PCB CONNECTIVITY REQUIREMENTS					

Table 7-65. MMCSD1 Timing Conditions (continued)

PARAMETER	DESCRIPTION	MODE	MIN	MAX	UNIT
t_d (Trace Delay)	Propagation delay of each trace	Default Speed, High Speed	126	1200	ps
		UHS-I DDR50	255	1134	ps
		All Other Modes	134	1276	ps
t_d (Trace Mismatch Delay)	Propagation delay mismatch across all traces	UHS-I DDR50		20	ps
		UHS-I SDR104		8	ps
		All Other Modes		100	ps

7.9.5.16.2.1 Default speed Mode

Table 7-66 and Table 7-67 present timing requirements and switching characteristics for MMCSDi – Default Speed Mode (see Figure 7-91 and Figure 7-92)

Table 7-66. MMCSD1 Timing Requirements – Default Speed Mode

NO.	PARAMETER	DESCRIPTION	MIN	MAX	UNIT
DS1	$t_{su}(cmdV-clkH)$	Setup time, MMC[x]_CMD valid before MMC[x]_CLK rising edge	2.15		ns
DS2	$t_h(clkH-cmdV)$	Hold time, MMC[x]_CMD valid after MMC[x]_CLK rising edge	4.56		ns
DS3	$t_{su}(dV-clkH)$	Setup time, MMC[x]_DAT[3:0] valid before MMC[x]_CLK rising edge	2.15		ns
DS4	$t_h(clkH-dV)$	Hold time, MMC[x]_DAT[3:0] valid after MMC[x]_CLK rising edge	4.56		ns

1. x = 1 for MMC1

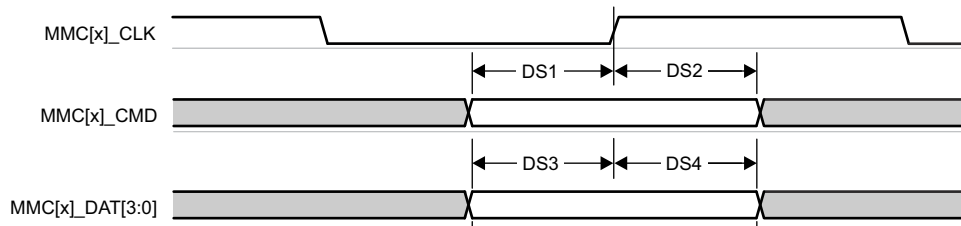

Figure 7-91. MMCSD1 – Default Speed – Receive Mode

Table 7-67. MMCSD1 Switching Characteristics – Default Speed Mode

NO.	PARAMETER	DESCRIPTION	MIN	MAX	UNIT
	$f_{op}(clk)$	Operating frequency, MMC[x]_CLK		25	MHz
DS5	$t_c(clk)$	Cycle time, MMC[x]_CLK	40		ns
DS6	$t_w(clkH)$	Pulse duration, MMC[x]_CLK high	18.7		ns
DS7	$t_w(clkL)$	Pulse duration, MMC[x]_CLK low	18.7		ns
DS8	$t_d(clkL-cmdV)$	Delay time, MMC[x]_CLK falling edge to MMC[x]_CMD transition	-3.53	3.53	ns
DS9	$t_d(clkL-dV)$	Delay time, MMC[x]_CLK falling edge to MMC[x]_DAT[3:0] transition	-3.53	3.53	ns



Figure 7-92. MMCSD1 – Default Speed – Transmit Mode

7.9.5.16.2.2 High Speed Mode

Table 7-68 and Table 7-69 present timing requirements and switching characteristics for MMCSDi – High Speed Mode (see Figure 7-93 and Figure 7-94).

Table 7-68. MMCSD1 Timing Requirements – High Speed Mode

NO.	PARAMETER	DESCRIPTION	MIN	MAX	UNIT
HS1	$t_{su(cmdV-clkH)}$	Setup time, MMC[x]_CMD valid before MMC[x]_CLK rising edge	2.15		ns
HS2	$t_{h(clkH-cmdV)}$	Hold time, MMC[x]_CMD valid after MMC[x]_CLK rising edge	2.26		ns
HS3	$t_{su(dV-clkH)}$	Setup time, MMC[x]_DAT[3:0] valid before MMC[x]_CLK rising edge	2.15		ns
HS4	$t_{h(clkH-dV)}$	Hold time, MMC[x]_DAT[3:0] valid after MMC[x]_CLK rising edge	2.26		ns

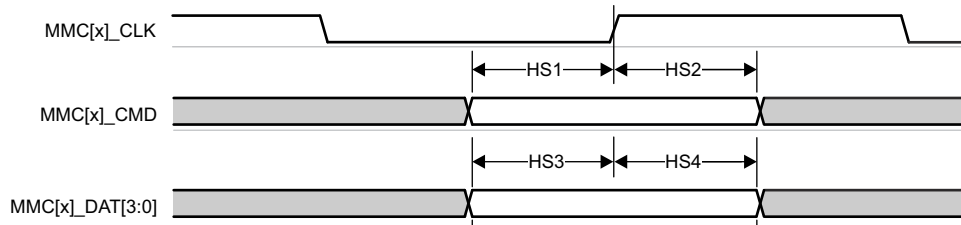

Figure 7-93. MMCSD1 – High Speed – Receive Mode

Table 7-69. MMCSD1 Switching Characteristics – High Speed Mode

NO.	PARAMETER	DESCRIPTION	MIN	MAX	UNIT
	$f_{op(clk)}$	Operating frequency, MMC[x]_CLK		50	MHz
HS5	$t_{c(clk)}$	Cycle time, MMC[x]_CLK	20		ns
HS6	$t_{w(clkH)}$	Pulse duration, MMC[x]_CLK high	9.2		ns
HS7	$t_{w(clkL)}$	Pulse duration, MMC[x]_CLK low	9.2		ns
HS8	$t_{d(clkL-cmdV)}$	Delay time, MMC[x]_CLK falling edge to MMC[x]_CMD transition	-2.07	2.07	ns
HS9	$t_{d(clkL-dV)}$	Delay time, MMC[x]_CLK falling edge to MMC[x]_DAT[3:0] transition	-2.07	2.07	ns

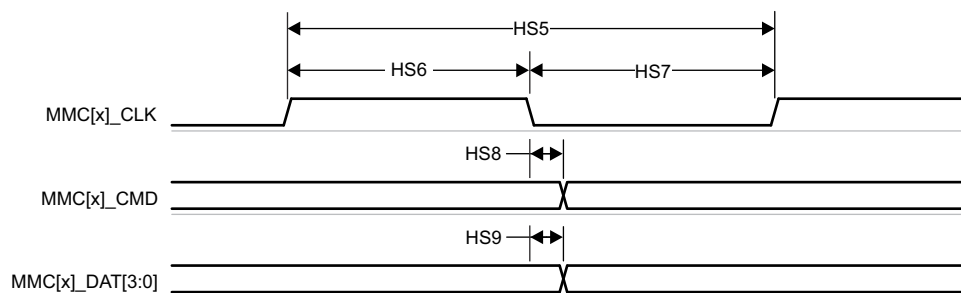

Figure 7-94. MMCSD1 – High Speed – Transmit Mode

7.9.5.16.2.3 UHS-I SDR12 Mode

Table 7-70 and Table 7-71 present timing requirements and switching characteristics for MMCSDi – UHS-I SDR12 Mode (see Figure 7-95 and Figure 7-96).

Table 7-70. MMCSD1 Timing Requirements – UHS-I SDR12 Mode

NO.	PARAMETER	DESCRIPTION	MIN	MAX	UNIT
SDR121	$t_{su(cmdV-clkH)}$	Setup time, MMC[x]_CMD valid before MMC[x]_CLK rising edge	5.46		ns
SDR122	$t_{h(clkH-cmdV)}$	Hold time, MMC[x]_CMD valid after MMC[x]_CLK rising edge	1.67		ns
SDR123	$t_{su(dV-clkH)}$	Setup time, MMC[x]_DAT[3:0] valid before MMC[x]_CLK rising edge	5.46		ns

Table 7-70. MMCSD1 Timing Requirements – UHS-I SDR12 Mode (continued)

NO.	PARAMETER	DESCRIPTION	MIN	MAX	UNIT
SDR124	$t_{h(\text{clkH-dV})}$	Hold time, MMC[x]_DAT[3:0] valid after MMC[x]_CLK rising edge	1.67		ns

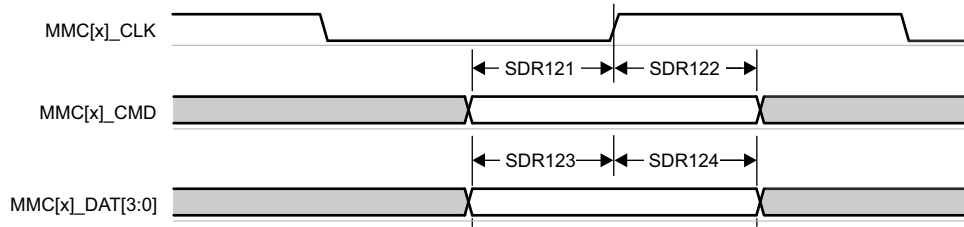

Figure 7-95. MMCSD1 – UHS-I SDR12 – Receive Mode

Table 7-71. MMCSD1 Switching Characteristics – UHS-I SDR12 Mode

NO.	PARAMETER	DESCRIPTION	MIN	MAX	UNIT
	$f_{op(\text{clk})}$	Operating frequency, MMC[x]_CLK		25	MHz
SDR125	$t_{c(\text{clk})}$	Cycle time, MMC[x]_CLK	40		ns
SDR126	$t_{w(\text{clkH})}$	Pulse duration, MMC[x]_CLK high	18.7		ns
SDR127	$t_{w(\text{clkL})}$	Pulse duration, MMC[x]_CLK low	18.7		ns
SDR128	$t_{d(\text{clkH-cmdV})}$	Delay time, MMC[x]_CLK rising edge to MMC[x]_CMD transition	1.2	13.55	ns
SDR129	$t_{d(\text{clkH-dV})}$	Delay time, MMC[x]_CLK rising edge to MMC[x]_DAT[3:0] transition	1.2	13.55	ns

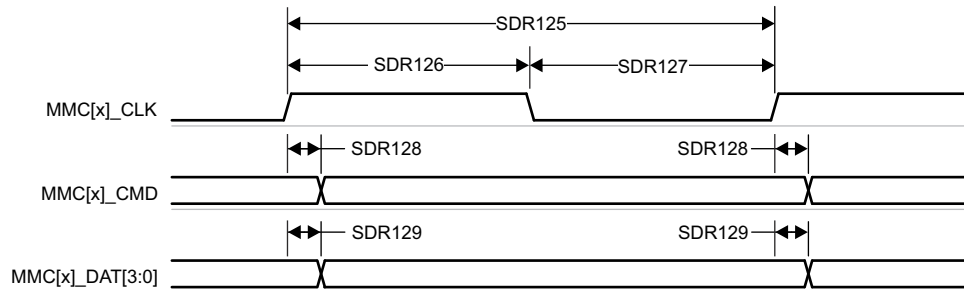

Figure 7-96. MMCSD1 – UHS-I SDR12 – Transmit Mode

7.9.5.16.2.4 UHS-I SDR25 Mode

Table 7-72 and Table 7-73 present timing requirements and switching characteristics for MMCSDi – UHS-I SDR25 Mode (see Figure 7-97 and Figure 7-98).

Table 7-72. MMCSD1 Timing Requirements – UHS-I SDR25 Mode

NO.	PARAMETER	DESCRIPTION	MIN	MAX	UNIT
SDR251	$t_{su(\text{cmdV-clkH})}$	Setup time, MMC[x]_CMD valid before MMC[x]_CLK rising edge	2.1		ns
SDR252	$t_{h(\text{clkH-cmdV})}$	Hold time, MMC[x]_CMD valid after MMC[x]_CLK rising edge	1.67		ns
SDR253	$t_{su(\text{dV-clkH})}$	Setup time, MMC[x]_DAT[3:0] valid before MMC[x]_CLK rising edge	2.1		ns
SDR254	$t_{h(\text{clkH-dV})}$	Hold time, MMC[x]_DAT[3:0] valid after MMC[x]_CLK rising edge	1.67		ns

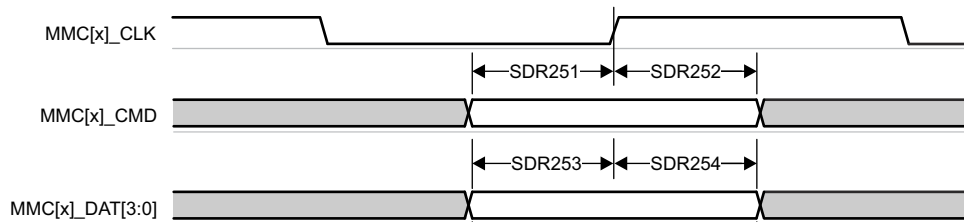

Figure 7-97. MMCSD1 – UHS-I SDR25 – Receive Mode

Table 7-73. MMCSD1 Switching Characteristics – UHS-I SDR25 Mode

NO.	PARAMETER	DESCRIPTION	MIN	MAX	UNIT
	$f_{op}(clk)$	Operating frequency, MMC[x]_CLK		50	MHz
SDR255	$t_{c}(clk)$	Cycle time, MMC[x]_CLK	20		ns
SDR256	$t_{w}(clkH)$	Pulse duration, MMC[x]_CLK high	9.2		ns
SDR257	$t_{w}(clkL)$	Pulse duration, MMC[x]_CLK low	9.2		ns
SDR258	$t_{d}(clkH-cmdV)$	Delay time, MMC[x]_CLK rising edge to MMC[x]_CMD transition	2.4	9.37	ns
SDR259	$t_{d}(clkH-dV)$	Delay time, MMC[x]_CLK rising edge to MMC[x]_DAT[3:0] transition	2.4	9.37	ns

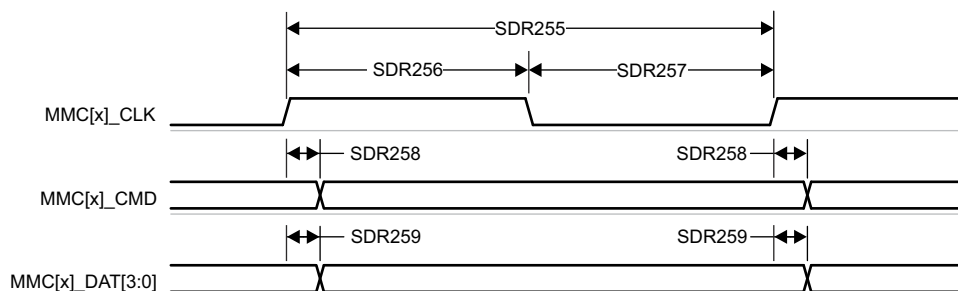

Figure 7-98. MMCSD1 – UHS-I SDR25 – Transmit Mode

7.9.5.16.2.5 UHS-I SDR50 Mode

Table 7-74 presents timing requirements and switching characteristics for MMCSDi – UHS-I SDR50 Mode (see and Figure 7-99).

Table 7-74. MMCSD1 Switching Characteristics – UHS-I SDR50 Mode

NO.	PARAMETER	DESCRIPTION	MIN	MAX	UNIT
	$f_{op}(clk)$	Operating frequency, MMC[x]_CLK		100	MHz
SDR505	$t_{c}(clk)$	Cycle time, MMC[x]_CLK	10		ns
SDR506	$t_{w}(clkH)$	Pulse duration, MMC[x]_CLK high	4.45		ns
SDR507	$t_{w}(clkL)$	Pulse duration, MMC[x]_CLK low	4.45		ns
SDR508	$t_{d}(clkH-cmdV)$	Delay time, MMC[x]_CLK rising edge to MMC[x]_CMD transition	1.2	6.35	ns
SDR509	$t_{d}(clkH-dV)$	Delay time, MMC[x]_CLK rising edge to MMC[x]_DAT[3:0] transition	1.2	6.35	ns

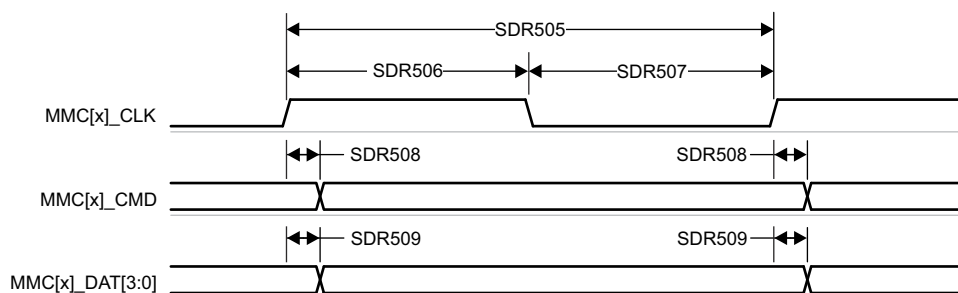

Figure 7-99. MMCSD1 – UHS-I SDR50 – Transmit Mode

7.9.5.16.2.6 UHS-I DDR50 Mode

Table 7-75 present switching characteristics for MMCSDi – UHS-I DDR50 Mode (see Figure 7-100).

Table 7-75. MMCSD1 Switching Characteristics – UHS-I DDR50 Mode

NO.	PARAMETER	DESCRIPTION	MIN	MAX	UNIT
	$f_{op}(clk)$	Operating frequency, MMC[x]_CLK		50	MHz
DDR505	$t_{c}(clk)$	Cycle time, MMC[x]_CLK	20		ns
DDR506	$t_{w}(clkH)$	Pulse duration, MMC[x]_CLK high	9.2		ns

Table 7-75. MMCSD1 Switching Characteristics – UHS-I DDR50 Mode (continued)

NO.	PARAMETER	DESCRIPTION	MIN	MAX	UNIT
DDR507	$t_{w(\text{clkL})}$	Pulse duration, MMC[x]_CLK low	9.2		ns
DDR508	$t_{d(\text{clkH-cmdV})}$	Delay time, MMC[x]_CLK rising edge to MMC[x]_CMD transition	1.2	3.46	ns
DDR509	$t_{d(\text{clk-dV})}$	Delay time, MMC[x]_CLK transition to MMC[x]_DAT[3:0] transition	1.2	6.12	ns

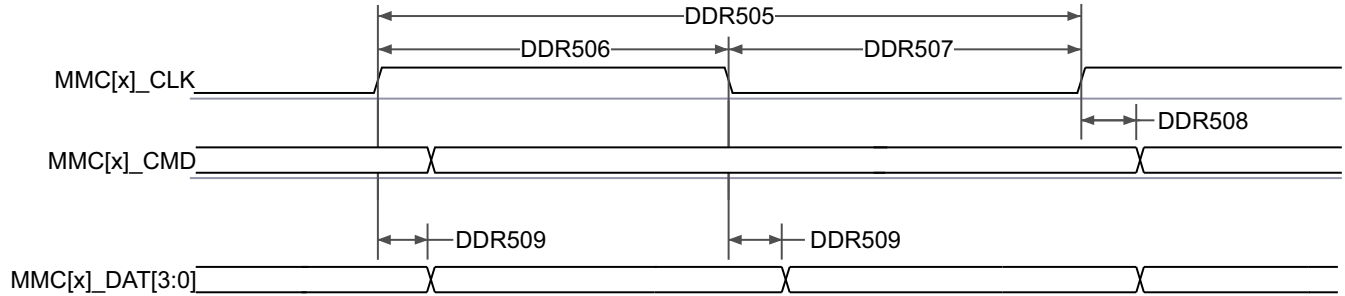

Figure 7-100. MMCSD1 – UHS-I DDR50 – Transmit Mode

7.9.5.16.2.7 UHS-I SDR104 Mode

Table 7-76 presents timing requirements and switching characteristics for MMCSDi – UHS-I SDR104 Mode (see Figure 7-101)

Table 7-76. MMCSD1 Switching Characteristics – UHS-I SDR104 Mode

NO.	PARAMETER	DESCRIPTION	MIN	MAX	UNIT
	$f_{op}(clk)$	Operating frequency, MMC[x]_CLK		200	MHz
SDR1045	$t_{c}(clk)$	Cycle time, MMC[x]_CLK	5		ns
SDR1046	$t_{w}(clkH)$	Pulse duration, MMC[x]_CLK high	2.12		ns
SDR1047	$t_{w}(clkL)$	Pulse duration, MMC[x]_CLK low	2.12		ns
SDR1048	$t_{d}(clkH-cmdV)$	Delay time, MMC[x]_CLK rising edge to MMC[x]_CMD transition	2.12	3.2	ns
SDR1049	$t_{d}(clkH-dV)$	Delay time, MMC[x]_CLK rising edge to MMC[x]_DAT[3:0] transition	2.12	3.2	ns



Figure 7-101. MMCSD1 – UHS-I SDR104 – Transmit Mode

7.9.5.17 NAVSS

Table 7-77 represents CPTS timing conditions.

Table 7-77. CPTS Timing Conditions

PARAMETER	DESCRIPTION	MIN	MAX	UNIT
Input Conditions				
t_{SR}	Input slew rate	0.5	5	V/ns
Output Conditions				
C_{LOAD}	Output load capacitance	2	10	pF

Section 7.9.5.17.1, Section 7.9.5.17.2, Figure 7-102, and Figure 7-103 present timing requirement and switching characteristics of the CPTS interface.

7.9.5.17.1 Timing Requirements for CPTS Input

NO.	PARAMETER	DESCRIPTION	MIN	MAX	UNIT
T1	$t_{w}(HWn_TS_PUSHH)$	HWn_TS_PUSH Pulse duration, high	$2.1 + 12P^{(1)}$		ns
T2	$t_{w}(HWn_TS_PUSHL)$	HWn_TS_PUSH pulse duration, low	$2.1 + 12P^{(1)}$		ns
T3	$t_{c}(RFT_CLK)$	RFT_CLK cycle time	5	8	ns
T4	$t_{w}(RFT_CLKH)$	RFT_CLK pulse duration, high	$0.45 \times t_{c}(RFT_CLK)$		ns
T5	$t_{w}(RFT_CLKL)$	RFT_CLK pulse duration, low	$0.45 \times t_{c}(RFT_CLK)$		ns

(1) P = functional clock period in ns.

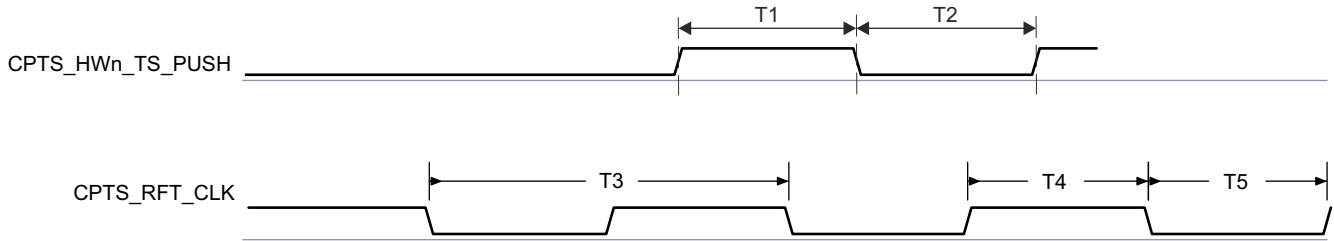

Figure 7-102. CPTS Input Timing

7.9.5.17.2 Switching Characteristics for CPTS Output

NO.	PARAMETER	DESCRIPTION	MIN	MAX	UNIT
T6	$t_w(TS_COMPH)$	NAVSS-CPTS TS_COMP, high	$-2.1+36P^{(1)}$		ns
T7	$t_w(TS_COMPL)$	NAVSS-CPTS TS_COMP, low	$-2.1+36P^{(1)}$		ns
T8	$t_w(TS_COMPH)$	CPSW-CPTS TS_COMP, high	$-2.1+36P^{(1)}$		ns
T9	$t_w(TS_COMPL)$	CPSW-CPTS TS_COMP, low	$-2.1+36P^{(1)}$		ns
T10	$t_w(TS_SYNCH)$	NAVSS-CPTS TS_SYNC, high	$-2.1+36P^{(1)}$		ns
T11	$t_w(TS_SYNCL)$	NAVSS-CPTS TS_SYNC, low	$-2.1+36P^{(1)}$		ns
T12.1	$t_w(TS_SYNCH)$	CPSW-CPTS TS_SYNC, high	$-2.1+36P^{(1)}$		ns
T13	$t_w(TS_SYNCL)$	CPSW-CPTS TS_SYNC, low	$-2.1+36P^{(1)}$		ns
T14	$t_w(SYNC_OUTH)$	TS_SYNC sourcing SYNCn_OUT, high	$-2.1+36P^{(1)}$		ns
T15	$t_w(SYNC_OUTL)$	TS_SYNC sourcing SYNCn_OUT, low	$-2.1+36P^{(1)}$		ns
T16	$t_w(SYNC_OUTH)$	GENF sourcing SYNCn_OUT, high	$-2.1+5P^{(1)}$		ns
T17	$t_w(SYNC_OUTL)$	GENF sourcing SYNCn_OUT, low	$-2.1+5P^{(1)}$		ns

(1) P = functional clock period in ns.

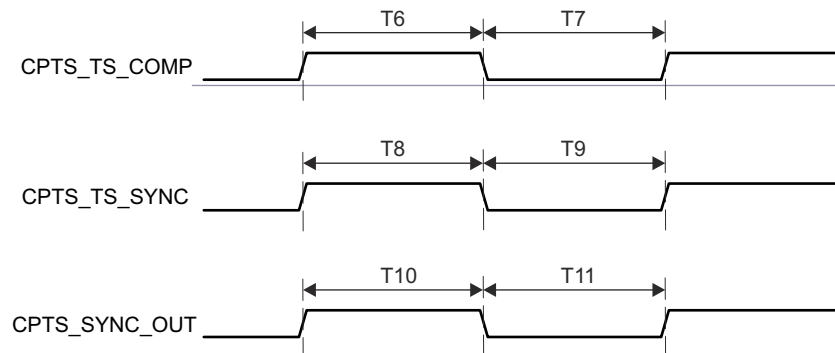

Figure 7-103. CPTS Output Switching Characteristics

For more information, see *Navigator Subsystem (NAVSS)* section in *Data Movement Architecture (DMA)* chapter in the device TRM.

7.9.5.18 OSPI

For more details about features and additional description information on the device Octal Serial Peripheral Interface, see the corresponding sections within [Section 6.3, Signal Descriptions](#) and [Section 8, Detailed Description](#).

[Table 7-78](#) represents OSPI timing conditions.

Table 7-78. OSPIx Timing Conditions

PARAMETER	MODE	MIN	MAX	UNIT
INPUT CONDITIONS				

Table 7-78. OSPIx Timing Conditions (continued)

PARAMETER		MODE	MIN	MAX	UNIT
SR _I	Input slew rate		1	6	V/ns
OUTPUT CONDITIONS					
C _L	Output load capacitance		3	10	pF
PCB CONNECTIVITY REQUIREMENTS					
t _d (Trace Delay)	Propagation delay of OSPI0_CLK traces	No Loopback Internal PHY Loopback Internal Pad Loopback		450	ps
	Propagation delay of OSPI0_LBCLKO traces	External Board Loopback	2L ⁽¹⁾ - 30	2L ⁽¹⁾ + 30	ps
	Propagation delay of OSPI0_DQS traces	DQS	L ⁽¹⁾ - 30	L ⁽¹⁾ + 30	ps
t _d (Trace Mismatch Delay)	Propagation delay mismatch of OSPIx_D[7:0] and OSPIx_CS _n [3:0] relative to OSPIx_CLK	All modes		60	ps

(1) L = Propagation delay of OSPIx_CLK trace

For more information, see *Octal Serial Peripheral Interface (OSPI)* section in *Peripherals* chapter in the device TRM.

7.9.5.18.1 OSPI With Data Training

7.9.5.18.1.1 OSPI Switching Characteristics – Data Training

PARAMETER	DESCRIPTION	MODE	MIN	MAX	UNIT
t _c (CLK)	Cycle time, CLK	DDR, 1.8V	6.02		ns
		DDR, 3.3V	7.52		ns
t _c (CLK)	Cycle time, CLK	SDR, 1.8V	6.02		ns
		SDR, 3.3V	7.52		ns

7.9.5.18.2 OSPI Without Data Training

Note

The I/O Timings provided in this section are only applicable when data training is not implemented. Additionally, the I/O Timings are valid only for some OSPI usage modes when the corresponding DLL Delays are configured as described in [Table 7-79](#) found in this section.

[Section 7.9.5.18.2.1](#), [Section 7.9.5.18.2.2](#), [Figure 7-104](#), and [Figure 7-105](#) present switching characteristics for OSPI DDR and SDR Mode.

7.9.5.18.2.1 OSPI Switching Characteristics – DDR Mode

NO. (1)	PARAMETER	DESCRIPTION	MODE	MIN	MAX	UNIT
O1	t _c (CLK)	Cycle time, CLK	1.8V	19		ns
			3.3V	19		ns
O2	t _w (CLKL)	Pulse duration, CLK low		-0.3+0.475*P (2)		ns
O3	t _w (CLKH)	Pulse duration, CLK high		-0.3+0.475*P (2)		ns
O4	t _d (CLK-CS _n)	Delay time, CS _n [3:0] active edge to CLK rising edge	1.8V, OSPI0 DDR TX; 1.8V, OSPI1 DDR TX	-7-0.475 * P – 0.975 * N * R (3) (4) (5)	0.525 * P + 1.025 * M * R + 1 (3) (4) (5)	ns
			3.3V, OSPI0 DDR TX; 3.3V, OSPI1 DDR TX	-7-0.475 * P – 0.975 * N * R (3) (4) (5)	0.525 * P + 1.025 * M * R + 1 (3) (4) (5)	ns

NO. (1)	PARAMETER	DESCRIPTION	MODE	MIN	MAX	UNIT
O5	$t_{d(\text{CLK-CSn})}$	Delay time, CLK rising edge to CSn inactive edge	1.8V, OSPI0 DDR TX; 1.8V, OSPI1 DDR TX	$-7+0.475 * P$ $+ 0.975 * N * R$ (3) (4) (5)	$0.525 * P +$ $1.025 * N * R$ $+ 1$ (3) (4) (5)	ns
			3.3V, OSPI0 DDR TX; 3.3V, OSPI1 DDR TX	$-7+0.475 * P$ $+ 0.975 * N * R$ (3) (4) (5)	$0.525 * P +$ $1.025 * N * R$ $+ 1$ (3) (4) (5)	ns
O6	$t_{d(\text{CLK-D})}$	Delay time, CLK active edge to D[i:0] transition	1.8V, OSPI0 DDR TX; 1.8V, OSPI1 DDR TX	-7.7	-1.56	ns
			3.3V, OSPI0 DDR TX; 3.3V, OSPI1 DDR TX	-7.7	-1.56	ns

- (1) i in [i:0] = 7 for OSPI0, i in [i:0] = 3 for OSPI1
- (2) P = CLK cycle time
- (3) P = SCLK period
- (4) M = OSPI_DEV_DELAY_REG[D_INIT_FLD], N = OSPI_DEV_DELAY_REG[D_AFTER_FLD]
- (5) R = refclk

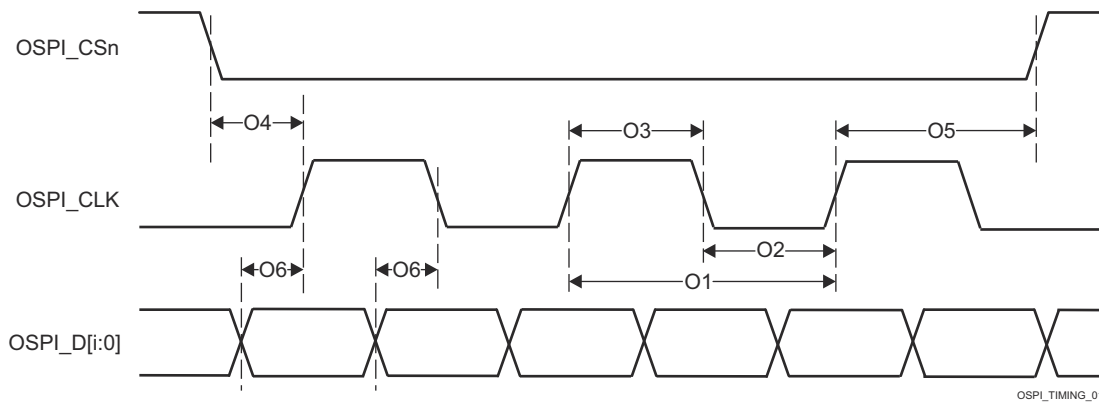

Figure 7-104. OSPI Switching Characteristics – DDR

7.9.5.18.2.2 OSPI Switching Characteristics – SDR Mode

NO. (1)	PARAMETER	DESCRIPTION	MODE	MIN	MAX	UNIT
O7	$t_{c(\text{CLK})}$	Cycle time, CLK	1.8V	7		ns
			3.3V	7.52		ns
O8	$t_{w(\text{CLKL})}$	Pulse duration, CLK low		$-0.3+0.475*P$ (2)		ns
O9	$t_{w(\text{CLKH})}$	Pulse duration, CLK high		$-0.3+0.475*P$ (2)		ns
O10	$t_{d(\text{CLK-CSn})}$	Delay time, CSn[3:0] active edge to CLK rising edge	1.8V	$-1-0.475 * P -$ $0.975 * N * R$ (3) (4) (5)	$0.525 * P +$ $1.025 * M * R$ $+ 1$ (3) (4) (5)	ns
			3.3V	$-1-0.475 * P -$ $0.975 * N * R$ (3) (4) (5)	$0.525 * P +$ $1.025 * M * R$ $+ 1$ (3) (4) (5)	ns
O11	$t_{d(\text{CLK-CSn})}$	Delay time, CLK rising edge to CSn inactive edge	1.8V	$-1+0.475 * P$ $+ 0.975 * N * R$ (3) (4) (5)	$0.525 * P +$ $1.025 * N * R$ $+ 1$ (3) (4) (5)	ns
			3.3V	$-1+0.475 * P$ $+ 0.975 * N * R$ (3) (4) (5)	$0.525 * P +$ $1.025 * N * R$ $+ 1$ (3) (4) (5)	ns
O12	$t_{d(\text{CLK-D})}$	Delay time, CLK active edge to D[i:0] transition	1.8V	-1.15	1.25	ns
			3.3V	-1.33	1.51	ns

- (1) i in [i:0] = 7 for OSPI0, i in [i:0] = 3 for OSPI1
- (2) P = CLK cycle time

- (3) P = SCLK period
- (4) M = OSPI_DEV_DELAY_REG[D_INIT_FLD], N = OSPI_DEV_DELAY_REG[D_AFTER_FLD]
- (5) R = refclk

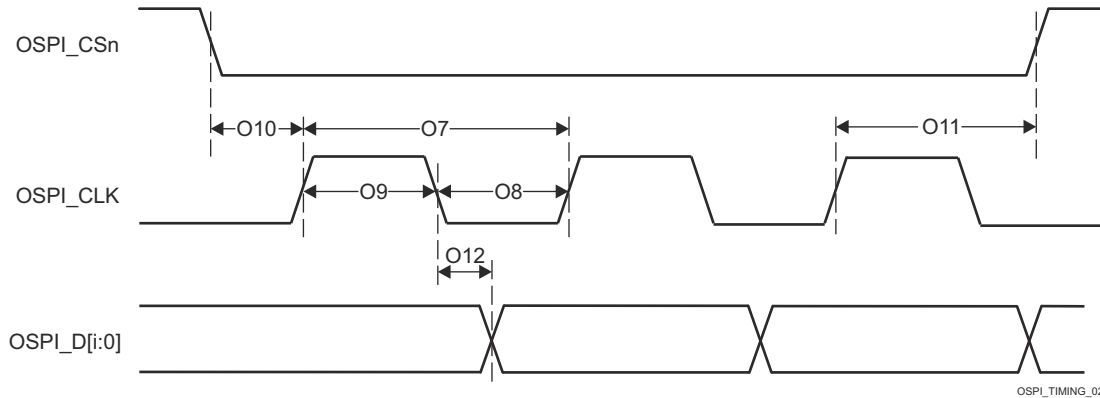

Figure 7-105. OSPI Switching Characteristics – SDR

Section 7.9.5.18.2.3, Section 7.9.5.18.2.4, Figure 7-106, Figure 7-107, Figure 7-108, and Figure 7-109 presents timing requirements for OSPI DDR and SDR Mode.

7.9.5.18.2.3 OSPI Timing Requirements – DDR Mode

NO. (1)	PARAMETER	DESCRIPTION	MODE	MIN	MAX	UNIT
O13	$t_{su(D-CLK)}$	Setup time, D[i:0] valid before active CLK edge	1.8V, No Loopback Clock; 1.8V, Internal Pad Loopback Clock	5.23		ns
			3.3V, No Loopback Clock; 3.3V, Internal Pad Loopback Clock	6.19		ns
O14	$t_{h(CLK-D)}$	Hold time, D[i:0] valid after active CLK edge	1.8V, No Loopback Clock; 1.8V, Internal Pad Loopback Clock	1.84		ns
			3.3V, No Loopback Clock; 3.3V, Internal Pad Loopback Clock	2.34		ns
O15	$t_{su(D-LBCLK)}$	Setup time, D[i:0] valid before active LBCLK (DQS) edge	1.8V, External Board Loopback Clock	0.52		ns
			3.3V, External Board Loopback Clock	1.97		ns
O16	$t_{h(LBCLK-D)}$	Hold time, D[i:0] valid after active LBCLK (DQS) edge	1.8V, External Board Loopback Clock	1.2 (2)		ns
			3.3V, External Board Loopback Clock	1.44 (2)		ns
O17	$t_{su(D-DQS)}$	Setup time, DQS edge to D[i:0] transition	1.8V, OSPI0 DQS; 1.8V, OSPI1 DQS	-0.46		ns
			3.3V, OSPI0 DQS; 3.3V, OSPI1 DQS	-0.66		ns
O18	$t_{h(DQS-D)}$	Hold time, DQS edge to D[i:0] transition	1.8V, OSPI0 DQS; 1.8V, OSPI1 DQS	3.59		ns
			3.3V, OSPI0 DQS; 3.3V, OSPI1 DQS	7.92		ns

- (1) i in [i:0] = 7 for OSPI0, i in [i:0] = 3 for OSPI1
- (2) This Hold time requirement is larger than the Hold time provided by a typical flash device. Therefore, the trace length between the SoC and flash device must be sufficiently long enough to ensure that the Hold time is met at the SoC. The length of the SoC's external loopback clock (OSPI_LBCLKO to OSPI_DQS) may need to be shortened to compensate.

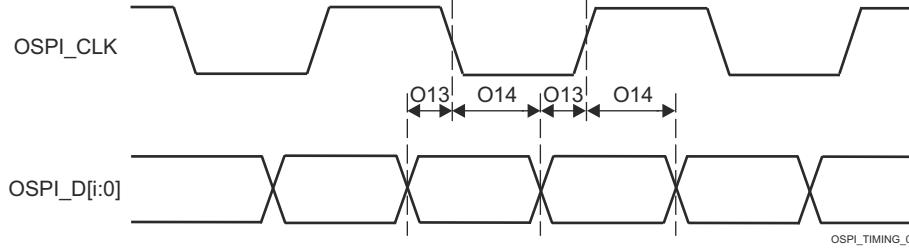

Figure 7-106. OSPI Timing Requirements – DDR, No Loopback Clock and Internal Pad Loopback Clock

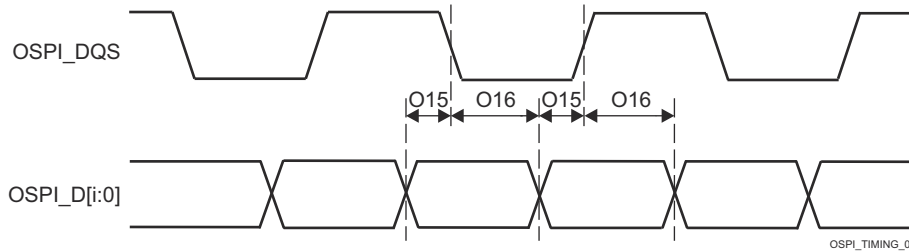

Figure 7-107. OSPI Timing Requirements – DDR, External Loopback Clock and DQS

7.9.5.18.2.4 OSPI Timing Requirements – SDR Mode

NO. (1)	PARAMETER	DESCRIPTION	MODE	MIN	MAX	UNIT
O19	$t_{su}(D-CLK)$	Setup time, D[i:0] valid before active CLK edge	1.8V, No Loopback Clock	4.8		ns
			3.3V, No Loopback Clock	5.39		ns
O20	$t_h(CLK-D)$	Hold time, D[i:0] valid after active CLK edge	1.8V, No Loopback Clock	-0.5		ns
			3.3V, No Loopback Clock	-0.5		ns
O21	$t_{su}(D-LBCLK)$	Setup time, D[i:0] valid before active LBCLK input (DQS) edge	1.8V, External Board Loopback Clock	0.6		ns
			3.3V, External Board Loopback Clock	0.9		ns
O22	$t_h(LBCLK-D)$	Hold time, D[i:0] valid after active LBCLK input (DQS) edge	1.8V, External Board Loopback Clock	1.7		ns
			3.3V, External Board Loopback Clock	2		ns

(1) i in [i:0] = 7 for OSPI0, i in [i:0] = 3 for OSPI1

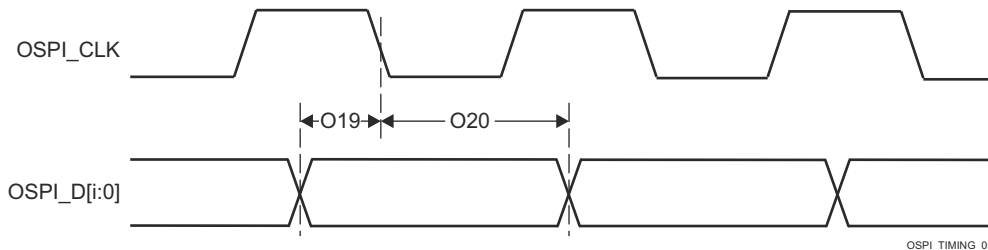

Figure 7-108. OSPI Timing Requirements – SDR, No Loopback Clock and Internal Pad Loopback Clock

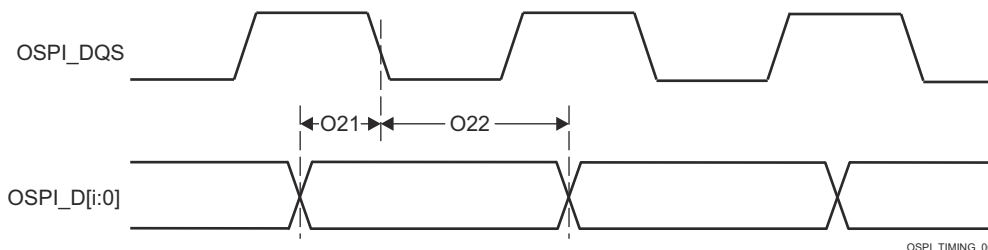

Figure 7-109. OSPI Timing Requirements – SDR, External Loopback Clock

Table 7-79. OSPI DLL Delay Mapping for Timing Modes

MODE	OSPI_PHY_CONFIGURATION_REG BIT FIELD	DELAY VALUE
TRANSMIT		
1.8 V	PHY_CONFIG_TX_DLL_DELAY_FLD	0x54
3.3 V	PHY_CONFIG_TX_DLL_DELAY_FLD	0x55
RECEIVE		
1.8 V, DQS	PHY_CONFIG_RX_DLL_DELAY_FLD	0x2D
3.3 V, DQS	PHY_CONFIG_RX_DLL_DELAY_FLD	0x29
All other modes	PHY_CONFIG_RX_DLL_DELAY_FLD	0x0

For more information, see *Octal Serial Peripheral Interface (OSPI)* section in *Peripherals* chapter in the device TRM.

7.9.5.19 PCIE

The PCI-Express Subsystem is compliant with the PCIe® Base Specification, Revision 4.0. Refer to the specification for timing details.

For more details about features and additional description information on the device Peripheral Component Interconnect Express, see the corresponding sections within [Section 6.3, Signal Descriptions](#) and [Section 8, Detailed Description](#).

For more information, see *Peripheral Component Interconnect Express (PCIe) Subsystem* section in *Peripherals* chapter in the device TRM.

7.9.5.20 Timers

For more details about features and additional description information on the device Timers, see the corresponding sections within [Section 6.3, Signal Descriptions](#) and [Section 8, Detailed Description](#).

[Table 7-80](#) represents Timers timing conditions.

Table 7-80. Timers Timing Conditions

PARAMETER	DESCRIPTION	MODE	MIN	MAX	UNIT
Input Conditions					
t _{SR}	Input slew rate	CAPTURE	0.5	5	V/ns
Output Conditions					
C _{LOAD}	Output load capacitance	PWM	2	10	pF

[Section 7.9.5.20.1](#), [Section 7.9.5.20.2](#) and [Figure 7-110](#) present timings and switching characteristics of the Timers.

7.9.5.20.1 Timing Requirements for Timers

NO.	PARAMETER	DESCRIPTION	MODE	MIN	MAX	UNIT
T1	t _{w(TINPH)}	Pulse duration, high	CAPTURE	2.5 + 4P ⁽¹⁾		ns
T2	t _{w(TINPL)}	Pulse duration, low	CAPTURE	2.5 + 4P ⁽¹⁾		ns

(1) P = functional clock period in ns.

7.9.5.20.2 Switching Characteristics for Timers

NO.	PARAMETER	DESCRIPTION	MODE	MIN	MAX	UNIT
T3	t _{w(TOOUTH)}	Pulse duration, high	PWM	-2.5 + 4P ⁽¹⁾		ns

NO.	PARAMETER	DESCRIPTION	MODE	MIN	MAX	UNIT
T4	$t_{w(TOURL)}$	Pulse duration, low	PWM	-2.5 + 4P ⁽¹⁾		ns

(1) P = functional clock period in ns.

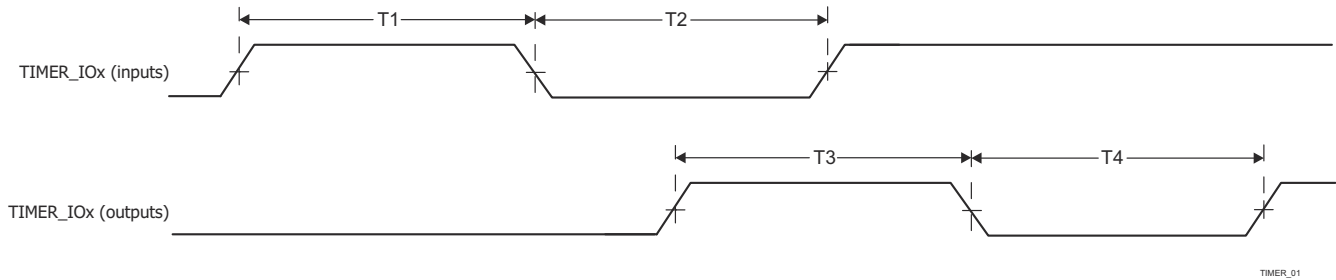

Figure 7-110. Timer Timing

For more information, see *Timers* section in *Peripherals* chapter in the device TRM.

7.9.5.21 UART

For more details about features and additional description information on the device Universal Asynchronous Receiver Transmitter, see the corresponding sections within [Section 6.3, Signal Descriptions](#) and [Section 8, Detailed Description](#).

[Table 7-81](#) represents UART timing conditions.

Table 7-81. UART Timing Conditions

PARAMETER	DESCRIPTION	MIN	MAX	UNIT
Input Conditions				
t_{SR}	Input slew rate	0.5	5	V/ns
Output Conditions				
C_{LOAD}	Output load capacitance	1	30 ⁽¹⁾	pF

(1) This value represents an absolute maximum load capacitance. As the UART baud rate increases, it may be necessary to reduce the load capacitance to a value less than this maximum limit to provide enough timing margin for the attached device. The output rise/fall times increase as capacitive load increases, which decreases the time data is valid for the receiver of the attached devices. Therefore, it is important to understand the minimum data valid time required by the attached device at the operating baud rate. Then use the device IBIS models to verify the actual load capacitance on the UART signals does not increase the rise/fall times beyond the point where the minimum data valid time of the attached device is violated.

[Section 7.9.5.21.1](#), [Section 7.9.5.21.2](#), and [Figure 7-111](#) present timing requirements and switching characteristics for UART interface.

7.9.5.21.1 UART Timing Requirements

NO.	PARAMETER	DESCRIPTION	MIN	MAX	UNIT
4	$t_{w(RX)}$	Pulse width, receive data bit, high or low	0.95U ⁽¹⁾ (2)	1.05U ⁽¹⁾ (2)	ns
5	$t_{w(CTS)}$	Pulse width, receive start bit, high or low	0.95U ⁽¹⁾ (2)		ns

(1) U = UART baud time = 1/Programmed baud rate

(2) This value defines the data valid time, where the input voltage is required to be above V_{IH} or below V_{IL} .

7.9.5.21.2 UART Switching Characteristics

NO.	PARAMETER	DESCRIPTION	MIN	MAX	UNIT
	$f_{(baud)}$	Maximum programmable baud rate		12	Mbps
2	$t_{w(TX)}$	Pulse width, transmit data bit, high or low	U - 2 ⁽¹⁾	U + 2 ⁽¹⁾	ns

NO.	PARAMETER	DESCRIPTION	MIN	MAX	UNIT
3	$t_{w(RTS)}$	Pulse width, transmit start bit, high or low	U - 2 ⁽¹⁾		ns

(1) U = UART baud time = 1/Programmed baud rate

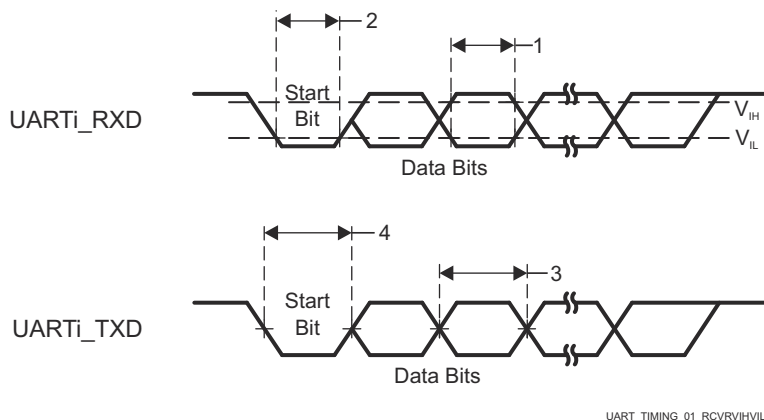

Figure 7-111. UART Timing

For more information, see *Universal Asynchronous Receiver/Transmitter (UART)* section in *Peripherals* chapter in the device TRM.

7.9.5.22 USB

The USB 2.0 subsystem is compliant with the Universal Serial Bus (USB) Specification, revision 2.0. Refer to the specification for timing details.

The USB 3.1 GEN1 Dual-Role Device Subsystem is compliant with the Universal Serial Bus (USB) 3.1 Specification, revision 1.0. Refer to the specification for timing details.

For more details about features and additional description information on the device Universal Serial Bus Subsystem (USB), see the corresponding sections within [Section 6.3, Signal Descriptions](#) and [Section 8, Detailed Description](#).

For more information, see *Universal Serial Bus (USB) Subsystem* section in *Peripherals* chapter in the device TRM.

7.9.6 Emulation and Debug

7.9.6.1 Debug Trace

[Table 7-83](#) represents Debug Trace timing conditions.

Table 7-82. Debug Trace Timing Conditions

PARAMETER		MIN	MAX	UNIT
Output Conditions				
C_L	Output load capacitance	2	5	pF
PCB CONNECTIVITY REQUIREMENTS				
$t_d(\text{Trace Mismatch})$	Propagation delay mismatch across all traces		200	ps

[Table 7-83](#) and [Figure 7-112](#) assume testing over the recommended operating conditions and electrical characteristic conditions.

Table 7-83. Debug Trace Switching Characteristics

NO.	PARAMETER	DESCRIPTION	MIN	MAX	UNIT
1.8 V Mode					
DBTR1	$t_c(\text{TRC_CLK})$	Cycle time, TRC_CLK	6.50		ns
DBTR2	$t_w(\text{TRC_CLKH})$	Pulse width, TRC_CLK high	2.50		ns

Table 7-83. Debug Trace Switching Characteristics (continued)

NO.	PARAMETER	DESCRIPTION	MIN	MAX	UNIT
DBTR3	$t_w(\text{TRC_CLKL})$	Pulse width, TRC_CLK low	2.50		ns
DBTR4	$t_{\text{osu}}(\text{TRC_DATAV-TRC_CLK})$	Output setup time, TRC_DATA valid to TRC_CLK edge	0.81		ns
DBTR5	$t_{\text{oh}}(\text{TRC_CLK-TRC_DATAI})$	Output hold time, TRC_CLK edge to TRC_DATA invalid	0.81		ns
DBTR6	$t_{\text{osu}}(\text{TRC_CTLV-TRC_CLK})$	Output setup time, TRC_CTL valid to TRC_CLK edge	0.81		ns
DBTR7	$t_{\text{oh}}(\text{TRC_CLK-TRC_CTLI})$	Output hold time, TRC_CLK edge to TRC_CTL invalid	0.81		ns
3.3 V Mode					
DBTR1	$t_c(\text{TRC_CLK})$	Cycle time, TRC_CLK	9.75		ns
DBTR2	$t_w(\text{TRC_CLKH})$	Pulse width, TRC_CLK high	4.13		ns
DBTR3	$t_w(\text{TRC_CLKL})$	Pulse width, TRC_CLK low	4.13		ns
DBTR4	$t_{\text{osu}}(\text{TRC_DATAV-TRC_CLK})$	Output setup time, TRC_DATA valid to TRC_CLK edge	1.22		ns
DBTR5	$t_{\text{oh}}(\text{TRC_CLK-TRC_DATAI})$	Output hold time, TRC_CLK edge to TRC_DATA invalid	1.22		ns
DBTR6	$t_{\text{osu}}(\text{TRC_CTLV-TRC_CLK})$	Output setup time, TRC_CTL valid to TRC_CLK edge	1.22		ns
DBTR7	$t_{\text{oh}}(\text{TRC_CLK-TRC_CTLI})$	Output hold time, TRC_CLK edge to TRC_CTL invalid	1.22		ns

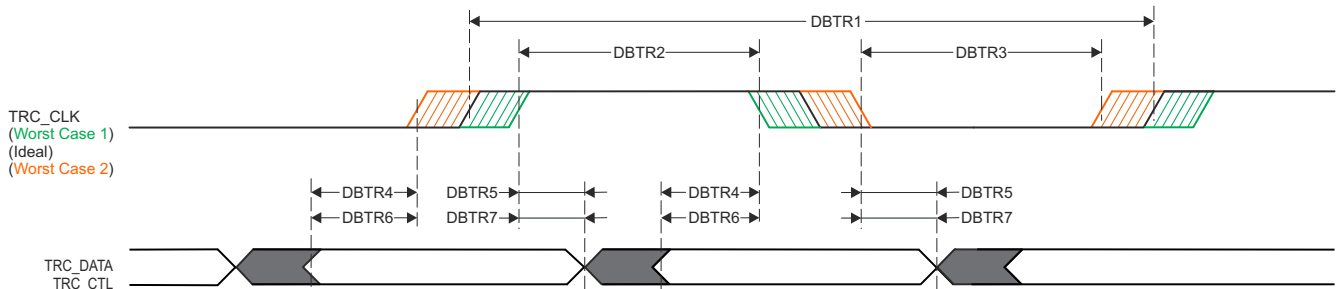

SPRSP08_Debug_01

Figure 7-112. Debug Trace Timing

7.9.6.2 IEEE 1149.1 Standard–Test–Access Port (JTAG)

For more details about features and additional description information on the device IEEE 1149.1 Standard–Test–Access Port, see the corresponding sections within [Section 6.3, Signal Descriptions](#) and [Section 8, Detailed Description](#).

Table 7-84 represents JTAG timing conditions.

Note

The JTAG signals are split across two IO power domains on the device. Timings parameters defined in this section only apply when the two IO power domains are operating at the same voltage and level-shifters are not inserted into the signal path. Values for the following timing parameters are not defined when operating the two IO power domains at different voltages since propagation delay through the device IO buffers differ when some are operating at 1.8V while others are operating at 3.3V. This effectively reduces timing margin beyond the values defined in this section. The JTAG interface is still expected to function when the two IO power domains are operated at different voltages, assuming the system designer has implemented appropriate level-shifters and the operating frequency is reduced to accommodate additional delay inserted by the level-shifters and IO buffers operating at different voltages

Table 7-84. JTAG Timing Conditions

PARAMETER		MIN	MAX	UNIT
Input Conditions				
t_{SR}	Input slew rate	0.50	2.00	V/ns
Output Conditions				
C_L	Output load capacitance	5	15	pF
PCB CONNECTIVITY REQUIREMENTS				
$t_d(\text{Trace Delay})$	Propagation delay of each trace	83.5	1000 ⁽¹⁾	ps
$t_d(\text{Trace Mismatch Delay})$	Propagation delay mismatch across all traces		100	ps

(1) Maximum propagation delay associated with the JTAG signal traces has a significant impact on maximum TCK operating frequency. It may be possible to increase the trace delay beyond this value, but the operating frequency of TCK must be reduced to account for the additional trace delay.

7.9.6.2.1 JTAG Electrical Data and Timing

Section 7.9.6.2.1.1, Section 7.9.6.2.1.2, and Figure 7-113 assume testing over the recommended operating conditions and electrical characteristic conditions.

7.9.6.2.1.1 Timing Requirements for IEEE 1149.1 JTAG

NO.	PARAMETER	DESCRIPTION	MIN	MAX	UNIT
J1	$t_c(\text{TCK})$	Cycle time minimum, TCK	46.5 ⁽¹⁾		ns
J2	$t_w(\text{TCKH})$	Pulse width minimum, TCK high	0.4P ⁽²⁾		ns
J3	$t_w(\text{TCKL})$	Pulse width minimum, TCK low	0.4P ⁽²⁾		ns
J4	$t_{su}(\text{TDI-TCK})$	Input setup time minimum, TDI valid to TCK high	4.5		ns
	$t_{su}(\text{TMS-TCK})$	Input setup time minimum, TMS valid to TCK high	4.5		ns
J5	$t_h(\text{TCK-TDI})$	Input hold time minimum, TDI valid from TCK high	2		ns
	$t_h(\text{TCK-TMS})$	Input hold time minimum, TMS valid from TCK high	2		ns

(1) The maximum TCK operating frequency assumes the following timing requirements and switching characteristics for the attached debugger. The operating frequency of TCK must be reduced to provide appropriate timing margin if the debugger exceeds any of these assumptions.

- Minimum TDO setup time of 4.6 ns relative to the rising edge of TCK
- TDI and TMS output delay in the range of -16.5 ns to 14.0 ns relative to the falling edge of TCK

(2) P = TCK cycle time in ns

7.9.6.2.1.2 Switching Characteristics Over Recommended Operating Conditions for IEEE 1149.1 JTAG

NO.	PARAMETER	DESCRIPTION	MIN	MAX	UNIT
J6	$t_d(\text{TCKL-TDO})$	Delay time minimum, TCK low to TDO invalid	0		ns
J7	$t_d(\text{TCKL-TDOV})$	Delay time maximum, TCK low to TDO valid		12	ns

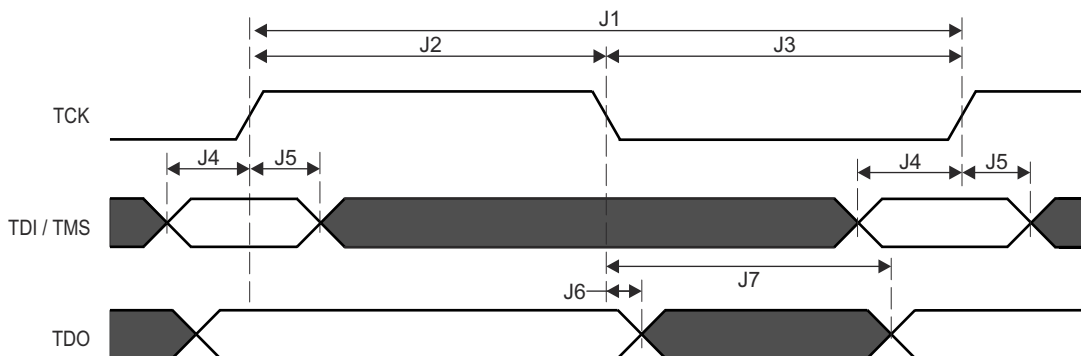

Figure 7-113. JTAG Test-Port Timing

8 Detailed Description

8.1 Overview

Jacinto™ DRA821x processors, based on the Armv8 64-bit architecture, are System-on-Chip (SoCs) that provide lower system cost through integration of features including system MCU, Ethernet switch, safety, security. Multi-core system enables ECU consolidation for automotive applications such as automotive gateway and vehicle compute systems. The integrated diagnostics and functional safety features are targeted to ASIL-D certification/requirements. The Integrated Microcontroller (MCU) island eliminates the need for an external system MCU. In addition to the PCIe hub, the device features up to four Gigabit Ethernet ports with integrated switch to meet networking use cases that require heavy data bandwidth and also includes PCIe hub functionality. Twenty CAN-FD and up to twelve UART interfaces are available on the device. Up to four general purpose Arm® Cortex®-R5F subsystems can handle low level, timing critical processing tasks and leave the Arm® Cortex®-A72's unencumbered for advanced applications.

Note

For more information on features, subsystems, and architecture of superset device System on Chip (SoC), see the device TRM.

8.2 Processor Subsystems

8.2.1 Arm Cortex-A72

The device implements one dual-core Arm® Cortex®-A72 MPU, which is integrated inside the Compute Cluster, along with other modules. The Cortex-A72 cores are general-purpose processors that can be used for running customer applications.

The A72SS is built around the Arm Cortex-A72 MPCore (A72 cluster), which is provided by Arm and configured by TI. It is based on the symmetric multiprocessor (SMP) architecture, and thus it delivers high performance and optimal power management and debug capabilities.

The A72 processor is a multi-issue out-of-order superscalar execution engine with integrated L1 instruction and data caches, compatible with Armv8-A architecture. The Armv8-A architecture brings a number of new features. These include 64-bit data processing, extended virtual addressing and 64-bit general purpose registers.

For more information, see *Dual-A72 MPU Subsystem* section in *Processors and Accelerators* chapter in the device TRM.

8.2.2 Arm Cortex-R5F

The MCU_ARMSS is a dual-core implementation of the Arm® Cortex®-R5F processor configured for split/lock operation. It also includes accompanying memories (L1 caches and tightly-coupled memories), standard Arm® CoreSight™ debug and trace architecture, integrated Vectored Interrupt Manager (VIM), ECC Aggregators, and various wrappers for protocol conversion and address translation for easy integration into the SoC.

For more information, see *Dual-R5F MCU Subsystem* section in *Processors and Accelerators* chapter in the device TRM.

8.3 Other Subsystems

8.3.1 MSMC

The Multicore Shared Memory Controller (MSMC) forms the heart of the compute cluster (COMPUTE_CLUSTER0) providing high-bandwidth resource access both to and from all of the connected processing elements and the rest of the system. MSMC serves as the data-movement backbone of the compute cluster.

For more information, see *Multicore Shared Memory Controller (MSMC)* section in *Device Configuration* chapter in the device TRM.

8.3.2 NAVSS

8.3.2.1 NAVSS0

Main SoC Navigator Subsystem (NAVSS0) consists of DMA/Queue Management components – UDMA and Ring Accelerator (UDMASS), Peripherals (Module subsystem [MODSS]), Virtualization translation (VirtSS), and a North Bridge (NBSS).

8.3.2.2 MCU_NAVSS

MCU Navigator Subsystem (MCU NAVSS) has a subset of the modules of the main NAVSS and is instantiated in the MCU domain.

MCU Navigator Subsystem consists of DMA/Queue Management components – UDMA and Ring Accelerator (UDMASS), and Peripherals (Module subsystem [MODSS]).

For more information, see *Main Navigator Subsystem (NAVSS)* and *MCU Navigator Subsystem (MCU NAVSS)* sections in *Data Movement Architecture (DMA)* chapter in the device TRM.

8.3.3 PDMA Controller

The Peripheral DMA is a simple DMA which has been architected to specifically meet the data transfer needs of peripherals, which perform data transfers using memory mapped registers accessed via a standard non-coherent bus fabric. The PDMA module is intended to be located close to one or more peripherals which

require an external DMA for data movement and is architected to reduce cost by using VBUSP interfaces and supporting only statically configured Transfer Request (TR) operations.

The PDMA is only responsible for performing the data movement transactions which interact with the peripherals themselves. Data which is read from a given peripheral is packed by a PDMA source channel into a PSI-L data stream which is then sent to a remote peer UDMA-P destination channel which then performs the movement of the data into memory. Likewise, a remote UDMA-P source channel fetches data from memory and transfers it to a peer PDMA destination channel over PSI-L which then performs the writes to the peripheral.

The PDMA architecture is intentionally heterogeneous (UDMA-P + PDMA) to right size the data transfer complexity at each point in the system to match the requirements of whatever is being transferred to or from. Peripherals are typically FIFO based and do not require multi-dimensional transfers beyond their FIFO dimensioning requirements, so the PDMA transfer engines are kept simple with only a few dimensions (typically for sample size and FIFO depth), hardcoded address maps, and simple triggering capabilities.

Multiple source and destination channels are provided within the PDMA which allow multiple simultaneous transfer operations to be ongoing. The DMA controller maintains state information for each of the channels and employs round-robin scheduling between channels in order to share the underlying DMA hardware.

For more information, see *PDMA Controller* section in *DMA Controllers* chapter in the device TRM.

8.3.4 Peripherals

8.3.4.1 ADC

The Analog-to-Digital Converter (ADC) module contains a single 12-bit ADC which can be multiplexed to any 1 of 8 analog inputs (channels).

For more information, see *Analog-to-Digital Converter (ADC)* section in *Peripherals* chapter in the device TRM.

8.3.4.2 ATL

The Audio Tracking Logic (ATL) is used by HD Radio™ applications to synchronize the digital audio output to the baseband clock. This same IP can also be used generically to track errors between two reference signals (such as frame syncs) and generate a modulated clock output (using software-controlled cycle stealing) which averages to some desired frequency. This process can be used as a hardware assist for asynchronous sample rate conversion algorithms.

For more information, see *Audio Tracking Logic (ATL)* section in *Peripherals* chapter in the device TRM.

8.3.4.3 CPSW2G

The two-port Gigabit Ethernet MAC (MCU_CPSW0) subsystem provides Ethernet packet communication for the device and is configured in a similar manner as an Ethernet switch. MCU_CPSW0 features the Reduced Gigabit Media Independent Interface (RGMII), Reduced Media Independent Interface (RMII), and the Management Data Input/Output (MDIO) interface for physical layer device (PHY) management.

For more information, see *Gigabit Ethernet Switch (CPSW0)* section in *Peripherals* chapter in the device TRM.

8.3.4.4 CPSW5G

The 5-port Gigabit Ethernet Switch (CPSW0) subsystem provides Ethernet packet communication for the device and can be configured as an Ethernet switch. CPSW0 features the 1G and 2.5G Serial Gigabit Media Independent Interface (SGMII), Universal Serial 10G Media Independent Interface (USXGMII), 10G Form-factor Interface (XFI), Reduced Gigabit Media Independent Interface (RGMII), Reduced Media Independent Interface (RMII) and the Management Data Input/Output (MDIO) interface for physical layer device (PHY) management.

For more information, see *Gigabit Ethernet Switch (MCU_CPSW0)* section in *Peripherals* chapter in the device TRM.

8.3.4.5 DCC

The Dual Clock Comparator (DCC) is used to determine the accuracy of a clock signal during the time execution of an application. Specifically, the DCC is designed to detect drifts from the expected clock frequency.

The desired accuracy can be programmed based on calculation for each application. The DCC measures the frequency of a selectable clock source using another input clock as a reference.

For more information, see *Dual Clock Comparator (DCC)* section in *Peripherals* chapter in the device TRM.

8.3.4.6 DDRSS

The DDR subsystem in this device comprises DDR controller, DDR PHY and wrapper logic to integrate these blocks in the device. The DDR subsystem is referred to as DDRSS0 and is used to provide an interface to external SDRAM devices which can be utilized for storing program or data. Specifically, the DDR subsystem supports LPDDR4 devices compliant to the JEDEC JESD209-4B standard. DDRSS0 is accessed via MSMC, and not directly through the system interconnect.

Note

The DDRSS does not support byte mode LPDDR4 memories, or memories with more than 17 row address bits.

For more information, see *DDR Subsystem (DDRSS)* section in *Peripherals* chapter in the device TRM.

8.3.4.7 ECAP

The enhanced Capture (ECAP) module can be used for:

- Sample rate measurements of audio inputs
- Speed measurements of rotating machinery (for example, toothed sprockets sensed via Hall sensors)
- Elapsed time measurements between position sensor pulses
- Period and duty cycle measurements of pulse train signals
- Decoding current or voltage amplitude derived from duty cycle encoded current/voltage sensors.

For more information, see *Enhanced Capture (ECAP) Module* section in *Peripherals* chapter in the device TRM.

8.3.4.8 EPWM

An effective PWM peripheral must be able to generate complex pulse width waveforms with minimal CPU overhead or intervention. It needs to be highly programmable and very flexible while being easy to understand and use. The EPWM unit described here addresses these requirements by allocating all needed timing and control resources on a per PWM channel basis. Cross coupling or sharing of resources has been avoided; instead, the EPWM is built up from smaller single channel modules with separate resources and that can operate together as required to form a system. This modular approach results in an orthogonal architecture and provides a more transparent view of the peripheral structure, helping users to understand its operation quickly.

In the further description the letter x within a signal or module name is used to indicate a generic EPWM instance on a device. For example, output signals EPWMxA and EPWMxB refer to the output signals from the EPWM_x instance. Thus, EPWM1A and EPWM1B belong to EPWM1, EPWM2A and EPWM2B belong to EPWM2, and so forth.

Additionally, the EPWM integration allows this synchronization scheme to be extended to the capture peripheral modules (ECAP). The number of modules is device-dependent and based on target application needs. Modules can also operate stand-alone.

For more information, see *Enhanced Pulse Width Modulation (EPWM) Module* section in *Peripherals* chapter in the device TRM.

8.3.4.9 ELM

The Error Location Module (ELM) is used with the GPMC. Syndrome polynomials generated on-the-fly when reading a NAND flash page and stored in GPMC registers are passed to the ELM. A host processor can then correct the data block by flipping the bits to which the ELM error-location outputs point.

When reading from NAND flash memories, some level of error-correction is required. In the case of NAND modules with no internal correction capability, sometimes referred to as *bare NANDs*, the correction process is delegated to the memory controller. ELM can be also used to support parallel NOR flash or NAND flash.

For more information, see *Error Location Module (ELM)* section in *Peripherals* chapter in the device TRM.

8.3.4.10 ESM

The Error Signaling Module (ESM) aggregates events and/or errors from throughout the device into one location. It can signal both low and high priority interrupts to a processor to deal with an event and/or manipulate an I/O error pin to signal an external hardware that an error has occurred. Therefore an external controller is able to reset the device or keep the system in a safe, known state.

For more information, see *Error Signaling Module (ESM)* section in *Peripherals* chapter in the device TRM.

8.3.4.11 EQEP

The Enhanced Quadrature Encoder Pulse (EQEP) peripheral is used for direct interface with a linear or rotary incremental encoder to get position, direction and speed information from a rotating machine for use in high performance motion and position control system. The disk of an incremental encoder is patterned with a single track of slots patterns. These slots create an alternating pattern of dark and light lines. The disk count is defined as the number of dark/light line pairs that occur per revolution (lines per revolution). As a rule, a second track is added to generate a signal that occurs once per revolution (index signal: QEPI), which can be used to indicate an absolute position. Encoder manufacturers identify the index pulse using different terms such as index, marker, home position and zero reference.

For more information, see *Enhanced Quadrature Encoder Pulse (EQEP) Module* section in *Peripherals* chapter in the device TRM.

8.3.4.12 GPIO

The General-Purpose Input/Output (GPIO) peripheral provides dedicated general-purpose pins that can be configured as either inputs or outputs. When configured as an output, the user can write to an internal register to control the state driven on the output pin. When configured as an input, user can obtain the state of the input by reading the state of an internal register.

In addition, the GPIO peripheral can produce host CPU interrupts and DMA synchronization events in different interrupt/event generation modes.

For more information, see *General-Purpose Interface (GPIO)* section in *Peripherals* chapter in the device TRM.

8.3.4.13 GPMC

The General-Purpose Memory Controller is a unified memory controller dedicated for interfacing with external memory devices like:

- Asynchronous SRAM-like memories and application-specific integrated circuit (ASIC) devices
- Asynchronous, synchronous, and page mode (available only in non-multiplexed mode) burst NOR flash devices
- NAND flash
- Pseudo-SRAM devices

For more information, see *General-Purpose Memory Controller (GPMC)* section in *Peripherals* chapter in the device TRM.

8.3.4.14 Hyperbus

The Hyperbus module is a part in the device Flash Subsystem (FSS).

The Hyperbus module is a low pin count memory interface that provides high read/write performance. The Hyperbus module connects to Hyperbus memory (HyperFlash or HyperRAM) and uses simple Hyperbus protocol for read and write transactions.

There is one Hyperbus™ module inside the device. The Hyperbus module includes one Hyperbus Memory Controller (HBMC).

For more information, see *Hyperbus Interface* section in *Peripherals* chapter in the device TRM.

8.3.4.15 I2C

The device contains ten multimaster Inter-Integrated Circuit (I2C) controllers each of which provides an interface between a local host (LH), such as an Arm or a Digital Signal Processor (DSP), and any I²C-bus-compatible device that connects via the I²C serial bus. External components attached to the I²C bus can serially transmit and receive up to 8 bits of data to and from the LH device through the 2-wire I²C interface.

Each multimaster I2C module can be configured to act like a slave or master I²C-compatible device.

The WKUP_I2C0, MCU_I2C0, I2C0, and I2C1 controllers have dedicated I²C compliant open drain buffers, and support high speed mode (up to 3.4 Mbps in 1.8 V mode and up to 400 kbps in 3.3 V mode). The MCU_I2C1, I2C2, I2C3, I2C4, I2C5, and I2C6 controllers are multiplexed with standard LVCMOS I/O, connected to emulate open drain, and support fast mode (up to 400 kbps in 1.8 V/3.3 V mode). The I2C emulation is achieved by configuring the LVCMOS buffers to output Hi-Z instead of driving high when transmitting logic 1.

For more information, see *Inter-Integrated Circuit (I2C) Interface* section in *Peripherals* chapter in the device TRM.

8.3.4.16 I3C

The device contains three Improved Inter-Integrated Circuit (I3C) controllers each of which provides an interface between a local host (LH), such as an Arm, and any I3C-bus-compatible device that connects via the I3C serial bus.

For more information, see *Improved Inter-Integrated Circuit (I3C) Interface* section in *Peripherals* chapter in the device TRM.

8.3.4.17 MCAN

The Controller Area Network (CAN) is a serial communications protocol which efficiently supports distributed real-time control. CAN has high immunity to electrical interference. In a CAN network, many short messages are broadcast to the entire network, which provides for data consistency in every node of the system.

The MCAN module supports both classic CAN and CAN FD (CAN with Flexible Data-Rate) specifications. CAN FD feature allows high throughput and increased payload per data frame. The classic CAN and CAN FD devices can coexist on the same network without any conflict.

For more information, see *Modular Controller Area Network (MCAN)* section in *Peripherals* chapter in the device TRM.

8.3.4.18 MCASP

The MCASP functions as a general-purpose audio serial port are optimized to the requirements of various audio applications. The MCASP module can operate in both transmit and receive modes. The MCASP is useful for time-division multiplexed (TDM) stream, Inter-IC Sound (I2S) protocols reception and transmission as well as for an inter-component digital audio interface transmission (DIT). The MCASP has the flexibility to gluelessly connect to a Sony/Philips digital interface (S/PDIF) transmit physical layer component.

Although inter-component digital audio interface reception (DIR) mode (this is, S/PDIF stream receiving) is not natively supported by the MCASP module, a specific TDM mode implementation for the MCASP receivers allows an easy connection to external DIR components (for example, S/PDIF to I2S format converters).

For more information, see *Multichannel Audio Serial Port (MCASP)* section in *Peripherals* chapter in the device TRM.

8.3.4.19 MCRC Controller

VBUSM CRC controller is a module which is used to perform CRC (Cyclic Redundancy Check) to verify the integrity of a memory system. A signature representing the contents of the memory is obtained when the contents of the memory are read into MCRC Controller. The responsibility of MCRC controller is to calculate the signature for a set of data and then compare the calculated signature value against a predetermined good signature value. MCRC controller provides four channels to perform CRC calculation on multiple memories in

parallel and can be used on any memory system. Channel 1 can also be put into data trace mode, where MCRC controller compresses each data being read through CPU read data bus.

For more information, see *MCRC Controller* section in *Interprocessor Communication* chapter in the device TRM.

8.3.4.20 MCSPI

The MCSPI module is a multichannel transmit/receive, master/slave synchronous serial bus.

There are total of eleven MCSPI modules in the device.

For more information, see *Multichannel Serial Peripheral Interface (MCSPI)* section in *Peripherals* chapter in the device TRM.

8.3.4.21 MMC/SD

The MMCSd Host Controller provides an interface to eMMC 5.1 (embedded MultiMedia Card), SD 4.10 (Secure Digital), and SDIO 4.0 (Secure Digital IO) devices. The MMCSd Host Controller deals with MMC/SD/SDIO protocol at transmission level, data packing, adding cyclic redundancy checks (CRCs), start/end bit insertion, and checking for syntactical correctness.

For more information, see *Multimedia Card/Secure Digital (MMC/SD) Interface* section in *Peripherals* chapter in the device TRM.

8.3.4.22 OSPI

The Octal Serial Peripheral Interface (OSPI™) module is a kind of Serial Peripheral Interface (SPI) module which allows single, dual, quad or octal read and write access to external flash devices.

The OSPI module is used to transfer data, either in a memory mapped direct mode (for example a processor wishing to execute code directly from external flash memory), or in an indirect mode where the module is set-up to silently perform some requested operation, signaling its completion via interrupts or status registers.

For more information, see *Octal Serial Peripheral Interface (OSPI)* section in *Peripherals* chapter in the device TRM.

8.3.4.23 PCIE

The Peripheral Component Interconnect Express (PCIe) subsystem is built around a multi-lane dual-mode PCIe controller that provides low pin-count, high reliability, and high-speed data transfers at rates of up to 8.0 Gbps per lane for serial links on backplanes and printed wiring boards.

For more information, see *Peripheral Component Interconnect Express (PCIe) Subsystem* section in *Peripherals* chapter in the device TRM.

8.3.4.24 SerDes

SerDes'es goal is to convert device (SoC) parallel data into serialized data that can be output over a highspeed electrical interface. In the opposite direction, SerDes converts high-speed serial data into parallel data that can be processed by the device. To this end, the SerDes contains a variety of functional blocks to handle both the external analog interface as well as the internal digital logic.

For more information, see *Serializer/Deserializer (SerDes)* section in *Peripherals* chapter in the device TRM.

8.3.4.25 WWDT

The Windowed Watchdog Timer provides timer functionality for operating systems and for benchmarking code. The module incorporates several counters, which define the timebases needed for scheduling in the operating system. The module is implemented with an RTI module, but only WWDT is supported.

This module is specifically designed to fulfill the requirements for OSEK (“Offene Systeme und deren Schnittstellen für die Elektronik im Kraftfahrzeug”; “Open Systems and the Corresponding Interfaces for Automotive Electronics”) as well as OSEK/Time compliant operating systems.

For more information, see *Real Time Interrupt (RTI) Module* section in *Peripherals* chapter in the device TRM.

8.3.4.26 Timers

All timers include specific functions to generate accurate tick interrupts to the operating system.

Each timer can be clocked from several different independent clocks. The selection of clock source is made from registers in the MCU_CTRL_MMR0/CTRL_MMR0.

In the MCU domain the device provides 10 timer pins to be used as MCU Timer Capture inputs or as MCU Timer PWM outputs. In order to provide maximum flexibility, these 10 pins may be used with any of MCU_TIMER0 through MCU_TIMER9 instances. System level muxes are used to control the capture source pin for each MCU_TIMER[9-0] and the MCU_TIMER[9-0] source for each MCU_TIMER_IO[9-0] PWM output.

In the MAIN domain the device provides 8 timer pins to be used as Timer Capture inputs or as Timer PWM outputs. For maximum flexibility, these 8 pins may be used with any of TIMER0 through TIMER19 instances. System level muxes are used to control the capture source pin for each TIMER[19-0] and the TIMER[19-0] source for each TIMER_IO[7-0] PWM output.

Each odd numbered timer instance from each of the domains may be optionally cascaded with the previous even numbered timer instance from the same domain to form up to a 64-bit timer. For example, TIMER1 may be cascaded to TIMER0, MCU_TIMER1 may be cascaded to MCU_TIMER0, etc.

When cascaded, TIMER_i acts as a 32-bit prescaler to TIMER_{i+1}, as well as MCU_TIMER_n acts as a 32-bit prescaler to MCU_TIMER_{n+1}. TIMER_i / MCU_TIMER_n must be configured to generate a PWM output edge at the desired rate to increment the TIMER_{i+1} / MCU_TIMER_{n+1} counter.

For more information, see *Timers* section in *Peripherals* chapter in the device TRM.

8.3.4.27 UART

The UART is a slave peripheral that utilizes the DMA for data transfer or interrupt polling via host CPU. There are twelve UART modules in the device. All UART modules support IrDA and CIR modes when 48 MHz function clock is used. Each UART can be used for configuration and data exchange with a number of external peripheral devices or interprocessor communication between devices.

For more information, see *Universal Synchronous/Asynchronous Receiver/Transmitter (UART)* section in *Peripherals* chapter in the device TRM.

8.3.4.28 USB

Similar to earlier versions of USB bus, USB 3.0 is a general-purpose cable bus, supporting data exchange between a host device and a wide range of simultaneously accessible peripherals.

The device supports one USB subsystem:

- USB3SS0 is SuperSpeed (SS) USB 3.0 Dual-Role-Device (DRD) subsystem with on-chip SS (USB3.0) PHY and HS/FS/LS (1) (USB2.0) PHY

For more information, see *Universal Serial Bus (USB) Subsystem* section in *Peripherals* chapter in the device TRM.

9 Applications, Implementation, and Layout

Note

Information in the following applications sections is not part of the TI component specification, and TI does not warrant its accuracy or completeness. TI's customers are responsible for determining suitability of components for their purposes. Customers should validate and test design implementation to confirm system functionality.

9.1 Power Supply Mapping

TPS6594x and LP8764x are the Power Management ICs (PMIC) that should be used for Power Distribution Network (PDN) designs to support this device. TI requires use of these PMICs for the following reasons:

- TI has validated their use with the Device
- Board level margins including transient response and output accuracy are analyzed and optimized for the entire system
- Support for power sequencing requirements (refer to [Section 7.9.2, Power Supply Sequences](#))
- Support for Adaptive Voltage Scaling (AVS) Class 0 requirements, including TI provided software

When combining device voltage domains into a common power rail is allowed, the most stringent voltage domain PDN guideline must be implemented for the common power rail.

It is possible that some device voltage domains may be unused in some systems. In such cases, all unused voltage domain supply pins must still be connected to a valid power rail with a proper voltage level in order to ensure device reliability (refer to Section 4.3, Signal Descriptions). For example, if MCU is not used, then vdd_mcu domain can be combined with the CORE domain (vdd_core) that has the same voltage specifications. A buck converter power stage connected to the common power rail would then supply both CORE and MCU domains.

For the combined rail, the following relaxations apply:

- The AVS voltage of active rail in the combined rail needs to be used to set the power supply
- The decoupling capacitance should be set according to the active rail in the combined rail

[Figure 9-1](#) shows an example of the detailed power mapping between the processor and TPS659414-Q1 and LP876441-Q1 PMICs. In this configuration, both PMIC devices use a 3.3V input voltage. For more details, refer to the appnote titled "[User's Guide for Powering DRA821 with the TPS6594-Q1 and LP8764-Q1 PMICs](#)".

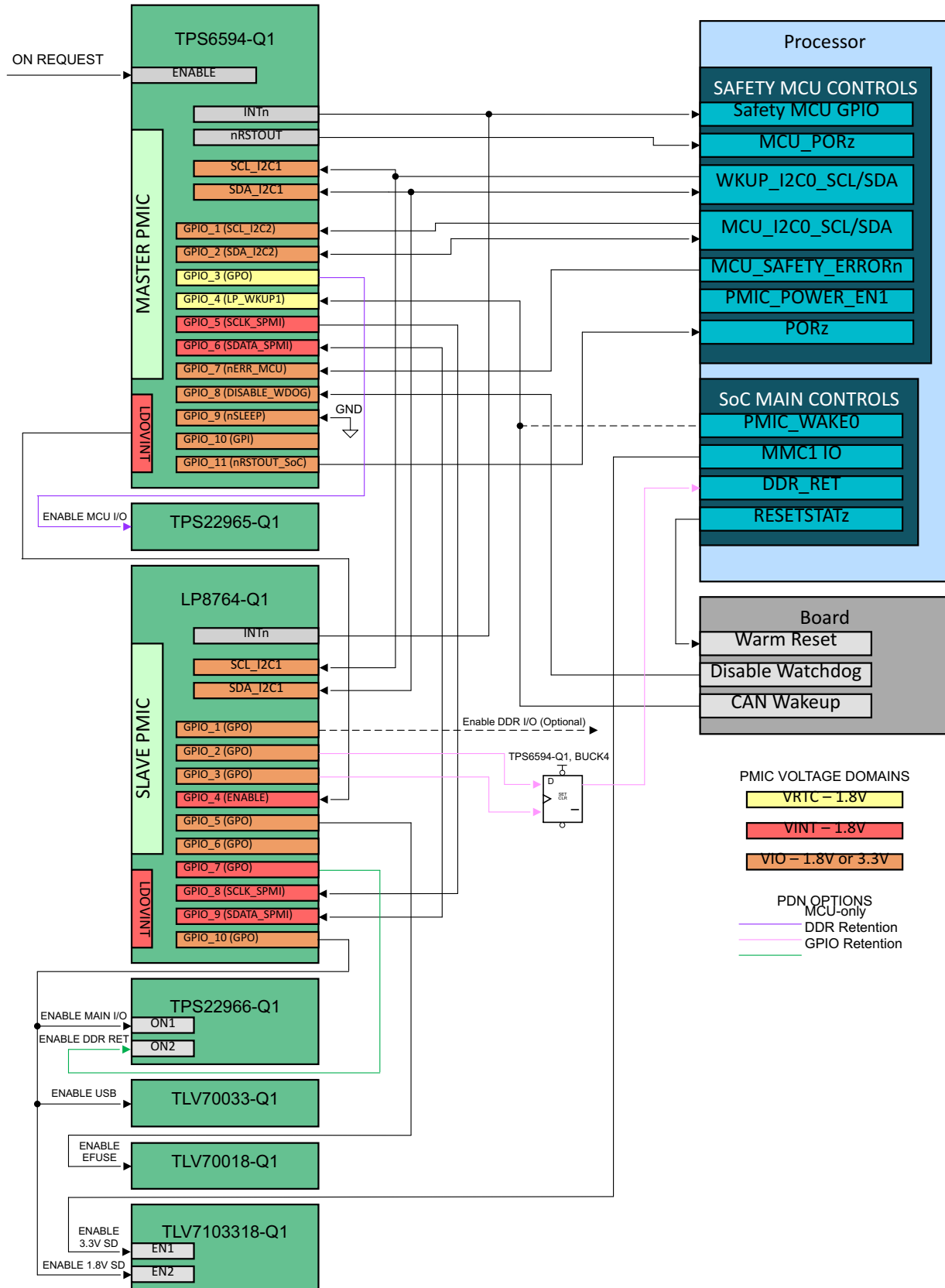

Figure 9-1. TPS6594-Q1 and LP8764-Q1 Digital Connections

Table 9-1. Combined MCU and Main Voltage Domain Power Rail Mapping

TYPES	VOLTAGE [V]	DOMAIN NAMES	DOMAIN TYPES	POWER RAILS	#
Digital IO	3.3	(VDDSHV0_MCU, VDDSHV1_MCU, VDDSHV2_MCU, VDDSHV0, VDDSHV2, VDDSHV5 ⁽³⁾ ⁽¹⁾ , VDDA_3P3_USB ⁽⁴⁾)	VDDSHVn_MCU, VDDSHVn, VDDA_3P3_USB ⁽¹⁾	VDD_IO_3V3	1
Digital IO	1.8	(VDDSHV0_MCU, VDDSHV1_MCU, VDDSHV2_MCU, VDDSHV0, VDDSHV2, VDDSHV5 ⁽³⁾ ⁽²⁾ , VDDS_MMC0)	VDDSHVn_MCU3, VDDSHVn ⁽²⁾ , ⁽³⁾	VDD_IO_1V8	2
Analog PHY	1.8	(VDDA_MCU_PLLGRP0, VDDA_MCU_TEMP, VDDA_ADC_MCU, VDDA_POR_WKUP, VDDA_WKUP, VDDA_OSC1, VDDA_PLLGRP8,6,4,0, VDDA_TEMP1:0) ⁽⁵⁾ , VDDA_1P8_USB, VDDA_1P8_SERDES) ⁽⁶⁾	VDDA_1P8_<clk/meas> ⁽⁵⁾ , VDDA_1P8_<phy> ⁽⁶⁾	VDA_LN_1V8 ⁽⁶⁾ , ⁽⁷⁾	3
Analog, low voltage	0.80	(VDDA_0P8_PLL_DDR, VDDA_0P8_DLL_MMC0) ⁽⁷⁾	VDDA_0P8_DPLL	VDA_DPLL_0V8	4
Digital, AVS low voltage	0.77 – 0.84	VDD_CPU	VDD_CPU	VDD_CPU_AVS	5
Digital, low voltage	0.80	VDD_MCU9, VDD_MCU_WAKE1, VDD_CORE, VDD_WAKE0, (VDDA_0P8_SERDES, VDDA_0P8_USB)	VDD_MCU, VDD_CORE, VDDA_0P8_<phy>	VDD_CORE_0V8	6
Digital, low voltage	0.85	VDDAR_MCU, VDDAR_CORE, VDDAR_CPU	VDDAR	VDD_RAM_0V85	7
Digital, low voltage	1.1	VDDS_DDR_BIAS, VDDS_DDR, VDDS_DDR_C	VDDS_DDR	VDD_DDR_1V1	8

- (1) Any MCU or Main dual voltage IO domains (VDDSHVn_MCU or VDDSHVn) being supplied by 3.3V to support 3.3V digital interfaces
- (2) Any MCU or Main dual voltage IO domains (VDDSHVn_MCU or VDDSHVn) being supplied by 1.8V to support 1.8V digital interfaces
- (3) VDDSHV5 supports MMC1 signaling for SD memory cards. A dual voltage (3.3/1.8V) power rail is required for compliant, high-speed SD card operations. If SD card is not needed or standard data rates with fixed 3.3V operation is acceptable, then domain can be grouped with digital IO 3.3V power rail. If a SD card is capable of operating with fixed 1.8V, then domain can be grouped with digital IO 1.8V power rail.
- (4) VDDA_3P3_USB is 3.3V analog domain used for USB 2.0 differential interface signaling. A low noise, analog supply is recommended to provide best signal integrity for USB data eye mask compliance. If USB interface is not needed or data bit errors can be tolerated, then domain can be grouped with 3.3V digital IO power rail either directly or through a supply filter.
- (5) VDDA_1P8_<clk/pll/ana> are 1.8V analog domains supporting clock oscillator, PLL and analog circuitry needing a low noise supply for optimal performance. It is not recommended to combine digital VDDSHVn_MCU and VDDSHVn IO domains since high frequency switching noise could negatively impact jitter performance of clock, PLL and DLL signals. Combining analog VDDA_1p8_<phy> domains should be avoided but if grouped, then in-line ferrite bead supply filtering is required.
- (6) VDDA_1P8_<phy> are 1.8V analog domains supporting multiple serial PHY interfaces. A low noise, analog supply is recommended to provide best signal integrity, interface performance and spec compliance. If any of these interfaces are not needed, data bit errors or non-compliant operation can be tolerated, then domains can be grouped with digital IO 1.8V power rail either directly or through an in-line supply filter is allowed.
- (7) VDDA_0P8_<dll/pll> are 0.8V analog domains supporting PLL and DLL circuitry needing a low noise supply for optimal performance. It is not recommended to combine these domains with any other 0.8V domains since high frequency switching noise could negatively impact jitter performance of PLL and DLL signals.

Table 9-2. Independent MCU and Main Voltage Domain Power Rail Mapping

TYPES	VOLTAGE [V]	DOMAIN NAMES	DOMAIN GROUPS	POWER RAILS	#
Digital IO	3.3	(VDDSHV0_MCU, VDDSHV1_MCU, VDDSHV2_MCU) ¹	VDDSHVn_MCU	VDD_MCUIO_3V3	1
Digital IO	3.3	(VDDSHV0, VDDSHV2, VDDSHV5) ³ 2, VDDA_3P3_USB ⁴	VDDSHVn, VDDA_3P3_USB ¹	VDD_IO_3V3	2
Digital IO	1.8	(VDDSHV0_MCU, VDDSHV1_MCU, VDDSHV2_MCU) ²	VDDSHVn_MCU ²	VDD_MCUIO_1V8	3
Digital IO	1.8	(VDDSHV0, VDDSHV2, VDDSHV5) ³ 2, VDDS_MMC0	VDDSHVn ^{2 3}	VDD_IO_1V8	4
Analog Clk, Meas	1.8	(VDDA_MCU_PLLGRP0, VDDA_MCU_TEMP, VDDA_ADC_MCU, VDDA_POR_WKUP, VDDA_WKUP) ²	VDDA_MCU1P8_<clk/meas>	VDA_MCU_1V8	5
Analog Clk, Meas	1.8	VDDA_OSC1, VDDA_PLLGRP8,6,4,0, VDDA_TEMP1:0	VDDA_1P8_<clk/meas>	VDA_PLL_1V8	6
Analog PHY	1.8	(VDDA_1P8_USB, VDDA_1P8_SERDES) ⁶	VDDA_1P8_<phy> ⁶	VDA_PHY_1V8 ⁷	7
Analog, low voltage	0.80	(VDDA_0P8_PLL_DDR, VDDA_0P8_DLL_MMC0) ⁷	VDDA_0P8_DPLL	VDA_DLL_0V8	8
Digital, low voltage	0.85	VDD_MCU ⁸ , VDD_MCU_WAKE1, VDDAR_MCU	VDD_MCU VDDAR_MCU	VDD_MCU_0V8	
Digital, AVS low voltage	0.77 – 0.84	VDD_CPU	VDD_CPU	VDD_CPU_AVS	9
Digital, low voltage	0.80	VDD_CORE, VDD_WAKE0, (VDDA_0P8_SERDES, VDDA_0P8_USB)	VDD_CORE VDDA_0P8_<phy>	VDD_CORE_0V8	10
Digital, low voltage	0.85	VDDAR_CORE, VDDAR_CPU	VDDAR	VDD_RAM_0V85	11
Digital, low voltage	1.1	VDDS_DDR_BIAS, VDDS_DDR, VDDS_DDR_C	VDDS_DDR	VDD_DDR_1V1	12

- Any MCU or Main dual voltage IO domains (VDDSHVn_MCU or VDDSHVn) being supplied by 3.3V to support 3.3V digital interfaces
- Any MCU or Main dual voltage IO domains (VDDSHVn_MCU or VDDSHVn) being supplied by 1.8V to support 1.8V digital interfaces
- VDDSHV5 supports MMC1 signaling for SD memory cards. A dual voltage (3.3/1.8V) power rail is required for compliant, high-speed SD card operations. If SD card is not needed or standard data rates with fixed 3.3V operation is acceptable, then domain can be grouped with digital IO 3.3V power rail. If a SD card is capable of operating with fixed 1.8V, then domain can be grouped with digital IO 1.8V power rail.
- VDDA_3P3_USB is 3.3V analog domain used for USB 2.0 differential interface signaling. A low noise, analog supply is recommended to provide best signal integrity for USB data eye mask compliance. If USB interface is not needed or data bit errors can be tolerated, then domain can be grouped with 3.3V digital IO power rail either directly or through a supply filter.
- VDDA_1P8_<clk/pll/ana> are 1.8V analog domains supporting clock oscillator, PLL and analog circuitry needing a low noise supply for optimal performance. It is not recommended to combine digital VDDSHVn_MCU and VDDSHVn IO domains since high frequency switching noise could negatively impact

jitter performance of clock, PLL and DLL signals. Combining analog VDDA_1p8_<phy> domains should be avoided but if grouped, then in-line ferrite bead supply filtering is required.

6. VDDA_1P8_<phy> are 1.8V analog domains supporting multiple serial PHY interfaces. A low noise, analog supply is recommended to provide best signal integrity, interface performance and spec compliance. If any of these interfaces are not needed, data bit errors or non-compliant operation can be tolerated, then domains can be grouped with digital IO 1.8V power rail either directly or through an in-line supply filter is allowed.
7. VDDA_0P8_<dll/pll> are 0.8V analog domains supporting PLL and DLL circuitry needing a low noise supply for optimal performance. It is not recommended to combine these domains with any other 0.8V domains since high frequency switching noise could negatively impact jitter performance of PLL and DLL signals.
8. VDD_MCU is a digital voltage domain with a wide range enabling it to be grouped and ramped-up with either 0.8V VDD_CORE or 0.85V RAM array (VDDAR_<xxx>) domains.

9.2 Device Connection and Layout Fundamentals

9.2.1 Power Supply Decoupling and Bulk Capacitors

9.2.1.1 Power Distribution Network Implementation Guidance

The [Sitara Processor Power Distribution Networks: Implementation and Analysis](#) provides guidance for successful implementation of the power distribution network. This includes PCB stackup guidance as well as guidance for optimizing the selection and placement of the decoupling capacitors. TI supports *only* designs that follow the board design guidelines contained in the application report.

9.2.2 External Oscillator

For more information about External Oscillators, see [Section 7.9.4, Clock Specifications](#)

9.2.3 JTAG and EMU

Texas Instruments supports a variety of eXtended Development System (XDS) JTAG controllers with various debug capabilities beyond only JTAG support. A summary of this information is available in the [XDS Target Connection Guide](#).

For more recommendations on EMU routing, see [Emulation and Trace Headers Technical Reference Manual](#)

9.2.4 Reset

The device incorporates four external reset pins (MCU_PORz, MCU_RESETz, PORz, and RESET_REQz) and two reset status pins (MCU_RESETSTATz and RESETSTATz). These pins can be driven by an external power good circuitry or Power Management IC (PMIC). MCU_PORz and Main PORz pins should be held active low during the entire power-up phase, and until all power supplies as well as the HFOSC0 clock are stable.

All MCU domain resets act as master resets to the whole device, whereas Main domain resets only reset Main domain (MCU domain is reset isolated from all Main domain resets).

9.2.5 Unused Pins

For more information about Unused Pins, see [Section 6.5, Connections for Unused Pins](#)

9.2.6 Hardware Design Guide for Jacinto™ 7 Devices

The Hardware Design Guide for Jacinto™ 7 Devices document describes hardware system design considerations for the Jacinto™ 7 family of processors. This design guide is intended to be used as an aid during the development of application hardware.

9.3 Peripheral- and Interface-Specific Design Information

9.3.1 LPDDR4 Board Design and Layout Guidelines

The goal of the [Jacinto 7 DDR Board Design and Layout Guidelines](#) is to make the LPDDR4 system implementation straightforward for all designers. Requirements have been distilled down to a set of layout and routing rules that allow designers to successfully implement a robust design for the topologies that TI supports. TI only supports board designs using LPDDR4 memories that follow the guidelines in this document.

9.3.2 OSPI and QSPI Board Design and Layout Guidelines

The following section details the routing guidelines that must be observed when routing the OSPI and QSPI interfaces.

9.3.2.1 No Loopback and Internal Pad Loopback

- The MCU_OSPI[x]_CLK output signal must be connected to the CLK pin of the flash device
- The signal propagation delay from the MCU_OSPI[x]_CLK signal to the flash device must be < 450 ps (~ 7 cm as stripline or ~ 8 cm as microstrip)
- $50\ \Omega$ PCB routing is recommended along with series terminations, as shown in [Figure 9-2](#)
- Propagation delays and matching:
 - A to B < 450 ps
 - Matching skew: < 60 ps

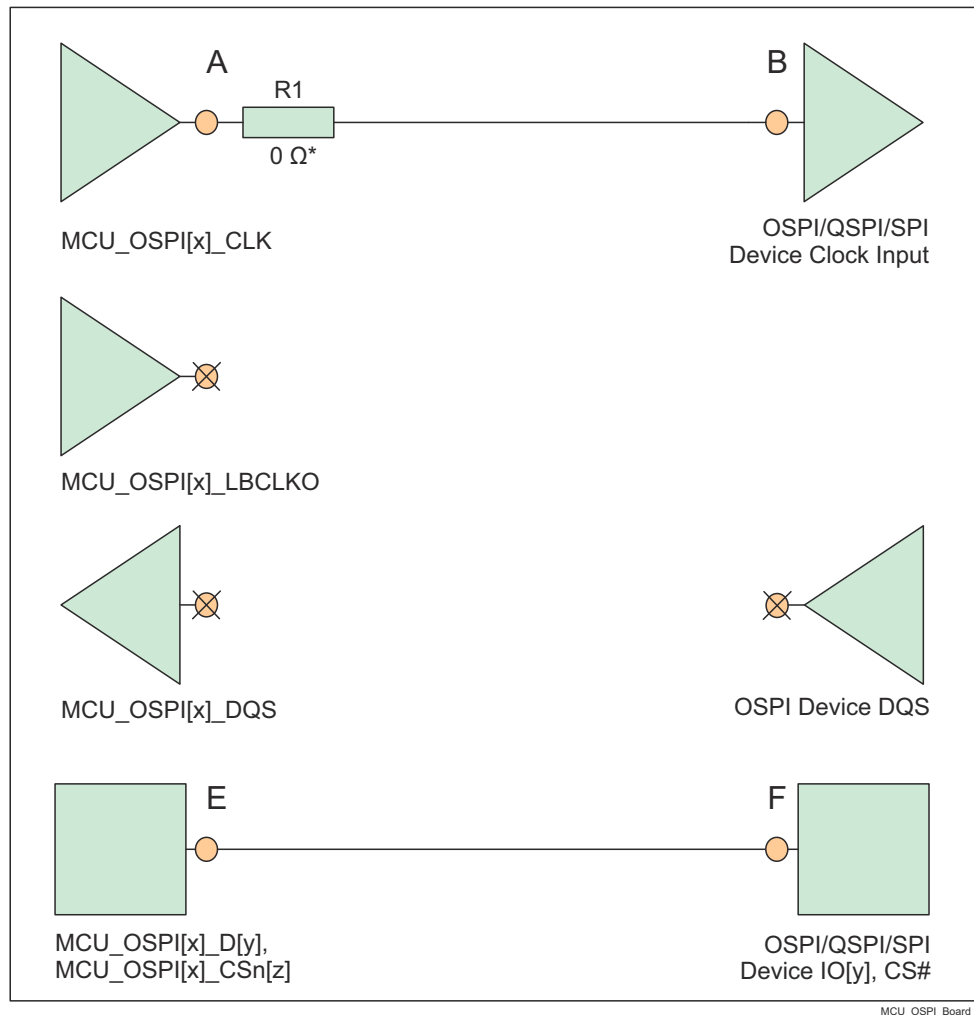

* $0\ \Omega$ resistor (R1), located as close as possible to the MCU_OSPI[x]_CLK pin, is placeholder for fine tuning, if needed.

Figure 9-2. OSPI Interface High Level Schematic

9.3.2.2 External Board Loopback

- The MCU_OSPI[x]_CLK output signal must be connected to the CLK pin of the flash device
- The MCU_OSPI[x]_LBCLKO output signal must be looped back into the MCU_OSPI[x]_DQS input
- The signal propagation delay from the MCU_OSPI[x]_CLK pin to the flash device CLK input pin (A to B) should be approximately equal to half of the signal propagation delay from the MCU_OSPI[x]_LBCLKO pin to the MCU_OSPI[x]_DQS pin ((C to D)/2). See the note below.

- The signal propagation delay from the MCU_OSPI[x]_CLK pin to the flash device CLK input pin (A to B) must be approximately equal to the signal propagation delay of the control and data signals between the flash device and the SoC device (E to F, or F to E)
- 50 Ω PCB routing is recommended along with series terminations, as shown in [Figure 9-3](#)
- Propagation delays and matching:
 - A to B = E to F = (C to D) / 2
 - Matching skew: < 60 ps

Note

The OSPI Board Loopback Hold time requirement (described in [Section 7.9.5.18, OSPI](#)) is larger than the Hold time provided by a typical flash device. Therefore, the length of MCU_OSPI[x]_LBCLKO pin to the MCU_OSPI[x]_DQS pin (C to D) can be shortened to compensate.

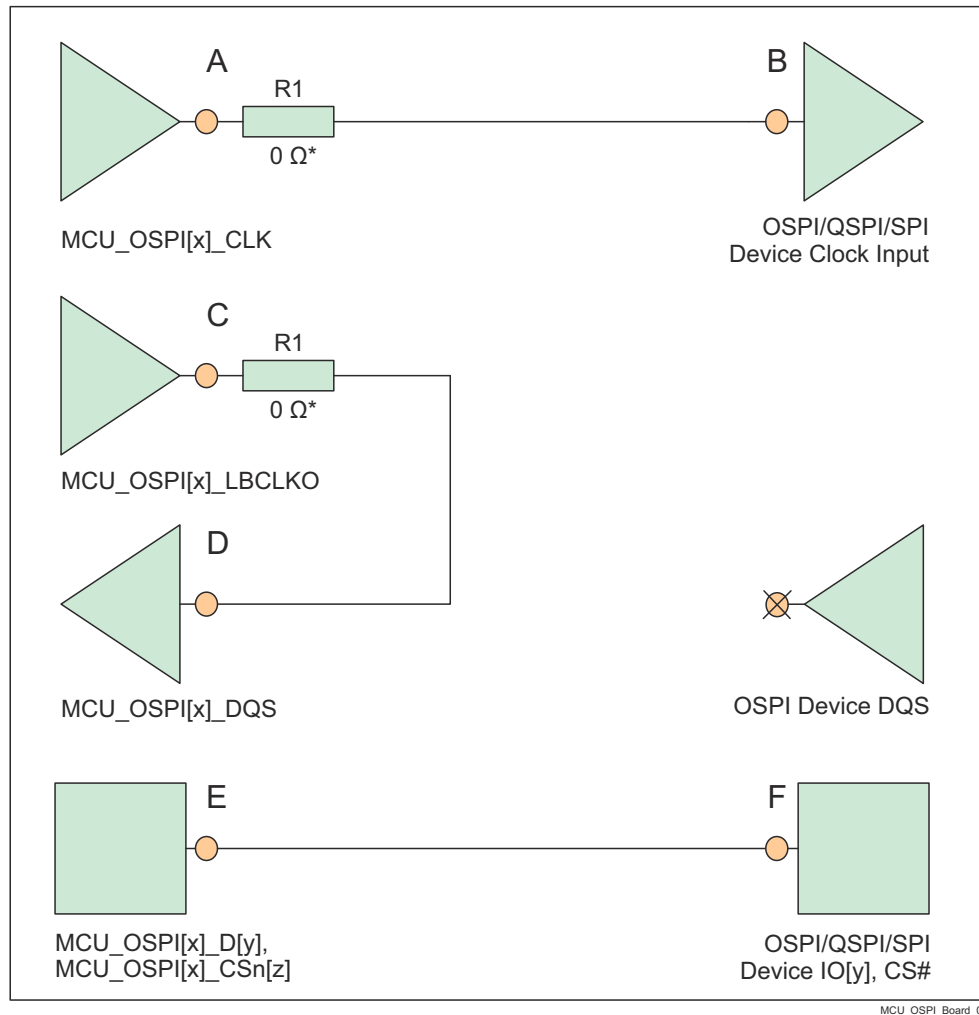

* 0 Ω resistor (R1), located as close as possible to the MCU_OSPI[x]_CLK and MCU_OSPI[x]_LBCLKO pins, is a placeholder for fine tuning, if needed.

Figure 9-3. OSPI Interface High Level Schematic

9.3.2.3 DQS (only available in Octal Flash devices)

- The MCU_OSPI[x]_CLK output signal must be connected to the CLK pin of the flash device
- The DQS pin of the flash devices must be connected to MCU_OSPI[x]_DQS signal

- The signal propagation delay from the MCU_OSPI[x]_CLK pin to the flash device CLK input pin (A to B) should be approximately equal to the signal propagation delay from the MCU_OSPI[x]_DQS pin to the DQS output pin (C to D)
- 50 Ω PCB routing is recommended along with series terminations, as shown in [Figure 9-4](#)
- Propagation delays and matching:
 - A to B = C to D
 - Matching skew: < 60 ps

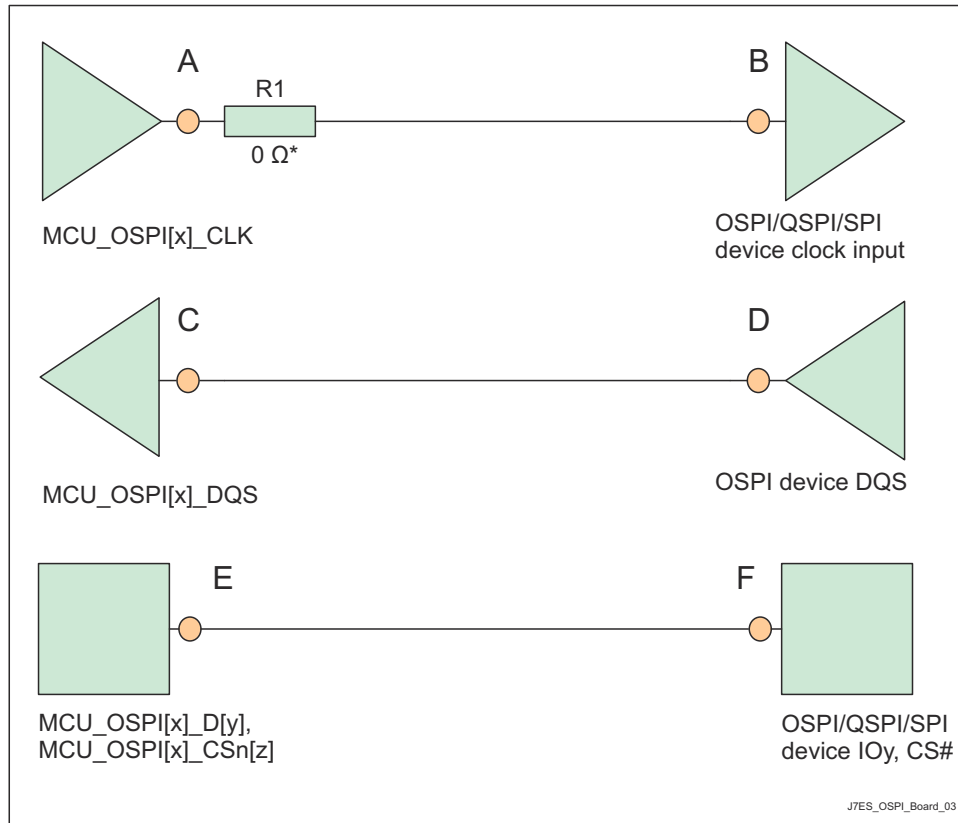

* 0 Ω resistor (R1), located as close as possible to the MCU_OSPI[x]_CLK pin, is a placeholder for fine tuning, if needed.

Figure 9-4. OSPI Interface High Level Schematic

9.3.3 USB VBUS Design Guidelines

The USB 3.1 specification allows the VBUS voltage to be as high as 5.5 V for normal operation, and as high as 20 V when the Power Delivery addendum is supported. Some automotive applications require a max voltage to be 30 V.

The device requires the VBUS signal voltage be scaled down using an external resistor divider (as shown in the [Figure 9-5](#)), which limits the voltage applied to the actual device pin (USB0_VBUS). The tolerance of these external resistors should be equal to or less than 1%, and the leakage current of zener diode at 5 V should be less than 100 nA.⁽¹⁾

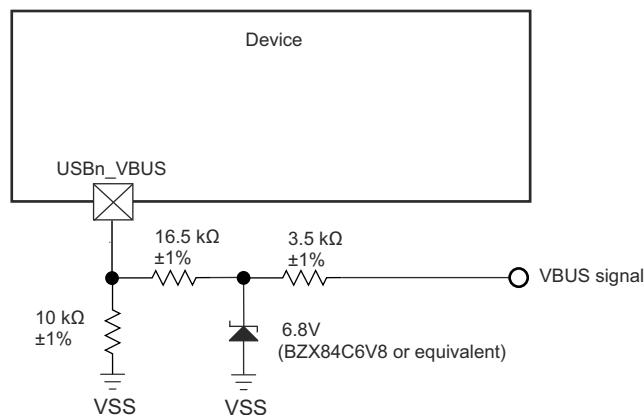

J7ES_USB_VBUS_01

Figure 9-5. USB VBUS Detect Voltage Divider / Clamp Circuit

The USB0_VBUS pin can be considered to be fail-safe because the external circuit in [Figure 9-5](#) limits the input current to the actual device pin in a case where VBUS is applied while the device is powered off.

9.3.4 System Power Supply Monitor Design Guidelines

The VMON1_ER_VSYS pin provides a way to monitor a system power supply. This system power supply is typically a single pre-regulated power source for the entire system. This supply is monitored by comparing the output of an external voltage divider circuit sourced by this supply with an internal voltage reference, with a power fail event being triggered when the voltage applied to VMON1_ER_VSYS drops below the internal reference voltage. The actual system power supply voltage trip point is determined by the system designer when selecting component values used to implement the external resistor voltage divider circuit. When designing the resistor divider circuit it is important to understand various factors which contribute to variability in the system power supply monitor trip point. The first thing to consider is the initial accuracy of the VMON1_ER_VSYS input threshold which has a nominal value of 0.45 V, with a variation of $\pm 3\%$. Precision 1% resistors with similar thermal coefficient are recommended for implementing the resistor voltage divider. This minimizes variability contributed by resistor value tolerances. Input leakage current associated with VMON1_ER_VSYS must also be considered since any current flowing into the pin creates a loading error on the voltage divider output. The VMON1_ER_VSYS input leakage current may be in the range of 10 nA to 2.5 μ A when applying 0.45 V.

Note

The resistor voltage divider shall be designed such that its output voltage never exceeds the maximum value defined in [Section 7.3, Recommended Operating Conditions](#) during normal operating conditions.

[Figure 9-6](#) presents an example, where the system power supply is nominally 5 V and the maximum trigger threshold is 5 V - 10%, or 4.5 V.

For this example, it is important to understand which variables effect the maximum trigger threshold when selecting resistor values. It is obvious a device which has a VMON1_ER_VSYS input threshold of 0.45 V + 3% needs to be considered when trying to design a voltage divider that doesn't trip until the system supply drops 10%. The effect of resistor tolerance and input leakage also needs to be considered, but how these contributions effect the maximum trigger point may not be obvious. When selecting component values which produce a maximum trigger voltage, the system designer must consider a condition where the value of R1 is 1% low and the value of R2 is 1% high combined with a condition where input leakage current for the VMON1_ER_VSYS pin is 2.5 μ A. When implementing a resistor divider where R1 = 4.81 K Ω and R2 = 40.2 K Ω , the result is a maximum trigger threshold of 4.523 V.

Once component values have been selected to satisfy the maximum trigger voltage as described above, the system designer can determine the minimum trigger voltage by calculating the applied voltage that produces an output voltage of 0.45 V - 3% when the value of R1 is 1% high and the value of R2 is 1% low, and the input

leakage current is 10 nA, or zero. Using an input leakage of zero with the resistor values given above, the result is a minimum trigger threshold of 4.008 V.

This example demonstrates a system power supply voltage trip point that ranges from 4.008 V to 4.523 V. Approximately 250 mV of this range is introduced by VMON1_ER_VSYS input threshold accuracy of $\pm 3\%$, approximately 150 mV of this range is introduced by resistor tolerance of $\pm 1\%$, and approximately 100 mV of this range is introduced by loading error when VMON1_ER_VSYS input leakage current is 2.5 μA .

The resistor values selected in this example produces approximately 100 μA of bias current through the resistor divider when the system supply is 4.5 V. The 100 mV of loading error mentioned above could be reduced to about 10 mV by increasing the bias current through the resistor divider to approximately 1 mA. So resistor divider bias current vs loading error is something the system designer needs to consider when selecting component values.

The system designer should also consider implementing a noise filter on the voltage divider output since VMON1_ER_VSYS has minimum hysteresis and a high-bandwidth response to transients. This could be done by installing a capacitor across R1 as shown in [Figure 9-6](#). However, the system designer must determine the response time of this filter based on system supply noise and expected response to transient events.

[Figure 9-6](#) presents an example, when the system power supply voltage is nominally 5 V and the desired trigger threshold is -10% or 4.5 V.

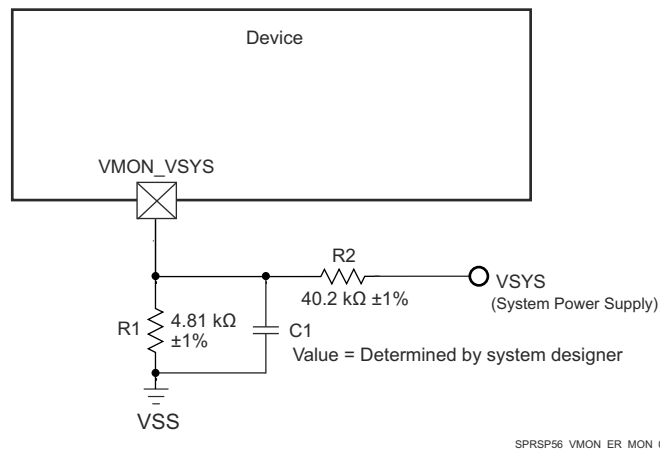

Figure 9-6. System Supply Monitor Voltage Divider Circuit

The **VMON2_IR_VCPU** pin provides a way to monitor VDD_CPU power supply. Must be externally connected as close as possible to VDD_CPU pin on the board.

The **VMON3_IR_VEXT1P8** and **VMON4_IR_VEXT1P8** pins provide a way to monitor an external 1.8V power supply. The **VMON5_IR_VEXT3P3** pin provides a way to monitor an external 3.3V power supply. An internal resistor divider with software control is implemented inside the SoC. Software can program the internal resistor divider to create appropriate under voltage and over voltage interrupts. These pins should not be sourced from an external resistor divider. If the monitored voltage requires adjustment, be sure to buffer the divided voltage prior connecting to monitor pin.

9.3.5 High Speed Differential Signal Routing Guidance

The [High Speed Interface Layout Guidelines](#) provides guidance for successful routing of the high speed differential signals. This includes PCB stackup and materials guidance as well as routing skew, length and spacing limits. TI supports *only* designs that follow the board design guidelines contained in the application report.

9.3.6 Thermal Solution Guidance

The [Thermal Design Guide for DSP and ARM Application Processors](#) provides guidance for successful implementation of a thermal solution for system designs containing this device. This document provides

background information on common terms and methods related to thermal solutions. TI only supports designs that follow system design guidelines contained in the application report.

10 Device and Documentation Support

10.1 Device Nomenclature

To designate the stages in the product development cycle, TI assigns prefixes to the part numbers of all microprocessors (MPUs) and support tools. Each device has one of three prefixes: X, P, or null (no prefix) (for example, DRA821). Texas Instruments recommends two of three possible prefix designators for its support tools: TMDX and TMDS. These prefixes represent evolutionary stages of product development from engineering prototypes (TMDX) through fully qualified production devices and tools (TMDS).

Device development evolutionary flow:

- X** Experimental device that is not necessarily representative of the final device's electrical specifications and may not use production assembly flow.
- P** Prototype device that is not necessarily the final silicon die and may not necessarily meet final electrical specifications.
- null** Production version of the silicon die that is fully qualified.

Support tool development evolutionary flow:

- TMDX** Development-support product that has not yet completed Texas Instruments internal qualification testing.
- TMDS** Fully-qualified development-support product.

X and P devices and TMDX development-support tools are shipped against the following disclaimer:

"Developmental product is intended for internal evaluation purposes."

Production devices and TMDS development-support tools have been characterized fully, and the quality and reliability of the device have been demonstrated fully. TI's standard warranty applies.

Predictions show that prototype devices (X or P) have a greater failure rate than the standard production devices. Texas Instruments recommends that these devices not be used in any production system because their expected end-use failure rate still is undefined. Only qualified production devices are to be used.

For orderable part numbers of DRA821 devices in the ALM package type, see the Package Option Addendum of this document, the TI website (ti.com), or contact your TI sales representative.

10.1.1 Standard Package Symbolization

Note

Some devices can have a cosmetic circular marking visible on the top of the device package which results from the production test process. In addition, some devices can also show a color variation in the package substrate which results from the substrate manufacturer. These differences are cosmetic only with no reliability impact.

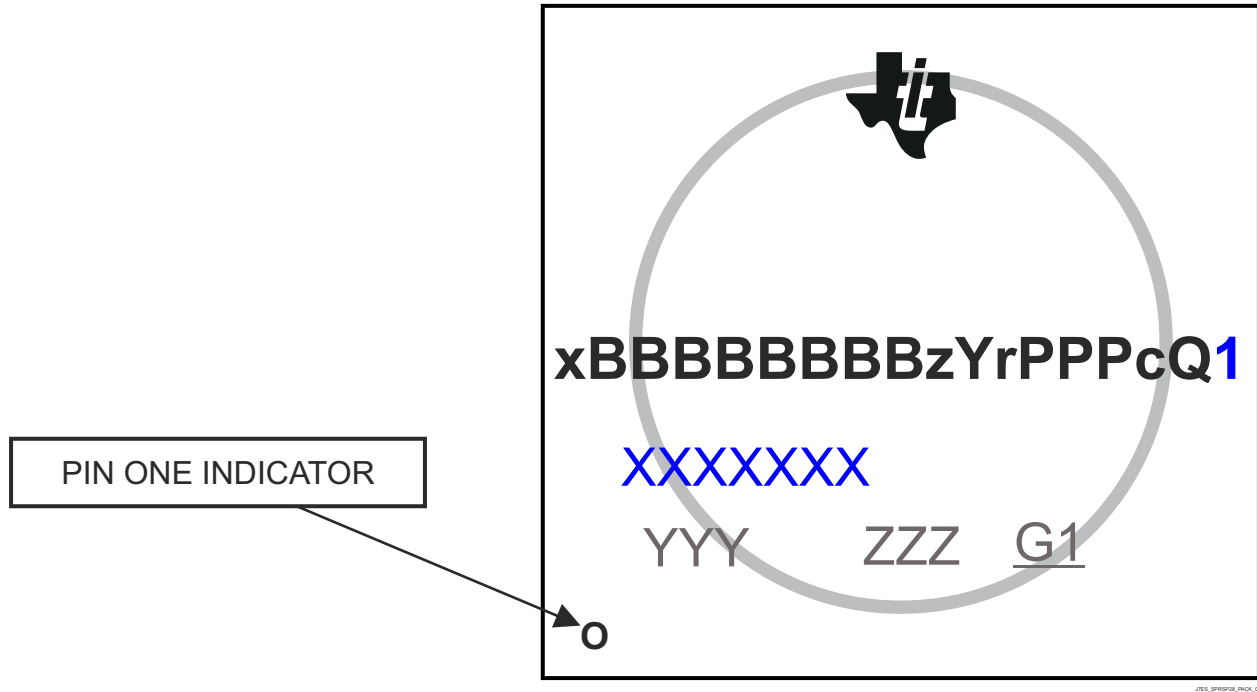

Figure 10-1. Printed Device Reference

10.1.2 Device Naming Convention

Table 10-1. Nomenclature Description

FIELD PARAMETER	FIELD DESCRIPTION	VALUE		DESCRIPTION
		MARKING	ORDERABLE	
x ⁽¹⁾	Device Evolution Stage	X		Prototype
		P		Preproduction (production test flow, no reliability data)
		BLANK		Production
BBBBBBB ⁽³⁾	Base Production Part Number	J7200		See Table 5-1, Device Comparison
		DRA821U4		
		DRA821U2		
z	Device Speed	T		See Table 7-1, Speed Grade Maximum Frequency
		L		
		E		
		C		
		OTHER		Alternate speed grade
Y	Device Type ⁽⁴⁾	G		General purpose
		C		General purpose, R5F Lockstep capable
		0		High Security capable
		5		High Security capable, R5F Lockstep capable
		R		High Security Prime ⁽⁴⁾ capable, R5F Lockstep capable
		D		High Security capable, R5F Lockstep capable, Customer Dev Keys (Preview) ⁽⁵⁾
r	Device Revision	A or BLANK		SR 1.0
		B		SR 2.0
PPP	Package Designator	ALM		ALM FCBGA-N433 (17.2 mm × 17.2 mm) Package
c	Carrier Designator	N/A	BLANK	Tray
	Carrier Designator	N/A	R	Tape and Reel
Q1 ⁽²⁾	Automotive Designator	BLANK		Not automotive qualified. Supports T _J = –40 °C to 105 °C
		Q1		Meets AEC-Q100 qualification requirements, with exceptions as specified in this document (data sheet) Supports T _J = –40 °C to 125 °C
XXXXXXX	Lot Trace Code	As Marked	N/A	Lot Trace Code (LTC)
YYY	Production Code	As Marked	N/A	Production Code; For TI use only
ZZZ	Production Code	As Marked	N/A	Production Code; For TI use only
O	Pin one	As Marked	N/A	Pin one designator
G1	ECAT	As Marked	N/A	ECAT—Green package designator

- (1) To designate the stages in the product development cycle, TI assigns prefixes to the part numbers. These prefixes represent evolutionary stages of product development from engineering prototypes through fully qualified production devices. Prototype devices are shipped against the following disclaimer:
"This product is still in development and is intended for internal evaluation purposes."
Notwithstanding any provision to the contrary, TI makes no warranty expressed, implied, or statutory, including any implied warranty of merchantability of fitness for a specific purpose, of this device.
- (2) Applies to device max junction temperature.
- (3) XJ7200GALM base part number with X speed grade indicator is the part number for the superset device. Software should constrain the features and speed used to match the intended production device.
- (4) For High Security (HS) device support, TI recommends the 0, 5 or D device types. The R and P (*High Security Prime*) device types are not recommended for most applications, as extra steps are required in the manufacturing process and, therefore, these device types are offered at a higher price point.
- (5) Only available on preproduction J7200 devices. (Advance Information/Preview)

Note

BLANK in the symbol or part number is collapsed so there are no gaps between characters.

10.2 Tools and Software

The following products support development for DRA821 platforms:

Development Tools

Code Composer Studio™ Integrated Development Environment Code Composer Studio (CCS) Integrated Development Environment (IDE) is a development environment that supports TI's Microcontroller and Embedded Processors portfolio. Code Composer Studio comprises a suite of tools used to develop and debug embedded applications. It includes an optimizing C/C++ compiler, source code editor, project build environment, debugger, profiler, and many other features. The intuitive IDE provides a single user interface taking you through each step of the application development flow. Familiar tools and interfaces allow users to get started faster than ever before. Code Composer Studio combines the advantages of the Eclipse software framework with advanced embedded debug capabilities from TI resulting in a compelling feature-rich development environment for embedded developers.

SYSCONFIG Tool System Configuration Tool: To help simplify configuration challenges and accelerate software development, TI created SysConfig, an intuitive and comprehensive collection of graphical utilities for configuring pins, peripherals, radios, subsystems, and other components. SysConfig helps you manage, expose, and resolve conflicts visually so that you have more time to create differentiated applications. The SysConfig tool is integrated in Code Composer Studio™ (CCS) IDE, as a standalone installer, or can be used via the dev.ti.com cloud tools portal.

For a complete listing of development-support tools for the processor platform, visit the Texas Instruments website at ti.com. For information on pricing and availability, contact the nearest TI field sales office or authorized distributor.

10.3 Documentation Support

To receive notification of documentation updates, navigate to the device product folder on ti.com. Click on *Subscribe to updates* to register and receive a weekly digest of any product information that has changed. For change details, review the revision history included in any revised document.

The following documents describe the DRA821 devices.

Technical Reference Manual

J7200 DRA821 Processor Silicon Revision 1.0 Texas Instruments Families of Products Technical Reference Manual Details the integration, the environment, the functional description, and the programming models for each peripheral and subsystem in the DRA821 family of devices.

Errata

J7200 DRA821 Processor Silicon Revision 1.0 Silicon Errata Describes the known exceptions to the functional specifications for the device.

10.4 Support Resources

[TI E2E™ support forums](#) are an engineer's go-to source for fast, verified answers and design help — straight from the experts. Search existing answers or ask your own question to get the quick design help you need.

Linked content is provided "AS IS" by the respective contributors. They do not constitute TI specifications and do not necessarily reflect TI's views; see TI's [Terms of Use](#).

10.5 Trademarks

I2C™ is a trademark of NXP Semiconductors.

eMMC™ is a trademark of MultiMediaCard Association.

Xccela™ is a trademark of Micron Technology, Ink.

HyperBus™ is a trademark of Mobiveil Inc.

Jacinto™, Code Composer Studio™, and TI E2E™ are trademarks of Texas Instruments.

CoreSight™ is a trademark of Arm Limited (or its subsidiaries) in the US and/or elsewhere.

Arm® and Cortex®, and are registered trademarks of Arm Limited (or its subsidiaries) in the US and/or elsewhere.

PCI-Express® is a registered trademark of PCI-SIG.

I3C® is a registered trademark of MIPI Alliance, Inc.

Secure Digital® is a registered trademark of SD Card Association.

All trademarks are the property of their respective owners.

10.6 Electrostatic Discharge Caution



This integrated circuit can be damaged by ESD. Texas Instruments recommends that all integrated circuits be handled with appropriate precautions. Failure to observe proper handling and installation procedures can cause damage.

ESD damage can range from subtle performance degradation to complete device failure. Precision integrated circuits may be more susceptible to damage because very small parametric changes could cause the device not to meet its published specifications.

10.7 Glossary

[TI Glossary](#) This glossary lists and explains terms, acronyms, and definitions.

11 Mechanical, Packaging, and Orderable Information

11.1 Packaging Information

The following pages include mechanical, packaging, and orderable information. This information is the most current data available for the designated devices. This data is subject to change without notice and revision of this document. For browser-based versions of this data sheet, refer to the left-hand navigation.

PACKAGING INFORMATION

Orderable part number	Status (1)	Material type (2)	Package Pins	Package qty Carrier	RoHS (3)	Lead finish/ Ball material (4)	MSL rating/ Peak reflow (5)	Op temp (°C)	Part marking (6)
DRA821U2CGBALM	Active	Production	FCBGA (ALM) 433	84 JEDEC TRAY (5+1)	Yes	Call TI	Level-3-260C-168 HR	-40 to 125	DRA821U2CGBALM 357 357 G1
DRA821U2CGBALM.B	Active	Production	FCBGA (ALM) 433	84 JEDEC TRAY (5+1)	Yes	Call TI	Level-3-260C-168 HR	-40 to 125	DRA821U2CGBALM 357 357 G1
DRA821U2CGBALMR	Active	Production	FCBGA (ALM) 433	500 LARGE T&R	Yes	Call TI	Level-3-260C-168 HR	-40 to 125	DRA821U2CGBALM 357 357 G1
DRA821U2CGBALMR.B	Active	Production	FCBGA (ALM) 433	500 LARGE T&R	Yes	Call TI	Level-3-260C-168 HR	-40 to 125	DRA821U2CGBALM 357 357 G1
DRA821U4TCBALMQ1	Active	Production	FCBGA (ALM) 433	84 JEDEC TRAY (5+1)	Yes	Call TI	Level-3-250C-168 HR	-40 to 125	DRA821U4TCBALMQ1 357 357 G1
DRA821U4TCBALMQ1.B	Active	Production	FCBGA (ALM) 433	84 JEDEC TRAY (5+1)	Yes	Call TI	Level-3-250C-168 HR	-40 to 125	DRA821U4TCBALMQ1 357 357 G1
DRA821U4TCBALMRQ1	Active	Production	FCBGA (ALM) 433	500 LARGE T&R	Yes	Call TI	Level-3-250C-168 HR	-40 to 125	DRA821U4TCBALMQ1 357 357 G1
DRA821U4TCBALMRQ1.B	Active	Production	FCBGA (ALM) 433	500 LARGE T&R	Yes	Call TI	Level-3-250C-168 HR	-40 to 125	DRA821U4TCBALMQ1 357 357 G1
DRA821U4TGBALM	Active	Production	FCBGA (ALM) 433	84 JEDEC TRAY (5+1)	Yes	Call TI	Level-3-260C-168 HR	-40 to 125	DRA821U4TGBALM 357 357 G1
DRA821U4TGBALM.B	Active	Production	FCBGA (ALM) 433	84 JEDEC TRAY (5+1)	Yes	Call TI	Level-3-260C-168 HR	-40 to 125	DRA821U4TGBALM 357 357 G1
DRA821U4TGBALMR	Active	Production	FCBGA (ALM) 433	500 LARGE T&R	Yes	Call TI	Level-3-260C-168 HR	-40 to 125	DRA821U4TGBALM 357 357 G1

Orderable part number	Status (1)	Material type (2)	Package Pins	Package qty Carrier	RoHS (3)	Lead finish/ Ball material (4)	MSL rating/ Peak reflow (5)	Op temp (°C)	Part marking (6)
DRA821U4TGBALMR.B	Active	Production	FCBGA (ALM) 433	500 LARGE T&R	Yes	Call TI	Level-3-260C-168 HR	-40 to 125	DRA821U4TGBALM 357 357 G1

(1) **Status:** For more details on status, see our [product life cycle](#).

(2) **Material type:** When designated, preproduction parts are prototypes/experimental devices, and are not yet approved or released for full production. Testing and final process, including without limitation quality assurance, reliability performance testing, and/or process qualification, may not yet be complete, and this item is subject to further changes or possible discontinuation. If available for ordering, purchases will be subject to an additional waiver at checkout, and are intended for early internal evaluation purposes only. These items are sold without warranties of any kind.

(3) **RoHS values:** Yes, No, RoHS Exempt. See the [TI RoHS Statement](#) for additional information and value definition.

(4) **Lead finish/Ball material:** Parts may have multiple material finish options. Finish options are separated by a vertical ruled line. Lead finish/Ball material values may wrap to two lines if the finish value exceeds the maximum column width.

(5) **MSL rating/Peak reflow:** The moisture sensitivity level ratings and peak solder (reflow) temperatures. In the event that a part has multiple moisture sensitivity ratings, only the lowest level per JEDEC standards is shown. Refer to the shipping label for the actual reflow temperature that will be used to mount the part to the printed circuit board.

(6) **Part marking:** There may be an additional marking, which relates to the logo, the lot trace code information, or the environmental category of the part.

Multiple part markings will be inside parentheses. Only one part marking contained in parentheses and separated by a "-" will appear on a part. If a line is indented then it is a continuation of the previous line and the two combined represent the entire part marking for that device.

Important Information and Disclaimer: The information provided on this page represents TI's knowledge and belief as of the date that it is provided. TI bases its knowledge and belief on information provided by third parties, and makes no representation or warranty as to the accuracy of such information. Efforts are underway to better integrate information from third parties. TI has taken and continues to take reasonable steps to provide representative and accurate information but may not have conducted destructive testing or chemical analysis on incoming materials and chemicals. TI and TI suppliers consider certain information to be proprietary, and thus CAS numbers and other limited information may not be available for release.

In no event shall TI's liability arising out of such information exceed the total purchase price of the TI part(s) at issue in this document sold by TI to Customer on an annual basis.

OTHER QUALIFIED VERSIONS OF DRA821U, DRA821U-Q1 :

● Catalog : [DRA821U](#)

● Automotive : [DRA821U-Q1](#)

NOTE: Qualified Version Definitions:

- Catalog - TI's standard catalog product
- Automotive - Q100 devices qualified for high-reliability automotive applications targeting zero defects

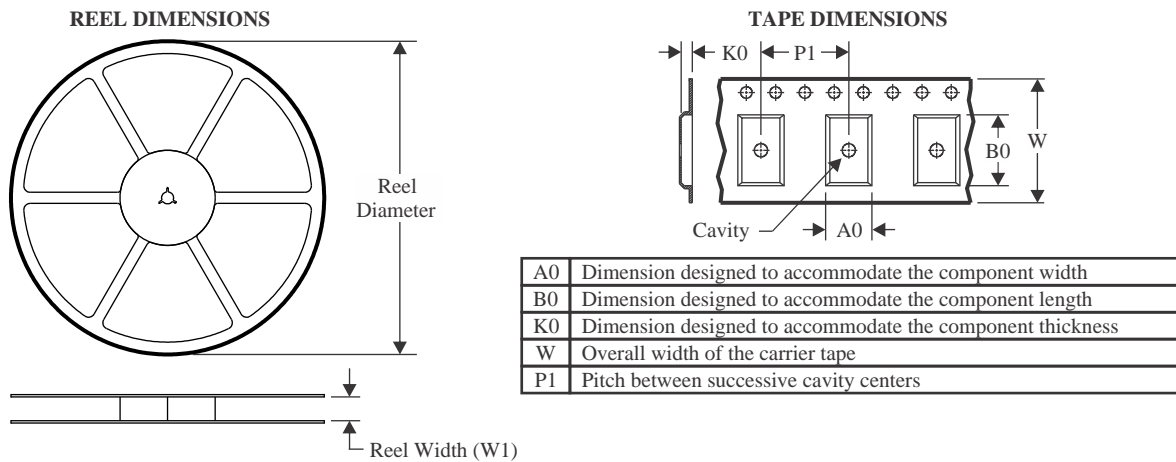
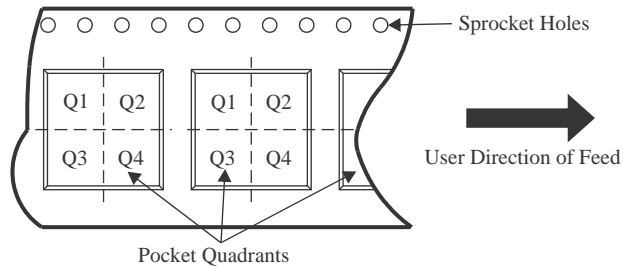
TAPE AND REEL INFORMATION

QUADRANT ASSIGNMENTS FOR PIN 1 ORIENTATION IN TAPE

*All dimensions are nominal

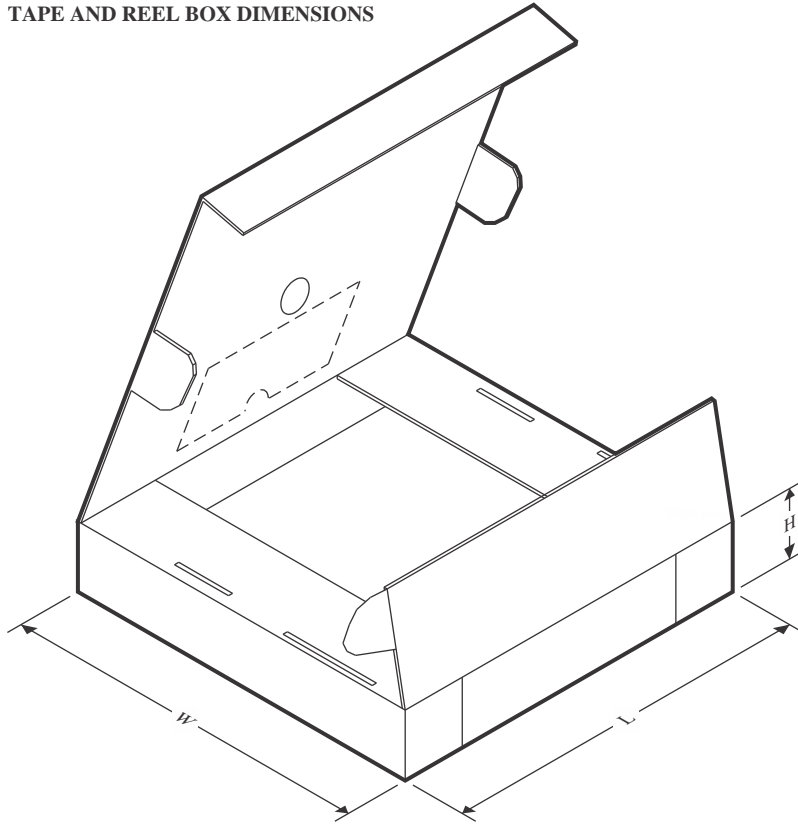
Device	Package Type	Package Drawing	Pins	SPQ	Reel Diameter (mm)	Reel Width W1 (mm)	A0 (mm)	B0 (mm)	K0 (mm)	P1 (mm)	W (mm)	Pin1 Quadrant
DRA821U2CGBALMR	FCBGA	ALM	433	500	330.0	32.4	17.6	17.6	3.74	24.0	32.0	Q1
DRA821U4TGBALMR	FCBGA	ALM	433	500	330.0	32.4	17.6	17.6	3.74	24.0	32.0	Q1

TAPE AND REEL BOX DIMENSIONS

*All dimensions are nominal

Device	Package Type	Package Drawing	Pins	SPQ	Length (mm)	Width (mm)	Height (mm)
DRA821U2CGBALMR	FCBGA	ALM	433	500	336.6	336.6	41.3
DRA821U4TGBALMR	FCBGA	ALM	433	500	336.6	336.6	41.3

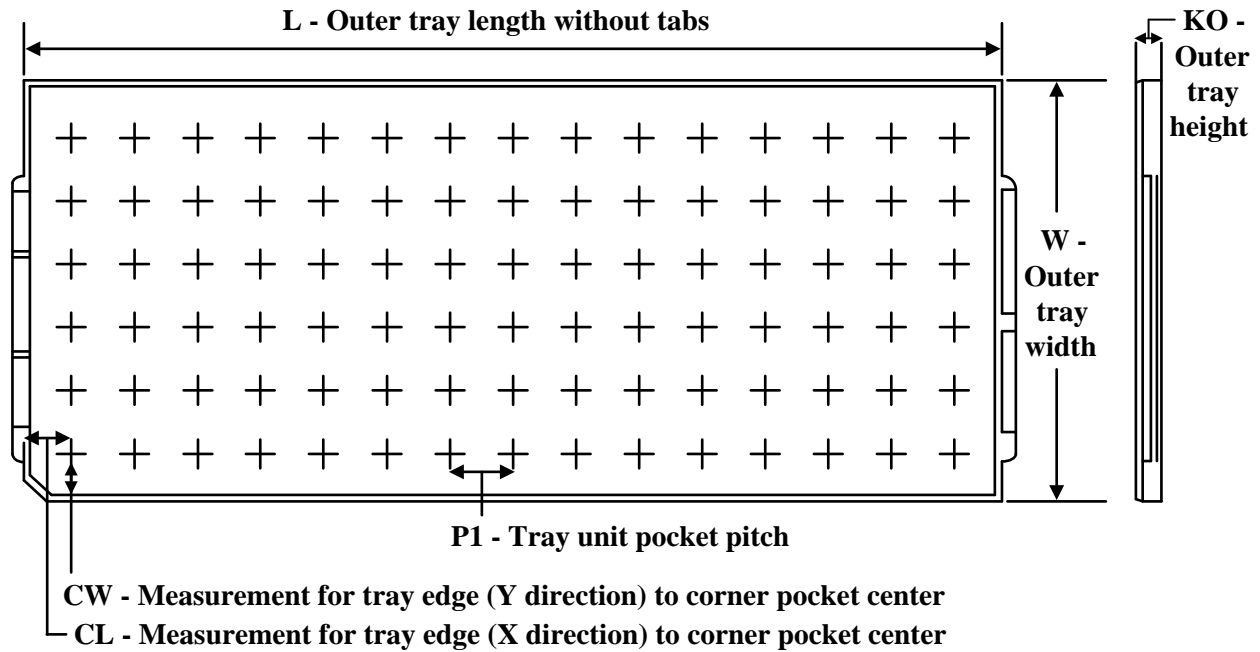
TRAY

Chamfer on Tray corner indicates Pin 1 orientation of packed units.

*All dimensions are nominal

Device	Package Name	Package Type	Pins	SPQ	Unit array matrix	Max temperature (°C)	L (mm)	W (mm)	K0 (µm)	P1 (mm)	CL (mm)	CW (mm)
DRA821U2CGBALM	ALM	FCBGA	433	84	6 X 14	150	315	135.9	7620	22	14.5	14.45
DRA821U2CGBALM.B	ALM	FCBGA	433	84	6 X 14	150	315	135.9	7620	22	14.5	14.45
DRA821U4TCBALMQ1	ALM	FCBGA	433	84	6 X 14	150	315	135.9	7620	22	14.5	14.45
DRA821U4TCBALMQ1.B	ALM	FCBGA	433	84	6 X 14	150	315	135.9	7620	22	14.5	14.45
DRA821U4TGBALM	ALM	FCBGA	433	84	6 X 14	150	315	135.9	7620	22	14.5	14.45
DRA821U4TGBALM.B	ALM	FCBGA	433	84	6 X 14	150	315	135.9	7620	22	14.5	14.45

IMPORTANT NOTICE AND DISCLAIMER

TI PROVIDES TECHNICAL AND RELIABILITY DATA (INCLUDING DATASHEETS), DESIGN RESOURCES (INCLUDING REFERENCE DESIGNS), APPLICATION OR OTHER DESIGN ADVICE, WEB TOOLS, SAFETY INFORMATION, AND OTHER RESOURCES "AS IS" AND WITH ALL FAULTS, AND DISCLAIMS ALL WARRANTIES, EXPRESS AND IMPLIED, INCLUDING WITHOUT LIMITATION ANY IMPLIED WARRANTIES OF MERCHANTABILITY, FITNESS FOR A PARTICULAR PURPOSE OR NON-INFRINGEMENT OF THIRD PARTY INTELLECTUAL PROPERTY RIGHTS.

These resources are intended for skilled developers designing with TI products. You are solely responsible for (1) selecting the appropriate TI products for your application, (2) designing, validating and testing your application, and (3) ensuring your application meets applicable standards, and any other safety, security, regulatory or other requirements.

These resources are subject to change without notice. TI grants you permission to use these resources only for development of an application that uses the TI products described in the resource. Other reproduction and display of these resources is prohibited. No license is granted to any other TI intellectual property right or to any third party intellectual property right. TI disclaims responsibility for, and you fully indemnify TI and its representatives against any claims, damages, costs, losses, and liabilities arising out of your use of these resources.

TI's products are provided subject to [TI's Terms of Sale](#), [TI's General Quality Guidelines](#), or other applicable terms available either on ti.com or provided in conjunction with such TI products. TI's provision of these resources does not expand or otherwise alter TI's applicable warranties or warranty disclaimers for TI products. Unless TI explicitly designates a product as custom or customer-specified, TI products are standard, catalog, general purpose devices.

TI objects to and rejects any additional or different terms you may propose.

Copyright © 2025, Texas Instruments Incorporated

Last updated 10/2025

Looking for pricing, stock, or lifecycle information?

Click below to explore more details on WIN SOURCE:

 [View DRA821U4TCBALMRQ1 on WIN SOURCE](#)

 [Texas Instruments](#) Information

Optimize Your Supply Chain with WIN SOURCE Solutions

-  Global Sourcing Solution
-  Obsolete Management
-  Cost Control Management
-  Shortage Management
-  Alternative Solution
-  Excess Inventory Management