

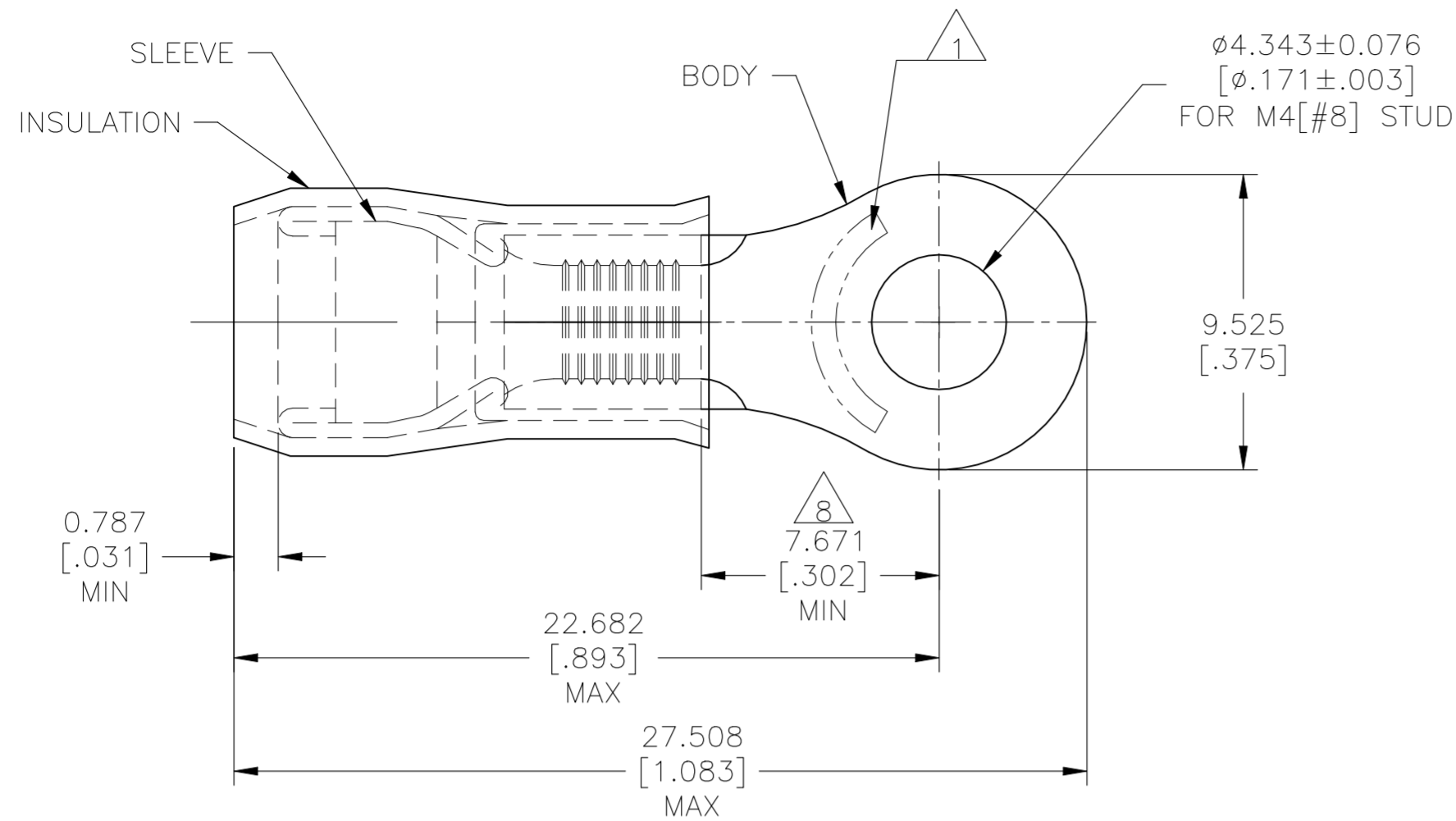

**THE DATASHEET OF
PCV-2-105-02L**



REVISIONS					
P	LTR	DESCRIPTION	DATE	DWN	APVD
U4		REVISED PER ECN-22-156403	03JUN2022	RK	CSD



STYLE "A"

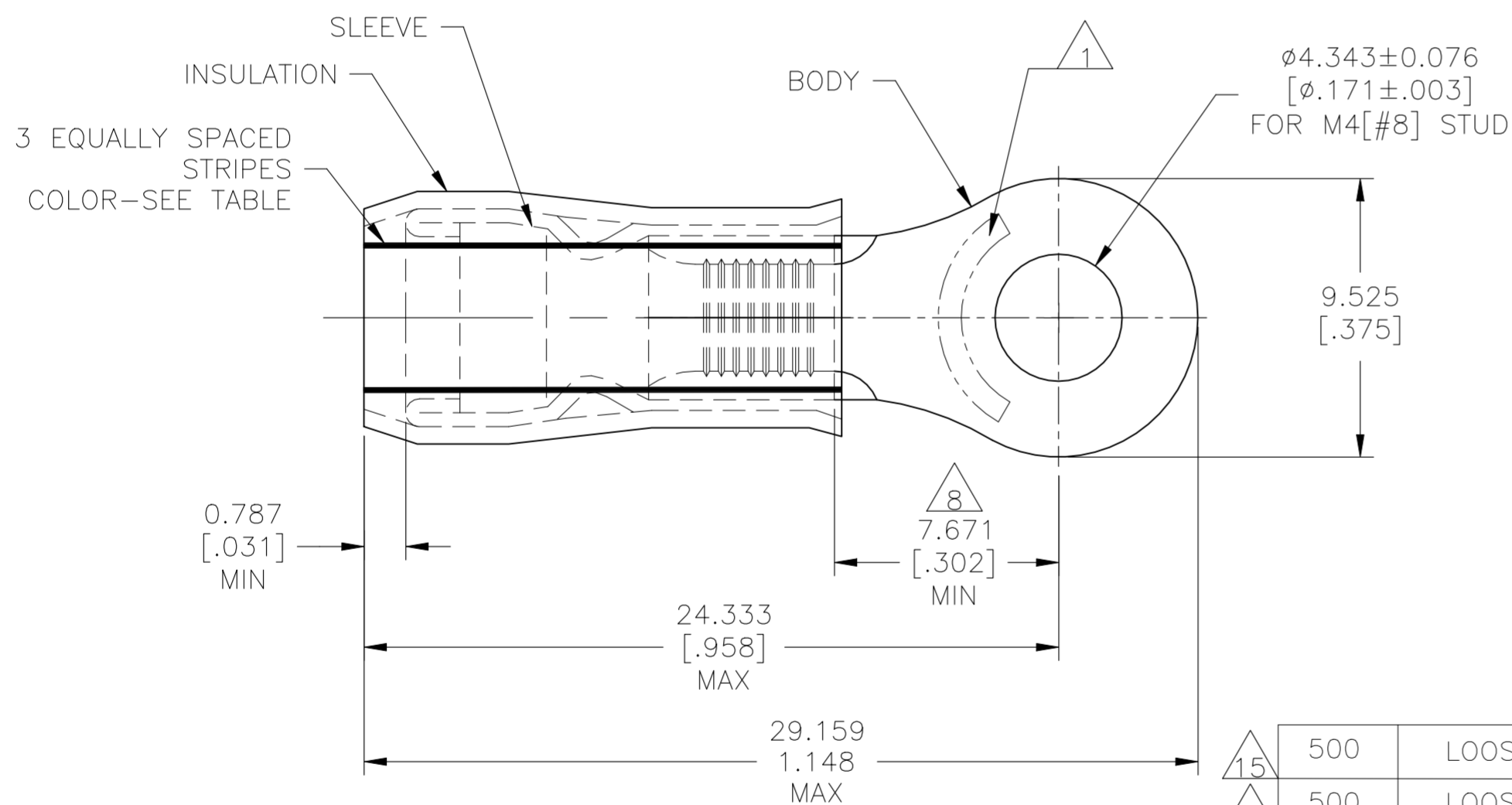

STYLE "B"
INSULATION RESTRICTING

AMP WIRE RANGE	E13288 Listed	LR7189 Certified
12-10 AWG SOLID OR STRANDED IR: STRANDED	12-10 AWG STRANDED	12-10 AWG SOLID OR STRANDED IR: STRANDED

- STAMP "AMP - SEE TABLE" APPROX AS SHOWN.
- WIRE INSULATION DIA: SEE TABLE .
- BODY MATERIAL THK: 1.016±0.051[.040±.002].
- FINISH:
BODY: TIN PLATE 0.00254[.000100] MIN EXT THK PER ASTM B545.
INSULATION: COLOR-YELLOW
- FINISH:
SLEEVE: TIN PLATE 0.00254[.000100] MIN EXT THK PER ASTM B545.
INSULATION: COLOR-YELLOW
- FINISH:
SLEEVE: NICKEL PLATE PER SAE AMS QQ-N-290.
INSULATION: COLOR-YELLOW
- MATERIAL:
BODY & SLEEVE- CU PER ASTM B152
INSULATION - NYLON PER ASTM D4066
- APPLIES FROM EDGE OF METAL WIRE BARREL TO CENTER OF STUD HOLE.
- MEETS MS25036-156, CLASS 1.
- NOTE DELETED
- MEETS M7928/1-57, CLASS 1.
- MEETS M7928/1-64, CLASS 1.
- NOTE DELETED.
- UL LISTED
- CSA CERTIFIED

	500	LOOSE PIECE	10*	3.023-5.080[.119-.200]	10	BROWN	B				2-320568-3
	500	LOOSE PIECE	12*	2.413-5.080[.095-.200]	12	YELLOW	B				2-320568-2
	2500	ON TAPE & REEL	12-10*	3.810-5.842[.150-.230]	12-10	--	A				2-320568-1
	500	LOOSE PIECE	12-10*	3.810-5.842[.150-.230]	12-10	--	A				320568
QTY	PACKAGE TYPE	STAMPING	WIRE INSUL DIA	WIRE SIZE	STRIPE COLOR	STYLE	BODY FINISH	SLEEVE FINISH	PART NO		

CUSTOMER SERVICE SYSTEMS		MAX RECOMMENDED OPERATING TEMPERATURE: 105°C[221°F] MAX	THIS DRAWING IS A CONTROLLED DOCUMENT.		DWN JR RUTH 17DEC09	TE Connectivity		
FOR ADDITIONAL PRODUCT INFORMATION OR COPIES OF DRAWINGS AND TECHNICAL DOCUMENTS	PRODUCT INFORMATION CENTER 1-800-522-6752	VOLTAGE RATING: 300 VOLT MAX	DIMENSIONS: mm [INCHES]	TOLERANCES UNLESS OTHERWISE SPECIFIED: 0 PLC ± - 1 PLC ± - 2 PLC ± - 3 PLC ± 0.127[.005] 4 PLC ± - ANGLES ± -	CHK T MICHIELUTTI 17DEC09		NAME	
FOR APPLICATION TOOLING INFORMATION	TOOLING ASSISTANCE CENTER 1-800-722-1111	CIRCULAR MIL AREA: 2.62-6.64mm²[5,180-13,100] STRANDED OR SOLID		0 PLC ± - 1 PLC ± - 2 PLC ± - 3 PLC ± 0.127[.005] 4 PLC ± - ANGLES ± -	APVD T MICHIELUTTI 17DEC09		PRODUCT SPEC UL 486 A-B	
FOR ORDER ENTRY	1-800-526-5142		MATERIAL	FINISH	APPLICATION SPEC 114-2157		SIZE A2	
					WEIGHT -	CAGE CODE 00779	DRAWING NO C=320568	RESTRICTED TO -
						SCALE 5:1	SHEET 1 of 1	REV U4

Looking for pricing, stock, or lifecycle information?

Click below to explore more details on WIN SOURCE:

 [View PCV-2-105-02L on WIN SOURCE](#)

 [Coilcraft Information](#)

Optimize Your Supply Chain with WIN SOURCE Solutions

-  Global Sourcing Solution
-  Obsolete Management
-  Cost Control Management
-  Shortage Management
-  Alternative Solution
-  Excess Inventory Management