



**THE DATASHEET OF
LY M676-Q2R2-4-0-20-R18-Z**





THE BIG DEAL

- Wideband, 2 to 18 GHz
- Low Insertion Loss, Typ. 2.0 dB
- Excellent Phase Unbalance, Typ. 2 Degrees
- Excellent Amplitude Unbalance, Typ. 0.3 dB
- Single Ended to Differential Conversion
- 3x4 mm 12-Lead QFN-Style Package

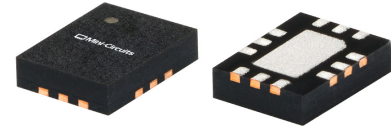

Generic photo used for illustration purposes only

APPLICATIONS

- 5G MIMO and Back Haul Radio Systems
- Test and Measurement Equipment
- Radar, EW, and ECM Defense Systems
- Signal Distribution Networks

FUNCTIONAL DIAGRAM

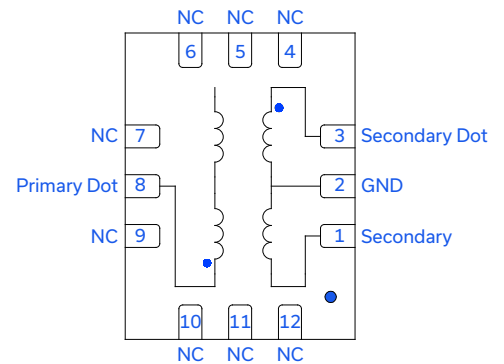

PRODUCT OVERVIEW

Mini-Circuits MTX2-183+ is a wideband MMIC balun transformer with an impedance ratio of 1:2 applicable for a wide range of applications from 2 to 18 GHz. Fabricated using GaAs process technology. The MMIC provides outstanding repeatability with low insertion loss, low amplitude unbalance, low phase unbalance, and excellent common mode rejection.

KEY FEATURES

Features	Advantages
Wideband, 2 to 18 GHz	Supports a broad variety of applications including Test and Measurement, WLAN, 5G Microwave Radio, Radar, and Electronic Warfare.
Low Insertion Loss, 2.0 dB Typ. (Above Theoretical)	Enables excellent signal power transmission from input to output.
Excellent Common Mode Rejection, 33 dB Typ.	Enables rejection of undesired signals.
3x4 mm 12-Lead QFN-Style Package	Small footprint saves space in dense layouts while providing low inductance, repeatable transitions, and excellent thermal contact to the PCB.



MMIC SURFACE MOUNT

Balun

MTX2-183+

Mini-Circuits

50Ω 2 to 18 GHz

ELECTRICAL SPECIFICATIONS¹ AT +25°C, UNLESS NOTED OTHERWISE

Parameter	Frequency (GHz)	Min.	Typ.	Max.	Units
Impedance Ratio (Secondary/Primary)			2		
Frequency Range		2		18	GHz
Average Insertion Loss (Above 3 dB Theoretical)	2-4		1.7	3.8	dB
	4-14		1.5	4.2	
	14-18		3.7	7.3	
Amplitude Unbalance	2-4		0.4	0.9	dB
	4-14		0.2	1.8	
	14-18		0.4	3.1	
Phase Unbalance ²	2-4		1	6	Degree
	4-14		2	13	
	14-18		2	10	
Common Mode Rejection Ratio (CMRR)	2-4		27		dB
	4-14		39		
	14-18		22		
Input Return Loss	2-4	4	11		dB
	4-14	5	13		
	14-18	5	17		

1. Tested in Mini-Circuits Evaluation Board TB-MTX2-183C+.

2. Relative to 180°.



TYPICAL PERFORMANCE GRAPHS

AVERAGE INSERTION LOSS VS. TEMPERATURE
ABOVE 3 dB THEORETICAL, $P_{IN} = 0$ dBm

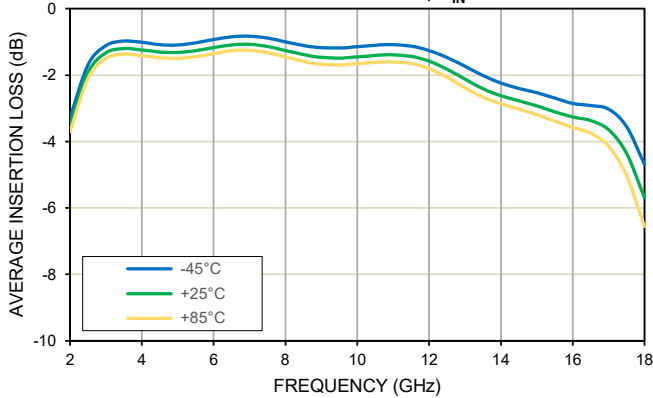

INPUT RETURN LOSS VS. TEMPERATURE
 $P_{IN} = 0$ dBm

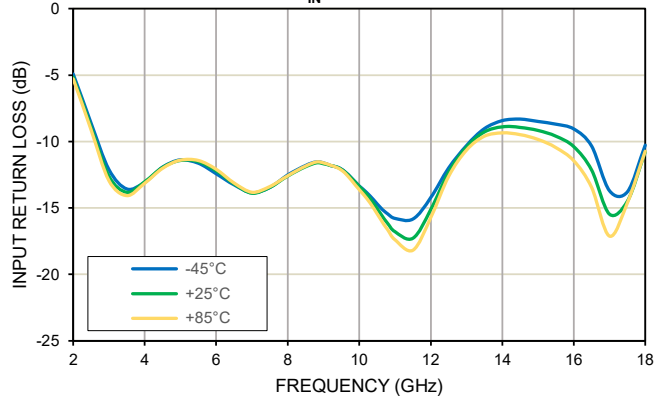

AMPLITUDE UNBALANCE VS. TEMPERATURE
 $P_{IN} = 0$ dBm

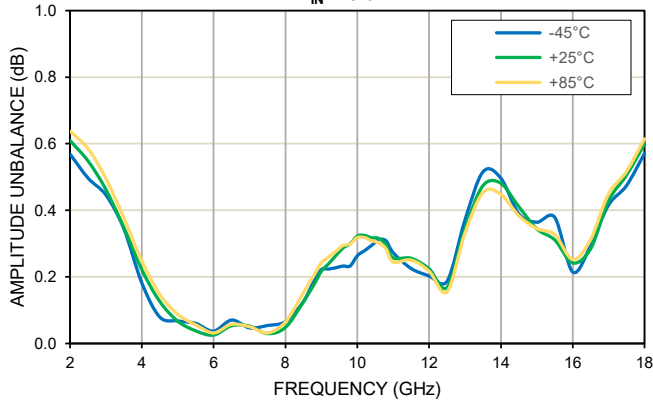

PHASE UNBALANCE VS. TEMPERATURE
RELATIVE TO 180°, $P_{IN} = 0$ dBm

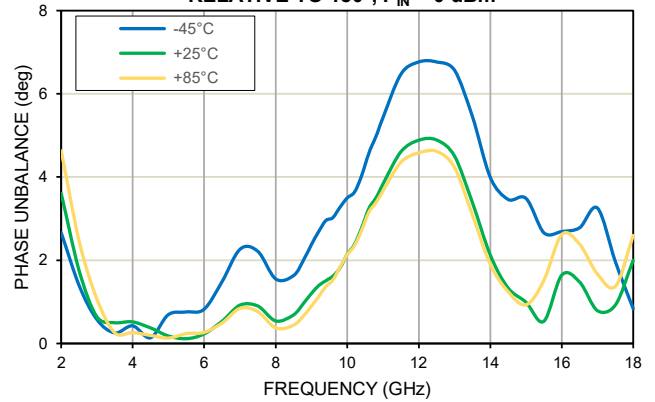

CMRR VS. TEMPERATURE
 $P_{IN} = 0$ dBm

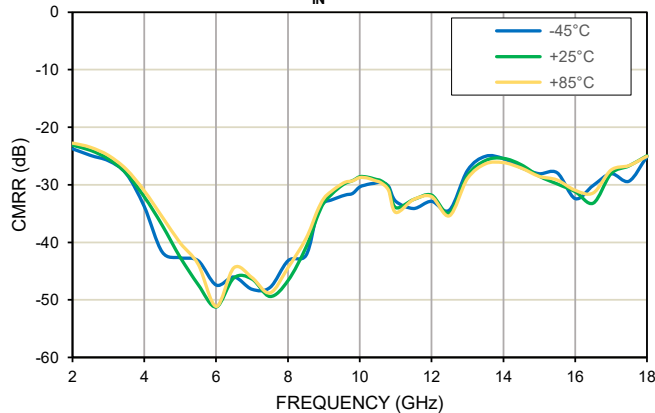

**ABSOLUTE MAXIMUM RATINGS³**

Parameter	Ratings
Operating Temperature (Ground Lead)	-45°C to +85°C
Storage Temperature	-65°C to +150°C
RF Input Power	2 W

3. Permanent damage may occur if any of these limits are exceeded.

ESD RATING

	Class	Voltage Range	Reference Standard
HBM	1C	1000 to < 2000 V	ANSI/ESDA/JEDEC JS-001-2017



ESD HANDLING PRECAUTION: This device is designed to be Class 1C for HBM. Static charges may easily produce potentials higher than this with improper handling and can discharge into DUT and damage it. As a preventive measure Industry standard ESD handling precautions should be used at all times to protect the device from ESD damage.

MSL RATING

Moisture Sensitivity: MSL1 in accordance with IPC/JEDEC J-STD-020E/JEDEC J-STD-033C



FUNCTIONAL DIAGRAM

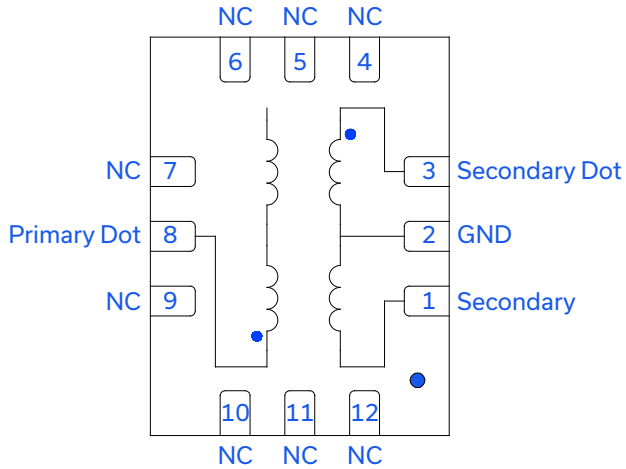

Figure 1. MTX2-183+ Functional Diagram

PAD DESCRIPTION

Function	Pad Number	Description (Refer to Fig 2)
Primary Dot	8	Common Unbalanced RF Port.
Secondary Dot	3	Balanced RF Port.
Secondary	1	Balanced RF Port.
GND	2	External ground.
NC	4-7, 9-12	No connection. Connected to ground on the test board.

EVALUATION BOARD

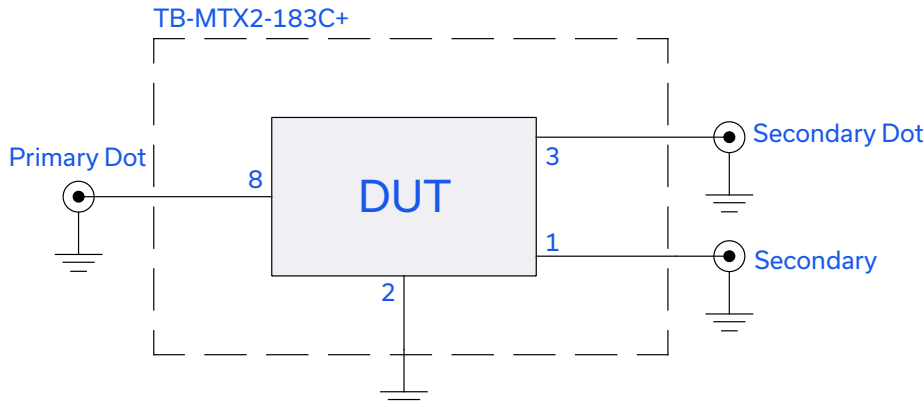

Figure 2. DUT soldered on Mini-Circuits Evaluation Board: TB-MTX2-183C+

Electrical Parameters and Conditions

Insertion Loss, Amplitude Unbalance, Phase Unbalance, Common Mode Rejection measured using N5242A PNA-X microwave network analyzer.

Conditions:
1. $P_{IN} = 0$ dBm



CASE STYLE DRAWING

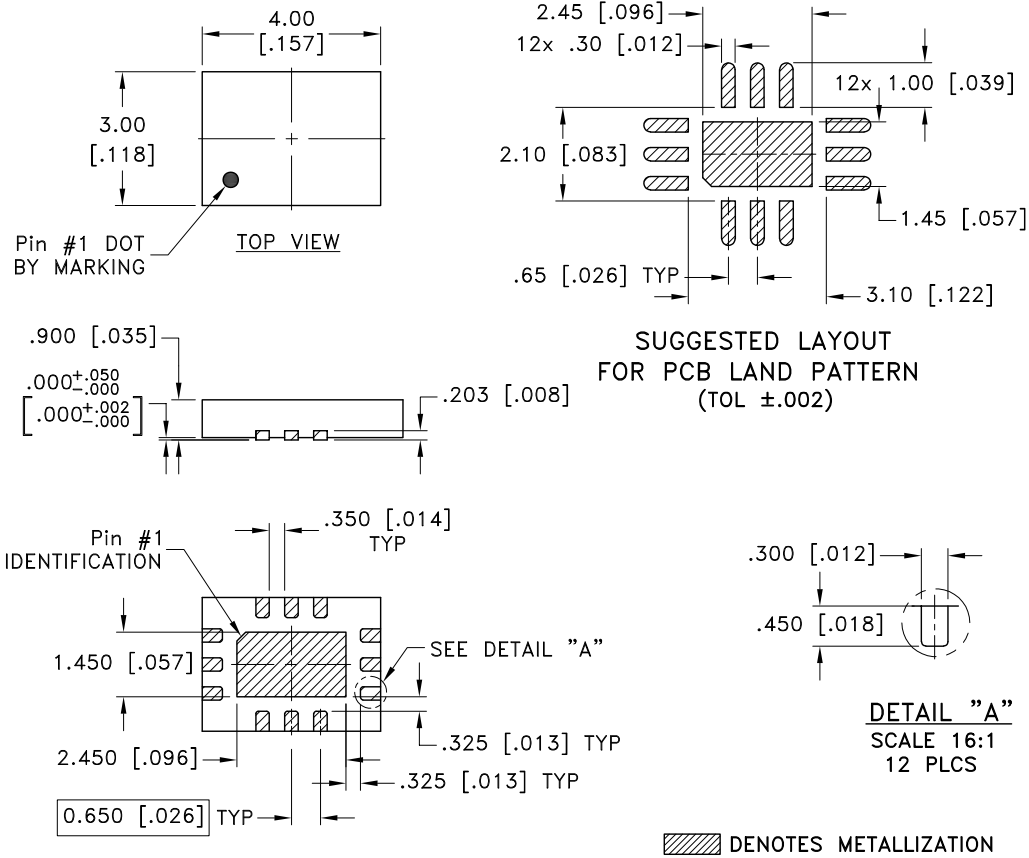

Weight: 0.032 grams
 Dimensions are in mm [inches]. Tolerances 3 Pl. ±0.05 [0.002] mm [Inch]

PRODUCT MARKING

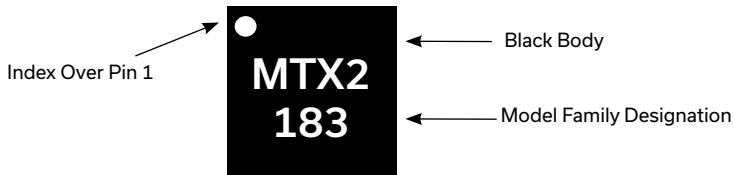

Marking may contain other features or characters for internal lot control.



MMIC SURFACE MOUNT

Balun

MTX2-183+

50Ω 2 to 18 GHz

Mini-Circuits

ADDITIONAL DETAILED INFORMATION IS AVAILABLE ON OUR DASHBOARD.

[CLICK HERE](#)

Performance Data & Graphs	Data Graphs S-Parameter (S3P Files) Data Set (.zip file)
Case Style	DG3006. Plastic package, exposed paddle, Lead Finish: ex. (Matte-Tin)
RoHS Status	Compliant
Tape & Reel Standard Quantities Available on Reel	F68 7" Reel with 20, 50, 100, 200, 500, or 1000 devices 13" Reel with 2000, 3000, or 4000 devices
Suggested Layout for PCB Design	PL-754
Evaluation Board	TB-MTX2-183C+ Gerber File
Environmental Ratings	ENV08T1

NOTES

- Performance and quality attributes and conditions not expressly stated in this specification document are intended to be excluded and do not form a part of this specification document.
- Electrical specifications and performance data contained in this specification document are based on Mini-Circuit's applicable established test performance criteria and measurement instructions.
- The parts covered by this specification document are subject to Mini-Circuits standard limited warranty and terms and conditions (collectively, "Standard Terms"); Purchasers of this part are entitled to the rights and benefits contained therein. For a full statement of the standard terms and the exclusive rights and remedies thereunder, please visit Mini-Circuits' website at www.minicircuits.com/terms/viewterm.html



Looking for pricing, stock, or lifecycle information?

Click below to explore more details on WIN SOURCE:

- ⊖ [View LY M676-Q2R2-4-0-20-R18-Z on WIN SOURCE](#)
- ⊖ [OSRAM Opto Semiconductors Inc. Information](#)

Optimize Your Supply Chain with WIN SOURCE Solutions

- ✓ Global Sourcing Solution
- ✓ Obsolete Management
- ✓ Cost Control Management
- ✓ Shortage Management
- ✓ Alternative Solution
- ✓ Excess Inventory Management