

AWR2544 Single-Chip 76-81GHz FMCW Radar SoC with Launch-On-Package (LOP) Waveguide Interface for ADAS Applications

1 Features

- FMCW transceiver
 - Integrated PLL, transmitter, receiver, baseband and ADC
 - 76 to 81GHz coverage with greater than 4GHz available bandwidth
 - 4 receive and 4 transmit channels with **Launch-on-Package (LOP) interface** to antennas
 - Per transmit phase shifter
 - Ultra-accurate chirp engine based on fractional PLL
 - TX power
 - +12.5dBm
 - RX noise figure
 - +12.5dB
 - Phase noise (@ 1MHz)
 - -96dBc/Hz (76 to 77GHz)
 - -95dBc/Hz (76 to 81GHz)
- Built-in calibration and self-test
 - Built in firmware (ROM)
 - Self-calibrating system across process and temperature
- Processing elements
 - Arm® Cortex-R5F® core (supports lock step operation) at 300MHz
 - TI radar hardware accelerator (HWA1.5) for operations like FFT, interference mitigation, and memory compression
 - Multiple EDMA instances for data movement
- Host interface
 - 10/100/1000Mbps RGMII/RMII/MII Ethernet
 - 25MHz clock output for Ethernet PHY clocking
- Supports a serial flash memory interface (loading user application from QSPI flash memory)
- Other interfaces available to user application
 - Up to 4 ADC channels
 - 1 SPI
 - 2 UARTs
 - I²C
 - GPIOs
 - 3 EPWMs
 - 2-lane LVDS interface for raw ADC data and debug instrumentation
- On-Chip RAM
 - 2MB
 - Memory space split between MCU and shared L3
- Device security (*on select part numbers*)
 - Programmable embedded hardware security module (HSM)
 - Secure authenticated and encrypted boot support
 - Customer programmable root keys, symmetric keys (256 bit), asymmetric keys (up to RSA-4K or ECC-512) with key revocation capability
 - Cryptographic hardware accelerators: PKA with ECC, AES (up to 256 bit), SHA (up to 512 bit), TRNG/DRBG
- Functional safety compliant targeted
 - Developed for functional safety applications
 - Documentation available to aid ISO26262 functional safety system design
 - Hardware integrity up to ASIL B targeted
- AEC-Q100 qualified
- Advanced features
 - Embedded self-monitoring with no external processor involvement
 - Embedded interference detection capability
- Power management
 - On-die LDO network for enhanced PSRR
 - LVCMOS IO supports dual voltage 3.3V and 1.8V
- Clock source
 - 40MHz or 50MHz crystal with internal oscillator
 - Supports external oscillator/driven clock at 40MHz or 50 MHz
- Power Management
 - Recommended LP8772-Q1 Power Management IC (PMIC)
 - Companion PMIC specially designed to meet device power supply requirements
 - Flexible mapping and factory programmed configurations to support different use cases
- Cost-reduced hardware design
 - 0.65mm pitch, 12.4mm × 12mm FCCSP package
 - Small size
- Supports automotive temperature operating range
 - Operating junction temperature range: –40°C to +140°C



2 Applications

- Lane change assist
- Blind spot detection
- Automatic emergency braking
- Adaptive cruise control
- Cross traffic alert
- Satellite

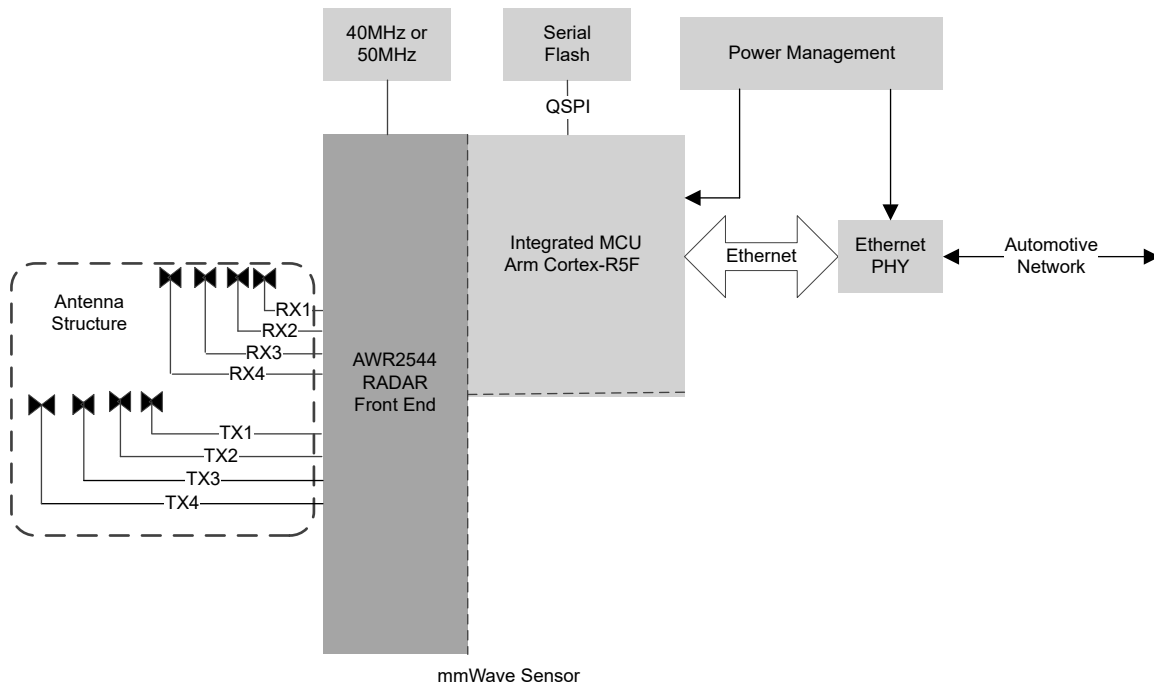

Figure 2-1. Autonomous Radar Sensor For Automotive Applications

3 Description

The AWR2544 is a single-chip mmWave sensor composed of a FMCW transceiver. The device is capable of operation in the 76 to 81GHz (EHF) band, includes radar data processing elements, and a rich set of peripherals for in-vehicle networking. AWR2544 provides customers with an additional Launch on package (LOP) antenna feature which facilitates the attachment of antennas directly on to the package. The AWR2544 is built with TI's low-power 45nm RFCMOS process and enables unprecedented levels of integration in a small form factor and minimal BOM. The AWR2544 is designed for low-power, self-monitored, ultra-accurate radar systems in the automotive space.

TI's low-power 45nm RFCMOS process enables a monolithic implementation of a 4 TX, 4 RX system with integrated PLL, VCO, mixer, and baseband ADC. The device includes a Radio Processor Subsystem (RSS), which is responsible for radar front-end configuration, control, and calibration. Within the Main Subsystem (MSS), the device implements a user-programmable Arm Cortex-R5F processor allowing for custom control and automotive interface applications. The hardware accelerator block (HWA 1.5) supplements the MSS by offloading common radar processing such as FFT, scaling, and compression. This saves MIPS on the external processor, opening up resources for custom applications and implementation of higher-level post-processing algorithms.

A Hardware Security Module (HSM) is also provisioned in the device (available for only secure part variants). The HSM consists of a programmable Arm Cortex-M4 core and the necessary infrastructure to provide a secure zone of operation within the device.

Simple programming model changes can enable a wide variety of sensor implementation (Short, Mid, Long) with the possibility of dynamic reconfiguration for implementing a multimode sensor.

TI has designed the AWR2544 specifically for satellite architecture. Satellite architecture adds value through a sensor fusion algorithm and the larger computing capability in the central ECU. Simplified satellite sensors and differentiation through software can help reduce system complexity and offer new ways of creating value.

Using satellite radars gives automakers the option to use over-the-air software updates to improve system performance and enhance security. These multiple benefits – performance, scalability and simplicity – all contribute the prominence of the satellite architecture in the automotive industry.

Additionally, the AWR2544 is provided as a complete platform including TI hardware and software reference designs, software drivers, sample configurations, API guides, and user documentation.

Device Information

PART NUMBER	PACKAGE ⁽¹⁾	BODY SIZE (NOM)	Security
AWR2544BGAMQQ1	AMQ (FCCSP, 248)	12.4mm x 12mm	General
AWR2544BGAMQRQ1	AMQ (FCCSP, 248)	12.4mm x 12mm	General
AWR2544BSAMQQ1	AMQ (FCCSP, 248)	12.4mm x 12mm	Secure
AWR2544BSAMQRQ1	AMQ (FCCSP, 248)	12.4mm x 12mm	Secure

(1) For more information, see [Section 13](#) , .

3.1 Functional Block Diagram

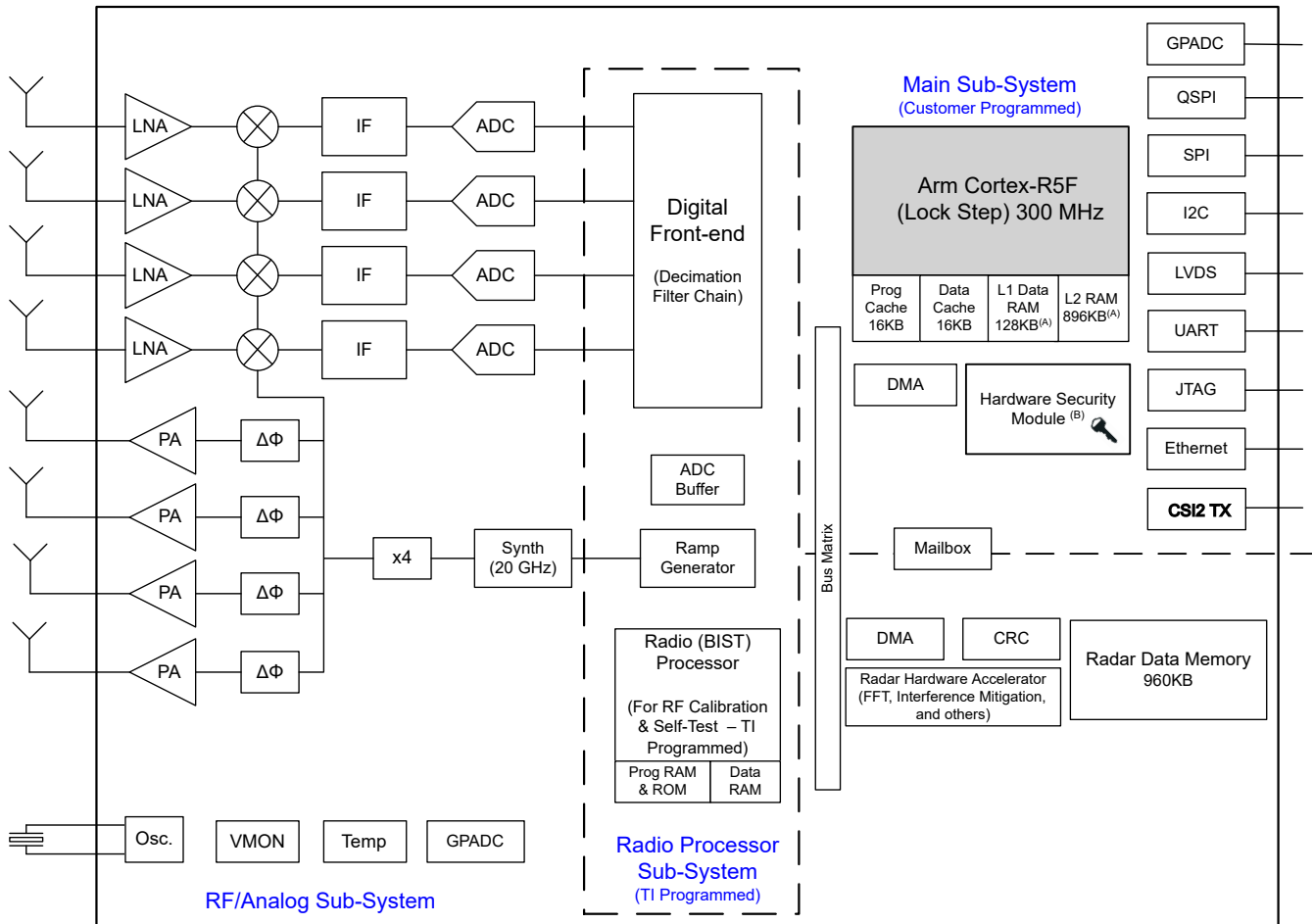

Figure 3-1. Functional Block Diagram

Table of Contents

1 Features	1		
2 Applications	2		
3 Description	2		
3.1 Functional Block Diagram.....	4		
4 Device Comparison	6		
5 Related Products	8		
6 Pin Configurations and Functions	9		
6.1 Pin Diagram.....	9		
6.2 Pin Attributes.....	14		
6.3 Signal Descriptions - Digital.....	27		
6.4 Signal Descriptions - Analog.....	33		
7 Specifications	35		
7.1 Absolute Maximum Ratings.....	35		
7.2 ESD Ratings.....	35		
7.3 Power-On Hours (POH)	36		
7.4 Recommended Operating Conditions.....	36		
7.5 VPP Specifications for One-Time Programmable (OTP) eFuses.....	37		
7.6 Power Supply Specifications.....	38		
7.7 Power Consumption Summary.....	39		
7.8 RF Specifications.....	39		
7.9 Thermal Resistance Characteristics	40		
7.10 Power Supply Sequencing and Reset Timing.....	42		
7.11 Input Clocks and Oscillators.....	43		
7.12 Peripheral Information.....	44		
		7.13 Emulation and Debug.....	64
		8 Detailed Description	66
		8.1 Overview.....	66
		8.2 Functional Block Diagram.....	66
		8.3 Subsystems.....	67
		8.4 Other Subsystems.....	71
		9 Monitoring and Diagnostics	73
		9.1 Monitoring and Diagnostic Mechanisms.....	73
		10 Applications, Implementation, and Layout	76
		10.1 Application Information.....	76
		10.2 Short and Medium Range Radar.....	76
		10.3 Reference Schematic.....	76
		11 Device and Documentation Support	77
		11.1 Device Support.....	77
		11.2 Device Nomenclature.....	77
		11.3 Tools and Software.....	78
		11.4 Documentation support.....	78
		11.5 Support Resources.....	78
		11.6 Trademarks.....	78
		11.7 Electrostatic Discharge Caution.....	78
		11.8 Glossary.....	79
		12 Revision History	79
		13 Mechanical, Packaging, and Orderable Information	81

4 Device Comparison

Table 4-1. Device Features Comparison

FUNCTION	AWR2544	AWR2944	AWR2243	AWR1843
Launch on Package (LOP) Antenna	Yes	—	—	—
Number of receivers	4	4	4	4
Number of transmitters	4	4	3 ⁽¹⁾	3 ⁽¹⁾
On-chip memory	2MB	4MB	—	2MB
Max I/F (Intermediate Frequency) (MHz)	20	15 ⁽²⁾	20	10
Max real/complex 2x sampling rate (Msps)	45 ⁽²⁾	37.5	45	25
Max complex 1x sampling rate (Msps)	— ⁽²⁾	—	22.5	12.5
Safety and Security ⁽³⁾				
Hardware Security Module (HSM) ⁽⁶⁾	Yes	Yes	—	—
Security Accelerators ⁽⁶⁾	Yes	Yes	—	Yes
AEC-Q100 Qualified	Yes	Yes	Yes	Yes
Processor				
DSP (C6xx)	—	Yes	—	Yes
MCU (RxF)	Yes ⁽⁴⁾	Yes ⁽⁵⁾	—	Yes
Hardware accelerator	Yes ⁽⁵⁾	Yes ⁽⁶⁾	—	Yes
Peripherals				
Serial Peripheral Interface (SPI) ports	1	2	1	2
Quad Serial Peripheral Interface (QSPI)	1	Yes	—	Yes
LVDS/Debug	Yes	Yes	Yes	Yes
Aurora LVDS	—	Yes	—	—
Ethernet Interface	Yes	Yes	—	—
Inter-Integrated Circuit (I ² C) interface	1	1	1	1
Controller Area Network (DCAN) interface	—	—	—	Yes
CAN FD	—	2	—	1
Trace	Yes	Yes	—	Yes
EPWM	Yes	Yes	—	Yes
DMM Interface	—	Yes	—	Yes
GPADC	Yes	Yes ⁽⁷⁾	Yes	Yes
CSI2 TX	Yes	—	Yes	—
CSI2 RX	—	Yes	—	—
Cascade (20-GHz sync)	—	—	Yes	—
JTAG	Yes	Yes	—	Yes
Per chirp configurable Tx phase shifter	Yes	Yes	Yes	Yes
Product status ⁽⁷⁾	PRODUCT PREVIEW (PP), ADVANCE INFORMATION (AI), or PRODUCTION DATA (PD)	AI	PD	PD

- (1) 3 Tx Simultaneous operation in AWR1843 and AWR2243 is supported only with 1V LDO bypass and PA LDO disable mode. In this mode 1V supply needs to be fed on the VOUT PA pin. Please refer to the respective datasheets for more information.
- (2) AWR2544 supports a real only receiver.
- (3) Developed for Functional Safety applications, the AWR2544 device is targeted to support hardware integrity up to ASIL-B. For other devices, refer to the respective Datasheets.
- (4) In AWR2544, Main-Subsystem Processing core is changed from ARM CR4F in AWR1843 to ARM CR5F.
- (5) The hardware accelerator in AWR2544 is upgraded to HWA1.5 with additional features as compared to AWR1843.
- (6) Only applicable for AWR2544 Secure Part Variant

- (7) PRODUCTION DATA information is current as of publication date. Products conform to specifications per the terms of the Texas Instruments standard warranty. Production processing does not necessarily include testing of all parameters. ADVANCE INFORMATION concerns new products in the sampling or preproduction phase of development. Characteristic data and other specifications are subject to change without notice.

5 Related Products

For information about other devices in this family of products or related products see the links that follow.

mmWave Sensors TI's mmWave sensors rapidly and accurately sense range, angle and velocity with less power using the smallest footprint mmWave sensor portfolio for automotive applications.

Automotive mmWave Sensors TI's automotive mmWave sensor portfolio offers high-performance radar front end to ultra-high resolution, small and low-power single-chip radar solutions. TI's scalable sensor portfolio enables design and development of ADAS system solution for every performance, application and sensor configuration ranging from comfort functions to safety functions in all vehicles.

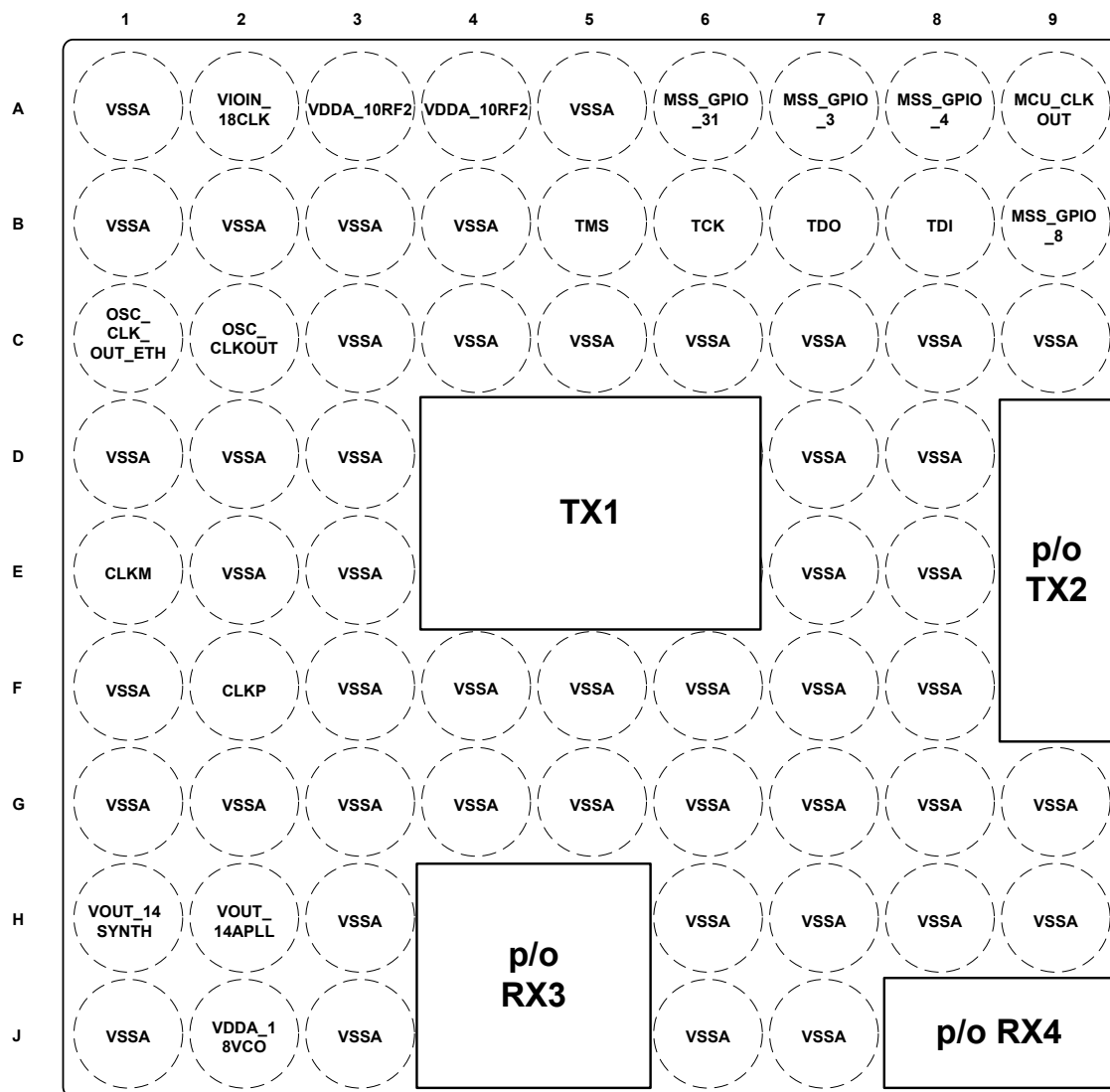

Not to scale

1	2
3	4

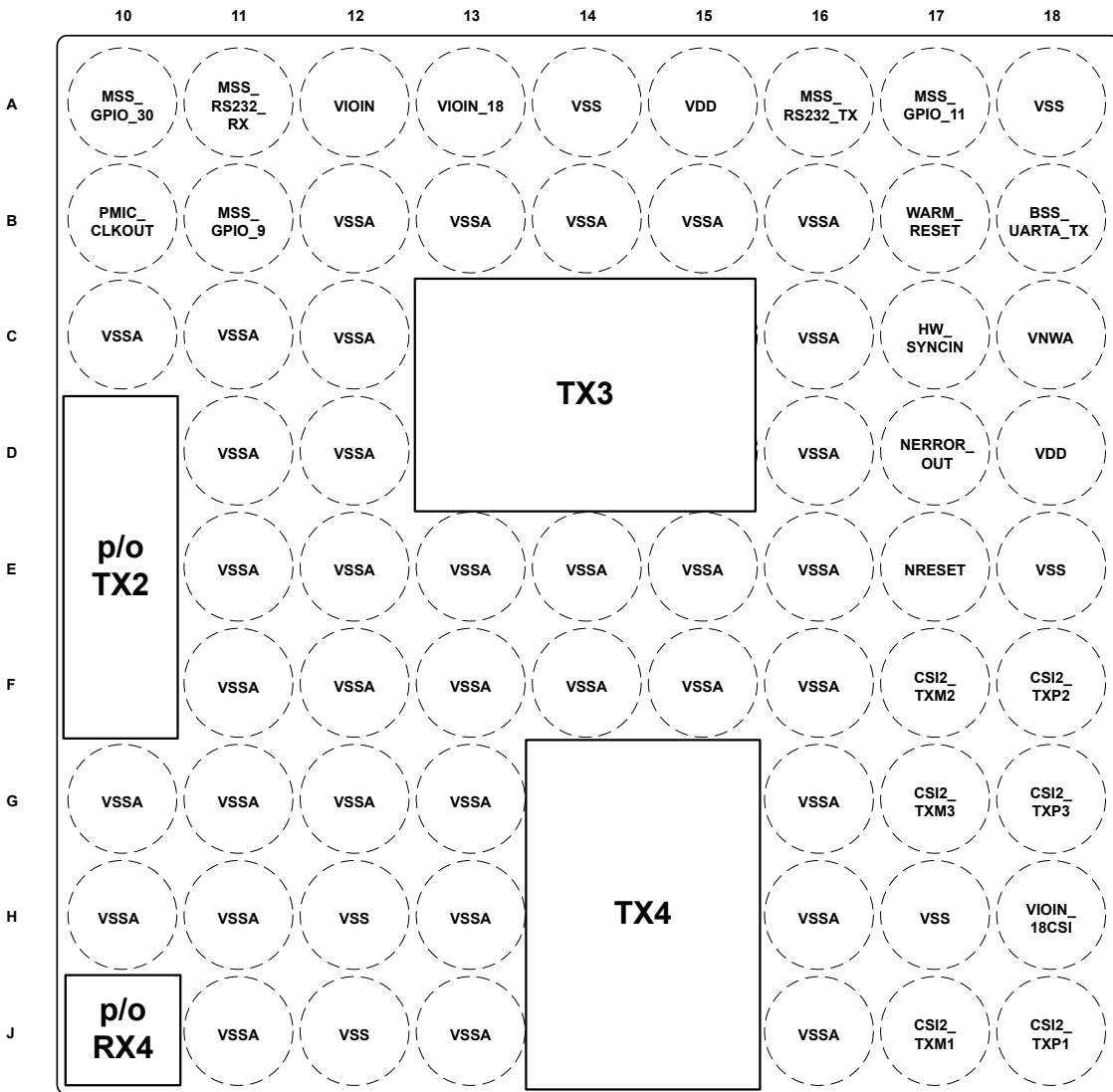

Not to scale

1	2
3	4

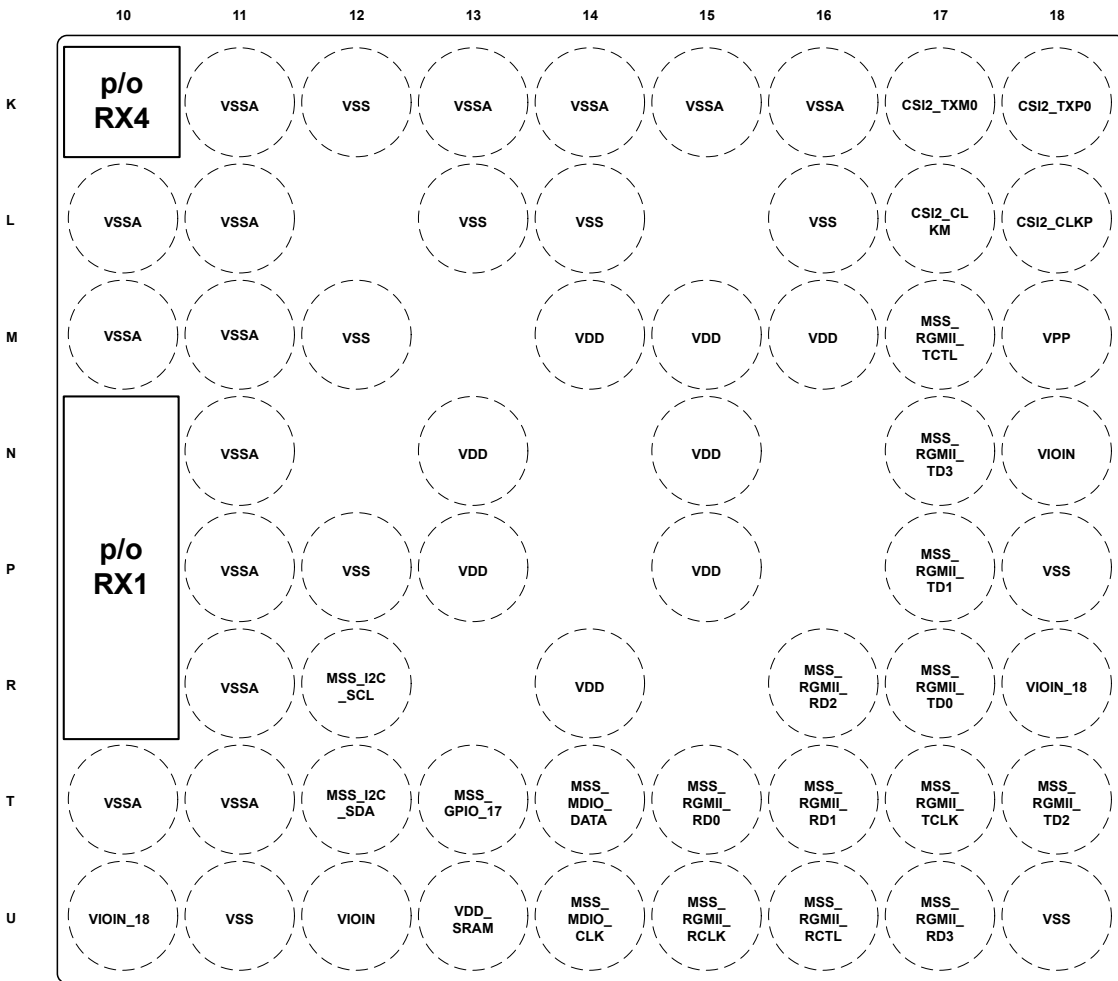

Not to scale

1	2
3	4

Figure 6-1. Pin Diagram

6.2 Pin Attributes

Table 6-1. Pin Attributes (AMQ / FCCSP Package)

BALL NUMBER	BALL NAME (DEFAULT)	MUX SIGNAL NAME	MODE	TYPE	BALL RESET STATE	PULL UP/DOWN TYPE
U3	MSS_MIBSPIB_CS1	MSS_GPIO_12	0	IO	OUTPUT DISABLED	PD
		MSS_MIBSPIA_HOSTIRQ	1	O		
		ADC_VALID	2	O		
		RSVD	3	I		
		RSVD	4	O		
		RSVD	5	O		
U5	MSS_GPIO_0	MSS_MIBSPIB_CS1	6	IO		
		MSS_GPIO_13	0	IO	OUTPUT DISABLED	PD
		MSS_GPIO_0	1	IO		
		PMIC_CLKOUT	2	O		
		MSS_EPWM_TZ2	3	I		
		RSVD	4	O		
		RSVD	5	O		
		RSVD	6	IO		
		RSVD	7	I		
		RSVD	8	O		
		RSVD	9	O		
		MSS_EPWMA1	10	O		
		MSS_EPWMB0	11	O		
		RSVD	12	IO		
		U4	MSS_GPIO_1	MSS_GPIO_16	0	IO
MSS_GPIO_1	1			IO		
SYNC_OUT	2			O		
MSS_EPWM_TZ1	3			I		
RSVD	4			O		
RSVD	5			O		
RSVD	6			IO		
BSS_UARTA_TX	7			O		
READY_INT	8			O		
LVDS_VALID	9			O		
RSVD	10			O		
RSVD	11			O		
RSVD	12			IO		
MSS_MIBSPIB_CS1	13			IO		
RSVD	14			IO		
MSS_EPWMA_SYNCI	15	I				
T3	MSS_MIBSPIB_SDO	MSS_GPIO_21	0	IO	OUTPUT DISABLED	PU

Table 6-1. Pin Attributes (AMQ / FCCSP Package) (continued)

BALL NUMBER	BALL NAME (DEFAULT)	MUX SIGNAL NAME	MODE	TYPE	BALL RESET STATE	PULL UP/DOWN TYPE
		MSS_MIBSPIB_SDO	1	IO		
		MSS_I2CA_SDA	2	IO		
		MSS_EPWMA0	3	O		
		RSVD	4	O		
		RSVD	5	O		
		RSVD	6	I		
		RSVD	7	IO		
U2	MSS_MIBSPIB_SDI	MSS_GPIO_22	0	IO	OUTPUT DISABLED	PU
		MSS_MIBSPIB_SDI	1	IO		
		MSS_I2CA_SCL	2	IO		
		MSS_EPWMB0	3	O		
		RSVD	4	O		
		RSVD	5	O		
		RSVD	6	IO		
		RSVD	7	IO		
R1	MSS_MIBSPIB_CLK	MSS_GPIO_5	0	IO	OUTPUT DISABLED	PU
		MSS_MIBSPIB_CLK	1	IO		
		MSS_UARTA_RX	2	IO		
		MSS_EPWMC0	3	O		
		RSVD	4	O		
		RSVD	5	O		
		MSS_UARTB_TX	6	IO		
		BSS_UARTA_TX	7	O		
		RSVD	8	IO		
T1	MSS_MIBSPIB_CS0	MSS_GPIO_4	0	IO	OUTPUT DISABLED	PU
		MSS_MIBSPIB_CS0	1	IO		
		MSS_UARTA_TX	2	IO		
		RSVD	3	I		
		RSVD	4	O		
		RSVD	5	O		
		MSS_UARTB_TX	6	IO		
		BSS_UARTA_TX	7	O		
		RSVD	8	IO		
		RSVD	9	IO		
U8	MSS_QSPI_0	MSS_GPIO_8	0	IO	OUTPUT DISABLED	PD
		MSS_QSPI_0	1	IO		
		MSS_MIBSPIB_MISO	2	IO		
		RSVD	3	I		
		RSVD	4	O		

Table 6-1. Pin Attributes (AMQ / FCCSP Package) (continued)

BALL NUMBER	BALL NAME (DEFAULT)	MUX SIGNAL NAME	MODE	TYPE	BALL RESET STATE	PULL UP/DOWN TYPE
		RSVD	5	O		
		RSVD	6	O		
		RSVD	7	O		
U7	MSS_QSPI_1	MSS_GPIO_9	0	IO	OUTPUT DISABLED	PD
		MSS_QSPI_1	1	I		
		MSS_MIBSPIB_MOSI	2	IO		
		RSVD	3	I		
		RSVD	4	O		
		RSVD	5	O		
		RSVD	6	O		
		RSVD	7	O		
		MSS_MIBSPIB_CS2	8	IO		
U6	MSS_QSPI_2	MSS_GPIO_10	0	IO	OUTPUT DISABLED	PU
		MSS_QSPI_2	1	I		
		ADC_VALID	2	O		
		RSVD	3	I		
		RSVD	4	O		
		RSVD	5	O		
		RSVD	6	O		
		RSVD	7	O		
		RSVD	8	IO		
T5	MSS_QSPI_3	MSS_GPIO_11	0	IO	OUTPUT DISABLED	PU
		MSS_QSPI_3	1	I		
		ADC_VALID	2	O		
		RSVD	3	I		
		RSVD	4	O		
		RSVD	5	O		
		RSVD	6	O		
		RSVD	7	O		
		RSVD	8	IO		
T7	MSS_QSPI_CLK	MSS_GPIO_7	0	IO	OUTPUT DISABLED	PD
		MSS_QSPI_CLK	1	IO		
		MSS_MIBSPIB_CLK	2	IO		
		RSVD	3	I		
		RSVD	4	O		
		RSVD	5	O		
		RSVD	6	IO		
T6	MSS_QSPI_CS	MSS_GPIO_6	0	IO	OUTPUT DISABLED	PU
		MSS_QSPI_CS	1	O		

Table 6-1. Pin Attributes (AMQ / FCCSP Package) (continued)

BALL NUMBER	BALL NAME (DEFAULT)	MUX SIGNAL NAME	MODE	TYPE	BALL RESET STATE	PULL UP/DOWN TYPE
		MSS_MIBSPIB_CS0	2	IO		
		RSVD	3	I		
		RSVD	4	O		
		RSVD	5	O		
B17	WARM_RESET	WARM_RESET	0	IO	HI-Z (OPEN DRAIN)	
D17	NERROR_OUT	NERROR_OUT	0	IO	HI-Z (OPEN DRAIN)	
B6	TCK	MSS_GPIO_17	0	IO	OUTPUT DISABLED	PD
		TCK	1	I		
		MSS_UARTB_TX	2	IO		
		RSVD	3	I		
		RSVD	4	O		
		RSVD	5	O		
		BSS_UARTA_RX	6	I		
		RSVD	7	I		
		RSVD	8	IO		
B5	TMS	MSS_GPIO_18	0	IO	OUTPUT DISABLED	PU
		TMS	1	IO		
		BSS_UARTA_TX	2	O		
		RSVD	3	I		
		RSVD	4	O		
		RSVD	5	O		
		RSVD	6	IO		
B8	TDI	MSS_GPIO_23	0	IO	OUTPUT DISABLED	PU
		TDI	1	I		
		MSS_UARTA_RX	2	IO		
		RSVD	3	I		
		RSVD	4	O		
		RSVD	5	O		
		RSVD	6	I		
		RSVD	7	IO		
B7	TDO	MSS_GPIO_24	0	IO	OUTPUT DISABLED	HI-Z
		TDO	1	O		
		MSS_UARTA_TX	2	IO		
		RSVD	3	I		
		RSVD	4	O		
		RSVD	5	O		
		MSS_UARTB_TX	6	IO		
		BSS_UARTA_TX	7	O		
		RSVD	8	O		

Table 6-1. Pin Attributes (AMQ / FCCSP Package) (continued)

BALL NUMBER	BALL NAME (DEFAULT)	MUX SIGNAL NAME	MODE	TYPE	BALL RESET STATE	PULL UP/DOWN TYPE
		RSVD	9	IO		
A9	MCU_CLKOUT	MSS_GPIO_25	0	IO	OUTPUT DISABLED	PD
		MCU_CLKOUT	1	O		
		TRACE_CLK	2	O		
		RSVD	3	I		
		RSVD	4	O		
		RSVD	5	O		
		RSVD	6	I		
		FRAME_START	7	O		
		READY_INT	8	O		
		LVDS_VALID	9	O		
		BSS_UARTA_RX	10	I		
		RSVD	11	O		
		MSS_EPWMA0	12	O		
		RSVD	13	O		
		RSVD	14	IO		
		OBS_CLKOUT	15	O		
T4	MSS_GPIO_2	MSS_GPIO_26	0	IO	OUTPUT DISABLED	PD
		MSS_GPIO_2	1	IO		
		RSVD	2	O		
		RSVD	3	IO		
		RSVD	4	O		
		RSVD	5	O		
		RSVD	6	IO		
		MSS_UARTB_TX	7	IO		
		MSS_GPIO_2	8	IO		
		SYNC_OUT	9	O		
		PMIC_CLKOUT	10	O		
		CHIRP_START	11	O		
		CHIRP_END	12	O		
		FRAME_START	13	O		
		MSS_EPWM_TZ0	14	I		
		LVDS_VALID	15	O		
B10	PMIC_CLKOUT	MSS_GPIO_27	0	IO	OUTPUT DISABLED	HI-Z
		PMIC_CLKOUT	1	O		
		OBS_CLKOUT	2	O		
		TRACE_CTL	3	O		
		RSVD	4	O		
		RSVD	5	O		

Table 6-1. Pin Attributes (AMQ / FCCSP Package) (continued)

BALL NUMBER	BALL NAME (DEFAULT)	MUX SIGNAL NAME	MODE	TYPE	BALL RESET STATE	PULL UP/DOWN TYPE
		CHIRP_START	6	O		
		CHIRP_END	7	O		
		FRAME_START	8	O		
		READY_INT	9	O		
		LVDS_VALID	10	O		
		MSS_EPWMA1	11	O		
		MSS_EPWMB0	12	O		
		RSVD	13	IO		
C17	HW_SYNCIN	MSS_GPIO_28	0	IO	OUTPUT DISABLED	PD
		HW_SYNCIN	1	I		
		ADC_VALID	2	O		
		RSVD	3	IO		
		RSVD	4	O		
		RSVD	5	O		
		MSS_UARTB_RX	6	IO		
		RSVD	7	IO		
		RSVD	8	IO		
		SYNC_OUT	9	O		
T2	MSS_MIBSPIB_CS2	MSS_GPIO_29	0	IO	OUTPUT DISABLED	HI-Z
		SYNC_OUT	1	O		
		RCOSC_CLK	2	O		
		RSVD	3	IO		
		RSVD	4	O		
		RSVD	5	O		
		READY_INT	6	O		
		LVDS_VALID	7	O		
		RSVD	8	O		
		RSVD	9	IO		
		MSS_MIBSPIB_CS1	10	IO		
		MSS_MIBSPIB_CS2	11	IO		
		MSS_EPWMB0	12	O		
		MSS_EPWMB1	13	O		
A11	MSS_RS232_RX	MSS_GPIO_15	0	IO	OUTPUT DISABLED	PU
		MSS_RS232_RX	1	IO		
		MSS_UARTA_RX	2	IO		
		RSVD	4	O		
		RSVD	5	O		
		BSS_UARTA_TX	6	O		
		MSS_UARTB_RX	7	IO		

Table 6-1. Pin Attributes (AMQ / FCCSP Package) (continued)

BALL NUMBER	BALL NAME (DEFAULT)	MUX SIGNAL NAME	MODE	TYPE	BALL RESET STATE	PULL UP/DOWN TYPE
		RSVD	8	IO		
		MSS_I2CA_SCL	9	IO		
		MSS_EPWMB0	10	O		
		MSS_EPWMB1	11	O		
		MSS_EPWMC0	12	O		
A16	MSS_RS232_TX	MSS_GPIO_14	0	IO	OUTPUT DISABLED	PU
		MSS_RS232_TX	1	IO		
		RSVD	3	O		
		RSVD	4	O		
		MSS_UARTA_TX	5	IO		
		MSS_UARTB_TX	6	IO		
		BSS_UARTA_TX	7	O		
		READY_INT	8	O		
		LVDS_VALID	9	O		
		RSVD	10	IO		
		MSS_I2CA_SDA	11	IO		
		MSS_EPWMA0	12	O		
		MSS_EPWMA1	13	O		
		RSVD	14	IO		
		MSS_EPWMB0	15	O		
A6	MSS_GPIO_31	TRACE_DATA_0	0	O	OUTPUT DISABLED	PD
		MSS_GPIO_31	1	IO		
		RSVD	2	IO		
		RSVD	3	I		
		MSS_UARTA_TX	4	IO		
		RSVD	5	I		
		MSS_GPIO_31	6	IO		
		RSVD	7	IO		
		RSVD	8	I		
		RSVD	9	I		
		MSS_I2CA_SDA	10	IO		
A10	MSS_GPIO_30	TRACE_DATA_1	0	O	OUTPUT DISABLED	PD
		MSS_GPIO_30	1	IO		
		RSVD	2	IO		
		MSS_EPWMC_SYNCI	3	I		
		MSS_UARTA_RX	4	IO		
		RSVD	5	I		
		MSS_GPIO_0	6	IO		
		RSVD	7	IO		

Table 6-1. Pin Attributes (AMQ / FCCSP Package) (continued)

BALL NUMBER	BALL NAME (DEFAULT)	MUX SIGNAL NAME	MODE	TYPE	BALL RESET STATE	PULL UP/DOWN TYPE
		RSVD	8	I		
		RSVD	9	I		
		MSS_I2CA_SCL	10	IO		
B9	MSS_GPIO_8	TRACE_DATA_2	0	O	OUTPUT DISABLED	PD
		MSS_GPIO_29	1	IO		
		RSVD	2	IO		
		MSS_EPWMB_SYNCI	3	I		
		RSVD	4	I		
		RSVD	5	I		
		MSS_GPIO_1	6	IO		
		MSS_GPIO_8	7	IO		
		MSS_EPWMA0	8	O		
		MSS_CPTS0_TS_GENF0	9	O		
		CHIRP_START	10	O		
		CHIRP_END	11	O		
		FRAME_START	12	O		
		READY_INT	13	O		
		ADC_VALID	14	O		
B11	MSS_GPIO_9	TRACE_DATA_3	0	O	OUTPUT DISABLED	PD
		MSS_GPIO_28	1	IO		
		RSVD	2	IO		
		RSVD	3	I		
		MSS_EPWMC_SYNCO	4	O		
		RSVD	5	I		
		MSS_GPIO_2	6	IO		
		MSS_GPIO_9	7	IO		
		MSS_EPWMA1	8	O		
		MSS_CPTS0_TS_GENF1	9	O		
		CHIRP_START	10	O		
		CHIRP_END	11	O		
		FRAME_START	12	O		
		READY_INT	13	O		
		ADC_VALID	14	O		
A7	MSS_GPIO_3	TRACE_DATA_4	0	O	OUTPUT DISABLED	PD
		MSS_GPIO_3	1	IO		
		RSVD	2	IO		
		RSVD	3	I		
		MSS_EPWMB_SYNCO	4	O		
		RSVD	5	I		

Table 6-1. Pin Attributes (AMQ / FCCSP Package) (continued)

BALL NUMBER	BALL NAME (DEFAULT)	MUX SIGNAL NAME	MODE	TYPE	BALL RESET STATE	PULL UP/DOWN TYPE
		MSS_GPIO_27	6	IO		
		MSS_EPWMB0	7	O		
		MSS_CPTS0_TS_GENF2	8	O		
		XREF_CLK1	9	I		
		MSS_CPTS0_TS_GENF1	10	O		
		MSS_CPTS0_HW1TSPUSH	11	I		
		ADC_VALID	12	O		
A8	MSS_GPIO_4	TRACE_DATA_5	0	O	OUTPUT DISABLED	PD
		MSS_GPIO_4	1	IO		
		RSVD	2	IO		
		RSVD	3	I		
		MSS_EPWM_TZ2	4	I		
		MSS_UARTB_TX	5	IO		
		MSS_GPIO_26	6	IO		
		MSS_EPWMB1	7	O		
		MSS_CPTS0_TS_COMP	8	O		
		XREF_CLK0	9	I		
		MSS_CPTS0_HW2TSPUSH	10	I		
		READY_INT	11	O		
B18	BSS_UARTA_TX	TRACE_DATA_6	0	O	OUTPUT DISABLED	PD
		MSS_GPIO_5	1	IO		
		RSVD	2	IO		
		RSVD	3	I		
		MSS_EPWM_TZ1	4	I		
		BSS_UARTA_TX	5	O		
		MSS_GPIO_25	6	IO		
		MSS_GPIO_10	7	IO		
		MSS_EPWMC0	8	O		
		MSS_CPTS0_TS_GENF2	9	O		
		MSS_CPTS0_HW1TSPUSH	10	I		
		CHIRP_START	11	O		
A17	MSS_GPIO_11	TRACE_DATA_7	0	O	OUTPUT DISABLED	PD
		MSS_GPIO_6	1	IO		
		RSVD	2	IO		
		RSVD	3	I		
		MSS_EPWM_TZ0	4	I		
		RSVD	5	IO		
		MSS_GPIO_24	6	IO		
		MSS_GPIO_11	7	IO		

Table 6-1. Pin Attributes (AMQ / FCCSP Package) (continued)

BALL NUMBER	BALL NAME (DEFAULT)	MUX SIGNAL NAME	MODE	TYPE	BALL RESET STATE	PULL UP/DOWN TYPE
		MSS_EPWMC1	8	O		
		MSS_CPTS0_TS_COMP	9	O		
		MSS_CPTS0_TS_GENF0	10	O		
		MSS_CPTS0_HW2TSPUSH	11	I		
		CHIRP_END	12	O		
T13	MSS_GPIO_17	MSS_GPIO_17	0	IO	OUTPUT DISABLED	PD
		MSS_MII_COL	1	I		
		MSS_RMII_REFCLK	2	IO		
		RSVD	3	I		
		RSVD	4	IO		
		RSVD	5	I		
		MSS_EPWMA1	6	O		
T12	MSS_I2CA_SDA	MSS_GPIO_18	0	IO		HI-Z
		MSS_MII_CRS	1	I		
		MSS_RMII_CRS_DV	2	I		
		MSS_I2CA_SDA	3	IO		
		RSVD	4	IO		
		RSVD	5	I		
		MSS_EPWMB1	6	O		
R12	MSS_I2CA_SCL	MSS_GPIO_19	0	IO		HI-Z
		MSS_MII_RXER	1	I		
		MSS_RMII_RXER	2	I		
		MSS_I2CA_SCL	3	IO		
		RSVD	4	IO		
		RSVD	5	I		
		MSS_EPWMC1	6	O		
M17	MSS_RGMII_TCTL	MSS_GPIO_20	0	IO	OUTPUT DISABLED	PD
		MSS_MII_TXEN	1	O		
		MSS_RMII_TXEN	2	O		
		MSS_RGMII_TCTL	3	O		
		RSVD	4	IO		
		RSVD	5	I		
		MSS_EPWMA0	6	O		
U16	MSS_RGMII_RCTL	MSS_GPIO_21	0	IO		HI-Z
		MSS_MII_RXDV	1	I		
		RSVD	2	I		
		MSS_RGMII_RCTL	3	I		
		MSS_UARTB_RX	5	IO		
		MSS_EPWMB0	6	O		

Table 6-1. Pin Attributes (AMQ / FCCSP Package) (continued)

BALL NUMBER	BALL NAME (DEFAULT)	MUX SIGNAL NAME	MODE	TYPE	BALL RESET STATE	PULL UP/DOWN TYPE
N17	MSS_RGMII_TD3	MSS_GPIO_22	0	IO	OUTPUT DISABLED	PD
		MSS_MII_TXD3	1	O		
		RSVD	2	I		
		MSS_RGMII_TD3	3	O		
		RSVD	4	IO		
		MSS_UARTB_TX	5	IO		
		MSS_EPWMC0	6	O		
T18	MSS_RGMII_TD2	MSS_GPIO_23	0	IO	OUTPUT DISABLED	PD
		MSS_MII_TXD2	1	O		
		RSVD	2	I		
		MSS_RGMII_TD2	3	O		
P17	MSS_RGMII_TD1	MSS_GPIO_24	0	IO	OUTPUT DISABLED	PD
		MSS_MII_TXD1	1	O		
		MSS_RMII_TXD1	2	O		
		MSS_RGMII_TD1	3	O		
R17	MSS_RGMII_TD0	MSS_GPIO_25	0	IO	OUTPUT DISABLED	PD
		MSS_MII_TXD0	1	O		
		MSS_RMII_TXD0	2	O		
		MSS_RGMII_TD0	3	O		
T17	MSS_RGMII_TCLK	MSS_GPIO_26	0	IO	OUTPUT DISABLED	PD
		MSS_MII_TXCLK	1	I		
		RSVD	2	I		
		MSS_RGMII_TCLK	3	O		
U15	MSS_RGMII_RCLK	MSS_GPIO_27	0	IO	OUTPUT DISABLED	PD
		MSS_MII_RXCLK	1	I		
		RSVD	2	I		
		MSS_RGMII_RCLK	3	I		
U17	MSS_RGMII_RD3	MSS_GPIO_28	0	IO		HI-Z
		MSS_MII_RXD3	1	I		
		RSVD	2	I		
		MSS_RGMII_RD3	3	I		
R16	MSS_RGMII_RD2	MSS_GPIO_29	0	IO		HI-Z
		MSS_MII_RXD2	1	I		
		RSVD	2	I		
		MSS_RGMII_RD2	3	I		
T16	MSS_RGMII_RD1	MSS_GPIO_30	0	IO		HI-Z
		MSS_MII_RXD1	1	I		
		MSS_RMII_RXD1	2	I		
		MSS_RGMII_RD1	3	I		

Table 6-1. Pin Attributes (AMQ / FCCSP Package) (continued)

BALL NUMBER	BALL NAME (DEFAULT)	MUX SIGNAL NAME	MODE	TYPE	BALL RESET STATE	PULL UP/DOWN TYPE
T15	MSS_RGMII_RD0	MSS_GPIO_31	0	IO		HI-Z
		MSS_MII_RXD0	1	I		
		MSS_RMII_RXD0	2	I		
		MSS_RGMII_RD0	3	I		
T14	MSS_MDIO_DATA	MSS_GPIO_30	0	IO	OUTPUT DISABLED	PU
		MSS_MDIO_DATA	1	IO		
		RSVD	2	I		
		RSVD	3	I		
U14	MSS_MDIO_CLK	MSS_GPIO_31	0	IO	OUTPUT DISABLED	PU
		MSS_MDIO_CLK	1	O		
		RSVD	2	I		
		RSVD	3	I		
P1	MSS_UARTA_RX	MSS_GPIO_12	0	IO	OUTPUT DISABLED	PU
		MSS_CPTS0_TS_SYNC	1	O		
		RSVD	2	I		
		MSS_GPIO_8	3	IO		
		MSS_UARTB_RX	4	IO		
		MSS_UARTA_RX	5	IO		
R2	MSS_UARTA_TX	RSVD	6	IO		
		MSS_GPIO_13	0	IO		HI-Z
		MSS_CPTS0_HW2TSPUSH	1	I		
		RSVD	2	I		
		MSS_GPIO_9	3	IO		
		MSS_UARTB_TX	4	IO		
P2	MSS_UARTB_TX	MSS_UARTA_TX	5	IO		
		RSVD	6	IO		
		MSS_GPIO_0	0	IO		HI-Z
		RSVD	1	IO		
		RSVD	2	I		
		MSS_EPWMB_SYNCI	3	I		
		RSVD	4	IO		
		MSS_UARTA_TX	5	IO		
		MSS_UARTB_TX	6	IO		
		RSVD	7	I		
		LVDS_VALID	8	O		
		RSVD	9	I		
		RSVD	10	I		
		RSVD	11	I		

Table 6-1. Pin Attributes (AMQ / FCCSP Package) (continued)

BALL NUMBER	BALL NAME (DEFAULT)	MUX SIGNAL NAME	MODE	TYPE	BALL RESET STATE	PULL UP/DOWN TYPE
		MSS_GPIO_31	12	IO		

6.3 Signal Descriptions - Digital

Note

All digital IO pins of the device (except NERROR_OUT and WARM_RESET) are non-failsafe; hence, care needs to be taken that they are not driven externally without the VIO supply being present to the device.

Note

The GPIO state during the power supply ramp is not ensured. In case the GPIO is used in the application where the state of the GPIO is critical, even when NRESET is low, a tri-state buffer should be used to isolate the GPIO output from the radar device and a pull resistor used to define the required state in the application. The NRESET signal to the radar device could be used to control the output enable (OE) of the tri-state buffer.

FUNCTION	SIGNAL NAME	PIN TYPE	DESCRIPTION	BALL NUMBER
SPI Interface	MSS_MIBSPIB_CLK	O	SPI Channel B - Clock	R1, T7
	MSS_MIBSPIB_SDO	O	SPI Channel B - Serial Data Out	T3
	MSS_MIBSPIB_SDI	I	SPI Channel B - Serial Data In	U2
	MSS_MIBSPIB_CS0	O	SPI Channel B - Chip Select 0	T1, T6
	MSS_MIBSPIB_CS1	O	SPI Channel B - Chip Select 1	U3, U4, T2
	MSS_MIBSPIB_CS2	O	PI Channel B - Chip Select 2	T2, U7
UART (MSS)	MSS_UARTA_RX	I	Main Subsystem - UART A Receive (For Flash programming)	P1, A10, A11, B8, R1
	MSS_UARTA_TX	IO	Main Subsystem - UART A Transmit (For Flash programming)	R2, A6, A16, B7, P2, T1
	MSS_UARTB_TX	IO	Main Subsystem - UART B Transmit	P2, A8, A16, B4, B6, N17, R1, R2, T1, T4
	MSS_UARTB_RX	I	Main Subsystem - UART B Receive	A11, C17, P1, U16
QSPI for Serial Flash	MSS_QSPI_0	IO	QSPI Data Line #0 (Used with Serial Data Flash)	U8
	MSS_QSPI_1	I	QSPI Data Line #1 (Used with Serial Data Flash)	U7
	MSS_QSPI_2	I	QSPI Data Line #2 (Used with Serial Data Flash)	U6
	MSS_QSPI_3	I	QSPI Data Line #3 (Used with Serial Data Flash)	T5
	MSS_QSPI_CLK	IO	QSPI clock (Used with Serial Data Flash)	T7
	MSS_QSPI_CS	O	QSPI chip select (Used with Serial Data Flash)	T6
I2C interface	MSS_I2C_SCL	IO	I2C Clock	R12, A10, A11, U2
	MSS_I2C_SDA	IO	I2C Data	T12, A6, A16, T3
RS232 UART	MSS_RS232_RX	IO	Debug UART (Operates as Bus Master) - Receive Signal	A11
	MSS_RS232_TX	IO	Debug UART (Operates as Bus Master) - Transmit Signal	A16

FUNCTION	SIGNAL NAME	PIN TYPE	DESCRIPTION	BALL NUMBER
PWM Module	MSS_EPWMA0	O	PWM Module 1 - Output A0	A9, A16, B9, M17, T3
	MSS_EPWMA1	O	PWM Module 1 - Output A1	A16, B10, B11, U5, T13
	MSS_EPWMA_SYNCI	I	PWM Module 1 - Sync Input	U4
	MSS_EPWMA_SYNCO	O	PWM Module 1 - Sync Output	A7, B11
	MSS_EPWMB0	O	PWM Module 2 - Output B0	A7, A11, A16, B10, T2, U2, U5, U16
	MSS_EPWMB1	O	PWM Module 2 - Output B1	A8, A11, T2, T12
	MSS_EPWMB_SYNCI	I	PWM Module 2 - Sync Input	B9, P2
	MSS_EPWMB_SYNCO	O	PWM Module 2 - Sync Output	A7
	MSS_EPWMC0	O	PWM Module 3 - Output C0	A11, B18, N17, R1
	MSS_EPWMC1	O	PWM Module 3 - Output C1	A17, R12
	MSS_EPWMC_SYNCI	I	PWM Module 3 - Sync Input	A10
	MSS_EPWMC_SYNCO	O	PWM Module 3 - Sync Output	B11
	MSS_EPWM_TZ0	I	PWM module Trip Signal 0	A17, T4
	MSS_EPWM_TZ1	I	PWM module Trip Signal 1	B18, U4
	MSS_EPWM_TZ2	I	PWM module Trip Signal 2	A8, U5

FUNCTION	SIGNAL NAME	PIN TYPE	DESCRIPTION	BALL NUMBER
RGMII/ RMII/MII Ethernet	MSS_MII_COL	I	MSS Ethernet MII Collision Detect	T13
	MSS_MII_CRS	I	MSS Ethernet MII Carrier Sense	T12
	MSS_MII_RXER	I	MSS Ethernet MII Receive Error	R12
	MSS_MII_TXEN	O	MSS Ethernet MII Transmit Enable	M17
	MSS_MII_RXDV	I	MSS Ethernet MII Receive Data Valid	U16
	MSS_MII_TXD3	O	MSS Ethernet MII Transmit Data 3	N17
	MSS_MII_TXD2	O	MSS Ethernet MII Transmit Data 2	T18
	MSS_MII_TXD1	O	MSS Ethernet MII Transmit Data 1	P17
	MSS_MII_TXD0	O	MSS Ethernet MII Transmit Data 0	R17
	MSS_MII_TXCLK	I	MSS Ethernet MII Transmit Clock	T17
	MSS_MII_RXCLK	I	MSS Ethernet MII Receive Clock	U15
	MSS_MII_RXD3	I	MSS Ethernet MII Receive Data 3	U17
	MSS_MII_RXD2	I	MSS Ethernet MII Receive Data 2	R16
	MSS_MII_RXD1	I	MSS Ethernet MII Receive Data 1	T16
	MSS_MII_RXD0	I	MSS Ethernet MII Receive Data 0	T15
	MSS_RMII_REFCLK	IO	MSS Ethernet RMII Clock Input	T13
	MSS_RMII_CRS_DV	I	MSS Ethernet RMII Carrier Sense/Receive Data Valid	T12
	MSS_RMII_RXER	I	MSS Ethernet RMII Receive Error	R12
	MSS_RMII_TXEN	O	MSS Ethernet RMII Transmit Enable	M17
	MSS_RMII_TXD1	O	MSS Ethernet RMII Transmit Data 1	P17
	MSS_RMII_TXD0	O	MSS Ethernet RMII Transmit Data 0	R17
	MSS_RMII_RXD1	I	MSS Ethernet MII Receive Data 1	T16
	MSS_RMII_RXD0	I	MSS Ethernet MII Receive Data 0	T15
	MSS_RGMII_TCTL	O	MSS Ethernet RGMII Transmit Control	M17
	MSS_RGMII_RCTL	I	MSS Ethernet RGMII Receive Control	U16
	MSS_RGMII_TD3	O	MSS Ethernet RGMII Transmit Data 3	N17
	MSS_RGMII_TD2	O	MSS Ethernet RGMII Transmit Data 2	T18
	MSS_RGMII_TD1	O	MSS Ethernet RGMII Transmit Data 1	P17
	MSS_RGMII_TD0	O	MSS Ethernet RGMII Transmit Data 0	R17
	MSS_RGMII_TCLK	O	MSS Ethernet RGMII Transmit Clock	T17
	MSS_RGMII_RCLK	I	MSS Ethernet RGMII Receive Clock	U15
	MSS_RGMII_RD3	I	MSS Ethernet RGMII Receive Data 3	U17
	MSS_RGMII_RD2	I	MSS Ethernet RGMII Receive Data 2	R16
	MSS_RGMII_RD1	I	MSS Ethernet RGMII Receive Data 1	T16
	MSS_RGMII_RD0	I	MSS Ethernet RGMII Receive Data 0	T15
	MSS_MDIO_DATA	IO	MSS Ethernet Manage Data Input/Output data	T14
MSS_MDIO_CLK	O	MSS Ethernet Manage Data Input/Output Clock	U14	
MSS_CPTS0_TS_SYNC	O	Ethernet Timestamp SYNC output	P1	
MSS_CPTS0_HW2TSPUSH	I	Ethernet Hardware Timestamp Input Pin	A8, A17, R2	
MSS_CPTS0_HW1TSPUSH	I	Ethernet Hardware Timestamp Input Pin	A7, B18	

FUNCTION	SIGNAL NAME	PIN TYPE	DESCRIPTION	BALL NUMBER
Trace Signal	TRACE_DATA_0	O	Debug Trace Output - Data Line	A6
	TRACE_DATA_1	O	Debug Trace Output - Data Line	A10
	TRACE_DATA_2	O	Debug Trace Output - Data Line	B9
	TRACE_DATA_3	O	Debug Trace Output - Data Line	B11
	TRACE_DATA_4	O	Debug Trace Output - Data Line	A7
	TRACE_DATA_5	O	Debug Trace Output - Data Line	A8
	TRACE_DATA_6	O	Debug Trace Output - Data Line	B18
	TRACE_DATA_7	O	Debug Trace Output - Data Line	A17
	TRACE_CLK	O	Debug Trace Output - Clock	A9
	TRACE_CTL	O	Debug Trace Output - Control	B10

FUNCTION	SIGNAL NAME	PIN TYPE	DESCRIPTION	BALL NUMBER
General-purpose I/Os	MSS_GPIO_0	IO	General-purpose I/O	U5, A10, P2
	MSS_GPIO_1	IO	General-purpose I/O	U4, B9
	MSS_GPIO_2	IO	General-purpose I/O	T4, B11
	MSS_GPIO_3	IO	General-purpose I/O	A7
	MSS_GPIO_4	IO	General-purpose I/O	A8, T1
	MSS_GPIO_5	IO	General-purpose I/O	B18, R1
	MSS_GPIO_6	IO	General-purpose I/O	A17, T6
	MSS_GPIO_7	IO	General-purpose I/O	T7
	MSS_GPIO_8	IO	General-purpose I/O	B9, P1, U8
	MSS_GPIO_9	IO	General-purpose I/O	B11, R2, U7
	MSS_GPIO_10	IO	General-purpose I/O	B18, U6
	MSS_GPIO_11	IO	General-purpose I/O	A17, T5
	MSS_GPIO_12	IO	General-purpose I/O	P1, U2
	MSS_GPIO_13	IO	General-purpose I/O	R2, U5
	MSS_GPIO_14	IO	General-purpose I/O	A16
	MSS_GPIO_15	IO	General-purpose I/O	A11
	MSS_GPIO_16	IO	General-purpose I/O	U4
	MSS_GPIO_17	IO	General-purpose I/O	T13, B6
	MSS_GPIO_18	IO	General-purpose I/O	B5, T12
	MSS_GPIO_19	IO	General-purpose I/O	R12
	MSS_GPIO_20	IO	General-purpose I/O	M17
	MSS_GPIO_21	IO	General-purpose I/O	U16, T3
	MSS_GPIO_22	IO	General-purpose I/O	N17, U2
	MSS_GPIO_23	IO	General-purpose I/O	B8, T18
	MSS_GPIO_24	IO	General-purpose I/O	A17, B7, P17
	MSS_GPIO_25	IO	General-purpose I/O	A9, B18, R17
	MSS_GPIO_26	IO	General-purpose I/O	A8, T4, T17
	MSS_GPIO_27	IO	General-purpose I/O	A7, B10, U15
	MSS_GPIO_28	IO	General-purpose I/O	B11, C17, U17
	MSS_GPIO_29	IO	General-purpose I/O	B9, R16, T2
	MSS_GPIO_30	IO	General-purpose I/O	A10, T14, T16
	MSS_GPIO_31	IO	General-purpose I/O	A6, P2, T15, U14
Chirp/Frame signals	ADC_VALID	O	When high, indicating valid ADC samples	A7, B9, B11, C17, T5, U3, U6
	CHIRP_START	O	Pulse signal indicating the start of each chirp	B9, B10, B11, B18, T4
	CHIRP_END	O	Pulse signal indicating the end of each chirp	A17, B9, B10, B11, T4
	FRAME_START	O	Pulse signal indicating the start of each frame	A9, B9, B10, B11, T4

FUNCTION	SIGNAL NAME	PIN TYPE	DESCRIPTION	BALL NUMBER
LVDS_VALID	LVDS_VALID	O	When high, indicating valid LVDS data	A9, A16, B10, P2, T2, T4, U4
External clock out	MCU_CLKOUT	O	Programmable clock given out to external MCU or the processor	A9
	PMIC_CLKOUT	O	Output Clock from the device for PMIC	B10, T4, U5
System Synchronization	HW_SYNCIN	I	Low frequency Synchronization signal input	C17
	SYNC_OUT	O	Low Frequency Synchronization Signal output	C17, T2, T4, U4
Clock Output	OBS_CLKOUT	O	Debug Clock Output	A9, B10
	RCOSC_CLK	O	Debug Clock Output	T2
Reference Clock	XREF_CLK0	I	External reference input clock 0	A8
	XREF_CLK1	I	External reference input clock 1	A7
JTAG	TCK	I	JTAG Test Clock	B6
	TMS	IO	JTAG Test Mode Signal	B5
	TDI	I	JTAG Test Data Input	B8
	TDO	O	JTAG Test Data Output	B7
UART (BSS)	BSS_UARTA_TX	O	Debug UART Transmit [Radar Block]	B18, A16, A11, B5, B7, R1, T1, U4
	BSS_UARTA_RX	I	Debug UART Receive [Radar Block]	A9, B6
Reset	WARM_RESET	IO	Open drain fail safe warm reset signal. Can be driven from PMIC for diagnostic or can be used as status signal that the device is going through reset.	B17
Safety	NERROR_OUT	O	Open drain fail safe output signal. Connected to PMIC/Processor/MCU to indicate that some severe criticality fault has happened. Recovery would be through reset.	D17
Sense On power	SOP[0]	I	<p>The SOP pins are driven externally (weak drive) and the mmWave device senses the state of these pins during bootup to decide the bootup mode. After boot the same pins have other functionality.</p> <ul style="list-style-type: none"> [SOP2 SOP1 SOP0] = [0 0 1] -> Functional QSPI load mode [SOP2 SOP1 SOP0] = [1 0 1] -> UART load mode [SOP2 SOP1 SOP0] = [0 1 1] -> debug and development mode [SOP2 SOP1 SOP0] = [1 1 0] -> JTAG load mode for customer key provisioning <p>The following configurations of SOP pins help decide the reference crystal frequency</p> <ul style="list-style-type: none"> [SOP4 SOP3] = [0 0] -> 40 MHz [SOP4 SOP3] = [1 1] -> 50 MHz 	B7
	SOP[1]	I		T2
	SOP[2]	I		B10
	SOP[3]	I		P2
	SOP[4]	I		R2

FUNCTION	SIGNAL NAME	PIN TYPE	DESCRIPTION	BALL NUMBER
CSI2 / LVDS	CSI2_TXM0 / LVDS_TXM0	O	CSI2 / LVDS Transmitter, Differential Data Output, Lane 0	K17
	CSI2_TXP0 / LVDS_TXP0	O		K18
	CSI2_TXM4 / LVDS_CLKM	O	CSI2 / LVDS Differential Clock	L17
	CSI2_TXP4 / LVDS_CLKP	O		L18
	CSI2_CLKM / CSI2_TXM2 / LVDS_FRCLKM	O	CSI2 / LVDS Differential Frame Clock	F17
	CSI2_CLKP / CSI2_TXP2 / LVDS_FRCLKMP	O		F18
	CSI2_TXM1 / LVDS_TXM1	O	CSI2 / LVDS Transmitter, Differential Data Output, Lane 1	J17
	CSI2_TXP1 / LVDS_TXP1	O		J18
	CSI2_TXM3	O	CSI2 Transmitter - Differential Data Output	G17
	CSI2_TXP3	O	CSI2 Transmitter - Differential Data Output	G18

6.4 Signal Descriptions - Analog

INTERFACE	SIGNAL NAME	PIN TYPE	DESCRIPTION	BALL NUMBER
Waveguide Launches	Transmitter	O	Waveguide Launch for TX outputs	
	Receiver	I	Waveguide Launch for RX inputs	
Reset	NRESET	I	Power on reset for chip. Active low. The NRESET needs to be pulled low for a minimum of 20 µsec to ensure proper device reset.	E17
Reference Oscillator	CLKP	I	In XTAL mode: Input for the reference crystal In External clock mode: Single ended input reference clock port	F2
	CLKM	I	In XTAL mode: Feedback drive for the reference crystal In External clock mode: Connect this port to ground	E1
Reference Clock for Ethernet	OSC_CLK_OUT_ETH	O	Can be used to replace 25MHz crystal used with Ethernet PHY IC (OSC_CLK_OUT_25 on EVM). Please note that this is only useable when a 50MHz reference crystal is used with the device	C1
Reference clock	OSC_CLKOUT	O	Reference clock output from clocking subsystem after cleanup PLL (OSC_CLKTOP on EVM)	C2
Bandgap voltage	VBGAP	O	Device's Band Gap Reference Output	K1

INTERFACE	SIGNAL NAME	PIN TYPE	DESCRIPTION	BALL NUMBER
Power supply	VDD	Power	1.2V digital power supply	A15,D18,M14,M15,M16, N13,N15,P13,P15,R14,U9
	VDD_SRAM	Power	1.2V power rail for internal SRAM	U13
	VNWA	Power	1.2V power rail for SRAM array back bias	C18
	VIOIN	Power	I/O Supply (3.3V or 1.8V): All CMOS I/Os would operate on this supply	A12, N18, U12
	VIOIN_18	Power	1.8V supply for CMOS IO	A13, R18, U10
	VDDA_18CLK	Power	1.8V supply for clock module	A2
	VDDA_18PM	Power	1.8V supply for PM module	K2
	VIOIN_18CSI	Power	1.8V supply for CSI port	H18
	VPP	Power	Voltage supply for fuse chain	M18
Power supply	VDDA_10RF1	Power	1V Analog and RF supply,VDDA_10RF1 and VDDA_10RF2 could be shorted on the board	M1
	VDDA_10RF2	Power	1V Analog and RF supply	A3,A4
	VDDA_18BB	Power	1.8V Analog base band power supply	N1
	VDDA_18VCO	Power	1.8V RF VCO supply	J2
	VSS ⁽²⁾	Ground	Digital ground	A14,A18,E18,H12,H17,J12,L14,L16, M12,P12,P18,U1, U11,U18
Power supply	VSSA ⁽³⁾	Ground	Analog ground	A1,A5,B1,B2,B3,B4,B12, B13,B14,B15,B16,C3,C4,C5,C6,C7, C8,C9,C10,C11,C12, C16,D1,D2,D3,D7,D8,D11, D12,D16,E2,E3,E7,E8,E11, E12,E13,E14,E15,E16,F1, F3,F4,F5,F6,F7,F8,F11,F12,F13,F1 4,F15,F16,G1,G2,G3,G4,G5,G6,G8, G9,G10,G11, G12,G13,G16,H3,H6,H7,H8,H9,H10 ,H11,H13,H16,J1, J3,J6,J7,J11,J13,J16,K3,K6, K7,K11,K13,K14,K15,K16, L3,L4,L5,L6,L7,L8,L9,L10, L11,M3,M4,M5,M6,M7, M8,M9,M10,M11,N3,N7, N8,N11,P3,P7,P8,P11,R3, R4,R5,R6,R7,R8,R11, T8,T9,T10,T11
	VSSA ⁽³⁾	Ground	Analog ground	G12,G13,G16,H3,H6,H7,H8,H9,H10 ,H11,H13,H16,J1, J3,J6,J7,J11,J13,J16,K3,K6, K7,K11,K13,K14,K15,K16, L3,L4,L5,L6,L7,L8,L9,L10, L11,M3,M4,M5,M6,M7, M8,M9,M10,M11,N3,N7, N8,N11,P3,P7,P8,P11,R3, R4,R5,R6,R7,R8,R11, T8,T9,T10,T11
Internal LDO output/ inputs	VOUT_14APLL	O	Internal LDO output	H2
	VOUT_14SYNTH	O	Internal LDO output	H1
General purpose ADC inputs for external voltage monitoring ⁽¹⁾	ADC1	I	ADC Channel 1	L2
	ADC2	I	ADC Channel 2	L1
	ADC5	I	ADC Channel 5	N2
	ADC6	I	ADC Channel 6	M2

(1) For details, see [Section 8.4.3](#)

(2) Corner BGAs are VSS and redundant, meaning if they fail, the device will still function.

(3) The VSSA BGAs around the launches are not redundant and are required for functionality.

7 Specifications

7.1 Absolute Maximum Ratings

over operating free-air temperature range (unless otherwise noted)^{(1) (2)}

PARAMETERS		MIN	MAX	UNIT
VDD	1.2V digital power supply	-0.5	1.4	V
VDD_SRAM	1.2V power rail for internal SRAM	-0.5	1.4	V
VNWA	1.2V power rail for SRAM array back bias	-0.5	1.4	V
VIOIN	I/O supply (3.3V or 1.8V): All CMOS I/Os would operate on this supply.	-0.5	3.8	V
VIOIN_18	1.8V supply for CMOS IO	-0.5	2	V
VDDA_18CLK	1.8V supply for clock module	-0.5	2	V
VDDA_18PM	1.8V supply for the PM Module	-0.5	2	V
VIOIN_18CSI	1.8V supply for CSI2 port	-0.5	2	V
VIOIN_18LVDS	1.8V supply for LVDS port	-0.5	2	V
VDDA_10RF1	1V Analog and RF supply, VDDA_10RF1 and VDDA_10RF2 could be shorted on the board.	-0.5	1.4	V
VDDA_10RF2				
VDDA_18BB	1.8V Analog baseband power supply	-0.5	2	V
VDDA_18VCO supply	1.8V RF VCO supply	-0.5	2	V
RX1-4	Externally applied power on RF inputs		10	dBm
TX1-4	Externally applied power on RF outputs ⁽³⁾		10	dBm
Input and output voltage range	Dual-voltage LVCMOS inputs, 3.3V or 1.8V (Steady State)	-0.3V	VIOIN + 0.3	V
	Dual-voltage LVCMOS inputs, operated at 1.8V/3.3V (Transient Overshoot/Undershoot) or external oscillator input	VIOIN + 20% up to 20% of signal period		
CLKP, CLKM	Input ports for reference crystal	-0.5	2	V
Clamp current	Input or Output Voltages 0.3V above or below their respective power rails. Limit clamp current that flows through the internal diode protection cells of the I/O.	-20	20	mA
T _J	Operating junction temperature range	-40	140	°C
T _{STG}	Storage temperature range after soldered onto PC board	-55	150	°C

- (1) Stresses beyond those listed under *Absolute Maximum Ratings* may cause permanent damage to the device. These are stress ratings only, and functional operation of the device at these or any other conditions beyond those indicated under *Recommended Operating Conditions* is not implied. Exposure to absolute-maximum-rated conditions for extended periods may affect device reliability.
- (2) All voltage values are with respect to V_{SS}, unless otherwise noted.
- (3) This value is for an externally applied signal level on the TX. Additionally, a reflection coefficient up to Gamma = 1 can be applied on the TX output.

7.2 ESD Ratings

			VALUE	UNIT
V _(ESD)	Electrostatic discharge	Human-body model (HBM), per AEC Q100-002 ⁽¹⁾	All pins	±2000
		Charged-device model (CDM), per AEC Q100-011	All pins	±500
			Corner pins	±750

- (1) AEC Q100-002 indicates that HBM stressing shall be in accordance with the ANSI/ESDA/JEDEC JS-001 specification.

7.3 Power-On Hours (POH)

JUNCTION TEMPERATURE (T _J) (1) (2)	OPERATING CONDITION	NOMINAL CVDD VOLTAGE (V)	POWER-ON HOURS [POH] (HOURS)
-40°C	50% duty cycle	1.2	1440 (6%)
75°C			4800 (20%)
95°C			15600 (65%)
130°C			1920 (8%)
140°C			240 (1%)

- (1) This information is provided solely for your convenience and does not extend or modify the warranty provided under TI's standard terms and conditions for TI semiconductor products.
- (2) The specified POH are applicable with max Tx output power settings using the default firmware gain tables. The specified POH would not be applicable, if the Tx gain table is overwritten using an API.

7.4 Recommended Operating Conditions

over operating free-air temperature range (unless otherwise noted)

PARAMETER	DESCRIPTION	MIN	NOM	MAX	UNIT
VDD	1.2V digital power supply	1.14	1.2	1.26	V
VDD_SRAM	1.2V power rail for internal SRAM	1.14	1.2	1.26	V
VNWA	1.2V power rail for SRAM array back bias	1.14	1.2	1.26	V
VIOIN	I/O supply (3.3V or 1.8V): All CMOS I/Os would operate on this supply.	3.135	3.3	3.465	V
		1.71	1.8	1.89	
VIOIN_18	1.8V supply for CMOS IO	1.71	1.8	1.89	V
VDDA_18CLK	1.8V supply for clock module	1.71	1.8	1.89	V
VDDA_18PM	1.8V supply for the PM module	1.71	1.8	1.89	V
VIOIN_18CSI	1.8V supply for CSI2 port	1.71	1.8	1.89	V
VIOIN_18LVDS	1.8V supply for LVDS port	1.71	1.8	1.89	V
VDDA_10RF1	1V Analog and RF supply. VDDA_10RF1 and VDDA_10RF2 could be shorted on the board	0.95	1	1.05	V
VDDA_10RF2					
VDDA_18BB	1.8V Analog baseband power supply	1.71	1.8	1.89	V
VDDA_18VCO	1.8V RF VCO supply	1.71	1.8	1.89	V
V _{IH}	Voltage Input High (1.8V mode)	1.17		0.3 + VIOIN	V
	Voltage Input High (3.3V mode)	2.25		0.3 + VIOIN	
V _{IL}	Voltage Input Low (1.8V mode)	-0.3		0.3*VIOIN	V
	Voltage Input Low (3.3V mode)	-0.3		0.62	
V _{OH}	High-level output threshold (I _{OH} = 6mA)	VIOIN – 450			mV
V _{OL}	Low-level output threshold (I _{OL} = 6mA)			450	mV
NRESET SOP[4:0]	V _{IL} (1.8V Mode)			0.45	V
	V _{IH} (1.8V Mode)	0.96			
	V _{IL} (3.3V Mode)			0.65	
	V _{IH} (3.3V Mode)	1.57			
T _J	Operating junction temperature range	-40		140	°C

7.5 VPP Specifications for One-Time Programmable (OTP) eFuses

This section specifies the operating conditions required for programming the OTP eFuses and is applicable only for high-security (AWR2544 HS) devices. During the process of writing the customer specific keys or other custom information in the eFuse, the user needs to provide the VPP supply.

7.5.1 Recommended Operating Conditions for OTP eFuse Programming

PARAMETER	DESCRIPTION	MIN	NOM	MAX	UNIT
VPP	Supply voltage range for the eFuse ROM domain during normal operation		NC		
	Supply voltage range for the eFuse ROM domain during OTP programming ⁽¹⁾	1.65	1.7	1.75	V
Duration of VPP Supply	If VPP voltage is supplied for more than recommended Hours, it can cause reliability issue			24	hours
	I(VPP)			50	mA

(1) During normal operation, no voltage should be applied to VPP. This can be typically achieved by disabling the external regulator attached to the VPP terminal.

7.5.2 Hardware Requirements

The following hardware requirements must be met when programming keys in the OTP eFuses:

- The VPP power supply must be disabled when not programming OTP registers.

7.5.3 Impact to Your Hardware Warranty

You recognize and accept at your own risk that your use of eFuse permanently alters the TI device. You acknowledge that eFuse can fail due to incorrect operating conditions or programming sequence. Such a failure may render the TI device inoperable and TI will be unable to confirm the TI device conformed to TI device specifications prior to the attempted eFuse. CONSEQUENTLY, in these cases of faulty EFUSE programmability, TI WILL HAVE NO LIABILITY.

7.6 Power Supply Specifications

Table 7-1 describes the four required power rails which must be provided to the AWR2544 from an external power supply. In the case when 1.8V LVCMOS IO is utilized, VIOIN is powered from a 1.8V rail and the 3.3V rail can be omitted, so only three rails must be provided. Also, depending on the power topology utilized, additional power supply filtering can be required for the RF 1.0V and baseband, clock and VCO 1.8V supplies to meet the required ripple specifications. This additional filtering results in separate supply power nets being generated from these four basic rails.

Table 7-1. Power Supply Rails Characteristics

SUPPLY VOLTAGE	DEVICE BLOCKS POWERED FROM THE SUPPLY	DEVICE POWER NETS
1.8 V	Synthesizer and APLL VCOs, crystal oscillator, IF Amplifier stages, ADC, CSI2, LVDS, LVCMOS IO	Input: VDDA_18VCO, VDDA_18CLK, VDDA_18PM, VDDA_18BB, VIOIN_18CSI, VIOIN_18LVDS, VIOIN_18 LDO Output: VOUT_14SYNTH, VOUT_14APLL
1.0 V	Power Amplifier, Low Noise Amplifier, Mixers and LO Distribution	Input: VDDA_10RF2, VDDA_10RF1
3.3 V (or 1.8 V for 1.8 V I/O mode)	LVCMOS IO	VIOIN
1.2 V	Core Digital and SRAM	VDD, VDD_SRAM, VNWA
1.7 V	Programming OTP eFuse (For secure devices)	VPP

The 1.0 V and 1.8 V power supply ripple specifications are mentioned in **Table 7-2**. The spur and ripple levels have a dB to dB relationship, for example, a 1dB increase in supply ripple leads to an approximately 1dB increase in spur level. Values quoted are rms levels for a sinusoidal input applied at the specified frequency.

Table 7-2. Ripple Specifications

FREQUENCY (kHz)	Spur Level (dBc)	RF RAIL	VCO/IF RAIL
		1 V (μV_{RMS})	1.8 V (mV_{RMS})
10	-85	22	10.99
100	-95	8	1.42
200	-98	6	0.73
500	-102	4	0.45
1000	-105	3	0.30
2000	-105	3	0.08
5000	-105	3	0.06
10000	-105	3	0.06
15000	-105	2	0.04
20000	-105	2	0.04

Power Supply Guidelines

The LP8772-Q1 Power Management IC (PMIC) is recommended for an integrated AWR2544 power solution. This cost and space optimized solution is designed to power the AWR2544 radar sensor and its principal peripherals.

List of benefits when using LP8772-Q1 PMIC to power AWR2544:

- Full device performance entitlement as validated on TI Evaluation boards
- Noise/Ripple performance that meets AWR noise/ripple performance specification
 - LP8772-Q1 has high switching frequency switching outside IF band & avoiding the LDOs helps with thermal performance at the system level and bypasses the need for 2nd stage LC filters to suppress the ripple and filter out the spurs.

b. Thermal dissipation does not affect RF performance

7.7 Power Consumption Summary

Table 7-3 and Table 7-4 summarize the power consumption at the power terminals.

Table 7-3. Maximum Current Ratings at Power Terminals

PARAMETER ⁽¹⁾	SUPPLY NAME	DESCRIPTION	MIN	TYP	MAX	UNIT
Current consumption	VDD, VDD_SRAM, VNWA	Total current drawn by all nodes driven by 1.2V rail			2000	mA
	VDDA_10RF1, VDDA_10RF2	Total current drawn by all nodes driven by 1V rail when all 4 transmitters are used			2300	
	VIOIN_18, VDDA_18CLK, VDDA_18PM, VIOIN_18CSI, VIOIN_18LVDS, VDDA_18BB, VDDA_18VCO	Total current drawn by all nodes driven by 1.8V rail			600	
	VIOIN	Total current drawn by all nodes driven by 3.3V rail			50	

(1) The specified current values are at Max supply voltage level (Recommended Operating Conditions).

Table 7-4. Average Power Consumption at Power Terminals

PARAMETER	CONDITION		DESCRIPTION	MIN	TYP ⁽¹⁾	MAX	UNIT
Average power consumption in single chip mode.	3TX, 4RX	25% duty cycle	Use Case: 76-77GHz chirps;		1350		mW
		50% duty cycle	Regular mode, 45 Msps sampling rate, 25.6 ms frame periodicity, 256 chirps/frame, 2-µs idle time, 50-µs ramp end time, 7µs ADC start time and excess ramp time		2000		
	4TX, 4RX	25% duty cycle	Activity of cores :		1400		
		50% duty cycle	<ul style="list-style-type: none"> • 70% MSS R5F • 50% Arm M4F All the above cores under-clocked/ clock-gated during idle times); Ethernet is enabled for data transfer		2100		

(1) The Power consumption numbers are for a typical usecase i.e. for a Nominal device at 25C ambient temperature and nominal voltage conditions.

7.8 RF Specifications

over recommended operating conditions and with run time calibrations enabled (unless otherwise noted)

PARAMETER		MIN	TYP	MAX	UNIT
Receiver	Noise figure		12.5		dB
	1dB compression point (Out Of Band) ⁽¹⁾		-8		dBm
	Maximum gain		44		dB
	Gain range		20		dB
	Gain step size		2		dB
	IF bandwidth ⁽²⁾			20	MHz
	ADC sampling rate			45	Msps
	ADC resolution		12		Bits
	Return loss (S11)		-10		dB
	Gain mismatch variation (over temperature)		±0.5		dB
	Phase mismatch variation (over temperature)		±3		°
	Idle Channel Spurs		-90		dBFS

over recommended operating conditions and with run time calibrations enabled (unless otherwise noted)

PARAMETER		MIN	TYP	MAX	UNIT
Transmitter	Output power		+12.5		dBm
	Phase shifter accuracy		±5		°
	Temperature sensor accuracy		±5		°C
	Amplitude noise		-145		dBc/Hz
Clock subsystem	Frequency range	76		81	GHz
	Ramp rate			250 ⁽³⁾	MHz/μs
	Phase noise at 1-MHz offset	76 to 77GHz (VCO1) 76 to 81GHz (VCO2) ⁽⁴⁾		-96 -95	dBc/Hz

- (1) 1-dB Compression Point (Out Of Band) is measured by feeding a continuous wave tone at 5% of the programmed HPF cut-off frequency (i.e. blocker tone). The compression point is determined by the blocker power that results in a 1dB compression of the blocker tone at the RX ADC.
- (2) The analog IF stages include a second order high pass filter that can be configured to the following -6dB corner frequencies:

Available HPF Corner Frequencies (kHz)
HPF
300, 350, 700, 1400,

The filtering performed by the digital baseband chain is targeted to provide:

- Less than ±0.5dB pass-band ripple/droop, and
 - Better than 60dB anti-aliasing attenuation for any frequency that can alias back into the pass-band.
- (3) The max ramp rate depends on the PLL bandwidth configuration set using the "AWR_APLL_SYNTB_BW_CONTROL_SB" API. For more details, refer to the mmWave Radar Interface Control document.
 - (4) VCO2 supports a maximum continuous range of 4.5GHz. The supported range can span 76-80.5GHz or 76.5-81GHz through VCO2_RANGE_CONFIG in AWR_CAL_MON_FREQUENCY_* API.

Figure 7-1 shows variations of noise figure and in-band P1dB parameters with respect to receiver gain programmed

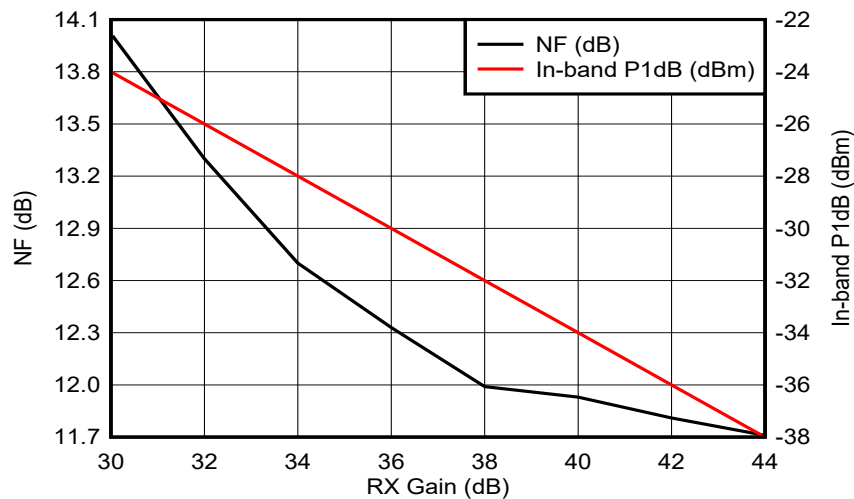

Figure 7-1. Noise Figure, In-band P1dB vs Receiver Gain

7.9 Thermal Resistance Characteristics

THERMAL METRICS ^{(1) (4)}		°C/W ^{(2) (3)}
R _{ΘJC}	Junction-to-case	3.36
R _{ΘJB}	Junction-to-board	5.0
R _{ΘJA}	Junction-to-free air	17.3
Ψ _{JT}	Junction-to-top	0.12

7.9 Thermal Resistance Characteristics (continued)

THERMAL METRICS ^{(1) (4)}		°C/W ^{(2) (3)}
Ψ_{JB}	Junction-to-board	4.9

- (1) For more information about traditional and new thermal metrics, see [Semiconductor and IC Package Thermal Metrics](#).
- (2) °C/W = degrees Celsius per watt.
- (3) These values are based on a JEDEC-defined 2S2P system (with the exception of the Theta JC [$R\theta_{JC}$] value, which is based on a JEDEC-defined 1S0P system) and will change based on environment as well as application. For more information, see these EIA/JEDEC standards:
- JESD51-2, *Integrated Circuits Thermal Test Method Environmental Conditions - Natural Convection (Still Air)*
 - JESD51-3, *Low Effective Thermal Conductivity Test Board for Leaded Surface Mount Packages*
 - JESD51-7, *High Effective Thermal Conductivity Test Board for Leaded Surface Mount Packages*
 - JESD51-9, *Test Boards for Area Array Surface Mount Package Thermal Measurements*
- A junction temperature of 140°C is assumed.
- (4) Air flow = 0m/s

7.10 Power Supply Sequencing and Reset Timing

The AWR2544 device expects all external 1.2V, 1.8V and 3.3V voltage rails as well as all SOP[4:0] lines to be stable before NRESET is deasserted for a successful device bootup. IO state is not guaranteed until the VIOIN and VIOIN_18 supplies are available. Figure 7-2 describes the device wake-up sequence.

Note

Hardware platform must support supplying 1.7V on the VPP pin only during OTP eFuse programming.

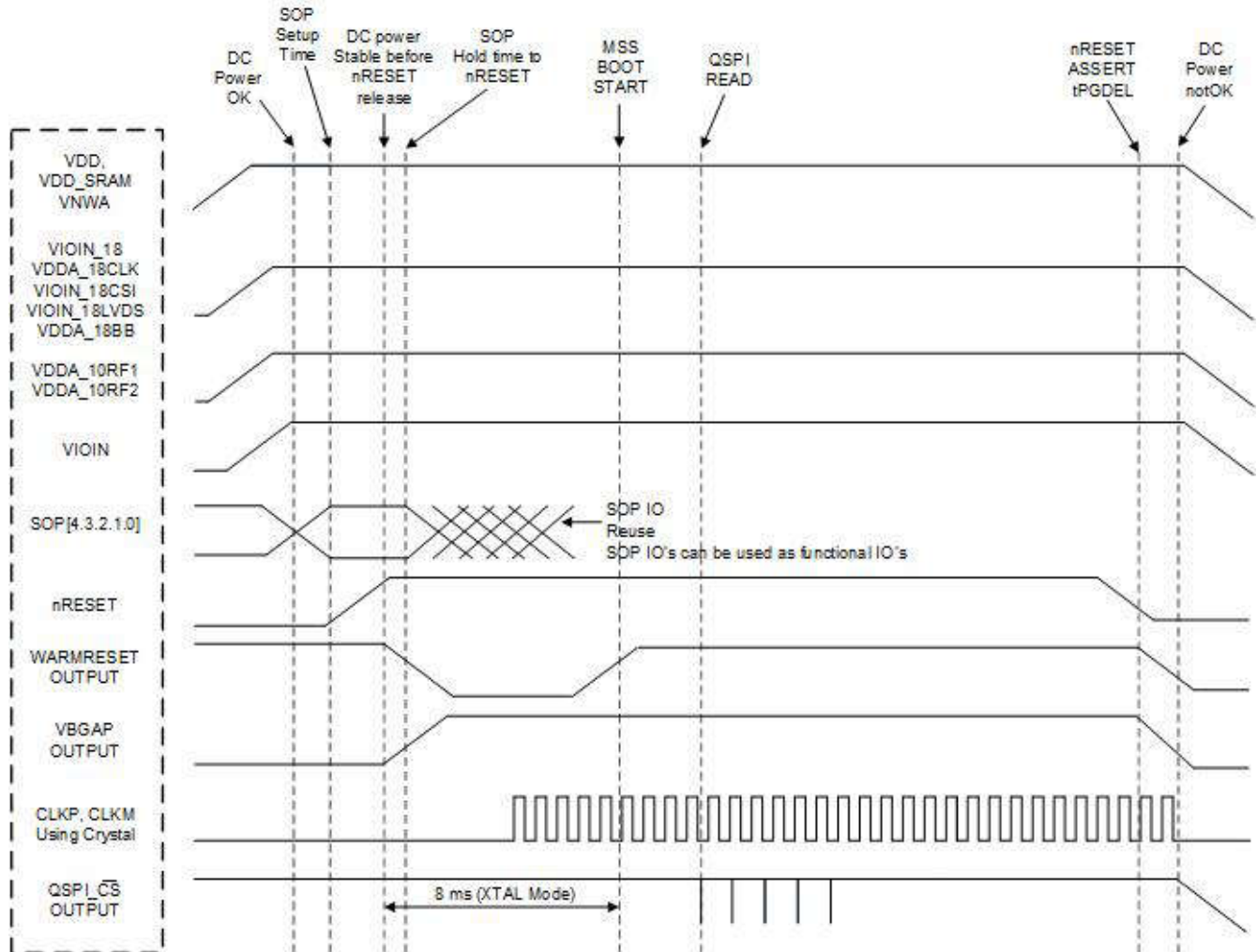

Figure 7-2. Device Wake-up Sequence

7.11 Input Clocks and Oscillators

7.11.1 Clock Specifications

An external crystal is connected to the device pins. [Figure 7-3](#) shows the crystal implementation.

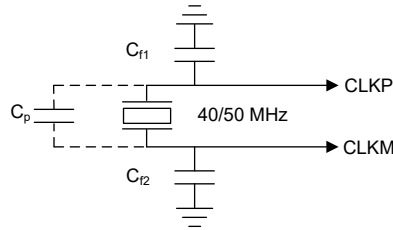

Figure 7-3. Crystal Implementation

Note

The load capacitors, C_{f1} and C_{f2} in [Figure 7-3](#), can be chosen such that [Equation 1](#) is satisfied. C_L in the equation is the load specified by the crystal manufacturer. All discrete components used to implement the oscillator circuit can be placed as close as possible to the associated oscillator CLKP and CLKM pins. Note that C_{f1} and C_{f2} include the parasitic capacitances due to PCB routing.

Note

The board routing parasitics between CLKP/CLKM pins also need to be included in the estimates of C_P

$$C_L = C_{f1} \times \frac{C_{f2}}{C_{f1} + C_{f2}} + C_P \quad (1)$$

[Table 7-5](#) lists the electrical characteristics of the clock crystal.

Table 7-5. Crystal Electrical Characteristics (Oscillator Mode)

NAME	DESCRIPTION	MIN	TYP	MAX	UNIT
f_p	Parallel resonance crystal frequency		50		MHz
C_L	Crystal load capacitance	5	8	12	pF
ESR	Crystal ESR			50	Ω
Temperature range	Expected temperature range of operation	-40		140	$^{\circ}\text{C}$
Frequency tolerance	Crystal frequency tolerance ^{(1) (2)}	-100		100 ⁽³⁾	ppm
Drive level			50	200	μW

- (1) The crystal manufacturer's specification must satisfy this requirement.
- (2) Includes initial tolerance of the crystal, drift over temperature, aging and frequency pulling due to incorrect load capacitance.
- (3) For Ethernet operation, tighter specifications of less than 100PPM frequency error is required. If the Ethernet interface is not used, a PPM error up to 200PPM can be tolerated.

In the case where an external clock is used as the clock resource, the signal is fed to the CLKP pin only; CLKM is grounded. The phase noise requirement is very important when a 50MHz clock is fed externally. [Table 7-6](#) lists the electrical characteristics of the external clock signal.

Table 7-6. External Clock Mode Specifications

PARAMETER		SPECIFICATION			UNIT
		MIN	TYP	MAX	
Input Clock: External AC-coupled sine wave or DC-coupled square wave Phase Noise referred to 50 MHz	Frequency		50		MHz
	AC-Amplitude	700		1200	mV (pp)
	DC-trise/fall			10	ns
	Phase Noise at 1 kHz			-132	dBc/Hz
	Phase Noise at 10kHz			-143	dBc/Hz
	Phase Noise at 100kHz			-152	dBc/Hz
	Phase Noise at 1MHz			-153	dBc/Hz
	Duty Cycle	35		65	%
	Freq Tolerance	-100		100	ppm

7.12 Peripheral Information

Initial peripheral descriptions and features are provided in the following sections. Additional peripheral details and interface timing information shall be provided in a later product preview or datasheet release.

7.12.1 QSPI Flash Memory Peripheral

The device includes a Quad-Serial Peripheral Interface for external flash memory access. Flash memory can be utilized for many purposes including: Secondary boot-loader memory, application program memory, security keys storage, and long-term data logs for security and error conditions.

Following features are supported by the QSPI Interface on the device:

- Loopback skew cancellation for clock signal to supported faster flash interface clock rates
- Two chip-select signals to connect two external flash devices
- Memory mapped 'direct' mode and software triggered 'indirect' mode of operation for performing flash data transfers

7.12.1.1 QSPI Timing Conditions

PARAMETER		MIN	TYP	MAX	UNIT
Input Conditions					
t_R	Input rise time	1		3	ns
t_F	Input fall time	1		3	ns
Output Conditions					
C_{LOAD}	Output load capacitance	5		15	pF

7.12.1.2 QSPI Timing Requirements ^{(1) (2)}

PARAMETER		MIN	TYP	MAX	UNIT
$t_{su(D-SCLK)}$	Setup time, D[3:0] valid before falling SCLK edge (Q12)	5			ns
$t_h(SCLK-D)$	Hold time, D[3:0] valid after falling SCLK edge (Q13)	1			ns

- (1) Clock Mode 0 (clock polarity = 0 ; clock phase = 0) is the mode of operation.
- (2) The Device captures data on the falling clock edge in Clock Mode 0, as opposed to the traditional rising clock edge. Although nonstandard, The falling-edge-based setup and hold time timings have been designed to be compatible with standard SPI devices that launch data on the falling edge in Clock Mode 0.

7.12.1.3 QSPI Switching Characteristics ^{(1) (2)}

PARAMETER		MIN	TYP	MAX	UNIT
$t_c(SCLK)$	Cycle time, sclk	12.5			ns
$t_w(SCLKL)$	Pulse duration, sclk low	$0.5 \cdot P - 0.625$			ns
$t_w(SCLKH)$	Pulse duration, sclk high	$0.5 \cdot P - 0.625$			ns

PARAMETER		MIN	TYP	MAX	UNIT
$t_{d(CS-SCLK)}$	Delay time, sclk falling edge to cs active edge	$-M \cdot P - 1$		$-M \cdot P + 2.5$	ns
$t_{d(SCLK-CS)}$	Delay time, sclk falling edge to cs inactive edge	$N \cdot P - 1$		$N \cdot P + 2.5$	ns
$t_{d(SCLK-D1)}$	Delay time, sclk falling edge to d[0] transition	-2		4	ns
$t_{d(SCLK-D1)}$	Delay time, sclk first falling edge to first d[1] transition (for PHA = 0 only)	$-2 - P$		$4 - P$	ns

- (1) P = SCLK period in ns.
- (2) M = QSPI_SPI_DC_REG.DDx + 1, N = 2

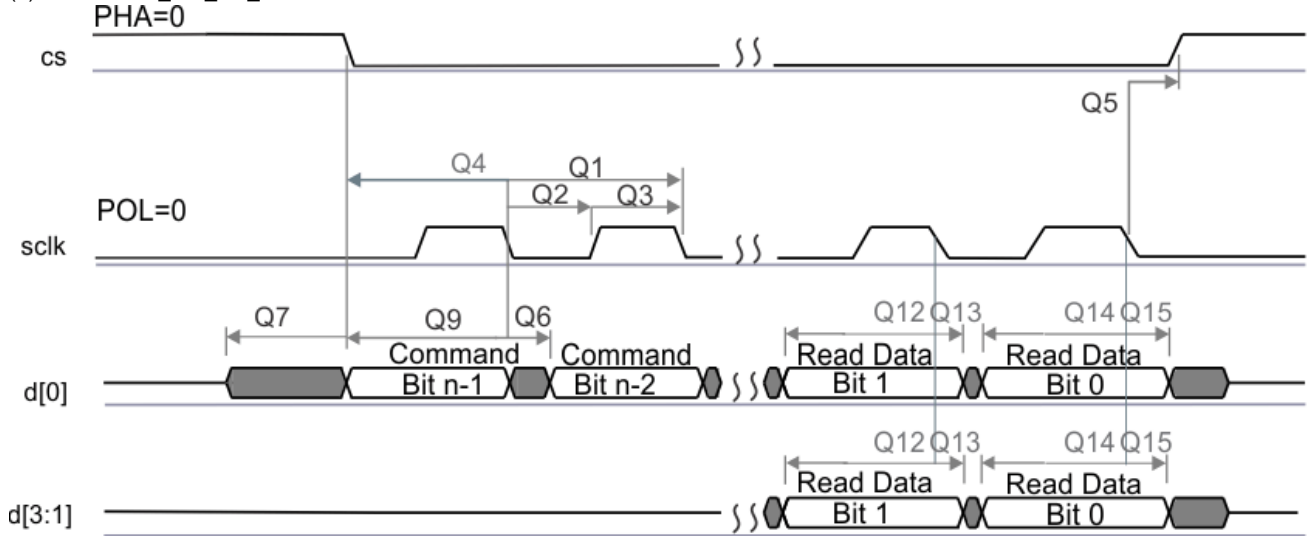

SPRS85v TIMING_OSP11_02

Figure 7-4. QSPI Read (Clock Mode 0)

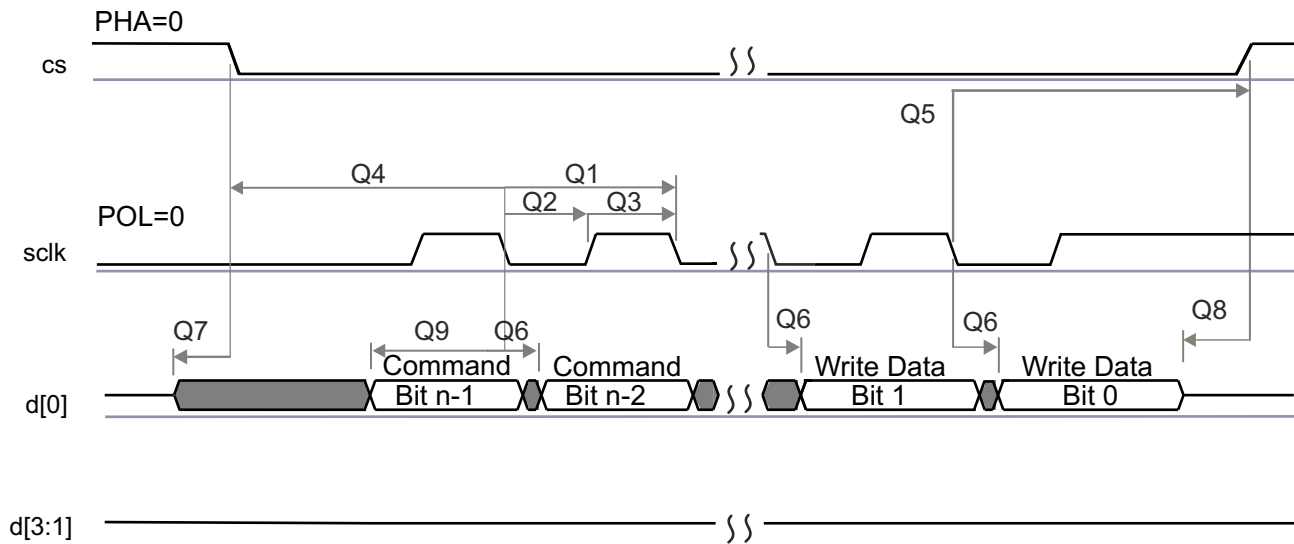

SPRS85v_TIMING_OSP11_04

Figure 7-5. QSPI Write (Clock Mode 0)

7.1.2.2 Multibuffered / Standard Serial Peripheral Interface (MibSPI)

7.1.2.2.1 MibSPI Peripheral Description

The MibSPI/SPI is a high-speed synchronous serial input/output port that allows a serial bit stream of programmed length (2 to 16 bits) to be shifted into and out of the device at a programmed bit-transfer rate. The device includes one Multi-Buffered Serial Peripheral Interface (MibSPI) in the Main Sub-System (MSS). This is intended for external MCU, PMIC, EEPROM and Watchdog communication.

Standard and MibSPI modules have the following features:

- 16-bit shift register
- Receive buffer register
- 8-bit baud clock generator
- SPICLK can be internally-generated (Controller mode) or received from an external clock source (Peripheral mode)
- Maximum clock rate supported over each MIBSPI module shall be 40MHz.
- Each word transferred can have a unique format.
- SPI I/Os not used in the communication can be used as digital input/output signals

7.1.2.2.2 MibSPI Transmit and Receive RAM Organization

The Multibuffer RAM is comprised of 256 buffers. Each entry in the Multibuffer RAM consists of 4 parts: a 16-bit transmit field, a 16-bit receive field, a 16-bit control field and a 16-bit status field. The Multibuffer RAM can be partitioned into multiple transfer group with variable number of buffers each.

[Section 7.1.2.2.2](#) and [Section 7.1.2.2.3](#) assume the operating conditions stated in [Section 7.1.2.2.1](#).

7.1.2.2.2.1 SPI Timing Conditions

		MIN	TYP	MAX	UNIT
Input Conditions					
t_R	Input rise time	1		3	ns
t_F	Input fall time	1		3	ns
Output Conditions					
C_{LOAD}	Output load capacitance	2		20	pF

7.1.2.2.2.2 SPI Controller Mode Switching Parameters (CLOCK PHASE = 0, SPICLK = output, SPISIMO = output, and SPISOMI = input) ^{(1) (2) (3)}

PARAMETER	DESCRIPTION	MIN	TYP	MAX	UNIT
$t_{c(SPC)M}$	Cycle time, SPICLK ⁽⁴⁾	20		$256t_{c(VCLK)}$	ns
$t_{w(SPCH)M}$	Pulse duration, SPICLK high (clock polarity = 0)	$0.5t_{c(SPC)M} - 2$		$0.5t_{c(SPC)M} + 2$	ns
$t_{w(SPCL)M}$	Pulse duration, SPICLK low (clock polarity = 1)	$0.5t_{c(SPC)M} - 2$		$0.5t_{c(SPC)M} + 2$	
$t_{w(SPCL)M}$	Pulse duration, SPICLK low (clock polarity = 0)	$0.5t_{c(SPC)M} - 2$		$0.5t_{c(SPC)M} + 2$	ns
$t_{w(SPCH)M}$	Pulse duration, SPICLK high (clock polarity = 1)	$0.5t_{c(SPC)M} - 2$		$0.5t_{c(SPC)M} + 2$	
$t_{d(SPCH-SIMO)M}$	Delay time, SPISIMO valid before SPICLK low, (clock polarity = 0)	$0.5t_{c(SPC)M} - 7$			ns
$t_{d(SPCL-SIMO)M}$	Delay time, SPISIMO valid before SPICLK high, (clock polarity = 1)	$0.5t_{c(SPC)M} - 7$			
$t_{v(SPCL-SIMO)M}$	Valid time, SPISIMO data valid after SPICLK low, (clock polarity = 0)	$0.5t_{c(SPC)M} - 8$			ns
$t_{v(SPCH-SIMO)M}$	Valid time, SPISIMO data valid after SPICLK high, (clock polarity = 1)	$0.5t_{c(SPC)M} - 8$			

PARAMETER	DESCRIPTION	MIN	TYP	MAX	UNIT
t _{C2TDELAY}	Setup time CS active until SPICLK high (clock polarity = 0)	CSHOLD = 0	(C2TDELAY+2)*t _{c(VCLK)} - 7.5		(C2TDELAY+2) * t _{c(VCLK)} + 7
		CSHOLD = 1	(C2TDELAY + 3) * t _{c(VCLK)} - 7.5		(C2TDELAY+3) * t _{c(VCLK)} + 7
	Setup time CS active until SPICLK low (clock polarity = 1)	CSHOLD = 0	(C2TDELAY+2)*t _{c(VCLK)} - 7.5		(C2TDELAY+2) * t _{c(VCLK)} + 7
		CSHOLD = 1	(C2TDELAY + 3) * t _{c(VCLK)} - 7.5		(C2TDELAY+3) * t _{c(VCLK)} + 7
t _{T2CDELAY}	Hold time, SPICLK low until CS inactive (clock polarity = 0)	0.5*t _{c(SPC)_M} + (T2CDELAY + 1) * t _{c(VCLK)} - 7		0.5*t _{c(SPC)_M} + (T2CDELAY + 1) * t _{c(VCLK)} + 7.5	ns
	Hold time, SPICLK high until CS inactive (clock polarity = 1)	0.5*t _{c(SPC)_M} + (T2CDELAY + 1) * t _{c(VCLK)} - 7		0.5*t _{c(SPC)_M} + (T2CDELAY + 1) * t _{c(VCLK)} + 7.5	ns
t _{su(SOMI-SPCL)_M}	Setup time, SPISOMI before SPICLK low (clock polarity = 0)	5			ns
t _{su(SOMI-SPCH)_M}	Setup time, SPISOMI before SPICLK high (clock polarity = 1)	5			ns
t _{h(SPCL-SOMI)_M}	Hold time, SPISOMI data valid after SPICLK low (clock polarity = 0)	2			ns
t _{h(SPCH-SOMI)_M}	Hold time, SPISOMI data valid after SPICLK high (clock polarity = 1)	2			ns

- (1) The Controller bit (SPIGCRx.0) is set and the CLOCK PHASE bit (SPIFMTx.16) is cleared (where x= 0 or 1).
- (2) t_{c(MSS_VCLK)} = main subsystem clock time = 1 / f_(MSS_VCLK). For more details, refer to the device Technical Reference Manual.
- (3) When the SPI is in controller mode, the following must be true: For PS values from 1 to 255: t_{c(SPC)_M} ≥ (PS + 1)t_{c(MSS_VCLK)} ≥ 25ns, where PS is the prescale value set in the SPIFMTx.[15:8] register bits. For PS values of 0: t_{c(SPC)_M} = 2t_{c(MSS_VCLK)} ≥ 25ns.
- (4) The active edge of the SPICLK signal referenced is controlled by the CLOCK POLARITY bit (SPIFMTx.17).

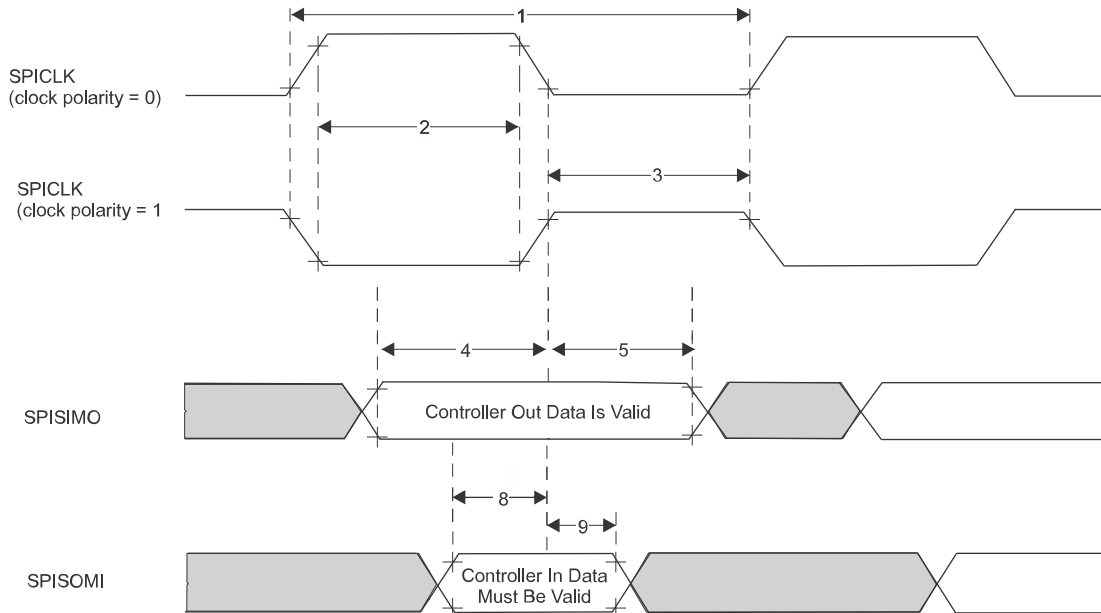

Figure 7-6. SPI Controller Mode External Timing (CLOCK PHASE = 0)

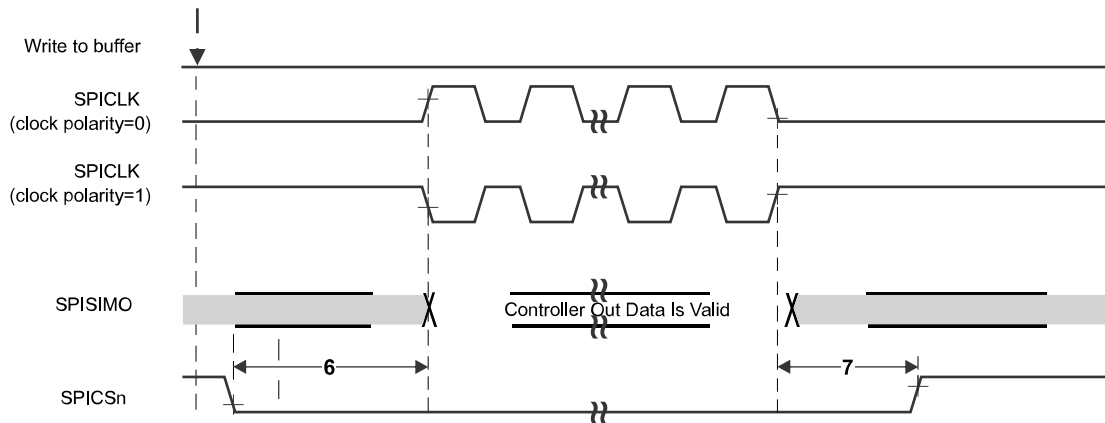

Figure 7-7. SPI Controller Mode Chip Select Timing (CLOCK PHASE = 0)

7.12.2.2.3 SPI Controller Mode Switching Parameters (CLOCK PHASE = 1, SPICLK = output, SPISIMO = output, and SPISOMI = input) (1) (2) (3)

PARAMETER	DESCRIPTION	MIN	TYP	MAX	UNIT
$t_{c(SPC)M}$	Cycle time, SPICLK ⁽⁴⁾	20		$256t_{c(VCLK)}$	ns
$t_{w(SPCH)M}$	Pulse duration, SPICLK high (clock polarity = 0)	$0.5t_{c(SPC)M} - 2$		$0.5t_{c(SPC)M} + 2$	ns
$t_{w(SPCL)M}$	Pulse duration, SPICLK low (clock polarity = 1)	$0.5t_{c(SPC)M} - 2$		$0.5t_{c(SPC)M} + 2$	
$t_{w(SPCL)M}$	Pulse duration, SPICLK low (clock polarity = 0)	$0.5t_{c(SPC)M} - 2$		$0.5t_{c(SPC)M} + 2$	ns
$t_{w(SPCH)M}$	Pulse duration, SPICLK high (clock polarity = 1)	$0.5t_{c(SPC)M} - 2$		$0.5t_{c(SPC)M} + 2$	
$t_{d(SPCH-SIMO)M}$	Delay time, SPISIMO valid before SPICLK low, (clock polarity = 0)	$0.5t_{c(SPC)M} - 7$			ns
$t_{d(SPCL-SIMO)M}$	Delay time, SPISIMO valid before SPICLK high, (clock polarity = 1)	$0.5t_{c(SPC)M} - 7$			
$t_{v(SPCL-SIMO)M}$	Valid time, SPISIMO data valid after SPICLK low, (clock polarity = 0)	$0.5t_{c(SPC)M} - 8$			ns
$t_{v(SPCH-SIMO)M}$	Valid time, SPISIMO data valid after SPICLK high, (clock polarity = 1)	$0.5t_{c(SPC)M} - 8$			
$t_{C2TDELAY}$	Setup time CS active until SPICLK high (clock polarity = 0)	CSHOLD = 0	$0.5t_{c(SPC)M} + (C2TDELAY + 2)t_{c(VCLK)} - 7$	$0.5t_{c(SPC)M} + (C2TDELAY + 2)t_{c(VCLK)} + 7.5$	ns
		CSHOLD = 1	$0.5t_{c(SPC)M} + (C2TDELAY + 2)t_{c(VCLK)} - 7$	$0.5t_{c(SPC)M} + (C2TDELAY + 2)t_{c(VCLK)} + 7.5$	
	Setup time CS active until SPICLK low (clock polarity = 1)	CSHOLD = 0	$0.5t_{c(SPC)M} + (C2TDELAY + 2)t_{c(VCLK)} - 7$	$0.5t_{c(SPC)M} + (C2TDELAY + 2)t_{c(VCLK)} + 7.5$	
		CSHOLD = 1	$0.5t_{c(SPC)M} + (C2TDELAY + 3)t_{c(VCLK)} - 7$	$0.5t_{c(SPC)M} + (C2TDELAY + 3)t_{c(VCLK)} + 7.5$	
$t_{T2CDELAY}$	Hold time, SPICLK low until CS inactive (clock polarity = 0)	$(T2CDELAY + 1)t_{c(VCLK)} - 7.5$		$(T2CDELAY + 1)t_{c(VCLK)} + 7$	ns
	Hold time, SPICLK high until CS inactive (clock polarity = 1)	$(T2CDELAY + 1)t_{c(VCLK)} - 7.5$		$(T2CDELAY + 1)t_{c(VCLK)} + 7$	
$t_{su(SOMI-SPCL)M}$	Setup time, SPISOMI before SPICLK low (clock polarity = 0)	5			ns
$t_{su(SOMI-SPCH)M}$	Setup time, SPISOMI before SPICLK high (clock polarity = 1)	5			
$t_h(SPCL-SOMI)M$	Hold time, SPISOMI data valid after SPICLK low (clock polarity = 0)	2			ns
$t_h(SPCH-SOMI)M$	Hold time, SPISOMI data valid after SPICLK high (clock polarity = 1)	2			

- (1) The Controller bit (SPIGRx.0) is set and the CLOCK PHASE bit (SPIFMTx.16) is set (where x = 0 or 1).
- (2) $t_{c(MSS_VCLK)}$ = main subsystem clock time = $1 / f_{(MSS_VCLK)}$. For more details, refer to the device Technical Reference Manual.
- (3) When the SPI is in Controller mode, the following must be true: For PS values from 1 to 255: $t_{c(SPC)M} \geq (PS + 1)t_{c(MSS_VCLK)} \geq 25$ ns, where PS is the prescale value set in the SPIFMTx.[15:8] register bits. For PS values of 0: $t_{c(SPC)M} = 2t_{c(MSS_VCLK)} \geq 25$ ns.
- (4) The active edge of the SPICLK signal referenced is controlled by the CLOCK POLARITY bit (SPIFMTx.17).

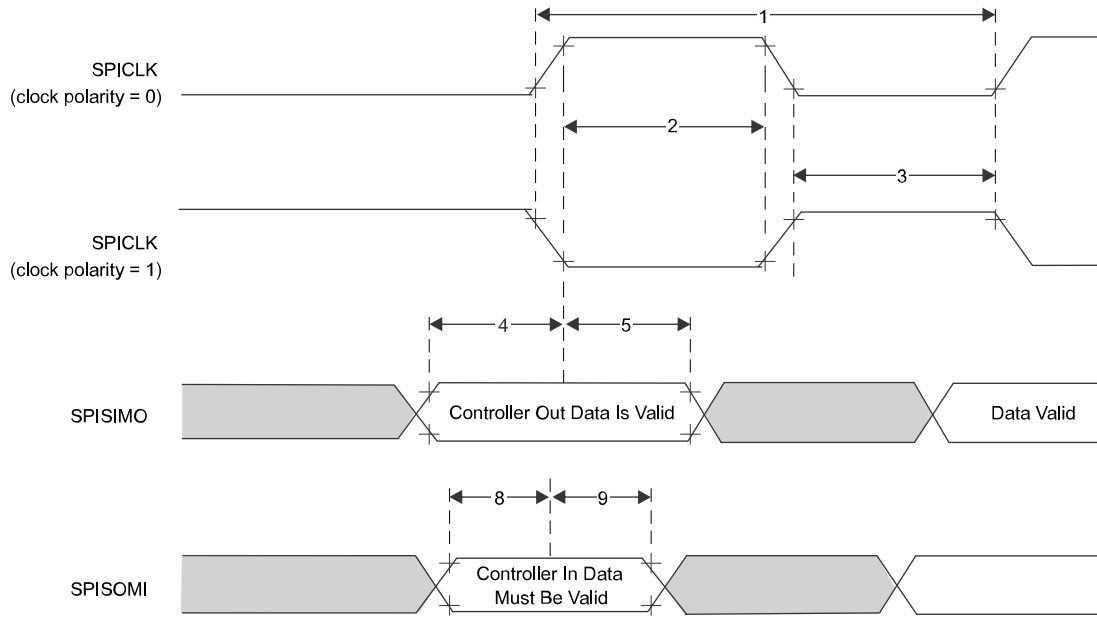

Figure 7-8. SPI Controller Mode External Timing (CLOCK PHASE = 1)

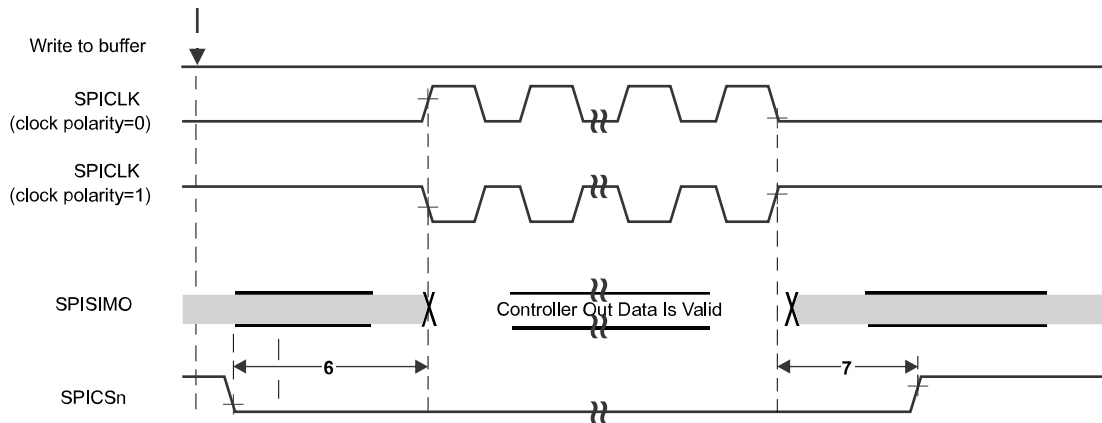

Figure 7-9. SPI Controller Mode Chip Select Timing (CLOCK PHASE = 1)

7.12.2.3 SPI Peripheral Mode I/O Timings

7.12.2.3.1 SPI Peripheral Mode Switching Parameters (SPICLK = input, SPISIMO = input, and SPISOMI = output) ⁽¹⁾ ⁽²⁾ ⁽³⁾

PARAMETER ⁽⁵⁾	DESCRIPTION	MIN	TYP	MAX	UNIT
$t_{c(SPC)S}$	Cycle time, SPICLK ⁽⁴⁾	20			ns
$t_{w(SPCH)S}$	Pulse duration, SPICLK high (clock polarity = 0)	8			ns
$t_{w(SPCL)S}$	Pulse duration, SPICLK low (clock polarity = 1)	8			
$t_{w(SPCL)S}$	Pulse duration, SPICLK low (clock polarity = 0)	8			ns
$t_{w(SPCH)S}$	Pulse duration, SPICLK high (clock polarity = 1)	8			
$t_{d(SPCH-SOMI)S}$	Delay time, SPISOMI valid after SPICLK high (clock polarity = 0)			10	ns
$t_{d(SPCL-SOMI)S}$	Delay time, SPISOMI valid after SPICLK low (clock polarity = 1)			10	
$t_{h(SPCH-SOMI)S}$	Hold time, SPISOMI data valid after SPICLK high (clock polarity = 0)	2			ns
$t_{h(SPCL-SOMI)S}$	Hold time, SPISOMI data valid after SPICLK low (clock polarity = 1)	2			
$t_{d(SPCH-SOMI)S}$	Delay time, SPISOMI valid after SPICLK high (clock polarity = 0; clock phase = 0) OR (clock polarity = 1; clock phase = 1)			14	ns
$t_{d(SPCL-SOMI)S}$	Delay time, SPISOMI valid after SPICLK low (clock polarity = 1; clock phase = 0) OR (clock polarity = 0; clock phase = 1)			14	
$t_{h(SPCH-SOMI)S}$	Hold time, SPISOMI data valid after SPICLK high (clock polarity = 0; clock phase = 0) OR (clock polarity = 1; clock phase = 1)	2			ns
$t_{h(SPCL-SOMI)S}$	Hold time, SPISOMI data valid after SPICLK low (clock polarity = 1; clock phase = 0) OR (clock polarity = 0; clock phase = 1)	2			
$t_{su(SIMO-SPCL)S}$	Setup time, SPISIMO before SPICLK low (clock polarity = 0; clock phase = 0) OR (clock polarity = 1; clock phase = 1)	2.1			ns
$t_{su(SIMO-SPCH)S}$	Setup time, SPISIMO before SPICLK high (clock polarity = 1; clock phase = 0) OR (clock polarity = 0; clock phase = 1)	2.1			
$t_{h(SPCL-SIMO)S}$	Hold time, SPISIMO data valid after SPICLK low (clock polarity = 0; clock phase = 0) OR (clock polarity = 1; clock phase = 1)	1			ns
$t_{h(SPCL-SIMO)S}$	Hold time, SPISIMO data valid after SPICLK high (clock polarity = 1; clock phase = 0) OR (clock polarity = 0; clock phase = 1)	1			

- (1) The Controller bit (SPIGCRx.0) is cleared (where x = 0 or 1).
- (2) The CLOCK PHASE bit (SPIFMTx.16) is either cleared or set for CLOCK PHASE = 0 or CLOCK PHASE = 1 respectively.
- (3) $t_{c(MSS_VCLK)}$ = main subsystem clock time = $1 / f_{(MSS_VCLK)}$. For more details, refer to the device Technical Reference Manual.
- (4) When the SPI is in Peripheral mode, the following must be true: For PS values from 1 to 255: $t_{c(SPC)S} \geq (PS + 1)t_{c(MSS_VCLK)} \geq 25$ ns, where PS is the prescale value set in the SPIFMTx.[15:8] register bits. For PS values of 0: $t_{c(SPC)S} = 2t_{c(MSS_VCLK)} \geq 25$ ns.
- (5) The active edge of the SPICLK signal referenced is controlled by the CLOCK POLARITY bit (SPIFMTx.17).

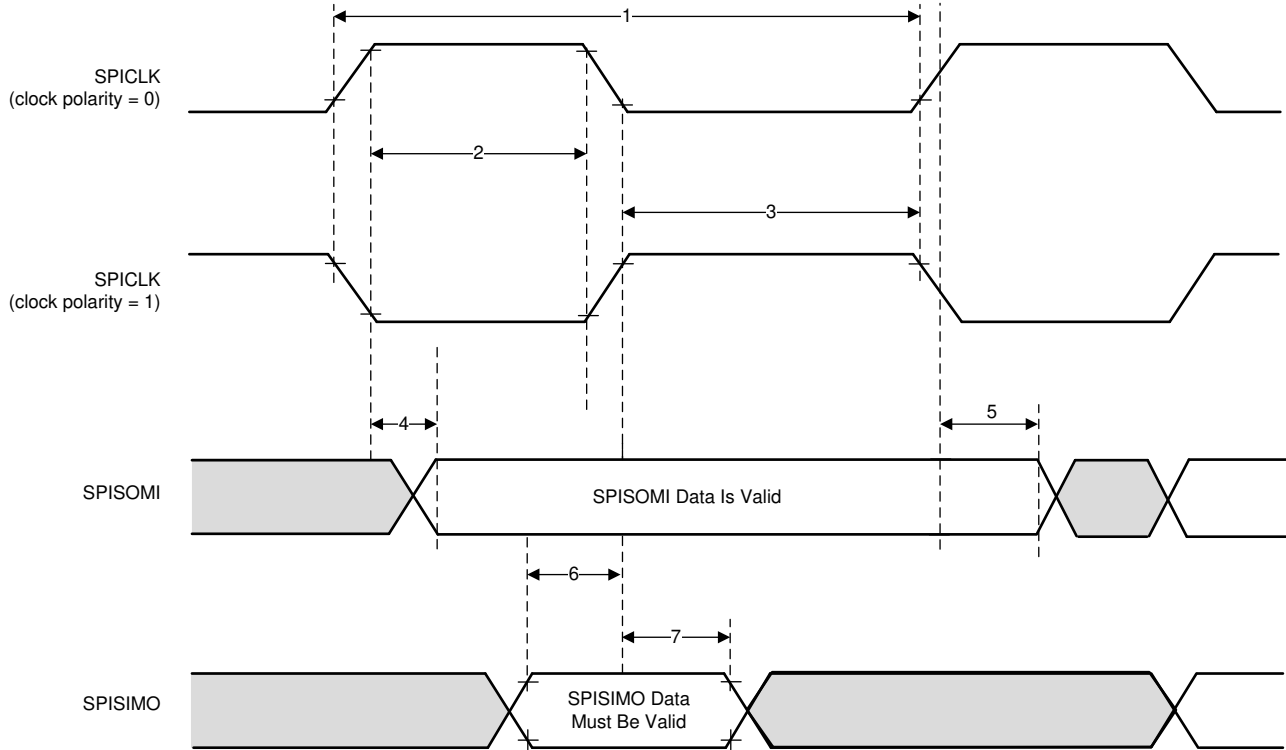

Figure 7-10. SPI Peripheral Mode External Timing (CLOCK PHASE = 0)

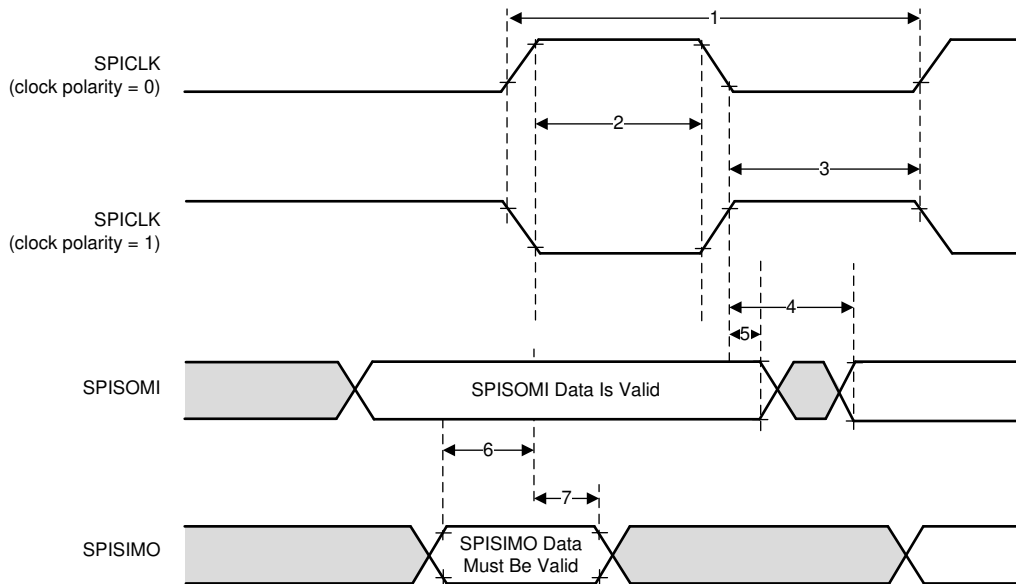

Figure 7-11. SPI Peripheral Mode External Timing (CLOCK PHASE = 1)

7.12.3 Ethernet Switch (RGMII/RMII/MII) Peripheral

The device integrates a two port Ethernet with one external RGMII/RMII/MII port and another port servicing the Main Sub-System (MSS). This interface is intended to operate primarily as a 1Gbps ECU interface. It can also be used as an instrumentation interface.

- Full Duplex 10Mbps/100Mbps/1Gbps wire rate interface to Ethernet PHY over RGMII, RMII, or MII parallel interface
- MDIO Clause 22 and 45 PHY management interface
- IEEE 1588 Synchronous Ethernet support
- CPTS based radar frame triggering, allowing Ethernet to trigger radar frames

7.12.3.1 RGMII/RMII/MII Timing Conditions

SPECIFICATION NUMBER	PARAMETER	MIN	TYP	MAX	UNIT
Input Conditions					
1	SR _i Input Slew Rate	2.64		5	V/ns
Output Conditions					
3	C _{LOAD} Output load capacitance	2		20	pF

7.12.3.2 RGMII Transmit Clock Switching Characteristics

PARAMETER	DESCRIPTION	SPEED	MIN	MAX	UNIT
t _c (TXC)	Cycle time, rgmiin_txc	10Mbps	360	440	ns
		100Mbps	36	44	ns
		1Gbps	7.6	8.4	ns
t _w (TXCH)	Pulse duration, rgmiin_txc high	10Mbps	160	240	ns
		100Mbps	16	24	ns
		1Gbps	3.6	4.4	ns
t _w (TXCL)	Pulse duration, rgmiin_txc low	10Mbps	160	240	ns
		100Mbps	16	24	ns
		1Gbps	3.6	4.4	ns
t _t (TXC)	Transition time, rgmiin_txc	10Mbps		1.4	ns
		100Mbps		1.4	ns
		1Gbps		0.75	ns

7.12.3.3 RGMII Transmit Data and Control Switching Characteristics

PARAMETER	DESCRIPTION	MODE	MIN	MAX	UNIT
t _{osu} (TXD-TXC)	Output Setup time, transmit selected signals valid to MSS_RGMII_TCLK high/low	RGMII, Internal Delay Enabled, 10M/100M/1G	1.2		ns
t _{oh} (TXC-TXD)	Output Hold time, transmit selected signals valid after MSS_RGMII_TCLK high/low	RGMII, Internal Delay Enabled, 10M/100M/1G	1.2		ns

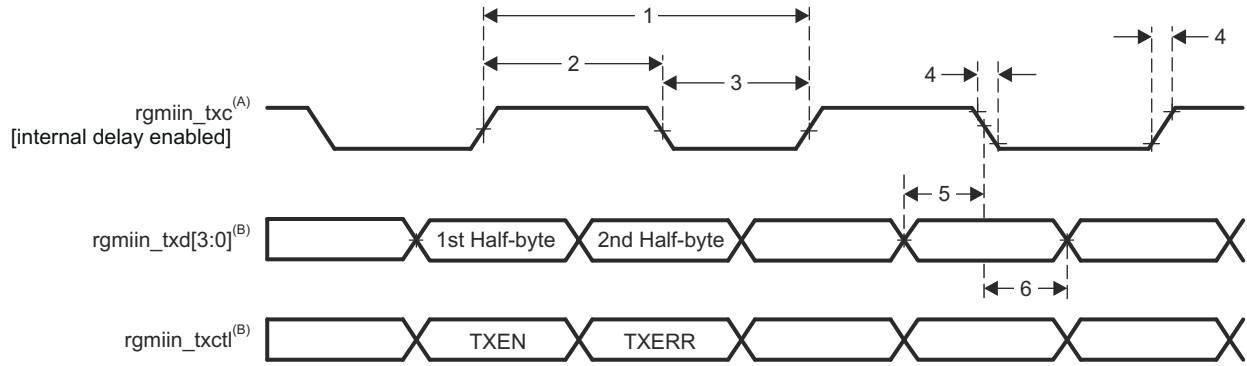

- A. TXC is delayed internally before being driven to the rgmiin_txc pin. This internal delay is always enabled.
- B. Data and control information is transmitted using both edges of the clocks. rgmiin_txd[3:0] carries data bits 3-0 on the rising edge of rgmiin_txc and data bits 7-4 on the falling edge of rgmiin_txc. Similarly, rgmiin_txctl carries TXEN on rising edge of rgmiin_txc and TXERR of falling edge of rgmiin_txc.

Figure 7-12. RGMII Transmit Interface Switching Characteristics

7.12.3.4 RGMII Receive Clock Timing Requirements

PARAMETER	DESCRIPTION	SPEED	MIN	MAX	UNIT
t _c (RXC)	Cycle time, rgmiin_rxc	10Mbps	360	440	ns
		100Mbps	36	44	ns
		1Gbps	7.6	8.4	ns
t _w (RXCH)	Pulse duration, rgmiin_rxc high	10Mbps	160	240	ns
		100Mbps	16	24	ns
		1Gbps	3.6	4.4	ns
t _w (RXCL)	Pulse duration, rgmiin_rxc low	10Mbps	160	240	ns
		100Mbps	16	24	ns
		1Gbps	3.6	4.4	ns
t _t (RXC)	Transition time, rgmiin_rxc	10Mbps		1.4	ns
		100Mbps		1.4	ns
		1Gbps		0.75	ns

7.12.3.5 RGMII RX and TX Timing Diagrams

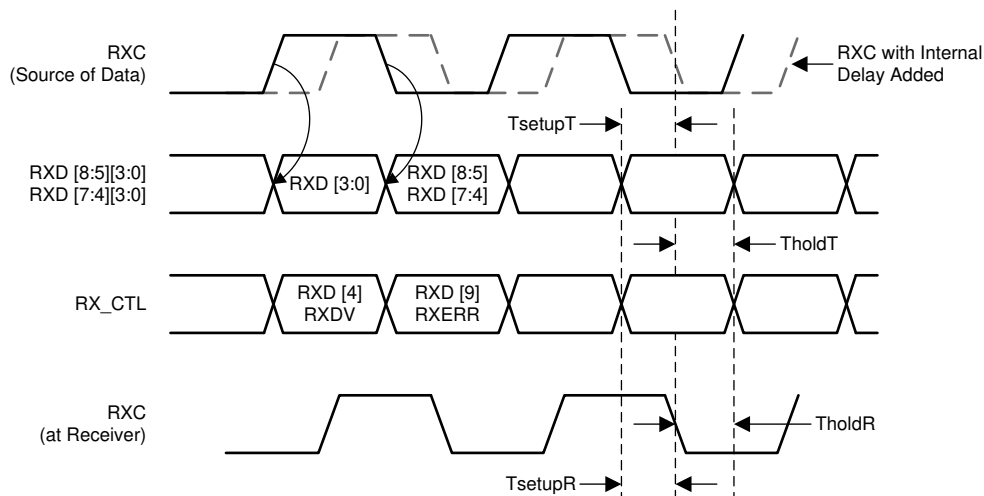

Figure 7-13. RGMII RX Timing Diagram

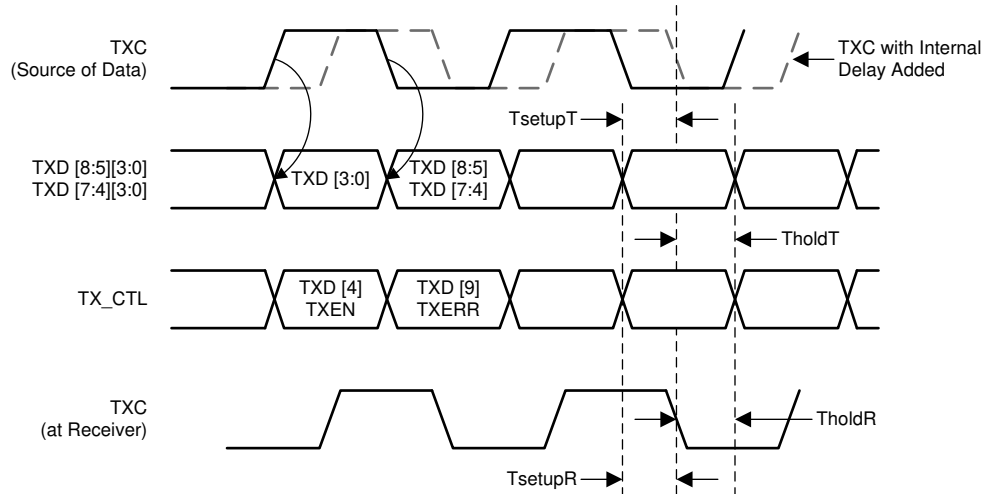

Figure 7-14. RGMII TX Timing Diagram

Table 7-7.

TX Mode	RX Mode	TX Delay	RX Delay	Loopback Testcase	Comment
Aligned	Aligned	0.250 ns	0.250 ns	RXCRC errors, RXAlignCode Errors at MAC port	
Aligned	Aligned	0.500 ns	0.500 ns	RXCRC errors, RXAlignCode Errors at MAC port	
Aligned	Shift	0.250 ns	0.250 ns	Passed: No Packet drops at MAC port	
Aligned	Shift	0.250 ns	2 ns	Passed: No packet drops at MAC port.	This is the TI recommended settings
Aligned	Aligned	0.250 ns	0.500 ns	RXCRC errors, RXAlignCode Errors at MAC port	

7.12.3.6 RGMII Receive Data and Control Timing Requirements

PARAMETER	DESCRIPTION	MIN	MAX	UNIT
$t_{su}(RXD-RXCH)$	Setup time, receive selected signals valid before MSS_RGMII_RCLK high/low	1.25		ns
$t_h(RXCH-RXD)$	Hold time, receive selected signals valid after MSS_RGMII_RCLK high/low	1.25		ns

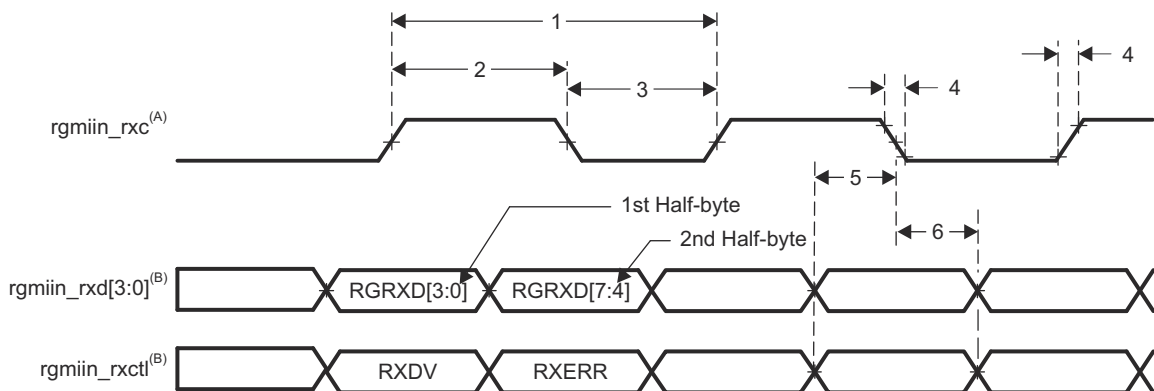

A. rgmiin_rxc must be externally delayed relative to the data and control pins.

- B. Data and control information is received using both edges of the clocks. MSS_RGMII_RXD[3:0] carries data bits 3-0 on the rising edge of rgmiin_rxc and data bits 7-4 on the falling edge of frgmiin_rxc. Similarly, rgmiin_rxcctl carries RXDV on rising edge of rgmiin_rxc and RXERR on falling edge of rgmiin_rxc.

Figure 7-15. MAC Receive Interface Timing, RGMII operation

7.12.3.7 RMI Transmit Clock Switching Characteristics

PARAMETER	DESCRIPTION	MIN	MAX	UNIT
$t_{c(REF_CLK)}$	Cycle time, REF_CLK	20		ns
$t_{w(REF_CLKH)}$	Pulse duration, REF_CLK high	7	13	ns
$t_{w(REF_CLKL)}$	Pulse duration, REF_CLK low	7	13	ns
$t_{t(REF_CLK)}$	Transition time, REF_CLK		3	ns

7.12.3.8 RMI Transmit Data and Control Switching Characteristics

PARAMETER	DESCRIPTION	MIN	MAX	UNIT
$t_{d(REF_CLK-TXD)}$	Delay time, REF_CLK high to selected transmit signals valid	2	14.2	ns
$t_{dd(REF_CLK-TXEN)}$				

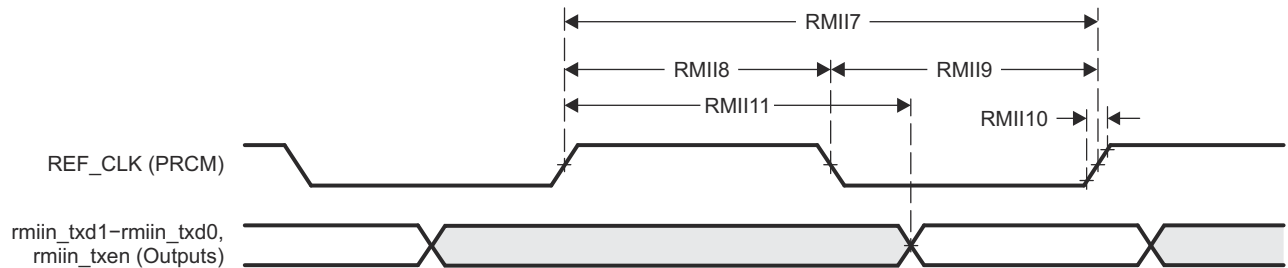

SPRS8xx_GMAC_RMII_TX_06

Figure 7-16. MAC Transmit Interface Timing, RMI operation

7.12.3.9 RMI Receive Clock Timing Requirements

PARAMETER	DESCRIPTION	MIN	MAX	UNIT
$t_{c(REF_CLK)}$	Cycle time, REF_CLK	20		ns
$t_{w(REF_CLKH)}$	Pulse duration, REF_CLK high	7	13	ns
$t_{w(REF_CLKL)}$	Pulse duration, REF_CLK low	7	13	ns
$t_{tt(REF_CLK)}$	Transition time, REF_CLK		3	ns

7.12.3.10 RMI Receive Data and Control Timing Requirements

PARAMETER	DESCRIPTION	MIN	MAX	UNIT
$t_{su(RXD-REF_CLK)}$	Setup time, receive selected signals valid before REF_CLK	4		ns
$t_{su(CRS_DV-REF_CLK)}$				
$t_{su(RX_ER-REF_CLK)}$				
$t_h(REF_CLK-RXD)$	Hold time, receive selected signals valid after REF_CLK	2		ns
$t_h(REF_CLK-CRS_DV)$				
$t_h(REF_CLK-RX_ER)$				

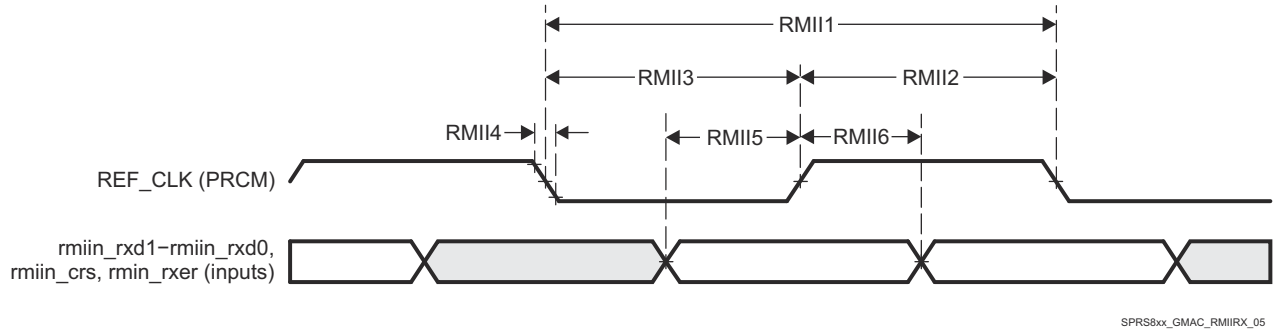

Figure 7-17. MAC Receive Interface Timing, RMII operation

7.12.3.11 MII Transmit Switching Characteristics

PARAMETER	DESCRIPTION	MIN	MAX	UNIT
$t_{d(TX_CLK-TXD)}$	Delay time, miin_txclk to transmit selected signals valid	0	25	ns
$t_{d(TX_CLK-TX_EN)}$				
$t_{d(TX_CLK-TX_ER)}$				

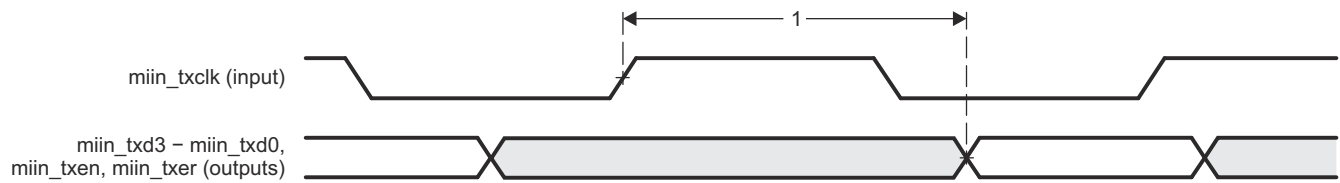

Figure 7-18. MAC Transmit Interface Timing, MII operation

7.12.3.12 MII Receive Clock Timing Requirements

PARAMETER	DESCRIPTION	SPEED	MIN	MAX	UNIT
$t_c(RX_CLK)$	Cycle time, miin_rxclk	10 Mbps	400		ns
		100 Mbps	40		ns
$t_w(RX_CLKH)$	Pulse duration, miin_rxclk high	10 Mbps	140	260	ns
		100 Mbps	14	26	ns
$t_w(RX_CLKL)$	Pulse duration, miin_rxclk low	10 Mbps	140	260	ns
		100 Mbps	14	26	ns
$t_t(RX_CLK)$	Transition time, miin_rxclk	10 Mbps		3	ns
		100 Mbps		3	ns

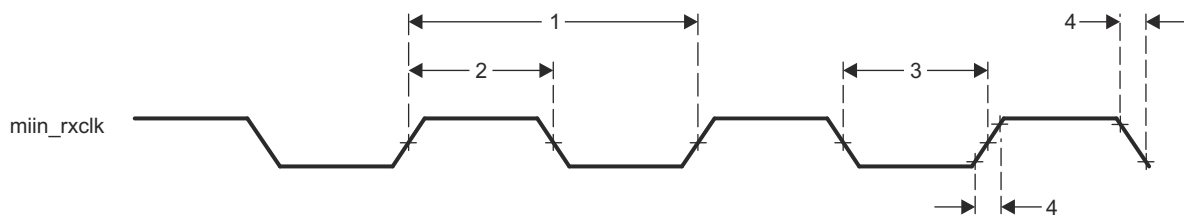

Figure 7-19. Clock Timing (MAC Receive) - MII operation

7.12.3.13 MII Receive Timing Requirements

PARAMETER	DESCRIPTION	MIN	MAX	UNIT
$t_{su}(RXD-RX_CLK)$	Setup time, receive selected signals valid before miin_rxclk	8		ns
$t_{su}(RX_DV-RX_CLK)$				
$t_{su}(RX_ER-RX_CLK)$				
$t_h(RX_CLK-RXD)$	Hold time, receive selected signals valid after miin_rxclk	8		ns
$t_h(RX_CLK-RX_DV)$				
$t_h(RX_CLK-RX_ER)$				

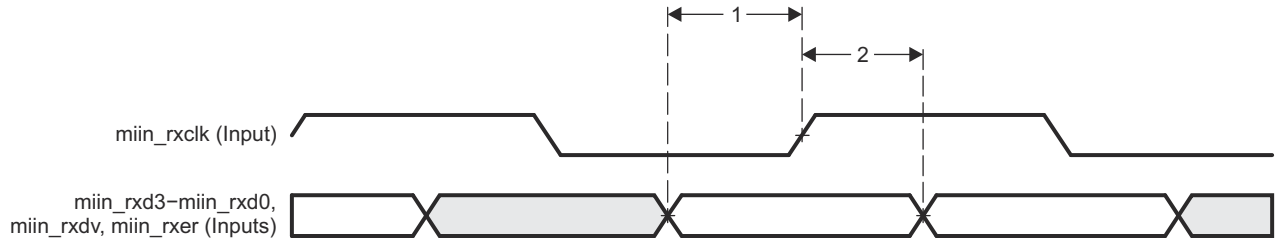

Figure 7-20. MAC Receive Interface Timing, MIIn operation

7.12.3.14 MII Transmit Clock Timing Requirements

PARAMETER	DESCRIPTION	SPEED	MIN	MAX	UNIT
$t_c(TX_CLK)$	Cycle time, miin_txclk	10Mbps	400		ns
		100Mbps	40		ns
$t_w(TX_CLKH)$	Pulse duration, miin_txclk high	10Mbps	140	260	ns
		100Mbps	14	26	ns
$t_w(TX_CLKL)$	Pulse duration, miin_txclk low	10Mbps	140	260	ns
		100Mbps	14	26	ns
$t_t(TX_CLK)$	Transition time, miin_txclk	10Mbps		3	ns
		100Mbps		3	ns

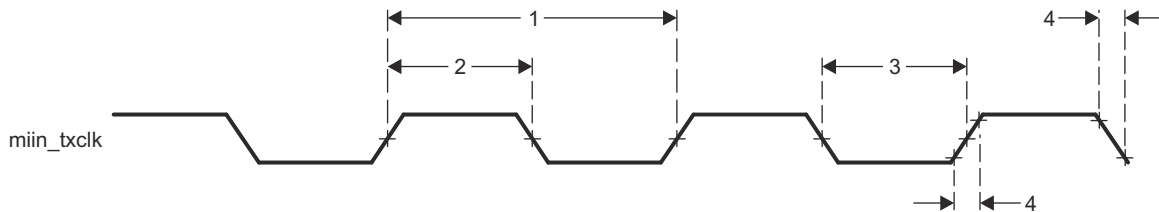

Figure 7-21. Clock Timing (MAC Transmit) - MIIn operation

7.12.3.15 MDIO Interface Timings

CAUTION

The IO Timings provided in this section are only valid for some MAC usage modes when the corresponding Virtual IO Timings or Manual IO Timings are configured as described in the tables found in this section.

Table 7-8, Table 7-9 and Figure 7-22 present switching characteristics and timing requirements for the MDIO interface.

Table 7-8. Timing Requirements for MDIO Input

PARAMETER	DESCRIPTION	MIN	MAX	UNIT
$t_{c(MDC)}$	Cycle time, MDC	40		ns
$t_{w(MDCH)}$	Pulse Duration, MDC High	16		ns
$t_{w(MDCL)}$	Pulse Duration, MDC Low	16		ns
$t_{su(MDIO-MDC)}$	Setup time, MDIO valid before MDC High	9		ns
$t_{h(MDIO_MDC)}$	Hold time, MDIO valid from MDC High	0		ns

Table 7-9. Switching Characteristics Over Recommended Operating Conditions for MDIO Output

PARAMETER	DESCRIPTION	MIN	MAX	UNIT
$t_t(MDC)$	Transition time, MDC		3	ns
$t_d(MDC-MDIO)$	Delay time, MDC low to MDIO valid	10	$(P * 0.5) - 10$	ns

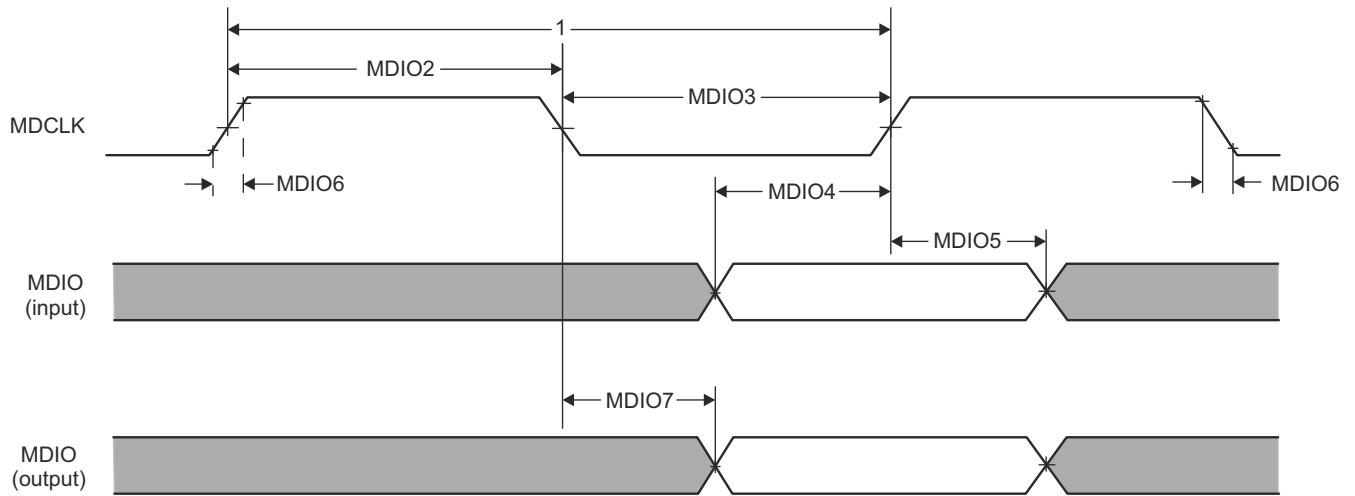

Figure 7-22. MAC MDIO diagrams

7.12.4 LVDS Instrumentation and Measurement Peripheral

The device supports a set of LVDS interfaces in two different modes.

- Legacy LVDS mode

The LVDS IO are shared between the above two measurement interface options.

Following features are supported :

- 2-data lane LVDS interface (two additional lanes for Data Clock and Frame Clock)

Please see the device TRM for information regarding programming options for LVDS interface.

7.12.4.1 LVDS Interface Configuration

The supported LVDS lane configuration is 2-data lane (LVDS_TXP/M), one Bit Clock lane (LVDS__TXxx_CLKP/M) and one Frame clock lane (LVDS_TXxx_FRCLKP/M). The LVDS interface supports programmable data rates with the maximum being 900 Mbps (450 MHz DDR Clock).

Note that the bit clock is in DDR format and hence the number of toggles in the clock is equivalent to data.

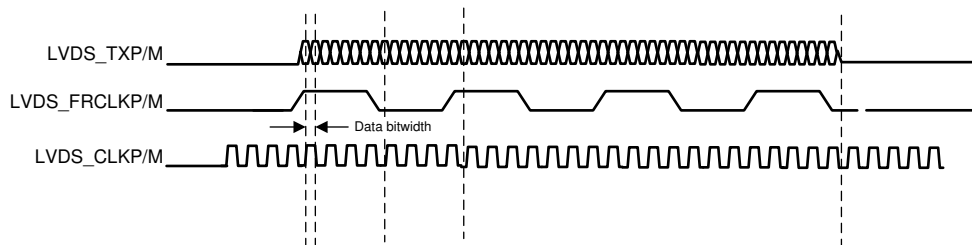

Figure 7-23. LVDS Interface Lane Configuration And Relative Timings

7.12.4.2 LVDS Interface Timings

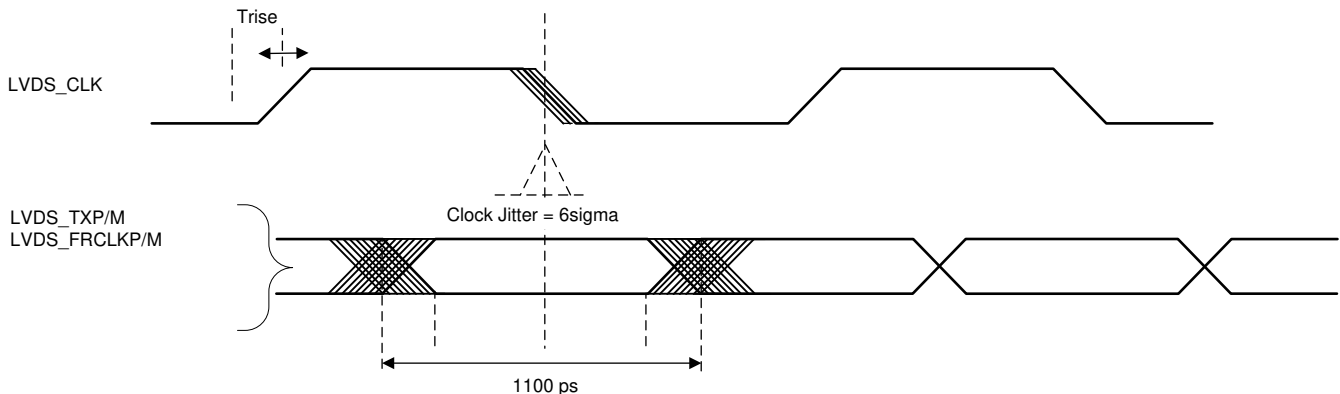

Figure 7-24. Timing Parameters

Table 7-10. LVDS Electrical Characteristics

PARAMETER	TEST CONDITIONS	MIN	TYP	MAX	UNIT
Duty Cycle Requirements	max 1pF lumped capacitive load on LVDS lanes	48%		52%	
Output Differential Voltage	peak-to-peak single-ended with 100 Ω resistive load between differential pairs	250		450	mV
Output Offset Voltage		1125		1275	mV
Trise and Tfall	20%-80%, 900 Mbps		330		ps
Jitter (pk-pk)	900 Mbps		80		ps

7.12.5 UART Peripheral

The device includes two UART interfaces. One UART is intended as a secondary boot loader source and the other one is intended for use as a register debug interface (with XDS110 emulator).

- Maximum baud-rate supported shall be at least 1536kBaud in all the different clock frequency modes
- UART interfaces multiplexed with other I/O to allow for widest peripheral use flexibility

7.12.5.1 SCI Timing Requirements

	MIN	TYP	MAX	UNIT
f(baud)		921.6		kHz

7.12.6 Inter-Integrated Circuit Interface (I2C)

The device supports one Controller/Target Inter-integrated Circuit interface and is intended to be connected to an external PMIC or EEPROM device (alternative control SPI).

The I2C has the following features:

- Standard/fast mode I2C interface compliant with I2C bus specification ([UM10204](#))
 - Bit/Byte format transfer
 - 7-bit and 10-bit device addressing modes
 - General call
 - START byte
 - Multi-controller transmitter/ target receiver mode
 - Multi-controller receiver/ target transmitter mode
 - Combined controller transmit/receive and receive/transmit mode
 - Transfer rates up to 400kbps
- Free data format
- Two DMA events (transmit and receive)
- DMA event enable/disable capability
- Module enable/disable capability
- The SDA and SCL are optionally configurable as general purpose I/O
- Slew rate control of the outputs
- Open drain control of the outputs
- Programmable pullup/pulldown capability on the inputs
- Supports Ignore NACK mode

Note

This I2C module does not support:

- Fast-mode Plus or High speed (Hs)mode
- C-bus compatibility mode
- The combined format in 10-bit address mode (the I2C sends the target address second byte every time it sends the target address first byte)

7.12.6.1 I2C Timing Requirements ⁽¹⁾

PARAMETER	DESCRIPTION	STANDARD MODE		FAST MODE		UNIT
		MIN	MAX	MIN	MAX	
f _{SCL}	SCL clock frequency	0	100	0	400	kHz
t _{su} (SCLH-SDAL)	Setup time, SCL high before SDA low (for a repeated START condition)	4.7		0.6		µs
t _h (SCLL-SDAL)	Hold time, SCL low after SDA low (for a START and a repeated START condition)	4		0.6		µs
t _w (SCLL)	Pulse duration, SCL low	4.7		1.3		µs

7.12.7 Enhanced Pulse-Width Modulator (ePWM)

The device includes three Enhanced Pulse-Width Modulation (ePWM) modules. These modules can be used to generate duty-cycled controlled waveforms for a power regulator, or a power management systems, or more complex waveforms for motor control applications.

The module supports the following features:

- Dedicated 16-bit time-base counter with period and frequency control for each PWM module
- Each module contains two PWM outputs (EPWMxA and EPWMxB) that shall be usable in the following configurations:
 - Two independent PWM outputs with single-edge operation
 - Two independent PWM outputs with dual-edge symmetric operation
 - One independent PWM output with dual-edge asymmetric operation

7.12.8 General-Purpose Input/Output

Section 7.12.8.1 lists the switching characteristics of output timing relative to load capacitance.

7.12.8.1 Switching Characteristics for Output Timing versus Load Capacitance (C_L) ⁽¹⁾ ⁽²⁾

PARAMETER	DESCRIPTION	TEST CONDITIONS	VIOIN = 1.8V	VIOIN = 3.3V	UNIT	
t_r	Max rise time	Slew control = 0	$C_L = 20$ pF	2.8	3.0	ns
			$C_L = 50$ pF	6.4	6.9	
			$C_L = 75$ pF	9.4	10.2	
t_f	Max fall time		$C_L = 20$ pF	2.8	2.8	ns
			$C_L = 50$ pF	6.4	6.6	
			$C_L = 75$ pF	9.4	9.8	
t_r	Max rise time	Slew control = 1	$C_L = 20$ pF	3.3	3.3	ns
			$C_L = 50$ pF	6.7	7.2	
			$C_L = 75$ pF	9.6	10.5	
t_f	Max fall time		$C_L = 20$ pF	3.1	3.1	ns
			$C_L = 50$ pF	6.6	6.6	
			$C_L = 75$ pF	9.6	9.6	

- (1) Slew control, which is configured by PADxx_CFG_REG, changes behavior of the output driver (faster or slower output slew rate).
 (2) The rise/fall time is measured as the time taken by the signal to transition from 10% and 90% of VIOIN voltage.

7.13 Emulation and Debug

7.13.1 Emulation and Debug Description

7.13.2 JTAG Interface

The JTAG interface implements the IEEE1149.1 standard interface for processor debug and boundary scan testing.

Section 7.13.2.1 and Section 7.13.2.2 assume the operating conditions stated in Figure 7-26.

7.13.2.1 Timing Requirements for IEEE 1149.1 JTAG

Table 7-11. JTAG Timing Conditions

PARAMETER	DESCRIPTION	MIN	TYP	MAX	UNIT
t_R	Input rise time	1		3	ns
t_F	Input fall time	1		3	ns
C_{LOAD}	Output load capacitance	2		15	pF

Table 7-12. JTAG Timing Requirements

PARAMETER	DESCRIPTION	MIN	TYP	MAX	UNIT
$t_c(TCK)$	Cycle time TCK	33.33			ns
$t_w(TCKH)$	Pulse duration TCK high (40% of t_c)	13.33			ns
$t_w(TCKL)$	Pulse duration TCK low (40% of t_c)	13.33			ns
$t_{su}(TDI-TCK)$	Input setup time TDI valid to TCK high	2.5			ns
$t_{su}(TMS-TCK)$	Input setup time TMS valid to TCK high	2.5			ns
$t_h(TCK-TDI)$	Input hold time TDI valid from TCK high	18			ns
$t_h(TCK-TMS)$	Input hold time TMS valid from TCK high	18			ns

7.13.2.2 Switching Characteristics for IEEE 1149.1 JTAG

PARAMETER	DESCRIPTION	MIN	TYP	MAX	UNIT
$t_d(TCKL-TDOV)$	Delay time, TCK low to TDO valid	0		21	ns

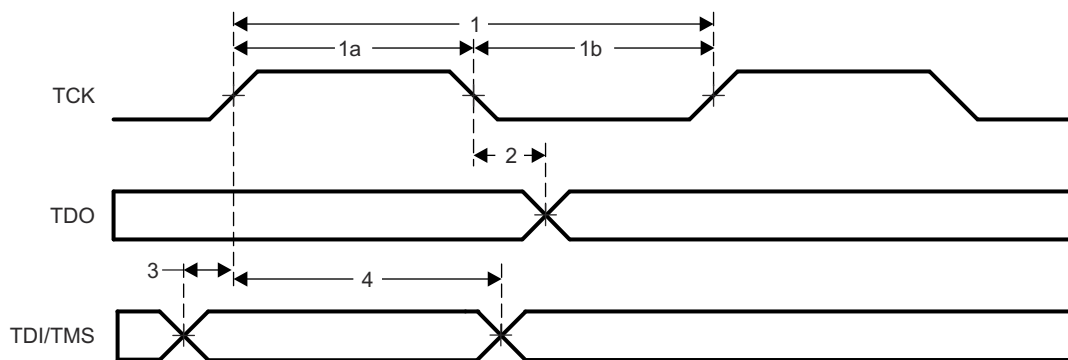

SPRS91v_JTAG_01

Figure 7-26. JTAG Timing

7.13.3 ETM Trace Interface

The ETM Trace interface provides a means of exporting real time processor debug information to a host PC through a compatible emulator toolset.

Section 7.13.3.1 and Section 7.13.3.2 describe the operating conditions shown in Figure 7-27 and Figure 7-28.

7.13.3.1 ETM TRACE Timing Requirements

PARAMETER	DESCRIPTION	MIN	TYP	MAX	UNIT
C _{LOAD}	Output load capacitance	2		20	pF

7.13.3.2 ETM TRACE Switching Characteristics

PARAMETER	DESCRIPTION	MIN	TYP	MAX	UNIT
t _{cyc(ETM)}	Cycle time, TRACECLK period	16			ns
t _{h(ETM)}	Pulse Duration, TRACECLK High	7			ns
t _{l(ETM)}	Pulse Duration, TRACECLK Low	7			ns
t _{r(ETM)}	Clock and data rise time			3.3	ns
t _{f(ETM)}	Clock and data fall time			3.3	ns
t _{d(ETMTRACECLKH-ETMDATAV)}	Delay time, ETM trace clock high to ETM data valid	1		14.5	ns
t _{d(ETMTRACECLKL-ETMDATAV)}	Delay time, ETM trace clock low to ETM data valid	1		14.5	ns

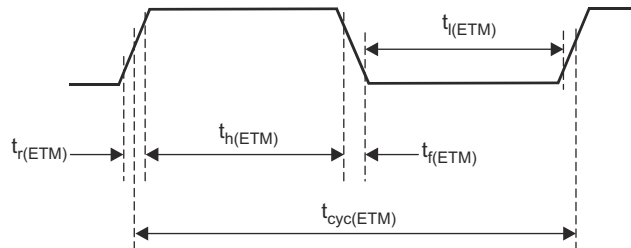

Figure 7-27. ETMTRACECLKOUT Timing

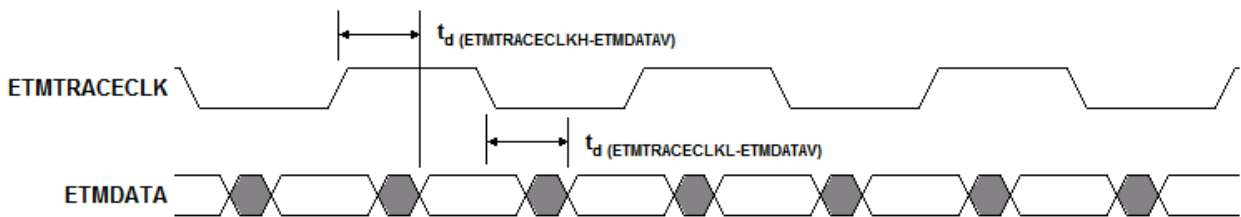

Figure 7-28. ETMDATA Timing

8 Detailed Description

8.1 Overview

The AWR2544 device includes the entire Millimeter Wave blocks, and analog baseband signal chain, for four transmitters and four receivers, as well as a customer-programmable MCU. The device comes with an additional Launch on package (LOP) antenna feature which facilitates the attachment of antennas directly on to the package..

8.2 Functional Block Diagram

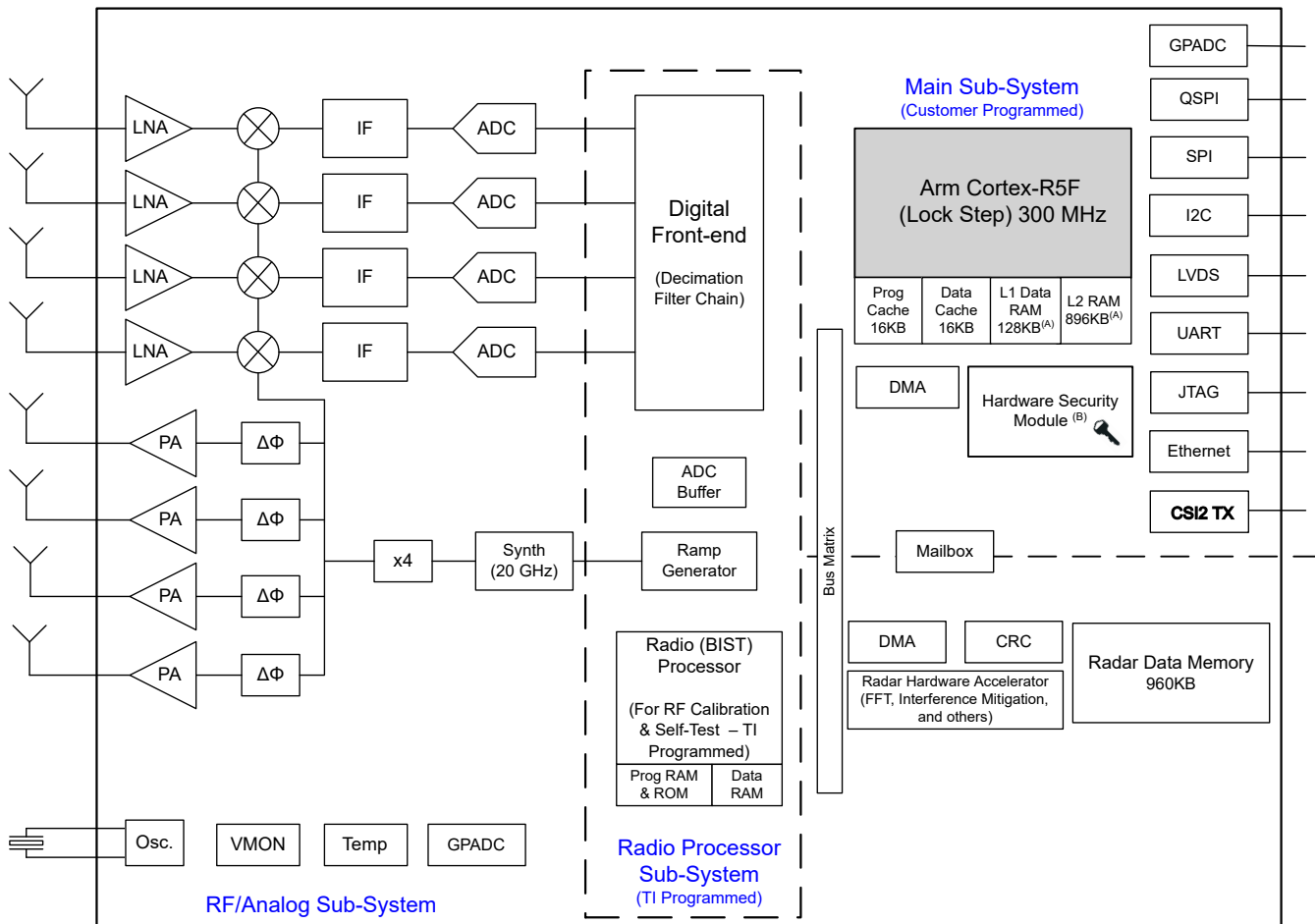

Figure 8-1. Functional Block Diagram

8.3 Subsystems

8.3.1 RF and Analog Subsystem

The RF and analog subsystem includes the RF and analog circuitry – namely, the synthesizer, PA, LNA, mixer, IF, and ADC. This subsystem also includes the crystal oscillator and temperature sensors. The four transmit and the receive channels can all be operated simultaneously for transmit beamforming purpose and receiving data as required.

8.3.1.1 RF Clock Subsystem

The device clock subsystem generates 76 to 81GHz from an input reference of 50-MHz crystal. It has a built-in oscillator circuit followed by an Analog PLL and a RF synthesizer circuit. The output of the RF synthesizer is then processed by an x4 multiplier to create the required frequency in the 76 to 81GHz spectrum. The RF synthesizer output can be modulated by the timing engine block to create the required waveforms for effective sensor operation or it can input a fixed signal of 1GHz directly from APLL.

The Analog PLL also provides a reference clock for the host processor after system wakeup.

The clock subsystem also has built-in mechanisms for detecting the presence of a crystal and monitoring the quality of the generated clock.

Figure 8-2 describes the clock subsystem.

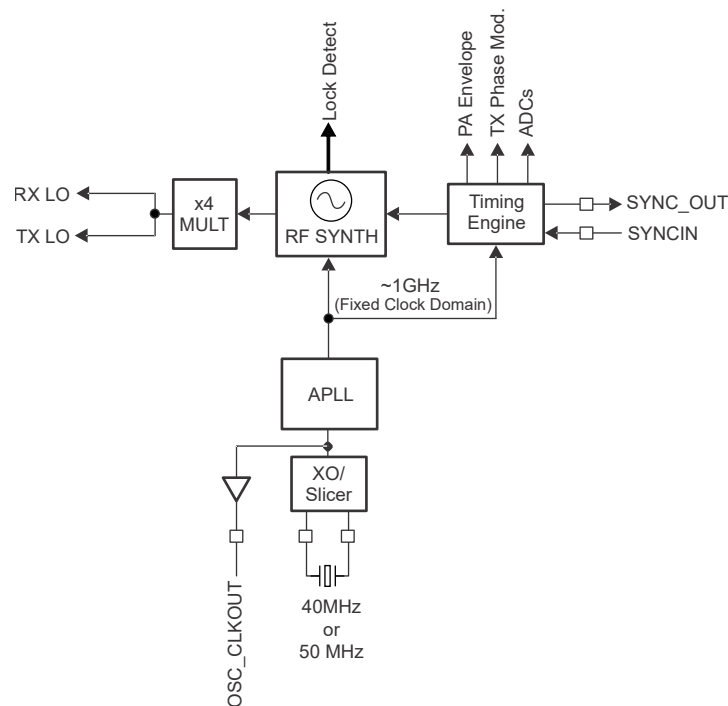

Figure 8-2. RF Clock Subsystem

8.3.1.2 Transmit Subsystem

The device transmit subsystem consists of four parallel transmit chains, each with independent phase and amplitude control. All four transmitters can be used simultaneously or in time-multiplexed fashion. The device supports binary phase modulation and a 6 bit programmable phase shifter for beamforming control on a per chirp basis for each channel as indicated in the figure below. The transmit chains also support programmable backoff for system optimization.

Figure 8-3 describes the transmit subsystem.

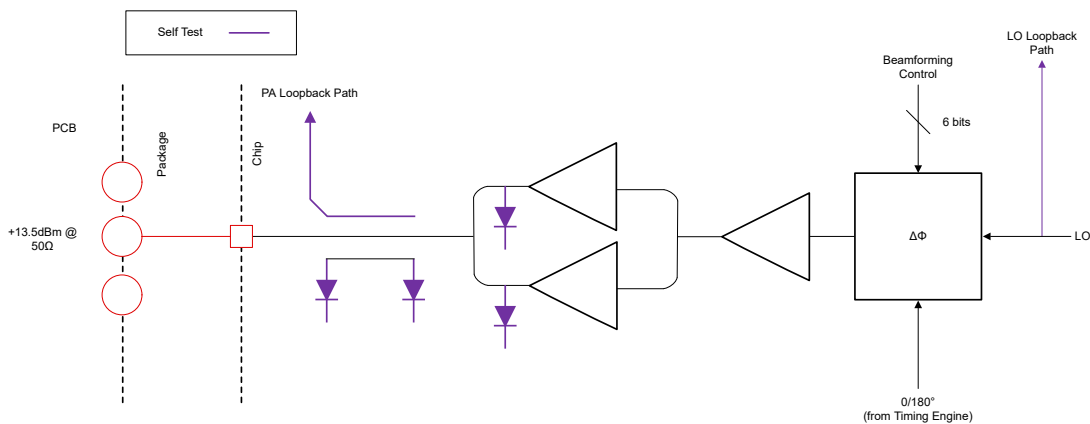

Figure 8-3. Transmit Subsystem (Per Channel)

8.3.1.3 Receive Subsystem

The device receive subsystem consists of four parallel channels. A single receive channel consists of an LNA, mixer, IF filtering, ADC conversion, and decimation. All four receive channels can be operational at the same time. An individual power-down option is also available for system optimization.

The device supports a real-only receiver. The band-pass IF chain has configurable cutoff frequencies above 350 kHz and can support bandwidths up to 20MHz.

Figure 8-4 describes the receive subsystem.

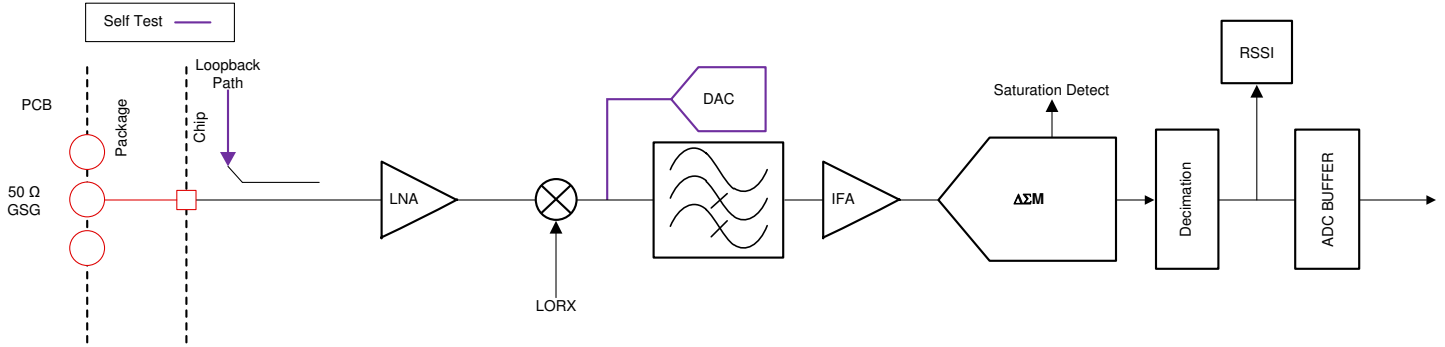

Figure 8-4. Receive Subsystem (Per Channel)

8.3.2 Processor Subsystem

At a high level there is one customer programmable subsystem. The left hand side shows TI's high performance HWA 1.5, a high-bandwidth interconnect for high performance (128-bit, 150 MHz), and associated peripherals – LVDS interface for Measurement data output, L3 Radar data cube memory, ADC buffers, CRC engine, and data handshake memory (additional memory provided on interconnect).

The right side of the diagram shows the Main subsystem (MSS). The Main subsystem, as the name suggests, is the primary controller of the device and controls all the device peripherals and house-keeping activities of the device. The Main subsystem contains a Cortex-R5F (MSS R5F) processor and associated peripherals and housekeeping components such as EDMAs, CRC, and peripherals (I²C, UART, SPI, EPWM, and others) connected to the primary interconnect through the Peripheral Central Resource (PCR interconnect).

The Radio Processing Subsystem or the BIST Subsystem (RSS) is responsible for initializing and calibrating the Analog/RF modules. RSS periodically monitors the Analog/RF functionality such that all the Analog/RF modules work in their defined limits.

General-Purpose ADC (GPADC), Fast Fourier Transformation engine (FFT engine) and other modules are provided to monitor the signal from different points in the transmitter and receiver chains. Digital front-end filters (DFE), Ramp Generation module and Analog/DFE registers, which are mainly under the control of BSS, can be indirectly controlled through the API calls from the Main Subsystem.

Refer to the AWR2544 TRM (Technical Reference Manual) for MSS Cortex-R5F.

8.3.3 Automotive Interfaces

The device communicates with the automotive network over the following main interface:

- Ethernet

8.4 Other Subsystems

8.4.1 Hardware Accelerator Subsystem

The device incorporates Radar Hardware Accelerators (HWA1.5) to compress range FFT data for efficient Ethernet transfer and to offload the central radar processor.

To understand the capabilities offered by the Radar Hardware Accelerator 1.5 so as to achieve the desired functionality, please refer to the Hardware Accelerator 1.5 section in the Device Technical Reference Manual.

8.4.2 Security – Hardware Security Module

A Hardware Security Module (HSM), which performs a secure zone operation, is provisioned in the device (*operational only in select part variants*). A programmable Arm Cortex-M4 core is available to implement the crypto-agility requirements.

The cryptographic algorithms can be accelerated using the hardware modules in the HSM. Functions include acceleration of AES, SHA, and public key accelerator (PKA) to perform math operations for asymmetric key cryptographic requirements and true random number generation.

The Main subsystem (MSS) Cortex-R5F processor interfaces with the HSM subsystem to perform the cryptographic operations required for the secure boot and secure runtime communications.

Further details on Security can be found in the concerned collaterals. Please reach out to your local TI sales representative for more information.

8.4.3 ADC Channels (Service) for User Application

The device includes provision for an ADC service for user application, where the GPADC engine present inside the device can be used to measure up to nine external and internal voltages. The ADC1, ADC2, ADC5, and ADC6 pins are used for this purpose.

Note

GPADC structures are also used for measuring the output of internal temperature sensors.

GPADC Specifications:

- 625 Ksps SAR ADC
- 0 to 1.8V input range
- 10-bit resolution

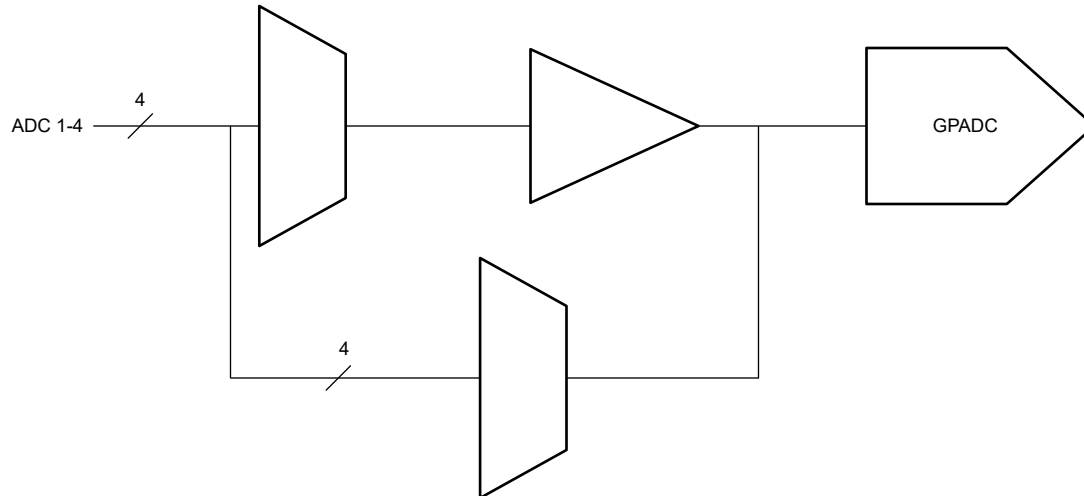

Table 8-1. GP-ADC Parameter

PARAMETER	TYP	UNIT
ADC supply	1.8	V
ADC unbuffered input voltage range	0 – 1.8	V
ADC buffered input voltage range ⁽¹⁾	0.4 – 1.3	V
ADC resolution	10	bits
ADC offset error	±5	LSB
ADC gain error	±5	LSB
ADC DNL	-1/+2.5	LSB
ADC INL	±2.5	LSB
ADC sample rate	625	Ksps
ADC sampling time	400	ns
ADC internal cap	10	pF
ADC buffer input capacitance	2	pF
ADC input leakage current	3	uA

(1) Outside of given range, the buffer output will become nonlinear.

9 Monitoring and Diagnostics

9.1 Monitoring and Diagnostic Mechanisms

Table 9-1 is a list of the main monitoring and diagnostic mechanisms available in the device.

Table 9-1. Monitoring and Diagnostic Mechanisms for AWR2544

FEATURE	DESCRIPTION
MAIN SUBSYSTEM	
Lockstep operation of MSS R5F Core	Device architecture supports lockstep operation of the MSS R5F core that is the operating core in the Main subsystem that is provisioned as the safety island in the device.
Boot time LBIST For MSS R5F Core and associated VIM	Device architecture supports hardware logic BIST (LBIST) engine self-test Controller (STC). This logic is used to provide a very high diagnostic coverage (>90%) on the MSS R5F CPU core and Vectored Interrupt Module (VIM) at a transistor level. LBIST for the CPU and VIM need to be triggered by application code before starting the functional safety application. A reset of the CPU is initiated at the end of the STC operation and the reset cause register captures the status of reset. The STC registers can then be read out to identify the status of the STC execution to determine if there were any errors. CPU stays there in while loop and does not proceed further if a fault is identified. There can be a fault injection test also performed which leads to a reset of the CPU with the error status signaled in the STC registers.
Boot time PBIST for MSS R5F Memories	MSS R5F has tightly coupled memories (TCM) Level 1 (L1) memories TCMA, TCMB0 and TCMB1 as well as the level 2 (L2) memories. Device architecture supports a hardware programmable memory BIST (PBIST) engine. This logic is used to provide a very high diagnostic coverage (March-13n) on the implemented MSS R5F TCMs at a transistor level. PBIST for L1 and L2 memories is triggered by the bootloader at the boot time before starting download of application from flash or a peripheral interface. The CPU is in a while loop and does not proceed further if a fault is identified.
End to End ECC for MSS R5F Memories	The TCMs and L2 memory diagnostic support a single error correction, double error detection (SECEDED) ECC diagnostic. For L2 memory, an 8-bit code word is used to store the ECC data as calculated over the 64-bit data bus. For TCMs, a 7-bit code word is used to store the ECC data for a 32-bit data bus. ECC evaluation for TCMs is done by the ECC control logic inside the CPU. This scheme provides end-to-end diagnostics on the transmissions between CPU and TCM. CPU can be configured to have predetermined response (ignore or abort generation) to single and double bit error conditions.
MSS R5F bit multiplexing	Logical TCM and L2 memory word and the associated ECC code is split and stored in two physical SRAM banks. This scheme provides an inherent diagnostic mechanism for address decode failures in the physical SRAM banks. Faults in the bank addressing are detected by the CPU as an ECC fault. Further, bit multiplexing scheme is implemented such that the bits accessed to generate a logical (CPU) word are not physically adjacent. This scheme helps to reduce the probability of physical multi-bit faults resulting in logical multi-bit faults; rather the faults manifest as multiple single bit faults. As the SECEDED TCM ECC can correct a single bit fault in a logical word, this scheme improves the usefulness of the TCM ECC diagnostic. Both these features are hardware features and cannot be enabled or disabled by application software.
Clock Monitor	Device architecture supports four digital clock comparators (EDCCs) and an internal RCOSC. Dual functionality is provided by these modules – clock detection and clock monitoring. EDCCA is dedicated for ADPLL/APLL lock detection monitoring, comparing the ADPLL/APLL output divided version with the Reference input clock of the device. Failure detection for EDCCA can be programmed to cause the device to go into limp mode. Additionally, there is a provision to feed an external reference clock to monitor the internal clock using the EDCCA. EDCCB, EDCCC, EDCCD module is one which is available for user software. Any two clocks can be compared. One example is to compare the CPU clock with the reference or internal RCOSC clock source. Failure detection is indicated to the MSS R5F CPU through the Error Signaling Module (ESM).

Table 9-1. Monitoring and Diagnostic Mechanisms for AWR2544 (continued)

FEATURE	DESCRIPTION
RTI/WDT for MSS R5F	<p>Device architecture supports the use of an internal watchdog that is implemented in the real-time interrupt (RTI) module. The internal watchdog has two modes of operation: digital watchdog (DWD) and digital windowed watchdog (DWW). The modes of operation are mutually exclusive; the designer can elect to use one mode or the other but not both at the same time.</p> <p>Watchdog can issue either an internal (warm) system reset or a CPU non-mask able interrupt upon detection of a failure.</p> <p>The Watchdog is enabled by the bootloader in DWD mode at boot time to track the boot process. When the application code takes control, the watchdog can be configured again for the mode and timings based on the application requirements.</p>
MPU for MSS R5F	<p>The Cortex-R5F CPU includes an MPU. The MPU logic can be used to provide spatial separation of software tasks in the device memory. The Cortex-R5F MPU supports 16 regions. The operating system controls the MPU and changes the MPU settings based on the needs of each task. A violation of a configured memory protection policy results in a CPU abort.</p>
PBIST for Peripheral interface SRAMs - SPI, Ethernet, EDMA, Mailbox	<p>Device architecture supports a hardware programmable memory BIST (PBIST) engine for Peripheral SRAMs as well.</p> <p>PBIST for peripheral SRAM memories can be triggered by the application. User can elect to run the PBIST on one SRAM or on groups of SRAMs based on the execution time, which can be allocated to the PBIST diagnostic. The PBIST tests are destructive to memory contents, and as such are typically run only at boot time. However, the user has the freedom to initiate the tests at any time if peripheral communication can be hindered.</p> <p>Any fault detected by the PBIST results in an error indicated in PBIST status registers.</p>
ECC for Peripheral interface SRAMs – SPI, Ethernet, EDMA, Mailbox	<p>Peripheral interface SRAMs diagnostic is supported by Single error correction double error detection (SECCDED) ECC diagnostic. When a single or double bit error is detected, the MSS R5F is notified via ESM (Error Signaling Module). This feature is disabled after reset.</p> <p>Software must configure and enable this feature in the peripheral and ESM module. ECC failure (both single bit corrected and double bit uncorrectable error conditions) is reported to the MSS R5F as an interrupt via ESM module.</p>
Configuration registers protection for Main SS peripherals	<p>All the Main SS peripherals (SPI, Ethernet, I2C, DMAs, RTI/WDT, DCCs, EDMA, IOMUX etc.) are connected to interconnect via Peripheral Central resource (PCR). This provides two diagnostic mechanisms that can limit access to peripherals. Peripherals can be clock gated per peripheral chip select in the PCR. This can be utilized to disable unused features such that the features cannot interfere. In addition, each peripheral chip select can be programmed to limit access based on privilege level of transaction. This feature can be used to limit access to entire peripherals to privileged operating system code only.</p> <p>These diagnostic mechanisms are disabled after reset. Software must configure and enable these mechanisms. Protection violation also generates an error that result in abort to MSS R5F or error response to other hosts such as DMAs.</p>
Cyclic Redundancy Check–Main SS	<p>Device architecture supports hardware CRC engine on Main SS implementing the below polynomials.</p> <ul style="list-style-type: none"> • CRC16 CCITT – 0x10 • CRC32 Ethernet – 0x04C11DB7 • CRC64 • CRC 32C – CASTAGNOLI – 0x1EDC6F4 <p>The read operation of the SRAM contents to the CRC can be done by CPU or by DMA. The comparison of results, indication of fault, and fault response are the responsibility of the software managing the test.</p>
MPU	<p>Device architecture supports MPUs on certain peripheral ports in the Main SS that include L2 Memory, PCR peripheral access, QSPI access, R5F AXI-peripheral access. This allows configuring access permissions to these key regions in the Main SS.</p> <p>By default, this control resides with the HSM.</p>
MPU for DMAs	<p>Device architecture supports MPUs on Main SS EDMAs. EDMAs also includes MPUs on both read and writes host ports. EDMA MPUs supports 8 regions. Failure detection by MPU is reported to the core as an interrupt via local ESM.</p>
Interconnect ECC	<p>Device architecture supports hardware based ECC protection mechanisms for transfers over the system interconnect. Since code execution includes instruction fetches from memories hosted on the interconnect, the transfers over the interconnect are designed to be safe by a combination of ECC and redundancy based mechanisms. Any failures detected in the transfers are reported over the ESM interface. This mechanism is enabled by default in HW, for R5F CPU SS only.</p>

Table 9-1. Monitoring and Diagnostic Mechanisms for AWR2544 (continued)

FEATURE	DESCRIPTION
Error Signaling Module	When a diagnostic detects a fault, the error must be indicated. The Device architecture provides aggregation of fault indication from internal monitoring/diagnostic mechanisms using a peripheral logic known as the Error Signaling Module (ESM). The ESM provides mechanisms to classify errors by severity and to provide programmable error response. ESM module is configured by customer application code and specific error signals can be enabled or masked to generate an interrupt (Low/High priority) for the MSS R5F CPU. Device supports Nerror output signal (IO) which can be monitored externally to identify any kind of high severity faults in the design which are not be handled by the R5F.
Temperature Sensor	Device architecture supports various temperature sensors at temperature hotspots in digital across the device that can be monitored by the application using an internal GPADC channel.
Voltage Monitors	Device architecture supports monitoring the supply rails connected to the chip, in conjunction with external voltage monitors.
BIST (Within RADAR SUB-SYSTEM)	
NOTE: BIST is handled by the TI firmware. Refer to the mmWave Interface Control Document (as a part of mmWave-MCUPLUS-SDK package) and safety manual for information on safety mechanisms.	

Note

Refer to the Device Safety Manual or other relevant collaterals for more details on applicability of all diagnostics mechanisms.

10 Applications, Implementation, and Layout

Note

Information in the following Applications section is not part of the TI component specification, and TI does not warrant its accuracy or completeness. TI's customers are responsible for determining suitability of components for their purposes. Customers should validate and test their design implementation to confirm system functionality.

10.1 Application Information

Key device features driving the following applications are:

- Integration of Radar Front End and Programmable MCU
- Launch on Package (LOP) Antenna Interface
- Flexible boot modes: Autonomous application boot using a serial flash or external boot over SPI
- Hardware Security Module
- High speed up to 1Gbps Fast Ethernet Support

10.2 Short and Medium Range Radar

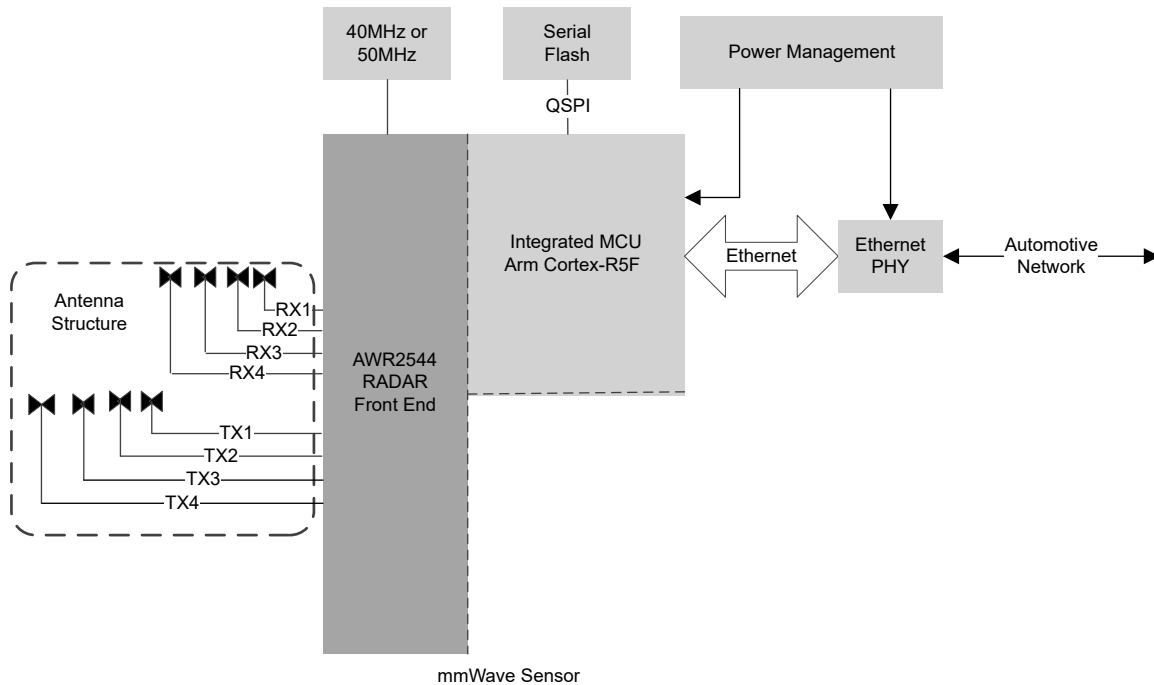

Figure 10-1. Short- and Medium-Range Radar

10.3 Reference Schematic

For reference schematics and power supply information, please contact TI Representative for access.

11 Device and Documentation Support

TI offers an extensive line of development tools. Tools and software to evaluate the performance of the device, generate code, and develop solutions are listed below.

11.1 Device Support

11.2 Device Nomenclature

To designate the stages in the product development cycle, TI assigns prefixes to the part numbers of all microprocessors (MPUs) and support tools. Each device has one of three prefixes: X, P, or null (no prefix) (for example, *XA2944PBDALT*). Texas Instruments recommends two of three possible prefix designators for its support tools: TMDX and TMDS. These prefixes represent evolutionary stages of product development from engineering prototypes (TMDX) through fully qualified production devices and tools (TMDS).

Device development evolutionary flow:

X Experimental device that is not necessarily representative of the final device's electrical specifications and may not use production assembly flow.

P Prototype device that is not necessarily the final silicon die and may not necessarily meet final electrical specifications.

null Production version of the silicon die that is fully qualified.

Support tool development evolutionary flow:

TMDX Development-support product that has not yet completed Texas Instruments internal qualification testing.

TMDS Fully-qualified development-support product.

X and P devices and TMDX development-support tools are shipped against the following disclaimer:

"Developmental product is intended for internal evaluation purposes."

Production devices and TMDS development-support tools have been characterized fully, and the quality and reliability of the device have been demonstrated fully. TI's standard warranty applies.

Predictions show that prototype devices (X or P) have a greater failure rate than the standard production devices. Texas Instruments recommends that these devices not be used in any production system because their expected end-use failure rate still is undefined. Only qualified production devices are to be used.

TI device nomenclature also includes a suffix with the device family name. This suffix indicates the package type (for example, *your package*), the temperature range (for example, blank is the default commercial temperature range), and the device speed range, in megahertz (for example, *your device speed range*). Figure x provides a legend for reading the complete device name for any *your device* device.

For orderable part numbers of *your device* devices in the *your package* package types, see the Package Option Addendum of this document, ti.com, or contact your TI sales representative.

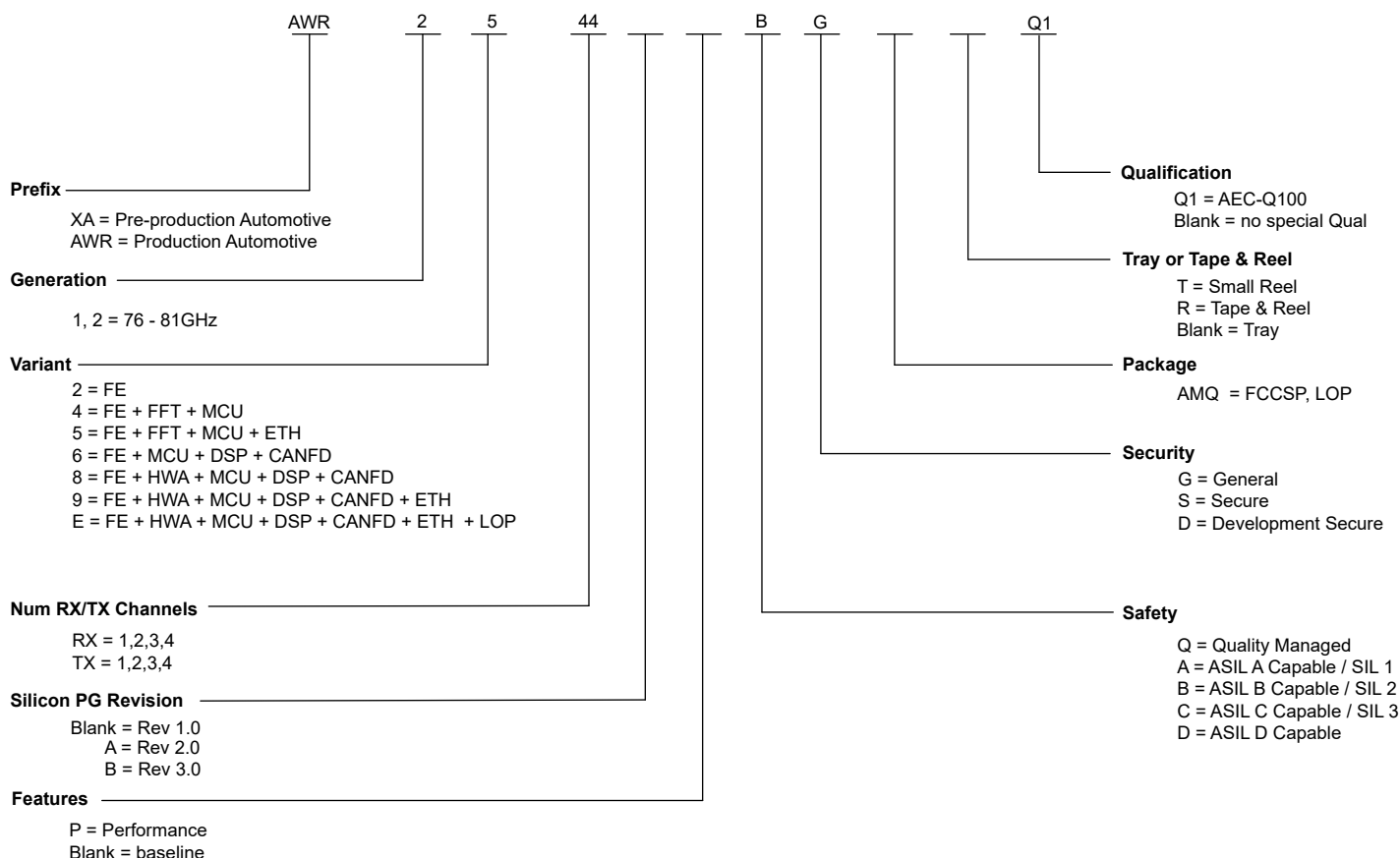
Figure 11-1. Device Nomenclature

11.3 Tools and Software

The contents in this section will be updated in subsequent versions.

11.4 Documentation support

The contents in this section will be updated in subsequent versions.

11.5 Support Resources

[TI E2E™ support forums](#) are an engineer's go-to source for fast, verified answers and design help — straight from the experts. Search existing answers or ask your own question to get the quick design help you need.

Linked content is provided "AS IS" by the respective contributors. They do not constitute TI specifications and do not necessarily reflect TI's views; see TI's [Terms of Use](#).

11.6 Trademarks

TI E2E™ is a trademark of Texas Instruments.

Arm® and Cortex-R5F® are registered trademarks of Arm Limited.

All trademarks are the property of their respective owners.

11.7 Electrostatic Discharge Caution



This integrated circuit can be damaged by ESD. Texas Instruments recommends that all integrated circuits be handled with appropriate precautions. Failure to observe proper handling and installation procedures can cause damage.

ESD damage can range from subtle performance degradation to complete device failure. Precision integrated circuits may be more susceptible to damage because very small parametric changes could cause the device not to meet its published specifications.

11.8 Glossary

[TI Glossary](#) This glossary lists and explains terms, acronyms, and definitions.

12 Revision History

Changes from November 30, 2024 to December 30, 2024 (from Revision A (November 2024) to Revision B (December 2024))

	Page
• <i>(Description)</i> : Removed x-marked OPNs from the device description table.....	2
• <i>(Signal Descriptions - Digital)</i> : Add A7 and B11 to MSS_EPWMA_SYNCO table entry.....	27
• <i>(Recommended Operating Conditions for OTP eFuse Programming)</i> : Updated with information on maximum duration of VPP supply.....	37
• <i>(Power Consumption Summary_LOP)</i> : Updated TBD values.....	39
• <i>(RF Specifications)</i> : Updated Noise Figure, In-band P1dB vs Receiver Gain.....	39
• <i>(RGMIIX and TX Timing Diagrams)</i> : Added RGMIIX and TX Timing Diagrams Section.....	54
• <i>(RGMIIX and TX Timing Diagrams)</i> : Updated table with RX and TX delay information.....	54
• <i>(RGMIIX Receive Data and Control Timing Requirements)</i> : Updated from 1ns to 1.25ns hold and setup time	55
• <i>(Device Nomenclature)</i> : Updated Device Nomenclature.....	77

Changes from January 1, 2024 to November 30, 2024 (from Revision * (January 2024) to Revision A (November 2024))

	Page
• <i>(Features)</i> : Added recommendations on power management solutions.....	1
• <i>(Description)</i> : Updated ES2.0 silicon orderable part numbers (OPNs).	2
• <i>(Description)</i> : Removed x-marked OPNs from the device description table.....	2
• <i>(Functional Block Diagram)</i> : Updated the diagram to remove a footnote.	4
• <i>(Device Comparison)</i> : Updated the table for AWR2243.	6
• <i>(Signal Descriptions - Digital)</i> : Corrected descriptions for MSS_RGMII_RDx pins.....	27
• <i>(Signal Descriptions - Digital)</i> : Added a table-note for usage of MSS_MIBSPIB signals.....	27
• <i>(Signal Descriptions - Digital)</i> : Removed pins C20 and B20 from TRACE_CLK and TRACE_CTL.....	27
• <i>(Recommended Operating Conditions)</i> : Updated MAX values for 1.2V digital and SRAM supply; and 1.8V supply.....	36
• <i>(VPP Specifications) - Warranty Impact</i> : Rephrased section.....	37
• <i>(Power Supply Specification)</i> : Added Supply Ripple specs.....	38
• <i>(Power Supply Specification)</i> : Added recommendations on power management solutions.....	38
• <i>(Power Consumption Summary)</i> : Updated the Max peak current numbers for 1.2V and 1.8V respectively from 2100mA and 600mA to 2000mA and 550mA in Table - <i>Maximum Current Ratings at Power Terminals</i> for ES2.0 silicon.....	39
• <i>(Power Consumption Summary)</i> : Updated the Description conditions and power numbers in Table - <i>Average Power Consumption at Power Terminals</i> for ES2.0 silicon.....	39
• <i>(RF Specifications)</i> : Improved Typical 1-dB compression point (Out Of Band) from -11dBm to -8dBm in ES2.0 silicon.....	39
• <i>(RF Specifications)</i> : Updated table-notes for 1-dB compression point (Out Of Band) measurement technique and a new note added for VCO2 range.....	39
• <i>(RF Specifications)</i> : Updated Noise Figure, In-band P1dB vs Receiver Gain figure in the section.....	39
• <i>(RF Specifications)</i> :Corrected IF BW to 20MHz.....	39
• <i>(Clock Specifications)</i> : Updated/Changed "Crystal Electrical Characteristics (Oscillator Mode)" to reflect correct device operating temperature range.....	43
• <i>(QSPI Timing Conditions)</i> : Updated the Output load capacitance from 2pF to 5pF.....	44
• <i>(QSPI Timing Requirements)</i> : Updated the Setup time (Q12 and Q14) from 13.2ns to 5 ns.....	44
• <i>(QSPI Switching Characteristics)</i> : Updated/Changed <i>Cycle time</i> , <i>sclk</i> from 15ns to 12.5ns;	44

- (QSPI Switching Characteristics): Updated/Changed *Pulse duration, sclk i.e. [Q2, Q3]* from $0.5 \cdot P - 1.5$ to $0.5 \cdot P - 0.625$ (Min). 44
- (QSPI Switching Characteristics): Updated/Changed *Delay time, sclk falling edge to d[0] transition i.e. [Q6, Q9]* from 5.5ns to 2ns (Max) and -2.5ns to -4.5ns (Min). 44
- (SPI Timing Conditions): Updated/Changed C_{LOAD} , *Output load capacitance* from 15pF to 20pF (Max). 46
- (SPI Controller Mode Switching Parameters, Clock Phase = 0): Updated/Changed *Cycle time, SPICLK* from 40ns to 20ns; 46
- (SPI Controller Mode Switching Parameters, Clock Phase = 0): Updated/Changed *Pulse duration, SPICLK i.e. [Q2, Q3]* from $0.5t_{c(SPC)M} + 4$ to $0.5t_{c(SPC)M} + 2$ (Min/Max). 46
- (SPI Controller Mode Switching Parameters, Clock Phase = 0): Updated/Changed *Delay time, SPISIMO valid before SPICLK low, i.e. [Q4]* from $0.5t_{c(SPC)M} - 14$ to $0.5t_{c(SPC)M} - 7$ (Min). 46
- (SPI Controller Mode Switching Parameters, Clock Phase = 0): Updated/Changed *Valid time, SPISIMO data valid after SPICLK low, i.e. [Q5]* from $0.5t_{c(SPC)M} - 18$ to $0.5t_{c(SPC)M} - 8$ (Min). 46
- (SPI Controller Mode Switching Parameters, Clock Phase = 0): Updated/Changed *Hold time, SPISOMI data valid after SPICLK i.e. [Q9]* from 3ns to 2ns (Min). 46
- (SPI Controller Mode Switching Parameters, Clock Phase = 1): Updated/Changed *Cycle time, SPICLK* from 40ns to 20ns; 49
- (SPI Controller Mode Switching Parameters, Clock Phase = 1): Updated/Changed *Pulse duration, SPICLK i.e. [Q2, Q3]* from $0.5t_{c(SPC)M} + 4$ to $0.5t_{c(SPC)M} + 2$ (Min/Max). 49
- (SPI Controller Mode Switching Parameters, Clock Phase = 1): Updated/Changed *Delay time, SPISIMO valid before SPICLK low, i.e. [Q4]* from $0.5t_{c(SPC)M} - 14$ to $0.5t_{c(SPC)M} - 7$ (Min). 49
- (SPI Controller Mode Switching Parameters, Clock Phase = 1): Updated/Changed *Valid time, SPISIMO data valid after SPICLK low, i.e. [Q5]* from $0.5t_{c(SPC)M} - 18$ to $0.5t_{c(SPC)M} - 8$ (Min). 49
- (SPI Controller Mode Switching Parameters, Clock Phase = 1): Updated/Changed *Hold time, SPISOMI data valid after SPICLK i.e. [Q9]* from 3ns to 2ns (Min). 49
- (SPI Peripheral Mode Switching Parameters): Updated/Changed *Cycle time, SPICLK* from 50ns to 20ns; 51
- (SPI Peripheral Mode Switching Parameters): Updated/Changed *Pulse duration, SPICLK i.e. [Q2, Q3]* from 20ns to 8ns (Min). 51
- (SPI Peripheral Mode Switching Parameters): Updated/Changed *Setup time, SPISIMO before SPICLK i.e. [Q6]* from 6ns to 2.1ns (Min). 51
- Updated RGMII/RMII/MII Timing Conditions..... 53
- (RGMII Receive Data and Control Timing Requirements): Updated/Changed *Hold time, i.e. [No. 6]* from 4.5ns to 1ns (Min). 55
- (RMII Transmit Data and Control Switching Characteristics): Updated/Changed *Delay time, REF_CLK high to selected transmit signals valid, i.e. [RMII 11]* from 3ns to 2ns (Min). 56
- (MII Transmit Switching Characteristics): Updated/Changed *Delay time, miin_txclk to transmit selected signals valid, i.e. [No. 1]* from 3ns to 0ns (Min). 57
- (LVDS Interface Configuration) : Corrected a typo for the number of data lanes in LVDS from '4' to '2'..... 60
- (Switching Characteristics for IEEE 1149.1 JTAG): Updated/Changed *Delay time, TCK low to TDO valid, i.e. [No. 2]* from 27.1ns to 21ns (Max). 64
- Updated BW to 20MHZ..... 68
- (ADC Channels (Service) for User Application): Added a figure in the section..... 71
- (Monitoring and Diagnostic Mechanisms): Updated the section and added a note for reference to safety related collateral. 73
- (Monitoring and Diagnostic Mechanisms): Removed CRC-8 support since polynomials are not supported in the Design..... 73
- Added package to device nomenclature..... 77

DATE	REVISION	NOTES
January 2024	*	Initial Release

13 Mechanical, Packaging, and Orderable Information

The following pages include mechanical, packaging, and orderable information. This information is the most current data available for the designated devices. This data is subject to change without notice and revision of this document. For browser-based versions of this data sheet, see the left-hand navigation.

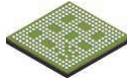

AMQ0248A

PACKAGE OUTLINE
FCCSP - 1.234 mm max height

PLASTIC BALL GRID ARRAY

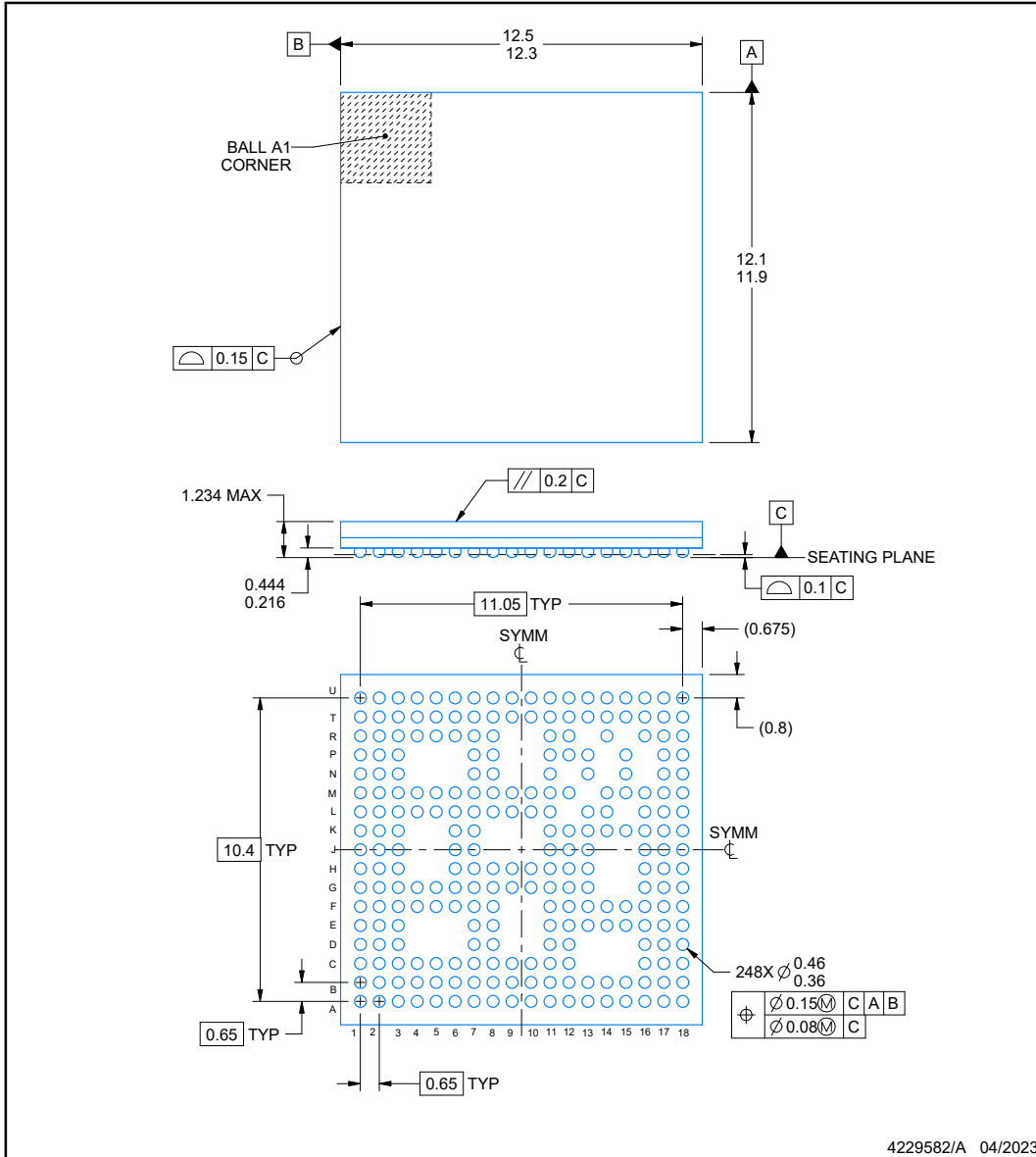

NOTES:

1. All linear dimensions are in millimeters. Any dimensions in parenthesis are for reference only. Dimensioning and tolerancing per ASME Y14.5M.
2. This drawing is subject to change without notice.

EXAMPLE BOARD LAYOUT

AMQ0248A

FCCSP - 1.234 mm max height

PLASTIC BALL GRID ARRAY

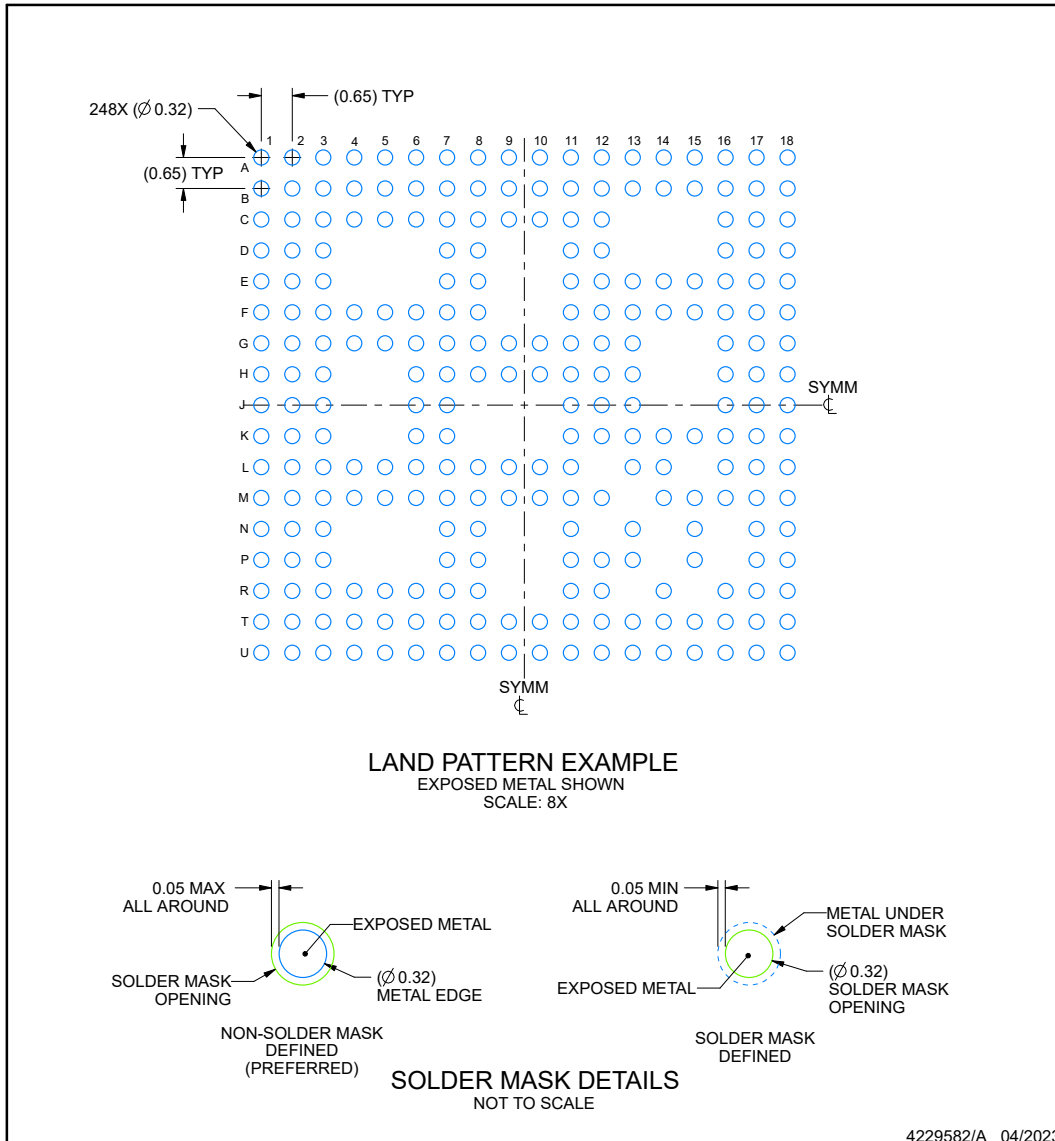

NOTES: (continued)

- Final dimensions may vary due to manufacturing tolerance considerations and also routing constraints. For information, see Texas Instruments literature number SPRAA99 (www.ti.com/lit/spraa99).

EXAMPLE STENCIL DESIGN

AMQ0248A

FCCSP - 1.234 mm max height

PLASTIC BALL GRID ARRAY

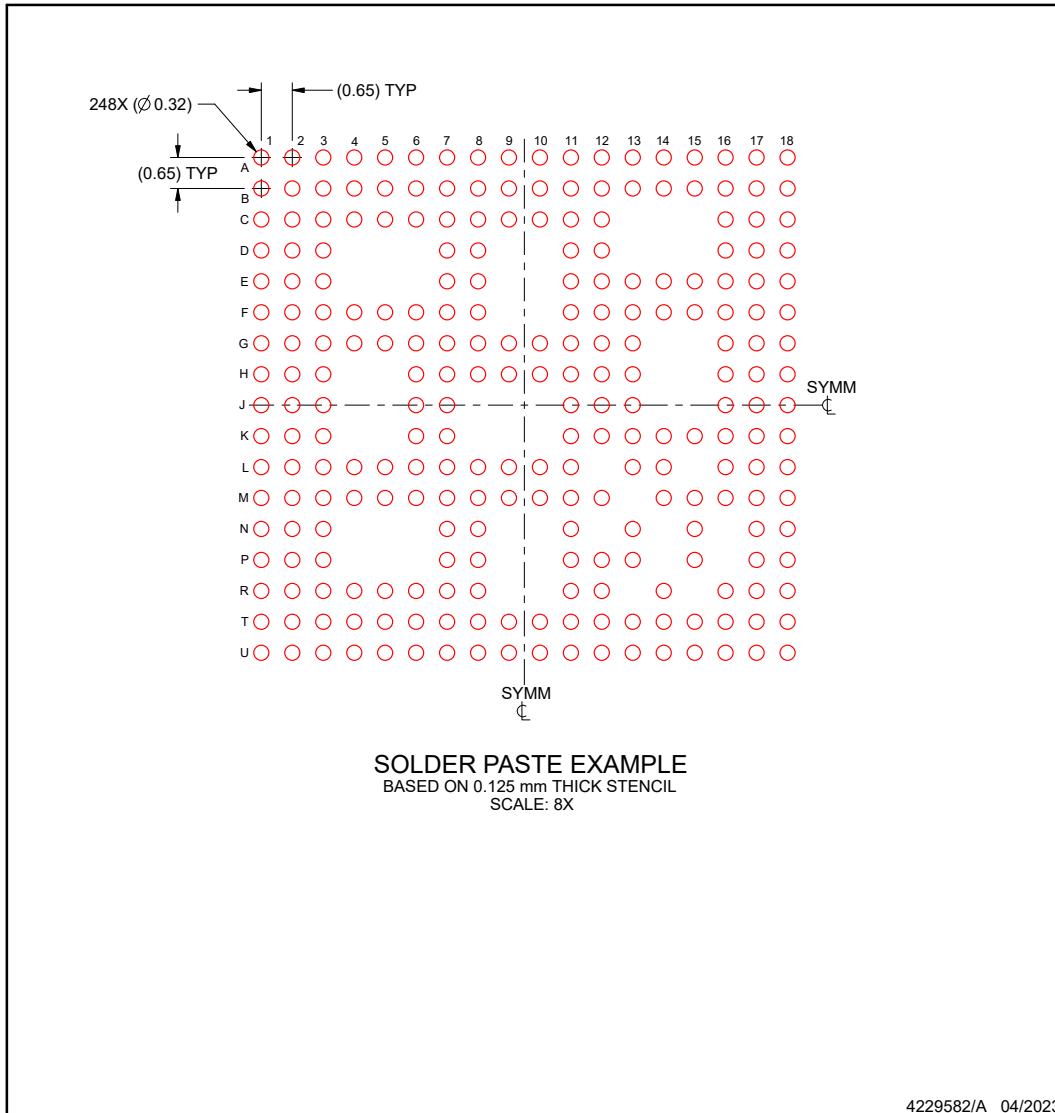

NOTES: (continued)

- 4. Laser cutting apertures with trapezoidal walls and rounded corners may offer better paste release.

PACKAGING INFORMATION

Orderable part number	Status (1)	Material type (2)	Package Pins	Package qty Carrier	RoHS (3)	Lead finish/ Ball material (4)	MSL rating/ Peak reflow (5)	Op temp (°C)	Part marking (6)
AWR2544BGAMQQ1	Active	Production	FCCSP (AMQ) 248	147 JEDEC TRAY (5+1)	Yes	Call TI	Level-3-260C-168 HR	-40 to 140	AWR2544 BG 585
AWR2544BGAMQRQ1	Active	Production	FCCSP (AMQ) 248	1000 LARGE T&R	Yes	Call TI	Level-3-260C-168 HR	-40 to 140	AWR2544 BG 585
AWR2544BGAMQRQ1.B	Active	Production	FCCSP (AMQ) 248	1000 LARGE T&R	Yes	Call TI	Level-3-260C-168 HR	-40 to 140	AWR2544 BG 585

(1) **Status:** For more details on status, see our [product life cycle](#).

(2) **Material type:** When designated, preproduction parts are prototypes/experimental devices, and are not yet approved or released for full production. Testing and final process, including without limitation quality assurance, reliability performance testing, and/or process qualification, may not yet be complete, and this item is subject to further changes or possible discontinuation. If available for ordering, purchases will be subject to an additional waiver at checkout, and are intended for early internal evaluation purposes only. These items are sold without warranties of any kind.

(3) **RoHS values:** Yes, No, RoHS Exempt. See the [TI RoHS Statement](#) for additional information and value definition.

(4) **Lead finish/Ball material:** Parts may have multiple material finish options. Finish options are separated by a vertical ruled line. Lead finish/Ball material values may wrap to two lines if the finish value exceeds the maximum column width.

(5) **MSL rating/Peak reflow:** The moisture sensitivity level ratings and peak solder (reflow) temperatures. In the event that a part has multiple moisture sensitivity ratings, only the lowest level per JEDEC standards is shown. Refer to the shipping label for the actual reflow temperature that will be used to mount the part to the printed circuit board.

(6) **Part marking:** There may be an additional marking, which relates to the logo, the lot trace code information, or the environmental category of the part.

Multiple part markings will be inside parentheses. Only one part marking contained in parentheses and separated by a "~" will appear on a part. If a line is indented then it is a continuation of the previous line and the two combined represent the entire part marking for that device.

Important Information and Disclaimer: The information provided on this page represents TI's knowledge and belief as of the date that it is provided. TI bases its knowledge and belief on information provided by third parties, and makes no representation or warranty as to the accuracy of such information. Efforts are underway to better integrate information from third parties. TI has taken and continues to take reasonable steps to provide representative and accurate information but may not have conducted destructive testing or chemical analysis on incoming materials and chemicals. TI and TI suppliers consider certain information to be proprietary, and thus CAS numbers and other limited information may not be available for release.

In no event shall TI's liability arising out of such information exceed the total purchase price of the TI part(s) at issue in this document sold by TI to Customer on an annual basis.

IMPORTANT NOTICE AND DISCLAIMER

TI PROVIDES TECHNICAL AND RELIABILITY DATA (INCLUDING DATASHEETS), DESIGN RESOURCES (INCLUDING REFERENCE DESIGNS), APPLICATION OR OTHER DESIGN ADVICE, WEB TOOLS, SAFETY INFORMATION, AND OTHER RESOURCES "AS IS" AND WITH ALL FAULTS, AND DISCLAIMS ALL WARRANTIES, EXPRESS AND IMPLIED, INCLUDING WITHOUT LIMITATION ANY IMPLIED WARRANTIES OF MERCHANTABILITY, FITNESS FOR A PARTICULAR PURPOSE OR NON-INFRINGEMENT OF THIRD PARTY INTELLECTUAL PROPERTY RIGHTS.

These resources are intended for skilled developers designing with TI products. You are solely responsible for (1) selecting the appropriate TI products for your application, (2) designing, validating and testing your application, and (3) ensuring your application meets applicable standards, and any other safety, security, regulatory or other requirements.

These resources are subject to change without notice. TI grants you permission to use these resources only for development of an application that uses the TI products described in the resource. Other reproduction and display of these resources is prohibited. No license is granted to any other TI intellectual property right or to any third party intellectual property right. TI disclaims responsibility for, and you fully indemnify TI and its representatives against any claims, damages, costs, losses, and liabilities arising out of your use of these resources.

TI's products are provided subject to [TI's Terms of Sale](#), [TI's General Quality Guidelines](#), or other applicable terms available either on [ti.com](#) or provided in conjunction with such TI products. TI's provision of these resources does not expand or otherwise alter TI's applicable warranties or warranty disclaimers for TI products. Unless TI explicitly designates a product as custom or customer-specified, TI products are standard, catalog, general purpose devices.

TI objects to and rejects any additional or different terms you may propose.

Copyright © 2025, Texas Instruments Incorporated

Last updated 10/2025

Looking for pricing, stock, or lifecycle information?

Click below to explore more details on WIN SOURCE:

 [View AWR2544BGAMQRQ1 on WIN SOURCE](#)

 [Texas Instruments](#) Information

Optimize Your Supply Chain with WIN SOURCE Solutions

-  Global Sourcing Solution
-  Obsolete Management
-  Cost Control Management
-  Shortage Management
-  Alternative Solution
-  Excess Inventory Management